



**TSU IQ Rackmount  
T1 Data Service Unit  
with  
Frame Relay Performance Monitoring**

**USER MANUAL**

**1200277L1**

**61200277L1-1B  
December 2000**

**Trademark Information**

Open View is a registered trademark of Hewlett-Packard Company.

SunNet Manager is a registered trademark of Sun Microsystems, Inc.

Netview is a registered trademark of IBM.

IQ View is a trademark of ADTRAN, Inc.

This product includes software developed by the University of California, Berkeley, and its contributors.



901 Explorer Boulevard  
P.O. Box 140000  
Huntsville, AL 35814-4000  
(256) 963-8000

© 2000 ADTRAN, Inc.  
All Rights Reserved.  
Printed in U.S.A.

The following conventions are used in this manual.



**NOTE**

*Notes provide additional useful information.*



**CAUTION**

*Cautions signify information that could prevent service interruption.*

**WARNING**

*Warnings provide information that could prevent damage to the equipment or endangerment to human life.*

**FCC regulations require that the following information be provided in this manual:**

1. This equipment complies with Part 68 of the FCC rules. On the bottom of the equipment housing is a label that shows the FCC registration number and Ringer Equivalence Number (REN) for this equipment, if applicable. If required, this information must be given to the telephone company.
2. The following information may be required when applying to the local telephone company for leased line facilities.

Service Type	REN/SOC	FIC	USOC
1.544 Mbps - SF	6.0N	04DU9-BN	RJ-48C
1.544 Mbps - SF and B8ZS	6.0N	04DU9-DN	RJ-48C
1.544 Mbps - ESF	6.0N	04DU9-1KN	RJ-48C
1.544 Mbps - ESF and B8ZS	6.0N	04DU9-1SN	RJ-48C
PRI ISDN	6.0N	04DU9-1SN	FJ-48C

3. An FCC compliant telephone cord with a modular plug may be provided with this equipment. This equipment is designed to be connected to the telephone network or premises wiring using a compatible modular jack, which is FCC Part 68 compliant. See installation instructions for details.
4. If this equipment causes harm to the telephone network, the telephone company may temporarily discontinue service. If possible, advance notification is given; otherwise, notification is given as soon as possible. The telephone company will advise the customer of the right to file a complaint with the FCC.
5. The telephone company may make changes in its facilities, equipment, operations, or procedures that could affect the proper operation of this equipment. If this happens, the telephone company will provide advance notification and the opportunity to make the necessary modifications to maintain uninterrupted service.
6. If experiencing difficulty with this equipment, please contact ADTRAN for repair and warranty information. If the equipment is causing harm to the network, the telephone company may request this equipment to be disconnected from the network until the problem is resolved or it is certain that the equipment is not malfunctioning.
7. This unit contains no user serviceable parts.
8. The FCC recommends that the AC outlet, to which equipment requiring AC power is to be installed, is provided with an AC surge arrester.

**Affidavit for Connection of Customer Premises Equipment to  
1.544 MBPS and/or Subrate Digital Services**

For the work to be performed in the certified territory of \_\_\_\_\_ (telco name)

State of \_\_\_\_\_

County of \_\_\_\_\_

I, \_\_\_\_\_ (name), \_\_\_\_\_ (business address),  
\_\_\_\_\_ (telephone number) being duly sworn, state:

I have the responsibility for the operation and maintenance of the terminal equipment to be connected to 1.544 Mbps and/or \_\_\_\_\_ subrate digital services. The terminal equipment to be connected complies with Part 68 of the FCC rules except for the encoded analog content and billing protection specification.

With respect to encoded analog content and billing protection:

I attest that all operations associated with the establishment, maintenance and adjustment of the digital CPE with respect to encoded analog content and billing protection information continuously complies with Part 68 of the FCC rules and Regulations.

The digital CPE does not transmit digital signals containing encoded analog content or billing information which is intended to be decoded within the telecommunications network.

The encoded analog content and billing protection is factory set and is not under the control of the customer.

I attest that the operator(s) maintainer(s) of the digital CPE responsible for the establishment, maintenance and adjustment of the encoded analog content and billing information has (have) been trained to perform these functions by successfully having completed one of the following (check appropriate blocks):

A. A training course provided by the manufacturer/grantee of the equipment used to encode analog signals; or

B. A training course provided by the customer or authorized representative, using training materials and instructions provided by the manufacturer/

grantee of the equipment used to encode analog signals; or

( ) C. An independent training course (e.g., trade school or technical institution) recognized by the manufacturer/grantee of the equipment used to encode analog signals; or

( ) D. In lieu of the preceding training requirements, the operator(s)/maintainer(S) is (are) under the control of a supervisor trained in accordance with \_\_\_\_\_ (circle one) above.

I agree to provide \_\_\_\_\_ (telco's name) with proper documentation to demonstrate compliance with the information in the preceding paragraph, if so requested.

\_\_\_\_\_ Signature

\_\_\_\_\_ Title

\_\_\_\_\_ Date

Subscribed and sworn to before me

This \_\_\_\_\_ day of \_\_\_\_\_, 20\_\_

\_\_\_\_\_  
Notary Public

My commission expires: \_\_\_\_\_

## **Affidavit Requirements for Connection to Digital Services**

- An affidavit is required to be given to the telephone company whenever digital terminal equipment without encoded analog content and billing protection is used to transmit digital signals containing encoded analog content which are intended for eventual conversion into voice band analog signal and transmitted on the network.
- The affidavit shall affirm that either no encoded analog content or billing information is being transmitted or that the output of the device meets Part 68 encoded analog content or billing protection specification.
- End use/customer will be responsible to file an affidavit with the local exchange carrier when connecting unprotected CPE to a 1.544 Mbps or sub-rate digital service.
- Until such time as subrate digital terminal equipment is registered for voice applications, the affidavit requirements for subrate services are waived.

## FEDERAL COMMUNICATIONS COMMISSION RADIO FREQUENCY INTERFERENCE STATEMENT

This equipment has been tested and found to comply with the limits for a Class A digital device, pursuant to Part 15 of the FCC Rules. These limits are designed to provide reasonable protection against harmful interference when the equipment is operated in a commercial environment. This equipment generates, uses, and can radiate radio frequency energy and, if not installed and used in accordance with the instruction manual, may cause harmful interference to radio frequencies. Operation of this equipment in a residential area is likely to cause harmful interference in which case the user will be required to correct the interference at his own expense.

Shielded cables must be used with this unit to ensure compliance with Class A FCC limits.

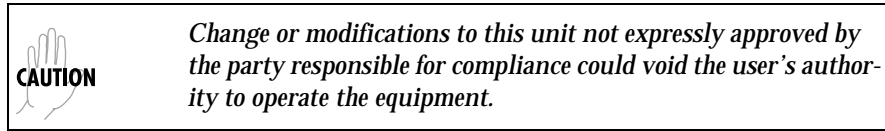

## CANADIAN EMISSIONS REQUIREMENTS

This digital apparatus does not exceed the Class A limits for radio noise emissions from digital apparatus as set out in the interference-causing equipment standard entitled "Digital Apparatus," ICES-003 of the Department of Communications.

Cet appareil numérique respecte les limites de bruits radioélectriques applicables aux appareils numériques de Class A prescrites dans la norme sur le matériel brouilleur: "Appareils Numériques," NMB-003 édictée par le ministre des Communications.



## CANADIAN EQUIPMENT LIMITATIONS

Notice: The Canadian Industry and Science Canada label identifies certified equipment. This certification means that the equipment meets certain telecommunications network protective, operational, and safety requirements. The Department does not guarantee the equipment will operate to the user's satisfaction.

Before installing this equipment, users should ensure that it is permissible to be connected to the facilities of the local telecommunications company. The equipment must also be installed using an acceptable methods of connection. In some cases, the company's inside wiring associated with a single line individual service may be extended by means of a certified connector assembly (telephone extension cord). The customer should be aware that compliance with the above limitations may not prevent degradation of service in some situations.

Repairs to certified equipment should be made by an authorized Canadian maintenance facility designated by the supplier. Any repairs or alterations made by the user to this equipment, or equipment malfunctions, may give the telecommunications company cause to request the user to disconnect the equipment.

Users should ensure for their own protection that the electrical ground connections of the power utility, telephone lines and internal metallic water pipe system, if present, are connected together. This precaution may be particularly important in rural areas.

### **WARNING**

*Users should not attempt to make such connections themselves, but should contract the appropriate electric inspection authority, or an electrician, as appropriate.*

The Load Number (LN) assigned to each terminal device denotes the percentage of the total load to be connected to a telephone loop which is used by the device, to prevent overloading. The termination on a loop may consist of any combination of devices subject only to the requirement that the total of the Load Numbers of all devices does not exceed 100.

## **IMPORTANT SAFETY INFORMATION**

### **SAVE THESE INSTRUCTIONS**

**When using your telephone equipment, please follow these basic safety precautions to reduce the risk of fire, electrical shock, or personal injury:**

1. Do not use this product near water, such as near a bathtub, wash bowl, kitchen sink, laundry tub, in a wet basement, or near a swimming pool.
2. Avoid using a telephone (other than a cordless-type) during an electrical storm. There is a remote risk of shock from lightning.
3. Do not use the telephone to report a gas leak in the vicinity of the leak.
4. Use only the power cord, power supply, and/or batteries indicated in the manual. Do not dispose of batteries in a fire. They may explode. Check with local codes for special disposal instructions.

## **WARRANTY AND CUSTOMER SERVICE**

ADTRAN will replace or repair this product within five years from the date of shipment if it does not meet its published specifications or fails while in service. For detailed warranty, repair, and return information refer to the ADTRAN Equipment Warranty and Repair and Return Policy Procedure.

Return Material Authorization (RMA) is required prior to returning equipment to ADTRAN.

For service, RMA requests, or further information, contact one of the numbers listed on the back page of this manual.

## LIMITED PRODUCT WARRANTY

ADTRAN warrants that for five (5) years from the date of shipment to Customer, all products manufactured by ADTRAN will be free from defects in materials and workmanship. ADTRAN also warrants that products will conform to the applicable specifications and drawings for such products, as contained in the Product Manual or in ADTRAN's internal specifications and drawings for such products (which may or may not be reflected in the Product Manual). This warranty only applies if Customer gives ADTRAN written notice of defects during the warranty period. Upon such notice, ADTRAN will, at its option, either repair or replace the defective item. If ADTRAN is unable, in a reasonable time, to repair or replace any equipment to a condition as warranted, Customer is entitled to a full refund of the purchase price upon return of the equipment to ADTRAN. This warranty applies only to the original purchaser and is not transferable without ADTRAN's express written permission. This warranty becomes null and void if Customer modifies or alters the equipment in any way, other than as specifically authorized by ADTRAN.

EXCEPT FOR THE LIMITED WARRANTY DESCRIBED ABOVE, THE FOREGOING CONSTITUTES THE SOLE AND EXCLUSIVE REMEDY OF THE CUSTOMER AND THE EXCLUSIVE LIABILITY OF ADTRAN AND IS IN LIEU OF ANY AND ALL OTHER WARRANTIES (EXPRESSED OR IMPLIED). ADTRAN SPECIFICALLY DISCLAIMS ALL OTHER WARRANTIES, INCLUDING (WITHOUT LIMITATION), ALL WARRANTIES OF MERCHANTABILITY AND FITNESS FOR A PARTICULAR PURPOSE. SOME STATES DO NOT ALLOW THE EXCLUSION OF IMPLIED WARRANTIES, SO THIS EXCLUSION MAY NOT APPLY TO CUSTOMER.

In no event will ADTRAN or its suppliers be liable to Customer for any incidental, special, punitive, exemplary or consequential damages experienced by either Customer or a third party (including, but not limited to, loss of data or information, loss of profits, or loss of use). ADTRAN is not liable for damages for any cause whatsoever (whether based in contract, tort, or otherwise) in excess of the amount paid for the item. Some states do not allow the limitation or exclusion of liability for incidental or consequential damages, so the above limitation or exclusion may not apply to Customer.



# Table of Contents

---

<b>List of Figures .....</b>	<b>xxv</b>
<b>List of Tables .....</b>	<b>xxvii</b>
<b>Chapter 1. Introduction .....</b>	<b>1-1</b>
Product overview .....	1-1
Features .....	1-2
Understanding Frame Relay .....	1-3
T1/FT1 Overview .....	1-4
T1 Service Offerings.....	1-4
Fractional T1.....	1-5
SNMP Management .....	1-5
Network Manager .....	1-5
Agent .....	1-6
MIB .....	1-6
TELNET .....	1-6
Dial Backup Operation .....	1-6
Interface Card Options .....	1-7
DCE DBU Plug-On Card.....	1-7
PRI DBU Plug-On Card.....	1-7
<b>Chapter 2. Installation .....</b>	<b>2-1</b>
Unpack, Inspect, Power Up .....	2-1
Receipt Inspection.....	2-1
ADTRAN Shipments Include.....	2-1
Customer Provides.....	2-2
Rear Interface Card .....	2-2
Test Jacks .....	2-4
Monitor .....	2-4
In/Out .....	2-4
Network Connector: Network Interface Connection.....	2-4
PRI DBU Interface .....	2-4
V.35 Connector: DTE Data Connection.....	2-5
DTE DBU Interface.....	2-5
LAN Interface .....	2-5

Power Up and Initialization .....	2-5
<b>Chapter 3. Operation.....</b>	<b>3-1</b>
Front Panel .....	3-1
Control Port.....	3-2
LED Descriptions.....	3-2
RS: Request to Send .....	3-2
CS: Clear to Send .....	3-2
TD: Transmit Data .....	3-2
RD: Receive Data .....	3-2
ERR: Error .....	3-2
ALM: Alarm .....	3-3
TST: Test .....	3-3
DBU: Dial Backup .....	3-3
Smart 16/Smart 16e Controller Card .....	3-3
Menu definitions for Smart16 Controller Access.....	3-5
IP Address .....	3-5
Control Port.....	3-5
Port Mode .....	3-5
Baud Rate .....	3-5
Factory Restore .....	3-5
VT-100 Terminal Connection and Operation .....	3-6
TSU IQ Rackmount Menu Structure .....	3-8
Main Menu .....	3-8
Configuration .....	3-8
View Statistics .....	3-8
Test .....	3-8
Dial .....	3-8
Logout .....	3-8
<b>Chapter 4. Applications.....</b>	<b>4-1</b>
Management Applications .....	4-1
Local VT-100 Terminal Management .....	4-1
Minimum Configuration Requirements for VT-100 Management .....	4-2
Control Port Mode .....	4-2
Baud Rate .....	4-2
Out-of-Band Management .....	4-3
Minimum Configuration Requirements for SNMP or Telnet Access .....	4-4
Control Port Mode .....	4-4
IP Address .....	4-4
Subnet Mask .....	4-4
Gateway IP Address (if required) .....	4-4

Read Community Name .....	4-4
Write Community Name .....	4-4
Trap Manager DLCI .....	4-5
Trap Manager IP Address .....	4-5
Trap Manager Port .....	4-5
In-Band Management .....	4-5
Local PVC Management .....	4-6
Configuration Requirements for Local PVC Management .....	4-7
IP Address .....	4-7
Management DLCI .....	4-7
Read Community Name .....	4-7
Write Community Name .....	4-7
Trap Manager DLCI .....	4-7
Trap Manager IP Address .....	4-7
Trap Manager Port .....	4-8
Shared PVC Management .....	4-8
Configuration Requirements for Shared PVC Management .....	4-9
IP Address .....	4-9
Management DLCI 1 and/or DLCI 2 .....	4-9
Management DLCI 1 and/or DLCI 2 Mode .....	4-9
Read Community Name .....	4-9
Write Community Name .....	4-9
Trap Manager DLCI .....	4-10
Trap Manager IP Address .....	4-10
Trap Manager Port .....	4-10
Dedicated PVC Management .....	4-10
Configuration Requirements for Dedicated PVC Management .....	4-11
Dial Backup Application .....	4-11
DBU Application 1 (non-PRI) .....	4-13
DBU Application 2 (PRI) .....	4-15
<b>Chapter 5. Configuration Overview .....</b>	<b>5-1</b>
Local and Remote Configuration .....	5-1
<b>Chapter 6. DTE Port Configuration .....</b>	<b>6-1</b>
Physical Layer Options.....	6-2
Flow Control .....	6-2
None .....	6-2
Hardware .....	6-3
FECN/BECN .....	6-3
CTS Option .....	6-3
Forced On .....	6-3

Table of Contents

---

Follow RTS .....	6-3
DSR Option .....	6-3
Forced On .....	6-3
Normal .....	6-3
CD Option .....	6-3
Forced On .....	6-3
Normal .....	6-4
TC Clock Option .....	6-4
Normal .....	6-4
Inverted .....	6-4
Frame Relay Options .....	6-4
T391 .....	6-4
N392 and N393 .....	6-4
Management DLCI .....	6-5
Guidelines for Configuring Management DLCI .....	6-5
Management PVC Option .....	6-5
Signaling Responses .....	6-5
Always On .....	6-5
Follow Network .....	6-6
Always Off .....	6-6
<b>Chapter 7. Network Port Configuration.....</b>	<b>7-1</b>
Network port .....	7-1
Physical Layer Options.....	7-2
Framing Format .....	7-2
Line Code .....	7-2
Clock Source .....	7-2
Line Buildout .....	7-2
Rx Sensitivity .....	7-2
Channel Bandwidth .....	7-2
Channel Alignment .....	7-3
Start Channel .....	7-3
Number of Channels .....	7-3
Transmit PRM .....	7-3
Frame Relay Options .....	7-4
Signaling Type .....	7-4
T391 .....	7-4
N391 .....	7-4
N392 and N393 .....	7-5
Management DLCI 1 and 2 .....	7-5
Management DLCI 1 and 2 Mode.....	7-5
Maximum PVC Count .....	7-6



History Interval Count .....	7-6
PVC Options .....	7-6
DLCI .....	7-6
DBU DLCI .....	7-6
DBU Phone Number .....	7-7
DBU on Inactive .....	7-7
DBU Call Order # .....	7-7
CIR (Kbps) .....	7-8
Seq Num Checking .....	7-8
PVC Delay .....	7-8
Stats Option .....	7-8
Auto .....	7-8
Enabled .....	7-9
Disabled .....	7-9
Next .....	7-9
Previous .....	7-9
Add .....	7-9
Delete .....	7-9
<b>Chapter 8. Dial Backup Options.....</b>	<b>8-1</b>
Dial Backup Options .....	8-1
Auto DBU .....	8-3
DBU Options.....	8-3
Answer/Originate .....	8-3
Daily Lockout .....	8-3
Lockout Start .....	8-3
Lockout End .....	8-3
Weekend Lock .....	8-3
DBU Criteria .....	8-4
With Network Failure .....	8-4
With No LMI .....	8-4
With PVC Inactive .....	8-4
DBU Timers.....	8-4
Fail Timer .....	8-4
Restore Timer .....	8-4
Redial Counter .....	8-4
Wait to Redial .....	8-5
DBU Card Configuration Options.....	8-5
PRI Options .....	8-5
Physical Layer Options .....	8-5
Switch Types .....	8-7
LDN .....	8-7

Table of Contents

---

DCE Options .....	8-7
Interface Type .....	8-7
DBU Bit Rate .....	8-7
<b>Chapter 9. System Configuration .....</b>	<b>9-1</b>
Change Password.....	9-1
Ethernet Port .....	9-1
IP Address .....	9-1
Subnet Mask.....	9-1
IP Address .....	9-2
Control Port Mode .....	9-2
Read Community Name.....	9-2
Write Community Name.....	9-3
Trap Mgr Options.....	9-3
Trap Manager DLCI .....	9-3
Trap Manager IP Address .....	9-3
Trap Manager Port .....	9-3
Next .....	9-3
Previous .....	9-3
Add .....	9-3
Delete .....	9-3
Protocols 1 and 2.....	9-4
None .....	9-4
IP .....	9-4
IPX .....	9-4
ARP .....	9-4
SNA .....	9-4
Unknown .....	9-4
System Name .....	9-5
System Time/Date .....	9-5
History Interval Size .....	9-5
<b>Chapter 10. Statistics.....</b>	<b>10-1</b>
Viewing Statistical Information .....	10-1
Statistics Display Options .....	10-2
View by Interval .....	10-2
View by Day .....	10-2
Hot Keys .....	10-3
ESC=Menu .....	10-3
D=DLCI .....	10-3
Page (+, -) .....	10-3
Scroll (<, >) .....	10-3

---

DTE Port Statistics.....	10-4
Leads On .....	10-4
Interval Remaining .....	10-5
Signaling State .....	10-5
Local PVC Rx Frames .....	10-5
Local PVC Rx Bytes .....	10-5
Local PVC Tx Frames .....	10-5
Local PVC Tx Bytes .....	10-6
Signal Down Time .....	10-6
Signal Error .....	10-6
Signal Timeouts .....	10-6
Signal State Change .....	10-6
Rx Full Status .....	10-6
Rx LI Only .....	10-6
Discard Frame .....	10-6
Aborts .....	10-6
CRC Errors .....	10-7
Octet Align .....	10-7
Length Error .....	10-7
EA Violation .....	10-7
Encapsulation Error .....	10-7
Inactive DLCI .....	10-7
Invalid DLCI .....	10-7
Unrouteable .....	10-7
Network Port Statistics.....	10-8
Signaling State .....	10-9
Interval Remaining .....	10-9
TSU State .....	10-9
PRI State .....	10-9
DBU State .....	10-9
Rx Frames .....	10-9
Rx Bytes .....	10-9
Maximum Rx Throughput .....	10-10
Average Rx Throughput .....	10-10
Maximum Rx Utilization .....	10-10
Average Rx Utilization .....	10-10
Tx Frames .....	10-10
Tx Bytes .....	10-10
Maximum Tx Throughput .....	10-10
Average Tx Throughput .....	10-10
Maximum Tx Utilization .....	10-10
Average Tx Utilization .....	10-10

Table of Contents

---

Port UA Time .....	10-11
Signal Down Time .....	10-11
Signal Error .....	10-11
Signal Timeouts .....	10-11
Signal State Change .....	10-11
Rx Full Status .....	10-11
Tx Full Status .....	10-11
Rx LI Only .....	10-11
Tx LI Only .....	10-11
Async Status .....	10-11
Discard Frame .....	10-11
Aborts .....	10-12
CRC Errors .....	10-12
Octet Align .....	10-12
T1 State Change .....	10-12
T1 UA Time .....	10-12
Signal Loss .....	10-12
Telco Test .....	10-12
AIS Alarm .....	10-13
Red Alarm .....	10-13
Yellow Alarm .....	10-13
PLL Alarm .....	10-13
Path Code .....	10-13
Line Code .....	10-13
Length Error .....	10-13
EA Violation .....	10-13
Encapsulation Error .....	10-13
Inactive DLCI .....	10-14
Invalid DLCI .....	10-14
Unrouteable .....	10-14
Layer 3 Statistics .....	10-14
Px Type (current) .....	10-15
Interval Remaining .....	10-16
Px Type (listed for each interval) .....	10-16
Px Rx Frames .....	10-16
Px Rx Bytes .....	10-16
Px Rx Dist% .....	10-17
Px Tx Frames .....	10-17
Px Tx Bytes .....	10-17
Px Tx Dist% .....	10-17
Top Talkers.....	10-17
Address Type .....	10-18

---

Interval Remaining .....	10-18
Rx Distribution .....	10-18
Tx Distribution .....	10-18
DBU Port Statistics .....	10-19
PRI Channels .....	10-20
PRI State .....	10-20
DS0 Status .....	10-20
DBU State .....	10-20
Interval Remaining .....	10-21
Rx Frames .....	10-21
Rx Bytes .....	10-21
Maximum Rx Throughput .....	10-21
Average Rx Throughput .....	10-21
Maximum Rx Utilization .....	10-21
Average Rx Utilization .....	10-21
Tx Frames .....	10-21
Tx Bytes .....	10-21
Maximum Tx Throughput .....	10-21
Average Tx Throughput .....	10-21
Maximum Tx Utilization .....	10-22
Average Tx Utilization .....	10-22
Time in DBU .....	10-22
Discard Frame .....	10-22
Aborts .....	10-22
CRC Errors .....	10-22
Octet Align .....	10-22
T1 State Change .....	10-22
T1 UA Time .....	10-22
Length Error .....	10-23
Encapsulation Error .....	10-23
Unrouteable .....	10-23
Call Manager .....	10-24
DLCI Statistics .....	10-25
DLCI Statistics for a Specific DLCI .....	10-25
Throughput (Tx and Rx) .....	10-25
Utilization .....	10-25
Remaining .....	10-25
Rx Frames .....	10-26
Rx Bytes .....	10-26
Maximum Rx Throughput .....	10-26
Average Rx Throughput .....	10-26
Maximum Rx Utilization .....	10-26

Table of Contents

---

Average Rx Utilization .....	10-26
Tx Frames .....	10-26
Tx Bytes .....	10-26
Maximum Tx Throughput .....	10-26
Average Tx Throughput .....	10-26
Maximum Tx Utilization .....	10-27
Average Tx Utilization .....	10-27
Time in DBU .....	10-27
PVC IA Time .....	10-27
Rx FECN .....	10-27
Tx FECN .....	10-27
Rx BECN .....	10-27
Tx BECN .....	10-27
Rx DE .....	10-27
Tx DE .....	10-28
Rx CR .....	10-28
Tx CR .....	10-28
Lost Frames .....	10-28
Remote Lost Frames .....	10-28
Rx Burst Seconds .....	10-28
Tx Burst Seconds .....	10-28
Minimum Rx Frame .....	10-28
Maximum Rx Frame .....	10-28
Average Rx Frame .....	10-29
Minimum Tx Frame .....	10-29
Maximum Tx Frame .....	10-29
Average Tx Frame .....	10-29
Minimum Frame Delay .....	10-29
Maximum Frame Delay .....	10-29
Average Frame Delay .....	10-29
PVC State Change .....	10-29
DLCI List.....	10-30
System Statistics.....	10-31
<b>Chapter 11. Testing.....</b>	<b>11-1</b>
Ping.....	11-1
Address to Ping .....	11-1
Start Ping .....	11-2
Pings Transmitted .....	11-2
Ping Responses .....	11-2
Min Response Time .....	11-2
Max Response Time .....	11-2

---

Avg Response Time .....	11-2
PVC Loopback .....	11-2
Enter DLCI or 0 for All (DLCI) .....	11-3
Test Length .....	11-3
Start Test .....	11-3
Stop Test .....	11-3
View Test .....	11-4
PVC Active/Inactive/Undefined .....	11-4
Test Active/No Test Active .....	11-4
Frames Rx .....	11-4
Frames Tx .....	11-4
Lost Frames .....	11-4
Remote Lost Frames .....	11-4
Minimum Loop Response Time .....	11-4
Maximum Loop Response Time .....	11-5
Average Loop Response Time .....	11-5
Reset Test Stats .....	11-5
View DLCI List .....	11-5
<b>Chapter 12. Activating Dialing Functions .....</b>	<b>12-1</b>
Dialing Options .....	12-1
Dial Options when Dial Backup is Idle.....	12-2
Dial Backup .....	12-2
Stay on Leased .....	12-2
Dial Options During Dial Backup.....	12-2
Hang Up .....	12-2
Stay On Line .....	12-2
<b>Appendix A. Pinouts.....</b>	<b>A-1</b>
<b>Appendix B. Specifications Summary .....</b>	<b>B-1</b>
<b>Appendix C. Acronyms and Abbreviations .....</b>	<b>C-1</b>
<b>Appendix D. Glossary .....</b>	<b>D-1</b>
<b>Index .....</b>	<b>Index-1</b>

Table of Contents

---



# List of Figures

---

Figure 2-1. TSU IQ Rackmount Rear View .....	2-3
Figure 2-2. Power Up Test Sequence.....	2-6
Figure 3-1. TSU IQ Rackmount Faceplate.....	3-1
Figure 3-2. Menu Structure for Access via the Smart16 Controller.....	3-4
Figure 3-3. Terminal Login Menu.....	3-6
Figure 3-4. Terminal Main Menu.....	3-7
Figure 4-1. VT-100 Management Application Example .....	4-2
Figure 4-2. Out-of-Band Management Application.....	4-3
Figure 4-3. Local PVC Management Application .....	4-6
Figure 4-4. Shared PVC Management Application .....	4-8
Figure 4-5. Dedicated PVC Management Application.....	4-10
Figure 4-6. Dial Backup Application (non-PRI) .....	4-13
Figure 4-7. PRI DBU Card at Host Site (A) .....	4-15
Figure 5-1. Configuration Menu Tree .....	5-2
Figure 6-1. DTE Port Configuration Menu .....	6-1
Figure 6-2. DTE Port Menu Tree .....	6-2
Figure 7-1. Network Port Configuration Menu .....	7-1
Figure 7-2. Network Port Frame Relay Options Menu .....	7-4
Figure 8-1. DBU Options Menu (DTE DBU Card Installed) .....	8-1
Figure 8-2. Dial Backup Menu Tree.....	8-2
Figure 9-1. System Configuration Menu .....	9-2
Figure 10-1. View Statistics Menu .....	10-1
Figure 10-2. DTE Port Statistics (View by Day).....	10-4
Figure 10-3. DTE Port Statistics (View by Interval) .....	10-5
Figure 10-4. Network Port Statistics (DBU Card Installed) .....	10-8
Figure 10-5. Network Port Statistics (View by Day).....	10-8
Figure 10-6. Top Talkers Menu.....	10-18
Figure 10-7. DBU Port Statistics (View by Interval) .....	10-19
Figure 10-8. DBU Port Statistics (View by Day) .....	10-19
Figure 10-9. Call Manager .....	10-24
Figure 10-10. DLCI Statistics for a Specific DLCI (View by Day) .....	10-25

List of Figures

---

Figure 10-11. DLCI Statistics Summary for All Available DLCIs .....	10-30
Figure 10-12. System Statistics Screen.....	10-31
Figure 11-1. Test Menu .....	11-1
Figure 11-2. PVC Loopback Menu.....	11-3
Figure 11-3. Test Status Screen .....	11-5
Figure 12-1. Dial Options Menu (non-PRI DBU) .....	12-1
Figure 12-2. Dial Options Menu (PRI DBU) .....	12-1

# List of Tables

---

Table 4-1. Example Settings for DBU Options .....	4-14
Table 4-2. Example Settings for PVC Configuration Table .....	4-14
Table 4-3. Example Settings for PRI DBU Card (A) .....	4-16
Table 4-4. Global DBU Settings (B and C).....	4-16
Table 4-5. Example Settings for PRI DBU Card at Host Site .....	4-16
Table 10-1. Possible TSU States .....	10-9
Table 10-2. PRI Channel Descriptions .....	10-20
Table 10-3. Possible PRI States.....	10-20
Table 10-4. PRI Channels and Their Status.....	10-24
Table A-1. Pin Assignments for Network Connector .....	A-1
Table A-2. Pin Assignments for PRI DBU Connector .....	A-1
Table A-3. Pin Assignments for V.35 Connector .....	A-2
Table A-4. Pin Assignments for Control Connector.....	A-3
Table A-5. Pin Assignments for 10BaseT Connector (Ethernet Card) .....	A-3
Table A-6. Pin Assignments DTE DBU Connector.....	A-4

List of Tables

---

## Chapter 1 Introduction

---

### PRODUCT OVERVIEW

The ADTRAN TSU IQ Rackmount provides the visibility and control needed for both the physical and logical connections made in frame relay networks. The TSU IQ Rackmount provides logical layer monitoring and management for frame relay. Each permanent virtual circuit (PVC) accessed through a TSU IQ Rackmount is managed end-to-end as if it were a leased-line connection. Real-time statistics on throughput, bandwidth utilization, availability, bursting, congestion, and network delay are collected and stored in the Frame IQ MIB (management information base). This information can then be gathered by management systems and used to monitor network health and perform long-term network planning.

The unit's embedded SNMP (simple network management protocol) agent provides complete SNMP access to the unit. SNMP access is available through the DTE or network port or through an integral SLIP (serial line internet protocol) or PPP (point-to-point protocol) async port. 10BaseT ethernet access is also provided for SNMP.

## FEATURES

The following are features of the TSU IQ Rackmount:

- Complete and comprehensive frame relay monitoring.
- Real-time measurement of bandwidth utilization, committed information rates (CIRs), and excess burst rates on each PVC.
- True non-intrusive, in-band transmission of statistics.
- Embedded SNMP and TELNET through the DTE, network, or SLIP/PPP port, or through the ethernet interface.
- Control port provides SLIP and async PPP access to SNMP or VT-100 terminal configuration.
- Dial backup (DBU) available with optional plug-on modules.
- End-to-end network round trip delay measurements for network optimization.
- Frame IQ MIB is standard ANSI format compatible with popular enterprise reporting systems.
- Standard DTE (data terminal equipment) interfaces.

The PRI DBU card allows the TSU IQ RM to accept or place up to 23 dial backup calls simultaneously.

The TSU IQ Rackmount provides a V.35 electrical and physical DTE interface to accommodate a variety of applications.

## UNDERSTANDING FRAME RELAY

Frame relay is a wide area network (WAN) service designed to minimize physical connections. This is accomplished by using virtual connections within the frame relay cloud and accessing these virtual circuits with normally one physical connection at each location to the frame relay service. Virtual circuits are addressed using header information at the beginning of each frame. These frames are formatted by the Enterprise Networking users (END) such as the ADTRAN TSU IQ Rackmount.

ANSI (American National Standards Institute) standards describe how each frame must be constructed to provide interoperability between END equipment and frame relay switching equipment. Each frame must contain a header, at least one byte of information data, two bytes of CRC16, and a trailing flag 0x7E.

This header information contains a virtual circuit address known as a DLCI (data link connection identifier). The header information also contains bits used for network congestion control.

Frame relay virtual circuits may be defined as permanent (PVC) or switched (SVC). PVCs have the same DLCI for a given path each time a user protocol session is established. The network service provider assigns these DLCIs at subscription time. SVCs, on the other hand, have DLCIs dynamically assigned each time a user protocol session is established. The END equipment must request a call and the DLCI is assigned by the network switching equipment. This DLCI is valid until the call is disconnected and may be assigned a different value each time a call is requested.

## T1/FT1 OVERVIEW

The telephone companies (telcos) have used T1 digital communications links for voice transmission since the early sixties. The D4 channel bank is an example of a T1 digital carrier system that was introduced in the mid-seventies and is still widely used by the telcos. Communication demands of businesses continued to grow to the point that the telcos began offering T1 service directly to the public. D4 channel banks began to be used for T1 in corporate network topographies for voice. The technological advances in computer development also created a demand for T1 data communication, which now is a large part of the T1 traffic.

## T1 Service Offerings

T1 is a digital service that the service providers deliver to the user over two pairs of wires. The signal operates at 1.544 Mbps and is usually extended by repeaters installed about every mile after the first 6000 feet. The T1 signal is divided into 24 time slots or digital signal level zeros (DS0s) which operate at 64 kbps. Each time slot is occupied by digitized voice or by data.

The T1 signal originally used a type of framing known as D4 superframe, which identifies how the T1 is multiplexed. Extended superframe (ESF) is an enhancement of that framing format. ESF provides a non-disruptive means of full-time monitoring on the facility datalink (FDL). The service providers originally used ESF to monitor the performance of their service offering. Since the introduction of ESF, equipment that is installed in private networks can also provide the same performance information to the user.



## Fractional T1

Fractional T1 (FT1) lets the buyer purchase less than a full T1 circuit between two points. Most carriers offer fractional T1 in increments of 56 or 64 kbps. Connection is made to the same network elements. The network allows multiple users to share the same interoffice T1 bandwidth.

FT1 remains almost exclusively an inter-exchange carrier (IXC) service. Local exchange carriers (LECs) typically do not offer FT1, so the user's proximity to the IXC's point-of-presence (POP) is key in the savings that fractional T1 offers.

## SNMP MANAGEMENT

SNMP management capability is provided in-band with support for RFC 1315 (frame relay DTE MIB), RFC 1213 (MIB II), RFC 1406 (DS1/E1 MIB), and ADTRAN Enterprise MIB. MIB files are available from ADTRAN in the support section of the ADTRAN web page at [www.adtran.com](http://www.adtran.com). TELNET capability is also supported. For non-SNMP environments, VT-100 and front panel operation are supported.

The TSU IQ Rackmount's embedded SNMP feature allows the unit to be accessed and controlled by a network manager in-band at the DTE or network interface, out-of-band at the control port via SLIP or async PPP, or using a LAN connection.

The term SNMP refers to the message protocols used to exchange information between the network and the managed devices, as well as to the structure of network management databases. The three basic components of SNMP follow:

### **Network Manager**

Control program that collects, controls, and presents data pertinent to the operation of the network devices. It resides on a network management station.

**Agent**

Control program that resides in each connected network device. This program responds to queries and commands from the network manager and returns requested information or invokes configuration changes initiated by the manager.

**MIB**

Index to the organized data within a network device. It defines the operation parameters that can be controlled or monitored.

**TELNET**

Telnet provides a password-protected, remote login facility to the TSU IQ Rackmount. TELNET allows a user on a network manager to control the TSU IQ Rackmount through the terminal menus.

**DIAL BACKUP OPERATION**

The TSU IQ Rackmount dial backup (DBU) option cards provide single or multiple site backup depending on the DBU card option selected. The TSU IQ Rackmount can be configured to originate a call based on physical layer conditions (i.e., port failures) and/or PVC outages. Once the criteria are met, the TSU IQ Rackmount establishes a call to the configured phone number and the connection is used to carry traffic for the PVC(s) configured for DBU operation.

In the case of PVC outages (not physical layer port failure), the TSU IQ Rackmount's two-port design allows the TSU IQ RM receiving the call to continue to use the T1 Frame Relay circuit for PVC's that are not affected by the outage while using the DBU interface for PVCs that are inactive due to the outage. A TSU IQ RM with multiple PVCs to multiple sites can also originate a call to one site during an outage and restore connection for PVCs to that destination.

The TSU IQ Rackmount's unique DBU cards are field-installable by the customer. The backup options are described in the following section, *Interface Card Options*.

Contact the local telco provider to determine which services are available in your area. See *Applications* on page 4-1 for more information, including examples of a dial backup application.

## **INTERFACE CARD OPTIONS**

### **DCE DBU Plug-On Card**

The ADTRAN DCE DBU card (P/N 1204006L1) provides an interface to an external DCE device, which then can be used for dial back-up access to the public switched telephone network (PSTN).

### **PRI DBU Plug-On Card**

The ISDN PRI Dial Backup card can backup multiple remote sites. The card can support up to 23 simultaneous calls as well as DS0 only (56K/64K) service per dial backup call. Receipt of bit-oriented messages and transmission of performance report messages (per ANSI T1.408) are supported, as well as line and payload loopback and dial backup error/failure notification.



## UNPACK, INSPECT, POWER UP

### Receipt Inspection

Carefully inspect the TSU IQ Rackmount for any shipping damage. If damage is suspected, file a claim immediately with the carrier and contact ADTRAN Customer Service. If possible, keep the original shipping container for use in shipping the TSU IQ Rackmount for repair or for verification of damage during shipment.

### ADTRAN Shipments Include

The following items are included in ADTRAN shipments of the TSU IQ Rackmount:

- TSU IQ Rackmount main card
- TSU IQ Rackmount rear interface card
- The User Manual
- An 8-position modular to 8-position modular cable and a modular to female DB-9 adapter for access to the Control/SLIP/PPP port



*The ADTRAN TSU IQ Rackmount MIB is available from ADTRAN in the support section of the ADTRAN web page at [www.adtran.com](http://www.adtran.com).*

## Customer Provides

The customer must provide a male V.35 interface cable.

For SNMP management not accessed through the DTE or network port, the customer must provide access to the TSU IQ Rackmount either through a SLIP port, Async PPP port (requires a male 25-pin D-type connector), or a 10BaseT ethernet port. See *Pinouts* on page A-1 for the pin assignments of the control port (for SLIP and Async PPP) and the ethernet port.

## REAR INTERFACE CARD

The rear interface card contains a DTE connector which provides a primary channel V.35. An 8-pin network jack, test jacks, a PRI DBU port, a DTE DBU Port, and a 10BaseT ethernet port are also located on the rear panel. Pin assignments for these connectors are listed in *Pinouts* on page A-1. The TSU IQ Rackmount rear panel is shown in Figure 2-1 on page 2-3.

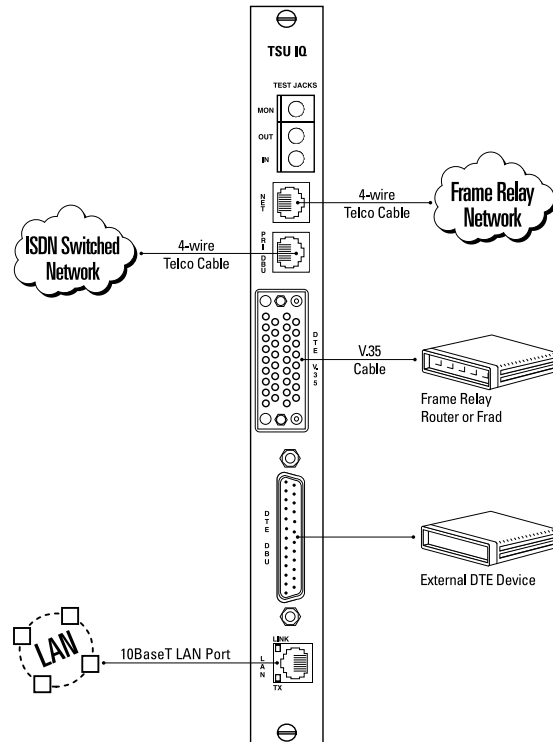

Item	Function
<b>Test Jacks</b>	Connect to a monitoring device or a T1 test set
<b>Network</b>	Connects to dedicated circuit
<b>PRI DBU</b>	Provides interface to optional PRI DBU plug-on module
<b>DTE V.35</b>	High-speed DTE interface
<b>DTE DBU</b>	Provides interface to optional external DTE DBU plug-on module
<b>LAN</b>	10BaseT ethernet interface

Figure 2-1. TSU IQ Rackmount Rear View

## Test Jacks

### Monitor

The monitor jack (labeled **MON**) is used as a non-intrusive monitoring point for the data received from the network. The monitoring device needs to be set for high impedance bridge mode.

### In/Out

The In and Out jacks are used to connect to a T1 test set for testing the T1 interface of the TSU IQ Rackmount. These connections isolate the T1 interface from the RJ-45 telco jack.

## Network Connector: Network Interface Connection

The TSU IQ Rackmount has an 8-position modular jack labeled **NET**. The telco connector is used for connecting to the network. The pinout for this connector is listed in *Pinouts* on page A-1.

## PRI DBU Interface

The TSU IQ Rackmount has an 8-pin modular jack for use with the optional PRI DBU plug-on module. The pinout for this connector is listed in *Pinouts* on page A-1.



## V.35 Connector: DTE Data Connection

The DTE should be connected to the V.35 connector (labeled **DTE V.35**). The maximum cable length is 100 feet. The pin assignments for this connector are listed in *Pinouts* on page A-1.



*To prevent possible radio frequency interference emissions, a shielded cable is required.*

## DTE DBU Interface

The TSU IQ Rackmount has a female DB25 connector for use with the optional DTE DBU plug-on module. The pinout for this connector is listed in *Pinouts* on page A-1.

## LAN Interface

The LAN jack provides the 10BaseT ethernet interface to the TSU IQ Rackmount. Two LEDs located on the LAN jack, labeled **LINK** and **TX**, indicate the status of the ethernet link and if the TSU IQ Rackmount is transmitting ethernet traffic. The pinout for this connector listed in *Pinouts* on page A-1.

## POWER UP AND INITIALIZATION

When the TSU IQ Rackmount is plugged into the Smart 16 shelf, it will begin its initialization. This takes approximately 60 seconds. The LED patterns will indicate the stage of the initialization in progress. See Figure 2-2 on page 2-6.

Stage	1. LED Test	2. Flash Test		3. Data Bus Test	
LED Pattern	Scrolling	OK	FAILED	OK	FAILED
		●RS	○RS	●RS	○RS
		●CS	○CS	●CS	○CS
		●TD	○TD	●TD	○TD
		●RD	○RD	●RD	○RD
		○ERR	●ERR	○ERR	●ERR
		○ALM	●ALM	○ALM	●ALM
		○TST	●TST	○TST	●TST
		○DBU	●DBU	○DBU	●DBU

Stage	4. RAM Test		5. Initial. Code Space	6. Download TSU
LED Pattern	OK	FAILED		<i>FLASHING</i>
	●RS	○RS	●RS	●RS
	●CS	○CS	●CS	●CS
	●TD	○TD	○TD	●TD
	●RD	○RD	○RD	●RD
	○ERR	●ERR	○ERR	●ERR
	○ALM	●ALM	○ALM	●ALM
	○TST	●TST	●TST	●TST
	○DBU	●DBU	●DBU	●DBU

Stage	7. Initialize TSU	8. Check for DBU	9. Finished
LED Pattern			
	●RS	●RS	●RS
	●CS	●CS	●CS
	○TD	●TD	●TD
	○RD	○RD	●RD
	○ERR	○ERR	●ERR
	○ALM	●ALM	●ALM
	●TST	●TST	●TST
	●DBU	●DBU	●DBU

Figure 2-2. Power Up Test Sequence

**FRONT PANEL**

The TSU IQ Rackmount faceplate is shown below in Figure 3-1. Descriptions of each part of the front panel follow.

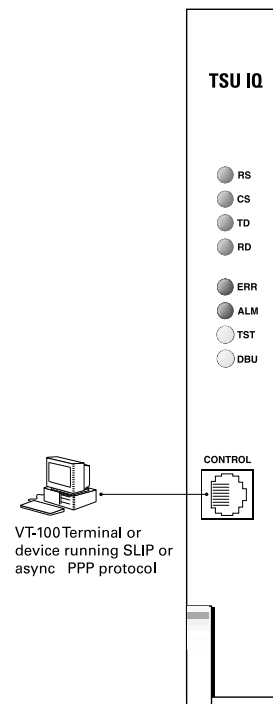

**Figure 3-1. TSU IQ Rackmount Faceplate**

## Control Port

The TSU IQ Rackmount has an 8-pin modular jack labeled **CONTROL**. The control port provides connection to a VT-100 EIA-232-compatible interface, a device running SLIP protocol, or a device running Async PPP protocol. An 8-foot cable with adapter connector provides a standard DB-25 EIA-232 interface. See *Pinouts* on page A-1 for the control port's pin assignments. This port's operation is described in *Operation* on page 3-1.

## LED Descriptions

The TSU IQ Rackmount has eight LED indicators: RS, CS, TD, RD, ERR, ALM, TST, and DBU. These LEDs are identified as follows:

**RS: Request to Send**

Reflects the status of the RS pin of the DTE interface.

**CS: Clear to Send**

Reflects the status of the CS pin of the DTE interface.

**TD: Transmit Data**

This LED is active when the TSU IQ Rackmount DTE port is transmitting data.

**RD: Receive Data**

This LED is active when the TSU IQ Rackmount DTE port is receiving data.

**ERR: Error**

This LED is active when a T1 line code violation or a T1 path code violation occurs.

**ALM: Alarm**

This LED is active when an alarm condition exists. Alarm conditions include:

## T1 Alarm Conditions

- Loss of signal
- Loss of T1 frame sync (red alarm)
- Receiving AIS (alarm indication signal) from the service provider

## Frame Relay Alarm Condition

- Network frame relay signaling state is down

**TST: Test**

This LED is active when the network interface is in a loopback condition triggered from the service provider.

**DBU: Dial Backup**

This LED indicates that the IQ is in a dial backup state.

## SMART 16/SMART 16E CONTROLLER CARD

The Smart16 shelf system uses the Smart16 or Smart 16e controller card to poll and access all cards in the shelf. Connection through the Smart16 controller card control port or the Datamate allows basic system-level configuration of the TSU IQ Rackmount.

The Smart16 Datamate port is located on the front of the controller card, and is labeled **LOCAL CONTROL**. The datamate provides access to controller configuration options, as well as options of the installed cards.

The Smart16 control port is located on the rear segment of the controller card and is labeled **DTE/DCE EIA-232**. The port is a standard VT-100 compatible interface which is configured via the Datamate (**UTILITIES** menu) for the Smart16 controller, or via DIP switch settings for the Smart16e controller. See the controller user manual for more information.

Access through the Smart16 controller card only allows for basic system-level configuration of the TSU IQ Rackmount, as shown in Figure 3-2. All other configuration is then accomplished through the TSU IQ Rackmount unit via one of the following:

- Local and remote VT-100 terminal via the control port on the front panel of the TSU IQ Rackmount card.
- Remote configuration via Frame Relay Network connection.
- TELNET and SNMP through SLIP/PPP or 10BaseT ethernet connection.
- Inband management through local, shared or dedicated PVCs.

1) IP ADDRESS	1) UNIT IP ADDRESS	
	2) SUBNET MASK	
	3) GATEWAY IP	
2) CONTROL PORT	1) PORT MODE	1) TERMINAL
		2) SLIP PROTOCOL
		3) PPP PROTOCOL
3) FACT RESTORE	2) BAUD RATE	1) 9600
		2) 19.2k
		3) 38.4k
	1) DO FACTORY RST	

**Figure 3-2. Menu Structure for Access via the Smart16 Controller**

---

## Menu definitions for Smart16 Controller Access

### IP Address

Enter the TSU IQ Rackmount IP (Internet Protocol) address, subnet mask, and gateway IP address. If access is via the Datamate, use the \* key as a decimal point. See *System Configuration* on page 9-1 for more information about these options.

### Control Port

#### Port Mode

Sets the TSU IQ Rackmount control port for terminal, SLIP protocol, or PPP protocol mode. Set for SLIP or PPP when using the control port for an SNMP/TELNET path.



*Changing this option will cause the unit to reset. Data and communications with the controller will be disrupted.*

#### Baud Rate

Sets the baud rate of the TSU IQ Rackmount control port (applies to terminal mode only).

### Factory Restore

Restores all configuration options to their factory default values.



*Choosing this option will cause the unit to reset. Data and communications with the controller will be disrupted.*

## VT-100 TERMINAL CONNECTION AND OPERATION

To control the TSU IQ Rackmount using a VT-100 terminal, follow this procedure:

Step	Action
1	Set the TSU IQ Rackmount baud rate to match the terminal through the Smart16 control port (located on the controller card rear interface card) or the Smart16 Datamate port (located on the front of the controller card). The default is 9600 and maximum rate is 38.4K.
2	Using the ADTRAN-provided VT-100 terminal adapter, connect the <b>COM</b> port of a VT-100 compatible terminal or equivalent to the eight-pin modular jack labeled <b>CONTROL</b> on the front of the TSU IQ Rackmount. This connection is used for both local and remote configuration.
3	Open the connection and press <b>Enter</b> repeatedly until the <b>LOGIN MENU</b> appears (Figure 3-3).  Choose either <b>LOCAL LOGIN</b> (Step 4) or <b>REMOTE LOGIN</b> (Step 5).
4	For <b>LOCAL LOGIN</b> , do the following: <ul style="list-style-type: none"> <li>a. Select <b>LOCAL LOGIN</b> to configure the TSU IQ Rackmount unit connected to the terminal.</li> <li>b. Enter the password. The factory default password is <b>adtran</b>. The <b>MAIN</b> menu will appear (Figure 3-4 on page 3-7).</li> <li>c. Make selections by entering the number corresponding to the chosen parameter. Press <b>ESC</b> to return to the previous screen.</li> </ul>

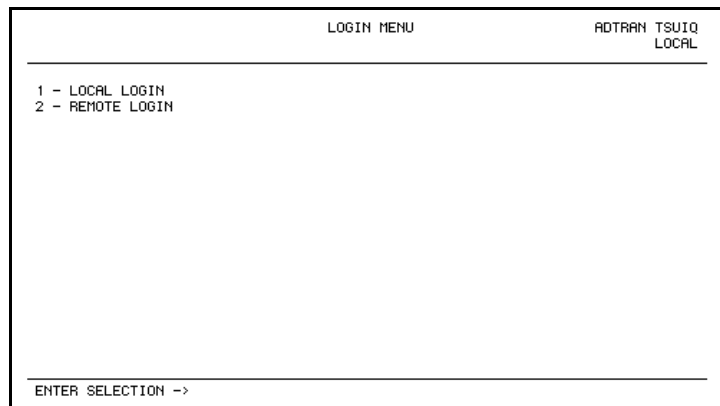

Figure 3-3. Terminal Login Menu



Step	Action
5	<p>For <b>REMOTE LOGIN</b>, do the following:</p> <ol style="list-style-type: none"> <li>a. Select <b>REMOTE LOGIN</b> to configure a remotely located TSU IQ Rackmount unit.</li> <li>b. For remote applications, at the remote DLCI prompt, enter the outgoing DLCI by pressing <b>1</b>, then <b>Enter</b>, entering the DLCI number, and pressing <b>Enter</b> again. (See the following note.)</li> <li>c. Select <b>BEGIN REMOTE SESSION</b> by pressing <b>2</b> and <b>Enter</b>.</li> <li>d. Enter the password. The factory default password is <b>adtran</b>. The <b>MAIN</b> menu will appear (See Figure 3-4).</li> <li>e. Make selections by entering the number corresponding to the chosen parameter. Press <b>ESC</b> to return to the previous screen.</li> <li>f. When entering the DLCI for a remote application, enter the DLCI associated with the local unit that you are logged in to (not the far end DLCI).</li> <li>g. If the wrong DLCI is entered or a network problem exists, the screen freezes at the <b>PRESS ANY KEY TO CONTINUE</b> prompt. Press <b>CNTL + L</b> twice to return the unit to the <b>LOGIN</b> screen.</li> </ol>



*In the upper right-hand corner of the VT-100 screen, **LOCAL** or **REMOTE** is displayed, indicating the unit the current screen represents. See Figure 3-4.*

```

MAIN MENU                                ADTRAN TSUIQ
                                           LOCAL
-----
1 - CONFIGURATION
2 - VIEW STATISTICS
3 - TEST
4 - DIAL
5 - LOGOUT

ENTER SELECTION -> _

```

**Figure 3-4. Terminal Main Menu**

## TSU IQ RACKMOUNT MENU STRUCTURE

The opening menu is the access point to all other operations. The **MAIN** menu branches are **CONFIGURATION**, **VIEW STATISTICS**, **TEST**, **DIAL**, and **LOGOUT**. See Figure 3-4 on page 3-7. Each **MAIN** menu item has several functions and submenus to identify and access specific parameters.

### Main Menu

Definitions for the branches of the **MAIN** menu follow:

#### **Configuration**

**CONFIGURATION** is used to select network, DTE, and system operating parameters. For more information on configuration options, see the following chapters: *Configuration Overview* on page 5-1, *DTE Port Configuration* on page 6-1, *Network Port Configuration* on page 7-1, *Dial Backup Options* on page 8-1 and *System Configuration* on page 9-1.

#### **View Statistics**

This selection displays statistical information for the DTE port, network port, dial backup port, and the system. See *Statistics* on page 10-1 for more information.

#### **Test**

**TEST** options allow you to perform PVC loopback tests. See *Testing* on page 11-1 for more information.

#### **Dial**

This selection allows you to access manual dialing capabilities. See *Activating Dialing Functions* on page 12-1 for more information.

#### **Logout**

This parameter logs out of the system.

This chapter provides examples of some common TSU IQ Rackmount management options as well as an example of a dial backup application. The management application examples include VT-100 management, out-of-band SNMP/TELNET management, and in-band PVC SNMP/TELNET management. Descriptions and configuration tips for these options are provided in the sections that follow.

**NOTE**

*The application drawings in this chapter show routers as the frame relay device. The frame relay device could be any device with frame relay capabilities. However, to use in-band management, the management DLCI must be RFC 1490 encapsulated IP traffic.*

## MANAGEMENT APPLICATIONS

One of the main advantages of the TSU IQ Rackmount is management flexibility. The management options described in this chapter provide configuration and diagnostics capabilities as well as all-inclusive statistics information.

### Local VT-100 Terminal Management

Connect a VT-100 terminal to the TSU IQ Rackmount **CONTROL** port. This interface provides full-screen configuration and all-inclusive statistics access. VT-100 management also allows for remote configuration. Through

this port, a remotely located TSU IQ Rackmount is fully accessible for configuration, diagnostics, and statistics viewing. Figure 4-1 shows an example of a VT-100 application.



*VT-100 remote mode is proprietary and non-intrusive. Therefore, you can perform all VT-100 management functions without disrupting the flow of data.*

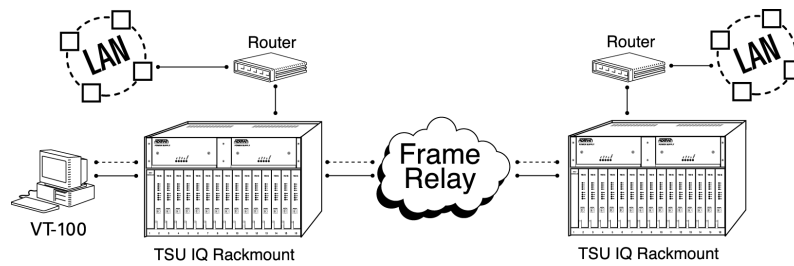

**Figure 4-1. VT-100 Management Application Example**

### Minimum Configuration Requirements for VT-100 Management

The following options are the minimum configuration requirements for establishing VT-100 management access.

#### Control Port Mode

Set the **CONTROL PORT MODE** for Terminal. This selection is found in the **SMART16 CONTROL PORT** or **DATAMATE** menu.

#### Baud Rate

Set the baud rate to match the VT-100 terminal rate. This is accessible from the Smart16 Controller Card Control port or **DATAMATE** only.

## Out-of-Band Management

This management option (shown in Figure 4-2) is commonly used in situations where the customer is trying to reduce the amount of management traffic flowing through the frame-relay device. The TSU IQ Rackmount can be managed through an established TELNET session or an SNMP-based network manager like HP OpenView®, IBM Netview®, or SunNet Manager®.



*The ADTRAN TSU IQ Rackmount MIB is available in the support section of the ADTRAN web page at [www.adtran.com](http://www.adtran.com).*

SNMP and TELNET management is provided by one of the following interfaces:

- A device (e.g., a router) running SLIP protocol. Connection is made through the TSU IQ Rackmount's **CONTROL** port.
- A device (e.g., a router) running async PPP protocol. Connection is made through the TSU IQ Rackmount's **CONTROL** port.
- A LAN. Connection is made through the 10BaseT ethernet interface.

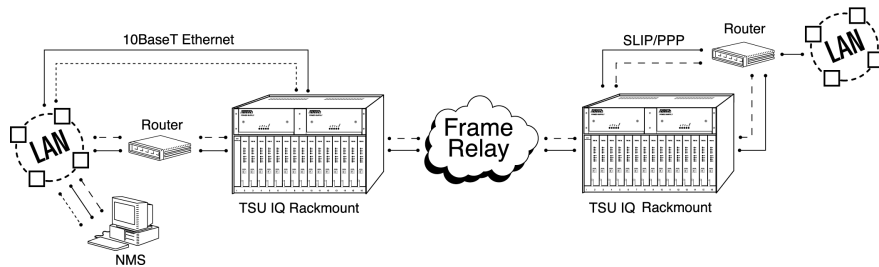

**Figure 4-2. Out-of-Band Management Application**

### Minimum Configuration Requirements for SNMP or Telnet Access

The following options are the minimum configuration requirements for establishing out-of-band SNMP or Telnet access. Once these options are configured, the unit may be accessed using SNMP/TELNET.

#### Control Port Mode

If necessary, select **SLIP** or **PPP** as the TSU IQ Rackmount control port mode. If the interface type is to be ethernet, this parameter does not affect setup.

#### IP Address

Enter the TSU IQ Rackmount IP address.

#### Subnet Mask

Enter the subnet mask number assigned to the network formed by the TSU and the other FRAD/routers across the frame relay network. This address is available from the network administrator.

#### Gateway IP Address (if required)

Enter the Gateway node IP address. This address is applicable only if the TSU IQ Rackmount and the network manager are connected through a Gateway node. This address is available from the network administrator.

The next five settings are applicable for SNMP access only.

#### Read Community Name

Set the **READ COMMUNITY NAME** to match the NMS (network management system) settings.

#### Write Community Name

Set the **WRITE COMMUNITY NAME** to match the NMS settings.

**Trap Manager DLCI**

Identify the virtual circuit used for all traps generated by the TSU IQ Rackmount. This selection is found under **CONFIGURATION>SYSTEM>TRAP MGR OPTIONS**.

**Trap Manager IP Address**

Enter the IP address of the SNMP manager to which the TSU IQ Rackmount sends traps. This selection is found under **CONFIGURATION>SYSTEM>TRAP MGR OPTIONS**.

**Trap Manager Port**

Enter the TSU IQ Rackmount port used to transmit traps to the SNMP manager. This selection is found under **CONFIGURATION>SYSTEM>TRAP MGR OPTIONS**.

**In-Band Management**

The ADTRAN TSU IQ Rackmount supports three modes of in-band management using the frame-relay structure of PVCs. These modes are *local*, *shared*, and *dedicated* PVC management and are described in the following sections. All three types support complete SNMP management as well as TELNET capabilities.



*All PVC-based in-band management traffic must be noncompressed IP and use RFC 1490 encapsulation.*

## Local PVC Management

Local PVC management refers to a PVC created between the TSU IQ Rackmount and the frame relay router on the DTE interface of the TSU IQ Rackmount (see Figure 4-3). This type of management is ideal when local management is needed but an ethernet connection is not available. To support this type of management, all traffic on the selected PVC must be RFC 1490 encapsulated, non-compressed IP traffic.

The local PVC is sent out of the WAN serial port of the router as normal WAN traffic and is terminated in the TSU IQ Rackmount. Since the TSU IQ Rackmount responds to Inverse ARP, it is not necessary to set up a static route in the router. The router will discover the IP address automatically; however, it will be necessary to set up a local PVC between the router and the TSU IQ Rackmount. This is done by setting a value (between 16 and 1007) for the DTE management DLCI on the TSU IQ Rackmount to a value not used by the frame relay network.

Local PVC management can be used at any location that has a router. Therefore, remote sites can be accessed through the remote router.

**WARNING** When using local PVC management, if the remote router goes down, access to the remote TSU is lost.

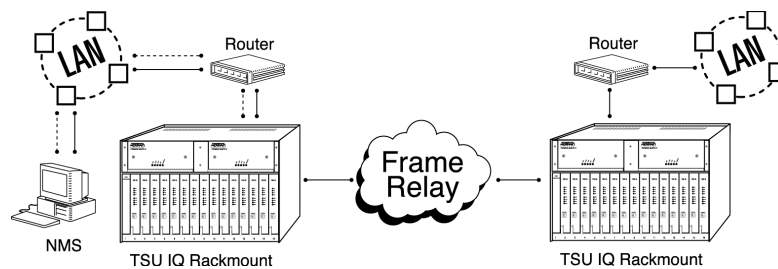

**Figure 4-3. Local PVC Management Application**



## Configuration Requirements for Local PVC Management

The following options are the minimum configuration requirements for establishing in-band local PVC management. Once these options are configured, the unit may be accessed using SNMP/TELNET. All options (with the exception of the **MANAGEMENT DLCI** option) are found under **CONFIGURATION>SYSTEM**.

### IP Address

Enter the TSU IQ Rackmount IP address.

### Management DLCI

Enter a DLCI number (between 16 and 1007) that is not used by the frame relay service. This option is found under **DTE PORT CONFIGURATION>FRAME RELAY OPTIONS**.

The next five settings are applicable for SNMP access only:

### Read Community Name

Set the **READ COMMUNITY NAME** to match the NMS settings.

### Write Community Name

Set the **WRITE COMMUNITY NAME** to match the NMS settings.

### Trap Manager DLCI

Identify the virtual circuit used for all traps generated by the TSU IQ Rackmount. This selection is found under **CONFIGURATION>SYSTEM>TRAP MGR OPTIONS**.

### Trap Manager IP Address

Enter the IP address of the SNMP manager to which the TSU IQ Rackmount sends traps. This selection is found under **CONFIGURATION>SYSTEM>TRAP MGR OPTIONS**.

**Trap Manager Port**

Enter the TSU IQ Rackmount port used to transmit traps to the SNMP manager. This selection is found under **CONFIGURATION>SYSTEM>TRAP MGR OPTIONS**.

**Shared PVC Management**

Shared PVC management refers to a PVC that is used for normal data traffic between locations (see Figure 4-4). The TSU IQ Rackmount monitors this PVC for packets that contain its IP address. When the TSU IQ Rackmount detects a packet containing a destination IP address that matches the TSU IQ Rackmount IP address, the unit intercepts the packet and processes its TCP/IP information. To support this type of management, all traffic on the selected PVC must be RFC 1490 encapsulated, noncompressed IP traffic.

Shared PVC management is used to manage remote TSU IQ Rackmounts without being dependent on services from the remote router. This usually requires a static route at the host location.



*By setting local PVC management and shared PVC management on the remote TSU IQ Rackmount, its IP address can be found through Inverse ARP. Since the unit is set up for shared PVC management, all management traffic will be intercepted prior to reaching the remote router.*

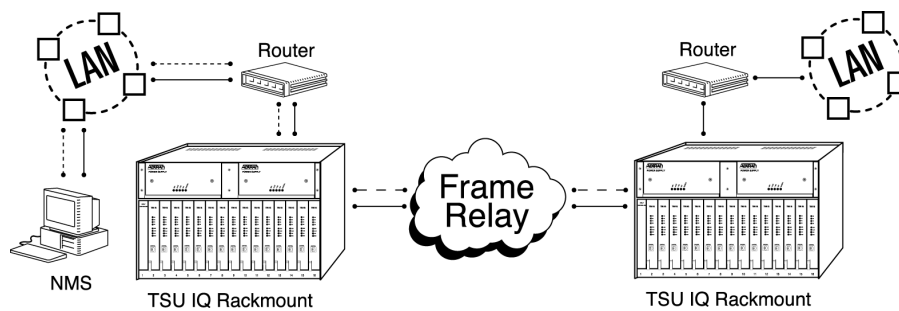

**Figure 4-4. Shared PVC Management Application**

## Configuration Requirements for Shared PVC Management

The following options are the minimum configuration requirements for establishing in-band shared PVC management. Once these options are configured, the unit may be accessed using SNMP/TELNET. All options (with the exception of the **MANAGEMENT DLCI** options) are found in the **SYSTEM** portion of the **CONFIGURATION** menu.

### IP Address

Enter the TSU IQ Rackmount IP address.

### Management DLCI 1 and/or DLCI 2

Enter the management DLCI(s) used to carry management traffic to and from the network. This option is found in the **NETWORK PORT CONFIGURATION** menu.

### Management DLCI 1 and/or DLCI 2 Mode

Set to **DEDICATED** if the management DLCI is used only to manage the TSU IQ Rackmount (and not used to carry customer traffic). If set to **DEDICATED**, the router is not notified of that DLCI. Set to **SHARED** if the DLCI is used to carry customer traffic as well as management data. This option is found in the **NETWORK PORT CONFIGURATION** menu.



*The TSU IQ Rackmount unit supports management from two network DLCIs either shared or dedicated.*

The next five settings are applicable for SNMP access only.

### Read Community Name

Set the **READ COMMUNITY NAME** to match the NMS settings.

### Write Community Name

Set the **WRITE COMMUNITY NAME** to match the NMS settings.

### Trap Manager DLCI

Identify the virtual circuit used for all traps generated by the TSU IQ Rackmount. This selection is found under **CONFIGURATION>SYSTEM>TRAP MGR OPTIONS**.

### Trap Manager IP Address

Enter the IP address of the SNMP manager to which the TSU IQ Rackmount sends traps. This selection is found under **CONFIGURATION>SYSTEM>TRAP MGR OPTIONS**.

### Trap Manager Port

Enter the TSU IQ Rackmount port used to transmit traps to the SNMP manager. This selection is found under **CONFIGURATION>SYSTEM>TRAP MGR OPTIONS**.

## Dedicated PVC Management

Dedicated PVC management refers to the ability to have a PVC originated from the network and terminated in the TSU IQ Rackmount (see Figure 4-5). This is an ideal configuration for third-party management. It isolates the customer's data traffic from network management traffic, and it also acts as a fire-wall that restricts management data to the TSU. Dedicated PVC management is also ideal when the user wants to guarantee access to a remote TSU regardless of the state of the remote LAN.

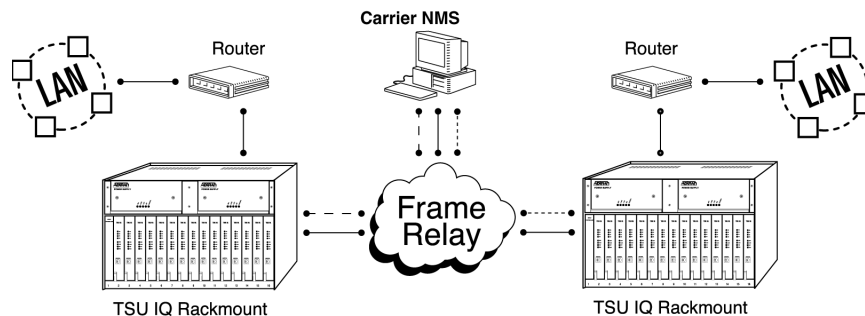

**Figure 4-5. Dedicated PVC Management Application**

**Configuration Requirements for Dedicated PVC Management**

The configuration requirements for dedicated PVC management are identical to those listed for shared PVC management. See the section *Configuration Requirements for Shared PVC Management* on page 4-9 for more information.

**DIAL BACKUP APPLICATION**

The TSU IQ Rackmount dial backup (DBU) option cards provide single or multiple site backup, depending on the DBU card option selected. The TSU IQ Rackmount can be configured to originate a call based on physical layer conditions (i.e., port failures) and/or PVC outages. Once the criteria are met, the TSU IQ Rackmount establishes a call to the configured phone number (see Table 4-1 on page 4-14) and the connection is used to carry traffic for the PVC(s) configured for DBU operation.

In the case of PVC outages (not physical layer port failure), the TSU IQ Rackmount's two-port design allows the TSU IQ Rackmount receiving the call to continue to use the T1 frame relay circuit for PVCs that are not affected by the outage. This is done (without the attached DTE device's intervention) by modifying the status of PVCs that are in DBU state to active when the PVC status is given to the DTE.

A TSU IQ Rackmount with multiple PVCs to multiple sites can also originate a call to one site during an outage and restore connection for PVCs to that destination. With all DBU cards except for the PRI card, you can make only one call at a time. The other PVCs to other sites in this scenario will be inactive. If you have a PRI card you can originate or answer up to 23 calls.

Information entered into the PVC Configuration table (see Table 4-2 on page 4-14) marks PVCs for DBU operation. The key element in each entry of the table is the DBU DLCI. For each PVC connecting two sites for DBU operation, the DLCI field represents the PVC DLCI

at the local UNI and the DBU DLCI represents the PVC DLCI at the remote site UNI. The TSU IQ Rackmount uses this information in the outbound side to change the PVC DLCI so the far end DTE device receives frames on the DBU PVC addressed in the same manner as when the frame relay circuit is operational. For PVCs not used for DBU operation, leave the **DBU PHONE NUMBER** field set for a null entry. Enter a space character from the VT-100 terminal to create a null entry for **DBU PHONE NUMBER** field.

The DBU phone number information is only required for the TSU IQ Rackmount originating the call.

Examples of dial backup for non-PRI and PRI, are shown in the following sections.



*The configuration selections given may need modification based on your network configuration.*

### DBU Application 1 (non-PRI)

The following application shows the critical configuration required for a case where all end points of the frame circuit are equipped with single call DBU units (see Figure 4-6). This setup allows any remote site to place a call to the host site or the host site to place a call to each remote site based on PVC failure. This setup also allows the host to design primary and alternate sites to call based on port failure criteria using the call order parameter.

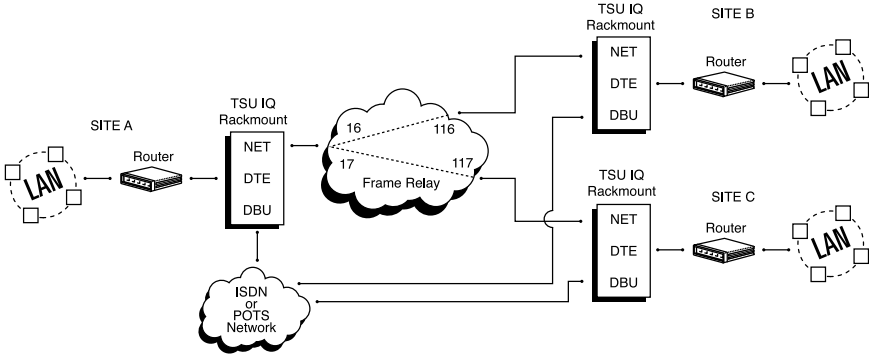

Figure 4-6. Dial Backup Application (non-PRI)

Table 4-1 on page 4-14 provides an example setup for the **DBU OPTIONS (CONFIG>DIAL BACKUP)**.

Table 4-2 on page 4-14 provides an example setup for the **PVC CONFIGURATION TABLE (CONFIG>NETWORK PORT>PVC CONFIG)**.

The tables are based on the example application shown in Figure 4-6.

Table 4-1. Example Settings for DBU Options

Option	Settings
<b>AUTO DBU</b>	Enable
<b>DBU Criteria</b>	With Network Fail: Enable With No LMI: Enable With PVC Inactive: Enable

Table 4-2. Example Settings for PVC Configuration Table

	<b>SITE A (ENTRY #1)</b>	<b>SITE A (ENTRY #2)</b>	<b>SITE B</b>	<b>SITE C</b>
<b>DLCI</b>	16	17	116	117
<b>DBU DLCI*</b>	116	117	16	17
<b>DBU Phone #**</b>	Site B #	Site C #	Site A #	Site A #
<b>DBU Call Order</b>	1	2	None	None
<b>DBU on Inactive***</b>	Enabled	Enabled	Enabled	Enabled

- \* DBU DLCIs and DBU phone number must be entered to provide dial back-up for a DLCI.
- \*\* DBU Phone # -- All DLCIs to the same site should have the same phone number.
- \*\*\* See *DBU on Inactive* on page 7-7.



### DBU Application 2 (PRI)

The following application shows the critical configuration for a case where the Host site of the frame relay circuit is set up to restore service (see Figure 4-7). This setup uses a PRI ISDN module and service so that multiple calls can be placed simultaneously. The criteria for placing a call are based on the Host Site port failure or individual PVC failure. The individual PVC failure should account for remote sites port outages and frame relay service troubles.

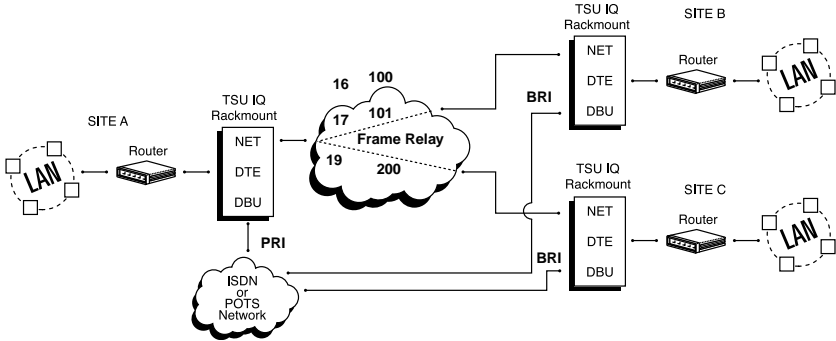

Figure 4-7. PRI DBU Card at Host Site (A)

Figure 4-7 on page 4-15 shows an example of the PRI DBU card at the Host site.

Table 4-3, Table 4-4, and Table 4-5 on page 4-16 show example setups for PRI DBU options at the Host site.

These tables are based on the example application shown in Figure 4-7.

**Table 4-3. Example Settings for PRI DBU Card (A)**

<b>AUTO DBU</b>	Enable
<b>DBU Criteria</b>	With Network Fail: Enabled With No LMI: Enabled With PVC Inactive: Enabled

**Table 4-4. Global DBU Settings (B and C)**

<b>AUTO DBU</b>	Enable
<b>DBU Criteria</b>	With Network Fail: Disabled With No LMI: Disabled With PVC Inactive: Disabled

**Table 4-5. Example Settings for PRI DBU Card at Host Site**

	<b>SITE A (ENTRY #1)</b>	<b>SITE A</b>	<b>SITE A</b>
<b>DLCI</b>	16	17	19
<b>DBU DLCI*</b>	100	101	200
<b>DBU Phone #**</b>	Site B #	Site B #	Site C #
<b>DBU on Inactive***</b>	Enabled	Enabled	Enabled

- \* DBU DLCIs and DBU phone number must be entered to provide dial backup for a DLCI.
- \*\* DBU Phone # -- All DLCIs to the same site should have the same phone number.
- \*\*\* See *DBU on Inactive* on page 7-7.

## Chapter 5 Configuration Overview

---

### LOCAL AND REMOTE CONFIGURATION

The TSU IQ Rackmount can be configured locally or communications can be established so that a local TSU IQ Rackmount can configure a remote TSU IQ Rackmount using a VT-100 interface. See *Operation* on page 3-1 for information on selecting **LOCAL** or **REMOTE** operation.

The **CONFIGURATION** menu consists of submenus relating to specific interfaces or functions of the TSU IQ Rackmount requiring setup:

- DTE Port
- Network Port
- Dial Backup (if DBU card is installed)
- System

For detailed information on configuration, see *DTE Port Configuration* on page 6-1, *Network Port Configuration* on page 7-1, *Dial Backup Options* on page 8-1, and *System Configuration* on page 9-1.

The **CONFIGURATION** menu tree is shown in Figure 5-1 on page 5-2.

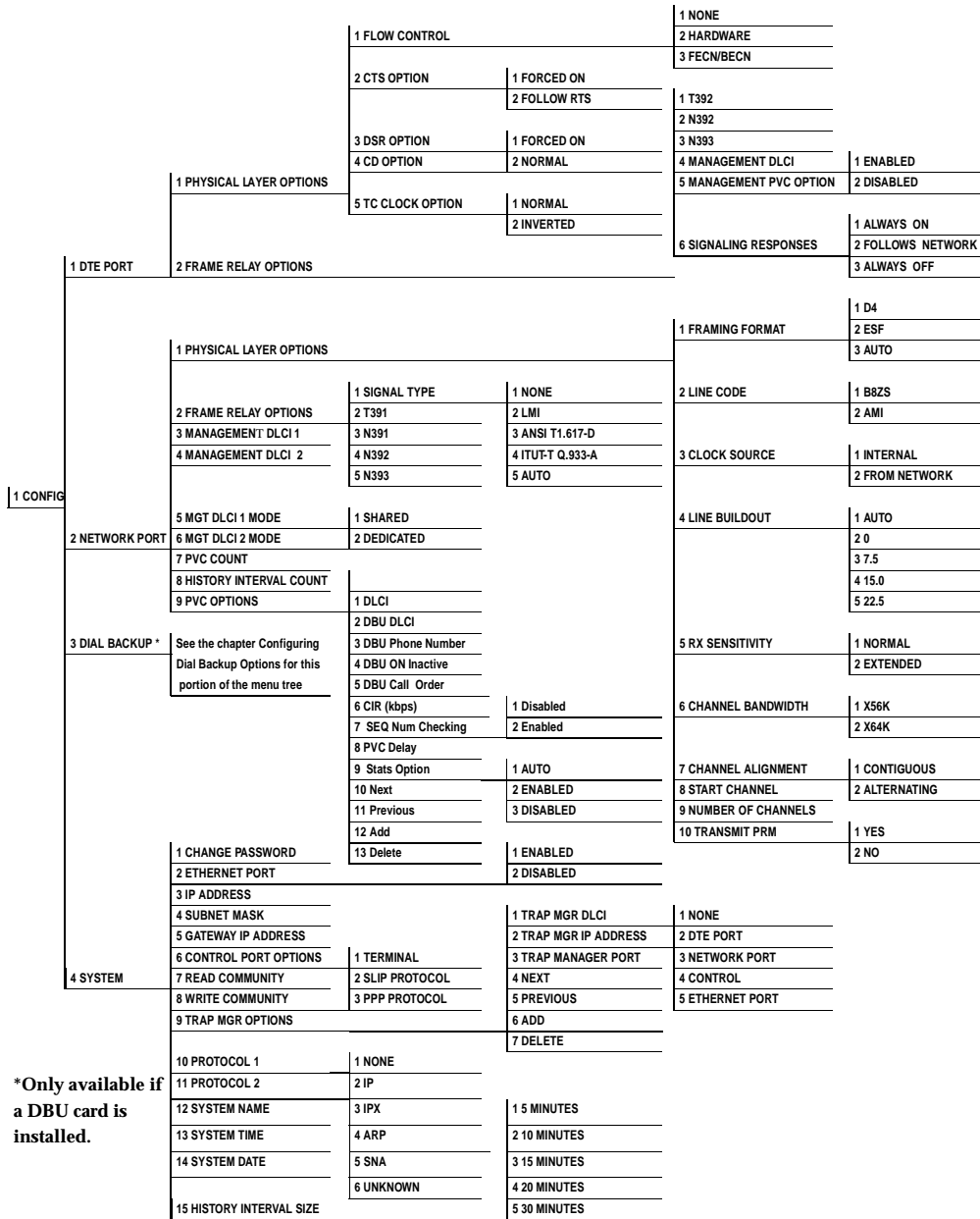

\*Only available if a DBU card is installed.

Figure 5-1. Configuration Menu Tree

Configure the physical layer and frame relay protocol options for the DTE port located on the rear of the TSU IQ Rackmount by selecting **DTE PORT** from the **CONFIGURATION** menu. Figure 6-1 illustrates the terminal **CONFIGURATION** menu for the DTE Port. The menu tree in Figure 6-2 on page 6-2 shows the choices available in this menu.

```
DTE PORT                CONFIGURE DTE PORT                ADTRAN TSUIQ
                                                                LOCAL
-----
1 - PHYSICAL LAYER OPTIONS
2 - FRAME RELAY OPTIONS

ENTER SELECTION -> _
```

**Figure 6-1. DTE Port Configuration Menu**

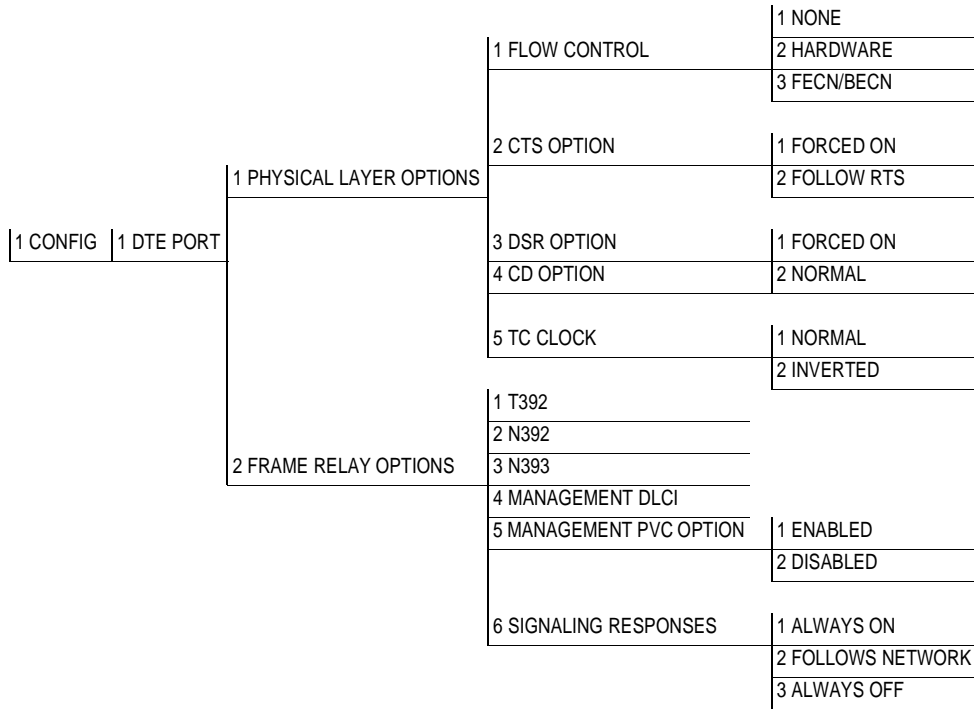

Figure 6-2. DTE Port Menu Tree

## Physical Layer Options

### Flow Control

This option determines how the TSU IQ Rackmount responds to congestion during DBU operation.

#### None

No flow control is used and the TSU IQ Rackmount drops frames during severe congestion while in DBU operation.

**Hardware**

The TSU IQ Rackmount varies the DTE TC clock as necessary to relieve congestion during DBU operation.

**FECN/BECN**

While in a congested state during DBU operation, frames across the DBU PVCs have **FECN** or **BECN** set depending on the direction. Frames outbound to the network have **FECN** set, while frames inbound to the attached DTE device have **BECN** set. This method is useful if the attached DTE devices can respond to congestion notification.

**CTS Option**

Set the CTS lead to **FORCED ON** or **FOLLOW RTS**.

**Forced On**

The CTS lead is always on and the RTS lead is ignored.

**Follow RTS**

The CTS lead is on when the RTS lead is on (and off when the RTS lead is off).

**DSR Option**

Set the DSR lead to **FORCED ON** or **NORMAL**.

**Forced On**

The DSR lead is always on.

**Normal**

The DSR lead is off when the TSU IQ Rackmount is in a loopback test or an alarm state.

**CD Option**

Set the CD lead to **FORCED ON** or **NORMAL**.

**Forced On**

The CD lead is always on.

**Normal**

The CD lead is off when the TSU IQ Rackmount is in alarm state.

**TC Clock Option**

**Normal**

Clock for DTEs transmit data normal phase.

**Inverted**

Clock for DTEs transmit data inverted phase. This setting may be used in high-speed circuits (>512 kbps) when the DTE's V.35 interface has high delay. This is usually indicated by HDLC errors on the IQ's DTE port.

**Frame Relay Options**

The frame relay protocol is a synchronous protocol used to concentrate two different devices into a common frame relay link to the network. The TSU IQ Rackmount accepts frame relay frames from a router or a FRAD (frame relay access device) and routes to/from the network port based on the DLCI address.

**T391**

Set the time-out (in seconds) between polling intervals. This parameter needs to be a few seconds longer than the **T391** setting of the attached frame relay device.

**N392 and N393**

These parameters define the error threshold for the UNI (user-to-network interface) formed by the TSU IQ Rackmount DTE port and the attached frame relay device. If the error threshold is met, the signaling state status is changed to **DOWN**, which indicates a service-affecting condition. This condition is cleared once **N393** consecutive error-free events are received. **N392** defines the number of errors required in a given event window, while **N393** defines the number of polling events in each window.



For example, if N392=3 and N393=4, then if three errors occur within any four events, the interface is determined inactive. The status of the connection can be viewed in the **STATUS** menu under **DTE PORT SIGNALING STATE**. The status will return to active once the threshold is no longer exceeded.

### Management DLCI

To use local PVC management, enter the management DLCI. The management DLCI is a special DLCI used between the attached DTE device and the TSU IQ Rackmount to carry SNMP and TELNET packets to and from the TSU IQ Rackmount on the DTE port.

#### Guidelines for Configuring Management DLCI

If the attached router or FRAD is used to route SNMP/TELNET frames to the TSU IQ Rackmount, set the **MANAGEMENT DLCI** to a unique value (between 16 and 1007) that identifies the virtual circuit between the router/FRAD and the TSU IQ Rackmount. The router/FRAD must also be configured to route the TSU IQ Rackmount IP address to this DLCI. The IP address and subnet mask for the DTE port must also be set in the **SYSTEM CONFIGURATION** menu.

### Management PVC Option

If this option is set to **ENABLED**, the management DLCI is included in the **FULL STATUS** response to the router. Enable this option when the management DLCI is used to route management traffic to the TSU IQ Rackmount.

### Signaling Responses

This option determines when PVC signaling responses are sent to the router.

#### Always On

If **ENABLED**, PVC signaling responses are sent to the router regardless of the network signaling state. Enable this option when the TSU IQ Rackmount is used for dial backup.

**Follow Network**

If **ENABLED**, PVC signaling responses are sent to the router only when the network signaling state is up. Enable this option when the router is going to use an alternate path for dial backup.

**Always Off**

If enabled, PVC signaling responses are not sent to the router, regardless of the network signaling state. Enable this option to simulate a PVC failure when the router is going to use an alternate path for dial backup.

## Chapter 7 Network Port Configuration

---

### NETWORK PORT

Access the network port menus by selecting **NETWORK PORT** from the **CONFIGURATION** menu. See Figure 7-1. Full menu trees for the **NETWORK CONFIGURATION** selections are shown in *Configuration Overview* on page 5-1. The network port terminates the user end of the frame relay UNI interface. The TSU IQ Rackmount supports three standard PVC signaling formats: LMI (gang of four), ANSI T1.617-D (Annex D), and ITU Q.933-A (Annex A). The selected signaling format is used to poll the network end of the UNI interface and retrieve virtual circuit information. Optionally, the polling process can be disabled.

```
NETWORK PORT          CONFIGURE NETWORK PORT          ADTRAN TSUIQ
                                                                LOCAL
-----
1 - PHYSICAL LAYER OPTIONS
2 - FRAME RELAY OPTIONS

3 - MANAGEMENT DLCI 1  1006
4 - MANAGEMENT DLCI 2  1005
5 - MGMT DLCI 1 MODE  SHARED
6 - MGMT DLCI 2 MODE  SHARED

7 - MAX PVC COUNT 20
8 - HISTORY INTERVAL COUNT  157

9 - PVC OPTIONS

ENTER SELECTION -> _
```

Figure 7-1. Network Port Configuration Menu

## Physical Layer Options

The following sections describe the physical layer options available for the network port.

### Framing Format

Sets the frame format for the NI (network interface). The available options are **D4**, **ESF**, and **AUTO**.



*D4 is equivalent to superframe format (SF).*

### Line Code

Sets the line code for the NI. Choose from **AMI** (alternate mark inversion) or **B8ZS**.

### Clock Source

Select the clock source to be derived from the network or from the unit. The selected clocking option designates the clock source for transmission. Clocking necessary for receiving data is recovered from incoming data. The available options are **INTERNAL** and **FROM NETWORK**.

### Line Buildout

Select the line buildout for the network interface. In **AUTO** mode, the TSU IQ Rackmount sets the LBO based on the strength of the receive signal. The available options are **AUTO**, **0**, **7.5**, **15**, and **22.5** dB.

### Rx Sensitivity

Selects the desired receiver sensitivity setting. The factory default is **NORMAL**, which is adequate for most applications. The **EXTENDED** setting should be used only in applications where the **NORMAL** setting is not sufficient. If the receive signal strength is less than -30 dB, choose **EXTENDED**.

### Channel Bandwidth

Sets the channel bandwidth for **56** or **64** kbps.

**Channel Alignment**

Sets the unit to use **ALTERNATING** or **CONTIGUOUS** channels in the T1 data stream. If more than 12 channels are used, then you must select **CONTIGUOUS**. If not, then you can use alternate channels to meet pulse density requirements (only necessary for Nx64 without B8ZS). If other than a private network, the carrier must be notified of this choice.

**Start Channel**

Selects the channel in which the T1 stream starts. The setting must be consistent with the carrier if using a public network.

**Number of Channels**

Selects the number of DS0s (channels) that are to be used. The corresponding DTE rate will be this number multiplied by 56K or 64K, depending on the channel bandwidth selected.

**Transmit PRM**

Enabling performance report messages allows the TSU IQ Rackmount to send messages across the facility data link (FDL) per ANSI T1.403. The terminating device at the telco may use this information for management of the T1 loop.

The TSU IQ Rackmount supports PRM messages per AT&T Pub 54016 which is a poll/response type protocol. Because of this poll/response nature, the transmit PRM option does not disable the TSU IQ Rackmount from processing or responding to 54016-type messages.

## Frame Relay Options

The terminal screen in Figure 7-2 appears when **FRAME RELAY OPTIONS** is selected from the **NETWORK PORT CONFIGURATION** menu.

```

NETWORK PORT          CONFIGURE FRAME RELAY PARAMETERS          ADTRAN TSUIQ
                                                                LOCAL
-----
1 - SIGNAL TYPE  AUTO
2 - T391        10
3 - N391         6
4 - N392         3
5 - N393         4

ENTER SELECTION -> _

```

**Figure 7-2. Network Port Frame Relay Options Menu**

### Signaling Type

Sets the signaling type option to match the network signaling type. Choices are **NONE**, **LMI** (gang of four), **ANSI T1.617-D** (Annex D), **ITU-T Q.933-A** (Annex A), or **AUTO**. **AUTO** mode forces the TSU IQ Rackmount to use the same signaling type as the attached frame relay DTE. If **AUTO** is selected and there is no DTE device attached, the TSU IQ Rackmount uses **ANSI T1.617-D** signaling type.

### T391

Sets the time (in seconds) between polls to the frame relay network.

### N391

Determine how many link integrity polls occur in between full status polls.

### N392 and N393

These parameters define the error threshold for the UNI formed by the TSU IQ Rackmount network port and the frame relay switch. If the error threshold is met, the signaling state status is changed to **DOWN**, which indicates a service-affecting condition. This condition is cleared once **N393** consecutive error-free events are received. **N392** defines the number of errors required in a given event window, while **N393** defines the number of polling events in each window.

For example:

If N392=3 and N393= 4, then if three errors occur within any four events the interface is determined inactive.

The status of the connection can be viewed in the **STATISTICS** menu under **NETWORK PORT SIGNALING STATE**. The status will return to active again once the threshold is no longer exceeded.



*The network service provider should recommend the values entered into the T391, N391, N392, and N393 fields.*

### Management DLCI 1 and 2

Enter the management data link connection identifiers (DLCIs). These DLCIs are used to carry management traffic to and from the network.

### Management DLCI 1 and 2 Mode

Set to **DEDICATED** if the management DLCI is used only to manage the TSU IQ Rackmount (and not used to carry customer traffic). If set to **DEDICATED**, the router is not notified of that DLCI. If set to **SHARED**, the management DLCI is used for carrying customer traffic and management data.

## Maximum PVC Count

Sets the maximum number of PVCs that the TSU IQ Rackmount will monitor for statistical information. This value determines the amount of history intervals available for storage. To get the maximum amount of statistical history storage, set this value equal to the number of PVCs assigned to the frame relay port. A smaller value increases history interval count but puts some of the PVC statistics into the unknown category.

## History Interval Count

Sets the number of history intervals to store for statistics. History intervals are displayed in the **VIEW BY INTERVAL** portions of the **STATISTICS** menus. These views provide data divided into columns grouped by the interval of time selected in the **HISTORY INTERVAL SIZE** field (see *System Configuration* on page 9-1 for more information). The **HISTORY INTERVAL COUNT** field determines how many intervals can be stored at a time. The maximum value allowed is affected by the previously mentioned PVC Count selection.

## PVC Options

The information in this menu must be entered for each PVC. DLCI numbers and their corresponding CIRs are provided by the service provider.

### DLCI

Enter the Network DLCI. Range is 16 to 1007.

### DBU DLCI

Enter the far end DLCI for each PVC used for dial backup. Only the TSU IQ Rackmount that originates the call is required to have this option set.



*Only PVCs that are used in DBU should have the DBU DLCI set to a non-zero value.*



The range for the DBU DLCI field is from 16-1007. Therefore, you cannot manually enter 0 for the PVCs not used in DBU. When an entry is first created with the **ADD** selection, it is set to 0 by default. To reset a previously configured DBU DLCI to 0, delete the entry and then add it back in (using the **DELETE** and **ADD** selections).

#### **DBU Phone Number**

The phone number entry stores the phone number that is used when the TSU IQ RM triggers auto dial backup in case of port or PVC failure. The phone number should correspond to a location that is equipped within "ADTRAN Safety Net" device that is capable of restoring the PVC which is designated by the DBU DLCI element. If auto dial backup is triggered by port failure, then the DBU call order element determines the order of a dialing list for alternate backup locations.

#### **DBU on Inactive**

This option works in conjunction with the DBU criteria option **WITH PVC INACTIVE**. For **DBU ON INACTIVE** option to have an effect on auto DBU operation, the **WITH PVC INACTIVE** option must be set to **ENABLE**. See **WITH PVC INACTIVE** on page 8-4.

If **DBU ON INACTIVE** is set for **ENABLED** and when the PVC designated by the DLCI element in the table entry goes to an inactive or unknown state, the TSU IQ RM will dial the phone number designated by the **DBU PHONE NUMBER** element in the table entry.

**GROUP** is a special case in which all PVCs that are part of a group must be inactive or unknown before the auto DBU process is triggered. This special case is treated as a port failure in which DBU call order entry applies.

#### **DBU Call Order #**

This determines the order in which a list of backup locations will be dialed. This applies only to auto DBU processes that are triggered by port failure. If all DBU call order entries are set to **NONE**, then the first entry with a DBU phone number will be used.

### **CIR (Kbps)**

Enter the CIR (committed information rate) in kbps for the corresponding DLCI. The information is provided by your service provider and must be entered for each PVC. Range is 0 to 1536.

### **Seq Num Checking**

Set to **ENABLE** only if there are TSU IQ units on both ends of the PVC. When enabled, the TSU IQ Rackmount tags each frame with a sequence number which is then used by the remote TSU IQ Rackmount to detect lost packets. Lost packet counts are given in the **STATISTICS** menus. Choices are **DISABLED** or **ENABLED**.

### **PVC Delay**

Set to **ENABLE** only if there are TSU IQ Rackmounts on both ends of the PVC.

When enabled, the TSU IQ Rackmount periodically transmits a loopback frame to the remote TSU IQ Rackmount which is then returned to measure round trip delay of each PVC.

Minimum, maximum, and average delay measurements are given in the **STATISTICS** menus.

### **Stats Option**

This option prioritizes PVCs for **STATISTICS** counts. The TSU IQ Rackmount tracks statistics for a limited number of the PVCs that pass through. This number is determined in the Max PVC Count field. See *Maximum PVC Count*, on page 7-6. The three choices for this field are described below.

#### **Auto**

If set to **AUTO**, statistics will be logged for this PVC if the **MAX PVC COUNT** has not been exceeded. The **AUTO** selection designates a PVC as second priority to a PVC set to **ENABLED**.

**Enabled**

If set to **ENABLED**, statistics will be logged for this PVC if the **MAX PVC COUNT** has not been exceeded. A PVC set to **ENABLED** is designated as a higher priority than one set to **AUTO**.

**Disabled**

If set to **DISABLED**, statistics will not be logged for this PVC at any time.



*If the TSU IQ RM encounters a PVC that has not been entered into the **PVC OPTIONS** table, the PVC is set to **AUTO** by default.*

**Next**

Edits the next entry in the PVC Options table.

**Previous**

Edits the previous entry in the PVC Options table.

**Add**

Adds a new entry to the PVC Options table.

**Delete**

Deletes the current entry in the PVC Options table.



## Chapter 8 Dial Backup Options

---

### DIAL BACKUP OPTIONS

The **DIAL BACKUP CONFIGURATION** menu (Figure 8-1) is available only when an optional DBU card is installed on the TSU IQ Rackmount. Use this menu to configure DBU options such as **AUTO DBU** capability, **DBU CRITERIA**, **DBU TIMER** functions, and **DBU** phone numbers. See Figure 8-2 on page 8-2 for a complete menu tree of the DBU selections.

CONFIGURE DIAL BACKUP	ADTRAN TSUIQ LOCAL
1 - AUTO DBU DISABLE 2 - DBU OPTIONS 3 - DBU CRITERIA 4 - DBU TIMERS 5 - DBU OPTIONS	
Enter Selection -> _	

**Figure 8-1. DBU Options Menu (DTE DBU Card Installed)**

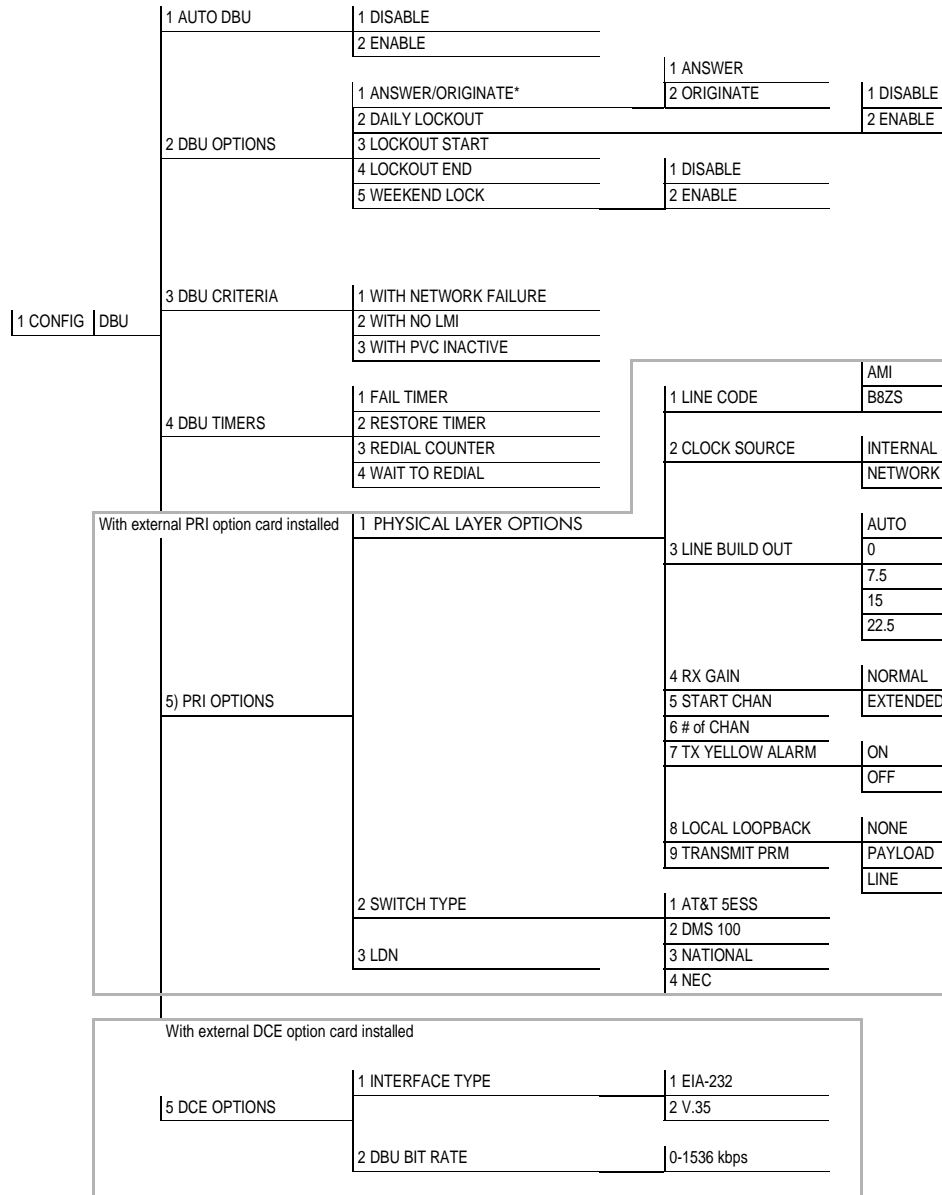

**Figure 8-2. Dial Backup Menu Tree**

\*Option only appears if signaling is turned off. See description on page 8-3 for more details.



*Dial backup is only supported when the unit is operated in point-to-point mode.*

## Auto DBU

The **AUTOMATIC DBU** option specifies whether the unit automatically enters dial backup mode or waits for manual setup. The factory default setting is **DISABLE**.

## DBU Options

### Answer/Originate

This option appears only if the TSU IQ Rackmount is being operated in a point-to-point mode (signaling is turned off). Set the unit either to originate a DBU call if conditions exist or to answer an incoming DBU call.

### Daily Lockout

Enable/disable the daily lockout specified by the fields **LOCKOUT START** and **LOCKOUT END**.

### Lockout Start

Enter the hour that the daily lockout begins and dial backup is disabled (0 to 23). This setting only applies if the **DAILY LOCKOUT** parameter is enabled.

### Lockout End

Enter the hour that the daily lockout ends and dial backup is reactivated (0 to 23). This setting only applies if the **DAILY LOCKOUT** parameter is enabled.

### Weekend Lock

If enabled, no backup will occur from midnight Friday to midnight Sunday.

## DBU Criteria

### With Network Failure

When enabled, the TSU IQ Rackmount enters backup mode when network failure is detected. The factory default setting is **ENABLE**.

### With No LMI

When enabled, the TSU IQ Rackmount enters backup mode when a loss of signaling from the frame relay switch is detected. The default setting is **ENABLE**.

### With PVC Inactive

This option works in conjunction with the **DBU ON INACTIVE** option in the PVC configuration table. The **WITH PVC INACTIVE** option acts as a master switch for auto DBU operation based on the PVC state. If this option is set to **ENABLED**, then each **DBU ON INACTIVE** option applies. If this option is set to **DISABLE**, then each **DBU ON INACTIVE** option is disabled.

## DBU Timers

### Fail Timer

This option sets the amount of time the dedicated circuit failure condition must be active before the TSU IQ Rackmount attempts backup. The value entered is multiplied by 10. The amount of time can be up to 990 seconds (i.e., an entry of 99). The factory default setting is 10 seconds (an entry of 1).

### Restore Timer

Once the T1 circuit is down, the TSU IQ Rackmount remains in backup until the T1 circuit is active for the length of time specified for the restore timer. The selection is entered in minutes (up to 255). If set to 0, the line must be restored manually. The factory default setting is 1 minute.

### Redial Counter

This option sets the number of times the TSU IQ Rackmount redials the far end when entering backup mode.



The redial count, which is manually entered, can be up to 99 attempts. If the TSU IQ Rackmount encounters a busy or reorder, it attempts to establish the call the specified number of times. The factory default setting is 5.

**Wait to Redial**

This option works in conjunction with the preceding **REDIAL COUNTER**. It selects the amount of time between redial attempts to connect the backup line. The amount of time, which is manually entered, can be up to 99 seconds. The factory default setting is 15 seconds.

**DBU Card Configuration Options**

The following selections are dependent upon the type of DBU card installed (if any). If no card is installed, the selections in this section do not appear.

**PRI Options**

The **PRI OPTIONS** field is available when the PRI DBU option card is installed.

**Physical Layer Options**

Selects the T1 physical layer options. Options include:

***Line Code***

Set the line coding of the PRI DBU card to **B8ZS** for PRI applications.

***Clock Source***

Set the clock source to be derived from the network or from the unit's internal clock. The selected clocking option designates the clock source for transmission. Clocking necessary for receiving data is recovered from incoming data. This option is most commonly set to **NETWORK**.

***Line Buildout***

Select the output level (in dB) for the PRI DBU card interface. Choices: **AUTO, 0, 7.5, 15.0, and 22.5** dB.

***Rx Gain***

Select the desired receiver sensitivity setting. The factory default setting is **NORMAL**, which is adequate for most applications. The **EXTENDED** setting should be used only in applications where the **NORMAL** setting is not sufficient. If the receive signal strength is less than 30 dB, choose **EXTENDED**.

***Start Channel***

Select the channel in which the T1 stream starts. The setting must be consistent with the carrier if using a public network.

***Number of Channels***

Select the number of DS0s (channels) that are to be used. Note that the PRI card uses one DS0 per connected call.

***Tx Yellow Alarm***

Set **TX YEL ALARM** to **YES** to transmit yellow alarms when a red alarm is detected. Set this entry to **NO** to avoid transmitting yellow alarms upon red alarm detection.

***Local Loopback***

This forces the PRI into loopback on the network. This option can be used instead of setting the loopback up using loop codes from external test equipment.

Options: **NONE**, **PAYLOAD**, and **LINE**.

***Transmit PRM***

Set this entry to **YES** to enable the unit to send messages across the facility data link (FDL) per ANSI T1.403.

### **Switch Types**

Selects which type of telco CO switch is providing the ISDN service. There are four options for PRI switch types:

- AT&T 5ESS
- DMS 100
- National
- NEC

### **LDN**

Enter the LDN for this location. This information is available from your service provider.

## **DCE Options**

The **DCE OPTIONS** field is available when the external DTE option card is installed.

### **Interface Type**

Selects the connector type for the DCE interface. Choices are **EIA-232** and **V.35**.

### **DBU Bit Rate**

Set to the operating speed of the DBU interface. Choices are **0** to **1536** kbps.



Access **SYSTEM** configuration selections by first choosing **CONFIGURATION** from the **MAIN** menu. Then choose **SYSTEM** from the **CONFIGURATION** menu. Full menu trees for the **SYSTEM** configuration selections are shown in Chapter 5, *Configuration Overview*, on page 5-1. The **SYSTEM** configuration menu is shown in Figure 9-1 on page 9-2.

## Change Password

Enter a new password of ten characters or less. The default password is **adtran**.

## Ethernet Port

Choose to either **ENABLE** or **DISABLE** the LAN 10BaseT ethernet port. Set to **DISABLE** if the TSU IQ RM's IP address is not a member of the local ethernet subnet.

## IP Address

Enter the TSU IQ Rackmount IP (internet protocol) address.

## Subnet Mask

Enter the subnet mask assigned to the LAN that the TSU IQ Rackmount is attached to.

```
CONFIGURE UNIT                                ADTRAN TSU IQ
                                                LOCAL
-----
1 - CHANGE PASSWORD
2 - ETHERNET PORT
3 - IP ADDRESS
4 - SUBNET MASK
5 - GATEWAY IP ADDRESS
6 - CONTROL PORT OPTIONS
7 - READ COMMUNITY
8 - WRITE COMMUNITY
9 - TRAP MGR OPTIONS
10 - PROTOCOL 1
11 - PROTOCOL 2
12 - SYSTEM NAME
13 - SYSTEM TIME
14 - SYSTEM DATE
15 - HISTORY INTERVAL SIZE
```

Figure 9-1. System Configuration Menu

## IP Address

Enter the IP address. The IP address is used when an ethernet packet is transmitted from the TSU IQ Rackmount to a foreign subnet. It is available only when the ethernet card is installed.

## Control Port Mode

Sets the **CONTROL** port for **TERMINAL**, **SLIP PROTOCOL**, or **PPP PROTOCOL** mode. Set for **SLIP** or **PPP** when using the **CONTROL** port for an SNMP/TELNET path.

## Read Community Name

Enter the authentication strings used for SNMP management. Match the TSU IQ Rackmount to the SNMP manager for read privileges.

## Write Community Name

Enter the authentication strings used for SNMP management. Match the TSU IQ Rackmount to the SNMP manager for write privileges.

## Trap Mgr Options

The **TRAP MANAGER OPTIONS** table defines routes for up to five SNMP managers.

### Trap Manager DLCI

If the trap manager port is set for **NETWORK** or **DTE**, this parameter identifies the virtual circuit used for all traps generated by the TSU IQ Rackmount.

### Trap Manager IP Address

Enter the IP address of the SNMP manager to which the TSU IQ Rackmount sends traps.

### Trap Manager Port

Enter the TSU IQ Rackmount port used to transmit traps to the SNMP manager. Choices are **NONE**, **DTE PORT**, **NETWORK PORT**, **CONTROL PORT**, and **ETHERNET PORT**.

### Next

Edit the next entry in the **TRAP MANAGER OPTIONS** table.

### Previous

Edit the previous entry in the **TRAP MANAGER OPTIONS** table.

### Add

Adds a new entry to the **TRAP MANAGER OPTIONS** table.

### Delete

Deletes the current entry in the **TRAP MANAGER OPTIONS** table.

## Protocols 1 and 2

These selections allow you to arm the TSU IQ Rackmount to gather statistics for particular protocols. Select the protocol types most commonly found on your network. If you have only one type, set **PROTOCOL 1** for that type and set **PROTOCOL 2** for Unknown. The information is displayed in the **LAYER 3** portion of the **STATISTICS** menu. See *Layer 3 Stats* on page 10-14. Descriptions for each of the six selections follow:

### None

Statistics are not gathered for that protocol number.

### IP

Statistical information for all IP protocol traffic (both routed and bridged) is gathered and displayed in the **LAYER 3** portion of the **STATISTICS** menu.

### IPX

Statistical information for all IPX protocol traffic (both routed and bridged) is gathered and displayed in the **LAYER 3** portion of the **STATISTICS** menu.

### ARP

Statistical information for all ARP protocol traffic is gathered and displayed in the **LAYER 3** portion of the **STATISTICS** menu.

### SNA

Statistical information for all SNA protocol traffic is gathered and displayed in the **LAYER 3** portion of the **STATISTICS** menu. All ten SNA types defined in FRF-3 are supported.

### Unknown

Statistical information for all other protocols (not selected in the other protocol field) is gathered and displayed in the **LAYER 3** portion of the **STATISTICS** menu.



## System Name

Enter the system name.

## System Time/Date

Sets the current hour, minute, day, month, and year. This is used to date/time stamp all statistical data captured by the TSU IQ Rackmount.

## History Interval Size

The time entered in this field affects the **INTERVAL VIEW** in the **STATISTICS** menus. The **INTERVAL VIEW** provides historical data for the current day. The data is divided into columns grouped by the interval of time (**5, 10, 15, 20, 25, or 30** minutes) selected in this field. The TSU IQ Rackmount stores up to 157 intervals. Once the maximum is reached, new information overwrites existing information, beginning with the least current.



*If data is not retrieved before the Total Time Stored is exceeded, it is overwritten and cannot be restored. Total Time Stored = History Interval Size x History Interval Count.*



## VIEWING STATISTICAL INFORMATION

Select **VIEW STATISTICS** from the **MAIN** menu to access the **VIEW STATISTICS** menu shown in Figure 10-1. From this menu, select to view statistics for the ports (**DTE**, **NETWORK**, or **DBU**), all available DLCIs, or the system. Select **RESET STATISTICS** to clear all current information.

```
VIEW STATISTICS MENU                                ADTRAN TSU IQ
                                                    LOCAL
1 - DTE PORT
2 - NETWORK PORT
3 - LAYER 3 STATS
4 - TOP TALKERS
5 - DBU PORT
6 - CALL MANAGER
7 - DLCI LIST
8 - SYSTEM
9 - RESET STATISTICS
```

**Figure 10-1. View Statistics Menu**

## Statistics Display Options

DTE port, network port, DBU port, and DLCI statistics are given in two formats: **VIEW BY INTERVAL** and **VIEW BY DAY**.

### View by Interval

In this view, the first column is a running total for the current day. All other columns are grouped into user-configured time frames with the most recent information displayed on the left. The first column's header displays the current date, and the interval columns display the time the intervals begin. To categorize the interval columns by date also, the midnight time stamp is replaced with the date. Note that this column still represents the timed interval (not a day's worth of information).

To configure the interval time frame, go to the **SYSTEM CONFIGURATION** menu under **HISTORY INTERVAL SIZE** and select the time you want the history interval to be set for (from 5 to 30 minutes, in five minute intervals). The TSU IQ Rackmount gathers and displays the information according to the time selected.

**NOTE**

*The TSU IQ Rackmount cuts the first gathering session short in order to begin falling on the selected time boundary.*

*For example: If the unit or the statistics information was last reset at 12:03 and the History Interval is set for five minutes, then the first interval session will last only two minutes. Therefore, the first interval column (i.e., the column farthest to the right if no columns have been deleted yet) normally represents a time shorter than the other columns.*

### View by Day

This view provides historical information for the last seven days (not including the current day). The most recent information is displayed on the left.

**NOTE**

*The first day's column (i.e., the column furthest to the right) does not represent a full day's worth of information (unless the unit or the statistics information was reset at **exactly 12 AM**).*

## Hot Keys

Once you have entered one of the statistics menus, hot keys are displayed across the bottom of the screen, allowing you to quickly access other menus or navigate within the current menu. These keys vary depending on the menu currently displayed.

### ESC=Menu

Press the **ESC** key to return to the main **VIEW STATISTICS** menu (shown in Figure 10-1 on page 10-1).

### D=DLCI

When viewing **NETWORK** port statistics, press **D** to view the **DLCI STATISTICS** menu shown in Figure 10-10 on page 10-25.

### Page (+, -)

Press the **+** and **-** keys to scroll through statistics menu pages.



*The **Shift** key must be used in conjunction with the **+** key in order to advance a menu page.*

### Scroll (<, >)

Press the **<** and **>** keys to scroll left and right on a statistics menu page.



*The **Shift** key must be used in conjunction with the **<** and **>** keys in order to scroll a menu page.*

### V=VIEW BY DAY/VIEW BY INTERVAL

Press **V** to change the view format.

The following sections describe the information given on the **DTE PORT**, **NETWORK PORT**, **DBU PORT**, **DLCI**, and **SYSTEM STATISTICS** menus.

## DTE Port Statistics

Information given is for the DTE port since the last reset. See Figure 10-2 below and Figure 10-3 on page 10-5 for the two **DTE PORT STATISTICS** screen formats.

### Leads On

If a lead has become active on the selected port since the last screen reset, it is listed in the **VIEW STATISTICS** menu. See Figure 10-2 below.

- RTS Request to send
- DTR Data terminal ready
- CTS Clear to send
- DSR Data set ready
- DCD Data carrier detect

DTE PORT	ADTRAN TSUIQ VIEW STATISTICS							LOCAL
Leads On -->	CTS	DSR	DCD	Interval		Remaining	134	
Signaling State -->	DOWN							
	JAN 25	18:00	17:55	17:53	0:00	0:00	0:00	
Loc PVC Rx Fr	0	0	0	0	0	0	0	
Loc PVC Rx Bt	0	0	0	0	0	0	0	
Loc PVC Tx Fr	0	0	0	0	0	0	0	
Loc PVC Tx Bt	0	0	0	0	0	0	0	
Sig Down Time	488	166	300	22	0	0	0	
Signal Error	0	0	0	0	0	0	0	
Signal T/O	32	10	18	4	0	0	0	
Sig State Chg	1	0	0	1	0	0	0	
Rx Full Stat	0	0	0	0	0	0	0	
Rx LI Only	0	0	0	0	0	0	0	
Discard Frame	0	0	0	0	0	0	0	
Aborts	0	0	0	0	0	0	0	
CRC Error	0	0	0	0	0	0	0	
Octet Align	0	0	0	0	0	0	0	
Length Error	0	0	0	0	0	0	0	
ESC = Menu    -, + = Page    >, < = Scroll    U = View By Day								

Figure 10-2. DTE Port Statistics (View by Day)

DTE PORT DAYS	ADTRAN TSUIQ VIEW STATISTICS						LOCAL
Leads On -->	CTS	DSR	DCD				
Signaling State -->	DOWN						
	NA	NA	NA	NA	NA	NA	NA
Loc PVC Rx Fr	0	0	0	0	0	0	0
Loc PVC Rx Bt	0	0	0	0	0	0	0
Loc PVC Tx Fr	0	0	0	0	0	0	0
Loc PVC Tx Bt	0	0	0	0	0	0	0
Sig Down Time	0	0	0	0	0	0	0
Signal Error	0	0	0	0	0	0	0
Signal T/O	0	0	0	0	0	0	0
Sig State Chg	0	0	0	0	0	0	0
Rx Full Stat	0	0	0	0	0	0	0
Rx LI Only	0	0	0	0	0	0	0
Discard Frame	0	0	0	0	0	0	0
Aborts	0	0	0	0	0	0	0
CRC Error	0	0	0	0	0	0	0
Octet Align	0	0	0	0	0	0	0
Length Error	0	0	0	0	0	0	0
ESC = Menu	D = DLCI	-,+ = Page		U = View Intervals			

**Figure 10-3. DTE Port Statistics (View by Interval)**

#### Interval Remaining

Number of seconds remaining in the current timed interval.

#### Signaling State

Indicates whether the frame relay signaling state is currently up or down.

#### Local PVC Rx Frames

Total frames received by the DTE port across the local management PVC.

#### Local PVC Rx Bytes

Total bytes received by the DTE port across the local management PVC.

#### Local PVC Tx Frames

Total frames transmitted by the DTE port across the local management PVC.

**Local PVC Tx Bytes**

Total bytes transmitted by the DTE port across the local management PVC.

**Signal Down Time**

Time in seconds the signaling state is down.

**Signal Error**

Number of signal frames received with PVC signaling protocol violations.

**Signal Timeouts**

Number of **T392** timeouts that have occurred.

**Signal State Change**

Number of changes in the signaling protocol state.

**Rx Full Status**

Number of full status polls received on the DTE side.

**Rx LI Only**

Number of link integrity (LI) only polls received on the DTE side.



**NOTE**

*On the DTE side, transmit and receive counts for full status and link integrity polls would be identical. Therefore, only receive counts are given.*

**Discard Frame**

Number of frames discarded by the TSU IQ Rackmount due to bad IP frames received on the management DLCI, transmission errors, or link violations. This count includes aborts, CRC errors, octet align, and length errors.

**Aborts**

Number of frames received without a closing flag. This transmission error is also reflected in the **DISCARD FRAME** field.



**CRC Errors**

Number of frames received with CRC violations. This transmission error is also reflected in the **DISCARD FRAME** field.

**Octet Align**

Number of frames received with a bit count that does not fall on 8-bit boundaries. This transmission error is also reflected in the **DISCARD FRAME** field.

**Length Error**

Number of frames received with fewer than 5 octets or greater than 4500 octets. This link violation is also reflected in the **DISCARD FRAME** field.

**EA Violation**

Number of frames received with an error in the extended address (EA) bit field of the frame relay header.

**Encapsulation Error**

Number of frames received on the management DLCI that have RFC 1490 errors.

**Inactive DLCI**

Number of frames received on an inactive DLCI.

**Invalid DLCI**

Number of frames received on a DLCI that is out of range. The valid DLCI range is 16-1007.

**Unrouteable**

Number of frames received on the management DLCI with an IP address that does not match the TSU IQ Rackmount IP address.

## Network Port Statistics

Information given is for the network port since the last re-set. See Figure 10-4 and Figure 10-5 for both formats of the NETWORK PORT STATISTIC screens.

Network Port	View Statistics				ADTRAN TSU IQ Local		
Signaling State --> DOWN				Interval Remaining			
TSU State --> OPEN LOOP				DTE DBU State --> IDLE			
	JAN 25	10:00	17:55	17:53	0:00	0:00	0:00
Rx Frames	0	0	0	0	0	0	0
Rx Bytes	0	0	0	0	0	0	0
Max Rx Thru	0	0	0	0	0	0	0
Avg Rx Thru	0	0	0	0	0	0	0
Max Rx Util %	0%	0%	0%	0%	0%	0%	0%
Avg Rx Util %	0%	0%	0%	0%	0%	0%	0%
Tx Frames	60	27	27	6	0	0	0
Tx Bytes	960	432	432	96	0	0	0
Max Tx Thru	128	128	128	128	0	0	0
Avg Tx Thru	11	12	11	11	0	0	0
Max Tx Util %	0%	0%	0%	0%	0%	0%	0%
Avg Tx Util %	0%	0%	0%	0%	0%	0%	0%
Port UA Time	655	287	300	68	0	0	0
Sig Down Time	614	287	300	27	0	0	0
Signal Error	0	0	0	0	0	0	0

ESC = Menu D = DLCI -, + = Page >, < = Scroll U = View By Day

Figure 10-4. Network Port Statistics (DBU Card Installed)

Network Port	View Statistics			ADTRAN TSU IQ Local	
Signaling State --> UP				Interval Remaining	1798
TSU state --> Open Loop				DTE DBU State --> Open Loop	
	Aug 11	11:00	10:30		
Rx Frames	0	0	0		
Rx Bytes	0	0	0		
Max Rx Thru	0	0	0		
Avg Rx Thru	0	0	0		
Max Rx Util %	0%	0%	0%		
Avg Rx Util %	0%	0%	0%		
Tx Frames	0	0	0		
Tx Bytes	0	0	0		
Max Tx Thru	0	0	0		
Avg Tx Thru	0	0	0		
Max Tx Util %	0%	0%	0%		
Avg Tx Util %	0%	0%	0%		
Port UA Time	2772	2	1800		
Sig Down Time	0	0	0		
Signal Error	0	0	0		

ESC = Menu D = DLCI -, + = Page >, < = Scroll U = View By Day

Figure 10-5. Network Port Statistics (View by Day)

**Signaling State**

Indicates whether the signaling state is currently up or down.

**Interval Remaining**

Number of seconds remaining in the current timed interval.

**TSU State**

Current state of the TSU. Possible states are listed in Table 10-1.

**Table 10-1. Possible TSU States**

<b>TSU STATE</b>	<b>DESCRIPTION</b>
OPEN LOOP	No receive signal
TEST FROM TELCO	Loopback code received from telco
AIS ALARM	Unframed all ones received
RED ALARM	Loss of frame synchronization
YELLOW ALARM	Telco side loss of frame asynchronization
ESF NORMAL	Normal condition for ESF link
D4 NORMAL	Normal condition for D4 link

**PRI State**

Current state of the PRI circuit (shows only if PRI card is installed.)

**DBU State**

Current state of the DBU circuit.

**Rx Frames**

Number of frames received by the network port.

**Rx Bytes**

Number of bytes received by the network port.

**Maximum Rx Throughput**

Maximum throughput sample in the receive direction for the given interval. This is displayed in kbps.

**Average Rx Throughput**

Average throughput in the receive direction for the given interval. This is displayed in kbps.

**Maximum Rx Utilization**

Maximum utilization sample in the receive direction for the given interval. Utilization is displayed as a percentage of network port bandwidth.

**Average Rx Utilization**

Average utilization sample in the receive direction for the given interval. Utilization is displayed as a percentage of network port bandwidth.

**Tx Frames**

Number of frames transmitted by the network port.

**Tx Bytes**

Number of bytes transmitted by the network port.

**Maximum Tx Throughput**

Maximum throughput sample in the transmit direction for the given interval. This is displayed in kbps.

**Average Tx Throughput**

Average throughput in the transmit direction for the given interval. This is displayed in kbps.

**Maximum Tx Utilization**

Maximum utilization sample in the transmit direction for the given interval. Utilization is displayed as a percentage of network port bandwidth.

**Average Tx Utilization**

Average utilization sample in the transmit direction for the given interval. Utilization is displayed as a percentage of network port bandwidth.

**Port UA Time**

Time in seconds the network port is unavailable for data delivery. This means that the T1 link is down or in test, or that the frame relay signaling state is down.

**Signal Down Time**

Time in seconds the signaling state has been down.

**Signal Error**

Number of signal frames received with PVC signaling protocol violations.

**Signal Timeouts**

Number of **T391** timeouts that have occurred.

**Signal State Change**

Number of changes in the signaling protocol state.

**Rx Full Status**

Number of full status responses received on the network side.

**Tx Full Status**

Number of full status polls transmitted by the TSU IQ Rackmount.

**Rx LI Only**

Number of link integrity (LI) only responses received on the network side.

**Tx LI Only**

Number of link integrity polls transmitted by the TSU IQ Rackmount.

**Async Status**

Number of asynchronous status messages received by the TSU IQ Rackmount.

**Discard Frame**

Number of frames discarded by the TSU IQ Rackmount due to bad IP frames received on the dedicated management DLCI, transmission errors, or link violations.

**Aborts**

Number of frames received without a closing flag. This transmission error is also reflected in the **DISCARD FRAME** field.

**CRC Errors**

Number of frames received with CRC violations. This transmission error is also reflected in the **DISCARD FRAME** field.

**Octet Align**

Number of frames received with a bit count that does not fall on 8-bit boundaries. This transmission error is also reflected in the **DISCARD FRAME** field.

**T1 State Change**

Count of state changes for the T1 port.

**T1 UA Time**

Time in seconds the T1 link is down.



*The next six parameters (**SIGNAL LOSS**, **TELCO TEST**, **AIS ALARM**, **RED ALARM**, **YELLOW ALARM**, and **PLL ALARM**) are events with two states: **ACTIVE** and **INACTIVE**. If the event occurs one or more times for the given interval, the field is active and **ALARM** is displayed. The first column of the View by Interval menu represents information for the entire current day. Therefore, once an alarm becomes active, it remains active in the first field for the entire 24-hour period.*

**Signal Loss**

If **ALARM** is displayed, a loss of signal occurred one or more times during the given interval.

**Telco Test**

If **ALARM** is displayed, a loopback code was received on the T1 interface one or more times during the given interval.

**AIS Alarm**

If **ALARM** is displayed, unframed all ones were received on the T1 interface one or more times during the given interval. This indicates that the T1 is out of service.

**Red Alarm**

If **ALARM** is displayed, a loss of frame synchronization occurred one or more times during the given interval.

**Yellow Alarm**

If **ALARM** is displayed, the telco end of the T1 was out of frame sync one or more times during the given interval.

**PLL Alarm**

**ALARM** displayed in this field usually signifies that both ends of the T1 circuit are set to provide timing.

**Path Code**

Number of path code violations. Path code violations include frame bit errors for D4 framing and superframes with CRC errors for ESF framing.

**Line Code**

Number of line code violations. Line code violations include BPVs that are not part of B8ZS code or excess zero violations.

**Length Error**

Number of frames received with fewer than 5 octets or greater than 4500 octets. This link violation is also reflected in the **DISCARD FRAMES** field.

**EA Violation**

Number of frames received with an error in the extended address (EA) bit field of the frame relay header.

**Encapsulation Error**

Number of frames received on a dedicated management DLCI that have RFC 1490 errors. These errors are also reflected in the **DISCARD FRAMES** field.



*If both management DLCIs are shared, the **ENCAPSULATION ERROR** field is not applicable. See the section *Management DLCI 1 and 2 Mode*, on page 7-5 in Chapter 7, for more information.*

**Inactive DLCI**

Number of frames received on an inactive DLCI.

**Invalid DLCI**

Number of frames received on a DLCI that is out of range. The valid DLCI range is 16-1007.

**Unrouteable**

Number of frames received on a dedicated management DLCI with an IP address that does not match the TSU IQ Rackmount IP address.



*If both management DLCIs are shared, the **UNROUTEABLE** field is not applicable. See the section *Management DLCI 1 and 2 Mode*, on page 7-5 in Chapter 7 for more information.*

## Layer 3 Statistics

Layer 3 statistical information shows what type of traffic is occupying the bandwidth. Configure this menu specifically for your setup by selecting the two protocol types most commonly found in your network. The selections are called **PROTOCOL 1** and **PROTOCOL 2** and are found in the **SYSTEM** portion of the **CONFIGURATION** menu (see page 9-4). Layer 3 tracking supports the following four protocols:

1. **IP (routed and bridged)**
2. **IPX (routed and bridged)**
3. **SNA (ten SNA types as defined in FRF-3)**
  - SNA-Subarea (FID4) with Layer 2 (LLC2)
  - SNA-Peripheral (FID2) with Layer 2 (LLC2)
  - SNA-APPN with Layer 2 (LLC2)
  - SNA-HPR with Layer 2 (LLC2)
  - SNA-Netbios with Layer 2 (LLC2)



SNA-Subarea (FID4) without Layer 2 (LLC2)  
 SNA-Peripheral (FID2) without Layer 2 (LLC2)  
 SNA-APPN without Layer 2 (LLC2)  
 SNA-Netbios without Layer 2 (LLC2)  
 SNA-HPR without Layer 2 (LLC2)

#### 4. ARP

For Layer 3 tracking to function, the data must be RFC-1490 encapsulated data or RFC-2427 encapsulated data (RFC-2427 superseded RFC-1490). For an IP packet to be recognized, it must be carried by an RFC-2427 IP header or an RFC-2427 SNAP header for bridged ethernet. If the SNAP header is carrying a bridged ethernet packet, the MAC header is examined for the protocol type. SNAP headers are also examined for IPX and ARP traffic.



*The ARP option actually tracks inverse ARP where addresses are resolved across the WAN link. SNA traffic is recognized by its RFC-2427 header.*

Information is gathered for the two protocol types you choose and is displayed with **P1** representing information for **PROTOCOL 1** and **P2** representing information for **PROTOCOL 2**.

There are four different views of the Layer 3 Statistics:

- Network Port, View by Interval
- Network Port, View by Day
- DLCI, View by Interval
- DLCI, View by Day

Descriptions of the fields found in these menus follow. Field descriptions are the same for both protocol selections, so “x” represents the protocol number.

#### **Px Type (current)**

The protocol type currently selected in the **CONFIGURATION** menu is displayed in this field.

**Interval Remaining**

Number of seconds remaining in the current timed interval.

**Px Type (listed for each interval)**

The protocol type being examined for the given interval is displayed in this field.



**NOTE**

When the **PROTOCOL** type selection is changed (see page 9-4), the new selection is not accepted by the TSU IQ Rackmount until the end of the current timed interval. For example, if the TSU IQ Rackmount is configured for 5-minute timed intervals, and the **PROTOCOL** type selection is changed at 12:25, the change will not be recognized until 12:30. This allows the unit to display an accurate interval history of the **PROTOCOL TYPE** field.



**NOTE**

When the **PROTOCOL** type selection is changed, the **PROTOCOL TYPE** field (**P1 TYPE** or **P2 TYPE**) for the current day total (left-most column on the **VIEW BY INTERVAL** screens) displays **MIXED**, indicating that the displayed information represents more than one protocol type. **Mixed** is also displayed for the day total on the **VIEW BY DAY** screen once the 24 hour period is complete.

**Px Rx Frames**

In the Network Port view, this is the number of frames received on the network port that match the selected protocol type. In the DLCI view, this is the number of frames received on a particular DLCI that match the selected protocol type.

**Px Rx Bytes**

In the Network Port view, this is the number of bytes received on the network port that match the selected protocol type. In the DLCI view, this is the number of bytes received on a particular DLCI that match the selected protocol type.

**Px Rx Dist%**

The distribution percentages show what portion of the data can be attributed to the protocols being tracked.

**Px Tx Frames**

In the Network Port view, this is the number of frames transmitted on the network port that match the selected protocol type. In the DLCI view, this is the number of frames transmitted on a particular DLCI that match the selected protocol type.

**Px Tx Bytes**

In the Network Port view, this is the number of bytes transmitted on the network port that match the selected protocol type. In the DLCI view, this is the number of bytes transmitted on a particular DLCI that match the selected protocol type.

**Px Tx Dist%**

The distribution percentages show what portion of the data can be attributed to the protocols being tracked.

## Top Talkers

The **TOP TALKERS STATISTICS** menu provides information regarding the top five talkers in each direction (Rx and Tx) based on their source IP addresses. This information is useful in diagnosing network problems.

If a user is experiencing slow response times, this screen shows whether the problem is the result of the line not having enough total bandwidth to support the number of users, or whether a small number of users are using excessive amounts of bandwidth.

*Lower distribution* percentages indicate that there are too many users for that line.

*High distribution* percentages indicate that some users may be using an excessive amount of bandwidth (possibly due to the type of applications they are using).

See Figure 10-6 for an example of a **TOP TALKERS** menu.

Top Talkers		View Statistics			ADTRAM TSUIQ Local	
Address Type --> IP		Interval Remaining 866				
		Aug 11		11:00	10:30	
1	Rx	0.	0.	0.	0.	0.
	Dist	0%		0.	0.	0.
2	Rx	0.	0.	0.	0.	0.
	Dist	0%		0.	0.	0.
3	Rx	0.	0.	0.	0.	0.
	Dist	0%		0.	0.	0.
4	Rx	0.	0.	0.	0.	0.
	Dist	0%		0.	0.	0.
5	Rx	0.	0.	0.	0.	0.
	Dist	0%		0.	0.	0.
1	Tx	0.	0.	0.	0.	0.
	Dist	0%		0.	0.	0.
2	Tx	0.	0.	0.	0.	0.
	Dist	0%		0.	0.	0.
3	Tx	0.	0.	0.	0.	0.

ESC = Menu      -, + = Page      >, < = Scroll      U = View By Day

**Figure 10-6. Top Talkers Menu**

#### Address Type

The **ADDRESS TYPE** field displays **IP**, indicating that the **TOP TALKERS** feature is tracking IP (routed and bridged) data.

#### Interval Remaining

Number of seconds remaining in the current timed interval (only shown in the **VIEW BY INTERVAL** screen).

#### Rx Distribution

Displays what percentage of the IP traffic received on the network port is from the given source address.

#### Tx Distribution

Displays what percentage of the IP traffic transmitted from the network port went to the given source address.

## DBU Port Statistics

Information given is for the dial backup port since the last reset. See Figure 10-7 and Figure 10-8 for both formats of the **DBU PORT STATISTICS** screens.

DBU PORT DAYS	View Statistics				ADTRAN TSU IQ Local		
DTE DBU State -> IDLE							
DBU Leads On -> CTS DSR							
	NA	NA	NA	NA	NA	NA	NA
Rx Frames	0	0	0	0	0	0	0
Rx Bytes	0	0	0	0	0	0	0
Max Rx Thru	0	0	0	0	0	0	0
Avg Rx Thru	0	0	0	0	0	0	0
Max Rx Util %	0%	0%	0%	0%	0%	0%	0%
Avg Rx Util %	0%	0%	0%	0%	0%	0%	0%
Tx Frames	0	0	0	0	0	0	0
Tx Bytes	0	0	0	0	0	0	0
Max Tx Thru	0	0	0	0	0	0	0
Avg Tx Thru	0	0	0	0	0	0	0
Max Tx Util %	0%	0%	0%	0%	0%	0%	0%
Avg Tx Util %	0%	0%	0%	0%	0%	0%	0%
Time in DBU	0	0	0	0	0	0	0
Discard Frame	0	0	0	0	0	0	0
Aborts	0	0	0	0	0	0	0
_ ESC = Menu    D = DLCI    -, + = Page    U = View Intervals							

Figure 10-7. DBU Port Statistics (View by Interval)

DBU Port	View Statistics			ADTRAN TSU IQ Local		
DTE DBU State --> Open Loop					Interval Remaining	667
DBU Leads On --> None						
	Aug 11	11:00	10:30			
Rx Frames	0	0	0			
Rx Bytes	0	0	0			
Max Rx Thru	0	0	0			
Avg Rx Thru	0	0	0			
Max Rx Util %	0%	0%	0%			
Avg Rx Util %	0%	0%	0%			
Tx Frames	0	0	0			
Tx Bytes	0	0	0			
Max Tx Thru	0	0	0			
Avg Tx Thru	0	0	0			
Max Tx Util %	0%	0%	0%			
Avg Tx Util %	0%	0%	0%			
Time in DBU	0	0	0			
Discard Frame	0	0	0			
Aborts	0	0	0			
ESC = Menu    -, + = Page    >, < = Scroll    U = View By Day						

Figure 10-8. DBU Port Statistics (View by Day)

**PRI Channels**

DS0 Channel identifier. (Channels 1 through 24). (PRI DBU only). See Table 10-2.

**Table 10-2. PRI Channel Descriptions**

This Channel...	Signifies that...
<b>D</b>	the DS0 is the active D channel
<b>A</b>	there is an active call on the DS0
.	the DS0 is assigned to the PRI interface but there is no active call.
-	the DS0 is unassigned to the Fractional PRI interface.

**PRI State**

Current state of the PRI Circuit. Possible states are listed in Table 10-3.

**Table 10-3. Possible PRI States**

PRI STATE	Description
<b>OPEN LOOP</b>	No receive signal
<b>TEST FROM TELCO</b>	Loopback code received from telco or manual loopback.
<b>AIS ALARM</b>	Unframed all ones received
<b>RED ALARM</b>	Loss of frame synchronization
<b>YELLOW ALARM</b>	Telco side loss of frame synchronization
<b>ESF NORMAL</b>	Normal condition for ESF link

**DS0 Status**

An **A** indicates the DS0 is being used to transfer data. A **D** indicates the D channel is up (PRI DBU only).

**DBU State**

Current state of the DBU circuit.

**Interval Remaining**

Number of seconds remaining in the current timed interval.

**Rx Frames**

Number of frames received by the DBU port.

**Rx Bytes**

Number of bytes received by the DBU port.

**Maximum Rx Throughput**

Maximum throughput sample in the receive direction for the given interval. This is displayed in kbps.

**Average Rx Throughput**

Average throughput in the receive direction for the given interval. This is displayed in kbps.

**Maximum Rx Utilization**

Maximum utilization sample in the receive direction for the given interval. Utilization is displayed as a percent of DBU port bandwidth.

**Average Rx Utilization**

Average utilization sample in the receive direction for the given interval. Utilization is displayed as a percent of DBU port bandwidth.

**Tx Frames**

Number of frames transmitted by the DBU port.

**Tx Bytes**

Number of bytes transmitted by the DBU port.

**Maximum Tx Throughput**

Maximum throughput sample in the transmit direction for the given interval. This is displayed in kbps.

**Average Tx Throughput**

Average throughput in the transmit direction for the given interval. This is displayed in kbps.

**Maximum Tx Utilization**

Maximum utilization sample in the transmit direction for the given interval. Utilization is displayed as a percent of DBU port bandwidth.

**Average Tx Utilization**

Average utilization sample in the transmit direction for the given interval. Utilization is displayed as a percent of DBU port bandwidth.

**Time in DBU**

Time in seconds that the DBU port was in DBU mode.

**Discard Frame**

Number of frames discarded by the TSU IQ Rackmount due to bad IP frames received on the dedicated management DLCI, transmission errors, or link violations.

**Aborts**

Number of frames received without a closing flag. This transmission error is also reflected in the **DISCARD FRAME** field.

**CRC Errors**

Number of frames received with CRC violations. This transmission error is also reflected in the **DISCARD FRAME** field.

**Octet Align**

Number of frames received with a bit count that does not fall on 8-bit boundaries. This transmission error is also reflected in the **DISCARD FRAME** field.

**T1 State Change**

Count of state changes for the T1 DBU port. (PRI DBU card only.)

**T1 UA Time**

Time in seconds the T1 DBU link is down. (PRI DBU card only.)



**Length Error**

Number of frames received with fewer than 5 octets or greater than 4500 octets. This link violation is also reflected in the **DISCARD FRAME** field.

**Encapsulation Error**

Number of frames received on a dedicated management DLCI that have RFC 1490 errors. These errors are also reflected in the **Discard Frame** field.



*If both management DLCIs are shared, the **ENCAPSULATION ERROR** field is N/A. See the section *Management DLCI 1 and 2 Mode*, on page 7-5 for more information.*

**Unrouteable**

Number of frames received on a dedicated management DLCI with an IP address that does not match the TSU IQ Rackmount IP address.



*If both management DLCIs are shared, the **UNROUTEABLE** field is not applicable. See the section *Management DLCI 1 and 2 Mode*, on page 7-5 for more information.*

## Call Manager

The **CALL MANAGER** statistics screen (shown and described in Figure 10-9) only applies to PRI dial backup configurations. The fields in this menu provide information regarding the 23 individual sites and PRI channels related to PRI dial backup.

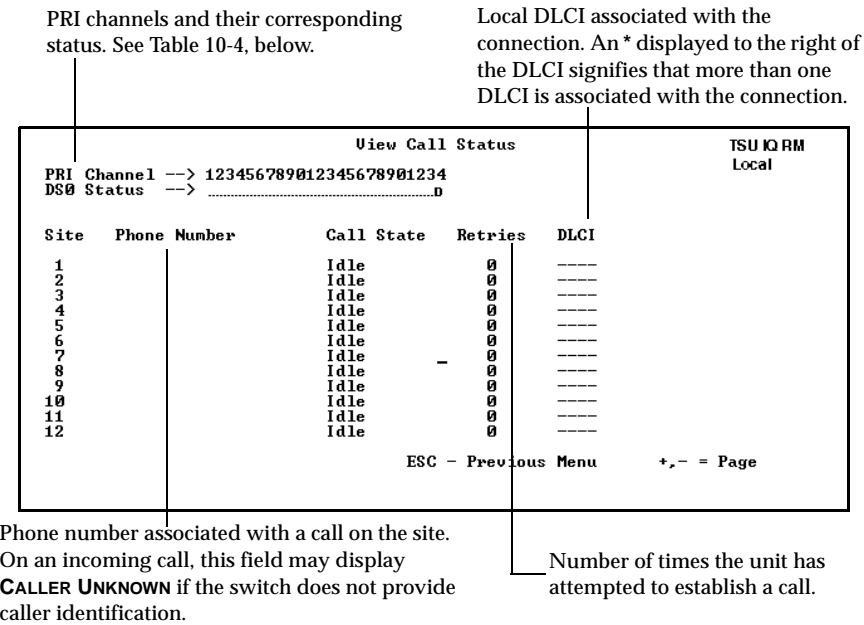

**Figure 10-9. Call Manager**

**Table 10-4. PRI Channels and Their Status**

This Channel....	Signifies that.....
<b>D</b>	the DS0 is the active D channel
<b>A</b>	there is an active call on the DS0
<b>.</b>	the DS0 is assigned to the PRI interface but there is no active call
<b>-</b>	the DS0 is unassigned to the fractional PRI interface.

## DLCI Statistics

Access specific DLCI statistics by pressing **D** from the **NETWORK STATISTICS** menu. Enter the DLCI number for information on a specific DLCI (displayed in the **VIEW BY INTERVAL** and **DAY** formats). For a status summary of all available DLCIs, select **DLCI LIST** from the **VIEW STATISTIC** menu shown in Figure 10-1 on page 10-1. Figure 10-10 shows the statistics menu for a specific DLCI.

VIEW STATISTICS						ADTRAN TSU IQ	
DLCI 100 A	Throughput: Tx 0 Rx 0				Remaining 239		Local
	Utilization: CIR not specified						
	JAN 25	18:05	18:00	17:55	17:53	0:00	0:00
Rx Frames	0	0	0	0	0	0	0
Rx Bytes	0	0	0	0	0	0	0
Max Rx Thru	0	0	0	0	0	0	0
Avg Rx Thru	0	0	0	0	0	0	0
Max Rx Util %	0%	0%	0%	0%	0%	0%	0%
Avg Rx Util %	0%	0%	0%	0%	0%	0%	0%
Tx Frames	2	2	0	0	0	0	0
Tx Bytes	18	18	0	0	0	0	0
Max Tx Thru	72	72	0	0	0	0	0
Avg Tx Thru	0	2	0	0	0	0	0
Max Tx Util %	0%	0%	0%	0%	0%	0%	0%
Avg Tx Util %	0%	0%	0%	0%	0%	0%	0%
Time in DBU	0	0	0	0	0	0	0
PVC IA Time	0	0	0	0	0	0	0
Rx FECN	0	0	0	0	0	0	0

ESC = Menu      -,+ = Page      >,< = Scroll      U = View By Day

Figure 10-10. DLCI Statistics for a Specific DLCI (View by Day)

### DLCI Statistics for a Specific DLCI

#### Throughput (Tx and Rx)

Displays the current throughput sample for this PVC.

#### Utilization

Displays the current CIR utilization sample for this PVC.

#### Remaining

Number of seconds remaining in the current timed interval.

**Rx Frames**

Number of frames received by the network port on the specified DLCI.

**Rx Bytes**

Number of bytes received by the network port on the specified DLCI.

**Maximum Rx Throughput**

Maximum throughput sample in the receive direction for the given interval. This is displayed in kbps.

**Average Rx Throughput**

Average throughput in the receive direction for the given interval. This is displayed in kbps.

**Maximum Rx Utilization**

Maximum utilization sample in the receive direction for the given interval. Utilization is displayed as a percentage of CIR.

**Average Rx Utilization**

Average utilization in the receive direction for the given interval. Utilization is displayed as a percentage of CIR.

**Tx Frames**

Number of frames transmitted by the network port on the specified DLCI.

**Tx Bytes**

Number of bytes transmitted by the network port on the specified DLCI.

**Maximum Tx Throughput**

Maximum throughput sample in the transmit direction for the given interval. This is displayed in kbps.

**Average Tx Throughput**

Average throughput in the transmit direction for the given interval. This is displayed in kbps.

**Maximum Tx Utilization**

Maximum utilization sample in the transmit direction for the given interval. Utilization is displayed as a percentage of CIR.

**Average Tx Utilization**

Average utilization sample in the transmit direction for the given interval. Utilization is displayed as a percentage of CIR.

**Time in DBU**

Time (in seconds) that the specified DLCI is in DBU mode.

**PVC IA Time**

Time in seconds that the PVC is in the inactive state.

**Rx FECN**

Number of frames received on the network port over the specified DLCI with the FECN bit of the frame relay header enabled.

**Tx FECN**

Number of frames transmitted from the network port over the specified DLCI with the FECN bit of the frame relay header enabled.

**Rx BECN**

Number of frames received on the network port over the specified DLCI with the BECN bit of the frame relay header enabled.

**Tx BECN**

Number of frames transmitted from the network port over the specified DLCI with the BECN bit of the frame relay header enabled.

**Rx DE**

Number of frames received on the network port over the specified DLCI with the discard eligibility (DE) bit of the frame relay header enabled.

**Tx DE**

Number of frames transmitted from the network port over the specified DLCI with the DE bit of the frame relay header enabled.

**Rx CR**

Number of frames received on the network port over the specified DLCI with the CR bit of the frame relay header enabled.

**Tx CR**

Number of frames transmitted from the network port over the specified DLCI with the CR bit of the frame relay header enabled.

**Lost Frames**

Number of frames lost across the PVC. This field is applicable only if the network port's **SEQUENCE NUMBER CHECKING** option (accessed through the **NETWORK PORT CONFIGURATION** menu) is **ENABLED**.

**Remote Lost Frames**

Number of lost frames reported by the remote TSU IQ Rackmount. This field is applicable only if the network port's **SEQUENCE NUMBER CHECKING** option (accessed through the **NETWORK PORT CONFIGURATION** menu) is **ENABLED**.

**Rx Burst Seconds**

Amount of time (in seconds) that throughput in the receive direction is greater than CIR.

**Tx Burst Seconds**

Amount of time (in seconds) that throughput in the transmit direction is greater than CIR.

**Minimum Rx Frame**

Size of smallest frame received across the DLCI.

**Maximum Rx Frame**

Size of largest frame received across the DLCI.

**Average Rx Frame**

Average size of frames received across the DLCI.

**Minimum Tx Frame**

Size of smallest frame transmitted across the DLCI.

**Maximum Tx Frame**

Size of largest frame transmitted across the DLCI.

**Average Tx Frame**

Average size of frames transmitted across the DLCI.

**Minimum Frame Delay**

Minimum round trip delay of the DLCI. This field is applicable only if the network port's **PVC DELAY MEASUREMENT** option (accessed through the **NETWORK PORT CONFIGURATION** menu) is **ENABLED**.

**Maximum Frame Delay**

Maximum round trip delay of the DLCI. This field is applicable only if the network port's **PVC DELAY MEASUREMENT** option (accessed through the **NETWORK PORT CONFIGURATION** menu) is **ENABLED**.

**Average Frame Delay**

Average round trip delay of the DLCI. This field is applicable only if the network port's **PVC DELAY MEASUREMENT** option (accessed through the **NETWORK PORT CONFIGURATION** menu) is **ENABLED**.

**PVC State Change**

Number of changes in the PVC state.

## DLCI List

This menu lists all available DLCIs and classifies them as **ACTIVE (A)**, **INACTIVE (I)**, or **UNKNOWN (U)**. See Figure 10-11. A byte and frame break out of each DLCI is also provided including an in/out count and a count of how many frames were received with **FECN**, **BECN**, or **DE** enabled.

ADTRAN TSUIQ VIEW DLCI STATISTICS							LOCAL	
DLCI	Frames		FECN	BECN	DE	Bytes		
	In	Out				In	Out	
100 A	0	2	0	0	0	0	18	
UNKNOWN	0	0				0	0	
INACTIVE	0	0				0	0	
SIGNAL	0	70				0	1120	

ESC = Prev Menu                      +, - = Page

**Figure 10-11. DLCI Statistics Summary for All Available DLCIs**



## System Statistics

The system time and date (as set in the **SYSTEM CONFIGURATION** menu) and the software revision are displayed in this menu. Also, the elapsed time since the unit was turned on (or since the last restart) is given in seconds. The buffer information provided in this menu is used mainly by ADTRAN technical support in troubleshooting situations. See Figure 10-12.

View System Statistics				ADTRAN TSUIQ (Local)	
Buf Type	Curr Use	Curr Free	Curr Use Per	High Buf Use	Avg Buf Use
1	45	209	17	48	45
2	0	5	0	3	0
3	0	20	0	1	0
4	0	200	0	1	0
5	0	88	0	0	0

System Time	---->	02:21
System Date	---->	FRI 05-07-99
Elapsed Time	---->	4443
Layer 3 Overruns	---->	0
S/W Revision	---->	1215

ESC - Stats Menu

Figure 10-12. System Statistics Screen



This menu allows you to perform diagnostics by initiating ping tests or PVC loopback tests. See Figure 11-1 for the **TEST** menu.

```
TEST MENU                                ADTRAN TSUIQ
                                         LOCAL
-----
1 - PING
2 - PVC LOOPBACK

-----
ENTER SELECTION ->
```

**Figure 11-1. Test Menu**

## Ping

Select **PING** to send a ping request to a specific address.

### Address to Ping

Enter the IP address of the unit the TSU IQ Rackmount is sending an echo request (ping) to.



*If the IP address is not manually configured into the IP route table, the path will be determined dynamically through RIP and inverse ARP protocols.*

### Start Ping

Results are shown once you start the ping. The **START PING** command causes the TSU IQ Rackmount to send ten ping requests to the target station. At the end of the ten-ping test, the following results are shown:

#### **Pings Transmitted**

This field shows the number of pings sent (always 10).

#### **Ping Responses**

This field shows the number of responses received from the pinged device.

#### **Min Response Time**

This field shows the shortest round-trip delay (in ms) of the received responses. Round-trip delay is counted from the time the ping is sent until the response is received.

#### **Max Response Time**

This field shows the longest round-trip delay (in ms) of the received responses. If a response is not received before the unit times out, the delay is not calculated in.

#### **Avg Response Time**

This field shows the average response time (in ms) based on all received responses.

### PVC Loopback

A PVC loopback test is a non-intrusive loopback option for each PVC. During this test, the TSU IQ Rackmount periodically sends test frames to the remote TSU IQ Rackmount which are then returned for analysis. The bandwidth required is approximately 1 kbps for each PVC in test. See Figure 11-2 for the terminal menu.

```
PVC LOOPBACK                                ADTRAN TSUIQ
                                              LOCAL
-----
1 - DLCI <0=ALL> 0
2 - TEST LEN : MIN <0=UNTIMED> 0
3 - START TEST
4 - STOP TEST
5 - VIEW TEST
6 - RESET TEST STATS
7 - VIEW DLCI LIST

-----
ENTER SELECTION -> _
```

**Figure 11-2. PVC Loopback Menu****Enter DLCI or 0 for All (DLCI)**

Enter the DLCI of the PVC to be tested (or enter **0** to test all available PVCs).

**Test Length**

Amount of time (in minutes) that you want the test to take place. Enter **0** for a continuous test.

**Start Test**

Starts the test.

**Stop Test**

Ends the test in progress prematurely or terminates a continuous test.

## View Test

Displays the **TEST STATISTICS** menu shown in Figure 11-3 on page 11-5. Descriptions of each field in the **TEST STATISTICS** menu follow.

### **PVC Active/Inactive/Undefined**

Displays current state of the selected PVC as determined by the switch.

- **Active:** The PVC is currently operational.
- **Inactive:** There is currently a physical or frame relay layer problem at the remote end of the PVC, or a problem exists inside the frame relay cloud for the selected PVC.
- **Undefined:** The PVC is undefined for the switch.

### **Test Active/No Test Active**

Displays current testing state of the TSU IQ Rackmount.

### **Frames Rx**

Number of frames received on the selected PVC during the current loopback test.

### **Frames Tx**

Number of frames transmitted across the selected PVC during the current loopback test.

### **Lost Frames**

Number of frames lost in the receiving direction (traveling from the remote TSU IQ Rackmount to the local TSU IQ Rackmount).

### **Remote Lost Frames**

Number of frames lost in the transmitting direction (traveling from the local TSU IQ Rackmount to the remote TSU IQ Rackmount).

### **Minimum Loop Response Time**

Minimum round-trip time (in seconds) for the current test.

**Maximum Loop Response Time**

Maximum round-trip time (in seconds) for the current test.

**Average Loop Response Time**

Average round-trip time (in seconds) for the current test.

```
VIEW TEST RESULTS                                ADTRAN TSUIQ
                                                LOCAL
-----
1 - DLCI <0=ALL> 100
PUC ACTIVE
NO TEST ACTIVE
FRAMES RX----->      0      FRAMES TX----->      0
LOST FRAMES----->    0      RMT LOST FRAMES --->    0
MIN LOOP RSP TIME->    0      MAX LOOP RSP TIME->    0
AVG LOOP RSP TIME->    0
-----
ENTER SELECTION ->
```

Figure 11-3. Test Status Screen

**Reset Test Stats**

Resets the information shown in the **TEST STATISTICS** menu.

**View DLCI List**

See the section *DLCI List* on page 10-30 for a description of this menu.





## Chapter 12 Activating Dialing Functions

---

### DIALING OPTIONS

The dial options available from the **MAIN** menu (**4=DIAL**) appear in Figure 12-1 and Figure 12-2.

4 DIAL	<u>Dial Backup Idle</u>	
	1 DIAL BACKUP	1 Enter Dial Number
		2 Dial Stored Number
	2 STAY ON LEASED LINE	
	<u>During Dial Backup</u>	
	1 DIAL BACKUP	1 Hang up
		2 Stay on line

**Figure 12-1. Dial Options Menu (non-PRI DBU)**

4 DIAL	<u>Dial Backup Idle</u>	
	1 DIAL BACKUP	1 Enter Dial Number
	<u>During Dial Backup</u>	
	1 DIAL BACKUP	1 Enter Dial #
		2 Hang up Phone #
		3 Hang up Site #*
		4 Hang up all calls

\*Can be obtained from View Statistics Call Manager Screen (VT-100 only).

**Figure 12-2. Dial Options Menu (PRI DBU)**

## Dial Options when Dial Backup is Idle

### Dial Backup

The TSU IQ Rackmount prompts to dial a stored number or enter a number to dial for dial backup.

### Stay on Leased

The TSU IQ Rackmount remains on the leased line and does not enter dial backup mode. (Does not apply to PRI card).

## Dial Options During Dial Backup

### Hang Up

Terminates the dial backup connection and attempts to reestablish communication on the T1 line.

### Stay On Line

This TSU IQ Rackmount remains in dial backup mode and returns to the **STATISTICS** menu.

The TSU IQ Rackmount prompts you to enter a number to dial for dial backup, or to hang up an existing call. The PRI card selections allow you to choose to hang up a single phone number, an individual site, or all calls at once. In all cases, once **HANG UP** is selected, the dial backup connection is terminated and the unit attempts to re-establish communication on the T1 line.

## Appendix A Pinouts

---

The following tables give the pin assignments for the TSU IQ Rackmount card connectors. For more information on these connectors, see *Installation* on page 2-1.

**Table A-1. Pin Assignments for Network Connector**

Pin	Name	Description
1	R1 RXDATA-RING	Receive data from the network
2	T1 RXDATA-TIP	
3	UNUSED	
4	R TXDATA-RING	Send data towards the network
5	T TXDATA-TIP	
6, 7, 8	UNUSED	

**Table A-2. Pin Assignments for PRI DBU Connector**

Pin	Name	Description
1	RX RING	Receive data from network
2	Rx TIP	
3	UNUSED	
4	TX RWG	Send data towards the network
5	TX TIP	
6,7,8	UNUSED	

**Table A-3. Pin Assignments for V.35 Connector**

<b>Pin</b>	<b>CCITT</b>	<b>Description</b>
A	101	Protective Ground (PG)
B	102	Signal Ground (SG)
C	105	Request to Send (RTS)
D	106	Clear to Send (CTS)
E	107	Data Set Ready (DSR)
F	109	Received Line Signal Detector
H	-	Data Terminal Ready (DTR)
J	-	Ring Indicator (RI)
L	-	Local Loopback (LL)
N	-	Remote Loopback (RL)
R	104	Received Data (RD-A)
T	104	Received Data (RD-B)
V	115	Receiver Signal Element Timing (SCR-A)
X	115	Receiver Signal Element Timing (SCR-B)
P	103	Transmitted Data (SD-A)
S	103	Transmitted Data (SD-B)
Y	114	Transmitter Signal Element Timing (SCT-A)
AA	114	Transmitter Signal Element Timing (SCT-B)
U	113	External TX Signal Element (SCX-A)
W	113	External TX Signal Element (SCX-B)
NN	-	Test Indicator (TI)

**Table A-4. Pin Assignments for Control Connector**

RJ Pin#	Function	Direction
1	GND	
2	RTS	
3	TD	
4	DSR	O
5	RD	O
6	CTS*	O
7	DTR	
8	DCD	O
* Used for hardware flow control.		

**Table A-5. Pin Assignments for 10BaseT Connector (Ethernet Card)**

Pin	Name	Description
1	TD+	The positive signal for the TD differential pair. This signal contains the serial output data stream transmitted onto the network.
2	TD-	The negative signal for the TD differential pair (pins 1 and 2).
3	RD+	The positive signal for the RD differential pair. This signal contains the serial input data stream received from the network.
4, 5	N/A	not used
6	RD-	The negative signal for the RD differential pair (pins 3 and 6).
7, 8	N/A	not used

**Table A-6. Pin Assignments DTE DBU Connector**

DB25 Pin#	V.35 Pin#	Function	DTE Port Direction	DCE Port Direction
1	A	FGND		
2		TD(EIA-232)		
3		RD(EIA-232)	O	
4	C	RTS		O
5	D	CTS	O	
6	E	DSR	O	
7	B	GND		
8	F	DCD	O	
9		NEG		
10		POS		
11	AA	TC-B(V.35)	O	
12	Y	TC-A(V.35)	O	
13	V	RC-A(V.35)	O	
14	T	RD-B(V.35)	O	
15		TC(EIA-232)	O	
16	R	RD-A(V..35)	O	
17		RC		
18	S	TD-B(V.35)		O
19	P	TD-A(V.35)		O
20	H	DTR		O
21	W	ETC-B(V.35)		O
22				
23	U	ETC-A(V.35)		O
24		ETC(EIA-232)		O
25	X	RC-B(V.35)	O	

## Appendix B Specifications Summary

---

### **SPECIFICATIONS AND FEATURES**

This appendix provides the standard specifications and features of the TSU IQ Rackmount.

#### **Operating Modes**

FT1/T1 frame relay

#### **Line Interfaces**

- RJ-48C, 4-wire
- Time derived from frame relay network
- Framing: SF/ESF with auto detection
- ESF Format: AT&T 54016, ANSI T1.403
- Line Coding: AMI/B8ZS
- Input signal: 0 to -36 dB
- DS0 assignment: Contiguous or alternate DTE interfaces

#### **DTE Interfaces**

- V.35 Winchester: M block female
- 56k or 64k synchronous DTE rates: 56 to 1.536, Nx56, or Nx64 kbps (N=1 to 24)
- Control: EIA-232, 8-pin modular connector (DB-25 adapter provided)

#### **DBU Interfaces**

PRI DBU Card: RJ-48C, 4-wire

**DTE DBU Card**

- EIA-232: DB-25 female DTE emulation
- V.35: V.35 Winchester male or female via optional adapter cable (part numbers: male 1200193L1; female 1200194L1).

**Diagnostics**

- Network CSU loopbacks
- Ping tests

**SNMP**

- Embedded SNMP and TELNET in-band access through shared or dedicated PVC
- Integrated SLIP/PPP (async) port
- Optional 10BaseT interface
- RFC 1213 MIB II, RFC 1315 and 1406 compliant
- ADTRAN enterprise MIB for frame monitoring and TSU control

**Agency Approvals**

- FCC Part 15, Class A
- FCC Part 68
- Industry Canada CS03
- UL and CUL



### **Relevant Protocol Standards**

- Frame Relay
  - ANSI T1.606
  - ANSI T1.607
  - ANSI T1.617
  - ANSI T1.618
  - ITU Q.922
  - ITU Q.933
  - Frame Relay Forum FRF 1.1 and 3.1
  - RFC 1490
- SNMP MIB
  - RFC 1055
- SNMP MIB
  - RFC 1315
  - RFC 1213
  - RFC 1406

### **Physical**

- Operating temperature: 0 to 50° C (32 to 122° F)
- Storage: -20 to 70° C (-4 to 158° F)
- Relative humidity: Up to 95%, non-condensing



## Appendix c Acronyms and Abbreviations

---

ACK.....	acknowledgment
AIS.....	alarm indication signal
ALM.....	alarm
ANSI.....	American National Standards Institute
AR.....	access rate
ARP.....	address resolution protocol
ASCII.....	American National Standards Code for Information Interchange
async.....	asynchronous
BECN.....	backward explicit congestion notification
BES.....	bursty errored seconds
BOP.....	bit oriented protocol
bps.....	bits per second
BPV.....	bipolar violation
CCITT.....	Consultive Committee for International Telephony and Telegraphy
CD.....	carrier detect
CIR.....	committed information rate
CO.....	central office
CPE.....	customer premise equipment
CR, C/R.....	command response
CRC.....	cyclic redundancy check
CS.....	clear to send
CSU.....	channel service unit
CTS.....	clear to send
CV.....	code violation
dB.....	decibel
DBU.....	dial backup
DCD.....	data carrier detect
DCE.....	data communications equipment
DDS.....	digital data service
DE.....	discard eligible
DLCI.....	data link connection identifier

DS0 .....	digital signal level zero
DSAP .....	destination service access point
DSR .....	data set ready
DSU .....	data service unit
DTE .....	data terminal equipment
DTR .....	data terminal ready
EA .....	extended address
EBCDIC .....	extended binary coded decimal interexchange code
EER .....	excess error rate
ESF .....	extended superframe
FCS .....	frame check sequence
FDL .....	facility data link
FECN .....	forward explicit congestion notification
FEP .....	front end processor
FIFO .....	first in first out
FR .....	frame relay
FRAD .....	frame relay access device
FRF .....	frame relay forum
FSU .....	frame relay service unit
FT1 .....	fractional T1
GUI .....	graphical user interface
HDLC .....	high-speed data link control
IA .....	inactive
IP .....	internet protocol
ISDN .....	integrated services digital network
ITU .....	International Telecommunications Union
IXC .....	interexchange carrier
KA .....	keep alive
kbps .....	kilobits per second
LAN .....	local area network
LBO .....	line buildout
LEC .....	local exchange carrier
LED .....	light emitting diode
LI .....	link integrity
LLC .....	logical link control
LOS .....	loss of signal
LMI .....	local management interface
LRC .....	lateral redundancy check
MIB .....	management information base
ms .....	millisecond
NI .....	network interface
OCU .....	office channel unit

---

OOS .....	out of service
POP .....	point-of-presence
PPP .....	point-to-point protocol
PRI .....	Primary Rate ISDN
PRM.....	performance report message
PU .....	physical unit
PVC .....	permanent virtual circuit
RD .....	receive data
RDL .....	remote digital loopback
RFC.....	request for comments
RFECN .....	remote forward explicit congestion notification
RIP .....	routing information protocol
RMA .....	return material authorization
RNR.....	receiver not ready
RR .....	receiver ready
RS.....	request to send; also recommended standard
RTS .....	request to send
Rx.....	receive
SAP .....	service access point
SDLC .....	synchronous data link control
SES.....	severely errored seconds
SF .....	superframe
SLIP .....	serial line internet protocol
SNA .....	systems network architecture
SNMP .....	simple network management protocol
SR.....	data set ready
SVC.....	switched virtual circuit
SW56 .....	switched 56
sync .....	synchronous
TD .....	transmit data
telco .....	telephone company
TR .....	data terminal ready
Tx.....	transmit
UA .....	unavailable
UAS .....	unavailable seconds
UNI.....	user-to-network interface
VRC .....	vertical redundancy check
WAN .....	wide area network



## Appendix D      Glossary

---

### ***AIS***

alarm indication signal. A signal transmitted instead of the normal signal to maintain continuity of transmission. The AIS indicates to the far end the existence and direction of the transmission fault on the line

### ***ANSI***

American National Standards Institute. Devices and proposes recommendations for international communications standards.

### ***ASCII***

American National Standard Code for Information Interchange. The standard and predominant 7-bit (8-bit with parity) character code used for data communications and data processing.

### ***asynchronous***

A method of data transmission which allows characters to be sent at irregular intervals by preceding each character with a start bit, followed by a stop bit.

### ***attenuation***

The loss of signal amplitude during transmission. The received signal is lower in signal amplitude than the transmitted signal due to losses in the transmission medium (resistance in the cable). Attenuation is measured in decibels.

### ***B8ZS***

A method of ensuring the ones density requirements in the data flow (12.5% must be ones) are met by replacing eight zero bits with a code containing intentional bipolar violations (BPVs).

### ***bandwidth***

The bandwidth determines the rate at which information can be sent through a channel (the greater the bandwidth, the more information that can be sent in a given amount of time).

***BECN***

backward explicit congestion notification. A bit set by a frame relay network to notify an interface device (DTE) that congestion avoidance procedures should be initiated by the sending device.

***BES***

bursty errored second. A second in which between 2 and 319 CVs (code violations) occurred.

***bipolar***

The predominant signalling method used for digital transmission services, such as DDS and T1. In this method, the signal carrying the binary value successively alternates between positive and negative. Zero and one values are presented by the signal amplitude at either polarity (no-value spaces are at zero amplitude).

***bipolar violation***

See BPV.

***bit***

A binary digit. A signal, wave, or state is represented as either a binary 0 or 1.

***bits per second (bps)***

The number of bits passing a specific point per second. Examples of common rates are:

- A Kilobit is one thousand bits per second (kbps)
- A Megabit is one million bits per second (Mbps)

T1 operates at 1.544 Mbps per second.

***BPV***

bipolar violation. A violation in the alternate mark inversion line code for which consecutive 1s are represented by pulses of opposite polarity. Bipolar violations that are not intentional (B8ZS) are counted as errors. Could also be the presence of two consecutive 1 bits of the same polarity on the T-carrier line.



**bridge**

A device that supports LAN-to-LAN communications. Bridges may be equipped to provide frame relay support to the LAN devices they serve. A frame relay capable bridge encapsulates LAN frames in frame relay frames and feeds them to a frame relay switch for transmission across the network. A frame relay capable bridge also receives frame relay frames from the network, strips the frame relay frame off each LAN frame, and passes the LAN frame on to the end device. Bridges are generally used to connect LAN segments to other LAN segments or to a WAN. They route traffic on the level 2 LAN protocol (e.g. the Media Access Control address), which occupies the lower sub-layer of the LAN OSI data link layer. See also router.

**bursty errored second**

See BES.

**byte**

Generally, an 8-bit quantity of information, used mainly in referring to parallel data transfer, semiconductor capacity, and data storage. Also, it is generally referred to in data communications as an octet or character.

**carrier**

The provider of the T1 service to the customer site. Carriers can be local telephone companies, regional telephone companies or any inter-exchange carrier such as AT&T, Sprint, or MCI.

**CD**

carrier detect. A signal generated by a modem or DSU/CSU. CD indicates the presence of a carrier signal on a communications link.

**channel bank**

Equipment in a telephone central office or customer premises that performs multiplexing of lower speed digital channels into a higher speed composite channel. The channel bank also detects and transmits signalling information for each channel; thereby transmitting framing information so that time slots allocated to each channel can be identified by the receiver.

**CIR**

committed information rate. Less than or equal to the access rate, the CIR is used by the service provider for rate enforcement when the network is congested. When rates exceed the CIR, frames may be discarded.

***clocking***

An oscillator-generated signal that provides a timing reference for a transmission link. A clock provides signals used in a transmission system to control the timing of certain functions. The clock has two functions: (1) to generate periodic signals for synchronization and (2) to provide a time base.

***code violation***

See CV.

***control port***

The electrical interface between the TSU IQ Rackmount unit and a control terminal. The control terminal is used to communicate commands to the unit.

***CPE***

customer premise equipment. All telecommunications terminal equipment located on the customer premises including telephone sets, private branch exchanges (PBXs), data terminals, and customer-owned coin-operated telephones.

***C/R bit***

In the Q.921 protocols, a bit that identifies a data-link-layer frame as either a command or a response.

***CRC***

cyclic redundancy check. A computational means to ensure the accuracy of frames transmitted between devices in a frame relay network. The mathematical function is computed, before the frame is transmitted, at the originating device. Its numerical value is computed based on the content of the frame. This value is compared with a recomputed value of the function at the destination device.

***CS***

See CTS.

**CSU**

channel service unit. A device used to connect a digital phone line (T1 or Switched 56 line) coming in from the phone company to either a multiplexer, channel bank, or directly to another device producing a digital signal (for example: a digital PBX, a PC, or data communications device). A CSU performs certain line-conditioning and equalization functions and responds to loopback commands sent from the central office. A CSU regenerates digital signals. It monitors them for problems, and provides a way of testing the digital circuit.

**CTS**

clear to send. A signal on the DTE interface indicating that the DCE is clear to send data.

**CV**

code violation. Cyclic redundancy check (CRC) errors and frame bit errors when in ESF (extended super frame) format, or bipolar violations and frame bit errors when in SF (super frame) format.

**data link**

See FDL.

**dB**

The standard abbreviation for decibel. A decibel is a unit of measure for signal. A decibel is usually the relation between a transmitted signal and a standard signal source. Therefore, 6 dB of loss would mean that there is a 6 dB difference between what arrives down a communications circuit and what was transmitted by a standard signal generator.

**DCE**

data communications equipment. A device that provides all the functions required for connection to telephone company lines and for converting signals between telephone lines and DTE. Also see DTE.

**DDS**

digital data service. AT&T private line service for transmitting data over a digital system. The digital transmission system transmits electrical signals directly, instead of translating the signals into tone of varied frequencies as with traditional analog transmission systems. Digital techniques provide more efficient use of transmission facilities, resulting in lower error rates and costs than analog systems.

**DE**

discard eligibility. A user-set bit indicating that a frame may be discarded in preference to other frames if congestion occurs, to maintain the committed quality of service within the network. Frames with the DE bit set are considered Be excess data.

**DLCI**

data link connection identifier. A unique number assigned to a PVC endpoint in a frame relay network. Identifies a particular PVC endpoint within a user's access channel in a frame relay network and has local significance only to that channel.

**DSU**

data service unit. A device designed to transmit and receive digital data on digital transmission facilities.

**DSR**

data set ready. A signal on the DTE interface that indicates if the communications is connected and ready to start handshaking control signals so communications can begin.

**DTE**

data terminal equipment. The end-user terminal or computer that plugs into the termination point (DCE) of a communications circuit. The main difference between the DCE and the DTE is that pins two and three are reversed.

**EER**

excess error rate. The number of code violations (CVs) are counted to determine a current error rate. If this rate exceeds a threshold set by the user, the line is said to be in an excess error rate (EER) condition or state.

**encapsulation**

A process by which an interface device places an end device's protocol-specific frames inside a frame relay frame. The network accepts only frames formatted specifically for frame relay; therefore interface devices acting as interfaces to a frame relay network must perform encapsulation. See also interface device and frame-relay-capable interface device.

**end device**

The ultimate source or destination of data flowing through a frame relay network sometimes referred to as DTE. As a source device, it sends data to an interface device for encapsulation in a frame relay frame. As a destination device, it receives de-encapsulated data (i.e., the frame relay frame is stripped off, leaving only the user's data) from the interface device.

**ESF**

extended superframe. A framing format which consists of 192-bit frames grouped into 24-frame superframes where 12 of the 24 framing bits are used as an out-of-band communications channel. Of these twelve bits, six are used for frame synchronization and six are used for a cyclic redundancy check (CRC). This method greatly increases performance monitoring capability and enables remote performance monitoring not available in superframe (SF).

**far end**

The unit or units not on-site (at the customer's premises or the other end of the T1 link).

**FCS**

frame check sequence. The standard 16-bit cyclic redundancy check used for HDLC and frame relay frames. The FCS detects bit errors occurring in the bits of the frame between the opening flag and the FCS, and is only effective in detecting errors in frames no larger than 4096 octets. See also CRC.

**FDL**

facility data link. A 4 kbps data channel provided by 12 of the ESF framing bits. The FDL can be used by both the carrier and the TSU IQ Rackmount unit for communication purposes. The TSU IQ Rackmount unit uses the FDL for report requests, clearing error counters, and activation of the loopbacks.

**FECN**

forward explicit congestion notification. A bit set by a frame relay network to notify an interface device (DTE) that congestion avoidance procedures should be initiated by the receiving device. See also BECN.

**file server**

In the context of frame relay network supporting LAN-to-LAN communications, a device connecting a series of workstations within a given LAN. The device performs error recovery and flow control functions as well as end-to-end acknowledgment of data during data transfer, thereby significantly reducing overhead within the frame relay network.

***frame-relay-capable interface device***

A communications device that performs encapsulation. Frame-relay-capable routers and bridges are examples of interface devices used to interface the customer's equipment to frame relay network. See also interface device and encapsulation.

***frame relay frame***

A variable-length unit of data, in frame-relay format that is transmitted through a frame relay network as pure data. Contrast with packet.

***frame relay network***

A telecommunications network based on frame relay technology. Data is multiplexed. Contrast with packet switching network.

***framing***

A control procedure used with multiplexed digital channels (such as T1 carriers) where bits are inserted so the receiver can identify time slots allocated to each subchannel. Framing bits may also carry alarm signals indicating specific alarm conditions, cyclic redundancy checks (CRCs), and an out-of-band data channel in the case of an extended superframe (ESF) T1 link. In T1 terminology, a frame consists of 192 data bits and one framing bit.

***gateway***

A device which enables information to be exchanged between two dissimilar systems or networks.

***HDLC***

high level data link control. A generic link-level communications protocol developed by the International Organization for Standardization (ISO). HDLC manages synchronous code-transparent, serial information transfer over a link connection. See also SDLC.

***host computer***

The primary or controlling computer in a multiple computer operation.

***in-band***

Signaling (dialing, diagnostics, management, configuration, etc.) over the same channel used for data.

***ingress***

Frame relay frames leaving from an access device in a direction toward the frame relay network.

***interface device***

Provides the interface between the end device(s) and a frame relay network by encapsulating the user's native protocol in frame relay frames and sending the frames across the frame relay backbone. See also encapsulation and frame-relay-capable interface device.

***IP***

internet protocol. A protocol which provides for transmitting blocks of data between hosts identified by fixed-length addresses.

***ISDN***

integrated services digital network. A network architecture that enables end-to-end digital connections. The network supports diverse services through integrated access arrangements and defines a limited set of standard, multi-purpose interfaces for equipment vendors, network providers, and customers. Interworking with a public switched telephone network is retained.

***LAN***

local area network. A privately owned network that offers high-speed communications channels to connect information processing equipment in a limited geographic area.

***LBO***

line buildout. The introduction of gain or loss in a signal to optimize the signal level for a receiver.

***local loop***

In telephony, the wire pair that connects a subscriber to a phone company end office. Four-wire local loops are common and are used on T1 facilities.

***local loopback***

A type of test used to verify the operation of the local terminal equipment, the CSU, and the connection between the two units. The signal from the DTE is looped back by the CSU and is sent back to the DTE.

***loopback***

The technique for testing the processing circuitry of a communications device. May be initiated locally or remotely via a telecommunications circuit. Device being tested will echo back received test data. The results are compared with the original data.

**LOS**

loss of signal. Defined as a line state in which no pulses are received for 175 bit positions.

**MIB**

management information base. A database of network management information used by SNMP.

**modem**

The equipment that connects DTE to an analog (voice) communications.

**near end**

The unit on-site.

**network interface (NI)**

The point of interconnection between the TSU IQ Rackmount unit and the carrier's T1 network.

**out-of-band**

Signaling that is separated from the channel carrying information (voice, data, video, etc.). Typically the separation is accomplished by a filter. The signaling includes dialing and other supervisory signals.

**packet**

A message containing both control information and data. The control information is used for routing the packet through a network to its final destination. Contrast with frame relay frame.

**packet-switching network**

A telecommunications network based on packet-switching technology, wherein a transmission channel is occupied only for the duration of the transmission of the packet. Contrast with frame relay network.

**parameter**

A numerical code that controls an aspect of terminal and/or network operation. Parameters control such aspects as page size, data transmission speed, and timing options.

**PRM**

performance report message. A message sent to the network interface (NI) once per second over the FDL which contains performance monitoring and status information. This is available in ESF only.



***ping***

An internet protocol standard that provides loopback on demand for any device in an IP network. One device "pings" another by sending a loopback request to the device's IP address.

***point-to-point***

Type of communications link that connects a single device to another single device, such as a remote terminal to a host computer.

***PVC***

permanent virtual circuit. A frame relay logical link, whose endpoints and class of service are defined by network management. Analogous to an X.25 permanent virtual circuit, a PVC consists of the originating frame relay network element address, originating data link control identifier, terminating frame relay network element address, and termination data link control identifier. Originating refers to the access interface from which the PVC is initiated. Terminating refers to the access interface at which the PVC stops. Many data network customers require a PVC between two points. Data terminating equipment with a need for continuous communion use PVCs. See also DLCI.

***red alarm***

A red alarm is declared on detection of an LOS or OOF not caused by an alarm indication signal (AIS) that persists for two seconds.

***remote configuration***

A feature designed into ADTRAN products that allows remote units to be configured from a local unit or VT 100 compatible terminal.

***router***

A device that supports LAN-to-LAN communications. Routers may be equipped to provide frame relay support to the LAN devices they serve. A frame-relay-capable router encapsulates LAN frames into frame relay frames and feeds those frame relay frames to a frame relay switch for transmission across the network. A frame-relay-capable router also receives frame relay frames from the network, strips the frame relay frame off of each frame to produce the original LAN frame, and passes the LAN frame on to the end device. Routers connect multiple LAN segments to each other or to a WAN. Routers route traffic on the Level 3 LAN protocol (e.g., the internet protocol address). See also bridge.

***SDLC***

synchronous data link control. A link-level communications protocol used in an IBM systems network architecture (SNA) network that manages synchronous, code-transparent, serial information transfer over a link connection. SDLC is a subset of the HDLC protocol developed by ISO.

***service***

The provision of telecommunications to customers by a common carrier, administration, or private operating agency using voice, data, and/or video technologies.

***SES***

severely errored second. A second in which more than 319 code violations (CVs) occurred or an OOF condition occurred.

***SF***

See superframe.

***SNA***

systems network architecture. The IBM protocol group which governs main-frame communication.

***SNMP***

simple network management protocol. A control and reporting scheme widely used to manage devices from different vendors. SNMP operates on top of the internet protocol.

***statistical multiplexing***

Interleaving the data input of two or more devices on a single channel or access line for transmission through a frame relay network. Interleaving of data is accomplished using the DLCI.

***superframe (SF)***

A T1 framing format in which 192-bit frames are grouped into 12 frame superframes and all 12 framing bits are used for all frame synchronization.

***switched network***

The network of dial-up telephone lines using circuit switching to provide communications services to network users.

***synchronizing bits (sync bits)***

A fixed pattern in synchronous transmission used to identify the boundaries of frames.

***synchronous***

Communications in which the timing is achieved by sharing a single clock. Each end of the transmission synchronizes itself with the use of clocks and information sent along with the transmitted data.

***T1***

A digital transmission link with a capacity of 1.544 Mbps. T1 uses two pairs of normal twisted wires. T1 normally can handle 24 voice conversations with each conversation being digitized at 64 kbps. With more advanced digital voice encoding techniques, it can handle more voice channels. T1 is a standard for digital transmission in North America. It is also called T-1.

***TELNET***

The standard TCP/IP remote login protocol specified in RFC-854.

***transmission***

The dispatching of a signal, message, or other form of intelligence by wire, radio, telegraphy, telephony, facsimile, or other means. A series of characters, messages, or blocks including control information and user data. The signaling of data over communications channels.

***T-span***

A telephone circuit or cable through which a T1 carrier line runs.

***UAS***

unavailable seconds. An unavailable second (UAS) state is declared at the onset of ten consecutive severely errored seconds (SES). The UAS state is cleared at the onset of ten consecutive seconds with no SES.

***VT-100***

A non-intelligent terminal or terminal emulation mode used for asynchronous communications. Used to configure the TSU IQ Rackmount.

***yellow alarm***

When the local CSU is in a red alarm condition, it sends a bit pattern (in-band in SF, out-of-band in ESF) towards the network to tell the carrier and the far-end CSU that there is a problem in the receive direction.



# Index

---

## Numerics

- 10BaseT connector, pinouts A-3
- 10BaseT ethernet, LAN interface, 2-5

## A

- affidavit
  - connection for digital services, vii
  - connection of CPE equipment, v
- agency approvals, specifications, B-2
- agent, used with SNMP, 1-6
- alarm
  - frame relay alarm, 3-3
  - on front panel, 3-3
  - red alarm, 3-3
  - T1 alarm conditions, 3-3
- automatic dial backup, 8-3

## C

- call manager statistics
  - for PRI dial backup, 10-24
- Canadian emissions requirements, viii
- Canadian equipment limitations, ix
- Configuration overview, local and remote, 5-1
- configuration, for DTE port, 6-1
- configuration, menu tree, 5-1
- control connector, pinouts, A-3
- control port, 3-2
- customer service, x

## D

- DBU application example, PRI, 4-15
- DBU application, non-PRI, 4-13
- DBU criteria, list of, 8-4
- DBU interfaces, specifications, B-1
- DBU operation, 1-6
- DBU port statistics, 10-19
- DBU timers, list of, 8-4
- DCE Option card, description 8-7

- dedicated PVC management
  - configuration requirements, 4-11
- dedicated PVC management, 4-10
- diagnostics
  - ping test, 11-1
  - PVC loopback test, 11-2
  - specifications, B-2
- dial backup
  - Auto DBU, 8-3
  - menu tree, 8-2
- dial backup application
  - general information, 4-11
  - non-PRI, 4-13
  - PRI, 4-15
- dial backup card configuration
  - for DCE options, 8-7
  - for PRI options 8-5
- dial backup operation, 1-6
- dial backup options
  - list of all options, 8-3
- dial options
  - during dial backup 12-2
  - when dial backup is idle 12-2
- dialing options, 12-1
- DLCI statistics
  - for a specific DLCI, 10-25
- DLCI, View statistics list 10-30
- DLCL statistics
  - from network statistics menu, 10-25
- DTE connectors, on rear interface card, 2-2
- DTE DBU Card
  - specifications, B-2
- DTE DBU connector, pinouts, A-4
- DTE DBU, interface connector, 2-5
- DTE Interfaces, specifications, B-1
- DTE port
  - configuration, 6-1
  - frame relay menu descriptions, 6-4

- menu tree, 6-2
- physical layer menu descriptions, 6-2

DTE port statistics, 10-4**E**

ethernet card, pinouts, A-3

**F**

- FCC regulations, iv
- Features, of TSU IQ RM, 1-2
- fractional T1, general description, 1-5
- frame relay options, network port config, 7-4
- frame relay signaling, list of, B-3
- frame relay, alarm conditions, 3-3
- frame relay, general description, 1-3
- front panel, description, 3-1

**H**

- historical data statistics
  - how to calculate, 9-5
- history intervals
  - storing statistical information, 7-6
- hot keys, for statistics menus 10-3

**I**

- in and out test jacks, 2-4
- in-band management, for frame relay, 4-5
- installation of unit, how to, 2-1
- interface card options, 1-7

**L**

- LAN interface connector, 2-5
- Layer 3 statistics, 10-14
- LEDs, (front panel) description, 3-2
- line interfaces
  - specifications, B-1
- Local PVC Management
  - configuration requirements, 4-7
- local PVC management, 4-6

**M**

- main menus, general descriptions, 3-8
- management applications
  - for configuration and diagnostics, 4-1
- management DLCI
  - using local PVC management, 6-5
- menu tree
  - dial options - non-PRI DBU, 12-1
  - dial options - PRI DBU, 12-1
  - for dial backup, 8-2
- MIB, used with SNMP, 1-6

monitor test jack, 2-4

**N**

- network connector, pinouts A-1
- network interface connector, 2-4
- network manager, used with SNMP 1-5
- network port
  - description of, 7-1
  - management DLCI 1 and 2, 7-5
  - physical layer options, 7-2
- network port config, frame relay options, 7-4
- network port statistics, 10-8

**O**

- operating modes
  - specifications, B-1
- operation, of front panel, 3-1

**P**

- Ping, test, 11-1
- pinouts
  - 10BaseT connector, A-3
  - control connector, A-3
  - DTE DBU connector, A-4
  - ethernet card, A-3
  - network connector, A-1
  - PRI DBU connector, A-1
  - V.35 connector, A-2
- plug on card
  - DCE DBU, 1-7
  - PRI DBU, 1-7
- power up and initialization, 2-5
- PRI DBU application example, 4-15
- PRI DBU connector, pinouts, A-1
- PRI DBU Interface, 2-4
- PRI Option card, description 8-5
- product overview, 1-1
- product warranty, xi
- protocol standards, list of, B-3
- PVC count
  - monitoring statistical information, 7-6
- PVC loopback, test, 11-2
- PVC management
  - dedicated, 4-10
  - local, 4-6
  - shared 4-8
- PVC options, for network port, 7-6
- PVC signaling formats, 7-1

**R**

- rear interface card, description of, 2-2

receipt inspection, 2-1  
repair information, x  
resetting monitoring data, 10-1  
return material authorization (RMA), x  
returning defective equipment, x

## S

safety information, x  
Shared PVC Management  
    configuration requirements, 4-9  
shared PVC management, 4-8  
Smart 16/Smart 16e Controller Card, 3-3  
Smart16 Controller Access, menu definitions, 3-5  
SNMP management, about, 1-5  
SNMP, specifications, B-2  
SNMP/Telnet access  
    configuration requirements, 4-4  
specifications  
    for storage temperature B-3  
specifications, B-1  
statistical history storage, 7-6  
statistical information, viewing from main menu, 10-1  
statistics  
    call manager, 10-24  
    DBU port statistics, 10-19  
    display options, 10-2  
    DLCI, 10-25  
    for protocols 1 & 2, 9-4  
    historical data, 9-5  
    how to reset data, 10-1  
    network port, 10-8  
    top talkers, 10-17  
    viewing information, 10-1  
system configuration  
    description of menu items, 9-1  
systems statistics  
    for system time and date, 10-31

## T

T1 alarm conditions, 3-3  
T1 service offering, description of, 1-4  
T1/FT1 overview, general information, 1-4  
Telnet, description, 1-6  
test  
    PVC loopback, 11-2  
Test Jacks  
    In/Out, 2-4  
    monitor, 2-4  
testing, diagnostic, 11-1  
time and date statistics, 10-31  
top talkers statistics, 10-17  
trademark, information ii  
TSU IQ Rackmount menu structure, 3-8

## U

unit installation  
    items provided by customer, 2-2  
unit installation,  
    items provided by Adtran, 2-2

## V

V.35 connector, pinouts A-2  
V.35, DTE data Connection, 2-5  
view by day, statistics information, 10-2  
view by interval, statistics display option, 10-2  
VT-100  
    Terminal Management, 4-1  
VT-100 management  
    configuration requirements, 4-2  
VT-100 terminal  
    connection and operation, 3-6

## W

warranty, x





## Product Support Information

### Pre-Sales Inquiries and Applications Support

Please contact your local distributor, ADTRAN Applications Engineering, or ADTRAN Sales:

Applications Engineering      (800) 615-1176

Sales      (800) 827-0807

### Post-Sale Support

Please contact your local distributor first. If your local distributor cannot help, please contact ADTRAN Technical Support and have the unit serial number available.

Technical Support      (888) 4ADTRAN

### Repair and Return

If ADTRAN Technical Support determines that a repair is needed, Technical Support will coordinate with the Customer and Product Service (CaPS) department to issue an RMA number. For information regarding equipment currently in house or possible fees associated with repair, contact CaPS directly at the following number:

CaPS Department      (256) 963-8722

Identify the RMA number clearly on the package (below address), and return to the following address:

ADTRAN, Inc.  
CaPS Department  
6767 Old Madison Pike  
Progress Center  
Building #6, Suite 690  
Huntsville, AL 35807

RMA # \_\_\_\_\_