

**ACCESS
CONTROL
DOOR PHONES**

Installation and
Programming Manual
for
PanCam-C
PanCam-T
Pantel
Pancode

**PanCam-C
PanCam-T
Pantel
Pancode**

Installation and Programming Manual

Release 3, May 2003

NOTICE

This manual describes the PanCam/Pantel/Pancode Access Control Door Phones system.

The hardware and software described in the manual can be changed without prior notice. However, changes made to the hardware or software described does not necessarily render this publication invalid.

Table of Contents

1	Introduction	1
1.1	PanCam.....	1
1.2	Pantel	4
1.3	Pancode.....	6
2	Installation	9
2.1	Installation Instructions.....	9
2.2	Adjacent Access Control Device	12
2.3	Connection Schematic	14
2.4	Volume Control	14
3	Programming.....	15
3.1	Day/Night Mode Selection	15
3.2	Entering Programming Mode	15
3.3	Resetting the PanCam/Pantel/Pancode	16
3.4	PanCam-T/Pantel Setup and Operation	16
3.5	PanCam-C/Pancode Setup	18
3.6	Entering Special DTMF Characters.....	23
4	Specifications	25
4.1	General Specifications	25
4.2	Camera Specifications	26
5	Comparison Table.....	29

1 Introduction

We offer a wide range of Access Control Door Phones for indoor and outdoor entry control. These solutions range from the simplest one button unit to the most sophisticated unit with a keypad and built-in camera to monitor visitors at the entrance. All of the Access Control Door Phones incorporate cutting edge technology, providing a high quality speakerphone and a built-in electromagnetic lock controller. All the Access Control Door Phones are easy to set-up, modern and durable in design and provide “plug and play” installation.

This guide provides installation and programming instructions for the following products:

- PanCam unit
- Pantel Outdoor unit
- Pantel Indoor unit
- Pancode Outdoor unit
- Pancode Indoor unit

1.1 PanCam

The PanCam unit is available in two versions: PanCam-C (with keypad) and PanCam-T (one button). Both are wall mounted access control door phones, connected to an analog port of a PBX or a Key Telephone System, with an internal black & white or color high-quality pinhole camera encased within the unit. Both, PanCam-C and T are vandal and weather resistant, suitable for outdoor installation.

General Features

The PanCam controls the camera, providing three different modes of operation:

- Always on
- Powered by pressing any button
- Powered by pressing the call button

Calling the PanCam unit from any extension will activate its camera, enabling the door supervisor to see who is in the direct neighbourhood of the unit.

PanCam-C Features

The PanCam-C unit has the following features:

- Direct dialing to any extension
- Speed-dial to internal or external subscribers
- Automatic Busy & Disconnect Cadence Detection

Introduction

- Door opening from any extension
- Programmable day and night destinations
- Two different operation modes, standard/speed-dial
- High quality speaker phone with volume control
- Entry access code
- Works in conjunction with card readers and security devices
- Simple to operate and program
- Smart looking durable design
- Internal black & white or color high-quality pinhole camera

PanCam-T Features

The PanCam-T unit has the following features:

- Dialing to a pre-defined extension/subscriber
- Door opening from any extension
- Programmable day and night destinations
- Automatic Busy & Disconnect Cadence Detection
- Designed for wall mounting
- Works in conjunction with card readers and security devices
- High quality speaker phone with volume control
- Simple to operate and program
- Internal black & white or color high-quality pinhole camera

PanCam Physical Description

The following figure describes both units.

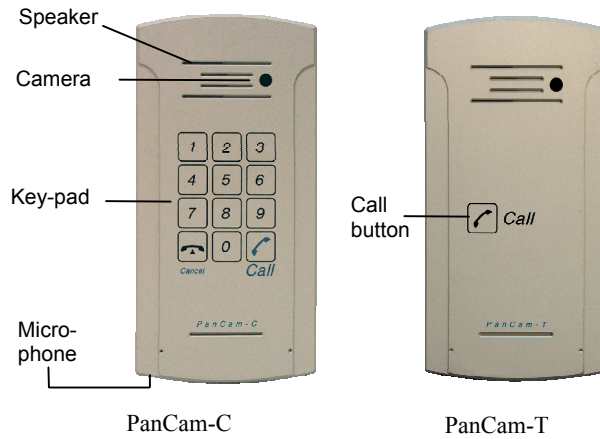

Figure 2-1. PanCam Front Panel

The front panel of the PanCam-T unit incorporates a speaker and a Call button. The microphone can be found at the bottom of the unit. The PanCam-C unit also features a keypad. The front panel is attached to the wall using a bracket and screws. The PanCam units are hardwired units, powered by an external 12V AC transformer, included in the package. Optionally, you may use a 12-24V DC adapter.

1.2 Pantel

The Pantel is a wall mounted access control door phone, which is connected to an analog port of a PBX or a Key Telephone System. The Pantel is compatible with most known telephone systems and PBX types.

With the press of a button, the Pantel dials a pre-defined extension number of up to 20 digits, allowing a conversation to take place and then enables the dialed party to open the door for the caller by pressing touch tone digit(s).

The Pantel is available in either an aluminum unit for outdoor installation, which is weather and vandal resistant, or a plastic unit for indoor installation.

Features

The outdoor and indoor Pantel units have the following features:

- Dialing to a pre-defined extension/subscriber
- Door opening from any extension
- Programmable day and night destinations
- Automatic Busy & Disconnect Cadence Detection (outdoor unit only)
- Designed for wall mounting
- Works in conjunction with card readers and security devices
- High quality speaker phone with volume control
- Simple to operate and program
- Outdoor or indoor installation

Physical Description

Figure 1-2. Pantel Front Panel

The front panel of the Pantel unit incorporates a speaker and a Call button. The microphone can be found at the bottom of the unit. The front panel is attached to the wall using a bracket and screws.

The Pantel unit is a hardwired unit powered by an external 12V AC transformer, included in the package. Optionally, you may use a 12-24V DC adapter (for outdoor unit only).

1.3 Pancode

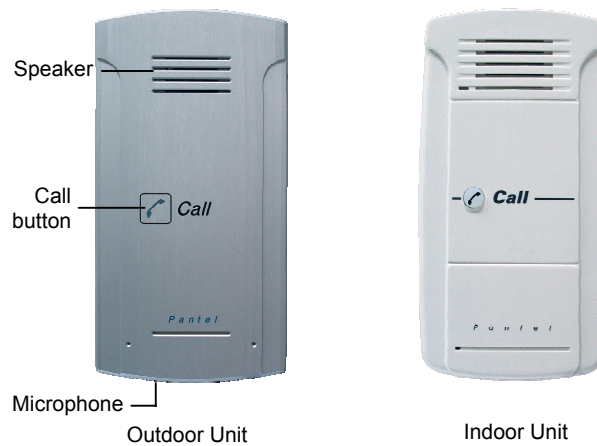
The Pancode is a smart wall mounted access control door phone that is connected to an analog port of a PBX or a Key Telephone System, allowing door entry control.

The Pancode is available in either an aluminum unit for outdoor installation, which is weather and vandal resistant, or a plastic unit for indoor installation.

Features

The outdoor and indoor Pancode units have the following features:

- Direct dialing to any extension
- Entry access code
- Speed-dial to internal or external subscribers
- Automatic Busy & Disconnect Cadence Detection (outdoor unit only)
- Door opening from any extension
- Programmable day and night destinations
- Two different operation modes, standard/speed-dial
- High quality speaker phone with volume control
- Outdoor or indoor installation
- Works in conjunction with card readers and security devices
- Simple to operate and program
- Smart looking durable design

Physical Description

Figure 1-3. Pancode Front Panel

The front panel of the Pancode unit incorporates a speaker and a keypad. The microphone can be found at the bottom of the unit. The front panel is attached to the wall using a bracket and screws.

The Pancode unit is a hardwired unit powered by an external 12V AC transformer, which is provided in the package. Optionally, you may use a 12-24V DC adapter (For outdoor unit only)

2 Installation

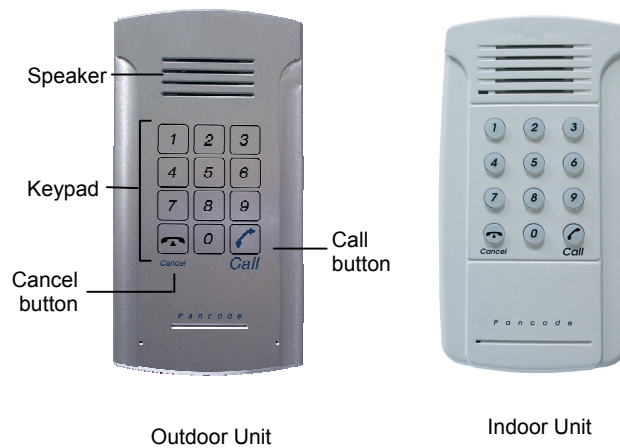
The PanCam/Pantel/Pancode is mounted to the installation bracket provided; this mounting bracket should be installed with the arms of the bracket positioned at the bottom.

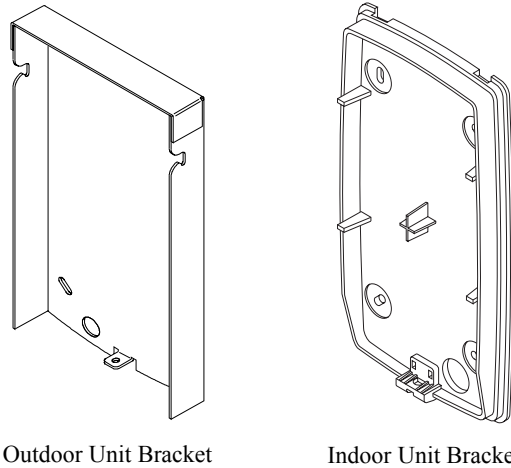

Figure 2-1. Installation brackets

To Install the PanCam/Pantel/Pancode wall bracket

1. Measure and mark the location on the wall where the holes will be drilled for the mounting bracket.
2. Drill the holes and insert the wall anchors into the holes. The wall anchors should be flush with the wall.
3. Attach the mounting bracket using the wall screws provided.

2.1 Installation Instructions

Installing the PanCam

Power (12V DC) is provided to the camera via an extended connector in the PanCam. The camera is activated, once the relevant instruction is given (e.g. push on the call button, etc.).

Caution

To avoid damage to the camera, make sure to connect the correct polarity to the connector (see Figure 2-2).

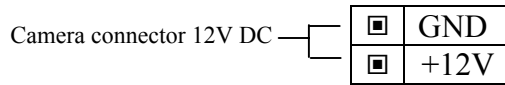

Figure 2-2. Camera connector

PanCam Schematic setup

The following pictures show the schematic setup of the PanCam unit.

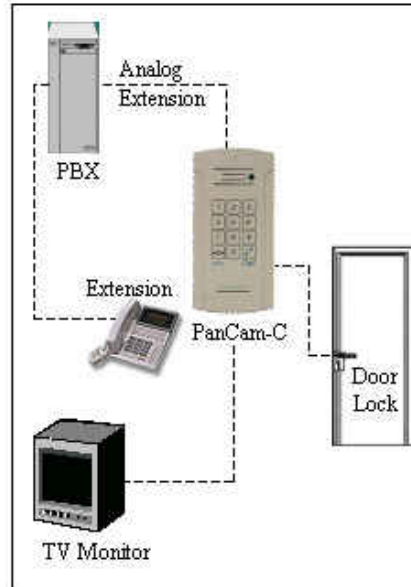

Figure 2-3. PanCam Schematic setup

The video signal is independent and connected directly to third-party video equipment (e.g. a video recorder, monitor, multiplexer, PC, etc.).

The unit is connected to the PBX as an analog extension.
The unit powers the Door Lock and the Camera.

Installing the Pantel/Pancode

The Pantel/Pancode can be installed as the individual access control or can be used with adjacent access-control devices, such as card reading devices. For more information on adjacent access-control device installation, see section 2.2, *Adjacent Access Control Device*.

A 12V AC external power supply is included with the Pantel/Pancode unit. A 12 to 24V DC/1.6A power adapter, which provides a quieter door-lock action, can also power the Pantel/Pancode. The power adapter should not be located further than 10m (30ft) from the Pantel/Pancode.

The following figure shows the terminal locations on the wire connector provided with the Pantel/Pancode. This connector is attached at the base of the internal component. All wiring to the Pantel/Pancode is attached to the wire connector.

The Pantel/Pancode supports a bypass switch installation. This allows opening the door with a hardwired switch. A bypass switch should be connect to the SW and /SW terminals.

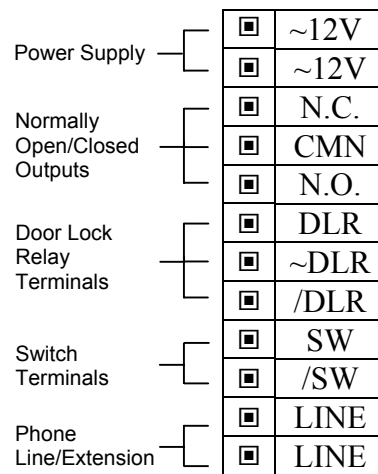

Figure 2-4. Connector Wiring

Note: For the installation of the powered-unlocked-state, use DLR and ~DLR. For the installation of the powered-locked-state, use /DLR and ~DLR (**this is recommended for safety purposes**).

Installation

The wiring connector is a screw connector type. In order to attach a wire you must insert the stripped end of the wire into the proper terminal and tighten the terminal screw. This will crimp the wire connection.

Caution

To avoid damage to the Pantel/Pancode, the power supply should be removed prior to connecting wires to the Pantel/Pancode unit.

To Install the Pantel/Pancode

1. Remove the cover from the Pantel/Pancode unit and disconnect the wire connector, found at the base of the internal component.
2. Connect the two 12V lead wires from the 12V AC power adapter (or the 12-24V DC adapter), one to each of the “~12V” terminals.
3. Connect the two PBX extension wires, one to each of the “LINE” terminals.
4. Connect the door-lock relay wires to the “DLR” and “~DLR” terminals
-or-
If the door-lock relay is a powered-locked-state type lock, connect the door-lock relay wires to the “DLR” and “~DLR” terminals.
5. If a push button switch is used, connect the push button wires to the “SW” and the “/SW” terminals.
6. Plug the wire connector to the base of the Pantel/Pancode inner component.
7. Place the Pantel/Pancode onto the mounting bracket.
8. Switch on the power to the 12V adapter.

After installation, you can now program the Pantel/Pancode unit. For details on programming, see section 3, *Programming*.

2.2 Adjacent Access Control Device

This section describes adding an access-control device to an existing Pantel/Pancode, and adding a Pantel/Pancode to an existing access-control device. The key difference between these two installations is which Access-control device controls the door lock relay.

Adding an Access Control Device to the Pantel/Pancode

When activated, the access-control triggers the Pantel/Pancode “SW” terminal, which activates the door-lock relay and opens the door.

For this type of installation, the access-control device “N.O.” output wires are connected to the Pantel/Pancode Switch terminals (see Figure 2-5.)

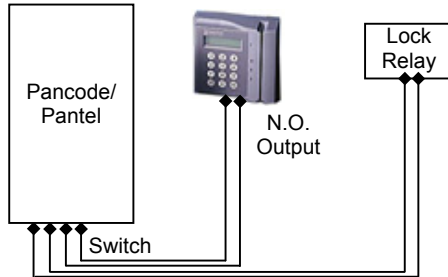

Figure 2-5. Pantel/Pancode – Controlling Lock Relay

Adding Pantel/Pancode to an Access Control Device

The access control device opens the door when the Pantel/Pancode triggers the access-control device.

For this installation, the access-control device bypass “Switch” wires are connected to the “N.O.” and “CMN” terminals of the Pantel/Pancode. The door-lock relay wires are connected to the access-control device (see Figure 2-6.)

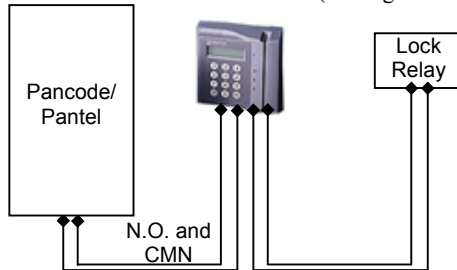

Figure 2-6. Access Control - Controlling Lock Relay

2.3 Connection Schematic

The Pantel/Pancode offers multiple wiring options.

- **Option 1:** For use with an external device, which requires the Pancode to be set up as “Normally Closed”
- **Option 2:** For use with an external device, which requires the Pancode to be set up as “Normally Open”
- **Option 3:** For use with the powered-unlocked-state lock relay (most common)
- **Option 4:** For use with the powered-locked-state lock relay
(recommended for safety purposes)

The following schematic diagram shows the wiring plan for these four options.

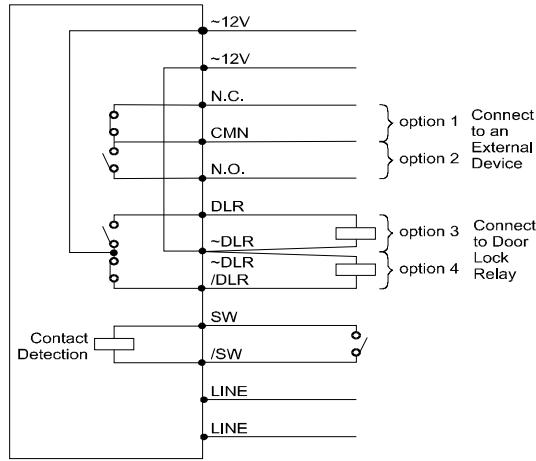

Figure 2-7. PanCam/Pantel/Pancode Wiring Schematics

2.4 Volume Control

The volume of the PanCam/Pantel/Pancode speaker can be adjusted using the volume controller located on the unit’s back panel.

After installing the unit, test the volume. In case it is too low/high, remove the unit from the mounting bracket and adjust the volume using a small screwdriver.

3 Programming

Programming can be done from any telephone or extension on the PBX, using keypad DTMF tones. The following programming functions are discussed in this section:

- Day/Night Mode Selection
- Entering Programming Mode
- Resetting the PanCam/Pantel/Pancode

3.1 Day/Night Mode Selection

Day and Night mode specify which of the programmed destination numbers, Day or Night number, will be called when the  Call button is pressed. The operator can manually change the Day/Night mode.

To Change the Day/Night Mode

1. Dial the PanCam/Pantel/Pancode line/extension from any touch-tone telephone.
2. Wait until the PanCam/Pantel/Pancode answers and beeps.
3. Enter *80 for Day Mode
-or-
enter *81 for Night Mode.

3.2 Entering Programming Mode

Note: You will hear a confirmation tone every time you enter a programming command.

To Enter Programming Mode

1. Dial the PanCam/Pantel/Pancode line/extension from any touch-tone telephone.
2. Wait until the PanCam/Pantel/Pancode answers and beeps.
3. Dial *900.
4. Enter the Programming Access Password (default password is 1234).

To Exit Programming Mode

- Dial *900
-or-
if no dialing occurs within 45 seconds, the program mode automatically exits.

3.3 Resetting the PanCam/Pantel/Pancode

Resetting the PanCam/Pantel/Pancode will automatically change the parameters in the unit to the manufacturers default.

To Reset the Unit

1. Enter programming mode (see section 3.2, *Entering Programming Mode*).
2. Dial *151.
3. A confirmation tone will be heard.
4. Exit programming mode.

To Reset the Unit in “speed dial” mode (only PanCam-C and Pancode)

1. Enter programming mode (see section 3.2, *Entering Programming Mode*).
2. Dial *152.
3. A confirmation tone will be heard.
4. Exit programming mode.

3.4 PanCam-T/Pantel Setup and Operation

The following table contains programming functions, which can be accessed in the programming mode for Setup and operation.

PBX Parameter Commands

OPERATION	COMMAND	DEFAULT
Day, Night destination numbers	*360 + X + DN + # where: X = 1; Day destination X = 2; Night destination DN = Up to 20 digits. For special character input, see section 3.6 <i>Entering Special DTMF Characters</i> .	Day = 0 Night = 0
Delete the destination assignments	*360 + X + # where: X = 1; Day destination X = 2; Night destination	

OPERATION	COMMAND	DEFAULT
*For Pantel Indoor ONLY: Busy off/on time cadence setups for disconnecting the line when the destination is busy	*371 + X + YYYY where: X = 1; off time setup X = 2; on time setup YYYY = Cadence in steps of 20 milliseconds	500 msec 500 msec
Digit(s) to open the door from any extension	*441 +XXXX + # where: XXXX = Digits (0-9) Note: Up to 4 digits	8
*For Outdoor units ONLY Time between DTMF's	*460 + X where: X = 1-9 (Each step is 200 msec)	2 (400ms)
Maximum time for the line to be opened (sec)	*462 + XX XX = Seconds (10-99) 00 = Unlimited	45 sec
Door opening time limit (sec)	*464 + X X = Seconds (1-9)	3 sec
Change the system administrator's password	*600 + New password (must be 4 digits). Warning: Do not use the * or # keys	1234
*For PanCam-T ONLY Camera instructions	*620 + X X = 0 camera off X = 1 camera on X = 2 camera powered when call button is pressed	0

3.5 PanCam-C/Pancode Setup

The PanCam-C/Pancode can work in two modes of operation: Standard and Speed-dial.

In Standard mode, which is the default, the keypad requires direct dialing of extensions and numbers.

In Speed-Dial mode, keys 1-9 can be assigned destination phone numbers. When a key is pressed, the assigned destination number is dialed.

To Set the PanCam-C/Pancode Operation Mode

1. Dial the PanCam-C/Pancode line/extension from any touch-tone telephone.
2. Wait until the PanCam-C/Pancode answers and beeps.
3. Dial *900.
4. Enter the Programming Access Password (default password is 1234.)
5. For Standard Mode, dial *151 (See 3.5.2 for programming)
-or-
for Speed-Dial Mode, dial *152 (See 3.5.3 for programming).

Note: *When selecting or changing the operation mode with *151 or *152, all previously programmed information will automatically be deleted. The unit will provide you with it's default values.*

Standard Setup

The following table contains programming functions, which can be accessed in the programming mode for Standard Setup operation.

PBX Parameter Commands

OPERATION	COMMAND	DEFAULT
The Day/Night DN will be dialed when the  Call button is pressed, respective to Day/Night mode. The Error DN is dialed after receiving three invalid Access Code entries in a row	*360 + X + DN + # where: X = 1 Day X = 2 Night X = 3 Error Destination number (DN) = Up to 20 digits, including *, #, Pause, and A-D characters. For special character input, see section 3.6 <i>Entering Special DTMF Characters</i> .	Day = 0 Night = 0 Error = No default
Delete a destination number assigned to Day, Night, or Error DNs. This command must be entered separately for each X value	*360 + X + # where: X = 1 Day X = 2 Night X = 3 Error	
Programming the prefix-digit(s) for PBX extensions dialing. When input to the PanCam-C/ Pancode begins with these digits, the PanCam-C/ Pancode will process them as extension dialing	*170 + prefix-digit(s) + # Maximum 4 digits (Do Not use * or # as prefix digit) To cancel this operation, enter: *170 + #	No default
Digit(s) to open the door from any extension	*441 +XXXX + # where: XXXX= Digits (0-9) Note: Up to 4 digits.	8

OPERATION	COMMAND	DEFAULT
Changing the Opening door Access Code	*442 + (New Access Code) Access Codes can be up to four numeric digits. If the New Access Code is less than four numeric digits, press the # following the entry of the digits. Allowable characters are 0 through 9. Do not use the * or # keys. Note: The access code cannot begin with the same prefix digits as PBX extension numbers	9876
*For Outdoor units ONLY Time between DTMF's	*460 + X where: X = 1-9 (each step is 200 msec)	2 (400)
Conversation time limit (sec)	*462 + XX where: XX = Seconds (10-99) 00 = Unlimited	45 sec
Door opening time limit (sec)	*464 + X where: X = Number of seconds (1-9)	3 sec
Changing the programming password	*600 + (new password) Programming access password must be four numeric digits. Allowable characters are 0 through 9. Do not use the * or # keys.	1234
*For PanCam-C ONLY Camera instructions	*620 + X X = 0 camera off X = 1 camera on X = 2 camera powered when call button is pressed X = 3 camera powered when any key is pressed	0

Speed-Dial Setup

The following table contains programming functions, which can be accessed in the programming mode for Speed-Dial mode operation.

PBX Parameter Commands

OPERATION	COMMAND	DEFAULT
Assigning a Speed-dial destination number. This command must be entered separately for each X value	*120 + X + DN + # X = a digit 1 through 9 DN = Destination number (DN) = Up to 20 digits, including *, #, Pause, and A-D characters. For special character input, see section 3.6 <i>Entering Special DTMF Characters</i> .	No default
Cancelling a Speed-dial destination number. This command must be entered separately for each X value	*120 + X + # X = a digit 1 through 9	No default
The Day/Night DN will be dialed when the  Call button is pressed, respective to Day/Night mode. The Error DN is dialed after receiving three invalid Access Code entries in a row	*360 + X + DN + # where: X = 1 Day X = 2 Night X = 3 Error Destination number (DN) = Up to 20 digits, including *, #, Pause, and A-D characters. For special character input, see section 3.6 <i>Entering Special DTMF Characters</i> .	Day = 0 Night = 0 Error = No default

OPERATION	COMMAND	DEFAULT
Delete a destination number assigned to Day, Night, or Error DNs. This command must be entered separately for each X value	*360 + X + # where: X = 1 Day X = 2 Night X = 3 Error	
Defining the digit(s) to open the door from any extension	*441 + XXXX + # XXXX= Digits (0-9) Note: Up to 4 digits	8
Changing the Opening door Access Code	*442 + 0XXX+# 0XXX = New Access Code up to four digits. The first digit of the access code in Speedial mode must be 0. If the new access code is less than four numeric digits, press the # key following entry of the digits. The allowable characters are 0 through 9. Do not use the * or # keys.	0123
*For Outdoor units ONLY Time between DTMF's	*460 + X where: X = 1-9 (each step is 200 msec)	2 (400)
Conversation time limit (sec)	*462 + XX XX = Seconds (10-99) 00 = Unlimited	45 sec
Door opening time limit (sec)	*464 + X XX = Number of seconds (1-9)	3 sec
Changing the programming password	*600 + (new password) Programming access passwords must be four numeric digits. The allowable characters are 0 through 9. Do not use the * or # keys.	1234

OPERATION	COMMAND	DEFAULT
*For PanCam-C Camera instructions	*620 + X X = 0 camera off X = 1 camera on X = 2 camera powered when call button is pressed X = 3 powered by any touch on unit keypad	0

3.6 Entering Special DTMF Characters

Special characters can be entered using the keypad. The following table shows the corresponding keypad entries needed for creating special DTMF characters.

DTMF CHAR.	NUMBER TO DIAL
Digits 0-9	0-9
*	**
Pause	*1, indicates a 1 second pause
#	*4
A	*5
B	*6
C	*7
D	*8

4 Specifications

4.1 General Specifications

Power Supply (External)	12V AC@1.6A (supplied with unit) 12-24V DC@1.6A (optional)
Line Voltage	24-72V DC
DC Leakage	< 10 μ A
On-Hook Insulation (Resistance Between Line Terminal and Ground)	0-100V DC > 5M Ω 100-200 V DC > 30 K Ω 500V AC/50Hz > 20K Ω 100V AC/25Hz > 100K Ω
Ring Capacitor	0.47 μ F \pm 10%
On-Hook Impedance	@50V DC, 40V AC/25Hz>3000 Ω
Ring Detect	27-100 V AC/16-60 Hz
DC Resistance (Off-Hook)	24-66V DC @ 20-100mA/350 Ω
Impedance (Off-Hook)	300-3400Hz 500-700 Ω
Imbalance Ratio	300-3400Hz > 46dB
Return Loss	300-3400Hz > 18dB
Current During Break	< 700 μ A
DTMF Transmission:	
Frequency Tolerance	\pm 1.5%
Frequency Level (High)	-6 to -8dBm
Frequency Level (Low)	-8 to -10dBm
Inter-Digit Pause Time	70-80ms
Relay Switching Current	2A max
Dimensions	
Outdoor Unit	19.4cm x 10.2cm/7.6inch x 4.0inch
Indoor Unit	18.5cm x 9.5cm/7.3inch x 9.5inch
Operating Temperature	Outdoor: -20°C to +50°C/4°F to 122°F Indoor: 0°C to +35°C/32°F to 95°F

4.2 Camera Specifications

Black and White Camera

Model no.	MK-03261C
TV System	EIA/CCIR
Image Sensor Device	1/3" interline transfer CCD
Image Sensor Area	4.8mm x 3.6mm
Horizontal Frequency	15.625KHz
Vertical Frequency	50Hz
Total Pixels	542(H) x 582(V)
Scanning System	625 lines, 50 fields/sec CCIR
Resolution	420 TVL horizontal
Minimum Illumination	0.5 Lux at F2.0
Electronic Shutter	Auto Electronic Shutter 1/50 to 1/100000 sec. Continual
S/N Ratio	Better than 48 dB
Video Signal Output	1.0Vp-p composite video signal at 75 ohm load
Gamma Correction	0.45
Gain Control	Auto Gain Control (AGC)
Lens & View Angle	5.5 mm F5.5 / 60°

Color Camera

Model no.	MTV-54KOPI
TV System	PAL/NTSC
Image Sensor	¼-inch CCD Image Sensor
CCD Total Pixels	542(H) x 586(V)
SYNC System	Internal
Minimum Illumination	0.5 Lux F1.2 5600°K
Resolution	380 TVL/470 TVL (Enhanced)
S/N Ratio	52dB (MIN)/60dB(TYP) (AGC OFF)
White Balance	ATW/AWB/FIX (Zero color rolling)
White Balance Range	AWB, ATW(3200---10000°K) /FIX(3299°K)/
Electronic Shutter	1/50-1/120000 sec.
Video Output	1.0Vp-p composite video signal at 75 ohm
Gamma Correction	0.45
Gain Control	AGC
Lens & View Angle	45° > 0.7 mm

5 Comparison Table

	PanCam		Pancode		Pantel	
	PanCam-C	PanCam-T	Outdoor	Indoor	Outdoor	Indoor
Installation	Outdoor	Outdoor	Outdoor	Indoor	Outdoor	Indoor
Case Type	Aluminum	Aluminum	Aluminum	Plastic	Aluminum	Plastic
Entry Access Code	Yes	N/A	Yes	Yes	N/A	N/A
Internal Door Opening Code from Any Extension	Yes	Yes	Yes	Yes	Yes	Yes
Day/Night Mode	Yes	Yes	Yes	Yes	Yes	Yes
Direct Dialing to any Extension	Yes	N/A	Yes	Yes	N/A	N/A
Busy and Disconnect Detection	Auto	Auto	Auto	No	Auto	Manual
Speed Dial Mode	Yes	N/A	Yes	Yes	N/A	N/A
16 DTMF Character Support	Yes	Yes	Yes	Yes	Yes	Yes
High Quality Speakerphone	Yes	Yes	Yes	Yes	Yes	Yes
Volume Control	Yes	Yes	Yes	Yes	Yes	Yes
Vandal Resistant	Yes	Yes	Yes	No	Yes	No
Supports 12V AC/DC	Yes	Yes	Yes	Yes	Yes	Yes
Supports 24V DC	Yes	Yes	Yes	No	Yes	No
						

