

ROCK-OLA

WARREN

**Service Manual
and Parts
Catalog**

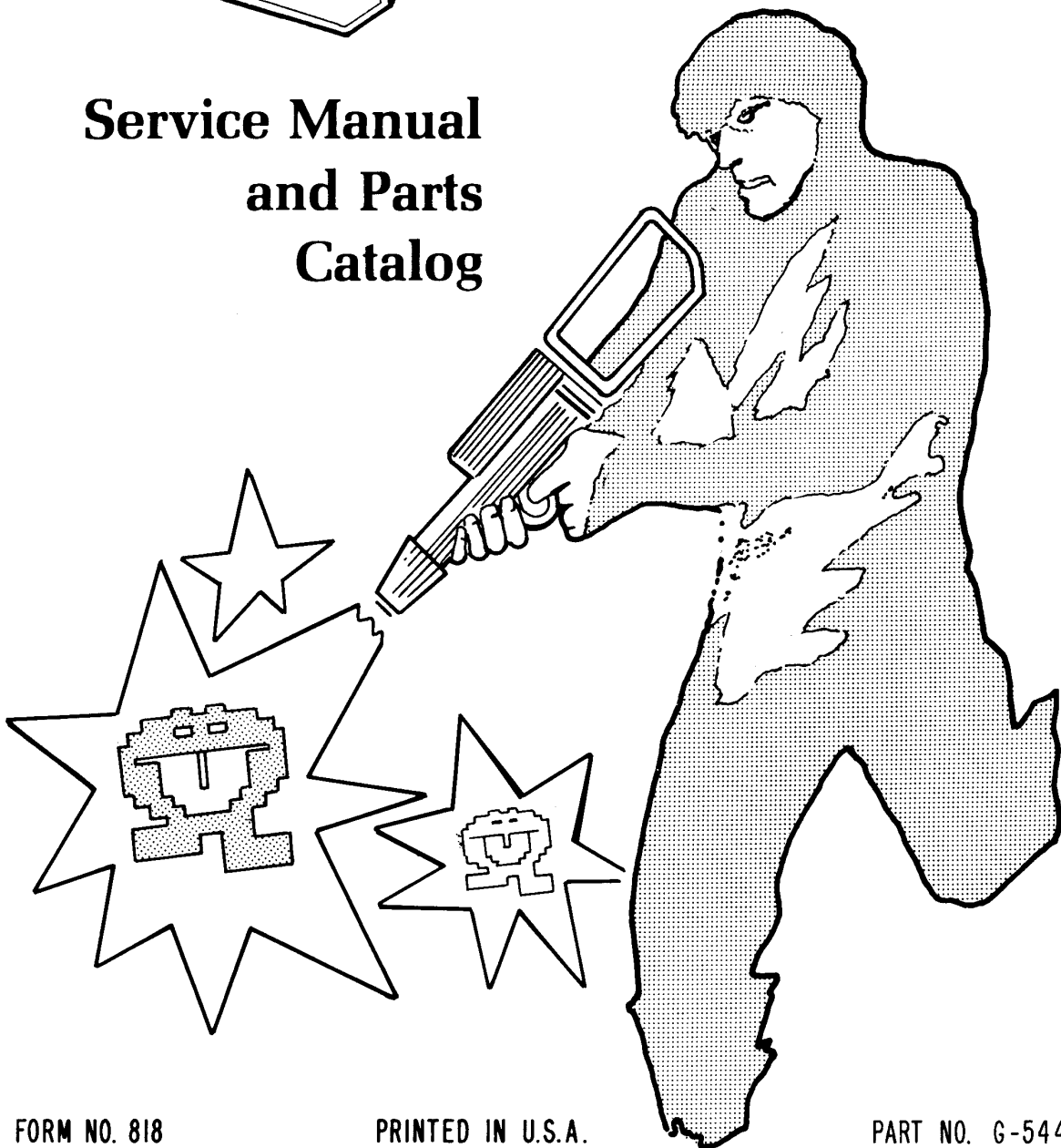

FORM NO. 818

PRINTED IN U.S.A.

PART NO. G-5446-1

TABLE OF CONTENTS

Part 1

Information for Operators

INTRODUCTION..... 1-1

RECEIVING AND
INSTALLING WARP-WARP..... 2-1

GENERAL INFORMATION
AND PERIODIC
MAINTENANCE..... 3-1

HOW TO OPERATE
WARP-WARP..... 4-1

Part 2

Information for Technicians

TROUBLESHOOTING..... 5-1

PARTS LISTS..... 6-1

Appendix A

Assembly Drawings, Schematics, Wiring Diagrams

PART ONE

Information for Operators

SECTION 1

INTRODUCTION TO WARP-WARP

INTRODUCTION

Warp-Warp is an exciting pursuit game that combines colorful action with a reward system for skilful play. Control the fighter with your "joystick" and zap the monsters with the firing button. You play on two different battlefields.

GAME PLAY

The game begins on the Vacuum World where your player zaps the monsters. If your fighter enters the warp zone in the center of the playfield while it's blinking, you'll find him doing battle in the Maze World. Your weapons here are time-delay bombs that your fighter drops, which are set by your pressing the firing button and releasing it. The more monsters destroyed with a single bomb, the more bonus points you earn. On either world the monsters can get your fighter by catching him. On the vacuum world they also fire missiles.

The number of fighters is set by the operator. The game is over when all fighters have been destroyed.

SECTION 2

RECEIVING AND INSTALLATING WARP-WARP

RECEIVING INSPECTION

Your game was shipped in ready-to-play condition. However, after removal of the shipping carton, a brief visual examination is suggested.

Naturally, you'll want to make note of any physical damage to the game cabinet and its external components for freight claim purposes. Considering the quality of the shipping carton, any damage to the exterior would indicate possible interior damage as well.

The interior of the game should also undergo a brief examination for: loose mounting hardware (check to be sure that the major components are still securely mounted); disconnected or loose wires, cables or harnesses; electronic devices loose in their sockets; etc.

At this time the game serial number should be logged. Please remember that the game serial number will be required if you need service from your distributor.

ELECTRICAL REQUIREMENTS

A good earth ground is essential for the proper operation of this game or for that matter any electronic device. Problems with instability and erratic operation of computer-type devices can usually be traced to an ineffective ground system. Therefore, plug the game into a properly wired 3 prong outlet. If a 3 prong to 2 prong AC adaptor must be used, an alternate method of grounding the third prong must be used.

INITIAL ADJUSTMENTS

NOTE

When the game is connected to AC power, one of the game sounds may be heard. This is normal.

WARNING

This equipment generates, uses, and can radiate radio frequency energy and if not installed and used in accordance with the instructions manual, may cause interference to radio communications. As temporarily permitted by regulation it has not been tested for compliance pursuant to Subpart J of Part 15 of FCC Rules, which are designed to provide reasonable protection against such interference. Operation of this equipment in a residential area is likely to cause interference in which case the user at his own expense will be required to take whatever measures may be required to correct the interference.

SECTION 2

RECEIVING AND INSTALLATING WARP-WARP (CONT'D)

INITIAL ADJUSTMENTS

The audio level (volume) can be easily adjusted. This is achieved by rotation of the volume control located on the coin door. The audio level should compete with other machines "on the floor" to maximize play time.

OPERATOR OPTIONS

The option switches allow you to select how many credits per coin, how many fighters per game, bonus scoring, attract mode audio and initials. If your machine DOES NOT have multiple pricing capability, refer to page 2-4. If it DOES have multiple pricing capability, skip 2-4 and refer to page 2-5.

CREDIT BUTTON. When you push this button you can increase credits without affecting the counter. It's the red button on the coin door.

SELF-TESTING

When you turn on the machine, the Warp-Warp game begins a self-test of the game board. If there are no problems, the attract mode will be displayed. If there is a problem, the self-test will be repeated and numbers will appear on the screen. When button is pushed and "BAD ROM" or "BAD RAM" appears, P.C. board may be faulty. If self-test does not reveal the problem, go to test 2.

TEST 2. - Self test with test switch. Test switch is located next to credit button on coin door. Turn on test switch. The game board will be internally checked for 10 seconds. Next, the display below will appear

RAM OK

ROM OK

T or U

1 coin 1 credit

3 fighters

221N

First bonus 8,000 pts.
and every 30,000 pts.

SECTION 2

RECEIVING AND INSTALLATING WARP-WARP (CONT'D)

KEY TO DISPLAY

1. RAM, ROM TEST.

When you turn it on, the Warp-Warp game begins a self-test of the game board. It shows the following display:

Message Displayed	Translation
RAM OK	NO FAULTS FOUND
ROM OK	IN MEMORIES

or one of the following

RAM 1	IC 1W	BAD
RAM 2	IC 1V	BAD
RAM 3	IC 5F	BAD
RAM 4	IC 5H	BAD
RAM 5	IC 6F	BAD
ROM 1	IC 2R	BAD
ROM 3	IC 2M	BAD
ROM 5	IC 1P	BAD
ROM 7	IC 1T	BAD

- If game is a table model, "T" should appear
If game is an upright model, "U" should appear
- Coin/Credit check
- Fighter count
- CONTROL TEST. When you maneuver the joystick, D, U, L, R and N will appear. The screen will also show squares that move around. Certain numbers will appear next to the letters as follows:
D: 0 - 23 U: 24 - 63 L: 64 - 111 R: 112 - 167
N: 168 and up. If the numbers that appear fall between these ranges, there is no problem.
- BONUS SCORING

Maze World Pattern

To display the maze world pattern, turn off the test switch. The pattern will appear for about a second. To retain the pattern, turn on the test switch again. Use this pattern to adjust the monitor.

AUDIO LEVEL

Adjust the audio level to suit desired conditions

Set the pricing and bonus scoring using the tables on pages 2-4 and 2-5

WARP-WARP OPTION SWITCHES
(located on game board near heat sink)

The option switches can be readily seen and reached on the cocktail table model. However, it is best on the upright model to loosen the board and pull it slightly out in order to reach the switches.

TABLE 2-1

SWITCH 1	SWITCH 2	CREDITS/COIN
ON	ON	FREE PLAY
OFF	ON	1/1
ON	OFF	2/1
OFF	OFF	1/2

TABLE 2-2

SWITCH 3	SWITCH 4	FIGHTERS/GAME
ON	ON	2
OFF	ON	3
ON	OFF	4
OFF	OFF	5

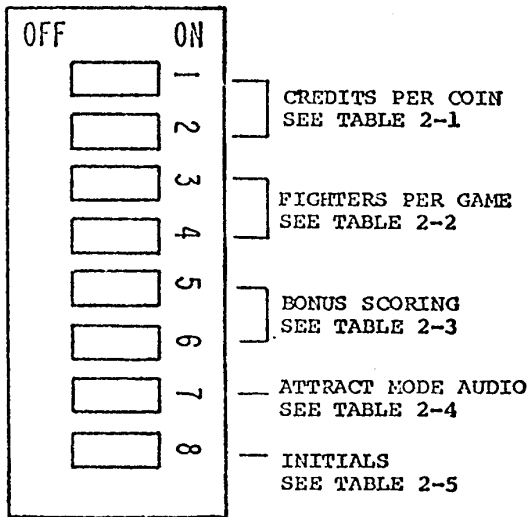

TABLE 2-3

SWITCH 5	SWITCH 6	LOW BONUS/HI BONUS
ON	ON	8,000/30,000
OFF	ON	10,000/40,000
ON	OFF	15,000/60,000
OFF	OFF	NO BONUS

TABLE 2-4

SWITCH 7	ATTRACT MODE AUDIO
ON	YES
OFF	NO

TABLE 2-5

SWITCH 8	INITIALS
ON	YES
OFF	NO

MULTI-PRICE INSTRUCTIONS
(For models with G-5105-1A Multi-price option only)

WARP-WARP OPTION SWITCHES
(located on game board
near heat sink)

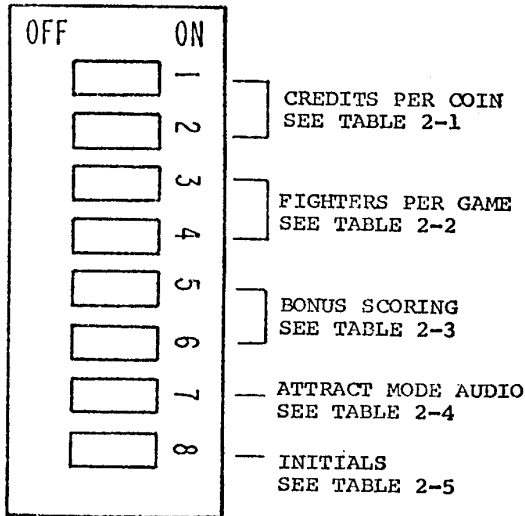

1. To set LOW coin value - follow top chart across to column of value desired.

Example: 1 credit for 1 coin - (column 3). Set logic board switch 1 OFF and switch 2 ON (see illustration at left).

2. To set HIGH coin value - follow chart to value desired on left side of bottom chart. Move to column under value as set above (item #1).

Example: 3 credits for 1 coin - Set multi-price board switch 4 ON - switch 3 ON - switch 2 OFF and switch 1 OFF (column 3).

LOWER VALUE now 1 credit for 1 coin
HIGHER VALUE now 3 credits for 1 coin

LOW DENOMINATION - LEFT REJECTOR
SET LOGIC BOARD SWITCH

COLUMN	1	2	3	4
CREDIT	1 (SW 1 OFF)	2 (SW 1 ON)	1 (SW 1 OFF)	FREE (SW 1 ON)
COINS	2 (SW 2 OFF)	1 (SW 2 OFF)	1 (SW 2 ON)	PLAY (SW 2 ON)

HIGH DENOMINATION - RIGHT REJECTOR
SET MULTI-PRICE BOARD SWITCH

CREDIT	COINS	4 3 2 1				4 3 2 1				4 3 2 1			
		4	3	2	1	4	3	2	1	4	3	2	1
2	1	ON	OFF	ON	ON					ON	ON	OFF	ON
3	1	ON	OFF	OFF	ON					ON	ON	OFF	OFF
4	1	OFF	ON	ON	ON	ON	ON	OFF	ON	ON	OFF	ON	ON
5	1	OFF	ON	OFF	ON					ON	OFF	ON	OFF
6	1	OFF	OFF	ON	ON	ON	ON	OFF	OFF	ON	OFF	OFF	ON
7	1	OFF	OFF	OFF	ON					ON	OFF	OFF	OFF
8	1					ON	OFF	ON	ON	OFF	ON	ON	ON
9	1									OFF	ON	ON	OFF
10	1					ON	OFF	ON	OFF				
3	2	ON	ON	OFF	OFF								
5	2	ON	OFF	ON	OFF								
7	2	ON	OFF	OFF	OFF								
9	2	OFF	ON	ON	OFF								

CIRCUIT DESCRIPTION OF MULTI-PRICING BOARD

The purpose of the multi-pricing board is to establish a pricing scheme for the left rejector that is dependent on but different from that of the right rejector.

In the case of the right rejector, a coin deposited in the rejector will cause a pulse to be transmitted to the C.P.U. (via the distribution P.C. board) where it is processed as a single coin. Coins deposited in the left rejector are handled by the multi-pricing board to produce more than one pulse per coin — the exact number depending on the setting of the multi-pricing switch. When a coin is deposited in the left rejector, U1-5 will go low and be latched to U1 pin 6 as a high until the coin passes the contacts causing U1-6 to go low again. This positive pulse just created will be integrated and shaped as it arrives at U3-5 as a negative

pulse. U3 counts "up" on the positive-going edge and stores the number of coins deposited. As long as any coin remains unprocessed a high will be seen at U1-13 and if U1-12 is also high, a low will be seen at U1-11. This low gets inverted by U4 and applied as a high to the preset enable of counter U6. U6 had been held in the preset mode until this point but is now ready to count down from the value set in by the DIP switch.

The pulses to count down U6 come from oscillator U7 which is enabled shortly after U6-11 goes high. To make sure that U6 doesn't count down until the pre load has gone high, a time delay is introduced by R21, C12, and U2. U7 will oscillate sending pulses to U6 causing its output to count down. These pulses are also the same pulses sent to the CPU board as "coins."

When U6 counts down to zero, a borrow is sent to one-shot U5. U5 will produce a positive pulse at pin 3. U4 will invert this signal and apply it to U3-4 subtracting one coin from the accumulated count. The one-shot will also cause U1-12 to go low for the duration of the pulse. U1-12 going low pre-loads the counter to the DIP switch value again. If another coin is awaiting processing, we will go again; if not U3 outputs 2, 3, 6, 7 will be low keeping oscillator U7 from running and keeping U6-11 low.

The power on reset signal appears on U3-14. Its purpose is to hold U3 reset until the 5 volts has come up and stabilized, preventing U3 from coming up in any configuration other than all lows on its output. This circuit also prevents erroneous pulses to be sent to the C.P.U. board by holding the collector of Q3 low until Q1 turns off.

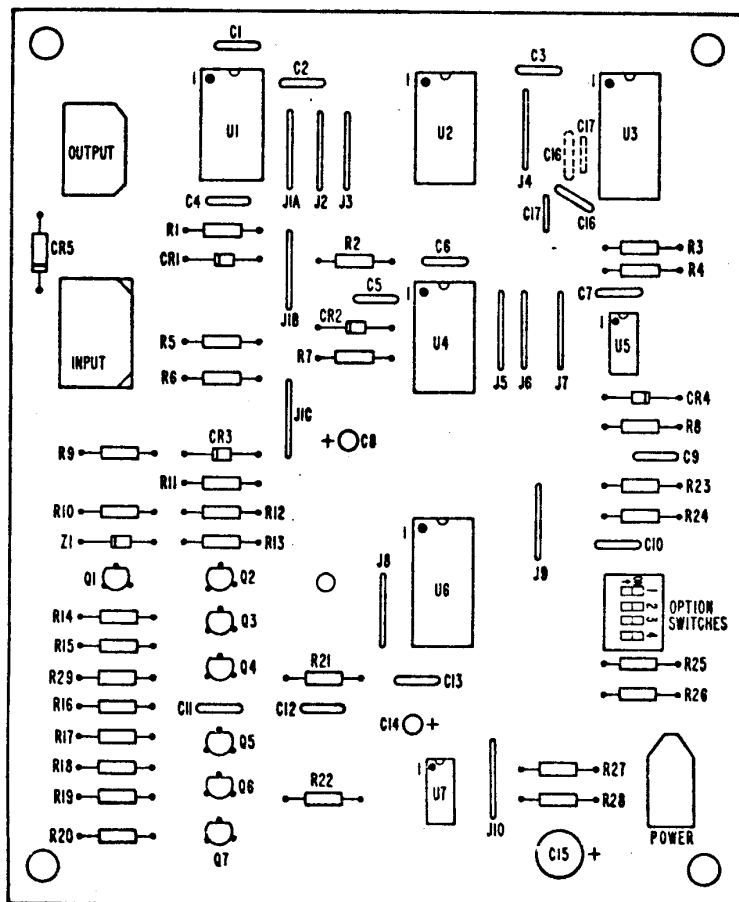

MULTI-PRICING P.C. BOARD ASSEMBLY G-5105-1A
(C16 & C17 IN DASHED LINES ARE FOR G-5105-2A)

MULTI-PRICING
P.C. BOARD ASSEMBLY
G-5105-2A

Item	Part No.	Description	Item	Part No.	Description
RESISTORS			DIODES		
Note: All Resistors 1/4 Watt 5%					
R1	51293	10K	CR1	51498	IN4148
R2	52344	330	CR2	51498	IN4148
R3	51564	1K	CR3	51498	IN4148
R4	50966	100K	CR4	51498	IN4148
R5	51564	1K	CR5	G-5151	IN949
R6	51564	1K	Z1	G-5106	Zener 3.9V 400MW IN478A
R7	50966	100K	TRANSISTORS		
R8	51293	10K	Q1	47831	MPS-A56 (PNP)
R9	52374	47	Q2	49415	MPS-A06 (NPN)
R10	51293	10K	thru		
R11	50966	100K	Q7		
R12	51289	100	INTEGRATED CIRCUITS		
R13	51289	100	U1	G-0677	IC Quad NAND Gate 74LS00
R14	51293	10K	U2	G-0683	IC Quad OR Gate 74LS32
R15	51293	10K	U3	G-5107	4 Bit Binary Counter 74LS193
R16	51292	4.7K	U4	53338	IC Hex Schmitt Trigger 74C14
R17	51292	4.7K	U5	51991	IC Timer LM555
R18	51293	10K	U6	G-5107	4 Bit Binary Counter 74LS193
R19	52374	47	U7	51991	IC Timer LM555
R20	52374	47	MISCELLANEOUS		
R21	52358	2.2K	SW.	G-5108	4 Station Dip Switch
R22	51292	4.7K	Soc.	52720	14 Contact Solder Dip Socket
R23	51293	10K	Soc.	52724	16 Contact Solder Dip Socket
R24	51293	10K	Hsg.	G-5117	2 Circ. Plug Housing
R25	51293	10K	Hsg.	G-0613	.093 Pin Solder Tail
R26	51293	10K	Hsg.	G-0657	6 Circ. Receptacle Hsg
R27	52348	15K		G-5110	.093 Socket Solder Tail
R28	49268	33K	Hsg.	G-5109	6 Circ. Plug Hsg.
R29	51293	10K		G-0613	.093 Pin Solder Tail
CAPACITORS				ST-10759	Standoff - P.C.B.
C1	53299	.1 Mfd 50 WVDC 10%		45816	Rubber Cushion (1/4 X 3/8 X 3 3/4 Lg)
C2	53299	.1 Mfd 50 WVDC 10%		G-5095	P.C. Board for G-5105-A
C3	53299	.1 Mfd 50 WVDC 10%		G-5095-1	P.C. Board for G-5105-1A
C4	53299	.1 Mfd 50 WVDC 10%			
C5	53302	.01 Mfd 50 WVDC 10%			
C6	53299	.1 Mfd 50 WVDC 10%			
C7	53337	.047 Mfd 50 WVDC 20%			
C8	49146	2.2 Mfd 25 WVDC 20%			
C9	53299	.1 Mfd 50 WVDC 10%			
C10	53337	.047 Mfd 50 WVDC 20%			
C11	33762	470 MMfd 1000V 10%			
C12	53302	.01 Mfd 50 WVDC 10%			
C13	53299	.1 Mfd 50 WVDC 10%			
C14	53339	4.7 Mfd 15 WVDC 10%			
C15	52736	33 Mfd 25 WVDC 10%			
C16	53302	.01 Mfd 50 WVDC 10%			
C17	53327	100 MMfd 63 WVDC 5%			

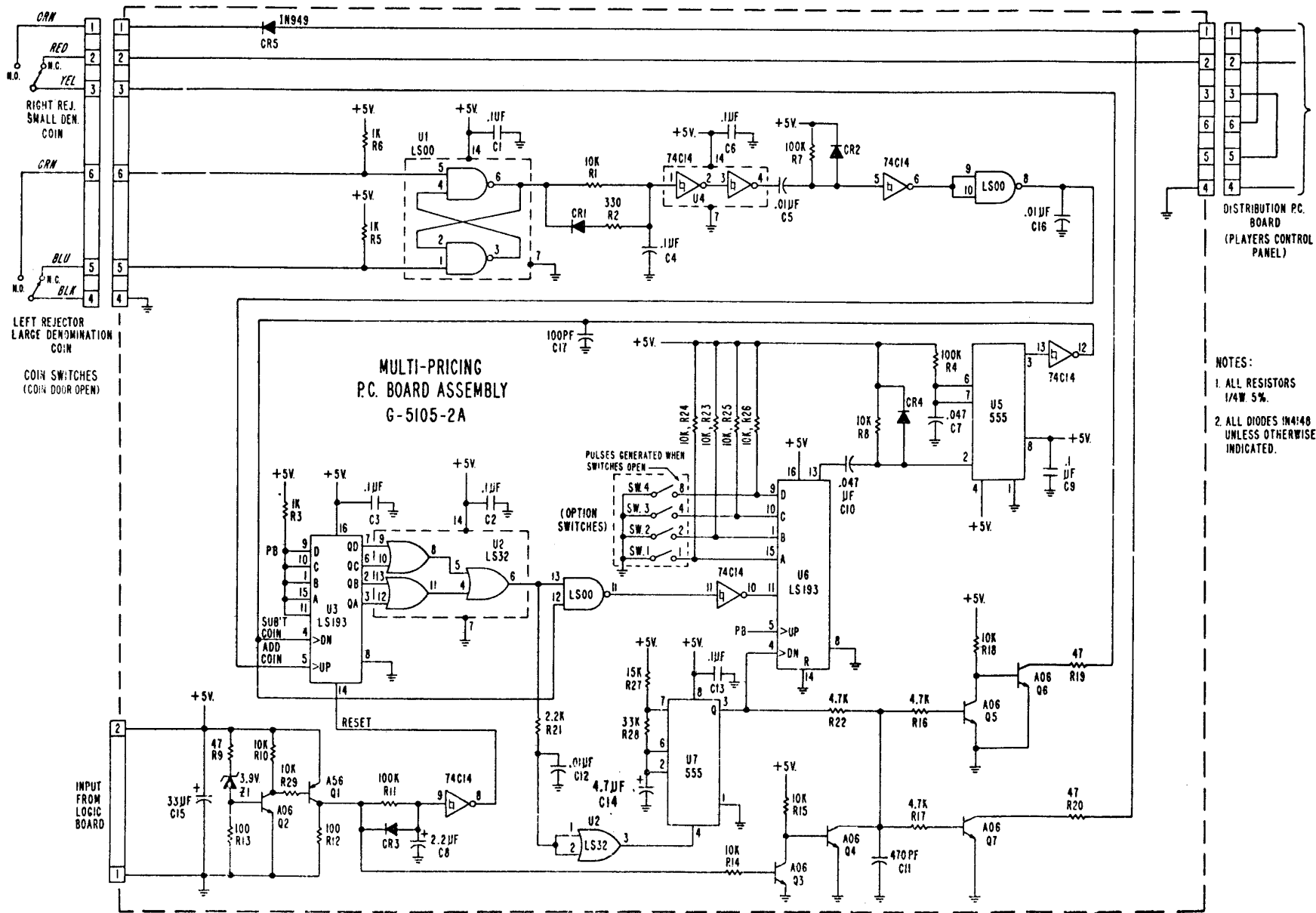

- NOTES:
1. ALL RESISTORS 1/4W. 5%.
 2. ALL DIODES IN4148 UNLESS OTHERWISE INDICATED.

ROCK-OLA WARP-WARP
COUNTER DRIVER P.C. BOARD ASSEMBLY
G-5465-A

When a Multi-Pricing Board is installed we also need a second counter and Counter Driver P.C. Board. The counter Driver P.C. Board contains two identical channels so only the high denomination or left rejector counter circuit will be discussed. The base of Q1 is at 5V until a coin is inserted causing it to go low and turn Q1 on. Q1 turning on will put a high going signal on the base of Q2 causing it to conduct. This applies to ground potential on Q2's emitter to Pin 2 of the output jack. The counter at this point registers another coin deposited.

CR1 is placed across the counter to block the Counter E.M.F. of the Counter's Inductive Switch.

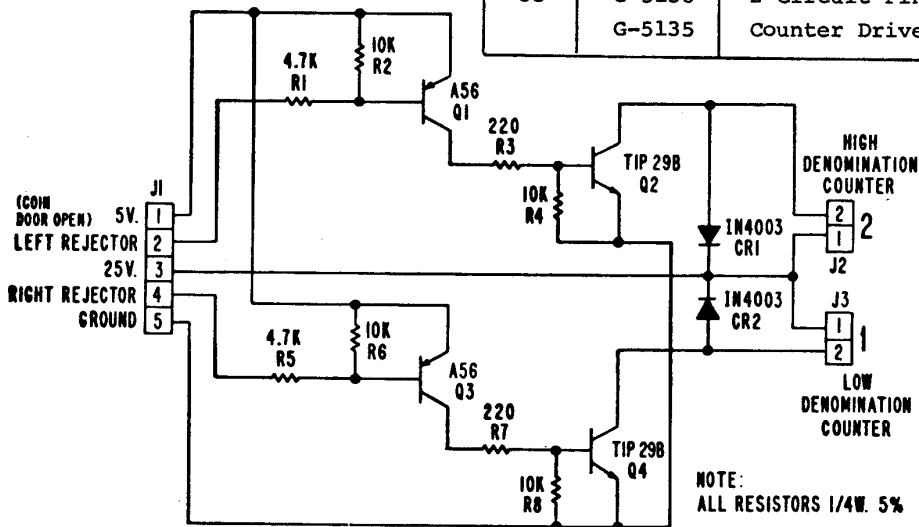
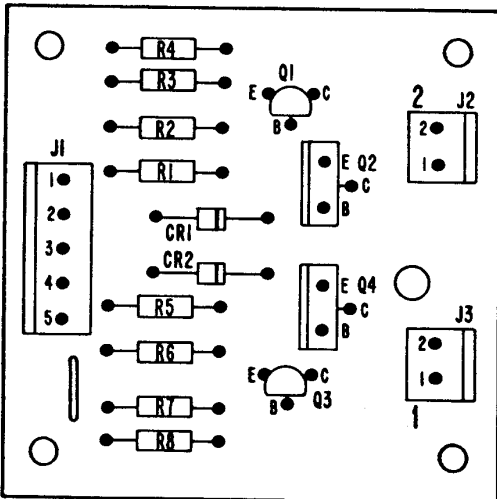

COUNTER DRIVER P.C. BOARD ASSEMBLY
G-5465-A

ITEM	PART NO.	DESCRIPTION
RESISTORS		
NOTE: ALL RESISTORS 1/4W 5%		
R1	51292	4.7K Ohm
R2	51293	10K Ohm
R3	53982	220 Ohm
R4	51293	10K Ohm
R5	51292	4.7K Ohm
R6	51293	10K Ohm
R7	53982	220 Ohm
R8	51293	10K Ohm
DIODES		
CR1	G-0812	IN4003
CR2	G-0812	IN4003
TRANSISTORS		
Q1	47831	MPS-A56 (PNP)
Q2	53736	TIP-29B (NPN)
Q3	47831	MPS-A56 (PNP)
Q4	53736	TIP-29B (NPN)
MISCELLANEOUS		
J1	G-5137	5-Circuit Pin Header
J2	G-5136	2-Circuit Pin Header
J3	G-5136	2-Circuit Pin Header
	G-5135	Counter Driver P.C. Board

CONVENIENCE SWITCH
P.C. ASSEMBLY
G-5455-A

The Convenience Switch assembly performs two functions.

1. Pushing the switch allows operator to add credits without affecting money counter.
2. The circuit provides a regulated 5 volts to money counter and multi-price board.

LOCATED ON COIN DOOR VOLUME CONTROL
DOOR BRACKET

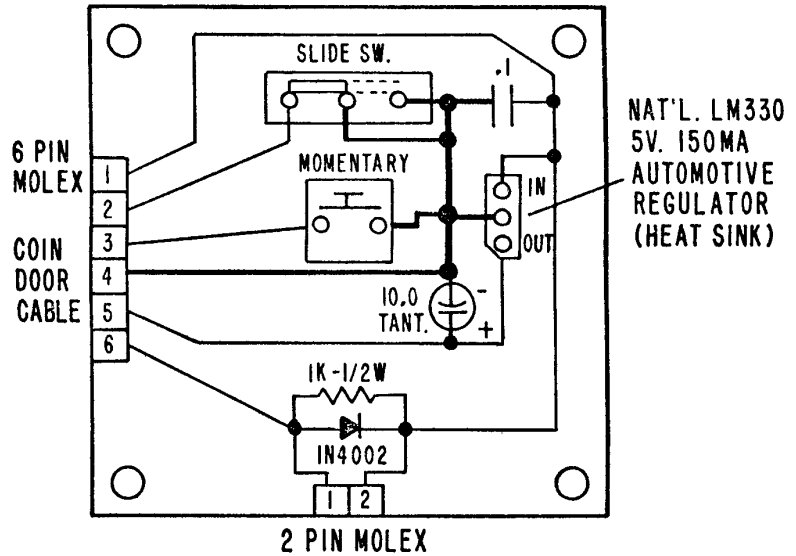

COIN COUNTER #1 FOR SINGLE PRICE OPERATION ONLY
(6VDC TYPE)

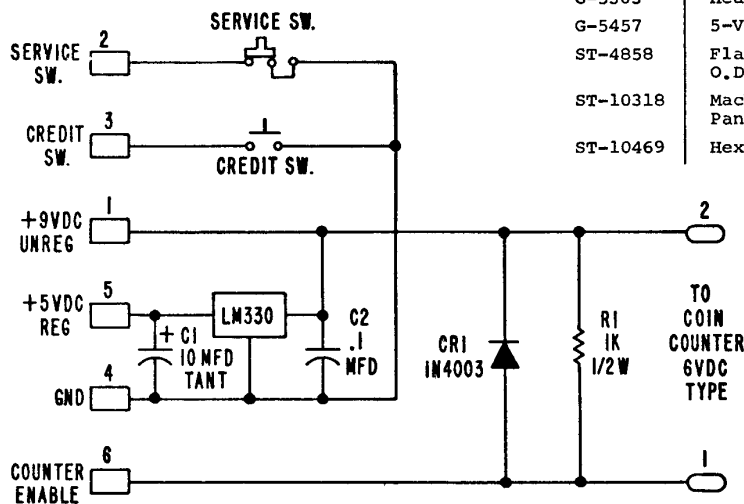

PART NO.	DESCRIPTION	REF. DES.	MFR. PART NO.
G-5456	Convenience Switch P.C. Assembly Board		
16224	Resistor 1/2W 5%	R1	1K Ohm
G-0812	Diode	CR1	IN4003
53299	Capacitor, Monolythic	C2	.1 mf
52561	Capacitor, Tantalum	C1	10 mf
52725-02	Key Switch - Red		
52727	SPDT Miniature Slide Switch		
G-5459	6-Circuit Pin Header		9-60-1061
G-5136	2-Circuit Pin Header		
G-5303	Heatsink		
G-5457	5-Volt Regulator		TO-220
ST-4858	Flat Washer 9/64 I.D. X 3/8 O.D. X .020 - Z.P.		
ST-10318	Machine Screw 4-40 X 5/16 Pan. Hd. Cad.		
ST-10469	Hex Nut 4-40 Twin Serr.		

SECTION 3

GENERAL INFORMATION AND PERIODIC MAINTENANCE

Your Warp-Warp game contains the same basic building blocks as any other video game.

THE POWER SUPPLY provides all the necessary voltages for the CPU, audio section, monitor and fluorescent light. Always unplug the game before replacing a fuse.

THE CENTRAL PROCESSING UNIT (CPU) is the "brain" of the game. It senses when a coin is dropped in the coin meter, and gives credit. It then reads what is happening at the operator controls, interprets and computes to make the game play according to what buttons the player pushes. It tells the monitor what to draw on the screen. And it tells the audio section when to make appropriate sound effects.

THE AUDIO SECTION generates all the sound effects for the game and powers the loudspeaker.

THE COLOR MONITOR is the picture tube. It draws pictures on the tube screen according to the instructions it receives from the CPU.

THE MAIN WIRING HARNESS carries power from the power supply to the CPU, audio section and monitor. It connects to each section through the Molex plugs. NEVER CONNECT OR DISCONNECT THE MOLEX POWER PLUGS UNLESS THE GAME IS UNPLUGGED.

PERIODIC MAINTENANCE - The only Periodic Maintenance required is an occasional cleaning. The very high voltage used on the picture tube attracts dust that gradually degrades picture quality. To clean: unplug game and let sit for at least 5 minutes to let voltages "bleed-off".

To clean the face of the picture tube and the plexiglas cover, use a mild solution of dish detergent, which will clean the plexiglas without harming the color decal. Care should be taken to not rub the decal, as it may be brittle with age.

SECTION 4
HOW TO OPERATE WARP-WARP

1. Playing the Game

The game is played on two battlefields. When the game begins, your fighter is in the warp zone of the Vacuum World. He seeks out and destroys the monsters by zapping them. You accomplish this with the firing button. You control your fighter's movements with the joystick. The monsters shoot missiles at your fighter and try to catch him in order to destroy him. If your fighter enters the warp zone while it's blinking, he'll find himself in the Maze World. Here he must avoid the monsters and defend himself by dropping time-delay bombs. This is accomplished by your pushing the firing button and releasing it. The monsters do not shoot missiles and your fighter has only the bombs for a weapon, which can also destroy him if he gets caught in the blast zone.

2. Scoring

On the Vacuum World, destroying 3 of the same color monsters in a row causes a bonus monster to appear. Points are awarded as follows:

Yellow Monster	60	Orange Monster	90	Red Monster	150
----------------	----	----------------	----	-------------	-----

If you shoot 3 yellow monsters in succession, a green frog will appear. Shoot 3 orange monsters and a blue octopus will appear. Shoot 3 red monsters and a purple lobster will appear.

Green Frog	500	Blue Octopus	1000	Purple Lobster	2000
------------	-----	--------------	------	----------------	------

On the Maze World, the more monsters you destroy with the same bomb, the more bonus points you earn as follows:

2 monsters with 1 bomb	500
3 monsters with 1 bomb	1000
4 monsters with 1 bomb	2000

Additionally, when you've scored 8,000 points you're awarded an extra fighter and also for each additional 30,000 points. Bonuses can be adjusted by operator... see table 2-3 on page 2-4.

When only two monsters remain on the board, or whenever player is maneuvering to avoid a confrontation, the action speeds up. The number of fighters is set by the operator...see table 2-2 on page 2-4.

HOW TO OPERATE WARP-WARP (CONT'D)

3. Initials

If your score is among the five best on a given day, you can register your initials along with your score for display during the attract mode. Option switch 8 (see page 2-4) must be ON. Here's how you accomplish registering your initials:

- a. While in attract mode after the game, move joystick to the right. The computer will run through the alphabet.
- b. When initial you wish to register appears, return joystick to neutral.
- c. Push the firing button to register your initials. Repeat this procedure 3 times to register a maximum of 3 initials.

When game is set for 1 to 4 players, the threshold for registering scores and initials is 8,000 points. However, when game is set for 5 players, the threshold is raised to 30,000 points. Even if player does not register initials when qualified, his high score will be displayed in the attract mode. To erase the scores and initials, remove power or turn option switch #8 OFF (see page 2-4).

PART TWO

Information for Technicians

SECTION 5

BASIC TROUBLESHOOTING

GENERAL

Be careful - certain components of monitor utilize high voltage

Solid-State Control Panel

Turn off power before changing components

Do not use VOM on P.C. Board as use may damage P.C. Board components

When attaching connectors, be sure to observe polarity

K4600 COLOR MONITOR SAFETY INFORMATION

WARNING:

An isolation transformer must be used between the AC supply and the AC plug of the monitor before servicing or testing is performed since the chassis and the heat sink are directly connected to one side of the AC line, which could present a shock hazard. The chassis of the monitor should NEVER be connected to ground. Before servicing is performed, read all the precautions labeled on the CRT and chassis.

WARNING:

Parts which influence x-ray radiation in horizontal deflection, high voltage circuits and picture tube etc. are indicated by ★ in the parts list for replacement purposes. Use only the type shown in the parts list.

WARNING:

For continued safety replace safety critical components only with manufacturer recommended parts. These parts are identified by shading and by △ on the schematic diagram.

For replacement purposes, use the same type or specified type of wire and cable, ensuring that the positioning of the wires is followed (especially for high voltage and power supply circuits). Use of alternative wiring or positioning could result in damage to the monitor or in a shock or fire hazard.

The picture tube used employs integral implosion protection and should be replaced with a tube of the same type number for continued safety.

IMPORTANT: In the event that game exhibits erratic behavior, i.e. resetting in the middle of a game, or failure to power op, **CHECK THE FUSES!**

SECTION 5

BASIC TROUBLESHOOTING (CONT'D)

When handling the CRT, shatterproof goggles should be worn after completely discharging the high voltage circuit. DO NOT lift the picture tube by the neck.

PERFORMANCE AND OPERATING DATA

Apply a suitable power source to the monitor through an isolation transformer.

Apply a suitable signal source to the monitor PCB by means of P205.

Set up controls.

All controls are preset at the factory, but may be adjusted to suit program material.

1. SUPPLY

Voltage 108 VAC - 132 VAC

Frequency 50 Hz - 60 Hz

Note: Apply supply voltage through an isolation transformer with 1 Amp. capability.

2. HIGH VOLTAGE (EHT)

For 19"V models 25.5 ± 0.8 K.V. at 0 Beam

Note: Condition for above 1 (beam) = 0
A.C. = 120V

3. SERVICE SET-UP CONTROLS

A. V. Adjustment VR501 set for 127V DC

B. Vertical Size Cont = VR302

C. Vertical Hold Cont = VR301

D. Horizontal Hold Cont = VR351

E. Horizontal Width Cont = L702

F. Focus Control = VR702

G. Screen Control = VR406

H. Video Drive Controls - Red Drive = VR401

Green Drive = VR402

I. CRT Cut Off Controls - Red Cutoff = VR403

Green Cutoff = VR404

Blue Cutoff = VR405

SECTION 5

BASIC TROUBLESHOOTING (CONT'D)

COLOR MONITOR SERVICE INSTRUCTIONS

FOCUS

Adjust the Focus control (VR702), located on the HV unit (T701), for maximum over-all definition and fine picture detail.

+127V ADJUSTMENT (See Fig. 1)

The +127V adj. control (VR501) is adjusted at the factory. However, if readjustment should be required, proceed as follows.

1. Operate monitor for at least 15 minutes at 120V AC line.
2. Connect Positive lead of V.T.V.M. to blue lead of TR502 negative lead to chassis ground.
3. Adjust VR501 to obtain +127V reading.
4. After adjustment VR501 must be locked with a sealing varnish.

CIRCUIT PROTECTION

A 3.0A pigtail fuse, mounted on the Main Board has been provided to protect the Power Output Circuit.

HORIZONTAL OSC. ALIGNMENT

(See Fig. 2)

A warm-up period of at least five minutes should be allowed before alignment is carried out. Set VR351 to center position. Adjust L351 after grounding R328 plug. (TP32 of Vert/Horiz. P.C. Board) through a $1\mu\text{F}/50\text{V}$ capacitor. Adjust L351 to obtain normal picture.

After adjustment, remove $1\mu\text{F}/50\text{V}$ capacitor.

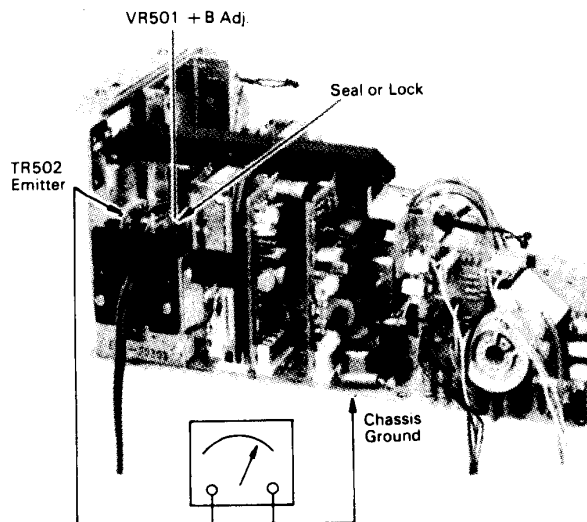

FIGURE 1

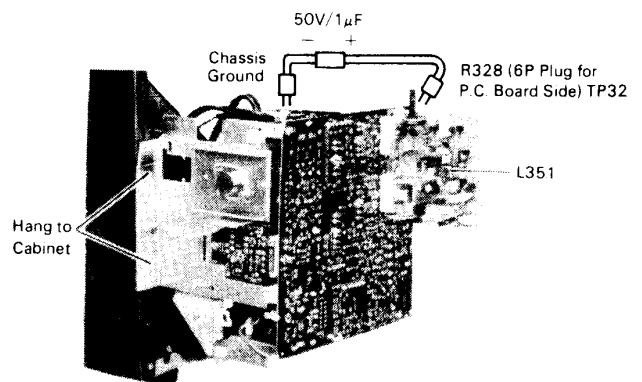

FIGURE 2

SECTION 5

BASIC TROUBLESHOOTING (CONT'D)

COLOR MONITOR SERVICE INSTRUCTIONS

BLACK LEVEL CONTROL ADJUSTMENT

This control has been set at the factory and should not need further attention. If however when the game is connected a slight adjustment of VR201 may be necessary to obtain the proper black level (the black portion of the picture just extinguished).

VERTICAL SIZE (HEIGHT)

The vertical height control is a screw-driver adjustment. Location of this control is shown in Fig. 3. This control must be adjusted slowly, if necessary, until the picture or test pattern attains the correct vertical proportions.

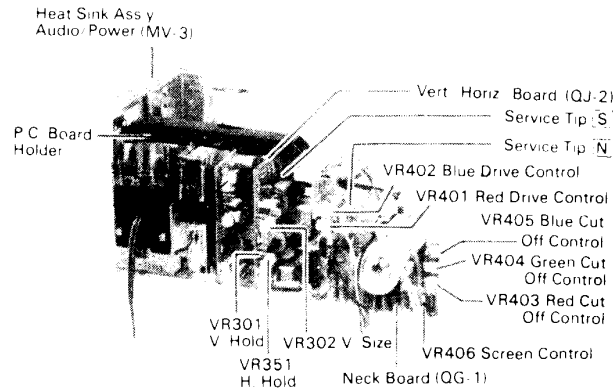

FIGURE 3

INSTALLATION AND SERVICE INSTRUCTIONS

COLOR PURITY AND VERTICAL CENTERING ADJUSTMENT

For best results, it is recommended that the purity adjustment be made in the final monitor location. If the monitor will be moved, perform this adjustment with it facing west or east. The monitor must have been operating 15 minutes prior to this procedure and the faceplate of the CRT must be at room temperature. The monitor is equipped with an automatic degaussing circuit. However, if the CRT shadow mask has become excessively magnetized, it may be necessary to degauss it with manual coil. Do not switch the coil OFF while the raster shows any effect from the coil.

SECTION 5

BASIC TROUBLESHOOTING (CONT'D)

INSTALLATION AND SERVICE INSTRUCTIONS

COLOR PURITY AND VERTICAL CENTERING ADJUSTMENT (CONT'D)

Purity Magnets are used for Color Purity and V Centering Adjustment.

Purity Adjustment procedure is as follows.

1. Remove R-G-B signal from monitor.
2. Turn Green Cut off Control (VR404) on the Neck Board fully CCW.
Turn Red and Blue Cut off Control (VR405) fully CW.
3. Pull the Deflection Yoke backward so that the Magenta belt will appear. (See Fig. 4)
4. Move the two Purity Magnets and bring the Magenta belt to the mechanical center of the screen (See Fig. 5) The vertical center position should be set VRS to $-5/64$ " (-2 MM) as shown in Fig. 6.
Insert service tip "N" on Neck circuit board to "S" on Vert./Horiz. circuit board (See Fig. 13). To check, use the Green raster at low intensity. Be sure to return the service tips to their original positions for the next check.
5. Push the Deflection Yoke forward gradually and fix it at the place where the Magenta screen becomes uniform throughout.
6. Turn Cut off Control, and Drive Control and confirm that each color is uniform.
7. If the color is not uniform, re-adjust it moving Purity Magnets slightly.
8. Move a pair of Purity Magnets at the same time (do not change the angle of the pair), and adjust the vert. center to center of screen.
9. Obtain the three colors and confirm whether white uniformity is balanced.
10. Insert the temporary wedge as shown in Fig. 5 and adjust the angle of Deflection Yoke.

STATIC CONVERGENCE ADJUSTMENT

A recently developed Deflection Yoke and Electron Guns construction has been used on this equipment in combination with In-Line Guns and Black Stripe Screen to make a barrel-type magnetic-field distribution for vertical deflection and a pin-cushion-type magnetic field for horizontal deflection with which a self-converging system can be obtained. This type is different from conventional unity-magnetic field distribution type deflection yoke. 4-Pole Magnets and 6-Pole magnets are employed for static convergence instead of a Convergence Yoke.

SECTION 5

BASIC TROUBLESHOOTING (CONT'D)

STATIC CONVERGENCE ADJUSTMENT (CONT'D)

1. A cross hatch signal should be connected to the monitor.
2. A pair of 4-Pole Convergence Magnets are provided and adjusted to converge the blue and red beams. When the Pole opens to the left and right 45° symmetrically, the magnetic field maximizes. Red and blue beams move to the left and right oppositely (See Fig. 7-a and 7-b). Variation of the angle between the tabs adjusts the convergence of red and blue vertical lines. When the both 4-Pole Convergence Magnet Tabs are rotated as a pair, the convergence of the red and blue horizontal lines is adjusted.
3. A pair of 6-Pole Convergence Magnets are also provided and adjusted to converge the magenta (red + blue) to green beams. When the Pole opens to the left and right 30° symmetrically, the magnetic field is maximized. Red and blue beams both move to the left and right (See Fig. 8-c and 8-d). Variation of the opening angle adjusts the convergence of magenta to green vertical lines. When both 6-Pole Convergence Magnet Tabs are rotated as a pair the convergence of magenta to green horizontal lines is adjusted.

PRECISE ADJUSTMENT OF DYNAMIC CONVERGENCE (See Fig. 10 and 11)

1. Feed a cross hatch signal to the monitor.
 2. Insert the temporary wedge and fix Deflection Yoke so as to obtain the best circumference convergence (See Fig. 10 and 11).
- NOTE:
The temporary wedges may need to be moved during adjustments.
4. Insert three rubber wedges to the position as shown in Fig. 9 to obtain the best circumference convergence.

NOTE:

- 1) Tilting the angle of the yoke up and down adjusts the crossover of both vertical and horizontal red and blue lines. (See Fig. 10 (a) and (b)).
- 2) Tilting the angle of the yoke sideways adjusts the parallel convergence of both horizontal and vertical lines at the edges of the screen. See Fig. 11-a and b.
- 3) Use three rubber wedges (thick and thin rubber wedges are used for a purpose).
- 4) The angle of each rubber wedges are shown in Fig. 9.
- 5) After three rubber wedges have been inserted, pull out the temporary wedge.
- 6) Fix the rubber wedges with chloroprene rubber adhesive.

SECTION 5

BASIC TROUBLESHOOTING (CONT'D)

BLACK AND WHITE TRACKING (With R/G.B. inputs grounded)

1. Set Black Level Control (VR201) to mid point.
2. Set Red and Blue Drive Controls (VR401 & VR402) to their mechanical center.
3. Set the G2 Screen Control (VR406) and the 3 Cut-off Controls (VR403, VR404, & VR405) to minimum (CCW).
4. Slowly turn up G2 screen control until the first faint color appears.
5. Slowly turn up the other two color cut-off controls in turn to match the first.
6. Remove ground from R/G/B/ inputs. Adjust Red and Blue Drive Controls (VR401 & VR402) for white screen.

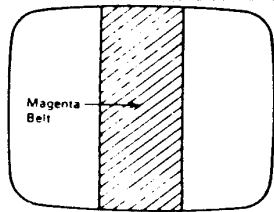

FIGURE 4

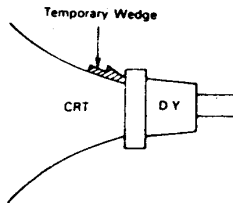

FIGURE 5

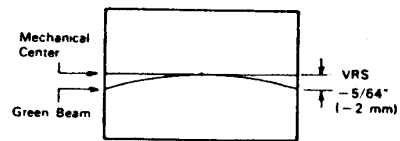
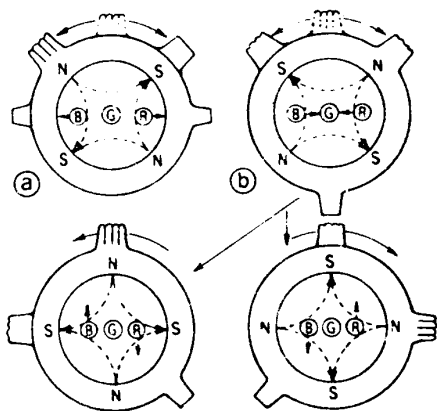
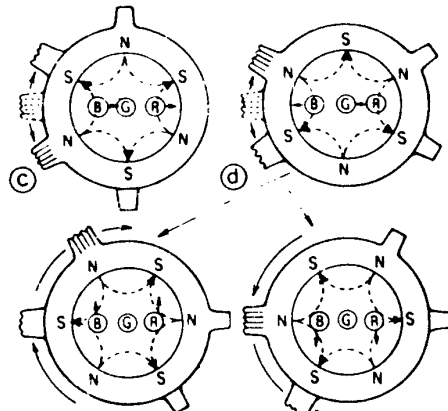

FIGURE 6



4-Pole Magnets and the Movement of Beams

FIGURE 7



6-Pole Magnets and the Movement of Beams

FIGURE 8

INSTALLATION AND SERVICE INSTRUCTIONS

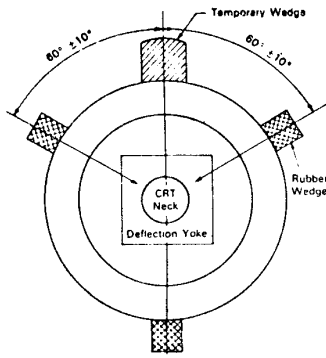
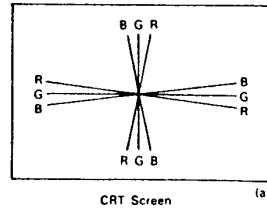
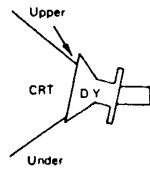

FIGURE 9



CRT Screen (a)



Insert Rubber Wedge from Upper Side

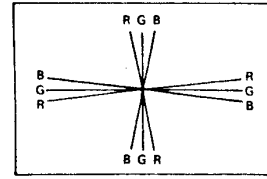

CRT Screen (b)

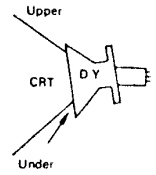

Insert Rubber Wedge from Lower Side

FIGURE 10

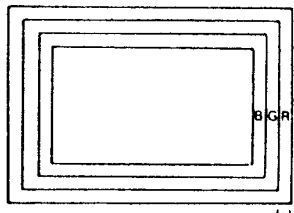

CRT Screen (a)

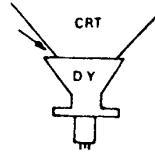

Insert Rubber Wedge from Left Side

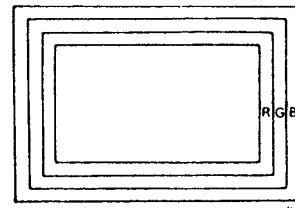

CRT Screen (b)

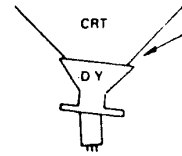

Insert Rubber Wedge from Lower Side

FIGURE 11

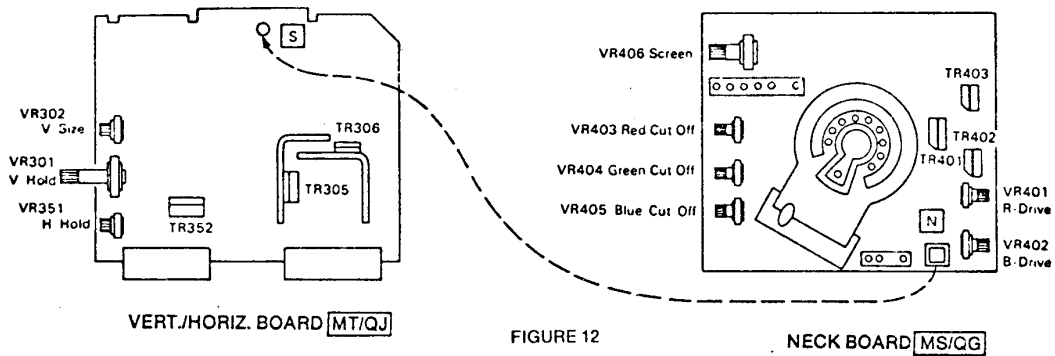
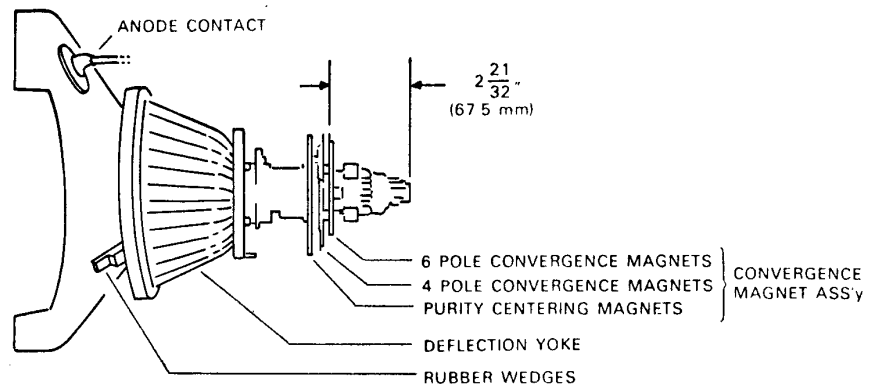
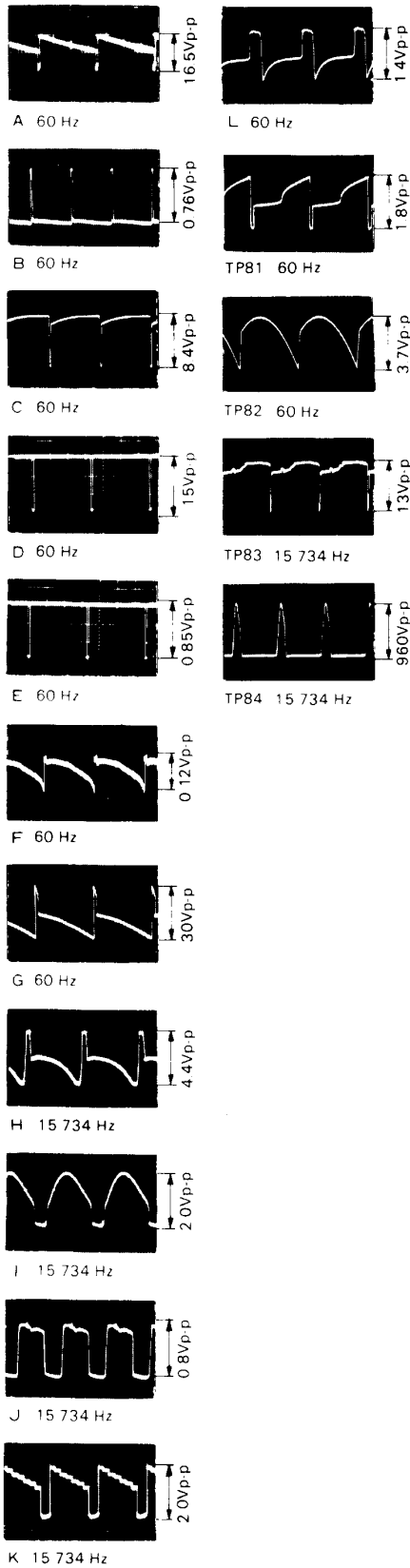

FIGURE 12

FIGURE 13.
PICTURE TUBE NECK
COMPONENTS LOCATION





Power Supply Voltage and Symbols

Symbols	Line Voltage	Working Circuit
	15V	Vert. — Drive stage ABL — Bias CRT Cut-Off
	30V	Vert. Output Side pin Trans. — Bias
	127V	Horiz. Osc. Horiz. Drive Horiz. Output
	160V	Video Output
	890V	Screen-Bias



**SERVICE TECHNICIAN WARNING
X-RAY RADIATION PRECAUTION:**

THIS PRODUCT CONTAINS CRITICAL ELECTRICAL AND MECHANICAL PARTS ESSENTIAL FOR X-RAY RADIATION PROTECTION.

FOR REPLACEMENT PURPOSES, USE ONLY TYPE PARTS SHOWN IN THE PARTS LIST.



CAUTION: FOR CONTINUED SAFETY, REPLACE SAFETY CRITICAL COMPONENTS ONLY WITH MANUFACTURER'S RECOMMENDED PARTS.

AVERTISSEMENT: POUR MAINTENIR LE DEGRE DE SECURITE DE L'APPAREIL NE REMPLACER LES COMPOSANTS DONT LE FONCTIONNEMENT EST CRITIQUE POUR LA SECURITE QUE PAR DES PIECES RECOMMANDEES PAR LE FABRICANT.

OSCILLOSCOPE WAVEFORM PATTERN

The waveforms shown are as observed on the wide band oscilloscope with the monitor turned to a reasonably strong signal and a normal picture. The voltages shown on each waveform are the approximate peak amplitudes. The frequency accompanying each waveform indicates the repetition rate of waveform not the sweep rate of the oscilloscope.

If the waveforms are observed on the oscilloscope with a poor high frequency response, the corner of the pulses will tend to be more rounded than those shown and the amplitude of any high frequency pulse will tend to be less.

SECTION 5
BASIC TROUBLESHOOTING (CONT'D)

1. Wiring and Connectors

Check wiring and connectors in probable trouble area.

2. Coin Counter Circuit

Locate the diodes in the coin counter circuit. Attach positive lead or VOM to anode, negative lead to cathode. Coin counter circuit should read about 80 ohms. If problem doesn't surface during this check, isolate diodes and check again.

3. To check Power Supply

Edge connector J1 attached - power on

A. Primary	90-100 VAC	OK - go to B
	below 90V	Raise to 100V
	0V	Check 3A fuse
B. Secondary	Check if proper voltage is supplied	If YES, transformer is OK. If NO, go to C
C. 3A Fuse	Fuse blows	Transformer or Monitor on Logic Board or harness-jumper is out of order
	Fuse stays off	P.C. board may be faulty

4. To check Game Board

Disconnect J1 - power on

No display	Check A(1)-C(3) of J1 for +15VAC	When voltage is not OK, wiring may be open or shorted. When voltage and audio are OK, monitor may be faulty. When voltage is OK and audio is not OK, PCB may be faulty
Game does not operate properly	Check fuses	Primary cause of failure to power up, or to reset during game
No sound Distorted sound	Check X(20-2(22) of J1 for +25VAC	When voltage is not OK, wiring may be open or shorted. Switching regulator may be faulty
Coin counter does not work properly	Check voltage	When voltage is OK, PCB may be faulty.

WARP-WARP

PARTS LIST

G-201

OVERALL ASSEMBLY

ITEM NO.	PART NO.	DESCRIPTION
1	G-5410-A	Cabinet Assembly
2	G-5430-A	Control Panel Assembly
3	G-5290-A	Monitor Assembly
4	G-5415-A	Game P.C. Board Assembly
5	G-5435-A	Power Supply - Complete
6	G-5446-1	Parts Catalog
CABINET ASSEMBLY		
G-5410-A		
1	G-24115-A	Cabinet - Wood
2	G-5427-A	Main Cable Assembly - Cabinet
3	G-5409-A	Braided Shield Assembly - Cabinet
4	G-5442	Decal - R.H.
5	G-5443	Decal - L.H.
6	G-5245-A	Coin Door - Complete - Canada and Domestic
	G-5245-AA	Coin Door - Complete - Australia
	G-5245-BA	Coin Door - Complete - Belgium
	G-5245-FA	Coin Door - Complete - France
	G-5245-GA	Coin Door - Complete - Germany
	G-5245-JA	Coin Door - Complete - Japan
7	G-5426-A	Coin Switch Cable Assembly
8	ST-3340-D	10-24 X 1 1/4 Carriage Bolt - Black Oxide
9	ST-4813	.203 I.D. X 1/2 O.D. X .032 Fl Washer - Z.P.
10	ST-8724-D	10-24 Hex Flg Whiz Lock Nut - Black Oxide
11	G-5199	Mounting Rail
12	ST-1443-D	1/4-20 X 1 1/4 Carriage Bolt - Black Oxide
13	ST-301	1/4 Internal Lockwasher
14	ST-1376	1/4-20 Wingnut
15	G-5435-A	Power Supply - Complete - Warp
16	G-5409-A	Braided Shield Assembly - Short
17	ST-3341-D	8-32 X 1 Carriage Bolt - Black Oxide
18	ST-8721	8-32 Hex Flg Whiz Lock Nut - Z.P.
19	G-5022	Speaker - 6 X 9
20	G-5282	Speaker Grille - Black
21	ST-10768	10-32 X 1/2 Carriage Bolt - Z.P.
22	ST-9711	10 X 11/16 Hex Flg (Type A) - Z.P.
23	C-5012-1	Tongue Bracket - C.B.
24	G-5048-A	Coin Box and Handle Assembly
25	G-5014	Coin Box Cover

CABINET ASSEMBLY

G-5410-A

ITEM NO.	PART NO.	DESCRIPTION
26	ST-9741	8 X 1/2 Hex Flg (Type A) - Z.P.
27	G-5290-A	Monitor Assembly
28	G-5439	Retainer - P.C. Board - Runner - R.H. Top
29	G-5342	Clamp Fastener
30	ST-4061	10 X 3/4 Phil P.H. (Type A) - Z.P.
31	ST-10402	1/2 Locking Clamp
32	ST-9712	8 X 3/8 Hex Flg (Type A) - Z.P.
33	G-5430-1A	Control Panel Assembly
34	G-5469	Retainer - Front - Black
35	49557	Ballast Plate
36	49554-2	Ballast Insulator
37	ST-10894	8 X 3/4 Hex Flg (Type A) - Z.P.
38	G-5413-A	Light Assembly - Complete - 120V
39	G-5414-A	Light Assembly - Complete - 220/240V
40	G-5412-A	Light Cable - 120V - Light Assembly
41	G-5411-A	Light Cable - 220/240V - Light Assembly
42	G-5043	Fluorescent Lamp (F15T12) CW 15W
43	11556	14-15-20W Starter (FS-2) 120V
44	49301	Insulated Starter 20W 220/240V
45	46861	Flur-O-Lock
46	G-5254	Retainer - Innertop - Black
47	46169-6 1/2	Foam Cushion - Upper Top Cleats
48	46169-22 1/4	Foam Cushion - Mount to Retainer
49	ST-10753-D	8 X 5/8 Pan Hd Box Drive (Type A) - Black Oxide
50	G-5407-A	Monitor and Platform Assembly
51	G-5290-A	Monitor - 19" - (RGB) Raster
52	G-5406-A	Monitor Platform Assembly
53	G-5428-A	Monitor Power Cable
54	G-24073	Monitor Platform Rail
55	G-5441	End Mounting Bracket
56	G-0831	Bezel - CRT - Black
57	G-5436	CRT Filter - Gray
58	G-5415-A	Game P.C. Board Assembly
59	G-5434	Top Window
60	G-5408-A	CRT Window - Vertical Assembly
61	G-5247	CRT Window - Vertical
62	40654	Foam Cushion - CRT Window
63	G-5249	Retainer - Rear - Black
64	G-5252	Retainer - Center - Black
65	G-5257-1A	Back Door Assembly - Complete
66	G-24085-A	Back Door Assembly
67	G-5126	Lock Bracket
68	ST-10760	Lock, Cam Bolts, Keys
69	G-5031	Price Card - 25¢
	G-5033	Price Card - Belgium
	G-5037	Price Card - England
	G-5032	Price Card - Germany
	G-5034	Price Card - France

CABINET ASSEMBLY

G-5410-A

ITEM NO.	PART NO.	DESCRIPTION
70	G-5373-A	Interlock Switch and Cable Assembly - 120V - Canada and Domestic
71	G-5373-JA	Interlock Switch and Cable Assembly - 100V - Japan
72	G-5373-GA	Interlock Switch and Cable Assembly - 220V - Germany, France, Belgium
73	G-5373-EA	Interlock Switch and Cable Assembly - 240V - England

GAME P.C. BOARD ASSEMBLY

G-5415-A

ITEM NO.	PART NO.	DESCRIPTION	REF DES.	MFGR. PART NO.
1	G-5416	Game P.C. Board		
2	G-0677	Quad 2-input NAND Gate	2A, 3N	74LS00
3	G-0679	Hex Inverter	4B	74LS04
4	G-0680	Quad 2-input AND Gate	2D, 5N, 6J, 6K, 4V	74LS08
5	G-0681	Triple 3-input NAND Gate	5S	74LS10
6	G-6001	8-input NAND Gate	4P	74LS30
7	G-0683	Quad 2-input OR Gate	2C	74LS32
8	G-6002	BCD-to-Decimal Decoder	2J	74LS42
9	53706	Dual D-type Edge-triggered F.F.	2B, 4N, 5P, 5R	74LS74
10	G-0686	Quad 2-input Excl. OR Gate	4J, 4K, 4L, 4M	74LS86
11	G-6003	Divide-by-12 Ripple Counter	5M	74LS92
12	G-0687	Dual J-K Neg. Edge-triggered F.F.	1C	74LS107
13	G-6004	Quad 2-input NOR Buffer	6N	74128
14	G-6005	1-of-8 Decoder/Demultiplexer	5J, 6P	74LS138
15	G-6006	Dual 1-of-4 Decoder/Demultiplexer	2E	74LS139
16	G-0688	8-to-1 Multiplexer	5T	74LS151
17	G-6007	Dual 4-to-1 Multiplexer	7D, 3M	74LS153
18	G-0689	Quad 2-to-1 Multiplexer	3A, 3E, 3F, 3H, 3J, 3K, 3L	74LS157
19	G-6008	Synchronous 4-bit Binary Counter	4T, 4U, 7A, 7B	74LS161
20	G-0691	8-bit Serial in-Parallel out Shift Register	5V, 5W	74LS164
21	G-6009	Hex D-type F.F. with reset	5A, 5B	74LS174
22	G-6010	Quad D-type F.F. with reset	5U, 4W	74LS175
23	G-0692	4-bit Bidirectional Shift Register	4A, 3B	74LS194
24	G-6011	8-to-1 Three-state Multiplexer	6M, 6V	74LS251
25	G-0694	8-bit Addressable Latch	6L	74LS259
26	G-6012	Octal D-type F.F. with reset	3T, 3U	74LS273
27	G-6013	4-bit Adder	4R, 4S	74LS283
28	G-6014	3-state Hex Buffer - 4-bit/2-bit	2F, 2H, 3P, 3R, 3S, 4E, 4F, 4H, 5E, 6A, 6B, 6C	74LS267
29	G-6015	Hex 3-state Inverter 4-bit/2-bit	2V, 2W, 3C, 3D	74LS368
30	G-6016	Octal 3-state F.F.	5D, 5E	74LS374
31	G-0697	Dual Binary Ripple Counter	5K, 5L, 7C	74LS393
32	G-6017	Microprocessor	1F	8080A
33	G-6018	Clock Generator	1D	8224
34	G-6019	Static RAM - 1K X 4	1V, 1W, 5F, 5H, 6F, 6H	2114L
35	G-6020	Quad Analog Switch	7E, 7P	4066
36	52560	Dual Timer	7R	556
37	G-6021	Audio Amplifier	8L	NB3712
38	G-6022	Voltage Ccparator	8N	LM311
39	G-6023	4-terminal Regulator - Positive Adjustable	7T	μA78MTG
40	G-6024	+12-volt Regulator	1R1	7812

GAME P.C. BOARD ASSEMBLY

G-5415-A

ITEM NO.	PART NO.	DESCRIPTION	REF. DES.	MFGR. PART NO.
41	G-6025	-5-volt Regulator	1R2	7905
42	G-6026	Transistor NPN	1R3	C2334
43	49415	Transistor NPN	Q1, Q2	A06
44	G-6028	Transistor NPN	Q3	2SD471
45	G-6029	Transistor NPN	Q4	2SD560
46	G-6030	Silicon Controlled Rectifier	Q7, Q8	2 P1M
47	G-6031	Diode	D1, 3, 4, 5, 6, 7, 17, 18, 19	1S953
48	48214	Diode	D14, 15	
49	52718	Diode - Zener 6.2V	D2	1N4735A
50	46497	Rectifier - Silicon	D8, 9, 10, 11, 12, 13	1N4002
51	51304	8-station Dip Switch - SPST	SW3	
52	G-6035	Trim Pot	VR	10K Ohm
53	G-6036	Crystal - 18.432 MHz	CY	
54	52722	I.C. Socket - 24-pin	1P, 1T, 2M, 2R, 4C	
55	53711	I.C. Socket - 40-pin I.C. PROM - Note Suffixes -2, -3, etc. denote English; -2F French; -2G German; -2S Spanish	1F	
56	G-0961-1	E-PROM	4C	2716
57	G-0960-1	E-PROM	2R	2732
58	G-0960-2	E-PROM	2M	2732
59	G-0960-3	E-PROM	1P	2732
60	G-0961-2	E-PROM	1T	2716
61	G-6037	Heat Sink	H3	
62	G-6038	Insulator		
63	G-6039	Shoulder Washer	1R3	
64	ST-10909	4-40 X 1/2 Pan. Hd. M.S. - Cad.		
65	ST-2540	4-40 X 1/4 Hex. Flg. Whiz Lock - Z.P.		
66	ST-6577	4-40 X 1/4 Pan. Hd. M.S. - Cad.		
67	ST-9430	Washer - Flat fibre	8L	
68	ST-10469	Hex Nut - 4-40 Twin Serr.		
69	53981	Resistor 1/4W 5%	R52, 88	22 Ohm
70	48048	Resistor 3W 10%	R94	22 Ohm
71	53838	Resistor 1/4W 5%	R18, 29, 40, 41, 74	150 Ohm
72	53982	Resistor 1/4W 5%	R28, 39, 51, 63, 75 thru 82	220 Ohm
73	52344	Resistor 1/4W 5%	R53, 64, 65	330 Ohm
74	52377	Resistor 1/4W 5%	R22, 36, 50	390 Ohm
75	49264	Resistor 1/4W 5%	R71, 73, 95, 96	470 Ohm
76	53844	Resistor 1/4W 5%	R21, 35, 49	820 Ohm

GAME P.C. BOARD ASSEMBLY
G-5415-A

ITEM NO.	PART NO.	DESCRIPTION	REF. DES.	MFGR. PART NO.
77	51564	Resistor 1/4W 5%	R3 thru 12, 15, 54, 57, 60, 62, 70, 72, 98, 112, 113	1K Ohm
78	53983	Resistor 1/4W 5%	R20, 34	1.6K Ohm
79	51567	Resistor 1/4W 5%	R2, 84, 104, 107	3.3K Ohm
80	52347	Resistor 1/4W 5%	R83	9.1K Ohm
81	51293	Resistor 1/4W 5%	R1, 89, 90, 105, 108, 110, 111	10K Ohm
82	51291	Resistor 1/4W 5%	R13, 85, 86, 87	22K Ohm
83	49268	Resistor 1/4W 5%	R106, 109	33K Ohm
84	51294	Resistor 1/4W 5%	R14, 92	47K Ohm
85	50966	Resistor 1/4W 5%	R93	100K Ohm
86	53593	Resistor 1/4W 5%	R100	470K Ohm
87	52734	Resistor 1/4W 5%	R99	1M Ohm
88	53975	Resistor 1/2W 5%	R103	1 Ohm
89	53976	Resistor 5W 10T	R101	50 Ohm
90	53977	Resistor 15W 10%	R102	4 Ohm
91	53980	Resistor Dip Pak - Single In-line X 8	RM1	22K Ohm
92	53979	Resistor Dip Pak - Single In-line X 8	RM3	4.7K Ohm
93	53978	Resistor Dip Pak - Single In-line X 8	RM4	1K Ohm
94	52359	Capacitor, Tantalum	C2, 90, 92, 93	1 mf
95	49146	Capacitor, Tantalum	101	
96	52561	Capacitor, Tantalum 15 WVDC	C87	2.2 mf
97	52708	Capacitor, Tantalum 35 WVDC	C95	10 mf
98	48036	Capacitor, Electrolytic 16 WVDC	C116	10 mf
			C19, 21, 34, 49, 51, 56, 58, 63, 65, 69, 72, 76, 109	10 mf
99	46253	Capacitor, Electrolytic	C23, 27	22 mf
100	53985	Capacitor, Electrolytic	C22	33 mf
101	53986	Capacitor, Electrolytic 10 WVDC	C105	47 mf
102	53987	Capacitor, Electrolytic 16 WVDC	C100	47 mf
103	53988	Capacitor, Electrolytic	C107	470 mf
104	53697	Capacitor, Electrolytic	C104	1000 mf
105	53990	Capacitor, Electrolytic	C103	2200 mf
106	53991	Capacitor, Electrolytic	C114, 115	10000 mf
107	53992	Capacitor, Disk	C1	10 pf
108	53993	Capacitor, Disk	C94	.0022 mf
109	53994	Capacitor, Disk	C4, 6, 25, 88, 91, 110, 112, 113	.01 mf
110	53995	Capacitor, Disk 25 WVDC	C98, 99, 108	.1 mf

GAME P.C. BOARD ASSEMBLY
G-5415-A

ITEM NO.	PART NO.	DESCRIPTION	REF. DES.	MFR. PART NO.
111	G-0784	Capacitor, Disk 50 WVDC	C3, 5, 9, 12, 15, 18, 20, 24, 26, 33, 35, 38, 41, 44, 47, 48, 50, 52, 53, 55, 57, 59, 60, 61, 62, 64, 66, 67, 68, 70, 71, 73, 74, 75, 77 thru 86, 89, 96, 97, 102, 111	.1 mf
112	33762	Capacitor, Disk	C118	470 pf

POWER SUPPLY ASSEMBLY

G-5435-A

ITEM NO.	PART NO.	DESCRIPTION
1	G-5440-A G-5449-A	Power Supply Chassis Weld Assembly Power Supply Chassis Weld Assembly - Canada only
2	49250	Shock Safe Fuseholder
3	G-5403-A	Fuseholder Assembly - Canada only
4	ST-9843	Tapered Caplug #5 - Red
5	ST-3090	3A 250V Slo-blo Fuse
6	ST-9631	5A 250V Slo-blo Fuse
7	ST-4367 44930	1.5A Slo-blo Fuse Fusetron - 3.2A - Canada only
8	44935	Snap-in Steel Clip - Canada only
9	ST-9136	Closed-end Connector - Canada only
10	ST-10589	3-circuit Universal Socket Housing
11	ST-10588	4-circuit Universal Socket Housing
12	ST-10570	9-circuit Universal Socket Housing
13	ST-10500	15-circuit Universal Socket Housing
14	ST-10497	Universal Socket (.130)
15	ST-10494	Universal Socket (.200)
16	ST-10558	.250 Insulated Faston Receptacle
17	G-5451-A	Power Transformer Assembly
18	G-5451-CA	Power Transformer Assembly - Canada only
19	ST-10122	Sta-strap
20	G-5357	3-conductor Cord and Plug - Domestic, Canada
21	G-5378-A	3-conductor Cord and Plug - English
22	G-5379	3-conductor SJT Cord - English
23	48577	Plug - fused - English
24	G-5376	Cordset - German, Belgian, French
25	ST-8722	10-32 Hex Flg Whiz Locknut - Z.P.
26	ST-3008-1/2	#5 (.182/.198 I.D.) Tubing - Blue - 1/2"
27	ST-10096	#10 Ring Tongue Terminal
28	ST-10062	8-36 X 5/16 Hex H.M.S. Slotted - Br. Grn. Hd.
29	ST-9650	#8 Ring Tongue Terminal
30	49007	Input Terminal Insulator
31	47827	3-pole Input Terminal - German
32	ST-4518	6-32 X 1/2 Phil. Pan Hd. M.S. - Z.P.
33	ST-8715	6-32 Hex Flg Whiz Locknut - Z.P.
34	ST-10762	Universal Strain Relief
35	ST-9185	Twistum Tie

REPLACEMENT PARTS LIST FOR WELLS-GARDNER COLOR MONITOR

These are Wells-Gardner parts with Wells-Gardner part numbers. Please order these parts from them.

2701 N. Kildare Ave., Chicago, Il. 60639

▲ ★ SAFETY CRITICAL PARTS LIST

This receiver contains circuits and components included specifically for safety purposes. For continued protection no changes should be made to the original design and components shown in shaded areas of schematic, or ▲ ★ on parts list should be replaced with exact factory replacement parts. The use of substitute parts may create a shock, fire, x-radiation or other hazard. Service should be performed by qualified personnel only.

MAIN BOARD (MQ-29)

Ref. No.	Part No.	Description	Ref. No.	Part No.	Description
RESISTORS			CAPACITORS		
R605	203X9014-584	1k Ohm, ± 5%, 1W M.O.	▲ C601	203X1800-451	0.1 uF, 125V, ± 20% MM
R606	204X1425-021	470 Ohm, ± 10%, 5W W.W.	▲ C603	202X7810-214	2200 pF, 125V Ceramic
▲ ★ R607	204X1450-508	2.7k Ohm, ± 10%, 5W W.W.	C608	203X0220-043	330 uF, 200V Electrolytic
R608	203X9014-603	1.2k Ohm, ± 5%, 1W M.O.	C605	203X1205-165	.0068 uF, 600V, ± 10% PP
R610	203X6500-246	22 Ohm, ± 5%, 1/8W Carbon	C607	203X0040-020	10 uF, 160V Electrolytic
R611	203X6700-562	1k Ohm, ± 5%, 1/2W Carbon	C608	203X0040-052	47 uF, 160V Electrolytic
R612	340X3471-944	470 Ohm, ± 10%, 1/2W Carbon	C609	202X7050-366	.0033 uF, 500V, ± 10% Ceramic
R613	203X9010-757	1.2k Ohm, ± 5%, 1W M.O.	C610	202X7050-483	100 pF, 3KV, ± 10% Ceramic
R614	203X5202-320	680k Ohm, ± 5%, 1/2W Comp.	C611	202X8140-022	.022 uF, 200V, ± 10% PP
R615	203X5602-156	270k Ohm, ± 5%, 1/2W Comp.	C612	203X1201-047	220 uF, 25V Electrolytic
R616	203X6500-741	2.7k Ohm, ± 5%, 1/8W Carbon	C613	203X0015-035	33 uF, 25V Electrolytic
R617	203X6501-088	68k Ohm, ± 5%, 1/8W Carbon	C614	203X0015-006	0.39 uF, 200V, ± 10% PP
R620	203X6500-508	270 Ohm, ± 5%, 1/8W Carbon	C615	203X1201-288	47 pF, 500V Ceramic
R622	203X6500-689	1.5k Ohm, ± 5%, 1/8W Carbon	C616	202X8065-499	1 uF, 50V Electrolytic
R624	203X6205-843	1k Ohm, ± 5%, 1/2W Carbon	C617	203X0025-019	82 pF, 50V, ± 5% Ceramic
R630	203X5601-906	68k Ohm, ± 5%, 1/2W Carbon	C618	202X8000-577	1 uF, 50V Electrolytic
R631	203X9015-087	2.2 Ohm, ± 10%, 5W M.O.	C619	203X0025-019	0.1 uF, 100V, ± 10% Mylar
R632	340X8111-731	110 Ohm, ± 5%, 5W Carbon	C620	203X1107-038	0.1 uF, 1.5KV, ± 20% Paper
R632	340X8121-731	120 Ohm, ± 5%, 5W Carbon	C621	202X9040-155	1000 uF, 35V Electrolytic
R634	203X6000-002	2.2 Ohm, ± 5%, 1/8W Carbon	C622	203X0020-099	470 uF, 25V Electrolytic
R635	203X9014-842	12k Ohm, ± 5%, 1W M.O.	C623	203X0015-053	100 uF, 25V Electrolytic
R636	203X6500-645	1k Ohm, ± 5%, 1/8W Carbon	C624	203X0015-021	10 uF, 160V Electrolytic
R640	203X6500-762	3.3k Ohm, ± 5%, 1/8W Carbon	C625	203X0040-020	100 pF, 500V, ± 10% Ceramic
R641	203X6501-002	33k Ohm, ± 5%, 1/8W Carbon	C626	202X7050-009	39 pF, 500V, ± 10% Ceramic
R642	203X6500-927	15k Ohm, ± 5%, 1/8W Carbon	C627	202X8065-461	2200 pF, 50V, ± 10% Ceramic
R643	203X5602-648	3.9M Ohm, ± 5%, 1/2W Comp.	C628	202X7000-327	6900 pF, 1.5KV, ± 5% PP
R646	203X6500-468	180 Ohm, ± 5%, 1/8W Carbon	★ C629	203X1270-470	2200 pF, 125V Ceramic
R647	340X5150-841	15 Ohm, ± 10%, 2W Carbon	C630	202X7810-214	470 uF, 6.3V Electrolytic
R648	340X2225-934	2.2M Ohm ± 5%, 1/4W Carbon	C632	203X0005-029	2.2 uF, 50V Electrolytic
			C633	203X0315-033	6 pF, 50V, ± 0.5 pF Ceramic
			C634	202X8000-164	3 pF, 2 kV, ± 0.5 pF Ceramic
			C637	202X8105-014	.056 uF, 10% Mylar
			C638	342X5632-040	
*For Model K4603 Only					
SEMICONDUCTORS			MISCELLANEOUS		
TR601	200X3189-304	Transistor, 2SC1893	▲ F601	204X7120-062	Fuse (UL/CSA) 3A-125
X601	201X3130-109	Rectifier, (SI) RM-2AV 600V	J607	206X5003-960	Socket, 6 Pin
X605	200X8130-171	Diode (HS) SB-2CGL 1200V min.	P602	204X9600-260	Plug, 3 Pin (GT)
X606	201X2010-144	Diode (SI) IS2473-772	P603	204X9600-254	Plug, 3 Pin (NM)
X607	201X2100-119	Diode (HS) RC-2V 0.8 US	P604	204X9600-298	Plug, 4 Pin (NM)
X608	201X2130-234	Diode (HS) RU-2V	P606	204X9600-351	Plug, 6 Pin (NM)
X609	201X2130-234	Diode (HS) RU-2V	P607	204X9600-380	Plug, 6 Pin (GT)
X610	66X0023-009	Rectifier, Power (SI) 500V PIV	P608	204X9600-254	Plug, 3 Pin (NM)
X611	66X0023-009	Rectifier, Power (SI) 500V PIV	P610	204X9600-249	Plug, 2 Pin (GT)
			P611	204X9600-670	Plug, 2 Pin (NM)
			TH601	201X011-034	Thermistor
			TH602	201X022-007	Varistor
TRANSFORMERS & COILS					
▲ L601	201X6000-112	Coil, Line Filter R-3			
L602	201X4600-042	Coil, Filter, 10 uH			
L603	201X4100-024	Coil, Peaking, 22 uH			
L607	201X4710-134	Coil, R-F Choke			
T601	201X9500-337	Transformer, Audio Output			
T602	201X1300-080	Transformer, Hor. Drive			
T603	202X1210-191	Transformer, Side PC			
L702	9A2795-001	Horiz. Size			

VERT/HOR BOARD (MT/QJ)

WELLS-GARDNER PARTS...ORDER FROM THEM...SEE PAGE 6-9

Ref. No.	Part No.	Description	Ref. No.	Part No.	Description
RESISTORS			CAPACITORS (CONT.)		
R301	203X6500-628	820 Ohm, ± 5%, 1/8W Carbon	C313	203X0025-087	47 uF, 50V Electrolytic
R302	203X6500-902	12k Ohm, ± 5%, 1/8W Carbon	C315	203X0015-082	10 uF, 25V Electrolytic
R303	203X6500-927	15k Ohm, ± 5%, 1/8W Carbon	C316	203X1100-220	3300 uF, 50V, ± 10% Mylar
R304	203X6500-886	10k Ohm, ± 5%, 1/8W Carbon	C317	202X8000-616	100 pF, 50V, ± 10% Ceramic
R305	203X6501-241	330k Ohm, ± 5%, 1/8W Carbon	C351	202X7000-281	1500 pF, 50V, ± 10% Ceramic
R306	203X6500-645	1k Ohm, ± 5%, 1/8W Carbon	C352	202X7000-247	1000 pF, 50V, ± 10% Ceramic
R307	203X6500-689	1.5k Ohm, ± 5%, 1/8W Carbon	C353	203X1100-573	0.022 uF, 50V, ± 10% Mylar
R309	203X6500-724	2.2k Ohm, ± 5%, 1/8W Carbon	C355	203X1100-858	0.1 uF, 50V, ± 10% Mylar
R310	203X6501-285	470k Ohm, ± 5%, 1/8W Carbon	C356	203X0015-105	4.7 uF, 25V Electrolytic
R311	203X6501-065	56k Ohm, ± 5%, 1/8W Carbon	C357	203X1201-013	0.015uF, 200V ± 10% PP
R312	203X6501-126	100k Ohm, ± 5%, 1/8W Carbon	C358	203X1201-034	0.018 uF, 200V, ± 10% PP
R313	203X6001-326	10k Ohm, ± 5%, 1/8W Carbon	C359	203X0040-013	4.7 uF, 160V Electrolytic
R314	203X6501-044	47k Ohm, ± 5%, 1/8W Carbon	C360	202X7000-482	0.01 uF, 50V, ± 10% Ceramic
R315	203X6500-628	820 Ohm, ± 5%, 1/8W Carbon	C361	203X1100-509	0.015 uF, 50V, ± 10% Mylar
R316	203X6500-420	120 Ohm, ± 5%, 1/8W Carbon	C362	203X0025-058	10 uF, 50V Electrolytic
R317	203X6206-441	2.2 Ohm, ± 5%, 1/2W Carbon	C363	203X1205-487	0.01 uF, 630V, ± 10% PP
R319	203X6500-169	100 Ohm, ± 5%, 1/8W Carbon	C364	202X7000-482	0.01 uF, 50V, ± 10% Ceramic
R320	203X6500-927	15k Ohm, ± 5%, 1/8W Carbon			
R321	203X6700-509	560 Ohm, ± 5%, 1/2W Carbon			
R322	203X9100-121	22 Ohm, ± 5%, 2W M.O.			
R323	203X6500-689	1.5k Ohm, ± 5%, 1/8W Carbon			
R324	203X6500-988	27k Ohm, ± 5%, 1/8W Carbon	TR301	200X4082-614	Transistor, 2SA826Q
R325	203X6500-326	47 Ohm, ± 5%, 1/8W Carbon	TR302	200X3174-006	Transistor, 2SC1740Q
R328	203X6500-628	820 Ohm, ± 5%, 1/8W Carbon	TR303	200X3174-006	Transistor, 2SA1740Q
R330	203X6500-886	10k Ohm, ± 5%, 1/8W Carbon	TR304	200X3174-006	Transistor, 2SC1740Q
R331	203X6501-209	220k Ohm, ± 5%, 1/8W Carbon	TR305	200X4049-081	Transistor, 2SA490YLBGLI
R351	203X6500-724	2.2k Ohm, ± 5%, 1/8W Carbon	TR306	200X3162-538	Transistor, 2SC1625YLBGLI
R352	203X6500-927	15k Ohm, ± 5%, 1/8W Carbon	TR307	200X3174-014	Transistor, 2SC1740R
R353	203X6500-944	18k Ohm, ± 5%, 1/8W Carbon	TR308	200X3174-006	Transistor, 2SC1740Q
R354	203X6500-783	3.9k Ohm, ± 5%, 1/8W Carbon	TR351	200X4085-415	Transistor, 2SA854Q
R355	203X6500-902	12k Ohm, ± 5%, 1/8W Carbon	TR352	200X3172-208	Transistor, 2SC1722BKS
R356	203X6500-561	470 Ohm, ± 5%, 1/8W Carbon	TR353	200X3174-006	Transistor, 2SC1740Q
R357	203X6500-724	2.2k Ohm, ± 5%, 1/8W Carbon	TR354	200X4082-614	Transistor, 2SA826Q
R358	203X6500-666	1.2k Ohm, ± 5%, 1/8W Carbon	X301	201X2010-144	Diode, (SI) IS2473-T72
R359	203X6501-088	68k Ohm, ± 5%, 1/8W Carbon	X302	201X2010-144	Diode, (SI) IS2473-T72
R360	203X5500-471	27 Ohm, ± 5%, 1/4W Comp.	X303	200X8000-026	Diode, (GE), IN60TVGL
R361	203X6000-998	1.2k Ohm, ± 5%, 1/8W Carbon	X304	200X8010-165	Diode (SI) ISS81
R363	203X6500-666	1.2k Ohm, ± 5%, 1/8W Carbon	X305	201X2010-165	Diode (SI) ISS81
R364	203X9014-988	47k Ohm, ± 5%, 1W M.O.	X306	201X2010-165	Diode (SI) ISS81
R365	203X6700-989	56k Ohm, ± 5%, 1/2W Carbon	X307	200X8010-102	Diode (SI) MA26W
R366	203X6001-148	3.3k Ohm, ± 5%, 1/8W Carbon	X308	200X8010-094	Diode (SI) IS2473
R367	340X2222-734	2.2k Ohm, ± 5%, 1/2W Carbon	X351	201X2010-144	Diode (SI) IS2473-T72
R368	203X6500-785	3.9k Ohm, ± 5%, 1/8W Carbon	X352	201X2010-144	Diode (SI) IS2473-T72
R369	203X6500-762	3.3k Ohm, ± 5%, 1/4W Carbon	X353	201X2010-144	Diode (SI) IS2473-T72
R370	302X6100-961	1k Ohm, ± 5%, 1/4W Carbon	X354	201X2010-144	Diode (SI) IS2473-T72
R371	203X6104-751	2.7k Ohm, ± 5%, 1/4W Carbon	X355	200X8220-851	Diode (Zener) RD10EBI
VR301	204X2122-093	Varistor, 250K Ohm, Vert. Hold	X366	200X8100-130	Diode (HS) RU-1 0.3 US
VR302	204X2114-065	Varistor, 20K Ohm, Vert. Size			
VR351	204X2114-059	Varistor, 50K Ohm, Hor. Hold			
CAPACITORS			MISCELLANEOUS		
C301	203X1100-928	0.15 uF, 50V, ± 10% Mylar	J301	204X9300-958	Socket, 6 Pin
C302	203X1100-573	0.022 uF, 50V, ± 10% Mylar	J302	204X9300-958	Socket, 6 Pin
C304	203X1100-858	0.1 uF, 50V, ± 10% Mylar	P301	204X9601-195	Plug, 6 Pin
C306	203X0025-026	2.2 uF, 50V, Electrolytic	P302	204X9601-195	Plug, 6 Pin
C307	203X1100-928	0.15 uF, 50V, ± 10% Mylar	TH301	201X0000-534	Thermistor
C309	203X1100-858	0.1 uF, 50V, ± 10% Mylar			
C310	203X0010-011	22 uF, 16V Electrolytic			
C311	203X0020-099	1000 uF, 35V Electrolytic			
C312	202X7000-469	0.0082 uF, 50V, ± 10% Ceramic	L351	201X5200-091	Coil, Horiz. Osc.
POWER BOARD (MV)			TRANSFORMERS & COILS		
RESISTORS			C503	203X0010-011	22 uF, 16V Electrolytic
			C551	203X0005-046	220 uF, 10V Electrolytic
R501	204X1725-052	180 Ohm, ± 10%, 15W WW			
R502	203X6000-608	100 Ohm, ± 5%, 1/8W Carbon			
R503	203X6000-960	1k Ohm, ± 5%, 1/8W Carbon			
R504	203X6000-879	560 Ohm, ± 5%, 1/8W Carbon	TR501	200X3174-006	Transistor, 2SC1740Q
R505	203X9014-965	39k Ohm, ± 5%, 1W M.O.	★TR502	200X3145-404	Transistor, 2SC1454
R506	203X6500-842	6.8k Ohm, ± 5%, 1/8W Carbon	TR551	200X3172-305	Transistor, 2SC1723
R551	203X6500-420	120 Ohm, ± 5%, 1/8W Carbon	X501	201X2230-042	Diode, (SI) Zener EQB01-06V
VR501	204X2050-001	Varistor Vert. Adj.	X502	201X2010-144	Diode, (SI) IS2473-T72
CAPACITORS			MISCELLANEOUS		
C501	203X0040-020	10 uF, 160V Electrolytic	J501	204X9300-958	Socket, 6 Pin
C502	202X7000-281	1500 pF, 50V, ± 10% Ceramic	P501	204X9601-195	Plug, 6 Pin
			TH501	201X0000-618	Thermistor

NECK BOARD (MS/QG)

WELLS-GARDNER PARTS...ORDER FROM THEM...SEE PAGE 6-9

Ref. No.	Part No.	Description	Ref. No.	Part No.	Description
----------	----------	-------------	----------	----------	-------------

RESISTORS

R401	203X6500-709	1.8k Ohm ± 5% 1/8W Carbon
R402	203X6500-709	1.8k Ohm ± 5% 1/8W Carbon
R403	203X6500-709	1.8k Ohm ± 5% 1/8W Carbon
R404	203X6500-447	150 Ohm ± 5% 1/8W Carbon
R405	203X6500-481	220 Ohm ± 5% 1/8W Carbon
R406	203X6500-447	150 Ohm ± 5% 1/8W Carbon
R407	203X6500-508	270 Ohm ± 5% 1/8W Carbon
R408	203X6500-508	270 Ohm ± 5% 1/8W Carbon
R409	203X6500-800	4.7k Ohm ± 5% 1/8W Carbon
R410	203X6500-800	4.7k Ohm ± 5% 1/8W Carbon
R411	203X6500-800	4.7k Ohm ± 5% 1/8W Carbon
R412	203X9104-809	12k Ohm ± 5% 2.0W Metal Oxide
R413	203X9104-809	12k Ohm ± 5% 2.0W Metal Oxide
R414	203X9104-809	12k Ohm ± 5% 2.0W Metal Oxide
R415	203X5601-313	2.7k Ohm ± 10% 1/2W Comp.
R416	203X5601-313	2.7k Ohm ± 10% 1/2W Comp.
R417	203X5601-313	2.7k Ohm ± 10% 1/2W Comp.
R418	203X5602-254	470k Ohm ± 10% 1/2W Comp.
R419	203X5602-185	330k Ohm ± 10% 1/2W Comp.
R422	203X9105-117	1.0 Ohm ± 10% 2W Metal Oxide
R423	203X5102-155	270k Ohm ± 5% 1/4W Carbon
VR401	204X2115-014	500 Ohm Varistor R Drive
VR402	204X2115-014	500 Ohm Varistor B Drive
VR403	204X2115-006	5k Ohm Varistor R Cutoff
VR404	204X2115-006	5k Ohm Varistor G Cutoff
VR405	204X2115-006	5k Ohm Varistor B Cutoff
VR406	204X2000-025	1M Ohm Varistor Screen

C403	202X7000-247	1000 pF, 50V, 10% Ceramic
C404	202X7110-019	1500 pF, 2kV ± 10% Ceramic
C405	202X7150-018	100 pF, 12kV, ± 10% Ceramic
C406	202X7050-483	.01 uF, 500V, ± 10% Ceramic
C407	202X7110-019	1500 pF, 2kV ± 10% Ceramic
C408	202X8000-550	68 pF, 50V, ± 10% Ceramic
C409	202X8000-550	68 pF, 50V, ± 10% Ceramic
C410	202X8000-550	68 pF, 50V, ± 10% Ceramic

SEMICONDUCTORS

TR401	200X3206-800	Transistor, 2SC2068, 2SC1514 (R output)
TR402	200X3206-800	Transistor, 2SC2068, 2SC1514 (G output)
TR403	200X3206-800	Transistor, 2SC2068, 2SC1514 (B output)
X404	201X2100-126	Diode, IS2367 (protector)
X405	201X2100-126	Diode, IS2367 (protector)
X406	201X2100-126	Diode, IS2367 (protector)

MISCELLANEOUS

C401	202X7000-247	1000 pF, 50V, 10% Ceramic	J401	206X5003-729	Socket, 5 Pin
C402	202X7000-247	1000 pF, 50V, 10% Ceramic	J402	206X5003-983	Socket, 3 Pin
			P401	204X9600-329	Plug, 5 Pin
			P402	204X9600-254	Plug, 3 Pin

△★ 297X2000-072 HIGH VOLTAGE ASSEMBLY (T701)

△★ R701	204X1625-058	3.3 Ohm, ± 10% 10W WW Resistor
VR702	204X3901-125	Focus Control
X701		Diode (SI HV) } Part of T701
X702		Diode (SI HV) }
X703		Diode (SI HV) }

FINAL ASSEMBLY PARTS

△★ 88X-0129-506	19VJTP22 Pix Tube
38A5554-000	Assy. Purity Shld/Degaussing
205X9800-256	Lateral/Purity Assembly
△★ 202X1110-810	Yoke, Deflection
208X2000-946	CRT Socket
297X2000-072	HV Unit (T701)
6A0397	Plug, Line Cord
9A2753-003	Degaussing Coil (L701)

INTERFACE BOARD

MODEL K4677

WELLS-GARDNER PARTS...ORDER FROM THEM...SEE PAGE 6-9

Ref. No.	Part No.	Description	Ref. No.	Part No.	Description
RESISTORS			CAPACITORS		
R201	340X3910-934	1/2W 5% 91 Ohm	C201	45X0524-038	16V 1000mf
R202	340X2223-934	1/4W 5% 22K Ohm	C202	45X0524-053	16V 470mf
R203	340X3102-934	1/2W 5% 1K Ohm	C203	349X2232-109	100V .022mf
R204	340X2101-934	1/4W 5% 100 Ohm	C204	80X0099-020	680pf
R205	340X2104-934	1/4W 5% 100K Ohm	SEMICONDUCTORS		
R206	340X3331-944	1/2W 10% 330 Ohm	TR201	86X0113-001	Transistor NPN
R207	340X2222-934	1/4W 5% 2.2K Ohm	TR202	86X0113-001	Transistor NPN
R208	340X2222-934	1/4W 5% 2.2K Ohm	TR203	86X0113-001	Transistor NPN
R209	340X2104-934	1/4W 5% 100K Ohm	TR204	86X0066-001	Transistor PNP
R210	340X2101-934	1/4W 5% 100 Ohm	TR205	86X0066-001	Transistor PNP
R211	340X2201-934	1/4W 5% 200 Ohm	TR206	86X0066-001	Transistor PNP
R212	340X2201-934	1/4W 5% 200 Ohm	TR207	86X0113-001	Transistor NPN
R213	340X2201-934	1/4W 5% 200 Ohm	TR208	86X0113-001	Transistor NPN
R214	340X2201-934	1/4W 5% 200 Ohm	TR209	86X0113-001	Transistor NPN
R215	340X2201-934	1/4W 5% 200 Ohm	TR210	86X0113-001	Transistor NPN
R216	340X2201-934	1/4W 5% 200 Ohm	X201	66X0046-001	Diode, Silicon
R217	340X2101-934	1/4W 5% 100 Ohm	X202	66X0046-001	Diode, Silicon
R218	340X3102-934	1/4W 5% 1K Ohm	X203	66X0046-001	Diode, Silicon
R219	340X3102-934	1/2W 5% 1K Ohm	X204	66X0046-001	Diode, Silicon
R220	340X3631-934	1/2W 5% 680 Ohm	ZD201	66X0040-019	Diode, Zener
R221	340X3471-934	1/2W 5% 470 Ohm	MISCELLANEOUS		
R222	340X2201-934	1/4W 5% 200 Ohm	J201	204X9300-958	Socket, 6 Pin
R223	340X2104-934	1/4W 5% 100K Ohm	J202	204X9300-958	Socket, 6 Pin
R224	340X3102-934	1/2W 5% 1K Ohm	J203	206X5019-207	Socket, 4 Pin
R225	340X2822-934	1/2W 5% 8.2K Ohm	P201	204X9601-195	Plug, 6 Pin
R226	340X2822-934	1/2W 5% 8.2K Ohm	P202	204X9601-195	Plug, 6 Pin
R227	340X2822-934	1/2W 5% 8.2K Ohm	P203	204X9600-845	Plug, 4 Pin
			P204	6A393-003	Plug, 3 Pin
			P205	6A0393-006	Plug, 6 Pin

APPENDIX A

Assembly Drawings
Schematics
and
Wiring Diagrams

P.C. BOARD LAYOUT

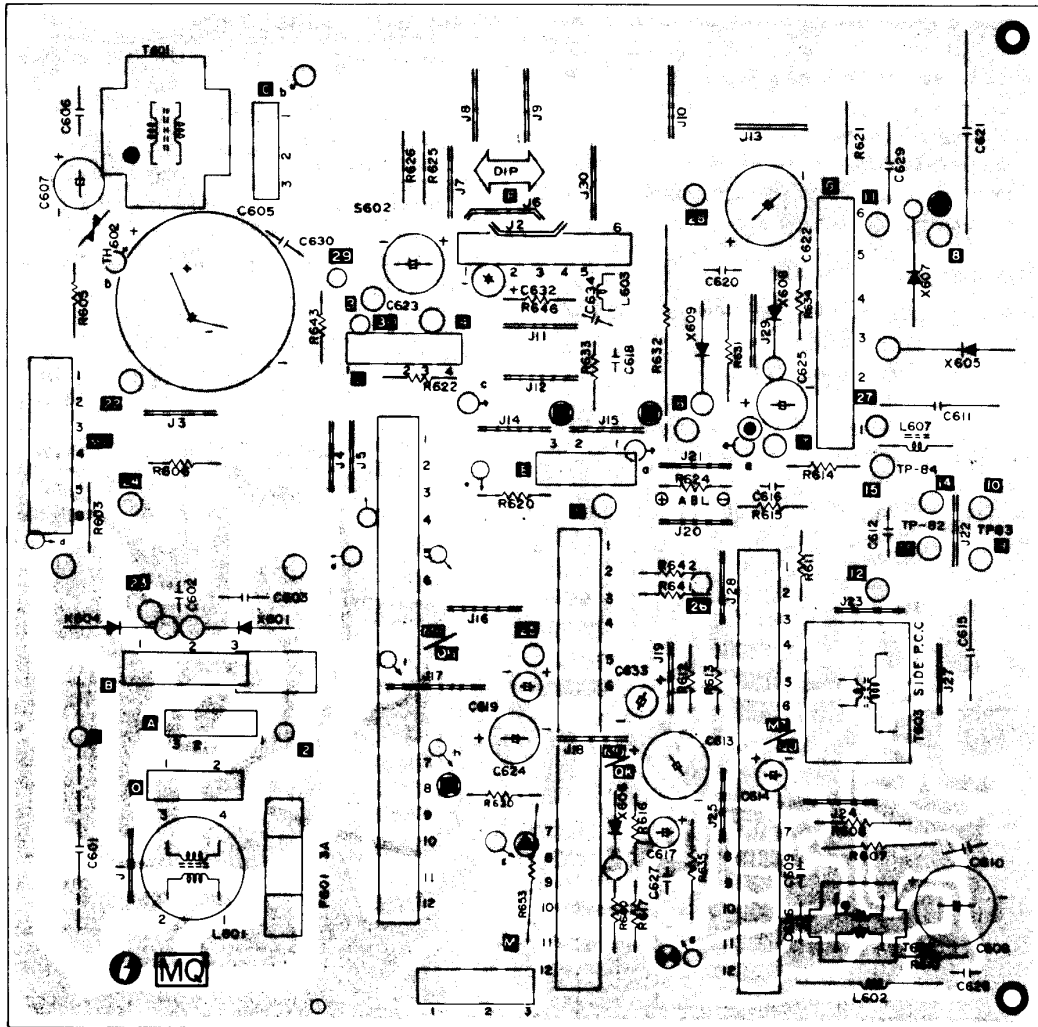

FIGURE 14. MAIN P.C. BOARD MQ-29

P.C. BOARD LAYOUT

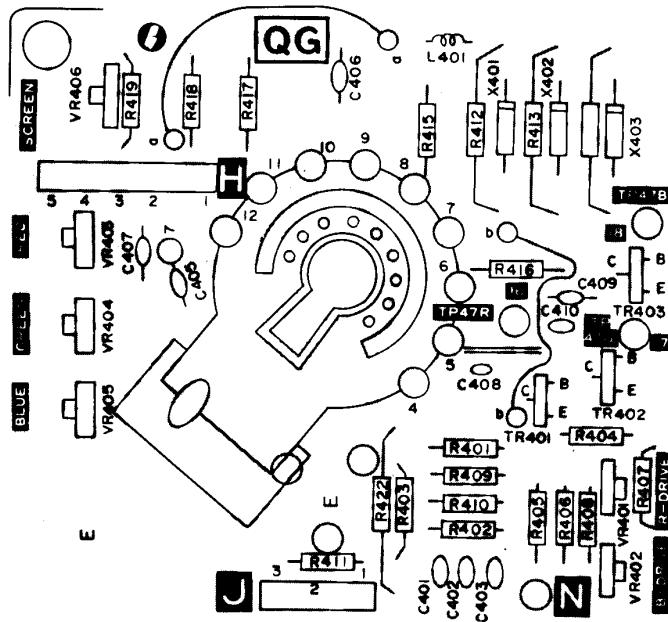

FIGURE 15. NECK P.C. BOARD MS/QG

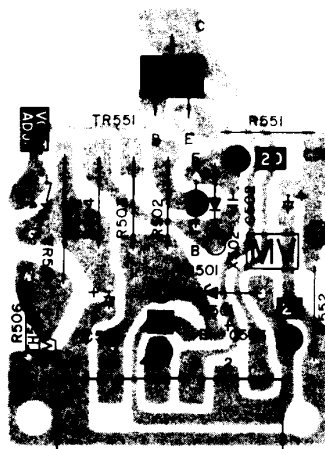

FIGURE 16. POWER PC BOARD MV

P.C. BOARD LAYOUT

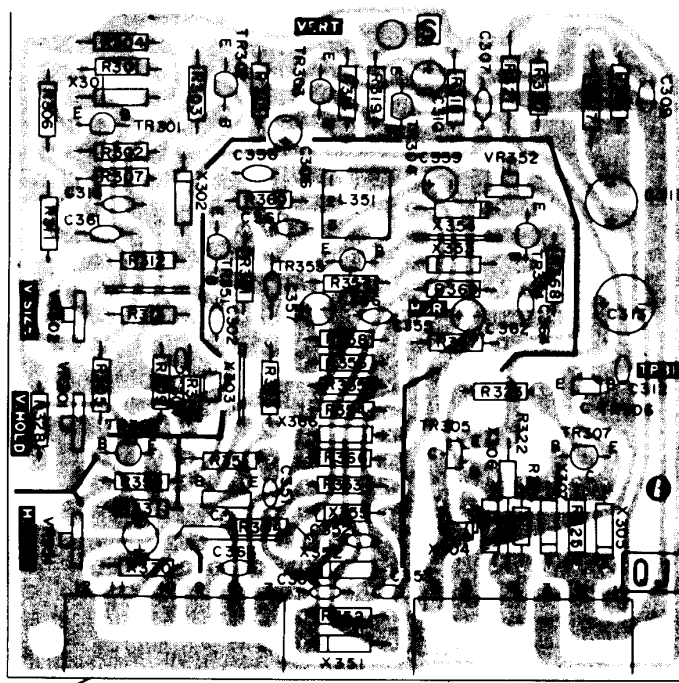
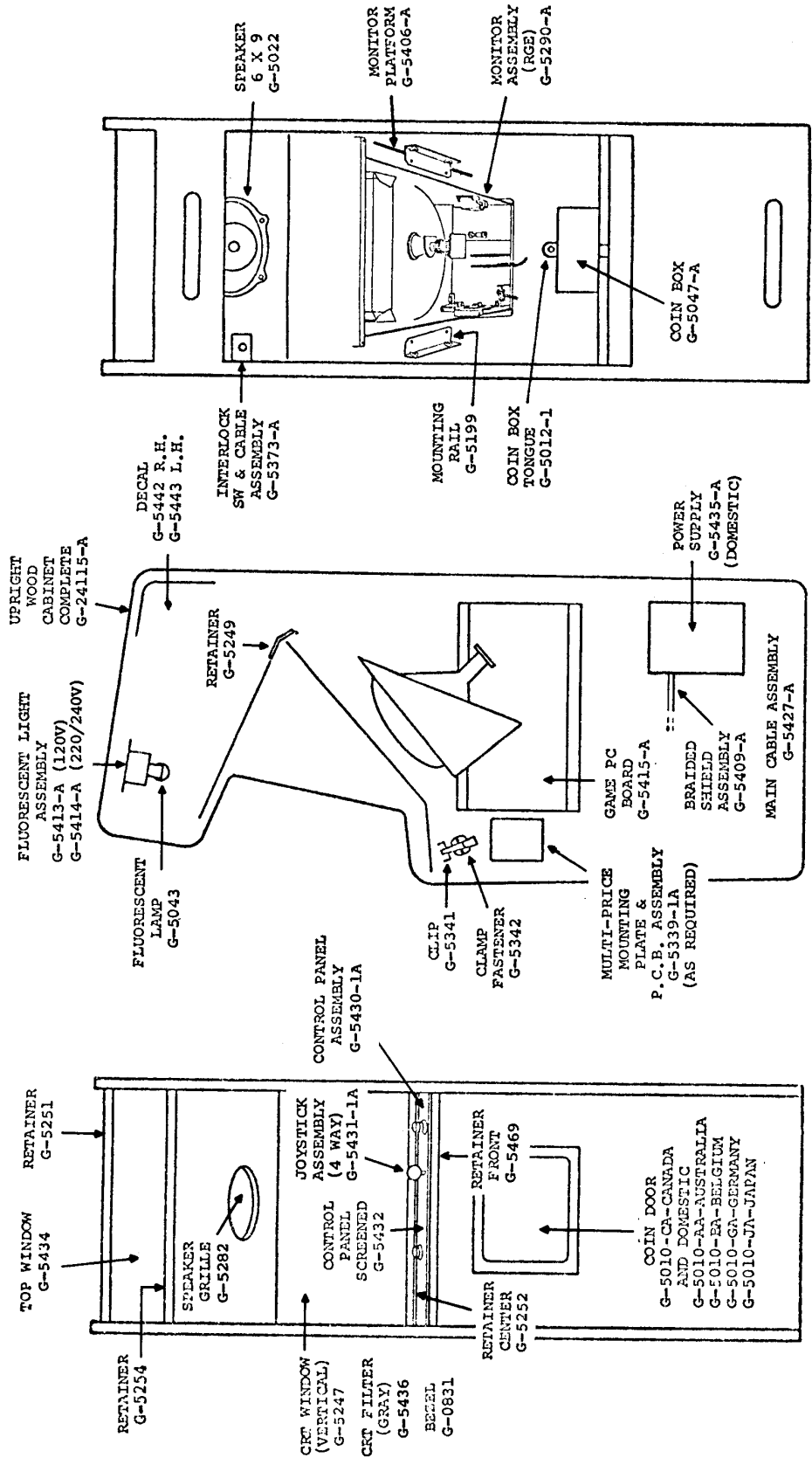
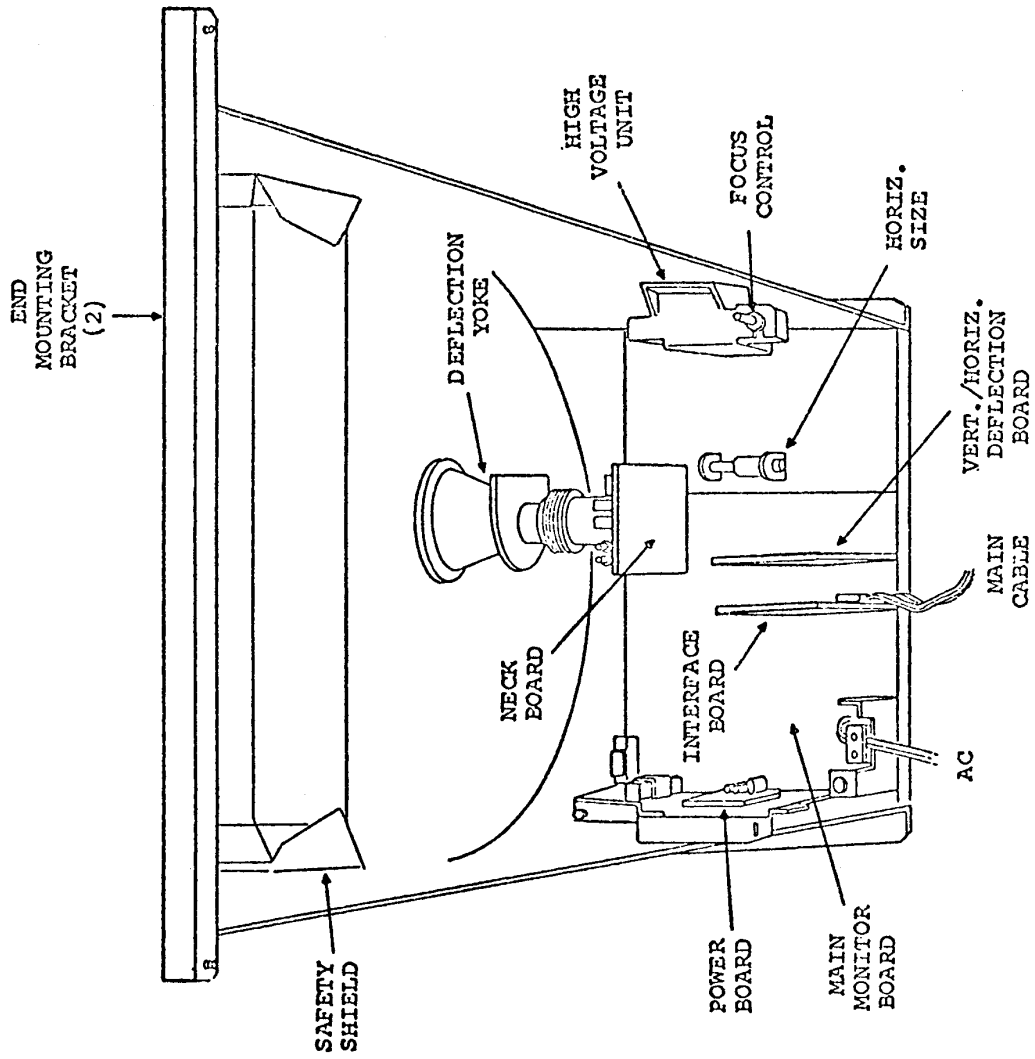

FIGURE 17. HORIZVERT P.C. BOARD [MT/QJ]



G-201
CABINET PARTS



WELLS-GARDNER MONITOR ASSEMBLY

POWER SUPPLY VOLTAGE OPTION & MAIN SWITCH SOCKET

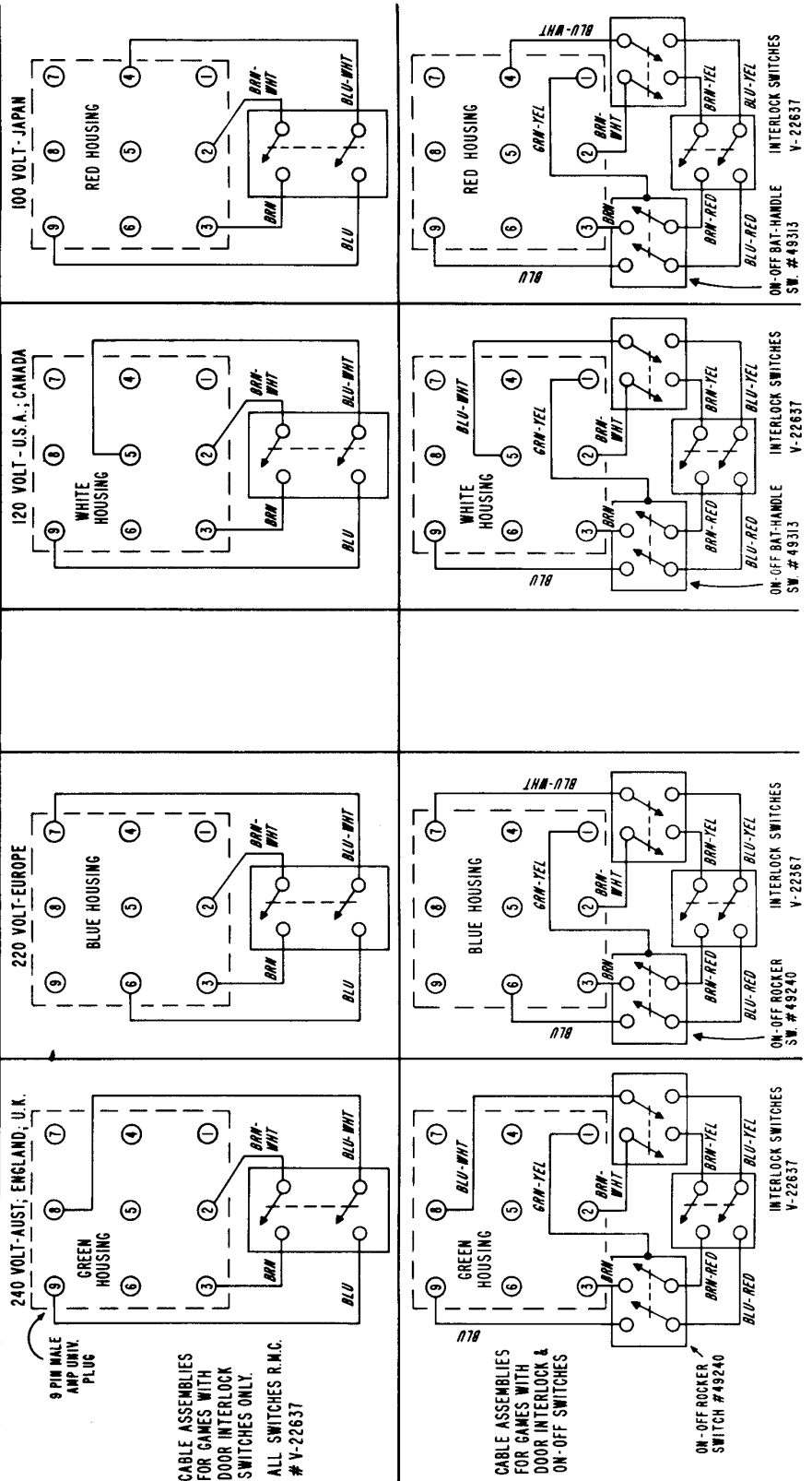
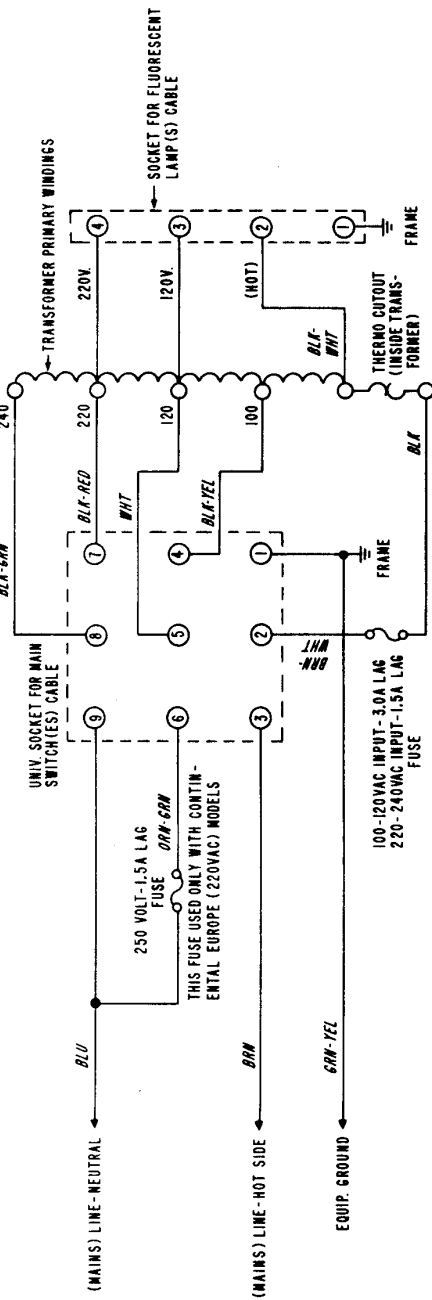

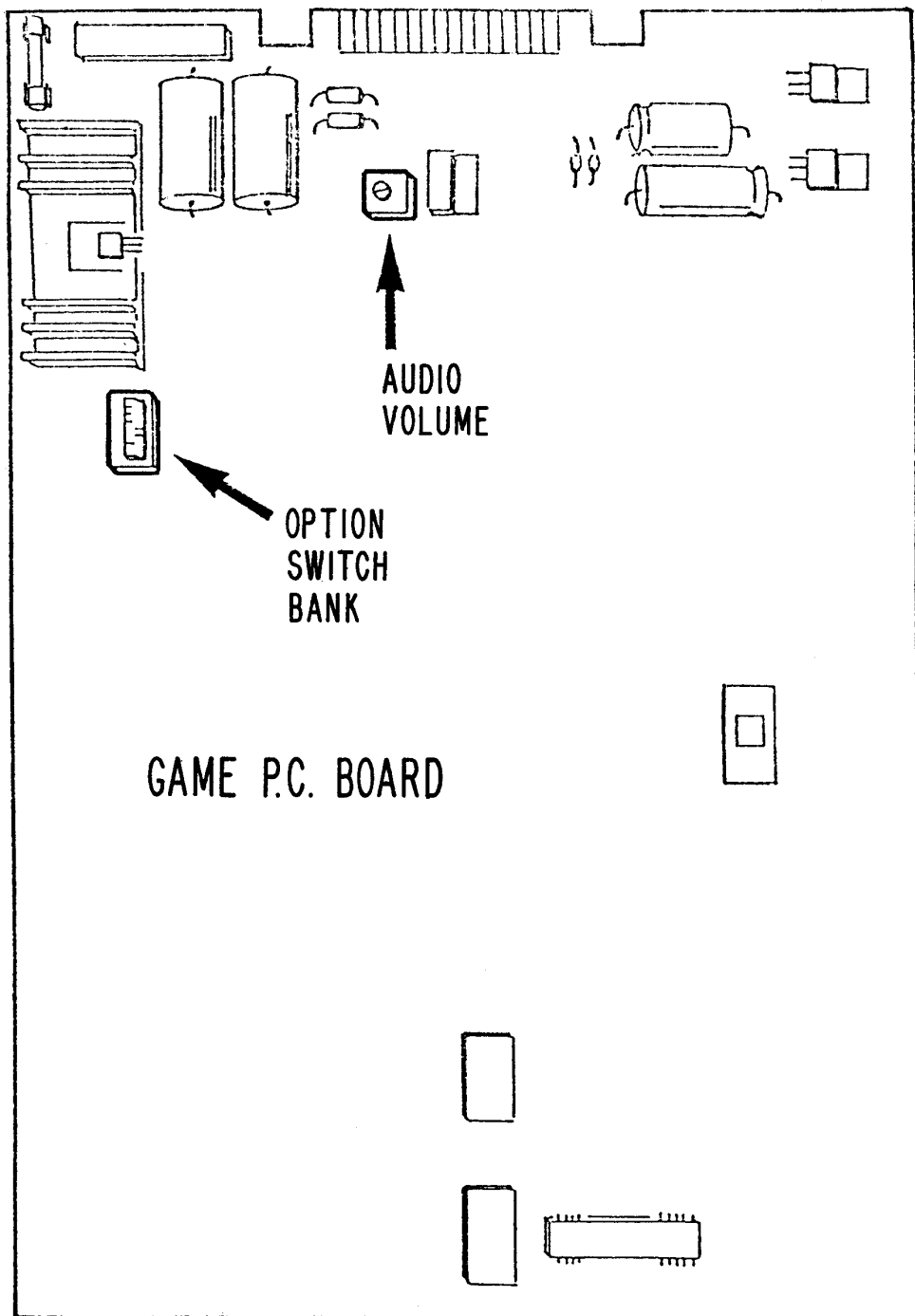

POWER-UP PROTECTION P.C.B. ASSEMBLY

G-6050-A
G-6050-1A

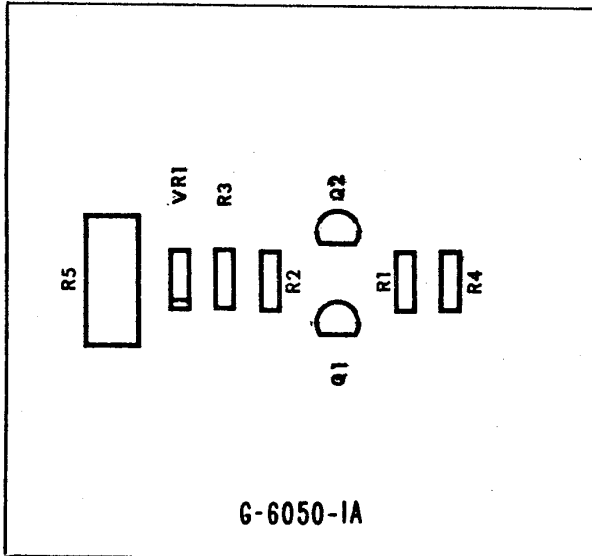

ITEM	PART NO.	DESCRIPTION
RESISTORS		
R1	53981	22 Ohm 1/4W 5%
R2	51564	1K Ohm 1/4W 5%
R3	51289	100 Ohm 1/4W 5%
R4	51564	1K Ohm 1/4W 5%
R5	35326	220 Ohm 1W 5%
DIODE		
VR1	51982	Diode, Zener 10V 1W IN4740-A
TRANSISTORS		
Q1	49415	NPS-A06 (NPN)
Q2	49415	MPS-A06 (NPN)
MISCELLANEOUS		
J1	ST-10572	4-Circuit Right Angle Pin Header
	G-6049	Power-up Protection P.C. Board
	49252	Plastic Board Support
	ST-10571	4-Circuit C.I.S. Housing
	53717	4-Circuit P.C.B. Edge Connector
	ST-6688	20-Str Red Wire-23"
	ST-6603	20-Str Black Wire-25"
	ST-8902	20-Str Grn/Wht Wire-12 1/2"
	ST-10691	C.I.S. Contact
	46733-1	P.C.B. Contact
	ST-10604	Cable Clip

Check whether you have the G-6050-A or the G-6050-1A Board. They are not interchangeable. The G-6050-1A Board has these differences: It does not include J1; G-6049-1 replaces G-6049; 53717 replaces ST-10571; 46733-1 replaces ST-10691.

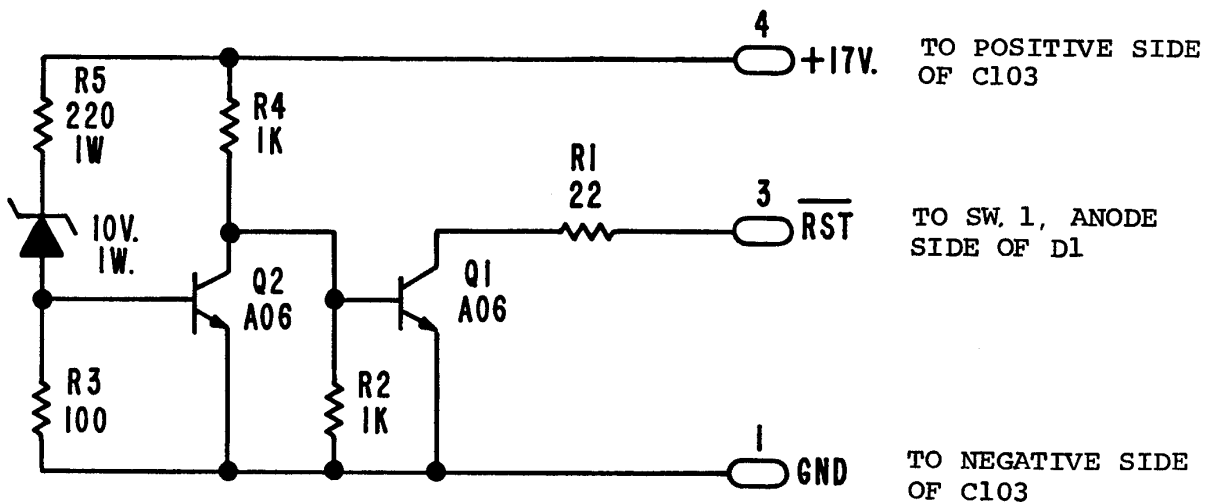

JOYSTICK SWITCH ADJUSTMENTS

1. Adjust each individual switch as follows:
 - 1.1 Loosen front screw on switch bracket.
 - 1.2 Move cam as far as possible toward switch & hold in this position.
 - 1.3 Rotate switch toward cam until switch contacts close.
 - 1.4 Continue to rotate switch until top blade deflects approx. 1/16" as shown below.
 - 1.5 Lock front screw on bracket.
2. After adjusting all four switches, move lever against side of square and check switch action -
 - 2.1 Switch #1 must break before switch #2 makes. No two switches can make contact at the same time or game action will be erratic.

MOVE SWITCH UNTIL CONTACTS MAKE - CONTINUE TO DEFLECT TOP BLADE 1/16"

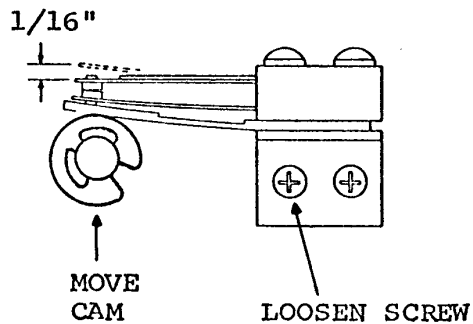

CHECK FOUR SWITCHES FOR CONTACT ADJUSTMENT

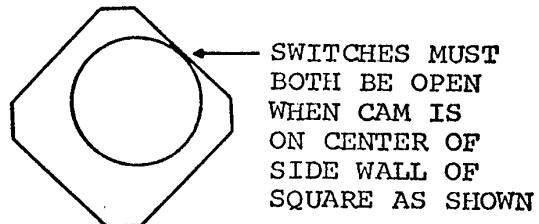
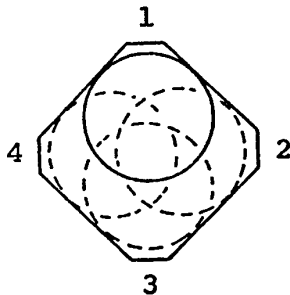

3. **IMPORTANT:** TIGHTEN ALL SCREWS on switch brackets to prevent any movement after adjusting.

ROCK-OLA GAME P.C.B. SCHEMATIC DIAGRAM SHEET 1 OF 4 C.P.U. ROM RAM

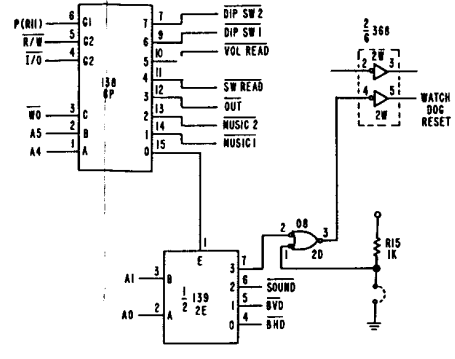
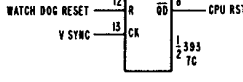
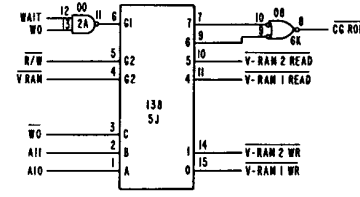
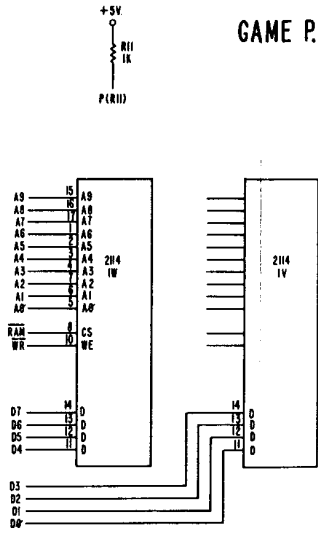
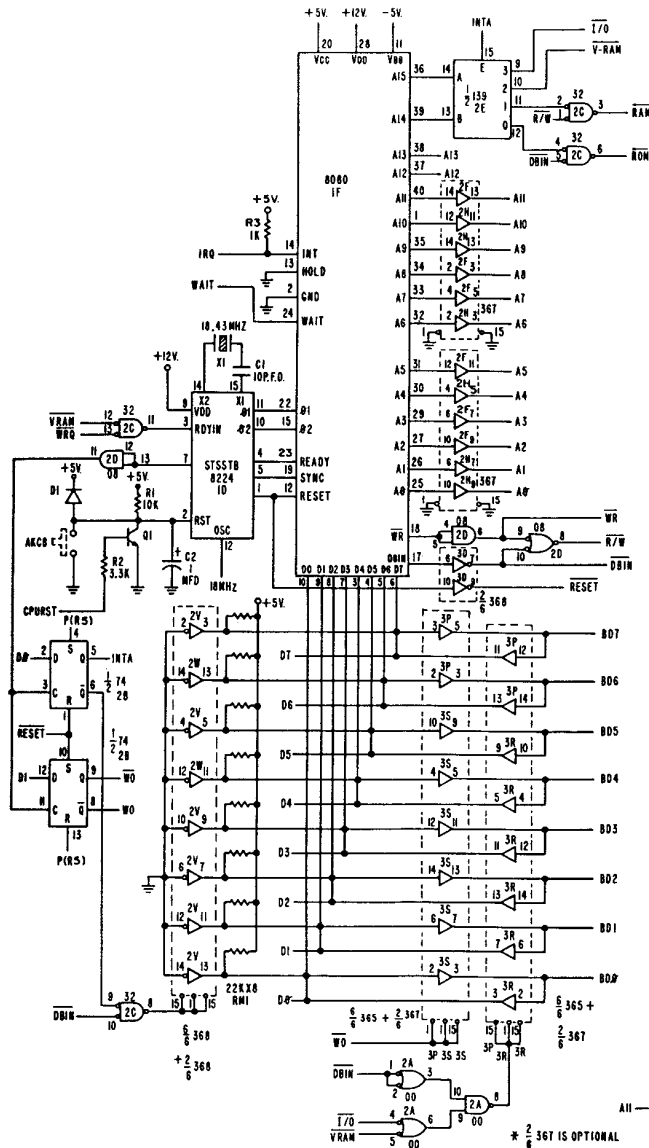

NOTE: 1. WHEN EPROM 2716 IS USED, REMOVE B AND JUMP TO A.
2. WHEN EPROM 2732 IS USED, REMOVE A AND JUMP TO B.

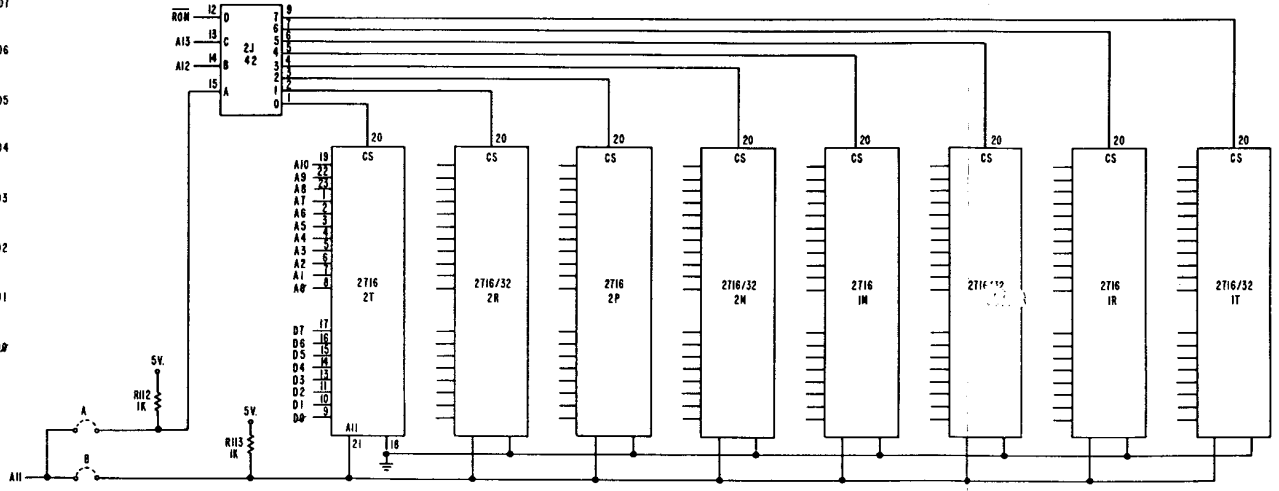

* 2/367 IS OPTIONAL

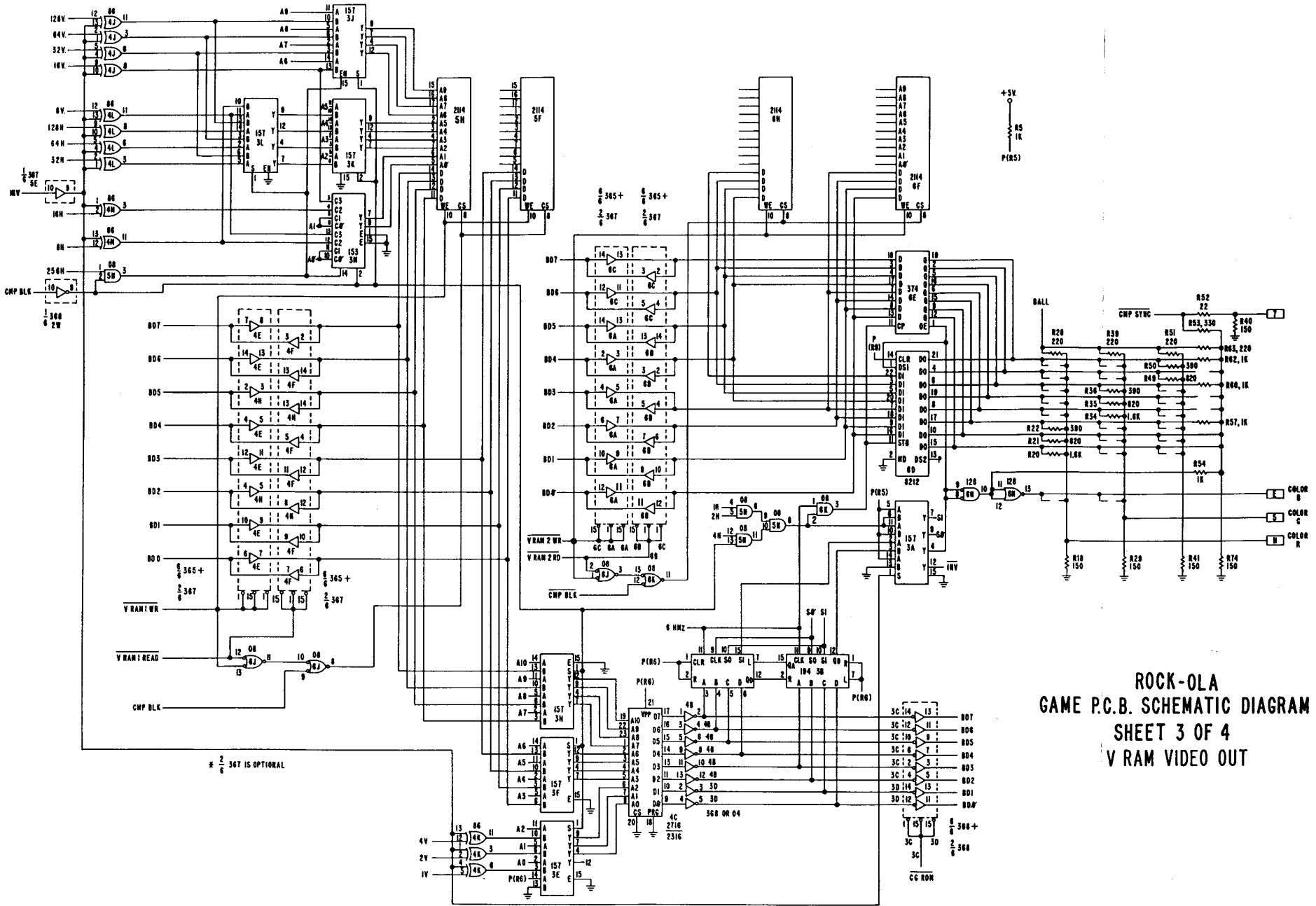

ROCK-OLA
GAME P.C.B. SCHEMATIC DIAGRAM
SHEET 3 OF 4
V RAM VIDEO OUT

ROCK-OLA
 GAME P.C.B. SCHEMATIC
 DIAGRAM
 SHEET 4 OF 4
 POWER SUPPLY AUDIO I/O

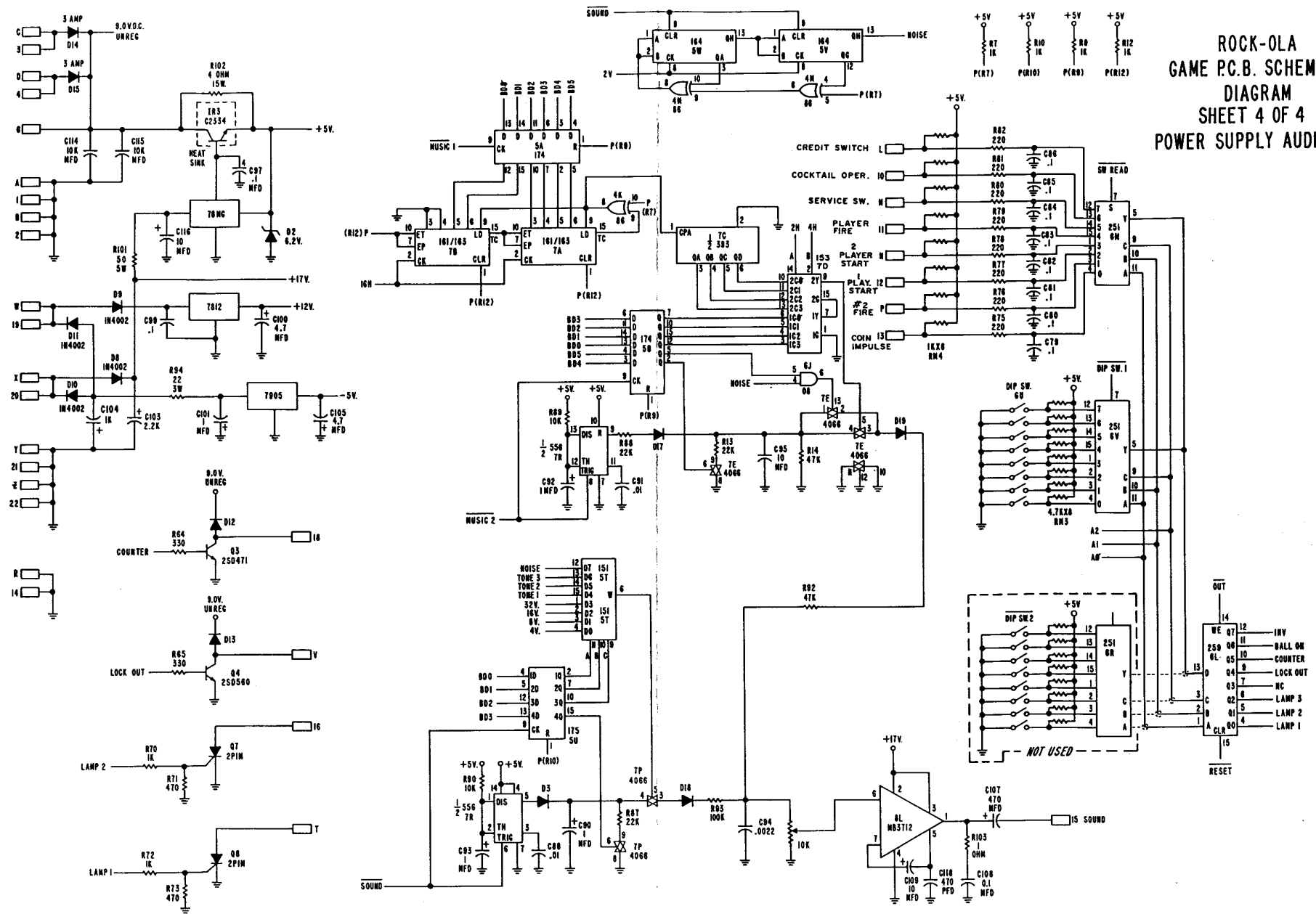

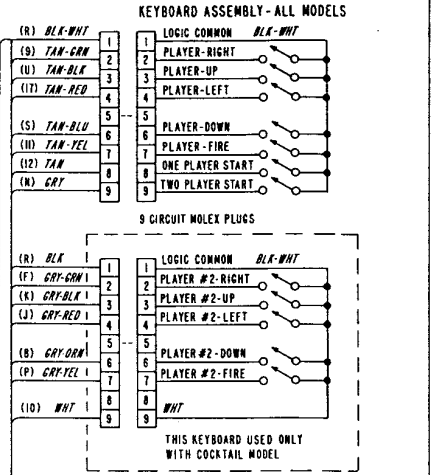
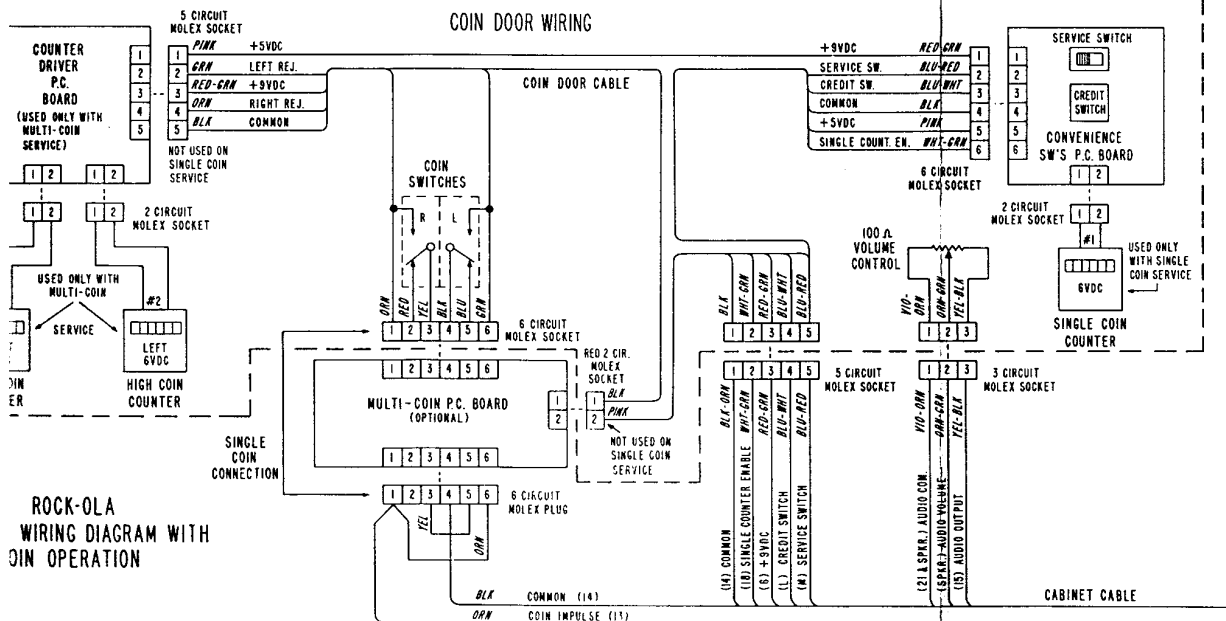
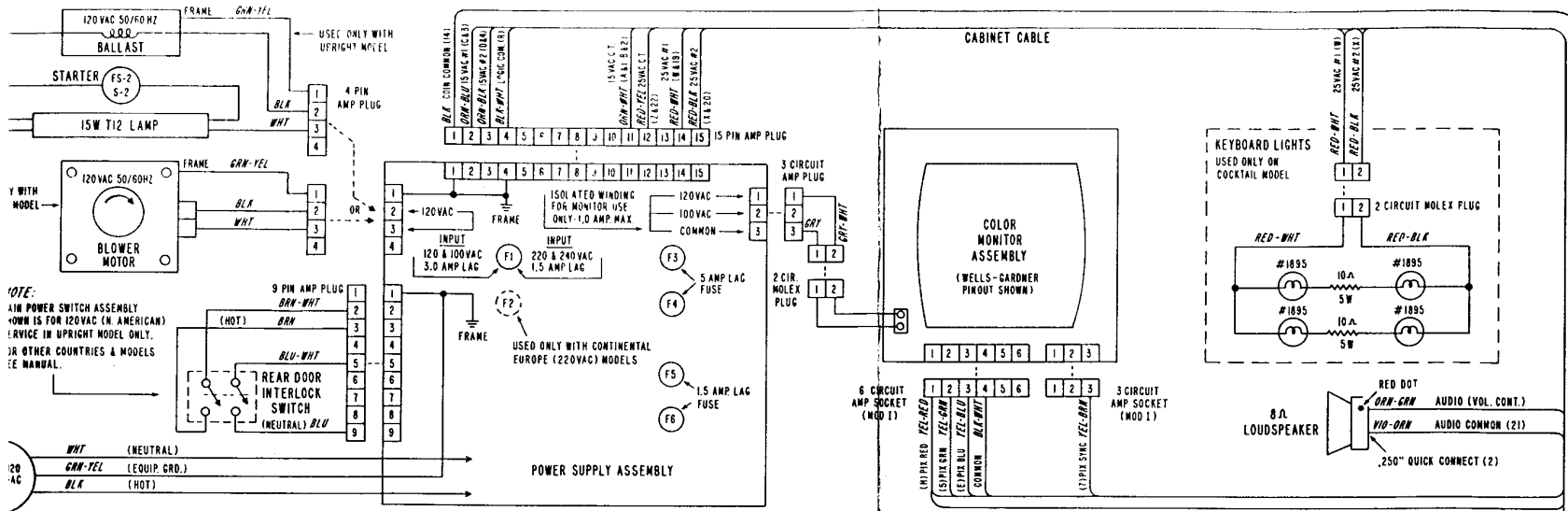

15VAC C.T.	ORN-WHT	A
15VAC C.T.	ORN-WHT	B
15VAC C.T.	ORN-WHT	C
15VAC #1	ORN-BLU	D
15VAC #2	ORN-BLK	E
PIX-BLUE	YEL-BLU	F
PIX-GRN	YEL-GRN	G
PLAYER #2-RIGHT	GRY-GRN	H
+9VDC	RED-GRN	I
PIX-RED	RED-RED	J
PIX-SYNC	YEL-ORN	K
PLAYER #2-LEFT	GRY-RED	L
PLAYER #2-DOWN	GRY-ORN	M
PLAYER #2-UP	GRY-BLK	N
PLAYER-RIGHT	TAN-GRN	O
CREDIT SWITCH	BLU-WHT	P
COCKTAIL OPER.	WHT	Q
SERVICE SWITCH	BLU-RED	R
PLAYER-FIRE	TAN-YEL	S
2 PLAYER-START	GRY	T
1 PLAYER-START	TAN	U
PLAYER #2-FIRE	GRY-YEL	V
COIN IMPULSE	ORN	W
LOGIC COMMON	BLK-WHT	X
COIN COMMON	BLK	Y
COUNTER COMMON	BLK-ORN	Z
PLAYER-DOWN	TAN-BLU	AA
AUDIO OUTPUT	YEL-BLK	AB
PLAYER-UP	TAN-BLK	AC
PLAYER-LEFT	TAN-RED	AD
SINGLE COUNT EN.	WHT-GRN	AE
25VAC #1	RED-WHT	AF
25VAC #2	RED-WHT	AG
25VAC #1	RED-BLK	AH
25VAC #2	RED-BLK	AI
AUDIO COMMON	VIO-ORN	AJ
25VAC C.T.	RED-YEL	AK
25VAC C.T.	RED-YEL	AL

ROCK-OLA WIRING DIAGRAM WITH COIN OPERATION

TO GAME PC BOARD ASSEMBLY
44 CIRCUIT AMP-LEAF 22 DUAL SOCKET

19" COLOR MONITOR SCHEMATIC DIAGRAM
MODEL K4677

