

HONDA

Power

Equipment

Owner's Manual

Rotary Mower

HRM215SXA • HRM215HXA

HRB215SXA • HRB215HXA



HONDA



Harmony

Keep this owner's manual handy, so you can refer to it any time, and make sure the manual stays with the lawn mower if you sell it.

This owner's manual is considered a permanent part of the lawn mower and should remain with the mower if resold.

The information and specifications included in this publication were in effect at the time of approval for printing. Honda Power Equipment Mfg., Inc. reserves the right, however, to discontinue or change specifications or design at any time without notice and without incurring any obligation whatever.

Honda lawn mowers meet Consumer Product Safety Commission (CPSC) blade safety requirements for walk-behind rotary mowers.

 WARNING: 
The engine exhaust from this product contains chemicals known to the State of California to cause cancer, birth defects or other reproductive harm.

Congratulations on your selection of a Honda lawn mower! We are certain you will be pleased with your purchase of one of the finest lawn mowers on the market.

We want to help you get the best results from your new mower and to operate it safely. This manual contains the information on how to do that; please read it carefully.

As you read this manual, you will find information preceded by a **NOTICE** symbol. That information is intended to help you avoid damage to your mower, other property, or the environment.

We suggest you read the Distributor's Limited Warranty and Emission Control System Warranty to fully understand coverage and your responsibilities of ownership.

When your mower needs scheduled maintenance, keep in mind that an authorized Honda servicing dealer is specially trained in servicing Honda mowers and is supported by the parts and service divisions of American Honda. Your Honda dealer is dedicated to your satisfaction and will be pleased to answer your questions and concerns.

Best Wishes,
Power Equipment Division
American Honda Motor Co., Inc.

INTRODUCTION

A FEW WORDS ABOUT SAFETY

Your safety, and the safety of others, are very important. And using this lawn mower safely is an important responsibility.

To help you make informed decisions about safety, we have provided operating procedures and other information on labels and in this manual. This information alerts you to potential hazards that could hurt you or others.

Of course, it is not practical or possible to warn you about all the hazards associated with operating or maintaining a lawn mower. You must use your own good judgment.

You will find important safety information in a variety of forms, including:

- **Safety Labels** — on the lawn mower.
- **Safety Messages** — preceded by a safety alert symbol  and one of three words: DANGER, WARNING, or CAUTION.

These signal words mean:

 **DANGER**

You **WILL** be **KILLED** or **SERIOUSLY HURT** if you don't follow instructions.

 **WARNING**

You **CAN** be **KILLED** or **SERIOUSLY HURT** if you don't follow instructions.

 **CAUTION**

You **CAN** be **HURT** if you don't follow instructions.

- **Safety Headings** — such as Important Safety Reminders or Important Safety Precautions.
- **Safety Chapter** — such as MOWER SAFETY.
- **Instructions** — how to use this mower correctly and safely.

This entire book is filled with important safety information — please read it carefully.

CONTENTS

Turn to the beginning of each chapter for a complete list of subjects.

MOWER SAFETY	5
Important information about some specific hazards, and what you can do to prevent injury.	
CONTROLS	9
Identification of components and information about how the controls work.	
BEFORE OPERATION	17
How to fuel and check your mower to be sure it is ready. How to prepare your lawn and yourself before you begin mowing.	
OPERATION	27
Starting and stopping the engine, safe mowing practices, and mowing tips.	
TRANSPORTING	41
How to load and carry your mower safely.	
MAINTENANCE	43
When and how to perform routine inspection, service, and adjustments to keep your mower in good operating condition.	
TROUBLESHOOTING	65
What to check if you have a problem with your mower.	
STORAGE	69
How to protect your mower from rust and corrosion, and ensure that it will start easily when you want to use it again.	
SPECIFICATIONS	77
Dimensions, capacities, and other technical information.	
ADDITIONAL INFORMATION	81
Additional information, Honda publications available to you, warranty, and how to contact us if you have a question or a warranty repair problem.	
INDEX	93
QUICK REFERENCE INFORMATION . . .	inside back cover

MOWER SAFETY

This chapter explains what you need to know to operate your mower safely.

IMPORTANT SAFETY INFORMATION	6
Avoid Rotating Blades	6
Clear Mowing Area	6
Keep Shields in Place	6
Refuel with Care	6
Wear Protective Clothing	6
Turn Engine Off When Not Mowing	6
IMPORTANT MESSAGE TO PARENTS	7
SAFETY LABEL LOCATIONS	8

MOWER SAFETY

IMPORTANT SAFETY INFORMATION

Most accidents with walk-behind mowers can be prevented if you follow all instructions in this manual and on the mower. The most common hazards, according to accident statistics, are discussed below, along with the best way to protect yourself and others.

Avoid Rotating Blades

Rotating blades can cause serious cuts and even amputate fingers, hands, toes, or feet. Keep away from the mower deck whenever the engine is running. If you need to adjust the cutting height, or work around the deck for any other reason, always shut off the engine. Wear heavy gloves and disconnect the spark plug cap when you need to clean the mower deck or handle the blade(s).

Clear Mowing Area

Mower blades can throw rocks and other objects with enough force to cause serious injury. Before mowing, carefully inspect the area and remove all sticks, stones, pieces of wire, and other loose objects. Never operate the blade(s) over gravel.

Keep Shields in Place

Guards and shields are designed to protect you from being hit by thrown objects and from hot engine parts and moving components. For your safety and the safety of others, keep all shields in place when the engine is running.

Refuel with Care

Gasoline is extremely flammable and gasoline vapor can explode. Refuel only outdoors, in a well-ventilated area, with the engine OFF. Never smoke near gasoline, and keep other flames and sparks away. Always store gasoline in an approved container.

Wear Protective Clothing

Wearing protective clothing will reduce your risk of injury. Long pants and eye protection reduce the risk of injuries from thrown objects. Sturdy shoes with aggressive soles will help protect your feet and give you better traction on slopes or uneven ground.

Turn Engine Off When Not Mowing

If you need to leave the mower for any reason, even just to inspect the lawn ahead, always turn the engine OFF.

IMPORTANT MESSAGE TO PARENTS

YOUR CHILDREN'S SAFETY IS VERY IMPORTANT to Honda. That's why we urge you to read this message before letting your youngster operate this lawn mower. Lawn mowers are tools, not toys. As with any equipment, bad judgments can result in serious injuries. You can help prevent accidents by making good decisions about if, when, and how your youngster operates this equipment.

The first question you'll need to ask is whether your youngster is capable of operating this mower safely. Remember, young people vary widely, and **AGE IS NOT THE ONLY FACTOR**.

Physically, a youngster must be **LARGE ENOUGH AND STRONG ENOUGH** to easily start the mower and control its direction. The youngster also needs enough size, strength, and coordination to comfortably reach and operate the controls.

Another, tougher question you need to ask is if your youngster has enough **MATURITY AND RESPONSIBILITY** to safely operate this mower. Does the young person think through problems and come to logical solutions? Be honest! Anyone who takes unnecessary risks and doesn't obey rules should not operate this lawn mower.

If you decide that your son or daughter can handle the mower safely, **CAREFULLY READ THE OWNER'S MANUAL** with your youngster. Make sure you both understand all instructions and safety information. Also, be sure your youngster wears sturdy shoes and other protective clothing when operating or handling the mower.

SUPERVISION is also very important. Walk with your youngster during the first few minutes of mowing. Even after the youngster has become confident with the mower, do not let the young person use the mower without good adult supervision. An adult should also be present during refueling and maintenance. In fact, it's up to parents to make sure that the mower is properly maintained and kept in safe operating condition.

By always placing safety first, your youngster will acquire useful skills and a sense of accomplishment. And you'll both get the best results from your lawn mower.

MOWER SAFETY

SAFETY LABEL LOCATIONS

The labels shown here contain important safety information. Please read them carefully. These labels are considered permanent parts of your mower. So if a label comes off or becomes hard to read, contact your dealer for a replacement.

(HRB215)

⚠ CAUTION

UNDER NORMAL USAGE, THIS BAG MATERIAL IS SUBJECT TO DETERIORATION AND WEAR, AND SHOULD BE CHECKED FREQUENTLY FOR BAG REPLACEMENT. THIS BAG CONFORMS TO A.N.S.I. STANDARD B71.1, ANY REPLACEMENT MUST MEET THIS STANDARD.

⚠ WARNING

Objects thrown by blade can cause serious injury.

- Inspect area and remove debris before mowing.
- Keep children and others away.
- Wear eye protection.
- Follow all instructions in your Owner's Manual.

DO NOT OPERATE UNLESS GUARD IS CLOSED OR BAG IS IN PLACE

⚠ DANGER

KEEP HANDS and FEET AWAY



⚠ CAUTION

HOT MUFFLER CAN BURN YOU.
Stay away if engine has been running.

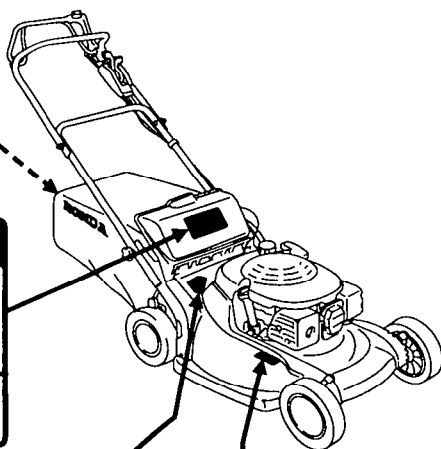

CONTROLS

This chapter shows the locations of controls and other important parts of your mower, and it tells you how the controls work.

COMPONENT IDENTIFICATION	10
DESCRIPTION OF CONTROLS	12
Fuel Valve	12
Throttle Lever	12
Blade Control Lever	13
Drive Clutch Lever	13
Shift Lever	14
HRM215SXA & HRB215SXA	14
HRM215HXA & HRB215HXA	14
Cutting Height Adjustment Levers	15

CONTROLS

COMPONENT IDENTIFICATION

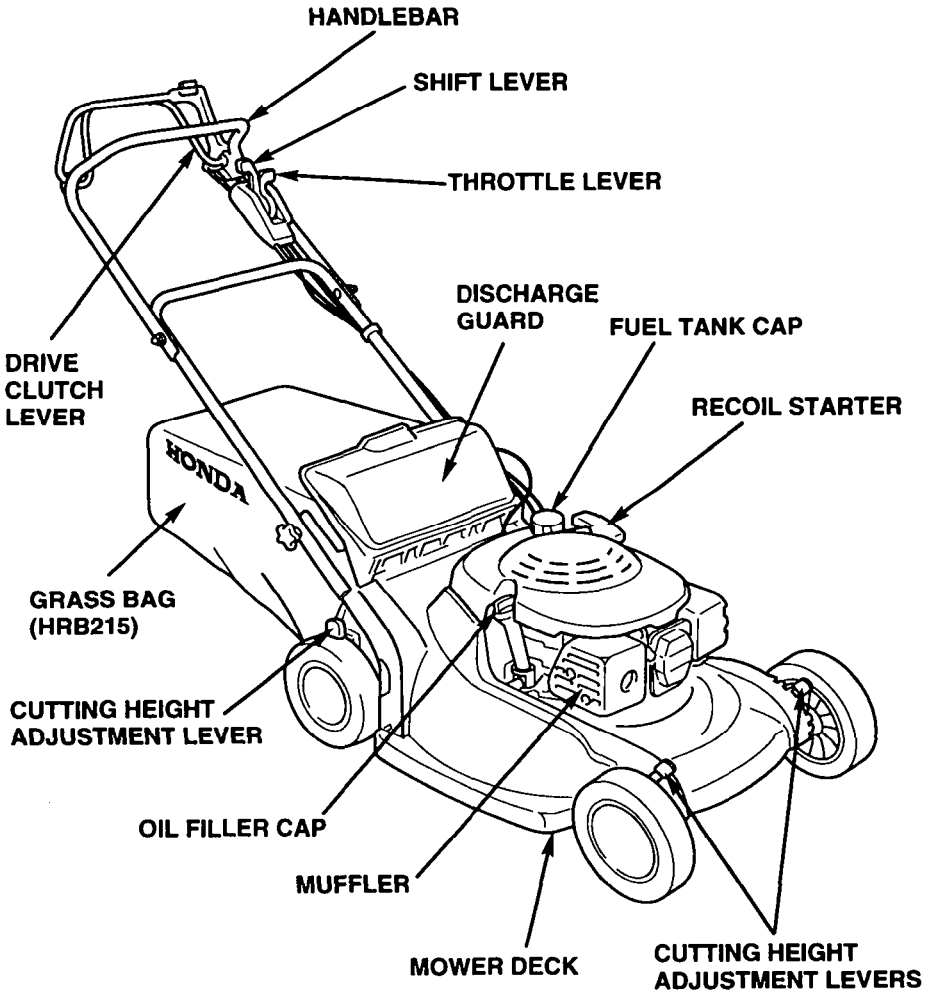

HRB215K3SXA: Self-propelled, high-lift blade, and grass bag.

HRB215K3HXA: Self-propelled, hydrostatic transmission, high-lift blade, and grass bag.

HRM215K3SXA: Self-propelled, mulching blades, and mulching plug.

HRM215K3HXA: Self-propelled, hydrostatic transmission, mulching blades, and mulching plug.

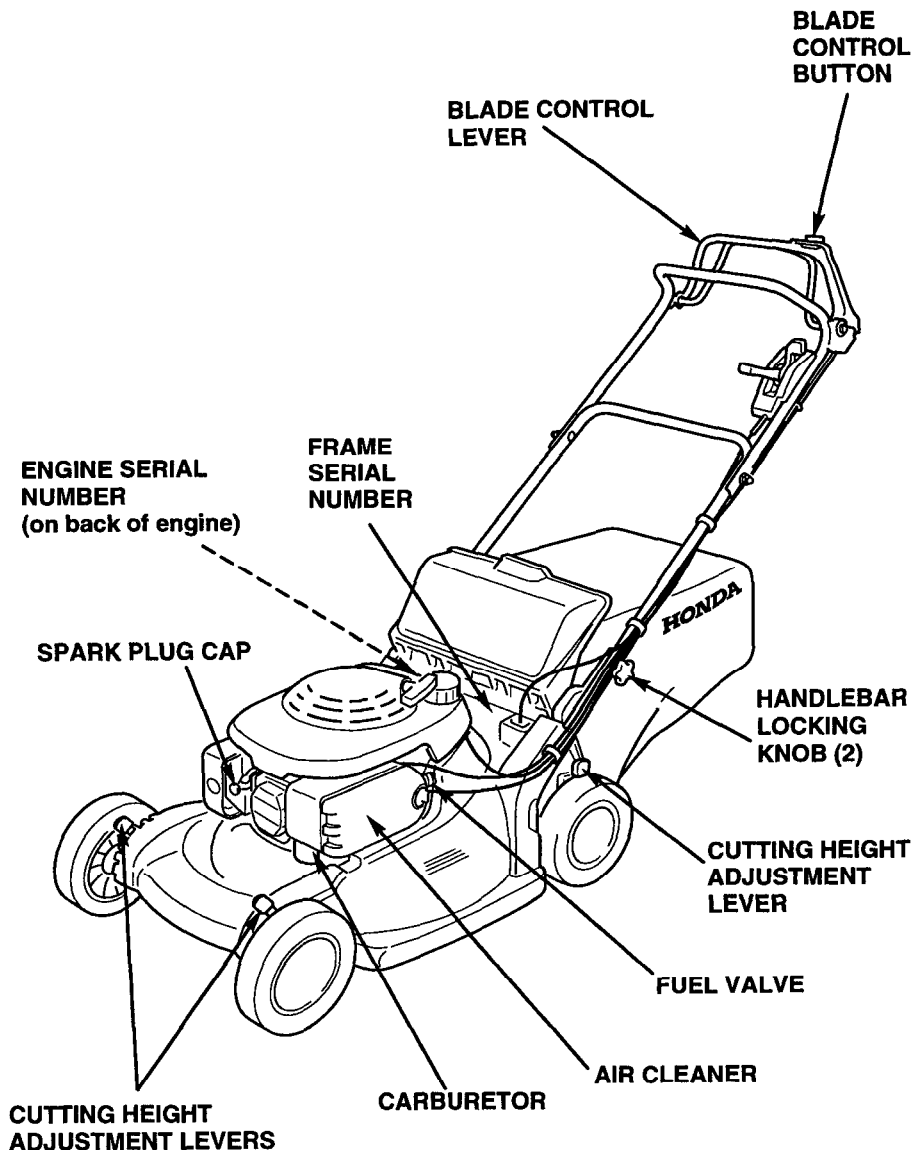

Record the frame and engine serial numbers in the space below. You will need these serial numbers when ordering parts and when making technical or warranty inquiries (see page 90).

Frame serial number: MZB -

Engine serial number: GJAB -

CONTROLS



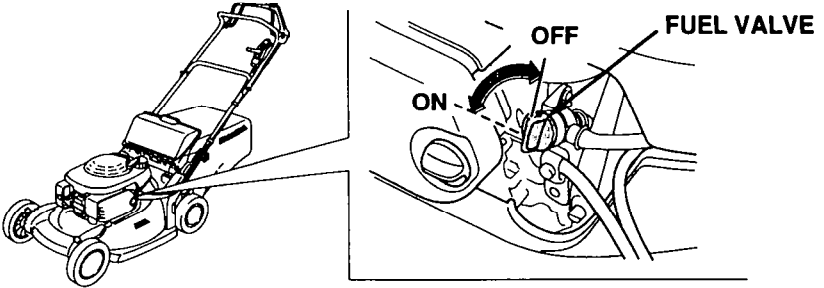

DESCRIPTION OF CONTROLS

Fuel Valve

The fuel valve opens and closes the fuel passage from the fuel tank to the carburetor.



Throttle Lever

-  **CHOKE** --- For starting a cold engine.
-  **FAST** ---- For restarting a warm engine and for mowing.
-  **SLOW** ---- For idling the engine.
-  **STOP** ---- For stopping the engine.

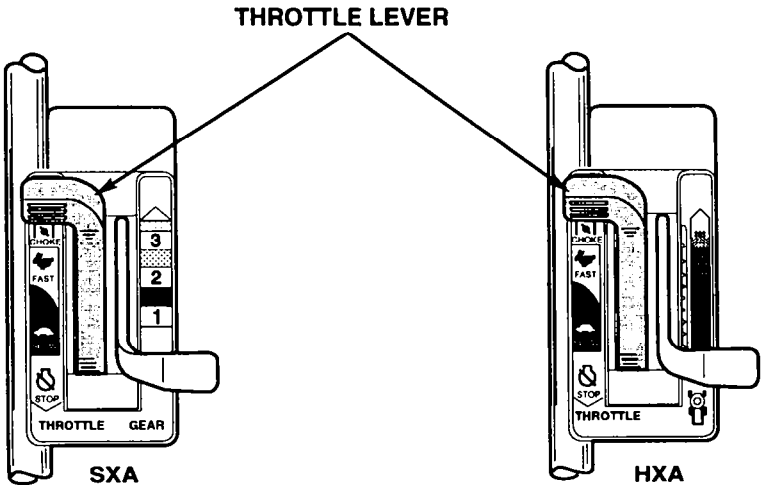

Blade Control Lever

The blade control lever starts and stops blade rotation. To start blade rotation, the button must be pressed before pushing the blade control lever forward.

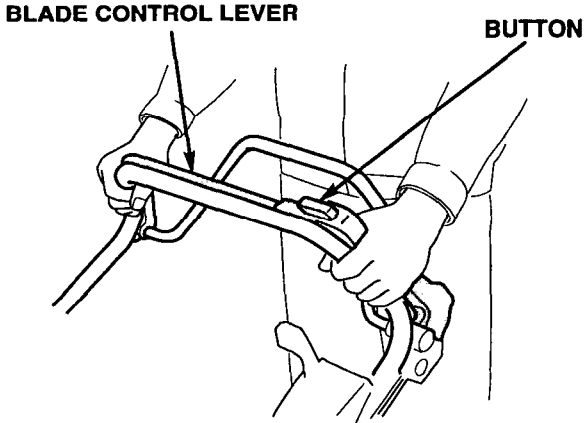

Drive Clutch Lever

The drive clutch lever engages and disengages the transmission that drives the rear wheels.

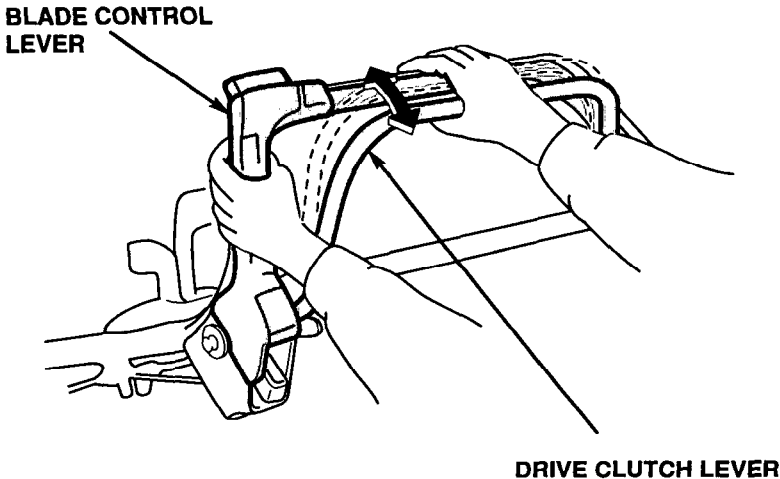

CONTROLS

Shift Lever

The shift lever selects and controls the mower's drive speed.

HRM215SXA & HRB215SXA

- 1 (slow) — For mowing thick grass or maneuvering in small areas.
- 2 (medium) — For intermediate self-propelled mowing speed.
- 3 (fast) — For maximum self-propelled transport speed.

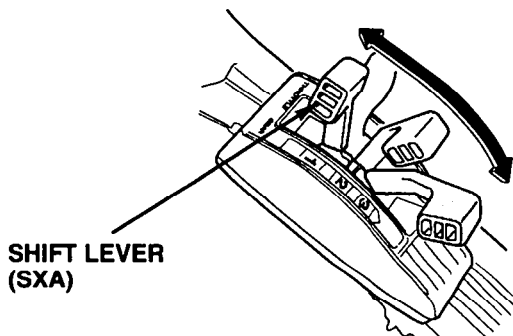

HRM215HXA & HRB215HXA

STOP or SLOW — With the shift lever all the way back and the drive clutch lever engaged, the mower will move slowly or not at all. Use a slow speed for mowing thick grass or maneuvering in small areas.

FAST — For maximum self-propelled speed in large, open areas, and for transport.

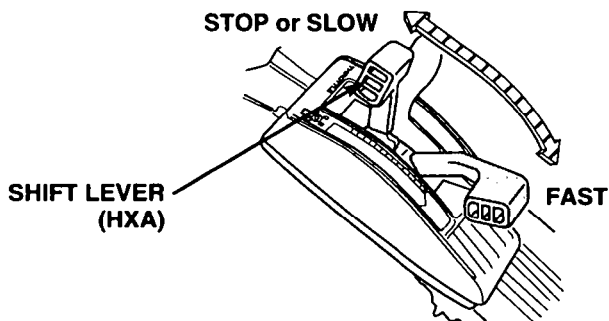

Cutting Height Adjustment Levers

There are six settings to choose from, as shown in the illustration. The cutting height figures are approximate. The actual height of cut grass will vary with lawn and soil conditions.

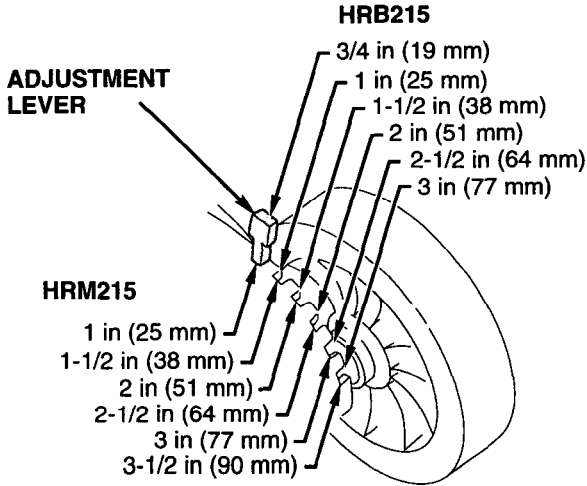

There is an adjustment lever on each wheel.

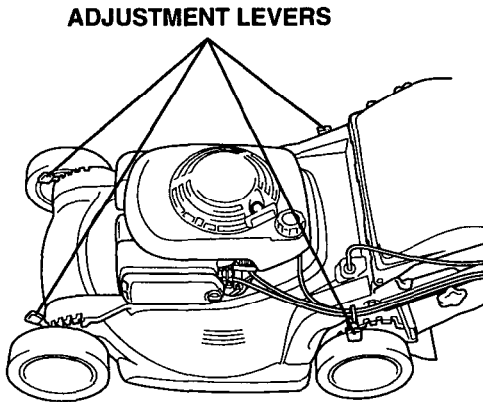

BEFORE OPERATION

This chapter explains how to fuel and check your mower to be sure it is ready, and it tells you how to prepare your lawn and yourself before you begin mowing.

ARE YOU READY TO MOW?	18
CHECK YOUR LAWN	18
Objects	18
People and Pets	18
Lawn	18
CHECK YOUR MOWER	19
Blade(s)	19
Engine Oil Level	20
Fuel	21
Air Cleaner Inspection	22
Handlebar Height Adjustment	23
Grass Bag (HRB215)	24
Inspection	24
Installation	24
Removal	24
Mulching Plug (HRM215)	25
Cutting Height	25

BEFORE OPERATION

ARE YOU READY TO MOW?

Be sure to wear protective clothing. Long pants and eye protection can lower your risk of injury from thrown objects. Wear footwear that protects your feet and won't let you slip if you mow on slopes or uneven ground.

CHECK YOUR LAWN

For your safety and for the safety of others, always inspect the area before mowing.

Objects

Anything which can be picked up by the blade(s) and thrown is a potential hazard to you and others. Look for things like stones, sticks, bones, and wire. Remove them from the mowing area.

People and Pets

People and animals near the mowing area can move into your path or into a position where they could be struck by thrown objects. Clear the area of people and pets, especially children. Their safety is your responsibility.

Lawn

Check the length and condition of the grass, so you will know what cutting height and mowing speed to use.

Avoid mowing wet grass. Not only will wet grass clog your mower deck and collect in clumps on the lawn, it also gives poor traction, increasing your risk of losing your footing.

CHECK YOUR MOWER

Blade(s)

1. Move the throttle lever to the STOP position and move the fuel valve to the OFF position (see page 12).
2. Disconnect the spark plug cap from the spark plug (see page 52).
3. Tilt the mower to the right, so the carburetor side is up. This will help to prevent fuel leakage and hard starting.
4. Inspect blade(s) for wear and damage.

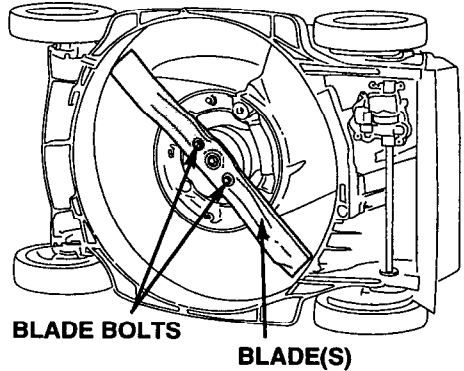

⚠ WARNING

A worn, cracked, or damaged blade can break, and pieces of the damaged blade can become dangerous projectiles.

Thrown objects can cause serious injury.

Inspect the blade regularly, and do not operate the mower with a worn or damaged blade.

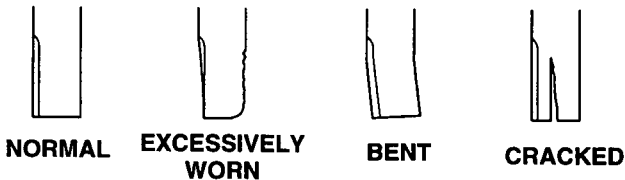

A dull blade can be sharpened, but a blade that is worn out, bent, cracked, or otherwise damaged must be replaced. A worn or damaged blade can break, causing blade pieces to be thrown from the mower.

When a blade needs sharpening or replacement take the lawn mower to an authorized Honda servicing dealer. Or, if you have a torque wrench, you can remove and install a blade(s) yourself (see pages 62 - 63).

Check that the blade bolts are tight (see page 63).

BEFORE OPERATION

Engine Oil Level

Check the engine oil level with the engine stopped and the mower on a level surface.

1. Remove the oil filler cap, and wipe the dipstick clean.

2. Insert and remove the dipstick without screwing it into the filler neck. Check the oil level shown on the dipstick.

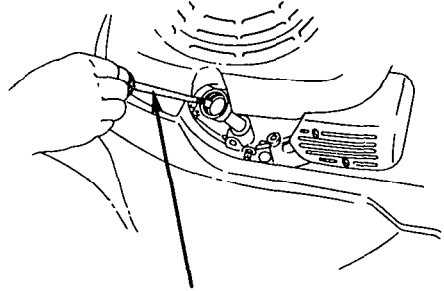

FILLER CAP/DIPSTICK

3. If the oil level is low, add oil to reach the upper limit mark on the dipstick (see page 50).

4. After checking the engine oil level, screw in the filler cap/dipstick securely.

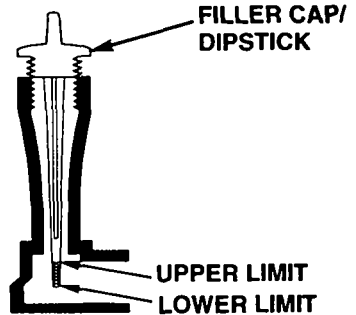

Fuel

Fuel tank capacity: 0.26 US gal (1.0 ℓ)

Refuel in a well-ventilated area before starting the engine. If the engine has been running, allow it to cool. Refer to page 55 for fuel recommendations and page 91 for information about oxygenated fuels.

Remove the fuel tank cap and check the fuel level. Refill the tank if the fuel level is low. Refuel carefully to avoid spilling fuel. Do not overfill; there should be no fuel in the filler neck. After refueling, tighten the fuel tank cap securely.

⚠ WARNING

Gasoline is highly flammable and explosive.

You can be burned or seriously injured when handling fuel.

- Stop the engine and keep heat, sparks, and flame away.
- Handle fuel only outdoors.
- Wipe up spills immediately.

Never refuel the mower inside a building where gasoline fumes may reach flames or sparks. Keep gasoline away from appliance pilot lights, barbecues, electric appliances, power tools, etc.

Spilled fuel is not only a fire hazard, it causes environmental damage. Wipe up spills immediately.

NOTICE

Fuel can damage paint and plastic. Be careful not to spill fuel when filling your fuel tank. Damage caused by spilled fuel is not covered under warranty.

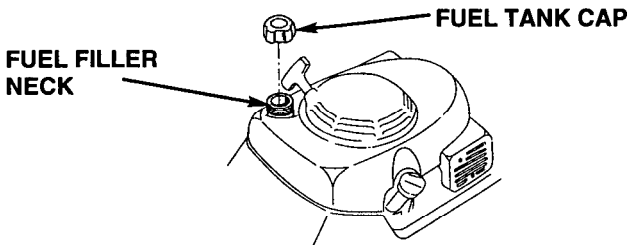

BEFORE OPERATION

Air Cleaner Inspection

Check that the air filters are clean and in good condition. Dirty air filters will restrict air flow to the carburetor, reducing engine performance. Refer to page 51 for air cleaner service.

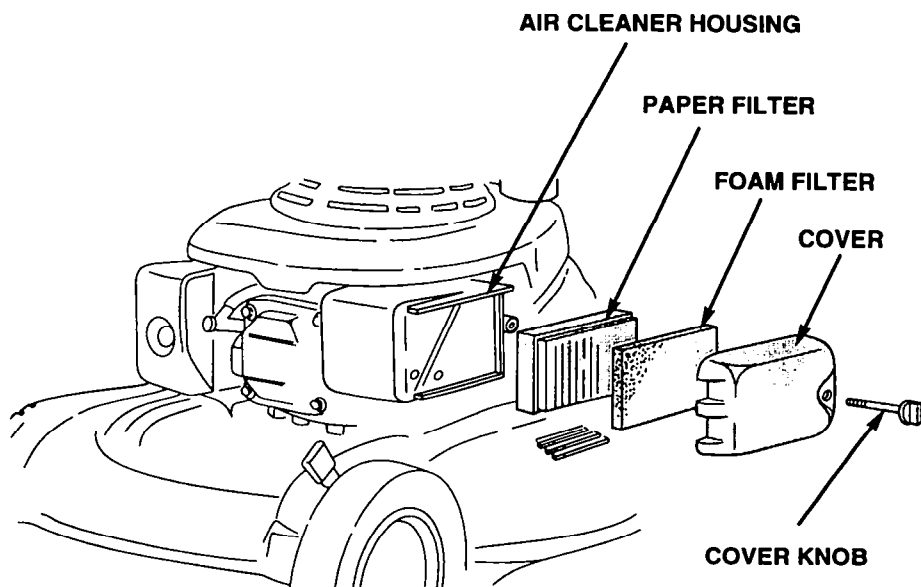

Handlebar Height Adjustment

Adjust handlebar height for a comfortable operating position.

1. Loosen the handlebar locking knobs.
2. Spread the lower ends of the handlebar to release the locating pins.
3. Move the handlebar up or down, so the locating pins engage other holes on the handlebar mounting brackets.
4. Tighten the handlebar locking knobs securely.

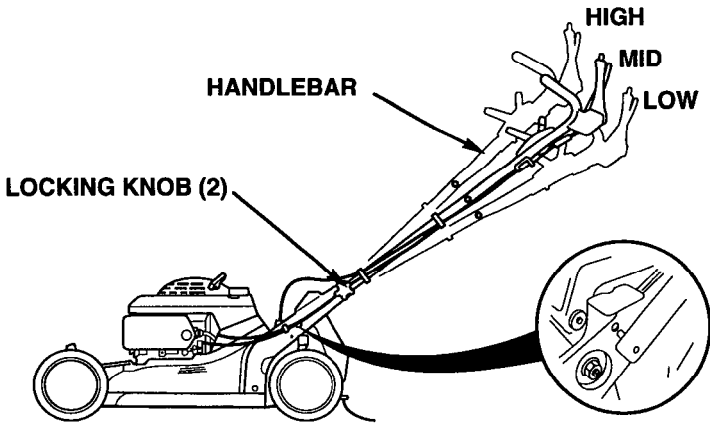

BEFORE OPERATION

Grass Bag (HRB215)

A lawn mower works like a vacuum cleaner; it blows air through the bag, which traps the grass clippings. Always empty the grass bag before it becomes filled to the limit of its capacity. Bagging performance will diminish after the bag becomes about 90% filled. Also, the bag is easier to empty when it is not packed full.

Inspection

Inspect the grass bag for tears, holes, and excessive wear. The grass bag wears during normal use and will eventually require replacement. Grass bag replacement is explained on page 64.

Installation

1. Raise the discharge guard, and hook the grass bag onto the mower deck as shown.
2. Release the discharge guard to secure the grass bag.

Removal

1. Raise the discharge guard, grasp the grass bag handle and remove the grass bag.
2. Release the discharge guard.
3. When the grass bag is clear of the discharge guard, you can lift it through the handlebar opening, or you can remove it to the rear of the mower below the handlebar.

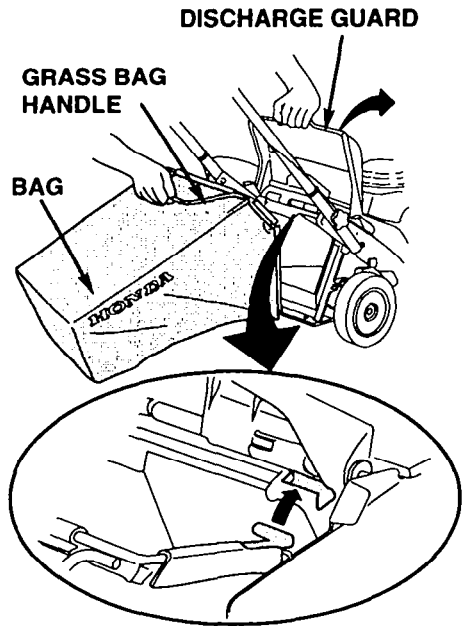

Mulching Plug (HRM215)

The mulching plug contours the mower deck for efficient mulching.

You can quickly remove the plug to install a grass bag or side-discharge chute, which are available as optional equipment.

Raise the discharge guard to remove or install the mulching plug. When installing, be sure the plug is fully inserted, and the discharge guard is closed.

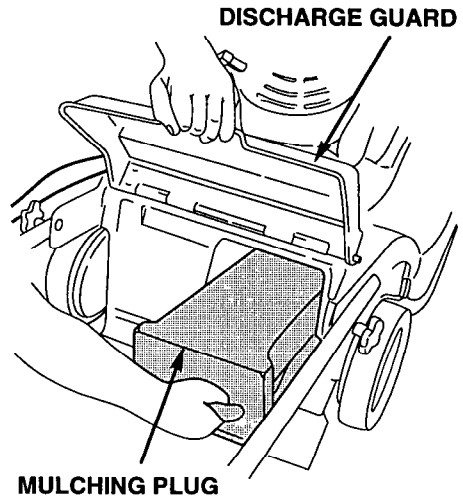

Cutting Height

Check the mower deck cutting height settings, and be sure that all four adjustment levers are set to the same cutting height position.

ADJUSTMENT LEVERS

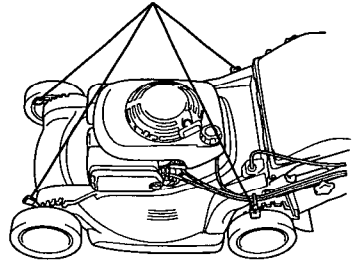

To adjust cutting height, pull each adjustment lever toward the wheel, and move it into another notch.

If you are not sure what cutting height to select, start with a high setting and check the appearance of the lawn after mowing a small area. Then readjust cutting height if necessary.

ADJUSTMENT LEVER

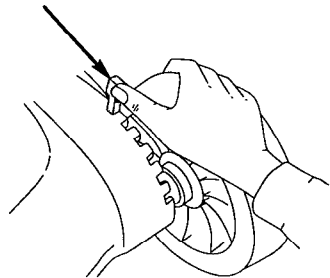

OPERATION

This chapter tells you how to operate the mower safely and effectively.

MOWING PRECAUTIONS	28
STARTING THE ENGINE	29
OPERATING THE CONTROLS FOR MOWING	31
Throttle Lever	31
Blade Control Lever	31
Drive Clutch Lever	32
HRM215SXA & HRB215SXA	32
HRM215HXA & HRB215HXA	32
All Models	32
Shift Lever	33
HRM215SXA & HRB215SXA	33
HRM215HXA & HRB215HXA	33
STOPPING THE ENGINE	34
SAFE MOWING PRACTICES	35
Slopes	35
Obstacles	36
Gravel and Loose Objects	36
MOWING TIPS	37
When to Mow	37
Cutting Height	37
Cutting Width	37
Blade Speed	38
Blade Sharpness	38
Dry Grass	38
Wet Grass	38
Fallen Leaves	38
Clogged Mower Deck	38
Mowing Patterns	39
Mulching	39
Bagging	39
Side-Discharge Mowing	39

OPERATION

MOWING PRECAUTIONS

Before operating the mower for the first time, please review the *IMPORTANT SAFETY INFORMATION* beginning on page 6 and the previous chapter, titled *BEFORE OPERATION*.

Even if you have operated other mowers, take time to become familiar with how this mower works and practice in a safe area until you build up your skills.

For your safety, avoid starting or operating the engine in an enclosed area such as a garage. Your mower's exhaust contains poisonous carbon monoxide gas which can collect rapidly in an enclosed area and cause illness or death.

STARTING THE ENGINE

Before starting, always release the blade control lever and drive clutch lever, so the blade will not turn, and the mower will not move forward, when you operate the starter.

1. Turn the fuel valve to the ON position.

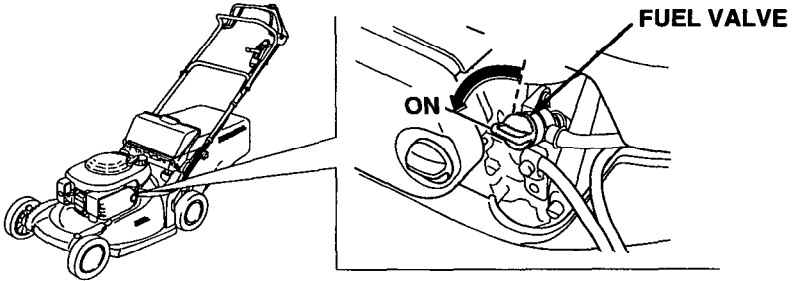

2. Move the throttle lever to the proper starting position.

COLD ENGINE:

Move the throttle lever to the **CHOKE** position.

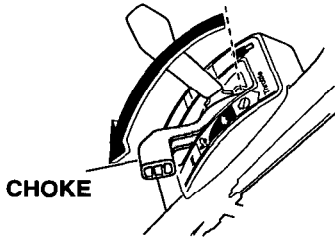

WARM ENGINE:

Move the throttle lever to the **FAST** position.

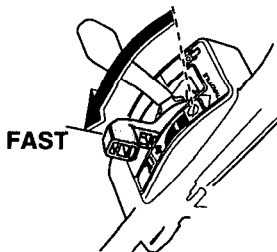

OPERATION

3. Place your foot on the mower deck step. Pull the starter grip lightly until you feel resistance, then pull briskly. Return the starter grip gently.

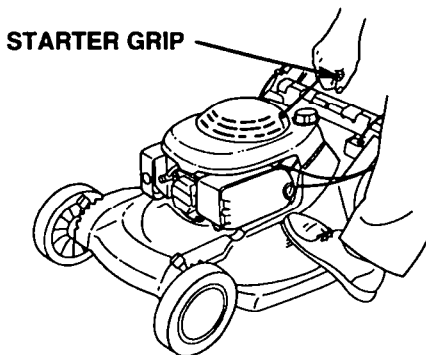

4. If the CHOKE position was used during starting, move the throttle lever away from the CHOKE position as soon as the engine warms up enough to run smoothly without use of the choke. Set the throttle lever at FAST to mow or at SLOW to idle.

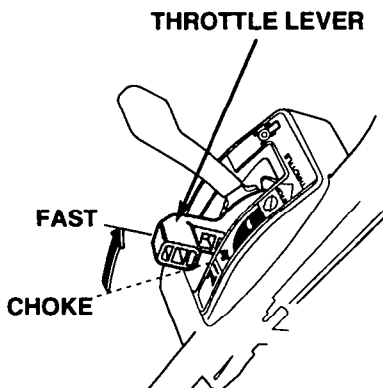

OPERATING THE CONTROLS FOR MOWING

Throttle Lever

For best cut quality, always mow with the throttle lever in the FAST position. When the blade(s) rotates at the preset fast speed, it creates a strong fan action that lifts and cuts grass more efficiently. Do not try to increase the preset engine speed: the blade could fracture and come apart.

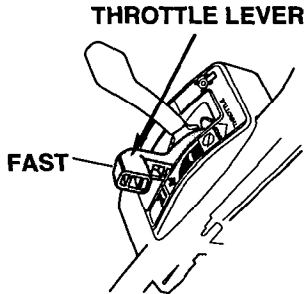

When you need to empty the grass bag or leave the mower for any reason, move the throttle lever to the STOP position.

Blade Control Lever

To start blade rotation, press the button on top of the blade control lever, then push the lever forward quickly and hold it against the handlebar.

Release the blade control lever to stop the blade(s).

Operate the blade control lever with a quick and complete motion, so the blade control is always either fully engaged or stopped. This will help to prevent stalling the engine, and it will also extend the service life of the blade control mechanism.

Always release the blade control lever before starting the engine to prevent the blade(s) from turning.

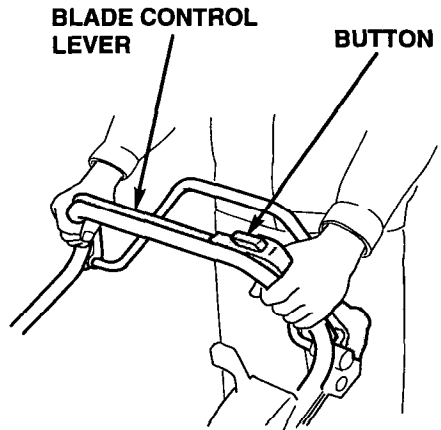

OPERATION

Drive Clutch Lever

HRM215SXA & HRB215SXA

Push the drive clutch lever forward to propel the mower.

Release the drive clutch lever to stop the mower's forward movement.

HRM215HXA & HRB215HXA

You can control self-propelled speed with the drive clutch lever. The mower will move gradually faster as you push the drive clutch lever forward. If you push the lever all the way forward to the handlebar, the mower will move at the speed determined by the shift lever setting (see page 33).

When moving and using the drive clutch lever to change self-propelled speed, continue to fully hold the blade control lever against the handlebar. This will help to extend the service life of the blade control mechanism.

ALL MODELS

For self-propelled mowing, press the button on top of the blade control lever, push the blade control lever forward, then push the drive clutch lever forward. The drive clutch lever can be used to hold the blade control lever against the handlebar.

Always release the drive clutch lever before starting the engine. If the drive clutch is engaged, the mower will move forward when you operate the starter.

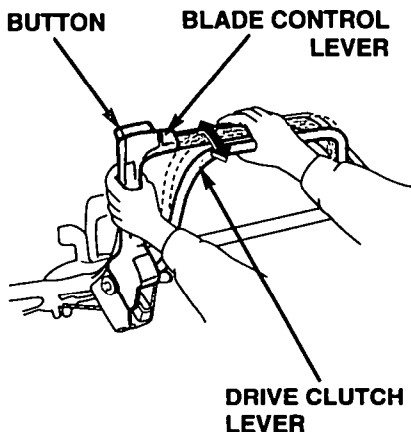

Shift Lever

Use the shift lever to select the forward speed at which you wish to mow.

Do not use the throttle lever to adjust your forward speed. The throttle lever must remain in the FAST position for good mowing performance. Otherwise, cut quality suffers.

HRM215SXA & HRB215SXA

You can shift gears without releasing the drive clutch lever, but the transmission may not shift smoothly if the mower is pulling hard. For smoother operation, release the drive clutch lever before shifting gears.

For maximum mowing performance, use 1st and 2nd gears for mowing and 3rd gear for transporting.

To avoid incomplete gear engagement, be sure the shift lever is centered in one of the three detent positions.

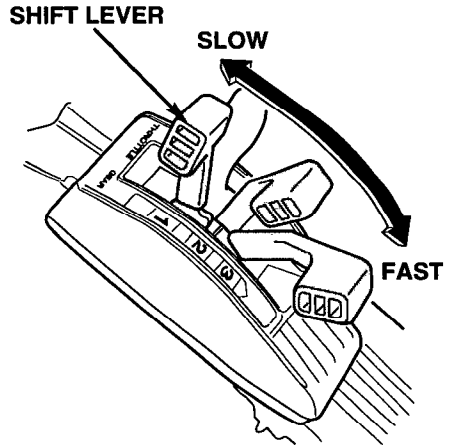

HRM215HXA & HRB215HXA

For maximum mowing performance, use the lower speed range for mowing and the higher speed range for transporting.

With the shift lever all the way back and the drive clutch lever engaged, the mower will move slowly or not at all.

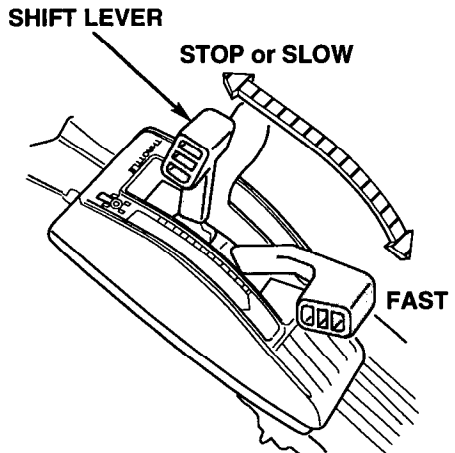

OPERATION

STOPPING THE ENGINE

1. Release the drive clutch lever and blade control lever.

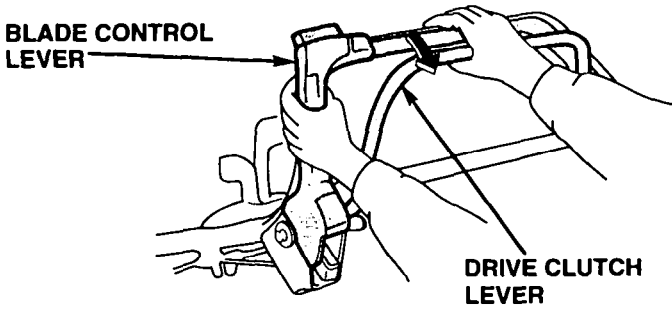

2. Move the throttle lever to the STOP position.

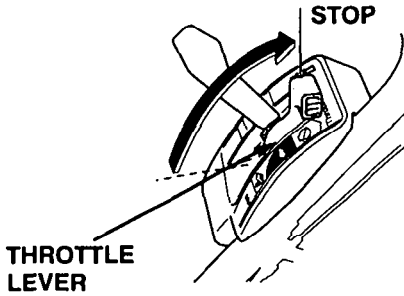

3. When the mower is not in use, turn the fuel valve to the OFF position.

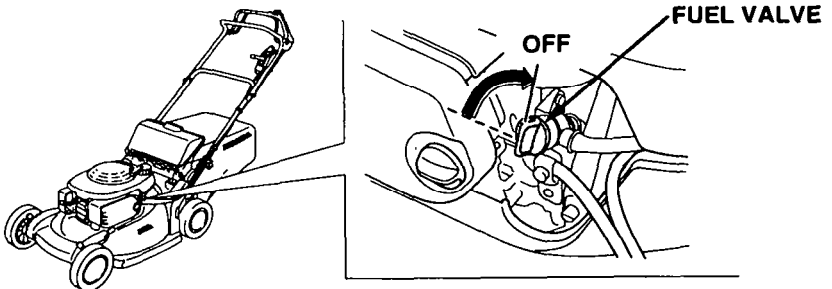

SAFE MOWING PRACTICES

For your safety, keep all four wheels on the ground, and be careful to avoid losing your footing and your control of the mower. Keep a firm grip on the handlebar, and walk, never run, with the mower. Be very careful when mowing uneven or rough ground.

If stuck, do not kick or shove the mower with your foot. Use the handlebar to control the mower.

⚠ WARNING

The blade is sharp and spins at high speed.

A spinning blade can cut you severely and can amputate fingers and toes.

- Wear protective footwear.
- Keep your hands and feet away from the mower deck while the engine is running.
- Stop the engine before performing any adjustment, inspection, or maintenance.

Slopes

Mow across slopes, not up and down. Avoid steep slopes (more than 20°), and be careful when changing direction. Mowing on a slope when the grass is damp or wet could cause you to slip, fall, and lose control of the mower.

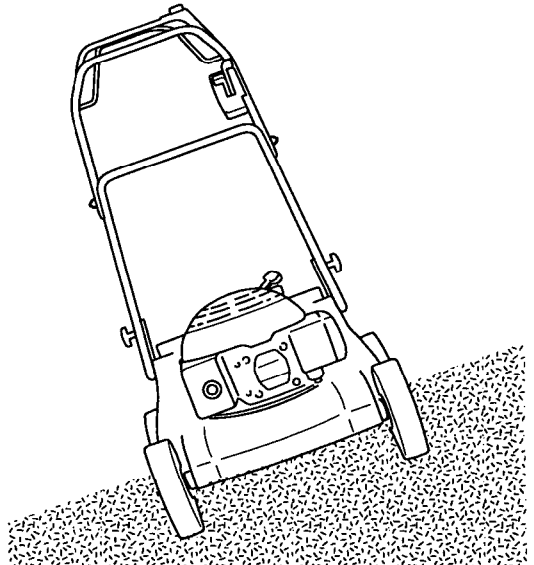

OPERATION

Obstacles

Use the side of the mower to cut close to large obstacles, such as fences or walls.

Release the drive clutch lever to disengage the drive when mowing around trees and other obstacles. Push the mower around obstacles for better directional control. Be careful when mowing over obstacles embedded in the lawn, such as sprinkler heads, paving, edging, etc. Avoid anything that sticks up above the surface of the lawn.

If the blade hits something, or if the mower starts to vibrate, stop the engine immediately, disconnect the spark plug cap, and check for damage (see page 19). Striking objects may damage the blade(s), bend the crankshaft, and/or break the mower deck or other components. Vibration usually indicates serious trouble.

The Distributor's Limited Warranty does not cover parts damaged by accident or collision.

Gravel and Loose Objects

Gravel, loose stones, and landscaping material can be picked up by the mower and thrown many feet with enough force to cause serious personal injury and/or property damage. The best way to prevent potential injury from thrown objects is to release the blade control lever to stop the blade(s) before reaching areas with gravel, loose stones, or landscaping material.

MOWING TIPS

When to Mow

Most grasses should be mowed when they have grown $\frac{1}{2}$ to 1 inch above their recommended height.

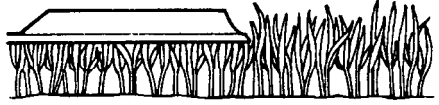

More frequent mowing is required for mulching than for bagging. For best results, you may need to mow the lawn twice a week during the growing season.

Cutting Height

Consult a local nursery or lawn and garden center for cutting height recommendations and advice about specific types of grasses and growing conditions in your area.



LONG ENOUGH

If you look closely, you'll see that most grass has stems and leaves. If you cut off the leaves, you'll scalp the lawn. Let the grass recover between mowings. Your mower will work better, and your lawn will look better.



TOO SHORT

If your grass gets too tall, cut it once at the highest cutting height setting, then mow again in 2 or 3 days. Don't take off more than one third of total grass height in any one mowing, or brown patches may develop.

Cutting height adjustment is explained on page 15.

Cutting Width

For an even lawn finish, overlap each mowing swath by a few inches. If the grass is very tall or thick, use more overlap and a narrower mowing swath.

OPERATION

Blade Speed

The blade must spin very fast to cut properly. Always use the FAST throttle setting, and keep the engine running at maximum rpm.

If engine speed drops, it could mean the engine is being overloaded by the blade trying to cut too much grass. Mow a narrower swath, move the mower slower, or raise the cutting height.

Blade Sharpness

A sharp blade cuts cleanly. A dull blade tears the grass, leaving shredded ends that turn brown. When your blade doesn't cut cleanly anymore, have it sharpened or replaced.

Dry Grass

If the ground is too dry, mowing will stir up a lot of dust. Besides being unpleasant to work in, too much dust will clog the carburetor air filter.

If dust is a problem, water your lawn the day before mowing. Mow when the grass is dry to your touch, but the soil is still moist.

Wet Grass

Wet grass is slippery and can make you lose your footing. Also, wet grass clippings will clog the mower deck and collect in clumps on the lawn. Always wait for wet grass to dry before mowing.

Fallen Leaves

When equipped with a grass bag, your mower can be used to pick up fallen leaves for disposal. If using the mower to bag large amounts of fallen leaves, and not for mowing, set the cutting height adjustment levers so the front of the mower deck is one or two settings higher than the rear. An optional leaf shredder is available.

If you want to mulch fallen leaves into your lawn, don't let the leaf cover get too deep before you begin. For best results, start mulching while grass still shows through the leaf cover. In places where fallen leaves completely cover the grass, remove the leaves by raking, or install a grass bag, so your mower can pick them up for disposal.

Clogged Mower Deck

Before clearing a clogged mower deck, stop the engine and turn the fuel valve to the OFF position. With the spark plug cap disconnected, tilt the mower so the carburetor side is up.

Clear a clogged deck with a stick, not your hands.

Mowing Patterns

Your Honda mower will work most efficiently if you use the following mowing patterns as much as possible. Mower deck and equipment design, and the direction in which the blade rotates, cause these mowing patterns to give the best results.

Mulching

(HRB215 requires optional mulching kit)

Use a counterclockwise mowing pattern. If the lawn has an irregular shape, or many obstacles, divide it into sections where you can use counterclockwise mowing patterns

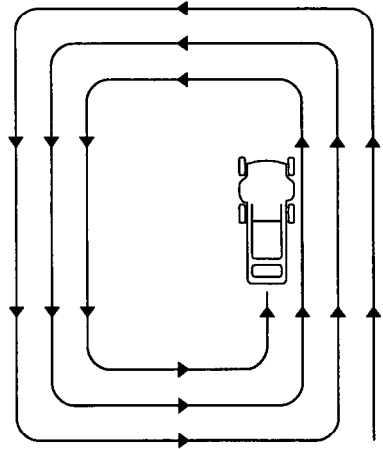

MULCHING PATTERN

Bagging

(HRM215 requires optional grass bag kit)

Use a clockwise mowing pattern. This will give the best bagging performance, leaving the least amount of clippings on the lawn.

Side-Discharge Mowing

(requires optional side-discharge chute)

Where possible, use the same mowing pattern recommended for bagging. If the lawn has an irregular shape, or many obstacles, divide it into sections where clippings will be discharged away from uncut areas. This will prevent clippings from piling up in the path of the mower.

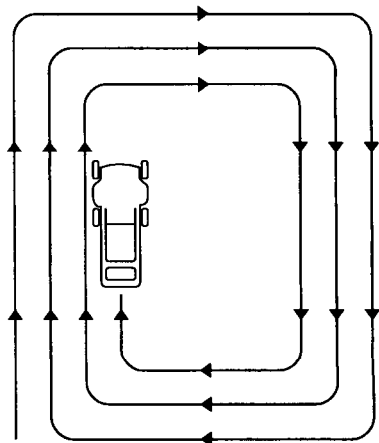

BAGGING & SIDE-DISCHARGE PATTERN

TRANSPORTING

This chapter explains how to load and carry your mower safely.

BEFORE LOADING	42
LOADING AND UNLOADING	42

TRANSPORTING

BEFORE LOADING

If the engine has been running, allow it to cool for at least 15 minutes before loading the mower on the transport vehicle. A hot engine and exhaust system can burn you and can ignite some materials.

1. Turn the fuel valve to the OFF position. This will prevent carburetor flooding and reduce the possibility of fuel leakage.

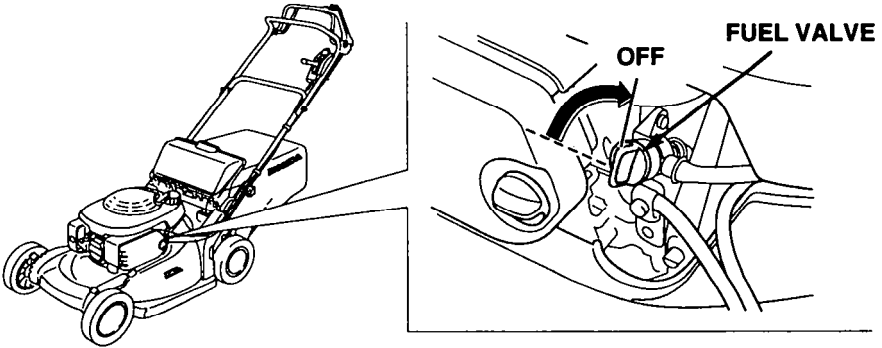

2. If equipped, remove grass bag.

LOADING AND UNLOADING

If a suitable loading ramp is not available, two people should lift the mower on and off the transport vehicle while holding the mower level.

Position the mower so all four wheels are on the bed of the transport vehicle. Tie the mower down with rope or straps, and block the wheels. Keep the tie-down rope or straps away from the controls, adjustment levers, cables, and the carburetor.

The handlebar can be folded so the mower will take up less space (see page 75).

MAINTENANCE

This chapter explains when and how to perform routine inspection, service, and adjustments for do-it-yourself maintenance. More difficult maintenance tasks should be done by your dealer. Your dealer is best equipped and staffed to provide the level of service and safety you and your mower deserve.

THE IMPORTANCE OF MAINTENANCE	44
MAINTENANCE SAFETY	45
Safety Precautions	45
EMISSION CONTROL SYSTEM INFORMATION	46
Source of Emissions	46
The U.S. and California Clean Air Acts	46
Tampering and Altering	46
Problems that may Affect Emissions	46
Replacement Parts	47
Maintenance	47
MAINTENANCE SCHEDULE	48
ENGINE MAINTENANCE	49
Engine Oil Change	49
Engine Oil Recommendations	50
Air Cleaner Service	51
Spark Plug Service	52
Carburetor Adjustment	54
Carburetor Modification for High Altitude Operation	54
Fuel Recommendations	55
CONTROL CABLE ADJUSTMENTS	56
Blade Control Cable Adjustment	56
Drive Clutch Cable Adjustment (SXA)	57
Shift Cable Adjustment (SXA)	58
Drive Clutch Cable Adjustment (HXA)	59
THROTTLE CABLE INSPECTION	61
BLADE REMOVAL AND INSTALLATION	62
Blade Removal	62
Blade Installation	63
GRASS BAG CLEANING AND REPLACEMENT (HRB215)	64

MAINTENANCE

THE IMPORTANCE OF MAINTENANCE

Good maintenance is essential for safe, economical, and trouble-free operation. It will also help reduce air pollution.

⚠ WARNING

Improper maintenance, or failure to correct a problem before operation, can cause a malfunction in which you can be seriously hurt or killed.

Always follow the inspection and maintenance recommendations and schedules in this owner's manual.

To help you properly care for your mower, the following pages include a maintenance schedule, routine inspection procedures, and simple maintenance procedures using basic hand tools. Other service tasks that are more difficult, or require special tools, are best handled by professionals and are normally performed by a Honda technician or other qualified mechanic.

The maintenance schedule applies to normal operating conditions. If you operate your mower under severe conditions, such as sustained high-load or high-temperature operation, or use in unusually wet or dusty conditions, consult your servicing dealer for recommendations applicable to your individual needs and use.

Maintenance, replacement, or repair of the emission control devices and systems may be performed by any engine repair establishment or individual, using parts that are "certified" to EPA standards.

MAINTENANCE SAFETY

Some of the most important safety precautions follow. However, we cannot warn you of every conceivable hazard that can arise in performing maintenance. Only you can decide whether or not you should perform a given task.

⚠ WARNING

Failure to properly follow maintenance instructions and precautions can cause you to be seriously hurt or killed.

Always follow the procedures and precautions in this owner's manual.

Safety Precautions

- Make sure the engine is off before you begin any maintenance or repairs. This will eliminate several potential hazards:
 - **Carbon monoxide poisoning from engine exhaust.**
Be sure there is adequate ventilation whenever you operate the engine.
 - **Burns from hot parts.**
Let the engine and exhaust system cool before touching.
 - **Injury from moving parts.**
Do not run the engine unless instructed to do so.
- Read the instructions before you begin, and make sure you have the tools and skills required.
- To reduce the possibility of fire or explosion, be careful when working around gasoline. Use only a nonflammable solvent, not gasoline, to clean parts. Keep cigarettes, sparks, and flames away from all fuel-related parts.

Remember that an authorized Honda servicing dealer knows your mower best and is fully equipped to maintain and repair it.

To ensure the best quality and reliability, use only new, genuine Honda parts or their equivalents for repair and replacement.

MAINTENANCE

EMISSION CONTROL SYSTEM INFORMATION

Source of Emissions

The combustion process produces carbon monoxide, oxides of nitrogen, and hydrocarbons. Control of hydrocarbons and oxides of nitrogen is very important because, under certain conditions, they react to form photochemical smog when subjected to sunlight.

Carbon monoxide does not react in the same way, but it is toxic.

Honda utilizes lean carburetor settings and other systems to reduce the emissions of carbon monoxide, oxides of nitrogen, and hydrocarbons.

The U.S and California Clean Air Acts

EPA and California regulations require all manufacturers to furnish written instructions describing the operation and maintenance of emission control systems.

The following instructions and procedures must be followed in order to keep the emissions from your Honda engine within the emission standards.

Tampering and Altering

Tampering with or altering the emission control system may increase emissions beyond the legal limit. Among those acts that constitute tampering are:

- Removal or alteration of any part of the intake, fuel, or exhaust systems.
- Altering or defeating the governor linkage or speed-adjusting mechanism to cause the engine to operate outside its design parameters.

Problems that may Affect Emissions

If you are aware of any of the following symptoms, have your engine inspected and repaired by your servicing dealer.

- Hard starting or stalling after starting.
- Rough idle.
- Misfiring or backfiring under load.
- Afterburning (backfiring).
- Black exhaust smoke or high fuel consumption.

Replacement Parts

The emission control systems on your new Honda engine were designed, built, and certified to conform with EPA and California emission regulations. We recommend the use of genuine Honda parts whenever you have maintenance done. These original-design replacement parts are manufactured to the same standards as the original parts, so you can be confident of their performance. The use of replacement parts that are not of the original design and quality may impair the effectiveness of your emission control system.

A manufacturer of an aftermarket part assumes the responsibility that the part will not adversely affect emission performance. The manufacturer or rebuilder of the part must certify that use of the part will not result in a failure of the engine to comply with emission regulations.

Maintenance

Follow the maintenance schedule on page 48. Remember that this schedule is based on the assumption that your machine will be used for its designed purpose. Sustained high-load or high-temperature operation, or use in unusually wet or dusty conditions, will require more frequent service.

MAINTENANCE

MAINTENANCE SCHEDULE

ITEM	REGULAR SERVICE PERIOD (3)		Before Each Use	First 20 Hours	Every 50 Hours	Every 100 Hours	Every 300 Hours	Refer to page	
	Perform at every indicated interval								
	Blade condition and blade bolt tightness	Check	O					19 63	
	Grass bag	Check	O					24	
•	Engine oil	Check	O					20	
		Change		O		O		49	
•	Air Cleaner	Check	O					22	
		Clean			O(1)			51	
		Replace					O*(1)		
•	Spark plug	Clean-Adjust				O		52	
		Replace					O		
	Spark arrester (optional equipment)	Clean				O		92	
•	Idle speed	Check-Adjust					O(2)	54	
	Blade control mechanism	Check		O(2)		O(2)		-	
	Blade control cable	Adjust		O		O		56	
	Drive clutch cable	SXA		O		O		57	
		HXA	Adjust					59	
	Shift cable (SXA)	Adjust		O		O		58	
	Throttle cable	Adjust		O(2)		O(2)		-	
•	Valve clearance	Adjust					O(2)	-	
•	Fuel tank	Clean					O(2)	-	
•	Fuel line	Replace	Every 2 years (2)						-

- Emission related items.

* Replace the paper filter only.

(1) Service more frequently when used in dusty areas.

(2) These items should be serviced by an authorized Honda servicing dealer, unless you have the proper tools and are mechanically proficient. Refer to the Honda shop manual for service procedures.

(3) For commercial use, log hours of operation to determine proper maintenance intervals.

ENGINE MAINTENANCE

Engine Oil Change

Drain the used oil while the engine is warm. Warm oil drains quickly and completely.

1. Put the throttle lever in the STOP position and turn the fuel valve OFF. This will reduce the possibility of fuel leakage (see page 34).
2. Wipe the oil filler area clean, then remove the oil filler cap/dipstick.
3. Place a suitable container next to the mower to catch the used oil, then tilt the mower on its right side. The used oil will drain through the filler neck. Allow the oil to drain completely.

Please dispose of used motor oil and the containers in a manner that is compatible with the environment. We suggest you take it in a sealed container to your local recycling center or service station for reclamation. Do not throw it in the trash, pour it on the ground or down a drain.

4. Fill with the recommended oil. Do not overfill; measure the oil level as shown on page 50.

Engine oil capacity:
0.63 US qt (0.6 ℓ)

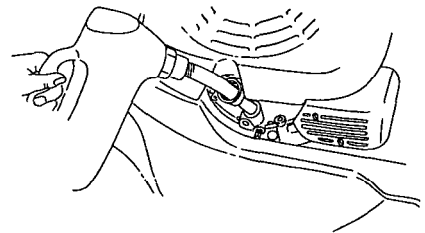
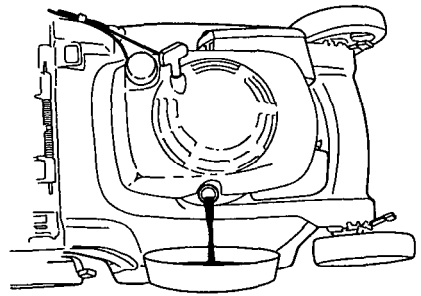

NOTICE

Using nondetergent oil can shorten the engine's service life, and using 2-stroke oil can damage the engine.

MAINTENANCE

5. After changing the engine oil, and before starting the engine, check the oil level with the mower on a level surface:

- a. Wipe the dipstick clean.
- b. Insert and remove the dipstick without screwing it into the filler neck. Check the oil level shown on the dipstick.
- c. If the oil level is low, add oil to reach the upper limit mark on the dipstick. Do not overfill. If the engine is overfilled, the excess oil may get transferred to the air cleaner housing and air cleaner filters.

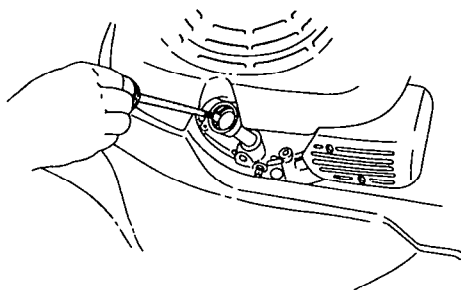

NOTICE

Running the engine with a low oil level can cause engine damage.

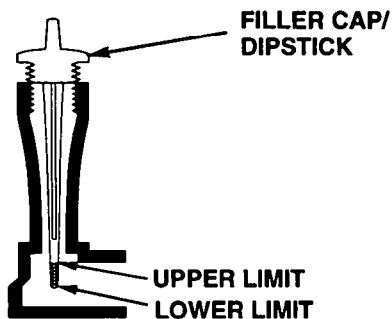

- d. Screw in the filler cap/dipstick securely.

Engine Oil Recommendations

Oil is a major factor affecting performance and service life. Use 4-stroke automotive detergent oil.

SAE 10W-30 is recommended for general use. Other viscosities shown in the chart may be used when the average temperature in your area is within the recommended range.

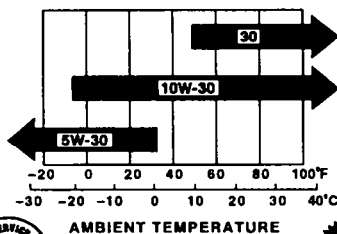

The SAE oil viscosity and service classification are in the API label on the oil container. Honda recommends that you use API SERVICE category SH or SJ oil with the ILSAC "starburst" certification mark displayed on the container.

Air Cleaner Service

Dirty air filters will restrict air flow to the carburetor, reducing engine performance. If you operate the mower in very dusty areas, clean the air filters more often than specified in the MAINTENANCE SCHEDULE.

NOTICE

Operating the engine without air filters, or with damaged filters, will allow dirt to enter the engine, causing rapid engine wear. This type of damage is not covered by the Distributor's Limited Warranty.

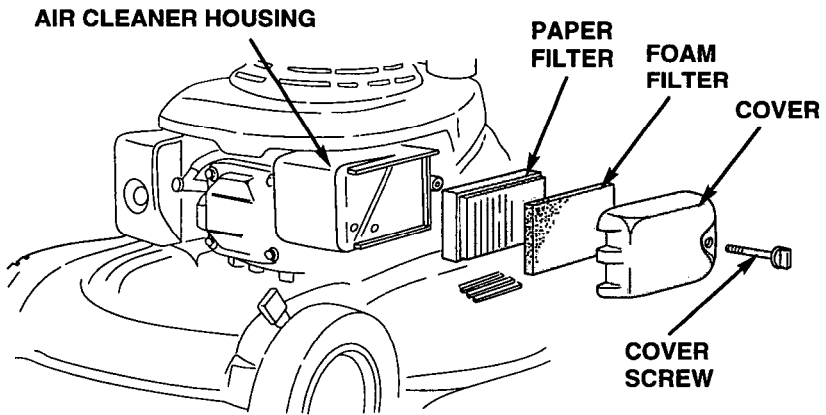

1. Unscrew and remove the air cleaner housing cover screw, then remove the air cleaner housing cover.
2. Remove the paper filter from the air cleaner housing. Remove the foam filter from the cover.
3. Inspect the filters, and replace them if they are damaged.
4. Clean the filters.

Paper filter: Tap the filter several times on a hard surface to remove dirt, or blow compressed air (not exceeding 30 psi [207 kPa]) through the filter from the inside. Never try to brush off dirt; brushing will force dirt into the fibers.

Foam filter: Clean in warm soapy water, rinse, and allow to dry thoroughly. Or clean in nonflammable solvent and allow to dry.

MAINTENANCE

5. Wipe dirt from the inside of the air cleaner housing and cover, using a moist rag. Be careful to prevent dirt from entering the air duct that leads to the carburetor.
6. Reinstall the filters and cover. Tighten the cover screw securely.

Spark Plug Service

RECOMMENDED SPARK PLUGS	REGULAR	RESISTOR*
NGK	BP5ES	BPR5ES
DENSO	W16EP-U	W16EPR-U
CHAMPION	N12Y	RN12Y

* Resistor spark plugs reduce interference with radio and TV reception.

NOTICE

Incorrect spark plugs can cause engine damage.

For good performance, the spark plug must be properly gapped and free of deposits.

1. Disconnect the spark plug cap and remove any dirt from around the spark plug area.

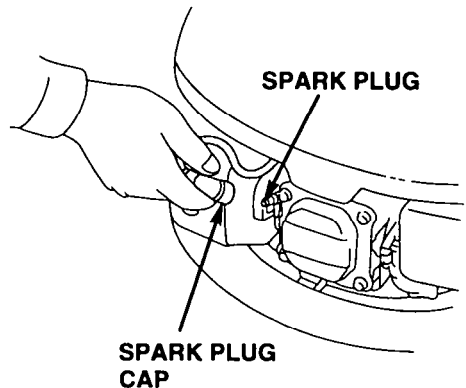

2. Remove the spark plug with a $\frac{13}{16}$ in (21 mm) spark plug wrench.
3. Inspect the spark plug. Replace it if the electrodes are worn, or if the insulator is cracked or chipped. Clean the spark plug with a wire brush if you are going to reuse it.
4. Measure the spark plug electrode gap with a suitable gauge. The gap should be 0.028 ~ 0.031 in (0.7 ~ 0.8 mm). Correct the gap, if necessary, by carefully bending the side electrode.
5. Install the spark plug carefully, by hand, to avoid cross-threading.
6. After the spark plug seats, tighten with a $\frac{13}{16}$ in (21 mm) spark plug wrench to compress the washer.

If reinstalling the old spark plug, tighten $\frac{1}{8}$ to $\frac{1}{4}$ turn after the spark plug seats.

If installing a new spark plug, tighten $\frac{1}{2}$ turn after the spark plug seats to compress the washer.

NOTICE

A loose spark plug can overheat and damage the engine. Overtightening the spark plug can damage the threads in the cylinder head.

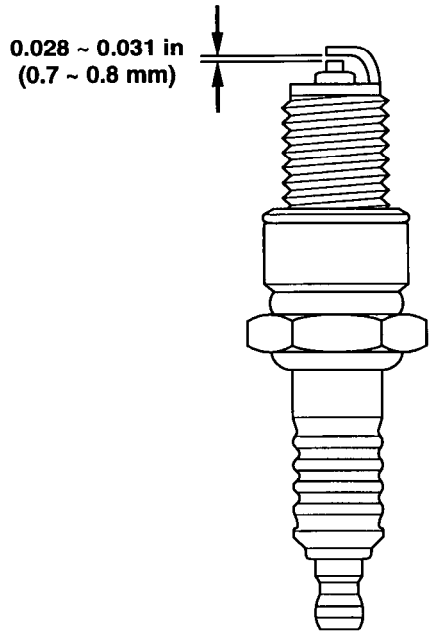
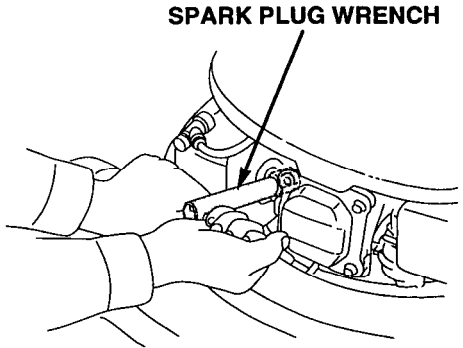

7. Install the spark plug cap on the spark plug.

MAINTENANCE

Carburetor Adjustment

1. Start the engine outdoors, and allow it to warm up to normal operating temperature.
2. Set the throttle lever in the SLOW position.
3. Turn the throttle stop screw to obtain the standard idle speed.

Standard idle speed:
2,100 ± 150 rpm

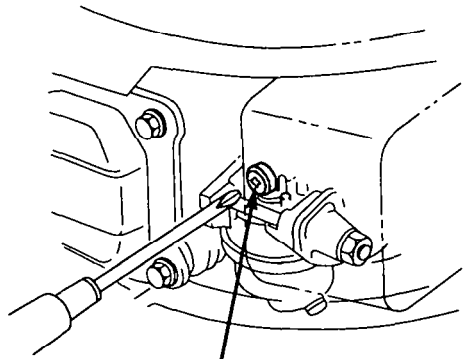

THROTTLE STOP SCREW

Carburetor Modification for High Altitude Operation

At high altitude, the standard carburetor air-fuel mixture will be too rich. Performance will decrease, and fuel consumption will increase. A very rich mixture will also foul the spark plug and cause hard starting.

High altitude performance can be improved by specific modifications to the carburetor. If you always operate your mower at altitudes above 6,000 feet (1,800 meters) have an authorized Honda servicing dealer perform this carburetor modification.

Even with carburetor modification, engine horsepower will decrease about 3.5% for each 1,000 foot (300-meter) increase in altitude. The effect of altitude on horsepower will be greater than this if no carburetor modification is made.

NOTICE

When the carburetor has been modified for high altitude operation, the air-fuel mixture will be too lean for low altitude use. Operation at altitudes below 6,000 feet (1,800 meters) with a modified carburetor may cause the engine to overheat and result in serious engine damage. For use at low altitudes, have an authorized Honda servicing dealer return the carburetor to original factory specifications.

Fuel Recommendations

Use unleaded gasoline with a pump octane rating of 86 or higher.

This engine is certified to operate on unleaded gasoline. Unleaded gasoline produces fewer engine and spark plug deposits and extends exhaust system life.

Never use stale or contaminated gasoline or an oil/gasoline mixture. Avoid getting dirt or water in the fuel tank.

Occasionally you may hear light "spark knock" or "pinging" (metallic rapping noise) while operating under heavy loads. This is no cause for concern.

If spark knock or pinging occurs at a steady engine speed, under normal load, change brands of gasoline. If spark knock or pinging persists, see an authorized Honda servicing dealer.

NOTICE

Running the engine with persistent spark knock or pinging can cause engine damage.

Running the engine with persistent spark knock or pinging is misuse, and the Distributor's Limited Warranty does not cover parts damaged by misuse.

For oxygenated fuel information refer to page 91.

MAINTENANCE

CONTROL CABLE ADJUSTMENTS

Blade Control Cable Adjustment

Measure free play at the top of the lever, while holding the button down. Free play should be $3/8 \sim 9/16$ in ($10 \sim 15$ mm). If adjustment is necessary:

1. Loosen the lock nuts with a 10 mm wrench, and move the adjuster up or down as required.
2. Tighten the lock nuts and recheck free play.
3. Start the engine outdoors, and operate the blade control lever. Check that the blade starts when you push the lever forward and stops quickly when you release the lever.

If the blade does not start or stop as it should, with correct cable adjustment, take the mower to an authorized Honda servicing dealer for repair.

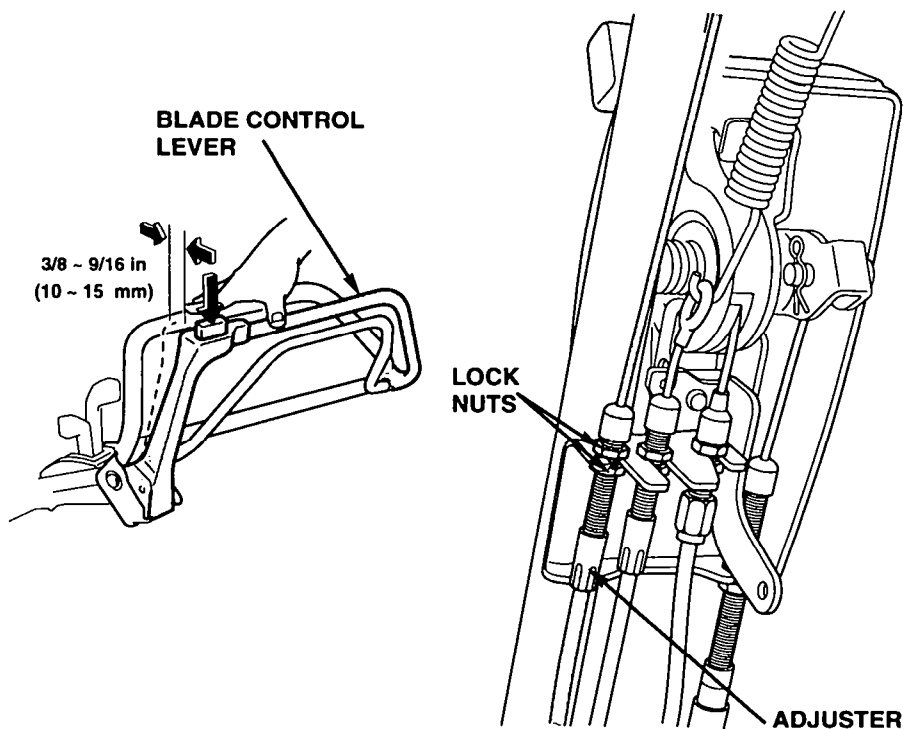

Drive Clutch Cable Adjustment (SXA)

Measure free play at the top of the lever, as shown. Free play should be $3/16 \sim 3/8$ in ($5 \sim 10$ mm). If adjustment is necessary:

1. Loosen the lock nuts with a 10 mm wrench, and move the adjuster up or down as required.
2. Tighten the lock nuts and recheck free play.
3. Start the engine outdoors, and operate the drive clutch lever. Check that the drive clutch engages and releases properly.

If the drive clutch does not operate as it should, with correct cable adjustment, take the mower to an authorized Honda servicing dealer for repair.

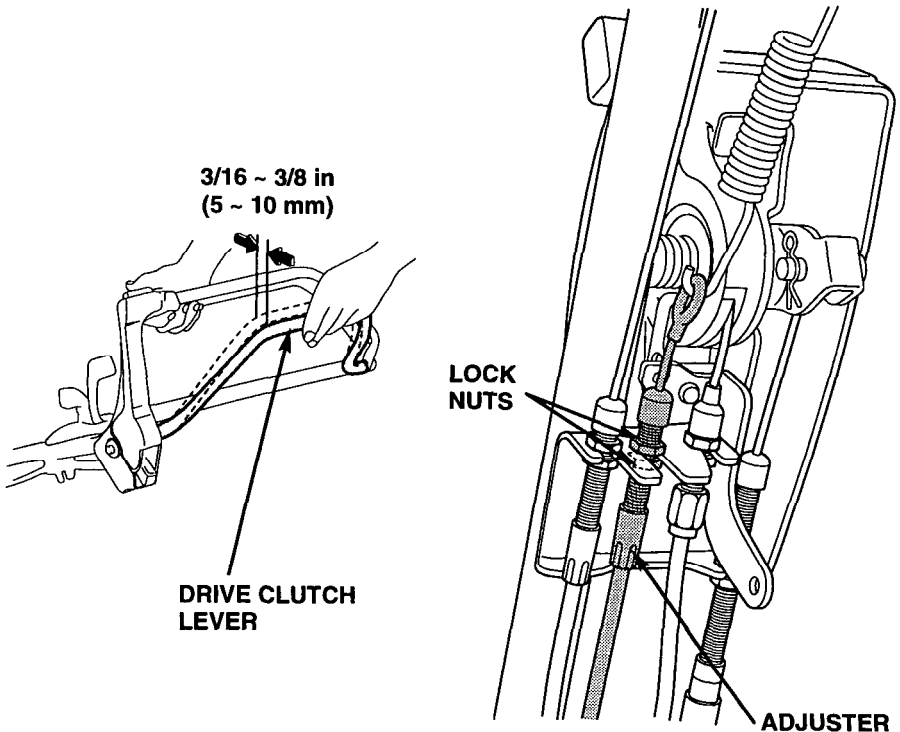

MAINTENANCE

Shift Cable Adjustment (SXA)

Shift cable adjustment is necessary if the shift lever does not operate smoothly, does not shift properly into a gear, or does not align with the numbers beside the lever.

With the shift lever in 2nd gear, check that the lever, throughout its free-play range, is well-centered on the number "2" on the lever cover. If adjustment is necessary:

1. Loosen the lock nuts with a 10 mm wrench, and move the adjuster up or down as required.
2. Tighten the lock nuts and recheck lever alignment.
3. Start the engine outdoors, and operate the shift lever (release the drive clutch lever before moving the shift lever). Check that the transmission shifts properly, and that the lever is approximately aligned with the number beside it.

If the transmission does not shift as it should with correct cable adjustment, take the mower to an authorized Honda servicing dealer for repair.

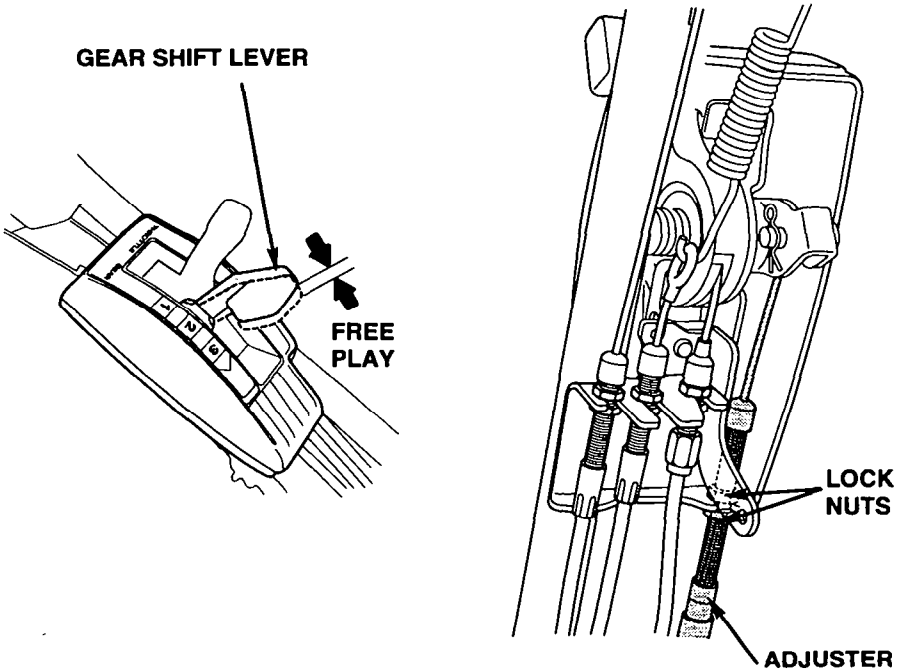

Drive Clutch Cable Adjustment (HXA)

1. With the engine stopped, position the control cable bands as shown.

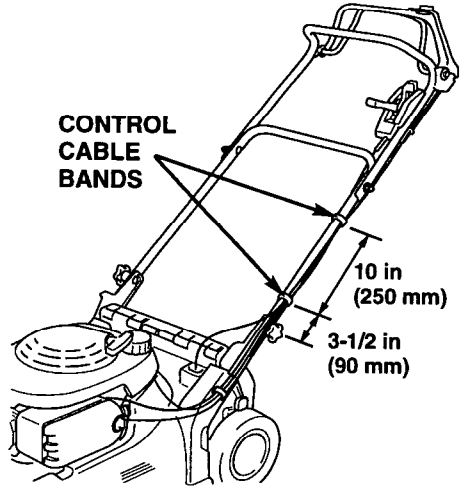

2. Pull the shift lever all the way back to the neutral position.

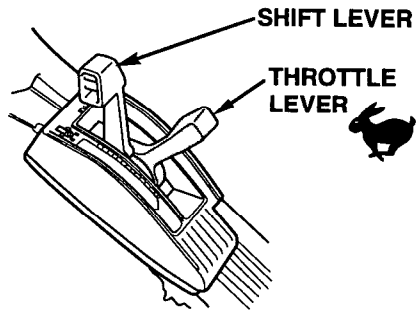

3. Start the engine and move the throttle lever to the FAST position.

4. Engage the drive clutch lever and confirm the following:
 - a. Mower does not self-propel.
 - b. Mower begins to self-propel or creeps very slowly forward when the shift lever is moved one notch forward.

If the mower does not operate as outlined above, go to step 5. If the mower does operate as outlined above, adjustment is not required.

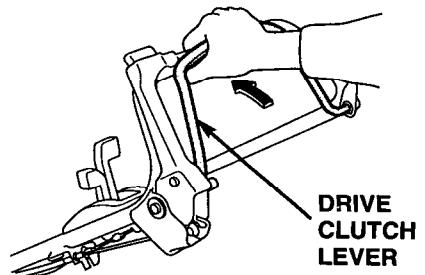

MAINTENANCE

5. Loosen the top and bottom drive clutch cable lock nuts with a 10 mm wrench. Move the adjuster up or down, as required, until the mower operates as outlined in step 4. Tighten the lock nuts.

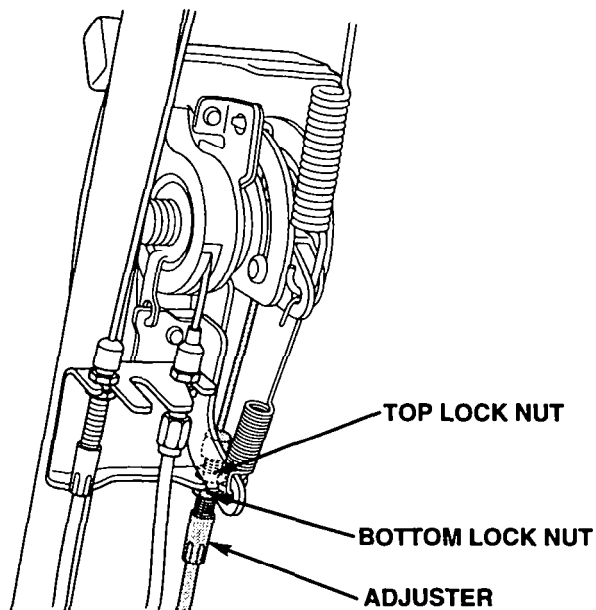

If the mower will not operate correctly, take the mower to an authorized Honda servicing dealer.

THROTTLE CABLE INSPECTION

Throttle cable adjustment is necessary if the throttle lever does not operate the choke properly.

You can inspect choke operation by observing the movement of the choke arm, which is located on top of the carburetor.

1. Move the throttle lever to the CHOKE position.

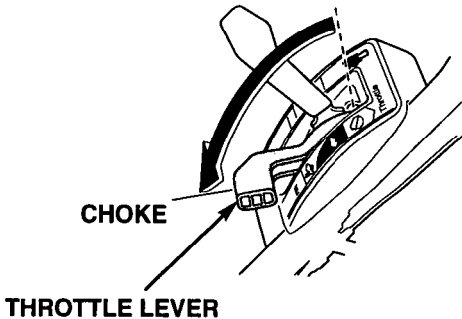

2. The choke arm should move counterclockwise, until it contacts the stop post on the carburetor.

Push the choke arm with your finger to verify that it has moved as far as it will go.

3. Move the throttle lever to the FAST position. The choke arm should move clockwise, until it contacts the stop post on the carburetor.

Push the choke arm with your finger to verify that it has moved as far as it will go.

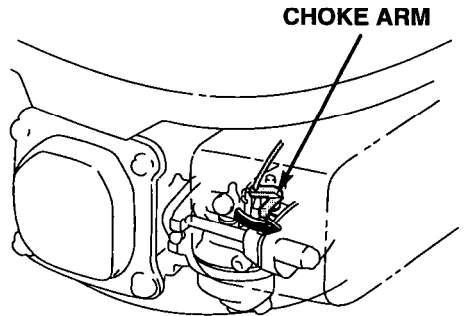

4. If the choke arm does not move all the way to its stop, in either direction, take the mower to an authorized Honda servicing dealer. Throttle cable adjustment involves related control plate adjustments.

MAINTENANCE

BLADE REMOVAL AND INSTALLATION

If you remove the blade(s) for sharpening or replacement, you will need a torque wrench for installation. Wear heavy gloves to protect your hands.

BLADE SHARPENING: To avoid weakening the blade(s), or causing imbalance or poor cutting, the blade(s) should be sharpened by trained staff at an authorized Honda servicing dealer.

BLADE REPLACEMENT: Use genuine Honda replacement blade(s) or their equivalent.

Blade Removal

1. Put the throttle lever in the STOP position and turn the fuel valve OFF. Disconnect the spark plug cap, then tilt the mower to the right side, so the carburetor side is up. This will help to prevent fuel leakage and hard starting due to carburetor flooding.
2. Remove the two blade bolts with a 14 mm socket wrench. Use a wooden block to prevent the blade(s) from turning when removing the bolts.
3. Remove the blade(s) from the blade control assembly.

UPPER MULCHING BLADE
(standard for HRM215)

BLADE BOLT (2)

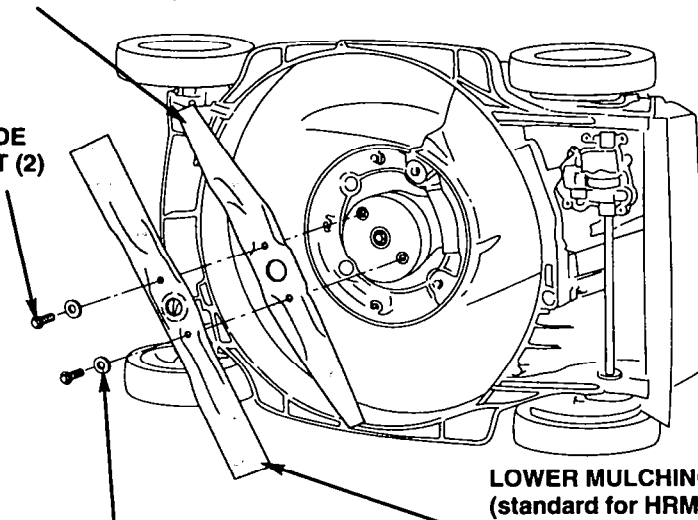

SPECIAL WASHER (2)

LOWER MULCHING BLADE
(standard for HRM215)
or
HIGH-LIFT BLADE
(standard for HRB215)

Blade Installation

1. Clean dirt and grass from around the blade mounting area.
2. Install the blade(s) using the two blade bolts and special washers as shown.

Be sure to install the special washers with the concave side toward the blade(s) and the convex side (marked OUT) toward the bolts.

The blade bolts and washers are specially designed for this application. When replacing bolts and washers, use only genuine Honda replacement parts.

3. Tighten the blade bolts with a torque wrench. Use a wooden block to prevent the blade(s) from turning when tightening the bolts.

Blade bolt torque: 36 ~ 43 ft-lb; 5.0 ~ 6.0 kg-m (49 ~ 59 N-m)

If you do not have a torque wrench, have an authorized Honda servicing dealer tighten the blade bolts before you use the mower. If the blade bolts are overtightened, they could break. If the blade bolts are not tightened enough, they could loosen or come out. In either case, it would be possible for the blade(s) to fly off while you are operating the mower.

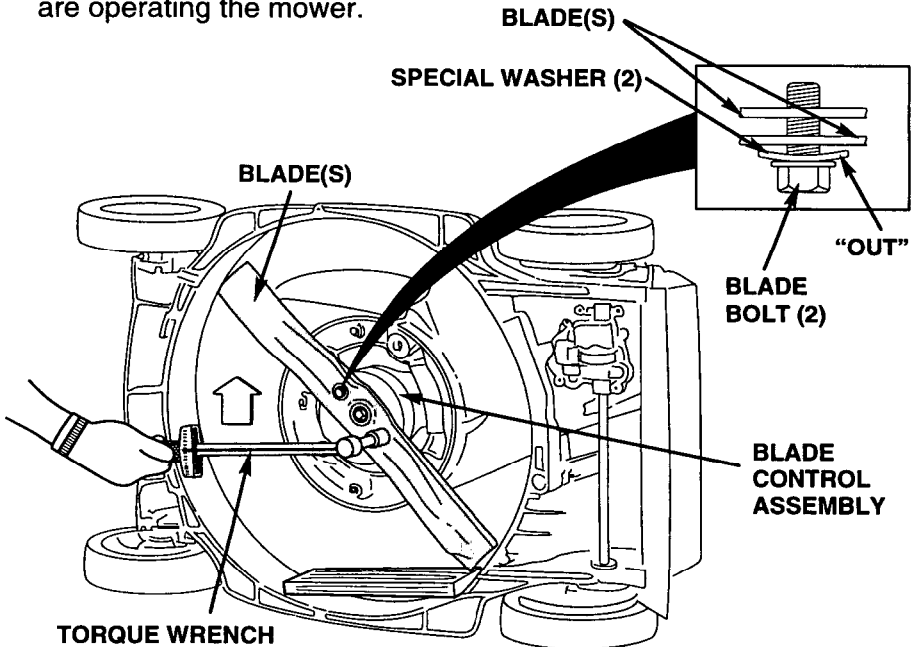

MAINTENANCE

GRASS BAG CLEANING AND REPLACEMENT (HRB215)

Grass Bag Cleaning

Wash the bag with a garden hose, and allow it to dry completely before use; a wet bag will clog quickly.

Grass Bag Replacement

Replace a worn or damaged bag with a Honda replacement bag or its equivalent.

Bag Removal

1. Unclip the plastic edges of the bag from the frame.
2. Remove the bag from the frame.

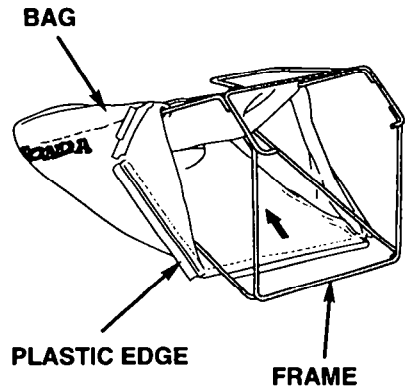

Bag Installation

1. Insert the bag frame into the bag, as shown.
2. Clip the plastic edges of the bag onto the frame, as shown.

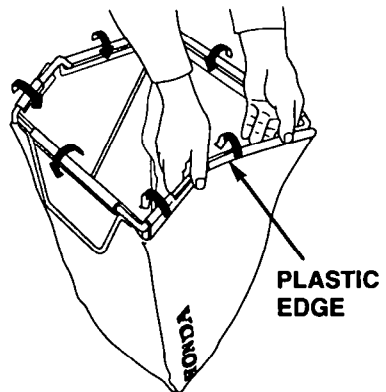

TROUBLESHOOTING

This chapter shows what to check if you have a problem with your mower.

ENGINE PROBLEMS	66
Engine will not start	66
Loss of power	66
VIBRATION PROBLEMS	67
MOWING AND BAGGING PROBLEMS	67

TROUBLESHOOTING

ENGINE PROBLEMS

Engine Will Not Start	Possible Cause	Correction
1. Check control positions.	Fuel valve OFF.	Turn fuel valve ON (p.12).
	Throttle lever in wrong position.	Move throttle lever to CHOKE position, unless the engine is warm (p. 29).
2. Check fuel.	Out of fuel.	Refuel (p. 21).
	Bad fuel; mower stored without treating or draining gasoline, or refueled with bad gasoline.	Drain fuel tank and carburetor (p. 73). Refuel with fresh gasoline (p. 21).
3. Remove and inspect spark plug.	Spark plug faulty, fouled, or improperly gapped.	Clean, gap, or replace spark plug (p. 53).
	Spark plug wet with fuel (flooded engine).	Dry and reinstall spark plug. Start engine with throttle lever in FAST position.
4. Take the mower to an authorized Honda servicing dealer, or refer to shop manual.	Fuel filter clogged, carburetor malfunction, ignition malfunction, valves stuck, etc.	Replace or repair faulty components as necessary.

Loss of Power	Possible Cause	Correction
1. Check throttle position.	Throttle not set to FAST.	Move throttle to FAST (p. 31).
2. Check grass height.	Grass too tall to cut.	Raise cutting height (p. 15), cut narrower swath (p. 37), use slower ground speed (p. 14), or cut more frequently.
3. Check under mower deck.	Mower deck clogged.	Clean out mower deck (p. 38).
4. Check air filters.	Air filters clogged.	Clean or replace air filters (p. 51).
5. Check fuel.	Bad fuel; mower stored without treating or draining gasoline, or refueled with bad gasoline.	Drain fuel tank and carburetor (p. 73). Refuel with fresh gasoline (p. 21).
6. Take mower to an authorized Honda servicing dealer, or refer to shop manual.	Fuel filter clogged, carburetor malfunction, ignition malfunction, valves stuck, etc.	Replace or repair faulty components as necessary.

VIBRATION PROBLEMS

Excessive Vibration	Possible Cause	Correction
1. Check mower deck and blade(s).	Grass and debris lodged under mower deck.	Clean out mower deck (p. 38).
	Blade(s) loose, bent, damaged, or unbalanced by improper sharpening.	Tighten loose blade(s) bolts. Replace damaged blade(s) (p. 62 - 63).
2. Take the mower to an authorized Honda servicing dealer for repair.	Mechanical damage, such as a bent crankshaft.	Replace or repair faulty components as necessary.

MOWING AND BAGGING PROBLEMS

Poor Cut Quality or Poor Mowing/Bagging Performance	Possible Cause	Correction
1. Check that the throttle lever is in the FAST position.	Engine speed is too slow to cut well.	Move throttle lever to the FAST position (p. 31).
2. Reduce forward speed.	Mower is moving too fast for lawn conditions.	Shift to slow speed (p. 33), or push slower.
3. Check cutting height adjustment levers.	Adjustment levers set at different positions.	Set all levers at the same cutting height position (p. 15).
4. Check grass bag (if equipped).	Grass bag overfilled or clogged.	Empty the grass bag. Wash the grass bag if clogged with dirt (p. 64).
5. Check mower deck and blade(s).	Mower deck clogged.	Clean out the mower deck (p. 38).
	Blade(s) dull, worn, or damaged.	Sharpen or replace blade(s) if necessary (p. 62 - 63).
	Wrong blade(s) installed.	Install correct blade(s) (p. 62 - 63).

STORAGE

This chapter explains how to protect your mower from rust and corrosion, and ensure that it will start easily when you want to use it again.

STORAGE PREPARATION	70
Cleaning	70
Engine	70
Mower Deck	70
Grass Bag (HRB215)	70
Fuel	72
Adding fuel stabilizer to extend fuel storage life.	72
Draining the Fuel Tank and Carburetor	73
Engine Oil	73
Engine Cylinder	74
Handlebar Folding	75
PLACING IN STORAGE	76
REMOVING FROM STORAGE	76

STORAGE

STORAGE PREPARATION

Proper storage preparation is essential for keeping your lawn mower troublefree and looking good. The following steps will help to keep rust and corrosion from impairing your lawn mower's function and appearance, and will make the engine easier to start when you use the lawn mower again.

Cleaning

1. Wash the lawn mower, including the underside of the mower deck.

Engine

Wash the engine by hand, and be careful to prevent water from entering the air cleaner.

NOTICE

- Using a garden hose or pressure washing equipment can force water into the air cleaner. Water in the air cleaner will soak the filters and can enter the carburetor or engine cylinder, causing damage.
- Water contacting a hot engine can cause damage. If the engine has been running, allow it to cool for at least half an hour before washing.

Mower Deck

If using a garden hose or pressure washing equipment to clean the mower deck, be careful to avoid getting water into controls and cables, or anywhere near the engine air cleaner or muffler opening.

Before washing the underside of the mower deck, be sure the throttle lever is in the OFF position and the fuel valve is in the OFF position. Disconnect the spark plug cap. Rest the mower on its right side, so the carburetor side is up. This will help to prevent fuel leakage and hard starting due to carburetor flooding. Wear heavy gloves to protect your hands from the blade(s).

Grass Bag (HRB215)

Remove the bag from the mower, and wash it with a garden hose or pressure washing equipment. Allow the bag to dry completely before storage.

2. After washing the lawn mower, wipe dry all accessible surfaces.

3. With the mower in an upright position, start the engine outdoors, and let it run until it reaches normal operating temperature to evaporate any water remaining on the engine.
4. While the engine is running, operate the blade control lever 4 or 5 times to expel water from the blade control mechanism. Allow the blade(s) to spin for several minutes to ensure that no water remains.
5. Stop the engine and allow it to cool.
6. After the lawn mower is clean and dry, touch up any damaged paint, and coat other areas that may rust with a light film of oil. Lubricate the control cable cores with a silicone spray lubricant.

STORAGE

Fuel

Gasoline will oxidize and deteriorate in storage. Old gasoline will cause hard starting, and it leaves gum deposits that clog the fuel system. If the gasoline in your mower deteriorates during storage, you may need to have the carburetor and other fuel system components, serviced or replaced.

The length of time that gasoline can be left in your fuel tank and carburetor without causing functional problems will vary with such factors as gasoline blend, your storage temperatures, and whether the fuel tank is partially or completely filled. The air in a partially filled fuel tank promotes fuel deterioration. Very warm storage temperatures accelerate fuel deterioration. Fuel deterioration problems may occur within a few months, or even less if the gasoline was not fresh when you filled the fuel tank.

The Distributor's Limited Warranty does not cover fuel system damage or engine performance problems resulting from neglected storage preparation.

You can extend fuel storage life by adding a gasoline stabilizer that is formulated for that purpose, or you can avoid fuel deterioration problems by draining the fuel tank and carburetor.

Adding fuel stabilizer to extend fuel storage life

When adding a fuel stabilizer, fill the fuel tank with fresh gasoline. If only partially filled, air in the tank will promote fuel deterioration during storage. If you keep a container of gasoline for refueling, be sure that it contains only fresh gasoline.

1. Add fuel stabilizer following the manufacturer's instructions.
2. After adding a fuel stabilizer, run the engine outdoors for 10 minutes to be sure that treated gasoline has replaced the untreated gasoline in the carburetor.
3. Move the throttle lever to the STOP position. Turn the fuel valve to the OFF position (see page 12).

Draining the Fuel Tank and Carburetor

1. Remove the carburetor drain bolt with a 10 mm wrench, and drain the carburetor bowl fuel into an approved container.

⚠ WARNING

Gasoline is highly flammable and explosive.

You can be burned or seriously injured when handling fuel.

- Stop engine and keep heat, sparks, and flame away.
- Handle fuel only outdoors.
- Wipe up spills immediately.

2. Turn the fuel valve ON (see page 12). This will allow fuel in the fuel tank to drain through the carburetor bowl.

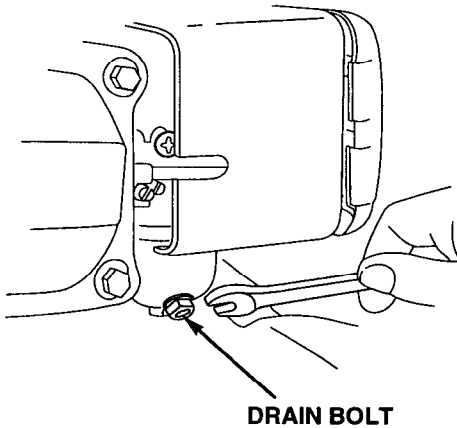

3. After the fuel is completely drained, reinstall the drain bolt.

Engine Oil

Change the engine oil (see page 49).

STORAGE

Engine Cylinder

Remove the spark plug (see page 53). Pour a tablespoon (5 ~ 10 cc) of clean engine oil into the cylinder. Pull the starter rope several times to distribute the oil in the cylinder. Reinstall the spark plug.

Pull the starter rope slowly until resistance is felt then return the starter grip gently. This will close the valves so moisture can not enter the engine cylinder.

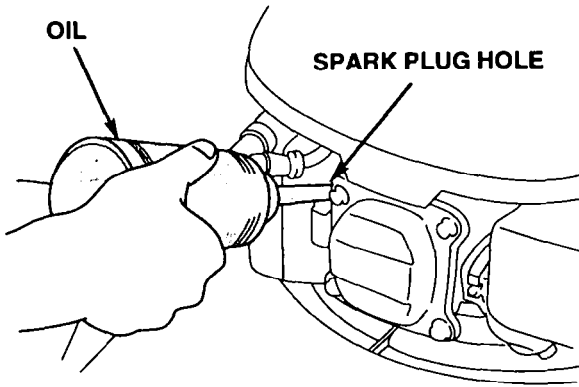

Handlebar Folding

The handlebar can be folded for storage or transport by loosening the handlebar locking knobs.

1. Remove the grass bag, if so equipped. You can place it on top of the engine, with the bag opening to the front.
2. Loosen the handlebar locking knobs. Spread the handlebar struts to release the locating pins, then swing the handlebar forward. Prevent the cables from getting pinched or kinked.

When unfolding the handlebar, be sure to tighten the locking knobs to secure the handlebar in the mowing position.

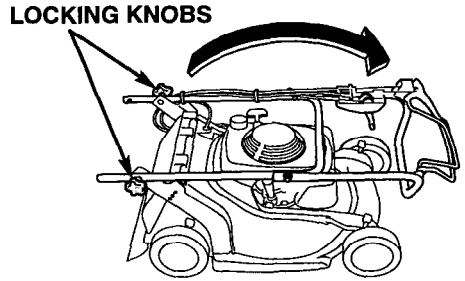

STORAGE

PLACING IN STORAGE

If your mower will be stored with gasoline in the fuel tank and carburetor, it is important to reduce the hazard of gasoline vapor ignition. Select a well-ventilated storage area away from any appliance that operates with a flame, such as a furnace, water heater, or clothes dryer. Also avoid any area with a spark-producing electric motor, or where power tools are operated.

If possible, avoid storage areas with high humidity, because that promotes rust and corrosion.

Unless all fuel has been drained from the fuel tank, turn the fuel valve to the OFF position to close the fuel valve and reduce the possibility of fuel leakage.

Place the mower with its wheels on a level surface. Tilting can cause fuel or oil leakage.

The handlebar can be folded for compact storage (see page 75).

With the engine and exhaust system cool, cover the mower to keep out dust. A hot engine and exhaust system can ignite or melt some materials. Do not use sheet plastic as a dust cover. A nonporous cover will trap moisture around the mower, promoting rust and corrosion.

REMOVING FROM STORAGE

Check your mower as described in the BEFORE OPERATION chapter of this manual.

If the fuel was drained during storage preparation, fill the tank with fresh gasoline. If you keep a container of gasoline for refueling, be sure that it contains only fresh gasoline. Gasoline oxidizes and deteriorates over time, causing hard starting.

If the cylinder was coated with oil during storage preparation, the engine will smoke briefly at startup. This is normal.

SPECIFICATIONS

This chapter gives dimensions, capacities, and other technical information.

MOWER MODELS	78
DIMENSION, WEIGHTS, AND CAPACITIES	78
ENGINE DESIGN AND PERFORMANCE	79
TRANSMISSION DESIGN AND PERFORMANCE	79
MAINTENANCE	80
TUNEUP	80

SPECIFICATIONS

MOWER MODELS

HRB215K3SXA: Self-propelled, high-lift blade and grass bag

HRB215K3HXA: Self-propelled, hydrostatic transmission, high-lift blade, and grass bag

HRM215K3SXA: Self-propelled, mulching blade and mulching plug

HRM215K3HXA: Self-propelled, hydrostatic transmission, mulching blade and mulching plug

DIMENSIONS, WEIGHTS, AND CAPACITIES

Maximum Length (handlebar extended)	Handlebar high: 59-5/8 in (1,515 mm) Handlebar mid: 62-9/16 in (1,590 mm) Handlebar low: 66-5/16 in (1,685 mm)
Minimum Length (handlebar folded)	46-7/16 in (1180 mm)
Width at Mower Deck	23-1/4 in (590 mm)
Overall Height (with cutting height set at 2-1/2 in [64 mm])	Handlebar high: 46-7/8 in (1,190 mm) Handlebar mid: 44-1/8 in (1,120 mm) Handlebar low: 39-3/8 in (1,000 mm) Handlebar folded: 20-1/16 in (510 mm)
Dry Weight	SXA: 88.2 lb (40.0 kg) HXA: 90.4 lb (41.0 kg)
Cutting Width	21 in (530 mm)
Approximate Cutting Height (adjustable)	HRB215: 3/4 in (19 mm), 1 in (25 mm), 1-1/2 in (38 mm), 2 in (51 mm), 2-1/2 in (64 mm), 3 in (77 mm) HRM215: 1 in (25 mm), 1-1/2 in (38 mm), 2 in (51 mm), 2-1/2 in (64 mm), 3 in (77 mm), 3-1/2 in (90 mm)
Fuel Tank Capacity	0.26 US gal (1.0 ℓ)
Engine Oil Capacity	0.63 US qt (0.6 ℓ)
Transmission Fluid Capacity	HXA: 4.7 fl oz (140 cc) SXA: 3.0 fl oz (90 cc)
Grass Bag Capacity (HRB)	21.9 US gal (2.4 bushels; 2.9 cu ft; 83 ℓ)

ENGINE DESIGN AND PERFORMANCE

Engine Model	GXV140K1
Engine Type	4-stroke, overhead-valve, single-cylinder, forced air-cooled
Displacement	8.2 cu in (135 cc)
Bore and Stroke	2.52 x 1.65 in (64 x 42 mm)
Compression Ratio	8:1
Ignition System	Transistorized magneto
Maximum Horsepower	5.0 bhp (3.7 kW) at 3,600 rpm
Maximum Torque	7.6 ft-lb (10.3 N·m) at 2,700 rpm

TRANSMISSION DESIGN AND PERFORMANCE

HRB215SXA & HRM215SXA

Transmission Type	3 speed, manual shift
Mower Ground Speed (with engine at 3,300 rpm)	1 (slow): 2.0 mph (3.2 km/h) 2 (medium): 3.1 mph (5.0 km/h) 3 (fast): 3.6 mph (5.8 km/h)

HRB215HXA & HRM215HXA

Transmission Type	Hydrostatic
Maximum Mower Ground Speed (with engine at 3,300 rpm)	3.2 – 3.8 mph (5.2 – 6.1 km/h)

SPECIFICATIONS

MAINTENANCE

Fuel	Unleaded gasoline with a pump octane rating of 86 or higher	See page 55.
Engine Oil	SAE 10W-30, API SH or SJ	See page 50.
Transmission Oil	HXA: Honda hydrostatic fluid SXA: NLGI #2 Grease	See shop manual.
Spark Plug Type	Regular: NGK – BP5ES DENSO – W16EP-U CHAMPION – N12Y Resistor: NGK – BPR5ES DENSO – W16EPR-U CHAMPION – RN12Y	See page 52.
Maximum Governed Speed	3,150 ~ 3,300 rpm	See shop manual.
Blade Control Cable	Adjust for 3/8–9/16 in (10~15 mm) free play at blade control lever.	See page 56.
Drive Clutch Cable (SXA)	Adjust for 3/16–3/8 in (5~10 mm) free play at drive clutch lever.	See page 57.
Shift Cable (SXA)	Adjust for proper operation.	See page 58.
Drive Clutch Cable (HXA)	Adjust for proper operation.	See page 59.
Throttle Cable	Adjust for proper choke operation and maximum governed speed.	See shop manual.
Blade Bolt Torque	36 ~ 43 ft-lb; 5.0 ~ 6.0 kg-m (49 ~ 59 N·m)	See page 63.

TUNEUP

Spark Plug Gap	0.028 ~ 0.031 in (0.7 ~ 0.8 mm)	See page 53.
Idle Speed (blade control disengaged)	2,100 ± 150 rpm	See page 54.
Valve Clearance (cold)	Intake: 0.15 ± 0.02 mm Exhaust: 0.20 ± 0.02 mm	See shop manual.
Other Specifications	No other adjustments needed.	

ADDITIONAL INFORMATION

This chapter contains additional information, Honda publications available to you, warranty, and tells you how to contact us if you have a question or a warranty repair problem.

HONDA PUBLICATIONS	82
Shop Manual	82
Parts Catalog	82
WARRANTY	83
Distributor's Limited Warranty	83
Accessories, Replacement Parts, and Apparel Warranty	85
Emission Control System Warranty	87
Warranty Service Information	90
OXYGENATED FUELS	91
SPARK ARRESTER SERVICE (optional equipment) ...	92

ADDITIONAL INFORMATION

HONDA PUBLICATIONS

These publications will give you additional information for maintaining and repairing your mower. You may order them from your Honda lawn mower dealer.

Shop Manual

This manual covers complete maintenance and overhaul procedures. It is intended to be used by a skilled technician.

Parts Catalog

This manual provides complete, illustrated parts lists.

WARRANTY

Distributor's Limited Warranty

PRODUCTS COVERED BY THIS WARRANTY:	LENGTH OF WARRANTY:* (from date of original retail purchase)	
	Noncommercial/Nonrental	Commercial/Rental
Harmony Lawn Mowers	24 months	3 months
Harmony II Lawn Mowers	24 months	3 months
Harmony Riding Mowers	24 months	3 months
Harmony Lawn Tractors	24 months	3 months
Attachments for above products	24 months	3 months

*LENGTH OF WARRANTY: Batteries supplied with applicable products as standard, original equipment are covered by this warranty for a period of 12 months (noncommercial use) or 3 months (commercial/rental use) from the date of original retail product purchase.

To Qualify for this Warranty:

The product must be purchased in the United States, Puerto Rico, or the U.S. Virgin Islands from American Honda or a dealer authorized by American Honda to sell those products. This warranty applies to first retail purchaser and each subsequent owner during the applicable warranty time period.

What American Honda will Repair or Replace Under Warranty:

American Honda will repair or replace, at its option, any part that is proven to be defective in material or workmanship under normal use during the applicable warranty time period. Warranty repairs and replacements will be made without charge for parts or labor. Anything replaced under warranty becomes the property of American Honda Motor Company, Inc. All parts replaced under warranty will be considered as part of the original product and any warranty on those parts will expire coincident with the original product warranty.

To Obtain Warranty Service:

You must take the Honda Harmony lawn mower, riding mower, or lawn tractor and proof of original retail purchase date, at your expense, to any Honda Power Equipment dealer in the United States, Puerto Rico, or the U.S. Virgin Islands who is authorized to service that product, during the dealer's normal business hours. If you are unable to obtain warranty service, or are dissatisfied with the warranty service you receive, take the following steps: First, contact the owner of the dealership involved; normally this should resolve the problem. However, if you should require further assistance, write or call the Power Equipment Customer Relations Department of American Honda Motor Co., Inc. Refer to page 90 for contact information.

ADDITIONAL INFORMATION

Exclusions:

THIS WARRANTY DOES NOT EXTEND TO PARTS AFFECTED OR DAMAGED BY ACCIDENT AND/OR COLLISION, NORMAL WEAR, FUEL CONTAMINATION, USE IN AN APPLICATION FOR WHICH THE PRODUCT WAS NOT DESIGNED OR ANY OTHER MISUSE, NEGLIGENCE, INCORPORATION OR USE OF UNSUITABLE ATTACHMENTS OR PARTS, UNAUTHORIZED ALTERATION, OR ANY CAUSES OTHER THAN DEFECTS IN MATERIAL OR WORKMANSHIP OF THE PRODUCT.

MOWER BLADES AND MOWER DECK HOUSINGS, ARE SPECIFICALLY NOT WARRANTED AGAINST DAMAGE, INCLUDING BUT NOT LIMITED TO, ABRASIVE DAMAGE.

Disclaimer of Consequential Damage and Limitation of Implied Warranties:

AMERICAN HONDA DISCLAIMS ANY RESPONSIBILITY FOR LOSS OF TIME OR USE OF THE PRODUCT, TRANSPORTATION, COMMERCIAL LOSS, OR ANY OTHER INCIDENTAL OR CONSEQUENTIAL DAMAGE. ANY IMPLIED WARRANTIES ARE LIMITED TO THE DURATION OF THIS WRITTEN LIMITED WARRANTY. Some states do not allow limitations on how long an implied warranty lasts and/or do not allow the exclusion or limitation of incidental or consequential damages, so the above exclusions and limitations may not apply to you.

This warranty gives you specific legal rights, and you may also have other rights which vary from state to state.

ADDITIONAL INFORMATION

Accessories, Replacement Parts, and Apparel Warranty

PRODUCTS COVERED BY THIS WARRANTY:	LENGTH OF WARRANTY:*((from date of original retail purchase)	
	Noncommercial/Nonrental	Commercial/Rental
Accessories	12 months	3 months
Replacement Parts	6 months	3 months
Apparel	6 months	3 months

To Qualify for this Warranty:

1. The accessories, replacement parts, or apparel must be purchased in the United States, Puerto Rico, or the U.S. Virgin Islands from American Honda or a dealer authorized by American Honda to sell those products.
2. You must be the first retail purchaser. This warranty is not transferable to subsequent owners.

What American Honda will Repair or Replace Under Warranty:

American Honda will repair or replace, at its option, any power equipment accessories, replacement parts, or apparel that are proven to be defective in material or workmanship under normal use during the applicable warranty time period. Anything replaced under warranty becomes the property of American Honda Motor Company, Inc. All parts replaced under warranty will be considered as part of the original product and any warranty on those parts will expire coincident with the original product warranty.

Accessories and replacement parts, installed by a dealer who is authorized by American Honda to sell them, will be repaired or replaced under warranty without charge for parts or labor. If installed by anyone else, accessories and replacement parts will be repaired or replaced under warranty without charge for parts, but any labor charges will be the responsibility of the purchaser.

Apparel will be repaired or replaced under warranty without any charge.

To Obtain Warranty Service:

You must take the Honda Power Equipment accessory, replacement part, apparel or the power equipment on which the accessory or replacement part is installed, and proof of purchase, at your expense, to any Honda Power Equipment dealer in the United States, Puerto Rico, or the U.S. Virgin Islands who is authorized to service that product, during the dealer's normal business hours. If you are unable to obtain warranty service, or are dissatisfied with the warranty service you receive, take the following steps: First, contact the owner of the dealership involved; normally this will resolve the problem. However, if you should require further assistance, write or call the Power Equipment Customer Relations Department of American Honda Motor Co., Inc. Refer to page 90 for contact information.

ADDITIONAL INFORMATION

Exclusions:

THIS WARRANTY DOES NOT EXTEND TO ACCESSORIES, PARTS, OR APPAREL AFFECTED OR DAMAGED BY ACCIDENT AND/OR COLLISION, NORMAL WEAR, USE IN AN APPLICATION FOR WHICH THE PRODUCT WAS NOT DESIGNED OR ANY OTHER MISUSE, NEGLIGENCE, INCORPORATION OR USE OF UNSUITABLE ATTACHMENTS OR PARTS, UNAUTHORIZED ALTERATION, IMPROPER INSTALLATION, OR ANY CAUSES OTHER THAN DEFECTS IN MATERIAL OR WORKMANSHIP OF THE PRODUCT.

MOWER BLADES AND MOWER DECK HOUSINGS, ARE SPECIFICALLY NOT WARRANTED AGAINST DAMAGE, INCLUDING BUT NOT LIMITED TO, ABRASIVE DAMAGE.

Disclaimer of Consequential Damage and Limitation of Implied Warranties:

AMERICAN HONDA DISCLAIMS ANY RESPONSIBILITY FOR LOSS OF TIME OR USE OF THE PRODUCT, OR THE POWER EQUIPMENT ON WHICH THE PRODUCT IS INSTALLED, TRANSPORTATION, COMMERCIAL LOSS, OR ANY OTHER INCIDENTAL OR CONSEQUENTIAL DAMAGE. ANY IMPLIED WARRANTIES ARE LIMITED TO THE DURATION OF THIS WRITTEN WARRANTY. Some states do not allow limitations on how long an implied warranty lasts and/or do not allow the exclusion or limitation of incidental or consequential damages, so the above exclusions and limitations may not apply to you.

This warranty gives you specific legal rights, and you may also have other rights which vary from state to state.

Emission Control System Warranty

Your new Honda Power Equipment engine complies with both the U.S. EPA and State of California emission regulations. American Honda provides the same emission warranty coverage for engines sold in all 50 states.

Your Warranty Rights And Obligations:

California

The California Air Resources Board and American Honda Motor Co., Inc. are pleased to explain the emission control system warranty on your Honda Power Equipment engine. In California, new utility and lawn and garden equipment engines must be designed, built and equipped to meet the State's stringent anti-smog standards.

Other States

In other areas of the United States your engine must be designed, built, and equipped to meet the U.S. EPA Phase I Emission standard for spark ignited engines at or below 19 kilowatts.

All States

American Honda Motor Co., Inc. must warrant the emission control system on your power equipment engine for the period of time listed below provided there has been no abuse, neglect or improper maintenance of your power equipment engine. Where a warrantable condition exists, American Honda Motor Co., Inc. will repair your power equipment engine at no cost to you including diagnosis, parts and labor.

Your emission control system may include such parts as the carburetor or fuel injection system, the ignition system, and catalytic converter. Also included may be hoses, connectors and other emission-related assemblies.

Manufacturer's Warranty Coverage:

The 1995 and later power equipment engines are warranted for two years. If any emission-related part on your engine is defective, the part will be repaired or replaced by American Honda Motor Co., Inc.

Owner's Warranty Responsibility:

As the power equipment engine owner, you are responsible for the performance of the required maintenance listed in your owner's manual. American Honda Motor Co., Inc. recommends that you retain all receipts covering maintenance on your power equipment engine, but American Honda Motor Co., Inc. cannot deny warranty coverage solely for the lack of receipts or for your failure to ensure the performance of all scheduled maintenance.

As the power equipment engine owner, you should however be aware that American Honda Motor Co., Inc. may deny you warranty coverage if your power equipment engine or a part has failed due to abuse, neglect, improper maintenance, or unapproved modifications.

You are responsible for presenting your power equipment engine to a Honda Power Equipment dealer as soon as a problem exists. The warranty repairs should be completed in a reasonable amount of time, not to exceed 30 days.

If you have any questions regarding your warranty rights and responsibilities, you should write or call the Honda Power Equipment Customer Relations Department. Refer to page 90 for contact information.

ADDITIONAL INFORMATION

Warranty Coverage:

Honda power equipment engines manufactured after January 1, 1995 and sold in the State of California, and U.S. EPA certified engines manufactured on or after September 1, 1996 and sold in all of the United States, are covered by this warranty for a period of two years from the date of delivery to the original retail purchaser. This warranty is transferable to each subsequent purchaser for the duration of the warranty period.

Warranty repairs will be made without charge for diagnosis, parts or labor. All defective parts replaced under this warranty become the property of American Honda Motor Co., Inc. A list of warranted parts is on the reverse side of this warranty statement. Normal maintenance items, such as spark plugs and filters, that are on the warranted parts list are warranted up to their required replacement interval only.

American Honda Motor Co., Inc. is also liable for damages to other engine components caused by a failure of any warranted part during the warranty period.

Only Honda approved replacement parts may be used in the performance of any warranty repairs and must be provided without charge to the owner. The use of replacement parts not equivalent to the original parts may impair the effectiveness of your engine emission control system. If such a replacement part is used in the repair or maintenance of your engine, and an authorized Honda dealer determines it is defective or causes a failure of a warranted part, your claim for repair of your engine may be denied. If the part in question is not related to the reason your engine requires repair, your claim will not be denied.

To Obtain Warranty Service:

You must take your Honda Power Equipment engine or the product on which it is installed, along with your warranty registration card or other proof of original purchase date, at your expense, to any Honda Power Equipment dealer who is authorized by American Honda Motor Co., Inc. to sell and service that Honda product during his normal business hours. Claims for repair or adjustment found to be caused solely by defects in material or workmanship will not be denied because the engine was not properly maintained and used.

If you are unable to obtain warranty service, or are dissatisfied with the warranty service you received, contact the owner of the dealership involved. Normally this should resolve your problem. However, if you require further assistance, write or call the Power Equipment Customer Relations Department of American Honda Motor Co., Inc.

ADDITIONAL INFORMATION

Exclusions:

FAILURES OTHER THAN THOSE RESULTING FROM DEFECTS IN MATERIAL OR WORKMANSHIP ARE NOT COVERED BY THIS WARRANTY. THIS WARRANTY DOES NOT EXTEND TO EMISSION CONTROL SYSTEMS OR PARTS WHICH ARE AFFECTED OR DAMAGED BY OWNER ABUSE, NEGLIGENCE, IMPROPER MAINTENANCE, MISUSE, MISFUELING, IMPROPER STORAGE, ACCIDENT AND/OR COLLISION, THE INCORPORATION OF, OR ANY USE OF, ANY ADD-ON OR MODIFIED PARTS, UNSUITABLE ATTACHMENTS, OR THE UNAUTHORIZED ALTERATION OF ANY PART.

THIS WARRANTY DOES NOT COVER REPLACEMENT OF EXPENDABLE MAINTENANCE ITEMS MADE IN CONNECTION WITH REQUIRED MAINTENANCE SERVICES AFTER THE ITEM'S FIRST SCHEDULED REPLACEMENT AS LISTED IN THE MAINTENANCE SECTION OF THE PRODUCT OWNER'S MANUAL, SUCH AS: SPARK PLUGS AND FILTERS.

Disclaimer of Consequential Damage and Limitation of Implied Warranties: AMERICAN HONDA MOTOR CO., INC. DISCLAIMS ANY RESPONSIBILITY FOR INCIDENTAL OR CONSEQUENTIAL DAMAGES SUCH AS LOSS OF TIME OR THE USE OF THE POWER EQUIPMENT, OR ANY COMMERCIAL LOSS DUE TO THE FAILURE OF THE EQUIPMENT; AND ANY IMPLIED WARRANTIES ARE LIMITED TO THE DURATION OF THIS WRITTEN WARRANTY. THIS WARRANTY IS APPLICABLE ONLY WHERE THE CALIFORNIA OR U.S. EPA EMISSION CONTROL SYSTEM WARRANTY REGULATION IS IN EFFECT.

Emission Control System Warranty Parts:

SYSTEMS COVERED BY THIS WARRANTY:	PARTS DESCRIPTION:
Fuel Metering	Carburetor assembly Fuel injection pump Fuel injection nozzle Fuel regulator
Exhaust System	Catalyst
Air Induction	Air filter housing Air filter element* Crankcase breather tube
Ignition	Flywheel magneto Ignition pulse generator Ignition control module Ignition coil assembly Spark plug cap Spark plug*
Miscellaneous Parts	Tubing, fittings, seals, gaskets and clamps associated with these listed systems.

* Covered up to the first required replacement only. See the maintenance schedule in the owner's manual.

ADDITIONAL INFORMATION

Warranty Service Information

Honda Power Equipment dealership personnel are trained professionals. They should be able to answer any question you may have. If you encounter a problem that your dealer does not solve to your satisfaction, please discuss it with the dealership's management. The Service Manager or General Manager can help. Almost all problems are solved in this way.

If you are dissatisfied with the decision made by the dealership's management, contact the Honda Power Equipment Customer Relations Office. You can write:

American Honda Motor Co., Inc.
Power Equipment Division
Customer Relations Office
4475 River Green Parkway
Duluth, GA 30096-2565

Or telephone: (770) 497-6400

When you write or call, please give us this information:

- Model and serial numbers (see page 11)
- Name of the dealer who sold the lawn mower to you
- Name and address of the dealer who services your lawn mower
- Date of purchase
- Your name, address, and telephone number
- A detailed description of the problem

OXYGENATED FUELS

Some conventional gasolines are being blended with alcohol or an ether compound. These gasolines are collectively referred to as oxygenated fuels. To meet clean air standards, some areas of the United States and Canada use oxygenated fuels to help reduce emissions.

If you use an oxygenated fuel, be sure it is unleaded and meets the minimum octane rating requirement.

Before using an oxygenated fuel, try to confirm the fuel's contents. Some states/provinces require this information to be posted on the pump.

The following are the EPA approved percentages of oxygenates:

ETHANOL ——— (ethyl or grain alcohol) 10% by volume
You may use gasoline containing up to 10% ethanol by volume. Gasoline containing ethanol may be marketed under the name "Gasohol".

MTBE ————— (Methyl Tertiary Butyl Ether) 15% by volume
You may use gasoline containing up to 15% MTBE by volume.

METHANOL — (methyl or wood alcohol) 5% by volume
You may use gasoline containing up to 5% methanol by volume, as long as it also contains cosolvents and corrosion inhibitors to protect the fuel system. Gasoline containing more than 5% methanol by volume may cause starting and/or performance problems. It may also damage metal, rubber, and plastic parts of your fuel system.

If you notice any undesirable operating symptoms, try another service station, or switch to another brand of gasoline.

Fuel system damage or performance problems resulting from the use of an oxygenated fuel containing more than the percentages of oxygenates mentioned above are not covered under warranty.

ADDITIONAL INFORMATION

SPARK ARRESTER SERVICE (optional equipment)

The engine in your lawn mower is not factory-equipped with a spark arrester. In some areas, it is illegal to operate an engine without a spark arrester. Check local laws and regulations. A spark arrester is available from an authorized Honda servicing dealer.

The spark arrester must be serviced every 100 hours to keep it functioning as designed.

1. Allow the engine to cool, then remove the two nuts from the muffler shield, using a 10 mm socket wrench.
2. Remove the muffler shield, identification plate, muffler, and gasket.
3. Remove the spark arrester from the muffler.
4. Check for carbon deposits on the spark arrester and the exhaust port. Brush carbon deposits away. Be careful to avoid damaging the spark arrester screen.
5. Install the spark arrester in the muffler.
6. Install the muffler components on the engine, and tighten the two nuts securely.

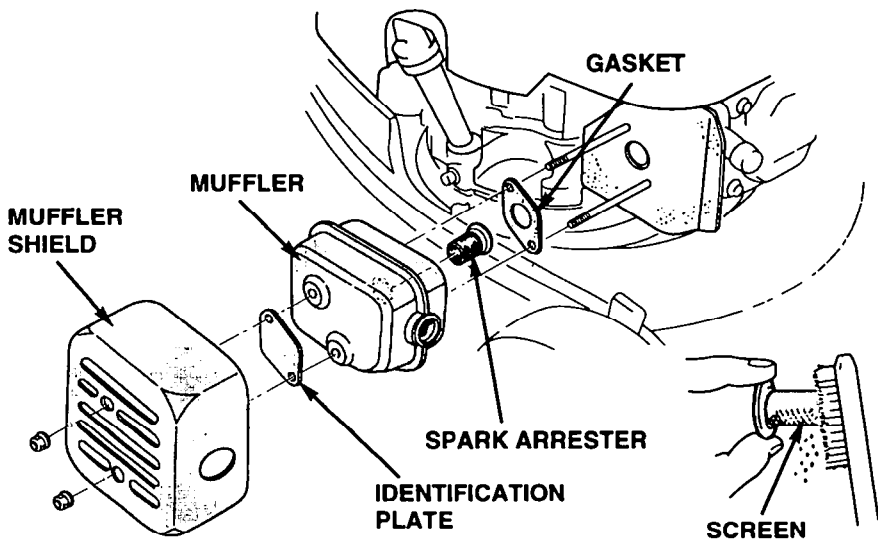

A

- Air Cleaner Inspection22
- Air Cleaner Service.....51

B

- Blade:
 - Inspection 19
 - Installation.....63
 - Removal.....62
- Blade Control Lever:
 - Cable Adjustment56
 - Operation..... 13 & 31

C

- Carburetor:
 - Adjustment.....54
 - High Altitude Operation..... 54
- Choke 12 & 29
- Clogged Mower Deck38
- Clothing Recommendations... 18
- Component Identification..... 10
- Contents 3
- Control Cable Adjustments:
 - Blade Control Cable.....56
 - Drive Clutch Cable (SXA) ..57
 - Drive Clutch Cable (HXA) ..59
 - Shift Cable (SXA).....58
- Cutting Height:
 - Adjustment Levers 15
 - Recommendations.....37
- Cutting Width
 - Recommendations.....37

D

- Damage Prevention Message
 - Definition 2
- Description of Controls 12
- Distributor's Limited
 - Warranty..... 83
- Drive Clutch Lever:
 - Cable Adjustment (SXA) ... 57
 - Cable Adjustment (HXA) ... 59
 - Operation..... 13 & 32

E

- Emission Control System
 - Information 46
- Emission Control System
 - Warranty..... 87
- Engine:
 - Fuel Recommendations 55
 - Maintenance..... 49
 - Oil Change 49
 - Oil Level 20
 - Oil Recommendations 50
 - Refueling 21
 - Serial Number 11
 - Specifications 77
 - Starting 29
 - Stopping 34
 - Troubleshooting..... 65

F

- Fallen Leaves, Bagging 38
- Frame Serial Number 11
- Fuel:
 - Additive to Extend Storage
 - Life..... 72
 - Gasoline
 - Recommendations..... 55
 - Draining 73
 - Refueling 21
 - Valve 12

INDEX

G

Gasoline Recommendations..	55
Grass Bag:	
Cleaning.....	64 & 70
Inspection.....	24
Removal and Installation....	24
Replacement.....	64

H

Handlebar Height Adj.....	23
Handlebar Folding	75
High Altitude Operation.....	54

I

Inspection Before Mowing:	
Lawn	18
Mower	19
Introduction	1

L

Lawn:	
Inspection Before Mowing..	18
Mowing Tips.....	37
Safe Mowing Practices	35
Leaves, Bagging	38

M

Maintenance:	
Blade Removal and Installation	62
Cable Adjustments	56
Engine.....	49
Grass Bag Cleaning & Replacement	64
Importance	44
Safety.....	45
Schedule	48
Specifications.....	77
Mower Deck Clogging.....	38

Mowing:

Around Obstacles, Gravel, Objects	36
Dry & Wet Grass.....	38
Fallen Leaves	38
Patterns	39
Slopes.....	35
Tips.....	37
When to Mow.....	37
Mulching Plug	25

O

Oil (for engine):	
Change	49
Level Check	20
Recommendations.....	50
Operating the Controls for Mowing	31

P

Pre-Operation Check:	
Lawn	18
Mower	19
Publications	82

S

Safety:	
Important Message to Parents	7
Safe Mowing Practices	35
Important Safety Information.....	6
Safety Label Locations	8
Safety Message Definitions	2
Serial Numbers.....	11
Shift Lever:	
Cable Adjustment (SXA)....	58
Operation.....	14 & 33

Spark Arrester Service
 (optional part).....92

Spark Plug Recommendations
 & Service52

Specifications:

- Capacities78
- Dimensions78
- Engine Design and
 Performance79
- Maintenance80
- Transmission Design and
 Performance79
- Tuneup80
- Weights.....78

Starting the Engine29

Stopping the Engine34

Storage:

- Placing in Storage.....76
- Preparation70
- Removing From Storage....76

T

Throttle Lever:

- Cable Inspection61
- Operation12 & 31

Transmission:

- Drive Clutch Cable
 Adjustment (SXA)57
- Drive Clutch Cable
 Adjustment (HXA)59
- Drive Clutch Lever
 Operation13 & 32
- Shift Lever
 Operation14 & 33
- Specifications.....77

Transporting41

Troubleshooting:

- Engine Problems66
- Mowing and Bagging
 Problems.....67
- Vibration Problems67

Tuneup Specifications 80

W

Warranty:

- Accessories, Replacement
 Parts, and Apparel 85
- Distributor's Limited 83
- Emission Control System ..87
- Service Information 90

Washing:

- Grass Bag64 & 70
- Mower.....70



QUICK REFERENCE INFORMATION

Fuel	Type	Unleaded gasoline with pump octane rating of 86 or higher (page 55).
	Capacity	0.26 US gallons (1.0 ℓ)
Engine Oil	Type	SAE 10W-30, API SH or SJ (page 50)
	Capacity	0.63 US quarts (0.6 ℓ)
Spark Plug	Type	Regular: NGK – BP5ES DENSO – W16EP-U Champion – N12Y Resistor: NGK – BPR5ES DENSO – W16EPR-U Champion – RN12Y
	Gap	0.028 ~ 0.031 in (0.7 ~ 0.8 mm) (page 53)
Blade bolts	Torque	36~43 ft-lb (5.0~6.0 kg-m, 49 ~ 59 N•m) (page 63)
Carburetor	Idle speed	2,100 ±150 rpm, blade control disengaged (page 54)
Maintenance	Before each use	Check blade(s) and bolt tightness (pages 19 & 63). Check grass bag (page 24 & 64). Check engine oil level (page 20). Check air cleaner (page 22).
	First 20 hours	Change engine oil (page 49). Check blade control mechanism (dealer service). Adjust blade control cable (page 56). Adjust SXA drive clutch cable (page 57). Adjust SXA shift cable (page 58). Adjust HXA drive clutch cable (page 59). Adjust throttle cable (dealer service).
	Subsequent	Refer to maintenance schedule on page 48.

HONDA

31VE2630
00X31-VE2-6300



Printed on
Recycled Paper



IPD

PRINTED IN U.S.A.



POM51765-CVR . . .

150009805