

OWNER'S MANUAL

**MODEL NO.
All AZ Series
Models from
Serial #
97-056001**



CAUTION:
Read and follow all
Safety Rules and
Instructions Before
Operating This
Equipment

Rev. 12.01.1997

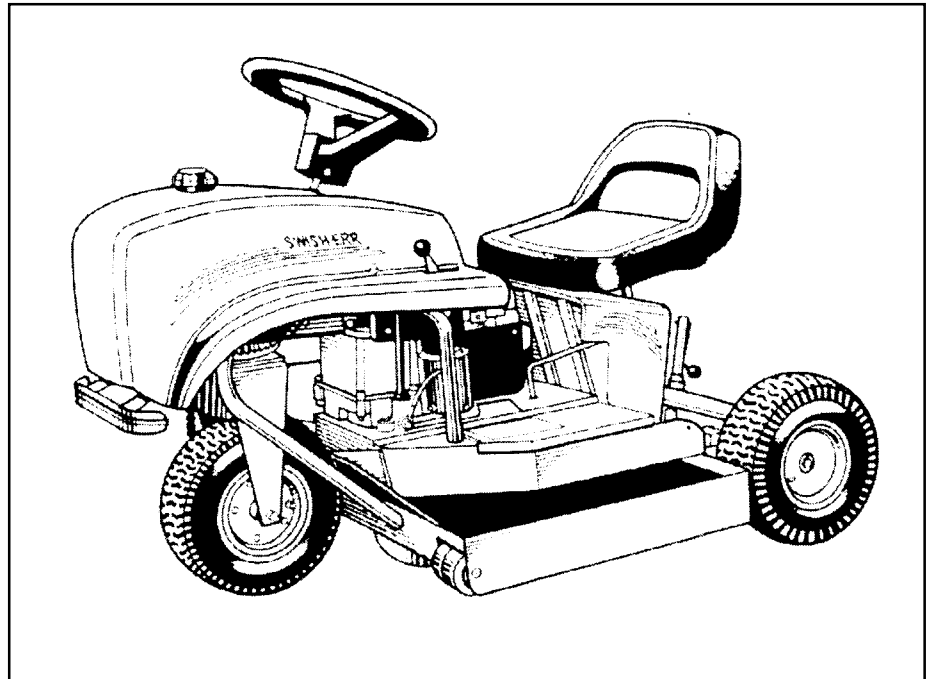

Zero Turn Riding Mowers

**Assembly
Operation
Service and Adjustment
Repair Parts**

P.O. BOX 67, WARRENSBURG, MISSOURI 64093 PHONE 660-747-8183 FAX 660-747-8650

Manufacturing quality lawn care equipment since 1945

Made In The

USA



Swisher Mower & Machine Co. Inc.

P.O. Box 67
Warrensburg, MO 64093

Phone (660) 747-8183
Toll Free (800) 222-8183
FAX (660) 747-8650

Dear Valued Customer:

All of us at our plant in Warrensburg, Missouri, are delighted that you've chosen to purchase a Swisher Zero Turn Radius Mower. We know that you will enjoy years of trouble free service and will save time and money by using our products. We regularly receive letters from satisfied riding mower customers who are still using Swisher mowers they purchased 20, even 25 years ago!

American-Made Swisher mowers feature rugged all-steel construction, and include 1/8 inch welded steel mower decks. Swisher mower decks are individually fabricated, therefore far more durable than stamped steel decks commonly found on other mowers. In addition to unsurpassed durability, their unique patented steering provides maximum maneuverability with time saving, zero-turning radius capability.

Founded a half-century ago, Swisher is a family-owned and operated company dedicated to quality and product innovation. We designed and introduced the first zero-turning radius walk-behind mower in 1945, and the first zero-turning radius riding mower in 1955...long before most other mower manufacturers began business. Our innovations have continued with popularizing the towing mower concept, solar-automated composters, rotisserie outdoor cooking and much more!

Please take the time to familiarize yourself with this owner's manual paying special attention to the safety precautions, the operation and the maintenance of your new riding mower.

We appreciate the trust you have placed in our company and our product. Thank you for your business.

Sincerely,

O. Wayne Swisher
President,
Swisher Mower and Machine Co., Inc.

TABLE OF CONTENTS

Safety Rules	2
Safety /Operational Decals	4
Assembly	6
Your New Mower	8
Before Starting Engine - Frist Time	8
Maintenance	10
Adjustments/Lubrication	11
Storing	12
Repairs	12
Mulching Mower	14
Sweeper/Collector	14
Brush Adjustments	15
Bag and Brush Replacement.....	15
Mower Installation	16
Belt Housing Illustration	17
Two Speed Pulley Illustration.....	18
Variable Speed Pulley Illustration	19
Height Adjustment Illustration	20
Blade Drive Assembly Illustration	21
Traction Assembly Illustration	22
Two Speed Pulley Assembly Illustration.....	23
Mulcher Mower Assembly Illustration	24
Wiring Diagram Illustration.....	25
Replacement Parts	26

SAFETY RULES

Safety Operation Practices for Riding Mowers

IMPORTANT: THIS CUTTING MACHINE IS CAPABLE OF AMPUTATING HANDS AND FEET, AND THROWING OBJECTS. FAILURE TO OBSERVE THE FOLLOWING SAFETY INSTRUCTIONS COULD RESULT IN SERIOUS INJURY OR DEATH.

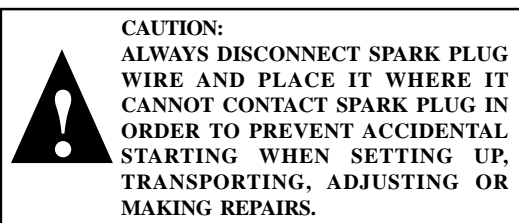
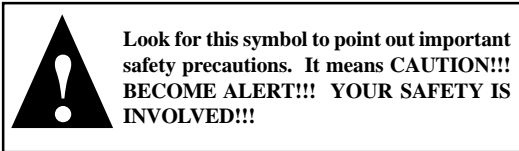

I. GENERAL OPERATION

- Read, understand, and follow all instructions in the manual and on the machine before starting.
- Read this operator's manual carefully. Become familiar with the controls and know how to operate your mower properly.
- Only allow responsible adults, who are familiar with the instructions, to operate the machine.
- Clear the area of objects such as rocks, toys, wire, etc. which could be picked up and thrown by the blade.
- Be sure the area is clear of other people before mowing. Stop machine if anyone enters the area.
- Never carry passengers.
- Do not mow in reverse unless absolutely necessary. Always look down and behind before and while backing.
- Be aware of the mower discharge direction and do not point it at anyone. Do not operate the mower without the guards in place.
- Slow down before turning.
- Never leave a running machine unattended. Always turn off blades, and stop engine.
- Turn off blades when not mowing.
- Mow only in daylight or good artificial light.
- Do not operate the machine while under the

influence of alcohol or drugs.

- Watch for traffic when operating near or crossing roadways.
- Use extra care when loading or unloading the machine into a trailer or truck.
- Disengage power to mower, stop engine when transporting or not in use.
- Exercise special care when mowing around fixed objects in order to prevent the blades from striking them. Never deliberately run tractor or mower onto or over any foreign object.
- Use mower only as the manufacturer intended and as described in the manual.
- Do not operate mower if it has been dropped or damaged in any manner. Always have damage repaired before using your mower.
- Always wear safety glasses or eye shields when starting and while using your mower.
- Dress properly. Do not operate mower when barefoot or wearing open sandals. Wear only solid shoes with good traction when mowing.
- Always make cutting height adjustments before starting your mower. Never attempt to do this while the engine is running.
- Keep your eyes and mind on your mower and the area being cut.
- Do not let other interests distract you.
- Do not put hands or feet near or under rotating parts. Keep clear of the discharge opening at all times.
- Before cleaning, inspecting, or repairing your mower, stop the engine and make absolutely sure the blade and all moving parts have stopped. Then disconnect the spark plug wire and keep it away from the spark plug to prevent accidental starting.
- Do not operate your mower if it vibrates abnormally. Excessive vibration is an indication of damage; stop the engine, safely check for the cause of vibration and repair as required.
- Never operate your mower without proper guards, plates, or other safety devices in place.

II. SLOPE OPERATION

Slopes are a major factor related to loss-of-control and tipover accidents, which can result in severe injury or death. All slopes requires extra caution. If you feel uneasy on it, do not mow it.

DO:

- Mow up and down slopes.
- Remove obstacles such as rocks, tree limbs, etc.
- Watch for holes, ruts, or bumps. Uneven terrain could overturn the machine. Tall grass can hide obstacles.
- Use slow speed. Choose a low gear so that you will not have to stop or shift while on the slope.
- Keep all movement on the slopes slow and gradual. Do not make sudden changes in speed or direction.
- Avoid starting or stopping on a slope. If tires lose traction, disengage the blades and proceed slowly straight down the slope.

DO NOT:

- Do not turn on slopes unless necessary, and then, turn slowly and gradually downhill, if possible.
- Do not mow near drop-offs, ditches, or embankments. The mower could suddenly turn over if a wheel is over the edge of a cliff or ditch, or if an edge caves in.
- Do not mow on wet grass. Reduced traction could cause sliding.

III. CHILDREN

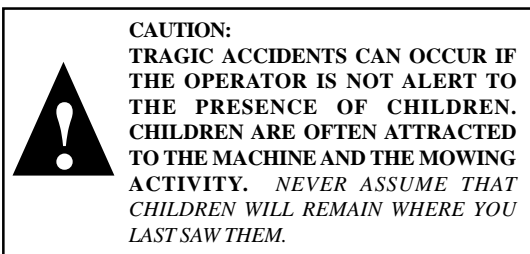

- Keep children out of the mowing area and under the watchful care of another responsible adult.
- Be alert and turn machine off if children enter the area.

- Before and when backing, look behind and down for small children.
- Never carry children. They may fall off and be seriously injured or interfere with safe machine operation.
- Never allow children to operate the machine.
- Use extra care when approaching blind corners, shrubs, trees, or other objects that may obscure vision.

IV. SERVICE

- Use extra care handling gasoline and other fuels. They are flammable and vapors are explosive.
 - Use only an approved container.
 - Never remove gas cap or add fuel with the engine running.
 - Allow engine to cool before refueling. Do not smoke.
 - Never refuel the machine indoors.
 - Never store the machine or fuel container inside where there is an open flame, such as a water heater.
- Never run a machine inside a closed area.
- Keep nuts and bolts, especially blade attachment nuts, tight and keep equipment in good condition.
- Never tamper with safety devices. Check their proper operation regularly.
- Keep machine free of grass leaves, or other debris build-up. Clean oil or fuel spillage. Allow machine to cool before storing.
- Stop and inspect the equipment if you strike an object. Repair, if necessary, before restarting.
- Never make adjustments or repairs with the engine running.
- Mower blades are sharp and can cut. Wrap the blades(s) or wear gloves, and use extra caution when servicing them.

SAFETY AND OPERATIONAL DECALS

Replace decal immediately if damaged. Order by part number from Swisher Mower and Machine Co. Inc.



WARNING

SERIOUS INJURY OR DEATH CAN OCCUR

- MOVING PARTS - SHARP BLADES - THROWN OBJECTS - POSSIBILITY OF ROLL OVER -
- GO UP AND DOWN SLOPES, NOT ACROSS.
- AVOID SUDDEN TURNS, SUDDEN CHANGES IN DIRECTION, SUDDEN CHANGES IN SPEED.
- IF MACHINE STOPS GOING UPHILL, STOP BLADE AND BACK SLOWLY DOWN.
- BE EXTRA CAUTIOUS ON ALL SLOPES AND UNEVEN SURFACES.
- DO NOT MOW WHEN CHILDREN OR OTHERS ARE AROUND.
- NEVER CARRY CHILDREN OR OTHERS AS PASSENGERS.
- LOOK DOWN AND BEHIND BEFORE AND WHILE BACKING.
- KEEP SAFETY DEVICES (GUARDS, SHIELDS, AND SWITCHES) IN PLACE AND WORKING.
- REMOVE OBJECTS THAT COULD BE THROWN BY THE BLADE.
- KNOW SAFE OPERATING INSTRUCTIONS BEFORE STARTING ENGINE.

- READ OPERATORS GUIDE FIRST -



DANGER



**SPINNING BLADE
KEEP CLEAR
CONTACT CAN INJURE**



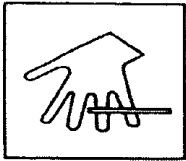

CAUTION

KEEP HANDS CLEAR
MOVING PARTS CAN
CAUSE PERSONAL INJURY

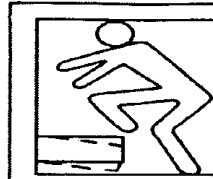

CAUTION

UNSTABLE SURFACE
NO STEP

CLUTCH LEVER FORWARD TO ENGAGE

THIS MACHINE DRIVEN
BY THE FRONT WHEEL.
BE SURE FRONT WHEEL
IS STEERED IN THE
DIRECTION INTENDED
BEFORE ENGAGING.



CAUTION

THIS DEFLECTOR MUST BE IN
PLACE BEFORE OPERATING MOWER.
KEEP ALL SHIELDS IN PLACE.



NOTICE

DO NOT ALTER ELECTRICAL SYSTEM
WRONG WIRING CONNECTIONS WILL DAMAGE
ELECTRICAL COMPONENTS AND MAY MAKE
THE SAFETY SWITCHES INOPERATIVE

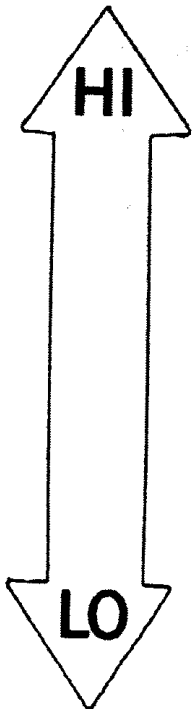
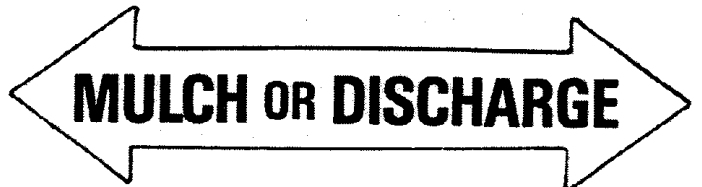

FORWARD TO ENGAGE

THIS MACHINE DRIVEN
BY THE FRONT WHEEL.
BE SURE FRONT WHEEL
IS STEERED IN THE
DIRECTION INTENDED
BEFORE ENGAGING.

IMPORTANT! - READ THIS MANUAL BEFORE OPERATING MOWER

Be sure to check your new Swisher Riding Mower for shipping damage before beginning assembly.

These parts are packaged with your new mower.

- Steering Wheel - includes one (1) 1/4-20 x 1/2" bolt, washer and cap plug
- Seat - includes two (2) 3/8" - 16 x 3/4" bolts, washers, nuts
- Grass Chute (for non-mulching mowers) with bolt, nut and spring
- Wheels
- Cotter Pins

The following tools are needed for assembling your new Swisher Riding Mower:

- Safety Glasses
- 1/2" box wrench
- 2 - 7/16" box wrenches
- 7/16" socket and ratchet
- 5/32" hex key wrench

ASSEMBLY

To assemble your new mower, complete ALL of the following steps.

1. INSTALL STEERING WHEEL

- Align the key in the steering wheel hub with the slot in the end of the steering shaft and press down.
- Use a hex key wrench to install and tighten the set screws on the side of the steering hub.
- Insert the 1/4-20 x 1/2" long bolt and washer into the steering hub.
- Tighten the bolt until snug. **Do not over-tighten**
- Install the cap plug to cover the bolt and washer.

1. INSTALLING THE WHEELS

- Insert the axle through the hub of the wheel with the valve stem facing away from the mower. **(Be sure to place the supplied spacers between the surface of the axle weldment and the hub to prevent the tire from rubbing the weldment.)**
- With the wheel in position, insert a cotter pin in the hole on the end of the axle. Use pliers to spread the ends of the cotter pin to retain the wheel in position. Repeat this process for the other side.
Important - Do not forget to spread the ends of the cotter pins to keep wheel assembly in place.

3. CHECKING THE ENGINE

- The engine has been serviced prior to shipment. **However, it is important to check the oil level prior to starting the engine. If more oil is required, follow the engine manufacturer recommendations. Be careful not to overfill.**

4. ADD GASOLINE

- **IMPORTANT! GASOLINE SHOULD BE ADDED OUTSIDE IN A WELL VENTILATED AREA.**

- Add approximately one gallon of fuel to the tank. Be certain to follow the engine manufacturers recommendations on the type of fuel to use.

5. CHECKING GEARBOX LUBRICANT

- The gearbox is filled with lubricant at the factory. However, verify that the gearbox is filled by removing the Oil Check Plug (Part #T143P) located on the side of the gearbox.
- The lubricant should be level with the oil check plug opening.
- If you need to add lubricant, use **ONLY** TR125L, which is specially blended by Swisher Mower and Machine Company.

6. INSTALLING THE SEAT

- The seat should be installed using the two (2) bolts and lock nuts supplied.

- Attach the wiring from the mower to the seat safety switch. **Important! The wiring must be connected to the seat safety switch for the mower to operate.**

- **On 12 volt models:** attach green wires and the brown wires to the two (2) remaining positions on the safety switch.

- **On non-12 volt models:** attach the two (2) brown wires to the safety switch.

- The order of wire attachment or position does not matter.

7. INSTALLING THE GRASS CHUTE (for non-mulching mowers only)

- Attach the grass chute using the bolt, nut and spring supplied. **Important! Do Not operate without the grass chute in place!**

BECOMING FAMILIAR WITH YOUR NEW SWISHER MOWER

Select an open area with no obstructions to complete the following steps which will help you familiarize yourself with the location and movement of the mower controls. The engine SHOULD NOT be running as you familiarize yourself with these controls.

RIGHT AND LEFT SIDES OF MOWER ARE DETERMINED BY SITTING IN THE DRIVER'S SEAT.

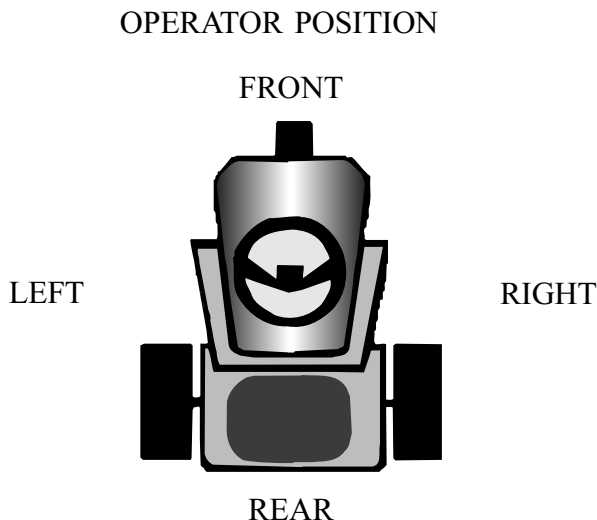

BE SURE TO READ THIS SECTION BEFORE STARTING THE ENGINE FOR THE FIRST TIME

- Check fuel and oil levels.
- Make sure the Drive Control and Blade Clutch Levers are pulled back and disengaged. Make sure your foot is off the pedal.
- Once engine is started, become familiar with the steering and maneuvering of the mower before engaging the blades.

DRIVE ENGAGEMENT PIN:

- The Lock Pin Lever (TR148L) should always be engaged (flat against the wheel) BEFORE starting the engine. **To move the mower when engine is not running, the Lock Pin Lever (TR148L) must be disengaged.**
- **Do not engage pin when engine is running.** The Lock Pin Lever (TR148L), located opposite the

chain on the front wheel, is engaged when it is resting flat against the front wheel.

ENGAGING THE DRIVE: Hand-Operated/Two-speed Drive: (all models begin with AZ2)

- The motion of the mower is controlled by the Drive Clutch Lever (AZ125) located just below the steering wheel, on the left side.
- To engage the drive, start the engine.
- Push the Drive Clutch Lever (AZ125), which is located on the left side of the steering wheel, forward. The mower will BEGIN MOVING FORWARD IN THE DIRECTION THE FRONT TIRE IS POINTED.

- To disengage the drive, pull the Drive Clutch Lever (AZ125) back.
- The lever on the right side of the steering wheel controls ground speed:

Low Speed: place the lever in the lower position closest to the operator. This speed is excellent for trimming and maneuvering in tight places.

High Speed: push the lever forward (away from) the operator. This speed is used for mowing large open areas.

Changing from low speed to high speed or from high speed to low speed can be done without disengaging the drive.

**Foot-Pedal Operated:
(all models begin with AZV)**

- To engage the drive, press your foot against the pedal. The speed of the mower is regulated by the amount of pressure against the foot pedal.
- The mower automatically stops and brakes when you lift your foot off the pedal.
- The abruptness of the stop depends on how quickly you take your foot off the pedal.

ENGAGING THE BLADES:

The Blade Clutch (BR20AZ) is located on the left side below the seat.

- To engage the blades, move the lever toward the front of the mower.
- To disengage the blades, pull the lever toward the rear of the mower.

THE ZERO-TURNING RADIUS

Swisher’s patented front wheel drive steering mechanism provides 360 degrees of maneuverability.

- Reverse directions by simply turning the front wheel in the direction you want to go.
- To reverse directions in tight areas, pull back the Drive Control Lever (AT125) to stop the mower. Then turn the steering wheel 180 degrees (in the opposite direction). Engage the Drive Lever once again.

**QUICK CHANGE MULCHING
MOWER:**

WARNING!

ALWAYS STOP ENGINE AND DISCONNECT SPARK PLUG WIRE BEFORE OPENING OR CLOSING MULCHING CHUTE!

To use as a side-discharge mower:

Twist knob to unlock chute, let chute open and then twist knob to lock chute.

To use as a mulching mower:

Twist knob, push chute closed and twist knob again to lock.

MOWER MAINTENANCE

Make sure your mower is in safe working condition by keeping the following guidelines in mind every time you use your mower.

- Keep mower in good operating condition and keep safety guards, shields and switches in place. **DO NOT** operate mower if any of these devices are missing.
- Check all nuts, bolts and screws for secure fit to keep equipment in safe working condition. Make adjustments as necessary.
- To reduce fire hazards, keep engine free of grass, leaves or excessive grease.
- **DO NOT** operate mower with damaged or missing muffler. **DO NOT** tamper with exhaust system; this may create a fire hazard.
- **DO NOT** operate engine if air cleaner or the cover directly over the carburetor air intake is removed. Removal of these parts could create a fire hazard.
- Disconnect the battery before repairing the mower.
- Before cleaning, making adjustments or repairing mower, **STOP** engine and disconnect the Spark Plug Wire. **ALLOW THE ENGINE TO COOL.**

- To ensure the most even grass cut, keep the tire pressure at 35 *psi* (pounds per square inch).
- Handle gasoline with care. **DO NOT** smoke or use open flame near gasoline. Use only approved gasoline containers. Never fuel or run mower in poorly ventilated area, such as a garage or utility building.

NEVER ADD GASOLINE TO A HOT ENGINE - ALLOW ENGINE TO COOL BEFORE ADDING GASOLINE.

- Always replace fuel tank cap. Be sure to clean up
- any spilled gasoline.

- Do not change the engine governor settings or overspeed the engine; severe injury or damage
- may result.

Never store mower, with gasoline in the tank, inside a building where flames may reach an open flame or spark. Always allow engine to cool before storing.

ADJUSTMENTS AND ROUTINE SERVICING

WARNING - ALWAYS STOP ENGINE AND DISCONNECT SPARK PLUG WIRE AND BATTERY BEFORE MAKING ADJUSTMENTS OR SERVICING MOWER!

CUTTING HEIGHT ADJUSTMENT:

- Turn Height Adjustment Crank (H7N)
Clockwise to raise the blade
Counter-Clockwise to lower the blade.

BLADE SHARPENING:

- Remove Blade Nut (B108) from Blade Shaft (B100).
- Remove blades (B32S and B32L) and the appropriate Blade Spacers (B101, B102 and/or B103). Note the position of the spacers.
- Sharpen the blades.
- When reassembling, make certain that blade spacers are positioned so blade is still under mowing deck.
- Replace the old Blade Nut (B108) with a new one. Make certain the nut and washer are tightened to a minimum of 95 foot pounds.

LUBRICATION:

Wheel Bearings - Lubricate the Rear Wheel Bearings three times a year by putting a few drops of standard 30 weight engine oil on each Wheel Bearing (F157B).

Blade Bearings - These bearings are sealed and do NOT require additional lubrication.

Gear Box - Located on the drive unit. After every twenty hours of operation, check the oil level by using the Oil Check Plug (T143P) located on the front side of the Gear Box. The oil should be level with the Oil Check Plug. Use only SWISHER Gear Oil (TR124L).

Seat Spring Rods (A153) - Lubricate with gun grease or petroleum jelly once a year.

Engine - Refer to your engine manual for engine lubrication care.

BELTS:

Occasionally check belts for wear. A worn belt should be replaced. See REPAIR (page 12) section for instructions.

STORING YOUR MOWER

Preparing your mower for storage in the fall will result in better operation and a longer life in the spring. It will allow you plenty of time to order parts, make the needed repairs and check for proper operation before the equipment is needed again in the spring. Parts may be obtained from your Swisher dealer or you may call our factory at 800-222-8183 to order parts. The following procedures will help you store your mower in a proper manner.

- **Disconnect Spark Plug Wire**
- Drain the fuel.
- Drain the oil and refill the crankcase with clean oil.
- Clean your mower. Brush off matted clippings and caked-on dirt. Use a wire brush to clean the underside of lawn mower. Use a cloth to wipe away debris from the upper deck. If available, use an air compressor to blow thatch and dirt from hard to reach places.
- Tighten all nuts, bolts and screws; replace any that are missing.
- Sharpen blades. If the blades are worn, replace with new ones.
- Check the tires for cuts and proper air pressure. Replace if needed.
- Store mower indoors in a garage, tool shed or barn. If you must store outdoors, cover with plastic or some other protective covering.
- Consult your engine manual for recommended winter storage preparations.

REPAIRS

WARNING - ALWAYS STOP ENGINE AND DISCONNECT BATTERY AND SPARK PLUG WIRE BEFORE MAKING REPAIRS ON MOWER!

REPLACING THE BLADE BELT:

- Remove left and right mower deck belt shields from mower by removing the Acorn Nut (FR154N) found on the upper deck platforms.
- Release tension on the belt by moving the Idler Control Lever (BR120) toward the rear of the mower
- Carefully remove Blade Belt (BA50) from engine and Blade Drive Pulleys, observing the belt path and position. See Belt Routing diagram.
- Install new Blade Belt in same position. (You may find the belt path illustration in this manual helpful when inserting the new belt.) Hint: It is normal for the new belt to fit tighter than the worn belt. Therefore, to make installation easier, always install the new belt over the Blade Pulleys before installing it over the movable Idler Pulley (B527).
- Once installed, the Blade Belt should not slip on pulleys when Idler Control Rod is disengaged.

- If the Belt slips or blades turn, first verify that you are using a genuine Swisher Blade Belt (BA50).
- Check belt for correct positioning around pulleys. If the Belt is still not fitting properly, the Idler Control Rod (B25RAZ) may need to be adjusted by loosening the belt. Tighten the two nuts so that they screw TOWARD the mower.
- Reinstall belt shield and acorn nut and washers after completing installation and adjustments.

REPLACING THE TRACTION DRIVE BELT:

If drive belt slips, makes noise or does not allow travel of the mower, check the following:

- Inspect the condition of the belt and replace if frayed, cracked, excessively worn or damaged.
- Inspect the condition of the Idler Control Spring (682S) on variable speed units or Belt Engage spring (T30S) on two speed units. Replace the spring if needed.

REPLACING THE VARIABLE SPEED BELT:

- Remove steering wheel and throttle control knob.
- Remove hood (AZ154) and recoil shroud.
- Loosen or remove brake (T39CB).
- Replace old belt with genuine Swisher belt (T39).
- Reinstall all parts.
- Check all parts to make sure there is no interference and that unit operates properly.

REPLACING TWO SPEED BELT:

- Remove steering wheel throttle control knob and engagement levers.
- Remove hood (AZ154) and recoil shroud
- Remove gas tank mounting bracket.
- Remove belt cage (AZ32C).
- Remove both two speed belts (T223).
 - Shift to low speed.
 - Lift fingers on Idler Arms (T239V and T239L).
 - Slip belt under Idler Pulley and off of Drive Pulleys.
 - Change to high speed.
 - Slip belt over Idler Pulley and off of Drive Pulleys.
 - Remove Traction Belt (BA50), replace.
- Reassemble all parts in reverse order.
- Check all parts to make sure there is no interference and that unit operates properly.

MULCHING MOWERS

(Models ending in “M”)

To adjust your mower for mulching, make sure your discharge chute is closed so grass clippings cannot escape and may be cut several times. To close the chute, slide the chute TOWARD the mowing deck and tighten the knob.

Your Swisher Mulching Mower has the built-in flexibility to convert into a regular side discharge mower within seconds. When grass has grown too tall for mulching, you should use the side-discharge feature.

Change from Mulching Mower to Side Discharge Feature:

WARNING! ALWAYS REMEMBER TO TURN OFF YOUR ENGINE AND BLADES BEFORE OPENING OR CLOSING THE SIDE CHUTE!

- Open the quick-change chute by unscrewing the knob located on the right side of the mower deck. (The chute is spring loaded and will open gently.)
- After mowing with the chute open, close the chute and make another pass over the grass clippings in order to mulch them into fine clippings.

HINTS FOR EFFECTIVE MULCHING:

The key to effective mulching is to MOW OFTEN. Grass which has grown abnormally long cannot be mulched properly; attempting to mulch grass which is too long will result with the grass clippings clumping and leaving your lawn a mess.

It is important for the health of your lawn to insure you do NOT cut your grass too short. Cutting the grass less than one inch can weaken the grass and increases the possibility of weeds and pests injuring your lawn.

SWEEPER/COLLECTOR MOWERS

(Models ending in “S”)

The Sweeper Mower can provide a manicured finish for your lawn if properly used. To obtain the best results possible, you should consider the height, type and condition of your grass and the speed at which you mow. Remember, the sweeper mechanism is automatically engaged any time the blades are engaged.

MOWING HINTS - As with all collecting systems, your Sweeper will achieve maximum efficiency if you do not allow the grass to grow too high. Mowing regularly will not only enhance the appearance of your lawn, but will reduce the number of times you need to empty the collector.

After the initial mowing with this mower, you may notice areas of grass that appear to be cut unevenly. As grass undergrowth usually grows outward instead of upward, the Sweeper must lift the grass blades before cutting. A second mowing of the uneven areas should help the appearance. Regular mowing with your Sweeper Mower will help prevent undergrowth from reestablishing; this will encourage a thicker and healthier lawn.

STRIPING - You can achieve the same “striping” for your lawn with your Swisher Mower as the professionals do on baseball fields or golf courses. To do this, mow in a back and forth manner - cutting in the opposite direction and directly against the previously mowed path. The brushes sweep the grass of alternate paths in opposite directions.

POSITIONING AND REMOVING

COLLECTOR - When placing the collector on the mower, lift the deflector covering to the rear discharge opening of the mower and place the arms of the collector securely into the respective slots.

The collector is easily removed for storage or for mowing without the collector; simply lift the arms of the collector simultaneously out of the slots. Make certain the deflector shield covers the rear discharge opening of the mower after removing the bag.

EMPTYING THE COLLECTOR - BE SURE TO DIS-ENGAGE BLADES AND STOP ENGINE BEFORE EMPTYING THE COLLECTOR!

To empty the collector, pull the rear support bar of the collector up toward the mower. The pile of clippings or leaves will fall almost directly below the collector.

COMPOSTING

For those interested in composting their yard debris, the easy-empty design of the bag will be of great service. It allows you to gather your clippings in one place without ever having to leave the driver's seat.

MULCHING - If your mower is not equipped with a mulching attachment, you can still use your sweeper to mulch. Simply empty the clippings into a pile, re-cut the pile several times to get the reduced volume desired. The valuable nutrients in these clippings can either be returned to the soil by spreading the clippings onto the lawn; you may also add the clippings to your composter.

BRUSH ADJUSTMENTS

The sweeper brush has been cut at the factory to the most commonly used length. The length of brush, however, may be easily shortened if necessary by following these procedures:

- **Turn the engine off and disconnect the spark plug wire.**
- Then take a sharp pair of scissors and cut the bristles to the desired length. Be sure and cut the same amount off all three brushes, cutting completely across the length of the brush. We recommend not cutting more than 1/2 inch at a time to avoid cutting the bristles too short.
- Check the performance of the Sweeper brush after each 1/2 inch trim

BAG AND BRUSH REPLACEMENT

The bag is subject to deterioration and wear during normal usage. Inspect the bag periodically for tears, holes or weak spots. Replace as needed. Replacement bags and brooms are available from your local Swisher Mower dealer or call the factory at 800-222-8183.

Swisher Zero Turn Rider

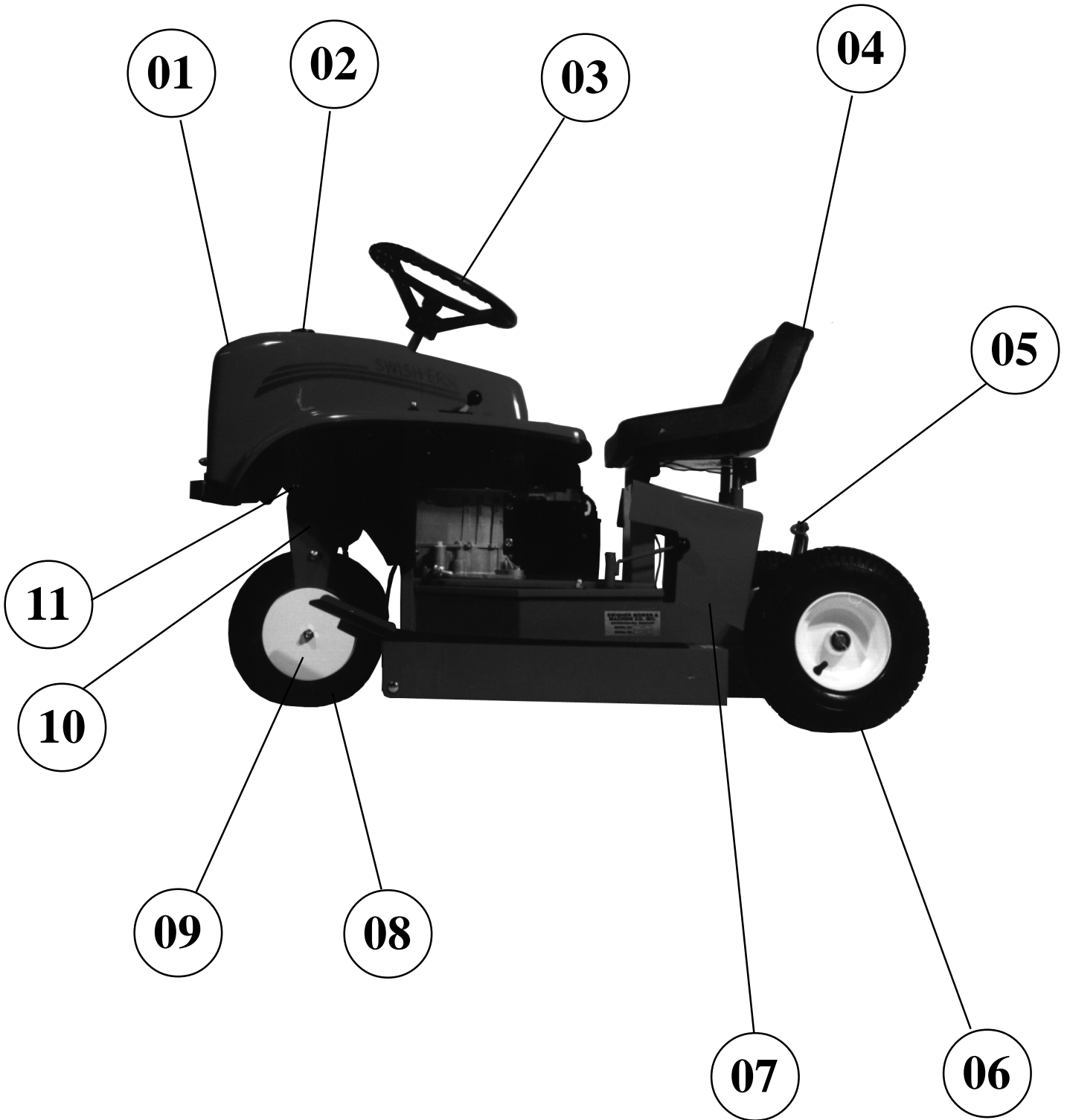

Belt housing with motor base removed

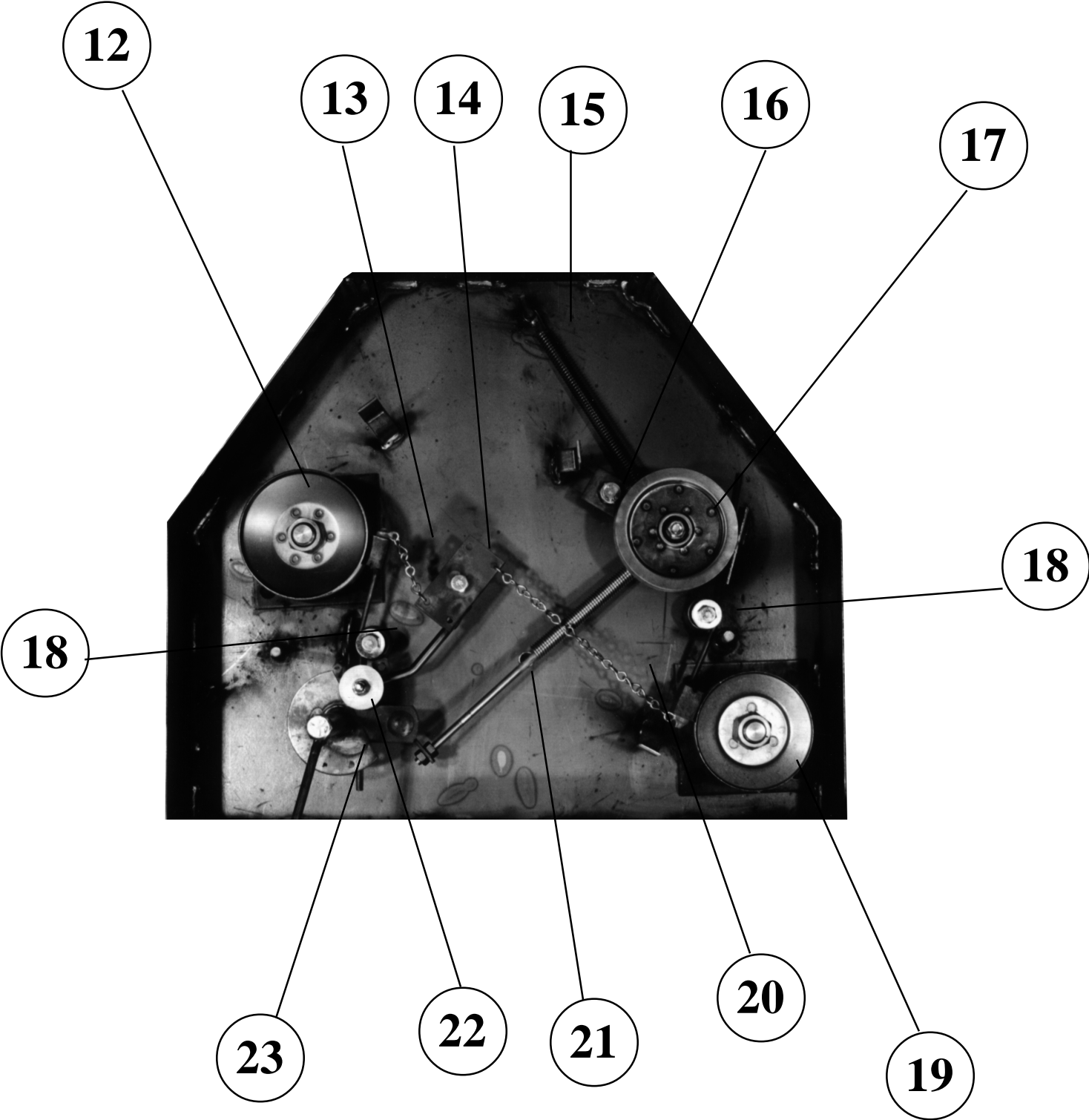

Two speed pulley assembly

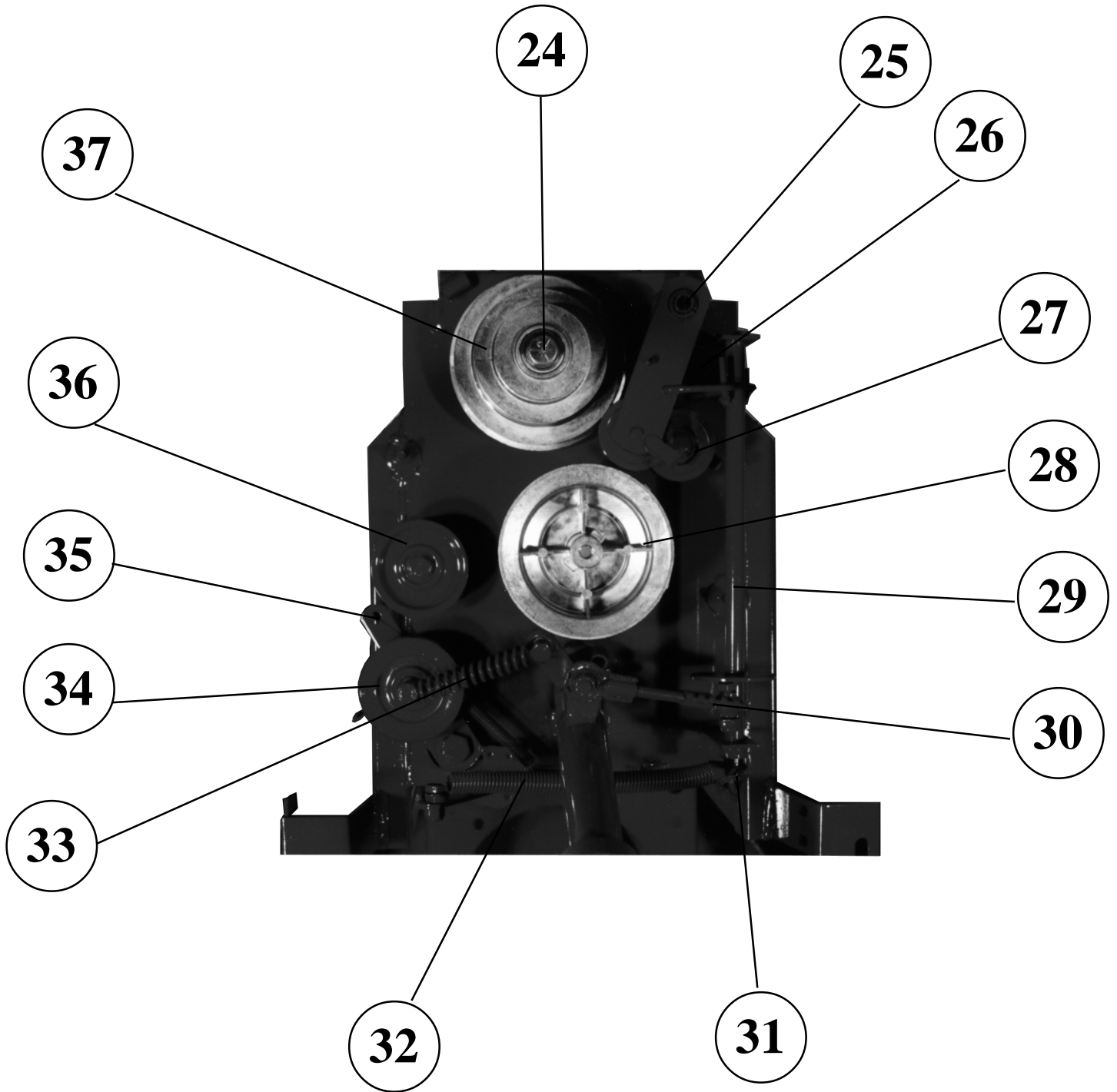

Variable Speed Pulley Assembly

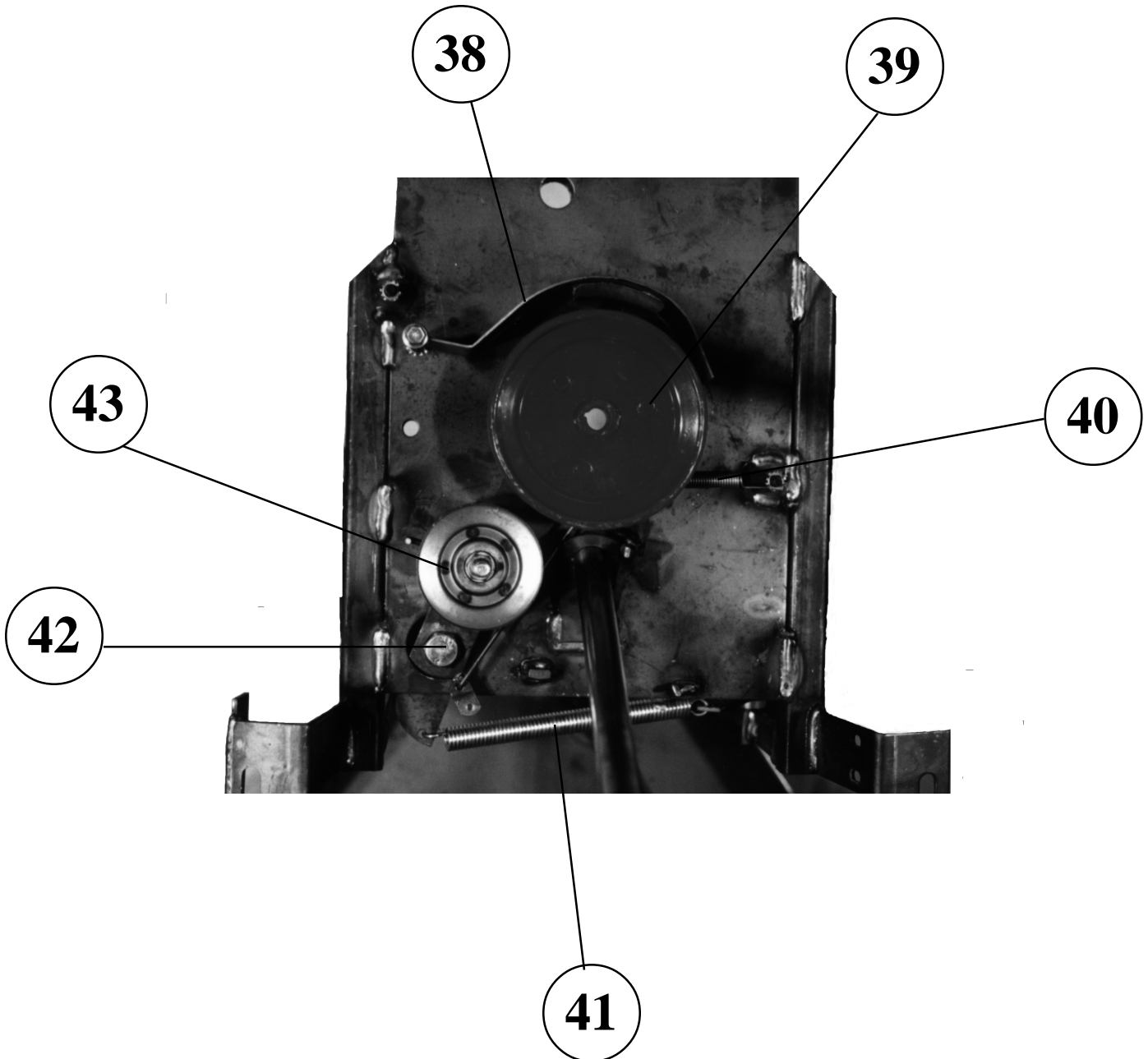

HEIGHT ADJUSTMENT COMPONENTS

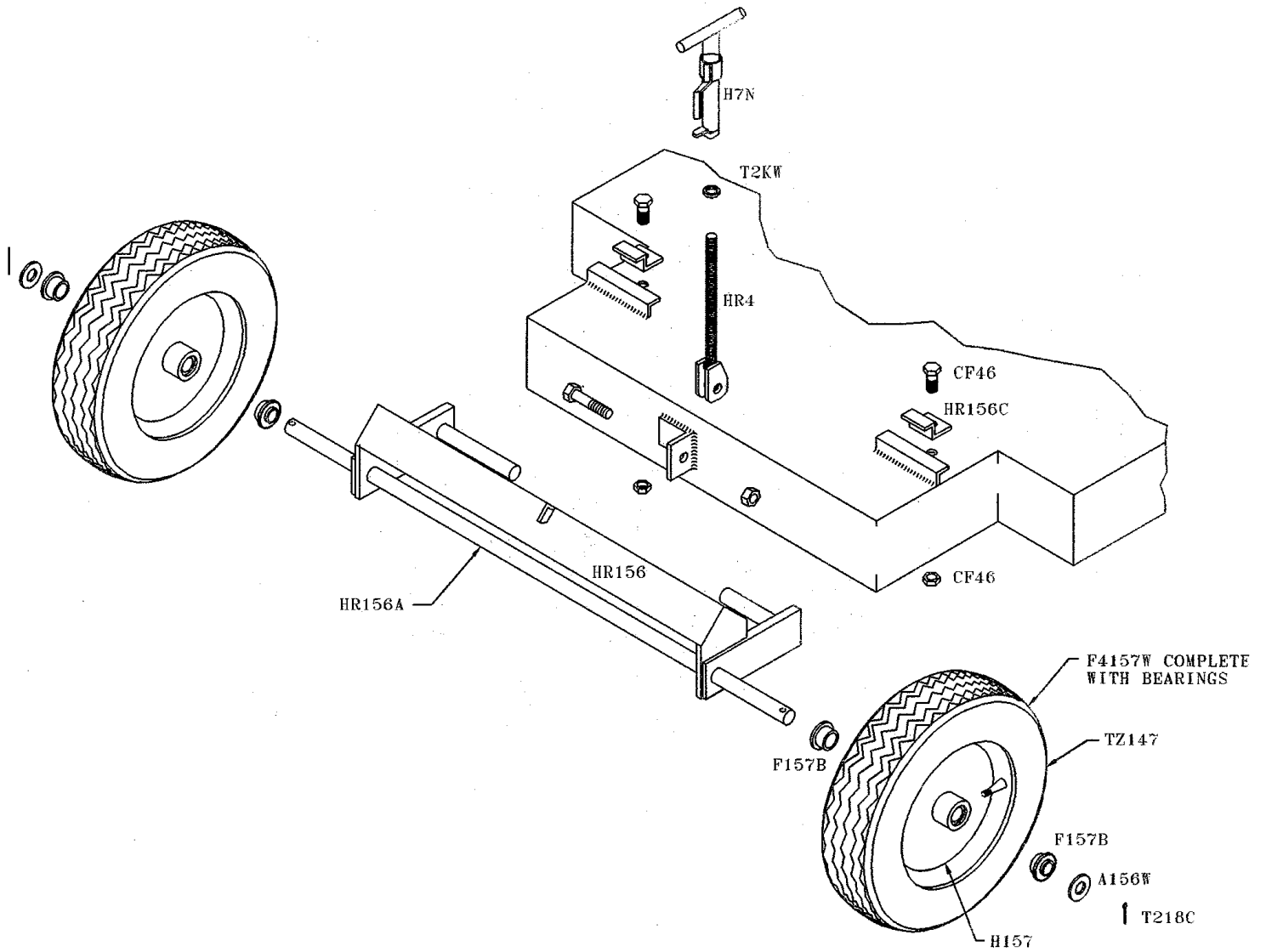

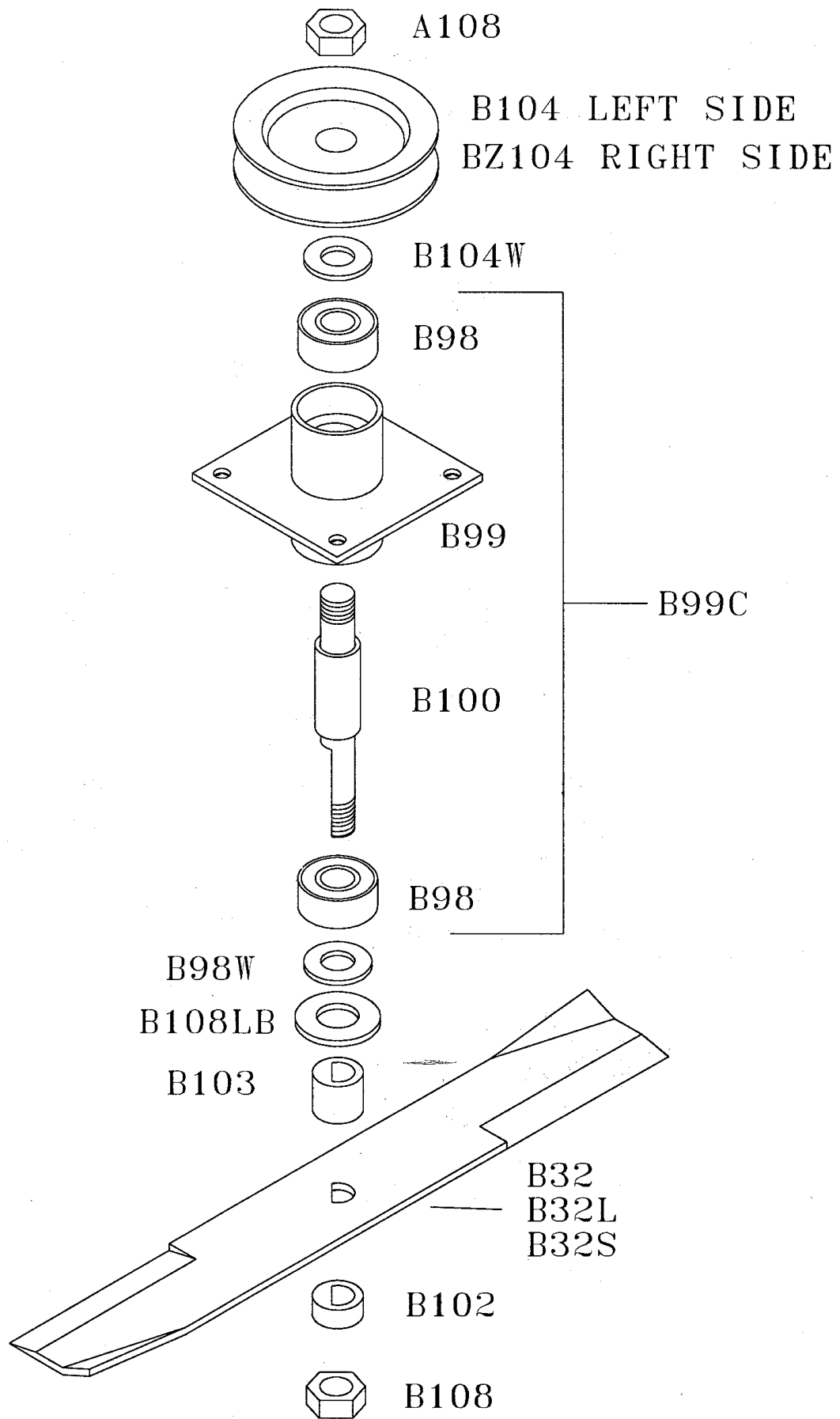

BLADE DRIVE ASSEMBLY

TRACTION ASSEMBLY

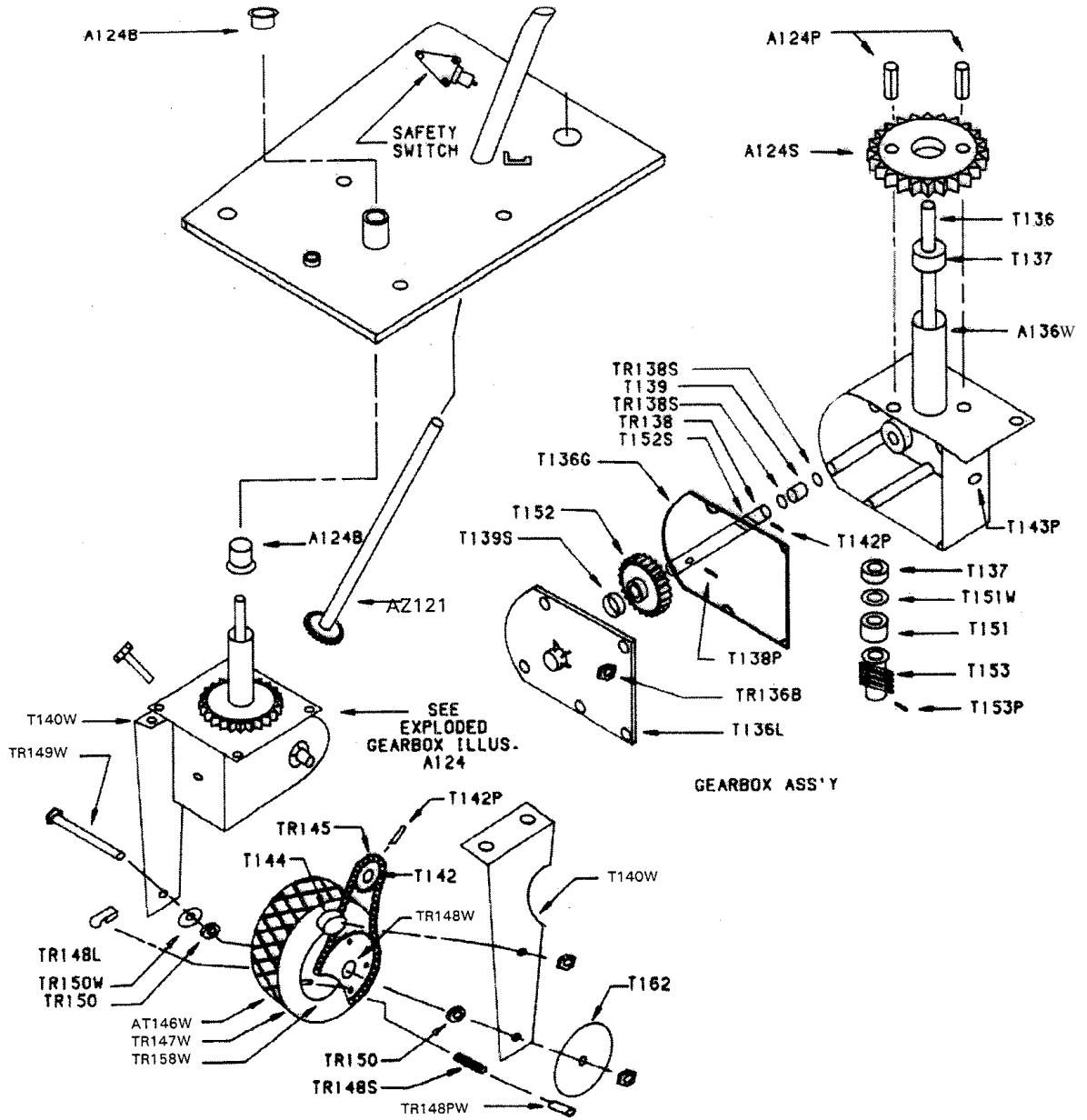

TWO SPEED PULLEY ASSEMBLY

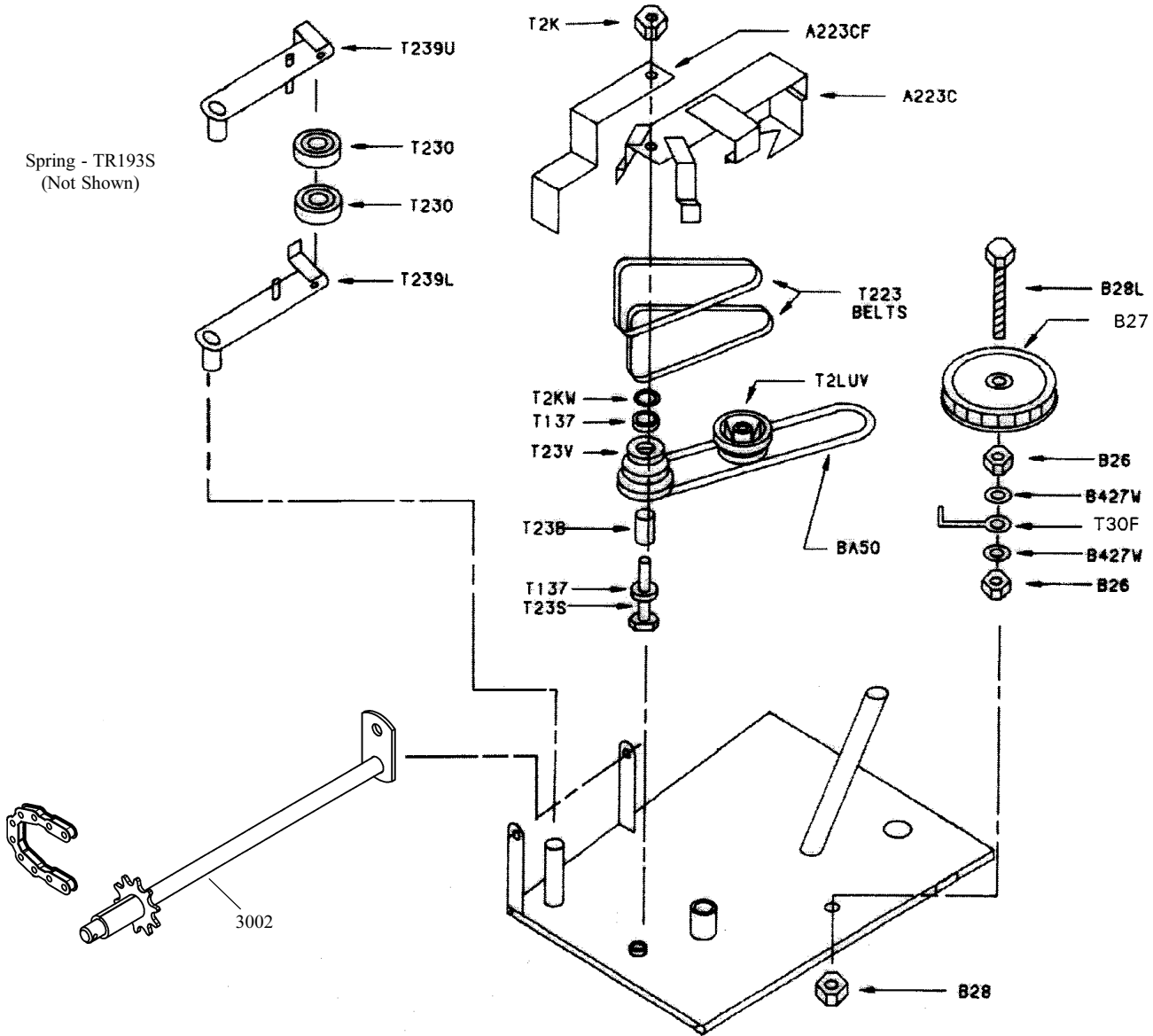

MULCHING MOWER

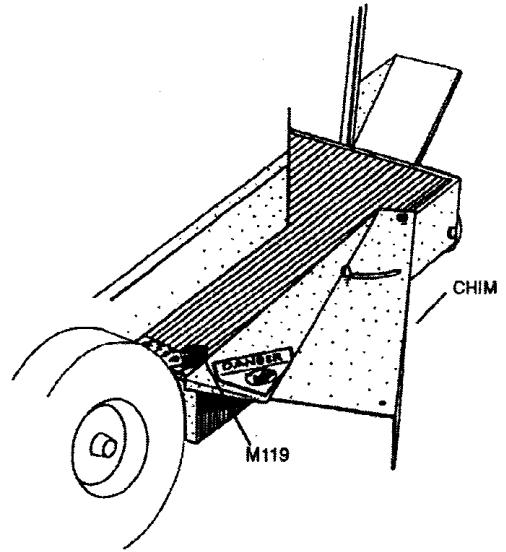
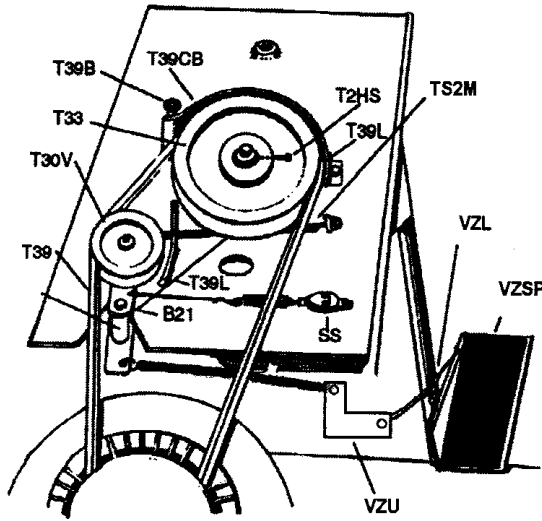

BLADE ASSEMBLY

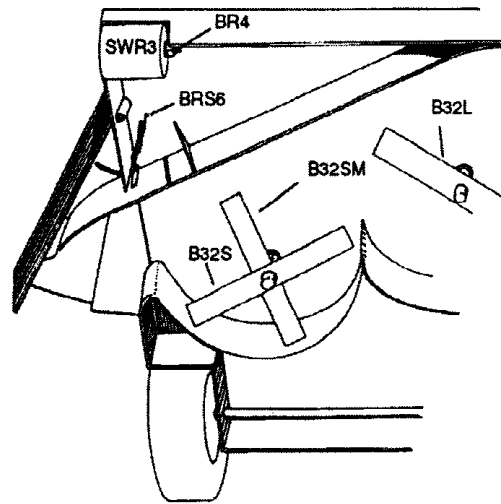
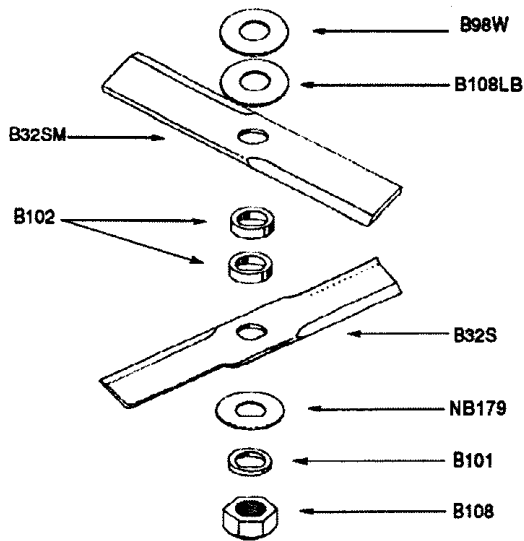

WIRING DIAGRAMS

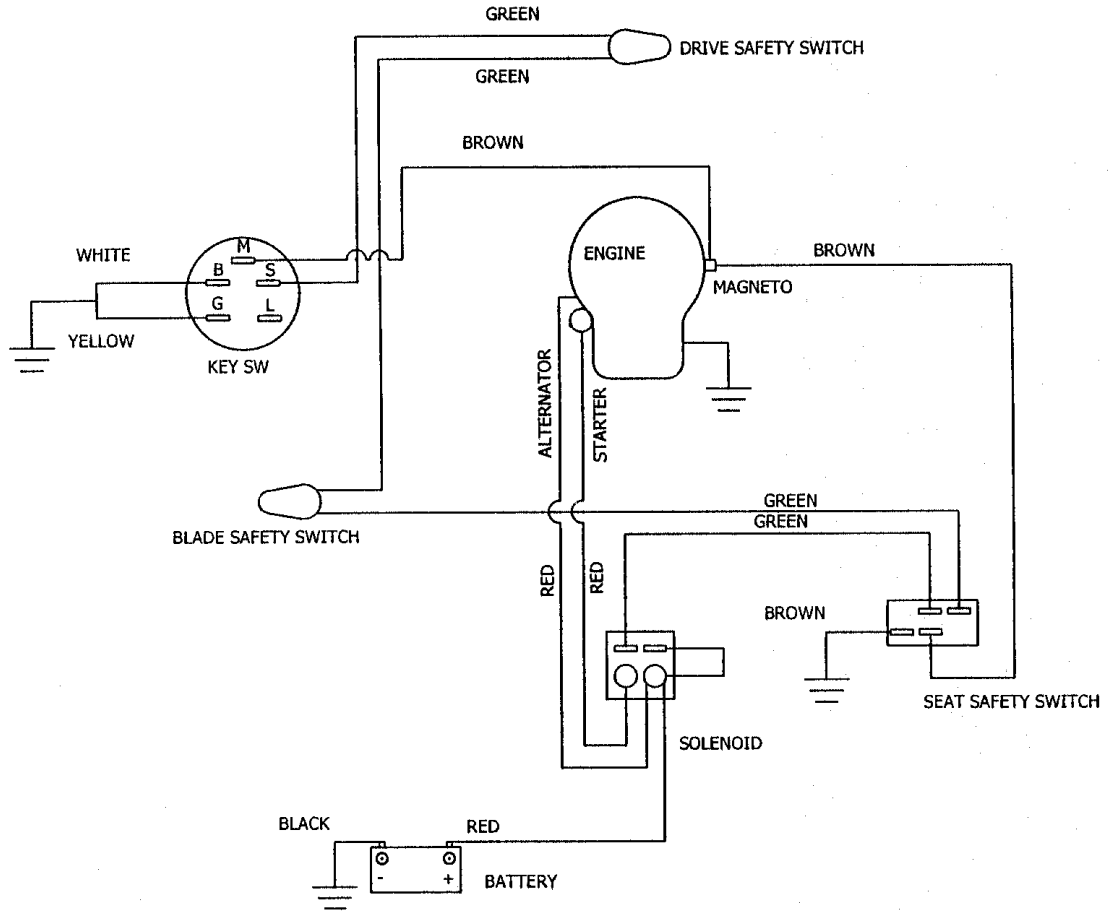

12 VOLT STARTER

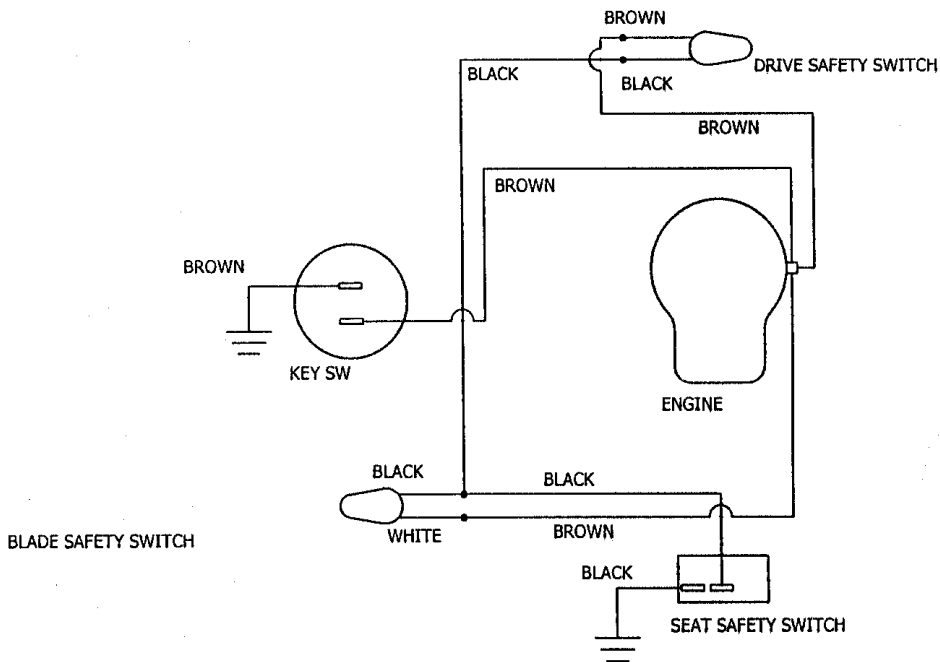

110 VOLT & RECOIL STARTER

Replacement Parts

ITEM#	DESCRIPTION	PART
1	Hood	AZ154
	Grommet - large	AZ154GL
	Grommet - small	AZ154GS
	Hood trim	AS116
	Steering/fuel port trim	AS117
	Mounting bolt	AZ154B
	Acorn nuts	FR154N
2	Gas cap	AZ154C
	Gas tank	AZ154T
	Tank mount	AZ154TM
	Tank straps	AS013
	Fuel line	FLH27
3	Steering wheel	AZ120
	Bushing	AZ120B
	Set screw - short	AZ120SS
	Set screw - long	AZ120SL
	Key stock	AZ120K
	Bolt 1/4 - 20 x 1/2	AZ120BL
	Cap plug	AZ120CP
	Steering shaft/sprocket	AZ121
4	Seat	AZ159
	Seat hinge	AZ159H
	Seat plate	AZ159P
	Bolt/nut - seat	AZ159PB
	Bolt/nut - hinge	AZ159HB
	Seat spring	A153
	Seat safety switch	SS97
5	Height adjust crank	H7N
6	Rear tire/wheel/bearing	F4157W
	Cotter pin	T218C
	Rear axle	HR156A
	Rear axle weldment	HR156

Replacement Parts

ITEM#	DESCRIPTION	PART
7	Lower shroud	AZ154L
	Washer/nut	AZ154LWN
8	Front wheel/tire/bearing	
9	Chain guard	T162
10	Traction Assembly	A124W
	Flanged bushing (upper/lower)	A124B
	Steering gear pin	A124P
	Steering gear	A124S
	Gear case	A136W
	Flathead socket screws	A140
	Worm shaft	T135
	Gasket	T136G
	Gear case lid	T136L
	Bearing	T137
	Gear pin solid	T138P
	Roller bearing	T139
	Retainer ring	T139S
	Wheel bracket	T140W
	Split pin for sprocket	T142P
	Oil plug	T143P
	Chain idler	T144
	Thrust bearing	T151
	Washer	T151W
	Gear	T152
	Gear spacer	T152S
	Worm gear	T153
	Worm pin	T153P
	Gear lube	TR124L
	Bolt/nut	TR136B
	Gear shaft	TR138
	Seal	TR138S
	Kepnut 3/8" x 16	B21N
	Master link 3/8" chain	CL41
	Shoulder bolt	T139B
Sprocket	T142	
Belt release finger	T30F	

Replacement Parts

ITEM#	DESCRIPTION	PART
	Idler control spring	T30S
	Idler spacer	T30SL
	Idler clutch pulley	T30V
	Idler clutch pulley bolt	T31B
	Engine belt	T39
	Top engine pulley	TE32B
	Idler control arm	TR139AZ
	Drive chain	TR145
	Air tire - 5"	TR147W
	Tube for TR147W	TR147TW
	Drive sprocket/hub assembly	TR148W
	Lock pin/lever & rivet	TR148L
	Lock pin - 5" Tire	TR148PW
	Lock pin spring	TR148S
	Front axle bolt/nut	TR149W
	Bearing	TR150
	Washer	TR150W
	Front wheel - 5"	TR158W
11	Fender skirt - right	AZ154FR
	Fender skirt - left	AZ154FL
12	Blade driver assembly - left	see illustration #
13	Left brake chain	BT35
14	Brake lever	BT97AZ
15	Tension spring	BRS6
16	Idler arm	678R
	Bolt/nut	B21
17	Idler pulley	B527
18	Brake pad	BP370
	Brake spring	BT297
	Bolt/nut/washer	BT297B, BT297N, BT297W
19	Blade driver assembly - right	see illustration #
20	Right brake chain	BT315
21	Idler rod/spring	B25RAZ
22	Brake cam bearing	BCB

Replacement Parts

ITEM#	DESCRIPTION	PART
Two Speed only		
23	Blade engage lever assembly	BR20AZ
24	Three step pulley bolt/nut	T23S/T2K
25	Upper idler arm	T239U
	Upper idler arm pulley	T230
26	2 speed hi-lo link	T22L
27	Lower idler arm	T239L
	Lower idler arm pulley	T230
28	Two step pulley	T2LUV
29	Shift rod	T2AZ
30	Shift linkage	T2AZL
31	Tension linkage	TZ2F
32	Tension spring	682S
33	Belt engage spring	T30S
34	Belt drive pulley	T30V
35	Belt drive pulley arm	TR139AZ
36	Idler pulley	B27
37	Three step pulley	T23V
Two Speed items not shown		
	Bearing spacer	T23B
	Belt release cage	A223C
	Belt release finger	A223CF
	Belt, High/Low - 23"	T223
	Bolt/nut for grass chute	CH5B
	Grass chute	CH5
	Grass chute clips	CH5S
	Shift lever	AZ125L
	Shift levers/knobs	AZ125/B19
	Shift tube assembly	AZ125T
Variable Speed only		
38	Variable speed brake	T39CB
39	Drive pulley	T33
40	Spring	T2SM
	Link	T39L
41	Spring	682S
42	Idler arm	V139AZ
43	Idler pulley	T30V

Replacement Parts

ITEM#	DESCRIPTION	PART
Variable Speed items not shown		
	Accelerator lower linkage	VZL
	Accelerator pedal	VZSP
	Accelerator upper linkage	VZU
	Eye bolt for accelerator	VZE
	Mounting bolt/nut for pedal	VZBN
All Models items not shown		
	Air filter (Briggs 8hp)	FF8
	Anti-scalp rollers	SWR3
	Anti-vibration rubber clamp	A155V
	Battery cable - black	BCS
	Battery cable - red	BCSR
	Battery cable (long)	BCL
	Battery cable, small rubber boot	BCBT
	Battery pad	BATPAD
	Battery, 12 volt	BAT
	Bearing, rear wheel	F157B
	Belt cover - left	AZ155L
	Belt cover - right	AZ155R
	Bolt for roller (sweeper)	BR4
	Bolt for Vari-Speed brake	T39B
	Bracket for height adjustment axle	HR156C
	Brake pad	T39BP
	Brake pad retainer spring	BP370S
	Brake spring spacer	BT297S
	Chute Baffle	CHB
	Chute baffle hinge pin	CHBP
	Clutch Rod Spring	P682WS
	Engine bolts & nuts	EBN
	Finger for idler pulley	B427F
	Floor mat	FZ161
	Foot pedal mat	FZ161P
	Fuel line hose clamp	FLHC
	Grommet for belt cover	A155G
	Heat shield	AZHB12
	In line fuel filter	ILFF
	Key switch	KSM
	Key switch - 12 volt	KS12

Replacement Parts

ITEM#	DESCRIPTION	PART
	Keys	KSK
	Knob for mulching chute	M119
	Lower engine pulley (Briggs)	BB105
	Rear axle weldment	HR156
	Safety switch	SS
	Solenoid	SOL NEW
	Spacer for engine pulley	BB105S
	Thick Washer for axle	A156TW
	Throttle cable assembly	THRAZ
	Washer for Axle	A156W
	Washer, hardened steel	T2KW
	Wire link for idler arm	BRS6H

Decals

Arrow Hi-Low	D54
Big Mow	D53
Blade engage/disengage	D10
Caution Hands	D20
Caution No Step	D11
Caution Oil Level	D14
Clutch Lever	D18
Danger Spinning Blade	D29
Key Switch	D28
Made in Missouri	D31
Mulch or Discharge	D27
Ride King	D52
Serial Number	D17
Step Decal	D24
Swisher (hood decal)	D51
Swisher (rear decal)	D50
Warning Serious Injury	D45
Warning Triangle	D55

Replacement Parts

ITEM#	DESCRIPTION	PART
	Blade Assembly	
	Blade spacer 1/4"	B101
	Blade spacer 1/2"	B102
	Blade spacer 1"	B103
	Blade pulley, left	B104
	Washer	B104W
	Blade nut	B108
	Belleville lock washer (2/set)	B108LB
	Blade set	B32
	Blade, 18"	B32L
	Blade set - mulching	B32M
	Blade, 14"	B32S
	Blade, 12" - mulcher	B32SM
	Blade bearing	B98
	Washer	B98W
	Housing for blade & shaft	B99C
	Bolt for B99C	B99CB
	Blade belt	BA50
	Blade pulley, right	BZ104

LIMITED WARRANTY

The manufacturers' warranty to the original consumer purchaser is: This product is free from defects in materials and workmanship, for a period of one (1) year from the date of purchase by the original consumer purchaser. We will repair or replace, at our discretion, parts found to be defective due to materials or workmanship. This warranty is subject to the following limitations and exclusions:

- 1) Engine Warranty All engines utilized on our products have a separate warranty extended to them by the individual engine manufacturer. Any engine service difficulty is the responsibility of the engine manufacturer, and in no way is Swisher Mower Co., Inc. or its agents responsible for the engine warranty. The Briggs & Stratton Engine Service Hot-Line is 1-800-233-3723. The Tecumseh Engine Service Hot-Line is 1-800-558-5402.

- 2) Commercial Use The warranty period for any product used for commercial or rental is limited to ninety (90) days from the date of original purchase.

- 3) Limitations This warranty applies only to products which have been properly assembled, adjusted, and operated in accordance with the instructions contained within this manual. This warranty does not apply to any product of Swisher Mower Co., Inc., that has been subject to alteration, misuse, abuse, improper assembly or installation, shipping damage, or to normal wear of the product.

- 4) Exclusions Excluded from this warranty are normal wear, normal adjustments, and normal maintenance.

In the event you have a claim under this warranty, you must return the product to an authorized service dealer. All transportation charges, and damage and loss incurred during transportation of parts submitted for replacement or repair under this warranty shall be borne by the purchaser. Should you have any questions concerning this warranty, please contact us toll-free 1-800-748-7108.

THIS WARRANTY DOES NOT APPLY TO ANY INCIDENTAL OR CONSEQUENTIAL DAMAGES AND ANY IMPLIED WARRANTIES ARE LIMITED TO THE SAME TIME PERIODS STATED HEREIN FOR ALL EXPRESSED WARRANTIES. Some states do not allow the limitation of consequential damages or limitations on how long an implied warranty may last, so the above limitations or exclusions may not apply to you. This warranty gives you specific legal rights, and you may have other rights, which vary from state-to-state. This is a limited warranty as defined by the Magnuson-Moss Act of 1975.

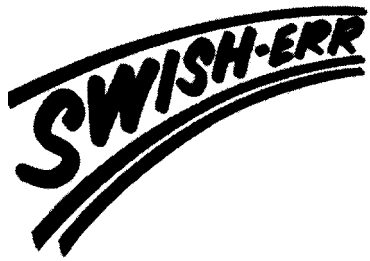

OWNER'S MANUAL

**MODEL NO.
All AZ Series**

Zero Turn Riding Mowers

Each mower has its own model number. Each engine has its own model number. The model number for the mower will be found on the right hand side of the drive belt housing. The model number for the engine will be found on the top of the blower fan housing.

All mower parts listed herein may be ordered directly from Swisher Mower & Machine Co. Inc. or your nearest Swisher dealer.

All engine parts may be ordered from the nearest dealer of the engine supplied with your mower.

WHEN ORDERING PARTS, PLEASE HAVE THE FOLLOWING INFORMATION AVAILABLE.

- * PRODUCT - AZ RIDER
- * SERIAL NUMBER - _____
- * MODEL NUMBER - _____
- * ENGINE MODEL NUMBER - _____
- TYPE - _____
- * PART NUMBER
- * PART DESCRIPTION

TELEPHONE - 1-800-222-8183

FAX - 1-660-747-8650

SWISHER MOWER & MACHINE CO. INC.

P.O. BOX 67

WARRENSBURG, MO 64093

SWISHER MOWER & MACHINE CO. INC.

PRINTED IN U.S.A.