



OWNER'S MANUAL

MODEL NO.
T1260
T1360



Rev.10.06.1997

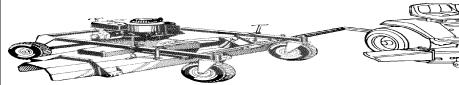

60" UNIVERSAL TRAILMOWER

Assembly
Operation
Service and Adjustment
Repair Parts

P.O. BOX 67, WARRENSBURG, MISSOURI 64093 PHONE 816-747-8183 FAX 816-747-8650

Manufacturing quality lawn care equipment since 1945

Made In The

USA

LIMITED WARRANTY

The manufacturer's warranty to the original consumer purchaser is: This product is free from defects in materials and workmanship for a period of one (1) year from the date of purchase by the original consumer purchaser. We will repair or replace, at our discretion, parts found to be defective due to materials or workmanship. This warranty is subject to the following limitations and exclusions:

- 1) Engine Warranty All engines utilized on our products have a separate warranty extended to them by the individual engine manufacturer. Any engine service difficulty is the responsibility of the engine manufacturer and in no way is Swisher Mower Co., Inc. or its agents responsible for the engine warranty. The Briggs & Stratton Engine Service Hot-Line is 1-800-233-3723. The Tecumseh Engine Service Hot-Line is 1-800-558-5402.

- 2) Commercial Use The warranty period for any product used for commercial or rental is limited to ninety (90) days from the date of original purchase.

- 3) Limitations This warranty applies only to products which have been properly assembled, adjusted, and operated in accordance with the instructions contained within this manual. This warranty does not apply to any product of Swisher Mower Co., Inc., that has been subject to alteration, misuse, abuse, improper assembly or installation, shipping damage, or to normal wear of the product.

- 4) Exclusions Excluded from this warranty are normal wear, normal adjustments, and normal maintenance.

In the event you have a claim under this warranty, you must return the product to an authorized service dealer. All transportation charges, damage, or loss incurred during transportation of parts submitted for replacement or repair under this warranty shall be borne by the purchaser. Should you have any questions concerning this warranty, please contact us toll -free at 1-800-222-8183. The model number, serial number, date of purchase, and the name of the authorized Swisher dealer from whom you purchased the mower will be needed before any warranty claim can be processed.

THIS WARRANTY DOES NOT APPLY TO ANY INCIDENTAL OR CONSEQUENTIAL DAMAGES AND ANY IMPLIED WARRANTIES ARE LIMITED TO THE SAME TIME PERIODS STATED HEREIN FOR ALL EXPRESSED WARRANTIES. Some states do not allow the limitation of consequential damages or limitations on how long an implied warranty may last, so the above limitations or exclusions may not apply to you. This warranty gives you specific legal rights and you may have other rights, which vary from state -to-state. This is a limited warranty as defined by the Magnuson-Moss Act of 1975.

Safety Rules

Safe Operation Practices for Trailmowers

Important: This cutting machine is capable of amputating hands and feet, and throwing objects. Failure to observe safety instructions could result in serious injury or death.

I. General Operation

- Read, understand, and follow all instructions in the manual and on the machine before starting.
- Read this operator's manual carefully. Become familiar with the controls and know how to operate your mower properly.
- Only allow responsible adults, who are familiar with the instructions, to operate the machine.
- Clear the area of objects such as rocks, toys, wire, etc. which could be picked up and thrown by the blade.
- Be sure the area is clear of other people before mowing. Stop machine if anyone enters the area.
- Never carry passengers.
- Do not mow in reverse unless absolutely necessary. Always look down and behind before and while backing.
- Be aware of the mower discharge direction and do not point it at anyone. Do not operate mower without the guards in place.
- Slow down before turning.
- Never leave a running machine unattended. Always turn off blades and stop engine.
- Turn off blades when not mowing.
- Mow only in daylight or good artificial light.
- Do not operate the machine under the influence of alcohol or drugs.
- Watch for traffic when operating near or crossing roadways.
- Use extra care when loading or unloading the machine into a trailer or truck.
- Do not attempt to operate the tow vehicle when not in the driver's seat
- Disengage power to mower, stop engine when transporting or not in use.

- Exercise special care when mowing around fixed objects in order to prevent the blades from striking them. Never deliberately run mower onto or over any foreign object.
- Use mower only as the manufacturer intended and as described in the manual.
- Do not operate the mower if it has been dropped or damaged in any manner. Always have damage repaired before using your mower.
- Always wear safety glasses or eye shields when starting and while using your mower.
- Dress properly. Do not operate mower when barefoot or wearing open sandals. Wear only solid shoes with good traction when mowing.
- Always make cutting height adjustments before starting your mower. Never attempt to do this while the engine is running.
- Keep your eyes and mind on your mower and the area being cut.
- Do not let other interests distract you.
- Do not put hands or feet near or under rotating parts. Keep clear of the discharge opening at all times.
- Before cleaning, inspecting, or repairing your mower, stop the engine and make absolutely sure the blade and all moving parts have stopped. Then disconnect the spark plug wire and keep it away from the spark plug to prevent accidental starting.
- Do not operate your mower if it vibrates abnormally. Excessive vibration is an indication of damage: stop the engine, safely check for the cause of vibration and repair as required.
- Never operate your mower without proper guards, plates, or other safety devices in place.

II. Slope Operation

Slopes are a major factor related to loss-of-control and tip over accidents, which can result in severe injury or death. All slopes require extra caution. If you feel uneasy on it, do not mow it.

DO:

- Mow up and down slopes.
- Remove obstacles such as rocks, tree limbs, etc.

- Watch for holes, ruts or bumps. Uneven terrain could overturn the machine. Tall grass can hide obstacles.
- Use slow speed. Choose a low gear so that you will not have to stop or shift while on the slope.
- Keep all movement on the slopes slow and gradual. Do not make sudden changes in speed or direction.
- Avoid starting or stopping on a slope. If tires lose traction, disengage the blades and proceed slowly straight down the slope.

DO NOT:

- Do not turn on slopes unless necessary, and the turn slowly and gradually downhill if possible.
- Do not mow near drop-offs, ditches or embankments. The mower could suddenly turn over if a wheel is over the edge of a cliff or ditch, or if an edge caves in.
- Do not mow on wet grass. Reduced traction could cause sliding.

III. Children



Caution:
Tragic accidents can occur if the operator is not alert to the presence of children. Children are attracted to the machine and the mowing activity. *Never assume that children will remain where you last saw them.*

- Keep children out of the mowing area and under the watchful care of another responsible adult.
- Be alert and turn machine off if children enter the area.
- Before and when backing, look behind and down for small children.
- Never carry children. They may fall off and be seriously injured or interfere with safe machine operation.
- Never allow children to operate the machine.
- Use extra card when approaching blind corners, shrubs, trees or other objects that may obscure vision.

IV. Service

- Use extra care handling gasoline and other fuels. They are flammable and vapors are explosive.
 - Use only an approved container.
 - Never remove gas cap or add fuel with the engine running.
 - Allow engine to cool before refueling. Do not smoke.
 - Never refuel the machine indoors.
 - Never store the machine or fuel container where there is an open flame, such as a gas water heater.
- Never run a machine inside a closed area.
- Keep nuts and bolts, especially blade attachment nuts, tight and keep equipment in good condition.
- Never tamper with safety devices. Check their proper operation regularly.
- Keep machine free of grass, leaves, or other debris build-up. Clean oil or fuel spillage. Allow machine to cool before storing.
- Stop and inspect the equipment if you strike an object. Repair if necessary before restarting.
- Mower blades are sharp and can cut. Wrap the blade(s) or wear gloves, and use extra caution when servicing them.



Look for this symbol to point out important safety precautions. It means **CAUTION!!! BECOME ALERT!!! YOUR SAFETY IS INVOLVED!!!**



Caution:
Always disconnect spark plug wire and place it where it cannot contact the spark plug in order to prevent accidental starting when setting up, transporting, adjusting or making repairs.

SAFETY AND OPERATIONAL DECALS

Replace decal immediately if damaged. Order by part number from Swisher Mower and Machine Co. Inc.

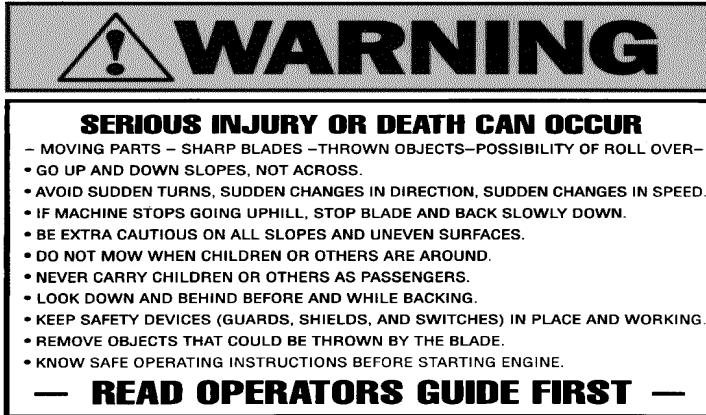

42 Warning Decal



43 Danger Decal

SAFETY AND OPERATIONAL DECALS



CAUTION

THIS DEFLECTOR MUST BE IN PLACE BEFORE OPERATING MOWER.
KEEP ALL SHIELDS IN PLACE.

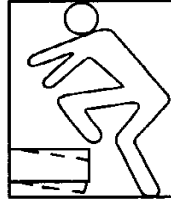

Operating Your New Mower



The operation of any mower can result in foreign objects being thrown into the eyes, which can result in severe eye damage. Always wear safety glasses or eye shields before starting your mower and while mowing. We recommend wide vision safety mask for over the spectacles or standard safety glasses.



Caution:

Tragic accidents can occur if the operator is not alert to the presence of children. Children are attracted to the machine and the mowing activity. *Never assume that children will remain where you last saw them.*

Stopping

- Move blade clutch lever to disengage position.
- Turn key switch to the OFF position.

Attaching Mower to Tow Vehicle

- Place mower behind tractor and back tractor up to it for attaching.
- Slide tow bar of mower over tractor drawbar so that holes line up.
- Insert hitch pin until it extends through the bottom of the tow bar.
- Place safety latch over end of the hitch pin. The red tether is used to **manually disengage** the blades in normal operation, and **automatic disengage** the blades if the tow vehicle becomes separated from the Trailmower.
- A black tether is used to manually engage the blades of the Trailmower without leaving the operator position.
- **It is important that you securely attach both the blade engage and disengage tether to the tow vehicle.**



Caution:

Never operate this mower without both safety tethers securely attached to the tow vehicle.

Transporting Your Mower

- Disengage blades.
- Shut off mower engine.
- Place mower deck in the highest cutting position.

Starting to Mow

- Adjust mower cutting height.
- Start mower engine.
- Move throttle to RUN position.
- Move mower blade clutch lever to the engaged position to start mower blades.



Caution:

Never operate the mower without both discharge chute cover in place.

Mower Height Adjustment



Caution:

Shut off mower and remove spark plug wire before making any adjustments to the mower.

- The mowing height range is approximately 1-1/2 to 4-1/2 inches. The heights are measured from the ground to the blade tip with the engine **not** running.
- The average lawn should be cut to approximately 2-1/2 inches during the cool season and to over 3 inches during hot months. For healthier and better-looking lawns, mow often and after moderate growth.
- For best cutting performance, grass over 5 inches in height should be mowed twice. Make the first cut relatively high, the second to desired height.

**Caution:**

Shut off mower and remove spark plug wire before making any adjustments to the mower.

**Caution:**

Shut off mower and remove spark plug wire before making any adjustments to the mower.

Cutting Height Adjustments

- Rotate height adjust crank handles (item #8 and #5 in fig. 4) in a clockwise direction to raise the mower and in a counter-clockwise direction to lower.
- Make sure that height adjustment is the same on both sides of the mower, as indicated by the graduated scales on the height adjustment tubes.
- **NOTE: Graduated scales are for reference only.**

Front to Back Adjustment

To obtain the best cutting results, the mower housing should be adjusted so that the front is approximately 1/2" to 3/4" lower than the rear. To check for front to back adjustment, measure from the bottom edge of the deck to the ground at both the front and rear of the deck.

Tow Hitch Offset Assembly

This Trailmower has been designed to run offset from the center of the tow vehicle to provide additional cutting width. (Refer to fig. 2 for assembly information)

- The adjustable tow hitch of this mower can be assembled in several positions from straight to 58" offset to either side.
- We recommend when towing with a tow vehicle equipped with a mid mount mower to offset the Trailmower to overlap the cut of the mid mount mower by 6". This will need to be adjusted depending on the type of terrain, obstacles, and the tow vehicle being used.
- If your tow vehicle is not equipped with a mid mount mower the hitch can be adjusted to a straight position, but we recommend using the offset position to eliminate grass being crushed by the tow vehicle.

Tow Hitch Offset Assembly

- Please refer to figure 2 for the assembly of the hitch bar.

Before Starting Engine

- Fill engine with oil. (See engine manual for proper procedure and requirements.)
- Add gasoline. Fill tank using fresh clean unleaded gasoline.

**Caution:**

Fill to bottom of fuel tank filler neck. Do not overfill; wipe off spilled oil or fuel. Do not store, spill or use gasoline near open flame

To Start Engine

**Caution:**

Keep the blade clutch lever in "Disengaged" position when starting engine

- Make sure spark plug wire is properly connected.
- Place throttle control in "Choke" position if the engine is cold. A warm engine may not require choking to start.
- Turn key to start position. Release key immediately when engine starts.
- When engine starts, move throttle control to the "Run" position. (Full throttle)
- Allow engine to warm up for a few minutes before engaging blades.

NOTE: If at high altitude (above 3000 ft) or in cold temperatures (below 32° F), the carburetor fuel mixture may need to be adjusted for best performance. (See service and adjustments section of engine manual.)

Breaking in Your Mower

Break in your belts, pulleys, and engine before you actually begin mowing.

- Start engine, engage blade control to start blades rotating and allow blades to rotate for approximately five minutes to break in mower and engine.



Caution:

Shut off mower and remove spark plug wire before making any adjustments to the mower.



Caution:

Shut off mower and remove spark plug wire before making any adjustments to the mower.



Caution:

Shut off mower and remove spark plug wire before making any adjustments to the mower.

Suggested Mowing Practices

- Mowing should be started with tractor in low gear and speed increased only as mowing conditions will safely permit. This speed should not exceed 3-1/2 MPH.
- Better mowing results will be obtained in grassy areas if they are mowed when the grass is approximately 4-5" maximum height. While your mower will cut grass taller than 5", you will experience a substantial increase in the horsepower required and some change in finished appearance of the area mowed.
- Mowing conditions will vary from place to place, including the types of grass that are being mowed, such as fine stalk, coarse stalk, dense or sparse grasses. When mowing tall grass, you may find that the pressure of wheel tracks may cause certain grasses to be pushed downward and will not be mowed properly. If this condition exists, you may have to mow the area twice, the first mowing with the mower raised and the second at the normal height you have chosen. If it is practical, better results will be found if the second mowing is at a right angle in travel to the previous mowing.
- Do not mow grass when it is wet. Wet grass will accumulate under the mower deck and leave undesirable clumps. Allow grass to dry before mowing.
- Always operate mower at full throttle when mowing to assure better mowing performance and proper discharge of material. Regulate ground speed by selecting a low enough gear to give the mower cutting performance as well as the quality of cut desired.

Mower Maintenance

General Recommendations

The warranty on this Trailmower does not cover items that have been subjected to operator abuse or negligence. To receive full value from the warranty, operator must maintain unit as instructed in this manual.

Some adjustments will need to be made periodically to properly maintain your unit.

All adjustments in the service and adjustments section of this manual should be checked at least once each season.

Before Each Season

- Replace the spark plug.
- Clean or replace the air filter.
- Check blades and belts for wear.

A new spark plug and clean air filter assure proper air-fuel mixture and help your engine run better and last longer.

Before Each Use

- Check engine oil level. (Do this twice to ensure an accurate reading.)
- Check blade operation.
- Check for loose fasteners.

Daily Maintenance

Make sure all nuts and bolts are tight, cotter pins and retainer clips are secure. Keep blades sharp. Observe all safety precautions.

Blade Care and Service

For best results, mower blades must be kept sharp. The blades can be sharpened with a few strokes of a file or on a grinding wheel. Do not attempt to sharpen while on mower.

- To remove blade for sharpening, use wooden block to hold blade while removing the blade-mounting nut. The nuts have right hand threads.
- When grinding, care should be taken to maintain blade balance and the blade should be checked for proper balance before reinstalling on mower.
- Check and balance. File material off heavier end of blade until it is balanced.

To ensure satisfactory operation, it is recommended that before the start of each mowing season, the old blades be discarded and replaced with new blades.

NOTE: Check nuts and blades occasionally to make sure nuts are tight.



Caution:

Shut off mower and remove spark plug wire before making any adjustments to the mower.

Cleaning the Mower

Water pressure from a garden hose will remove fresh clippings from the underside of the mower. Clean mower after each use.

Repair Parts

Your Trailmower has been produced with components designed for your unit. Although standard V-belts, bearings, blades, pulleys, etc. may look like parts used on your rotary mower, and while similar in appearance, many are of a different construction and could in some cases cause a malfunction in the operation of the machine.

For continued satisfactory performance, use only repair parts supplied by the manufacturer. See your SWISHER dealer for replacement parts.



Caution:

Do not handle mower blades with bare hands. Careless or improper handling may result in serious injury.

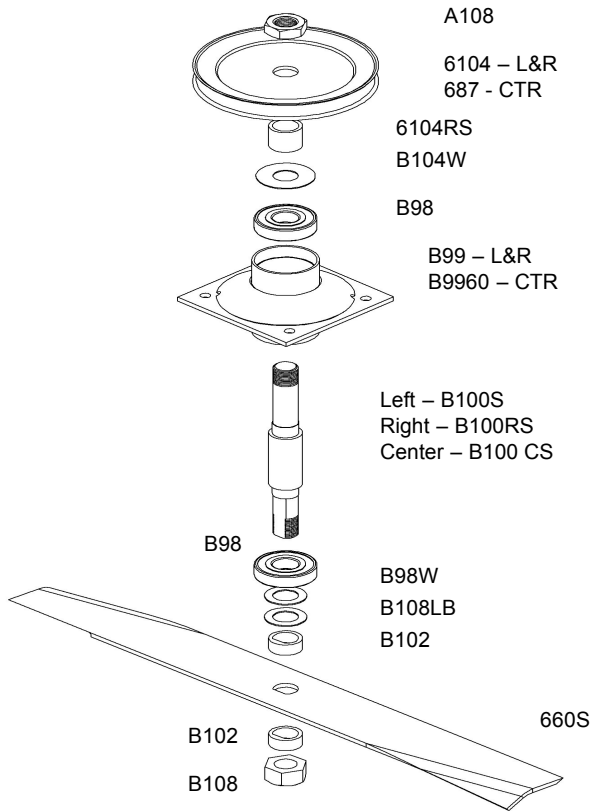

Blade Drive Assembly
Figure 1

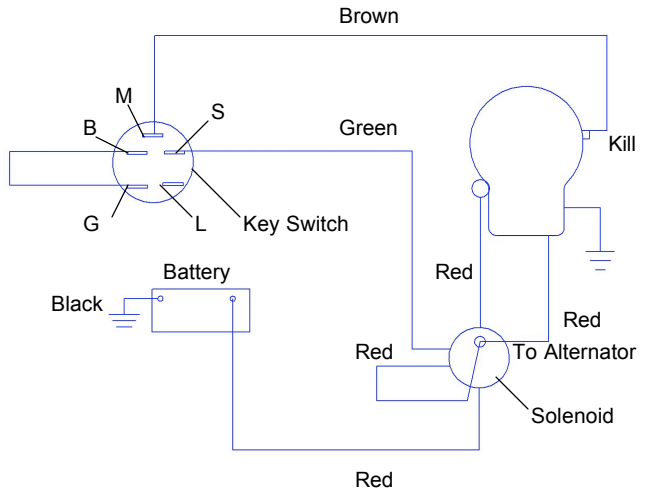

T60 12V Start
Figure 3

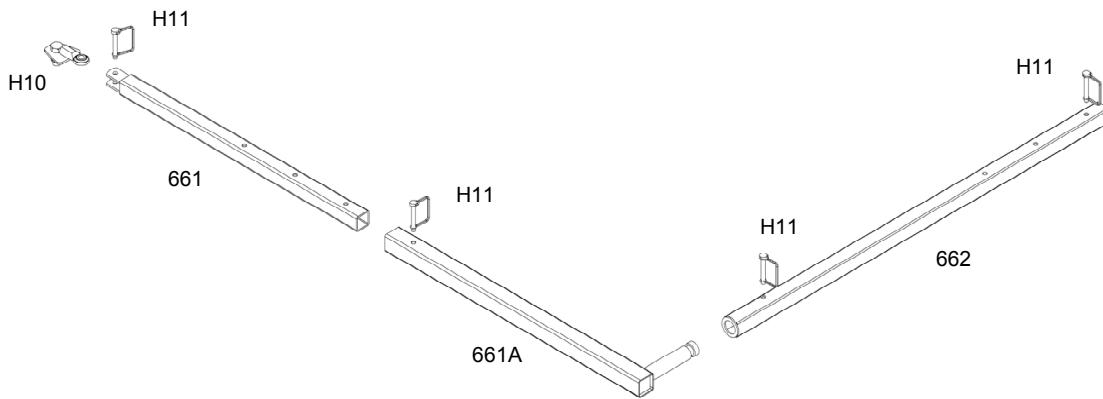

Hitch Bar Assembly
Figure 2

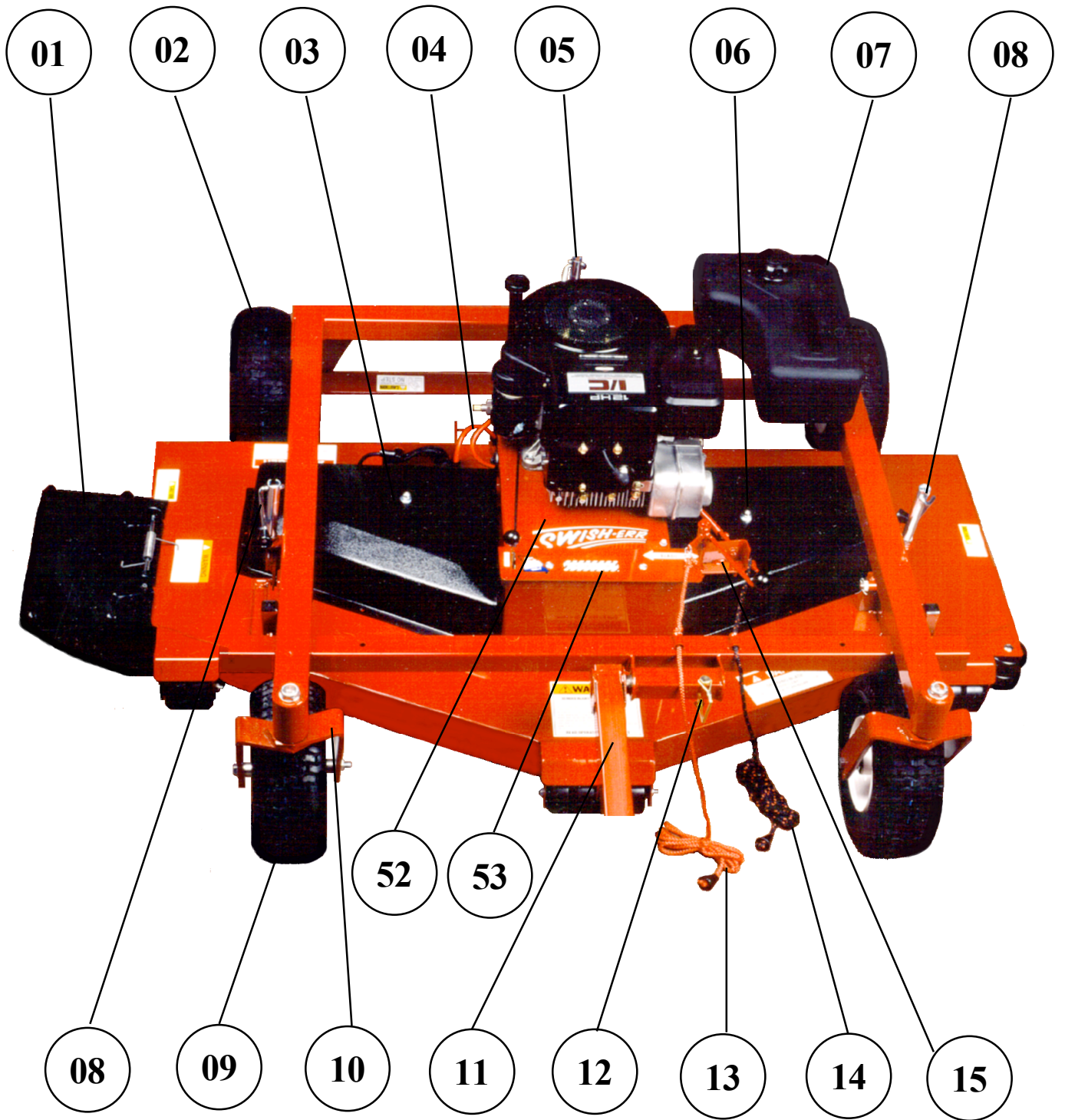

Figure 4
12

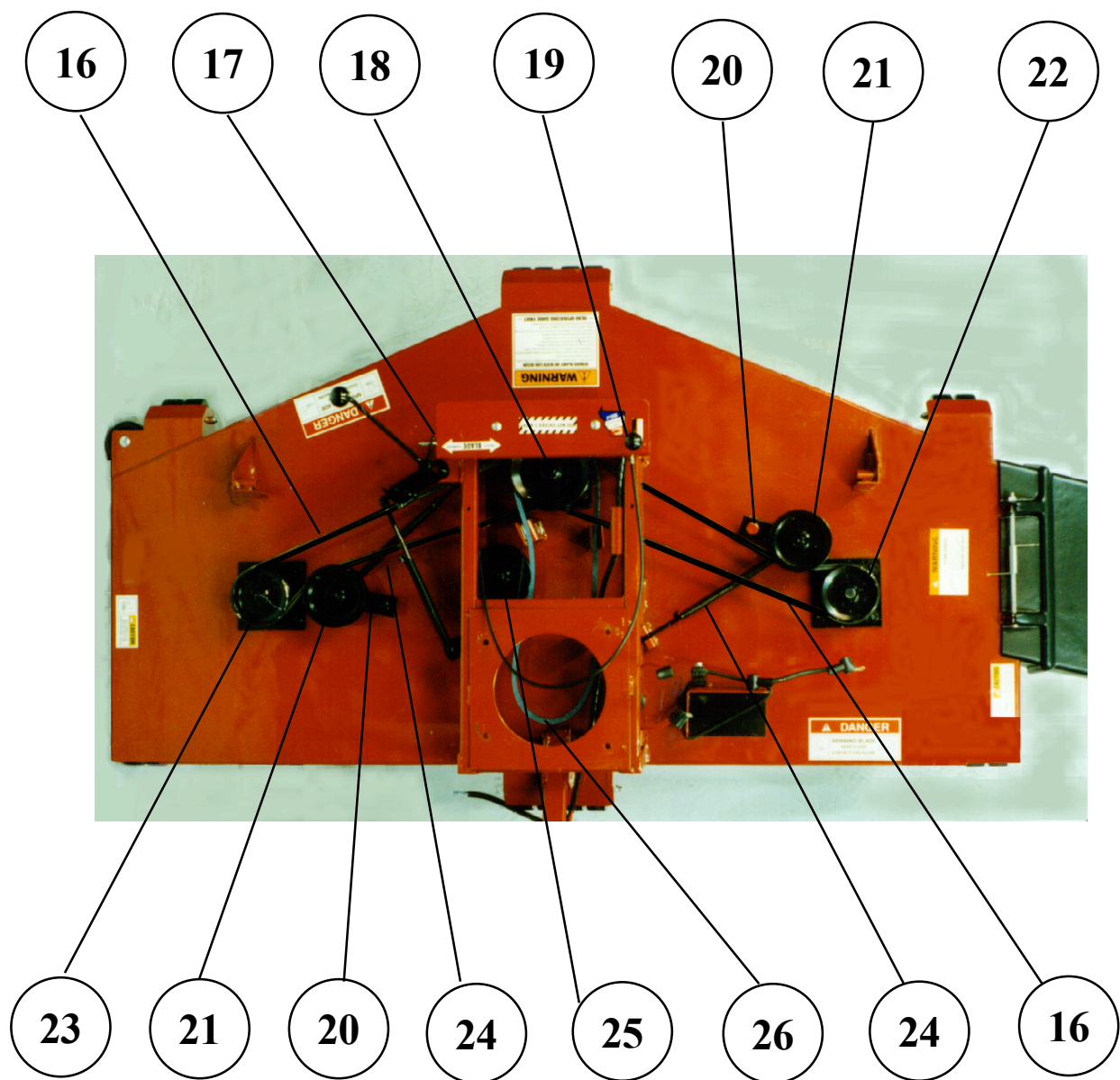

Figure 5

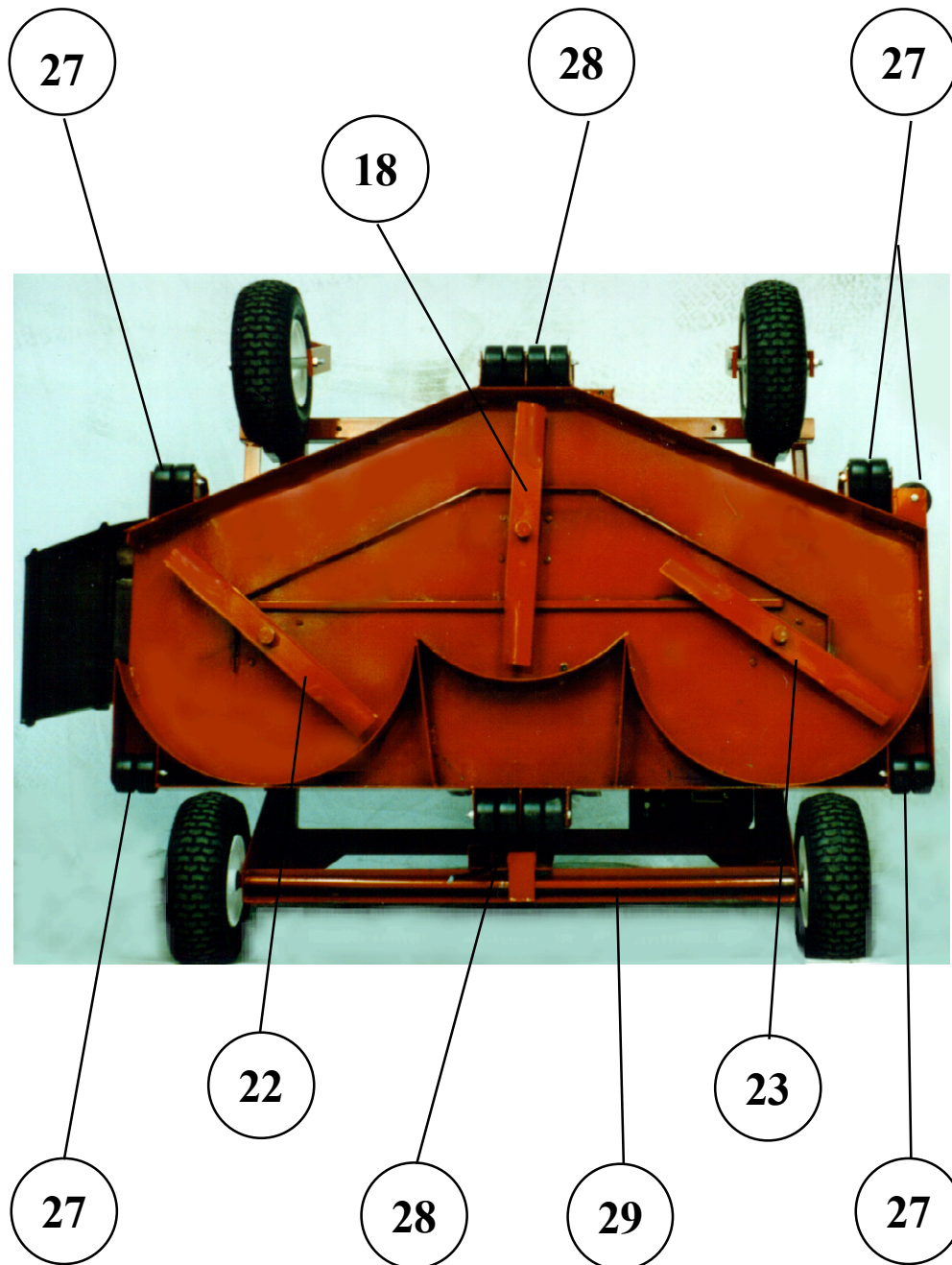
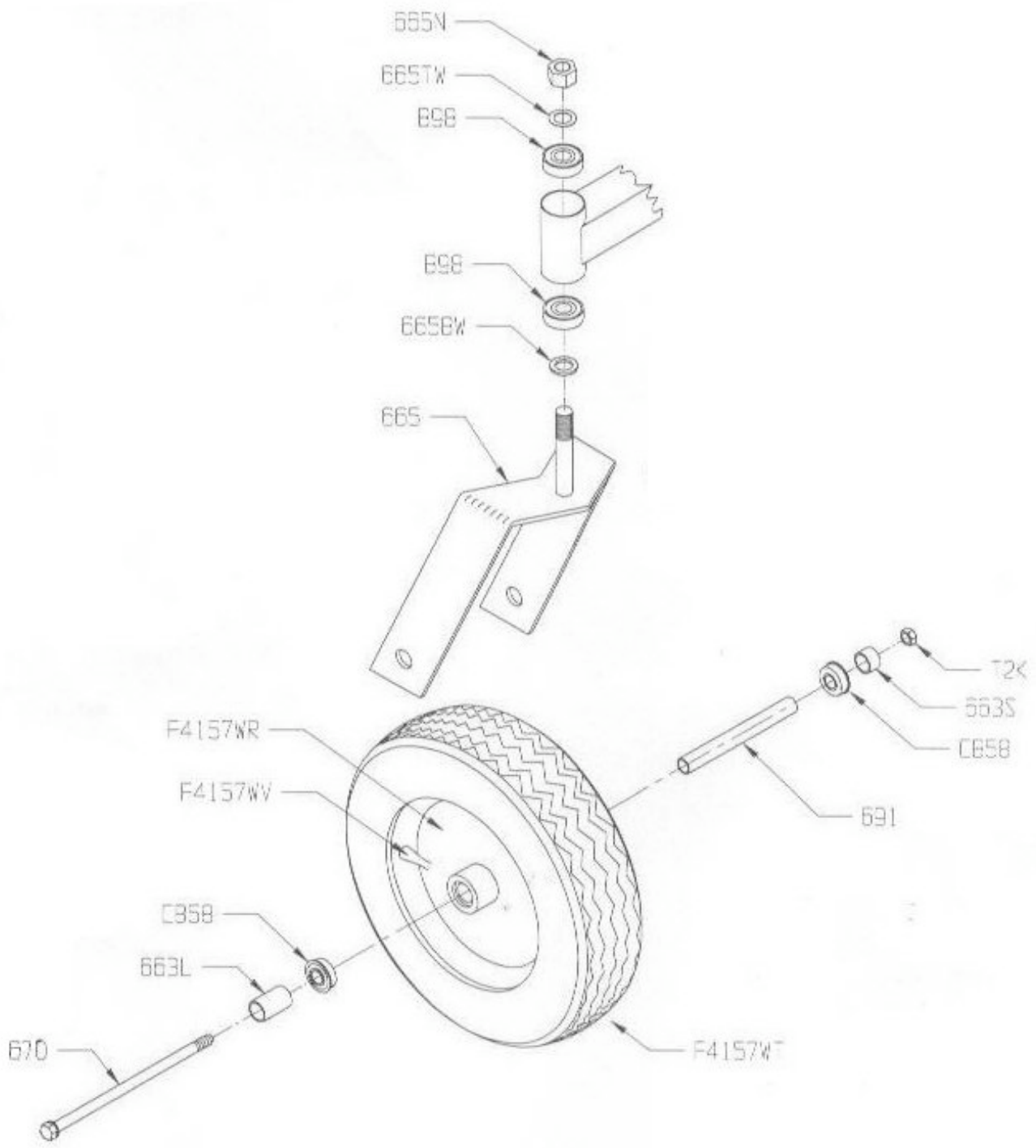

Figure 6



CASTER ASSEMBLY
 FIGURE 7

Item #	Description	Part #
1	Grass Chute	CH5
	Bolt/Nut	CH5B
	Spring	CH5S
2	Tire/Wheel/Bearing	F4157W
3	Right Belt Guard	6155RN
	Acorn Nut	FR154N
4	Battery Cable Red	BCSR
	Battery Cable Black	BCS
5	Height Adjust Crank	H7N
	Plastic Bushing	T2PB
	Threaded Link	674S
	Cotter Pin	T218C
	Knob	H7K
	5/16 Pal Washer	NB117
6	Left Belt Guard	6155LN
	Acorn Nut	FR154N
7	Gas Tank	6102T
	Gas Cap	6102NC
	Gas Tank Mount	6102N
	Rubber Bushing	AS119
	Fuel Shutoff Valve	AS120
	Fuel Line Hose Clamp	6FLC
	Fuel Line	6102FLN
8	Height Adjust Crank	H7N
	Threaded Link	674S
	Stabilizer Arm	Left-700/Right-701
	Plastic Bushing	T2PB
	Cotter Pin	T218C
	Knob	H7K
9	Tire/Wheel/Bearing	F4157WF
	Bolt/Nut	670/T2K
	Spacer (Exterior)	663S
	Spacer (Exterior)	663L
	Spacer (Interior)	691
10	Caster Fork	665
	Caster Nut	665N
	Washer Upper	665TW
	Washer Lower	665BW
11	Tongue	661
	Tongue Hinge	661A
	Tongue Extension	662
	Hitch Swivel	H10

Item #	Description	Part #
12	Safety Hitch Pin	H11
13	Red Safety Rope	H9B
14	Blade Engage Tether (Black)	BT44
15	Blade Engage Lever T60	BEA60
	Engage Bushing	681S
	Bolt/Nut	681B
	Lever	681N
	Lever Knob	B19
	Rod Spring	B25RT
16	Belt	66LR
17	Key Switch	KS12
18	Blade Driver Center	B99CCS (for list see fig 1)
19	Throttle	686
20	Idler Bracket	678
21	Idler Pulley	B527
22	Blade Driver Right	B99RS
23	Blade Driver Left	B99LS
24	Idler Rod/ Spring	B25R6
25	Idler Pulley	B527
	Engine Idler Bracket	681N
26	Engine Belt	644
27	Anti-Scalp Roller	SWR3
	Bolt/Nut	BR4/BR47N
28	Anti-Scalp Roller	SWR3- 2 Sets
	Bolt/Nut	BR7/BR47N
29	Rear Axle	664N

Items Not Shown

30	Wiring Harness	WHN60B (Briggs)
	Wiring Harness	WHN60T (Tecumseh)
31	Starter Relay	SOL NEW
32	12 V Battery	BAT
33	Oil Drain Valve	AS122
34	Engine Pulley	688
35	Engine Pulley Spacer Long	689L
	Engine Pulley Spacer Short	689S
36	Key Stock	688K
37	Engine Pulley Washer	699
38	Engine Pulley Bolt	6100

Item #	Description	Part #
39	Bearing, Flanged 3/4 ID	CB58
40	Bearing, Flanged 5/8" ID 1 3/8"OD	F157B
41	Blade Bearing	B98

Decals and Labels

42	Warning Decal	D30
43	Danger Decal	D29
44	Caution-Deflector Decal	D36
45	Caution Hand Decal	D20
46	Speed Decal	D33
47	No Step Decal	D11
48	Blade Engage Decal	D10
49	Engine Power Decal	D28
50	Swisher Logo	D32
51	Made In Missouri Decal	D31

Additional Components

52	Engine Plate	6155NF
53	Throttle Plate	6155TH

Notes



OWNER'S MANUAL

MODEL NO.

T1260

T1360

60" UNIVERSAL TRAILMOWER

Each mower has its own model number. Each engine has its own model number. The model number for the mower will be found on the right hand side of the drive belt housing. The model number for the engine will be found on the top of the blower fan housing.

All mower parts listed herein may be ordered directly from Swisher Mower & Machine Co. Inc. or your nearest Swisher dealer.

All engine parts may be ordered from the nearest dealer of the engine supplied with your mower.

WHEN ORDERING PARTS, PLEASE HAVE THE FOLLOWING INFORMATION AVAILABLE:

- * PRODUCT - TRAILMOWER
- * SERIAL NUMBER - _____
- * MODEL NUMBER - _____
- * ENGINE MODEL NUMBER - _____
TYPE - _____
- * PART NUMBER
- * PART DESCRIPTION

TELEPHONE - 1-800-222-8183

FAX - 1-816-747-8650

SWISHER MOWER & MACHINE CO. INC.

333 E. GAY ST. P.O. BOX 67

WARRENSBURG, MO 64093

SWISHER MOWER & MACHINE CO. INC.