

MITEL MAIL™

Voice Processing Solutions



FaxMemo Manual

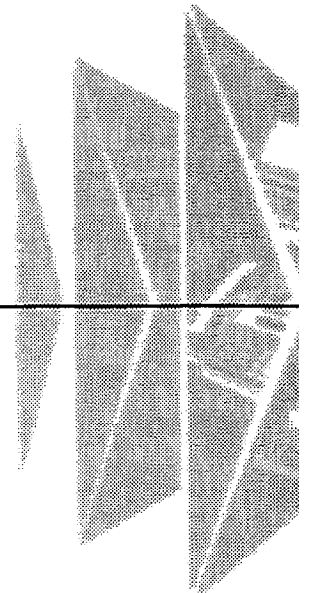

Table of Contents

About This Manual

Who Should Read This Manual.....	vii
How to Use This Manual	vii
Reference Chapters.....	vii
Task Lists	vii
Procedures.....	viii
Menu Maps and Other Navigation Aids.....	viii
Worksheets.....	ix
Conventions Used in This Manual	ix
Reader Advisories	x
Before You Start.....	xi
Console Tips and Techniques	xi
Preparing for a Configuration Session	xiii

1 FaxMemo Features and Functions

FaxMemo Applications	1-2
Fax Mail.....	1-2
Fax Broadcast	1-3
Guaranteed Fax	1-3
Fax Publishing.....	1-3
Walkaway Fax	1-3
FaxMemo Flexible Configuration	1-4
Class of Service Options	1-4
Cover Page Options	1-5
Billing and Statistics	1-6
FaxMemo Hardware	1-6
Equipment Supplied With FaxMemo	1-7
Series 6 Server Requirements.....	1-7

2 Planning Outside Caller Access

DID Fax Call Routing	2-2
Switch Integration Fax Call Routing.....	2-2
Switch TIE Trunk Integration Fax Call Routing	2-5
General Access Fax Call Routing.....	2-6

3 Hardware Installation Planning

How Fax Cards and Line Cards Communicate	3-1
FaxMemo Application Port Requirements	3-2
Fax Port Planning for Fax Mail	3-2
Fax Port Planning for Fax Broadcast.....	3-2
Fax Port Planning for Guaranteed Fax.....	3-2
Fax Port Planning for Fax Publishing	3-3
Fax Port Planning for Walkaway Fax.....	3-3
FaxMemo Hardware Configuration Rules.....	3-3
FaxMemo Card Planning Worksheet.....	3-5
Task List and Procedures	

4 Software Configuration Planning

Planning Your FaxMemo Configuration.....	4-1
Offline Configuration	4-1
FaxMemo Classes of Service (COSs)	4-1
Fax Features	4-2
Fax Limits	4-7
Fax Networking Features.....	4-9
FaxMemo and RCOS.....	4-9
Adding FaxMemo Options to COSs.....	4-9
FaxMemo Mailboxes.....	4-12
Fax Mail Mailbox Configuration.....	4-12
Fax Broadcast Mailbox Configuration	4-13
Guaranteed Fax Mailbox Configuration	4-14
Fax Publishing Mailbox Configuration.....	4-15
Company Fax Cover Page.....	4-17
Task List and Procedures	

5 FaxMemo Billing and Statistics

Billing Parameters	5-1
Messages Received	5-1
Disk Usage	5-3
Fax Statistics	5-4
Mailbox Statistics	5-4
System Statistics	5-4
Fax Group Usage Report.....	5-5
Task List and Procedures	

6 FaxMemo Troubleshooting

Configuration Problems.....	6-1
Hardware Problems.....	6-1

Worksheets

List of Centigram Procedures

Index

Menu Maps

About This Manual

This manual describes how to configure the FaxMemo software in any of the Centigram Series 6 Communications Servers:

- Model 640
- Model 120
- Model 70

Who Should Read This Manual

This manual is intended for technicians and administrators who are responsible for configuring the FaxMemo application on the Centigram Series 6 server.

How to Use This Manual

This manual contains detailed reference information, a list of tasks that you can perform, a collection of procedures for performing the tasks, and reader aids such as menu maps.

Reference Chapters



Use the material in chapters 1 through 6 for detailed inquiry into the installation and configuration of FaxMemo in a Centigram Series 6 Communications Server. These chapters discuss how components are related, elaborates on concepts, gives operational details, and contains all necessary tables and figures about configuration. Use the *Centigram Series 6 Installation and Service Manual* appropriate for your platform for an actual server installation and the *VoiceMemo Reference and Configuration Manual* for VoiceMemo software configuration.

Task Lists



Task lists follow Reference chapters that include procedures. Use the task list, starting with a principal task (shown in **boldface**), to install and configure FaxMemo. Each task listed is described in more detail in a procedure. The task list is alphabetized, which helps most readers find the desired task (and procedure)

quickly. No particular sequence of tasks is implied. The following example shows how a task list is organized:

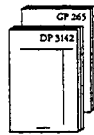
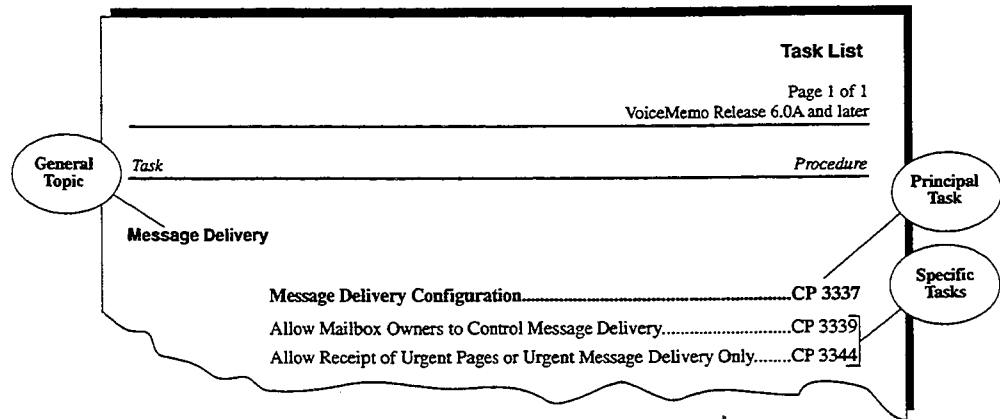

Procedures

Procedures follow the task list in the Reference chapter. Follow the steps in Centigram Procedures (CPs) to accomplish the desired tasks. Readers familiar with a Centigram Series 6 server can use the CPs as a checklist if desired, while readers new to a Centigram Series 6 server can use CPs for step-by-step instructions.

A reference column in each CP contains pointers, when necessary, to supplemental information such as another procedure, another manual, a technical reference, or a menu map.

Each CP is numbered for document identification and referencing; numbering does not indicate a sequence of performance. A numerical list of all CPs in this manual is also provided. It gives each CP's title, Chapter number, and which other procedures either call it or are called by it.

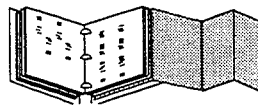

Menu Maps and Other Navigation Aids

Most of the documents in the new Centigram Series 6 document library have menu maps. You can refer to these document navigation aids at any point to help you reach a menu. And don't overlook the index; it is the fastest way to find all references to a specific topic.

Worksheets



You will find blank worksheets in the back of this manual. Instructions for completing the worksheets are in the Reference chapters. Many of the CPs assume you have completed the appropriate worksheet.

Conventions Used in This Manual

The procedures in this manual use the following conventions to describe how you enter FaxMemo configuration information and how information is displayed on the Centigram Series 6 server console:

Press Enter Press the **Enter** key. For example, “Press **Enter** if the current number is correct.” On some keyboards, this key is labeled “Return” or has a return arrow (↵) on it.

Enter Type the text shown, then press the **Enter** key. For example, “Enter the line **number** (1-24)” means type a number from 1 through 24, and then press the **Enter** key.

bold Words or characters in bold type indicate either a value to be entered by you exactly as shown or, when used to indicate a variable entry, describe the type of value to be supplied by you. See example above.

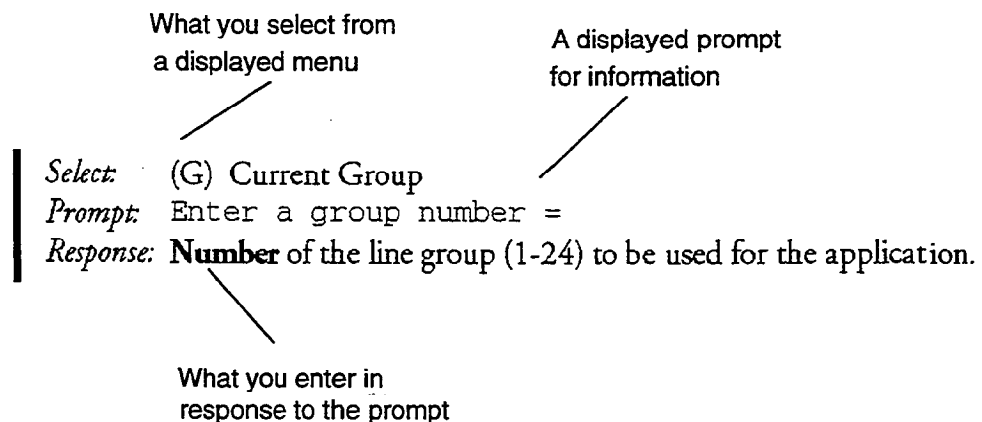

Note: Unless otherwise stated, press **Enter** after each response you enter.

Reader Advisories

Reader advisories used in this manual are shown below.

Note: Information especially useful in relation to this procedure.



CAUTION!

Information that helps you prevent equipment or software damage.



CAUTION!

Information that helps you avoid electrostatic discharge (ESD) damage to the equipment.



WARNING!

Information that helps you prevent an interruption to telecommunications traffic.



WARNING!

A hazard that can cause you personal injury.



DANGER!

Warns of a condition that could severely injure or kill you.

Before You Start

This manual assumes that you are familiar with using a console and keyboard. This section describes how to use the Centigram Series 6 server effectively.

Console Tips and Techniques

The tips and techniques offered in the following paragraphs can make configuration entry sessions at the Centigram Series 6 server maintenance console more productive.

Viewing Menus

- When you finish entering a value for a parameter, the server displays an abbreviated form of the current menu, called the “short menu.” To view the complete current menu when a short menu is displayed, just press **Enter**.
- To return to the Main Menu from any VoiceMemo application configuration menu, press **X** (Exit), until the Main Menu appears.

Accepting Defaults

- To accept a default displayed in a *prompt*, just press **Enter**.
- To accept a default displayed in a *menu*, no action is necessary.

Avoiding Automatic Exit



CAUTION!

The Centigram Series 6 server “times out” after 15 minutes. This means that if you do not enter anything at the console for 15 minutes, the server automatically exits from the current program. When this happens, all work that has not been saved on the disk is lost.

To avoid being timed out and losing your work, follow these steps:

1. When you need time to think, write down the name of the current menu.
2. Exit to the (server) Main Menu.
3. When you want to continue your work, enter the appropriate menu options to regain your place.

If you find that the Centigram Series 6 server has timed out, follow the steps below. If your screen is blank, press any key to reactivate the screen and then continue with these steps.

1. Press any key to start the login sequence.
2. Enter your user ID and password (if requested).
3. Starting from the Main Menu, enter menu options to proceed to the menu from which the server timed out.
4. Reenter data as needed to regain lost work.

Quitting an Entry Session

At any point during entry of offline or online parameters, you can quit. Quitting discards all parameter entries you have made and leaves the VoiceMemo application configuration the way it was before you started entering parameters.

To quit from the VoiceMemo Configuration Offline or Online Menu:

Select: (Q) Quit -- Forget Changes

Prompt: Quit and forget changes? (y/n) =

Response: Y to return to the VoiceMemo Configuration Main Menu.

Shortcut Commands

You can use the Ctrl (Control) key or the / (slash) key while simultaneously pressing another key to execute shortcut commands at an Centigram Series 6 server maintenance console.

To do this...	Type...
Activate a timed-out console.	any key
From the offline or online menus, or FCOS, LCOS, GCOS menus, return to the VoiceMemo Configuration Menu and save any entries.	/X
From the offline or online menus, or FCOS, LCOS, GCOS menus, return to the VoiceMemo Configuration Menu without saving any entries.	/Q Y
Stop scrolling a displayed report.	Ctrl-S
Resume scrolling a displayed report.	Ctrl-Q
Return to the VoiceMemo application when a # or \$ prompt is displayed.	Ctrl-D or type exit

Preparing for a Configuration Session

Before you begin a configuration session, you need the following:

- The *VoiceMemo Reference and Configuration Manual*
- A Centigram Series 6 server maintenance console (video monitor and keyboard) and VoiceMemo module, with power on
- At least two telephones for configuration testing
- A blank 3.5-inch diskette on which you can copy your configuration
- Completed worksheets (an initial supply of blank worksheets is included in the *VoiceMemo Reference and Configuration Manual*)

1 FaxMemo Features and Functions

FaxMemo is an optional feature that allows VoiceMemo users and outside callers to exchange faxes through user mailboxes and special mailboxes. It consists of one or more FaxMemo cards and software integral to the Centigram Series 6 Communication Server, and provides a set of fax-related features and limits that you can assign to VoiceMemo mailboxes.

In a common fax transmission, the sender inserts a document into the sending fax machine. The document is scanned and sent as data to the receiving fax machine, where it is printed out, as shown in Figure 1-1.



Figure 1-1 Common Fax Transmission

With FaxMemo, fax documents are stored electronically as “fax messages” in VoiceMemo mailboxes. From there, faxes can be delivered to any fax machine at any time, distributed to other mailboxes, sent over a network, or viewed on a PC (requires the OneView optional feature). Figure 1-2 shows the basic operation of FaxMemo.

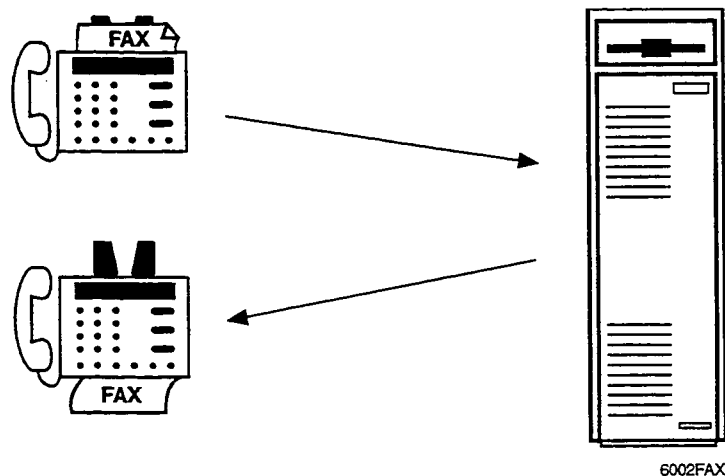

Figure 1-2 Fax Transmission With FaxMemo

FaxMemo overcomes many of the problems inherent in typical fax communication:

- Callers sending a fax do not have to wait due to the receiving fax machine being busy with another transmission.
- Faxes are stored in password-protected user mailboxes. Faxes do not sit at the fax machine for anyone to read.
- Recipients receive notification when a new fax arrives. Incoming faxes do not sit for days because recipients do not know they are there.
- Faxes can be annotated with voice messages (also called voice coversheets), relieving the sender of typing out explanatory notes.
- The recipient decides when and where a fax is printed out. For example, a FaxMemo user away from the office could call his VoiceMemo mailbox and direct a fax, deposited there by someone else, to be delivered to his hotel, the airport, or wherever there is a convenient fax machine. After reading the fax, he could call back into his mailbox and send the fax to another party, perhaps a prospect waiting for a quotation.

For a description of end-user features and functions, see the *User Guide for VoiceMemo and FaxMemo*.

FaxMemo Applications

FaxMemo applications include Fax Mail, Fax Broadcast, Guaranteed Fax, Fax Publishing, and Walkaway Fax. You can use one or more of these applications, in any combination. For more information about planning and configuring these applications, see the “Software Configuration Planning” chapter.

Fax Mail

Fax Mail is the most general and widely used application of FaxMemo. With Fax Mail, incoming faxes are stored electronically as “fax messages” in a user’s mailbox—the same mailbox that stores voice messages. Users are then notified of their new fax messages in the same manner as with voice messages (for example, message waiting light, pager, stutter dial tone).

By calling into their mailboxes, users can retrieve their fax messages at any time by sending them to any fax machine. In addition, users can call into their mailboxes from fax phones and retrieve their fax messages “online” at that fax machine. Users of Fax Mail have the same options that are available to them through voice mail: fax messages can be played, answered, or given to another mailbox, distribution list, or off-system telephone (fax) number.

Fax Broadcast

Fax Broadcast allows a user to make and send a fax message simultaneously to multiple destinations using a distribution list. The destinations can include any other users' mailboxes, users on another VoiceMemo system connected with Centigram's MESA-Net digital network, or outside telephone numbers. For example, a product manager could disseminate price changes to the sales force with a copy of the new price list and an attached voice message explaining the changes. Fax Broadcast messages can be scheduled for future delivery (when rates are lower), and the Series 6 server can automatically retry calls to numbers that are busy or do not answer.

Guaranteed Fax

With FaxMemo, delivery of incoming faxes can be guaranteed even when the company or department fax machine is busy, runs out of paper, or is otherwise disabled. One or more Guaranteed Fax mailboxes are assigned to a hunt group with the fax machine. When the machine is busy, the incoming faxes are routed to and stored in the mailboxes; the caller never realizes that the fax did not go directly to a fax machine. The mailboxes then automatically and continually try to deliver the stored faxes to the same or another fax machine.

Fax Publishing

You can configure a FaxMemo mailbox to deliver a voice message and a fax to any caller on reaching the mailbox. This provides a convenient way to publish frequently requested information to employee users, customers, or any outside callers.

The caller can reach the mailbox containing the appropriate information directly or be led by voice prompts through a mailbox tree or chain structure. The mailbox containing the fax can do either of the following:

- Play a voice coversheet or a menu or both, giving the caller the choice to either receive the fax online or enter a telephone number for delivery of the fax.
- Immediately begin transmitting the fax.

Walkaway Fax

Walkaway Fax appears to the sender exactly like a regular fax machine. With this feature, callers dial a telephone number (from a fax machine or a PC running fax software) and immediately send a fax, without a voice coversheet, directly into a user's mailbox. Callers do not have to respond to prompts or monitor the call. The walkaway Fax Mailbox listens for fax tone while playing a greeting, and if detected, receives the incoming fax. If none is detected, normal message recording ensues.

FaxMemo Flexible Configuration

The FaxMemo configuration software includes menu selections so the system administrator can assign FaxMemo resources to line groups and add the fax options to existing FCOSs (Features Classes of Service), LCOSs (Limits Classes of Service), and NCOSs (Network Classes of Service). RCOS (Restriction Class of Service) settings can also be used to control fax delivery destinations.

Class of Service Options

Following are lists of FaxMemo feature, limit, and network options. Each of these options is described in detail in chapter 4, Software Configuration Planning.

FCOS Fax Options

- Receive fax messages
- Make fax messages
- Give fax messages
- Deliver fax to default fax phone number
- Deliver fax online
- Deliver fax to designated telephone number
- User changeable default fax phone number for fax delivery
- Fax on demand
- Receive fax messages only
- Automatic receipt for fax message sent
- Fax cover page
- Walkaway Fax
- Discard fax messages after delivery
- Fax verify
- Deny user change of fax cover page
- Display a FROM field on fax cover pages
- Display a promotional message on fax cover pages
- Automatic fax retrieval
- End of session delivery
- Retrieve all unplayed faxes
- Receive fax on record timeout
- Play fixed initial prompt for walkaway fax

LCOS Fax Options

- Maximum number of digits allowed for the fax delivery phone number
- Number of fax messages per mailbox
- CNG tone detection length
- Fax delivery retry frequency

- Fax delivery retry interval
- Retention time for played, unplayed, and urgent fax messages
- Retention time for fax receipts

NCOS Fax Options

- Make fax message to the network
- Give fax message to the network
- Answer fax message to the network

Cover Page Options

FaxMemo provides three cover page options for faxes sent out from the server:

1. Each mailbox owner can have a personal fax cover page. This option allows a mailbox owner to fax their own cover page into their mailbox (via the User Options Menu). The system sends the personal cover page with any fax sent from the mailbox to a telephone number. Faxes retrieved online do not include a cover page.
2. The system can send a company cover page. If a cover page is put in the administrator's mailbox, it becomes the cover page for all faxes sent from that line group for all mailboxes that do not have a personal cover page. You can assign separate administrator's mailboxes, each with a different cover page, to each outbound line group with fax capability.
3. The system generates a default cover page for any mailboxes that do not have a personal or company cover page. The default cover page contains the following information:
 - A "To" field showing the name of the sending mailbox
 - A "From" field, indicating the system or service that the fax was sent from (optional)
 - The number of pages in the fax
 - A time field, showing the time that the fax was sent, including a time zone designator
 - The date that the fax was sent from the mailbox (not the date the fax was sent to the mailbox)
 - A promotional or greeting message of up to 60 characters (optional)

Note: If feature bit 200 is not enabled for a mailbox, the system does not send any cover page.

Billing and Statistics

The Series 6 server keeps records of fax traffic, both at the system and mailbox level. Mailbox owners can be billed for faxes sent and received, either in terms of the number of faxes, or in terms of the total number of pages

Series 6 servers offer two other methods of billing mailbox owners for fax usage. Fax transactions are recorded in Call Detail Recorder records, which can be downloaded to a computerized billing system for interpretation and billing. Or the server can place fax calls using mailbox owners' long distance carriers and calling card numbers. This can eliminate the need for any further billing, because there is no toll incurred by the server.

Fax statistics reports are also available to monitor the use of fax groups and fax storage.

See the FaxMemo Billing and Statistics chapter for more information on these topics.

FaxMemo Hardware

The MVIP fax cards used in Series 6 servers work with the line cards to provide fax services during call sessions. The MVIP fax cards do not have direct telephone interfaces. They communicate over the MVIP bus with the line cards, which contain the telephone interface hardware and control the call sessions. -Figure 1-3 illustrates these communication paths.

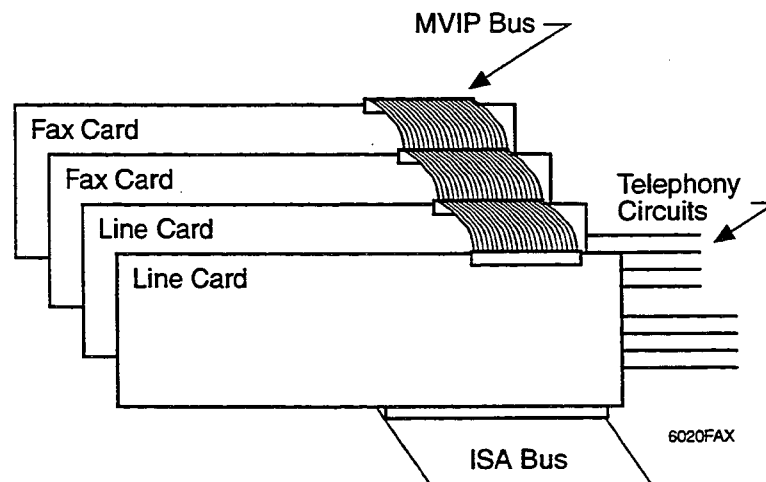

Figure 1-3 Fax Card to Line Card Communication

Because MVIP fax cards are not physically attached to an individual line or line card, they can communicate over the MVIP bus with any line card. In this way, they can

serve as a fax resource to any line card. MVIP fax cards can be a dynamically-allocated resource pool for several line card groups, or they can be assigned to a single line group. When a fax group is assigned to a line group and the number of fax channels is the same as the number of line ports, the fax group is *dedicated*. With a dedicated fax group, there is always a fax resource available for every line port.

See the Hardware Installation Planning chapter for a further explanation of FaxMemo hardware.

Equipment Supplied With FaxMemo

Each FaxMemo package includes the following items:

- Two 3.5-inch FaxMemo Optional Feature software diskettes
- One or more MVIP FaxMemo cards with two, four, or eight-port capacities
- One *VoiceMemo FaxMemo Manual* (this document)
- The number of user guides ordered

If any of these items are missing, contact your Centigram distributor.

Series 6 Server Requirements

FaxMemo can be installed and enabled in any Series 6 server with VoiceMemo Release 5.02 Revision A software or later. Your system must have Release 6.0 or later to use MVIP FaxMemo cards that work with line cards on the MVIP bus.

Your system must have one empty card slot for each FaxMemo card to be installed.

You must take the server out of service for about 15 to 30 minutes for FaxMemo card installation. The total time required depends on the number of FaxMemo cards that you will install. After you install the hardware and configure the software, you must activate the new configuration, resulting in a momentary loss of call processing capabilities.

Note: If your Series 6 server was ordered as a new system with the FaxMemo optional feature, the FaxMemo cards and software were installed at the factory.

2 Planning Outside Caller Access

With the FaxMemo optional feature, outside callers can leave fax messages for mailbox owners just as if they were sending a fax to a fax machine. In most instances, callers believe they are dialing directly to a fax machine, and are not prepared to perform any special functions to deliver a fax. Therefore, for the fax mail application to be effective, the system must allow the callers to deposit faxes into the appropriate mailboxes without any unexpected requirements.

In most non-service provider FaxMemo installations, mailbox owners have two mailboxes on the system. The first is their standard mailbox where they receive and play their messages. The second is a broadcast mailbox with walkaway fax enabled which is transparent to the mailbox owner and automatically sends fax messages into the mailbox owner's standard mailbox upon message receipt, as shown in Figure 2-1. The reason for the broadcast mailbox is to allow mailbox owners to publish a telephone number where callers can send a fax directly to them. This second number goes directly to the broadcast mailbox without first ringing at any telephone. This allows for a situation that is familiar to both the caller and the mailbox owner.

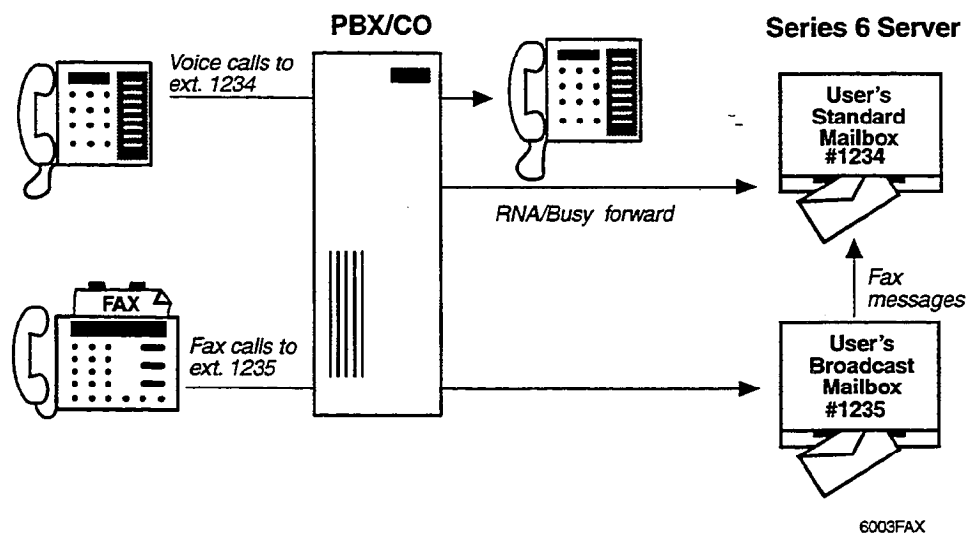

Figure 2-1 The Broadcast Fax Mailbox Setup

There are several ways that callers sending faxes can be routed to the correct mailboxes. These include DID routing, Switch Integration routing, Switch Tie Trunk Integration routing, and General Access. It is possible to combine two or more of these methods to meet user needs and cost requirements.

Note: The primary purpose of the call routing scenarios in this chapter is to show possible switch connections. There are many ways to configure line groups and assign fax resources. Fax resources can be dedicated to a single line group or shared by inbound and outbound line groups.

DID Fax Call Routing

The simplest routing method is to connect a second FaxMemo-equipped inbound line group to DID trunks directly from the CO. In this scenario, each mailbox owner that has fax mail capability is provided with a DID telephone number that allows a caller to deposit a fax message, or voice and fax message, into a broadcast mailbox on the system. Because the DID method involves additional trunks from the central office that bypass the PBX, it can be used in any switch environment. It does incur the expense of the DID lines and DID numbers for all users with FaxMemo capability. Figure 2-2 shows this configuration.

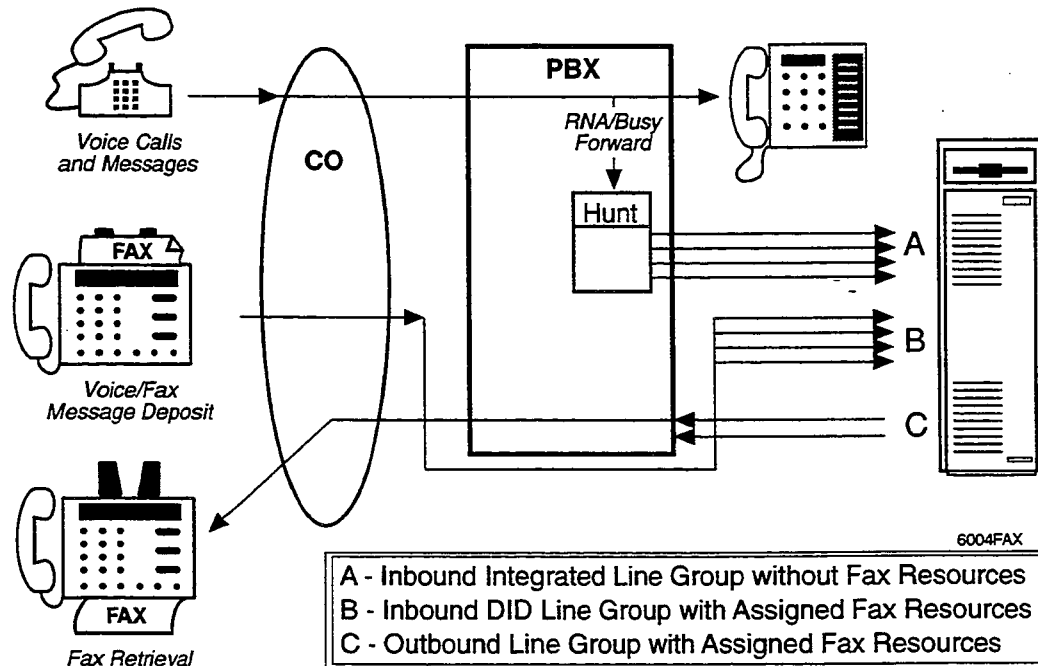

Figure 2-2 DID Fax Call Routing

Switch Integration Fax Call Routing

Fax Mail is supported by most of Centigram's PBX and Centrex integrations. Switch integration works the same way as DID fax call routing in that the caller is directed immediately to the appropriate mailbox. This method requires every person with Fax Mail capability to have a second DID number (both CO and PBX) that

goes to a software-only *phantom* extension on the PBX. The phantom extension numbers must correspond to the broadcast mailbox numbers, and must be hard-forwarded to the VoiceMemo pilot number. This method of fax call routing is shown in Figure 2-3.

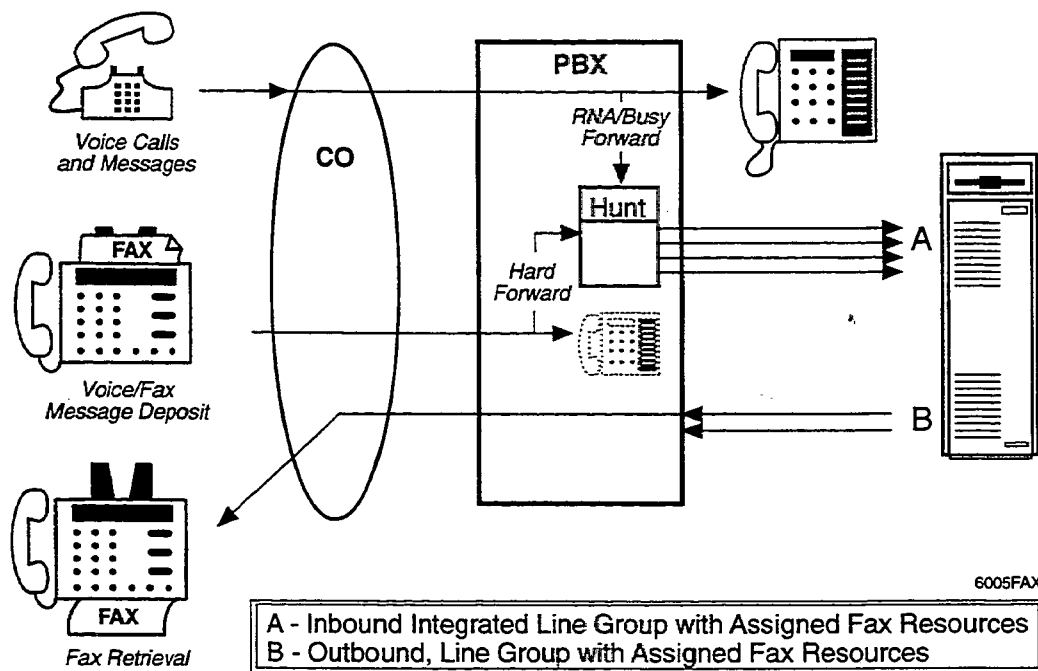

Figure 2-3 Switch Integration Fax Call Routing, Method 1

The advantage of this method is that fax calls are answered immediately by the desired party's FaxMemo broadcast mailbox, and it does not require any trunks directly from the central office. However, it does require the expense of an additional DID number for each mailbox owner with fax capability.

Not all switches support a phantom extension capability. If your switch does not support this, then you must use another method. If your switch supports multiple in-bound line groups, you can use the second method of switch integration.

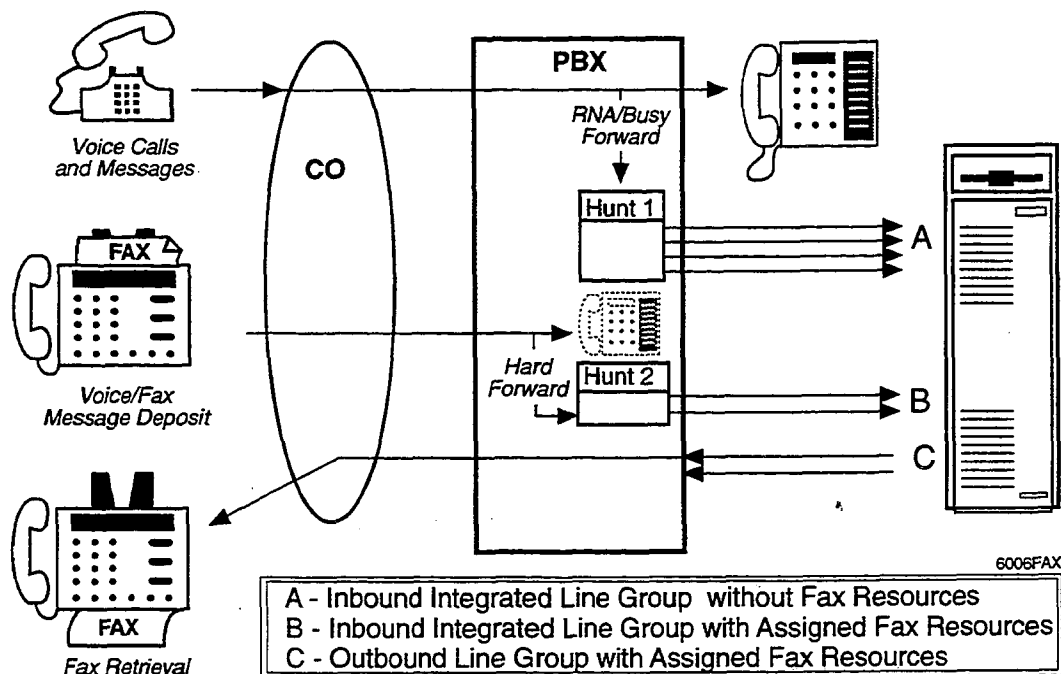

Figure 2-4 Switch Integration Fax Call Routing, Method 2

Switch TIE Trunk Integration Fax Call Routing

This method utilizes the tandem switching capabilities of many PBXs. If the integration routing method is not supported by your switch, this method still allows you to use a line group to the switch from the CO, but could require additional cards in the PBX. This method also requires everyone with fax capability to have a second DID number from the CO.

When the switch receives a call on one of the DID lines, it passes the call and its related information to the Series 6 server over a set of TIE trunks. The call information allows the server to connect the caller to the appropriate mailbox. Figure 2-5 shows this method of fax call routing.

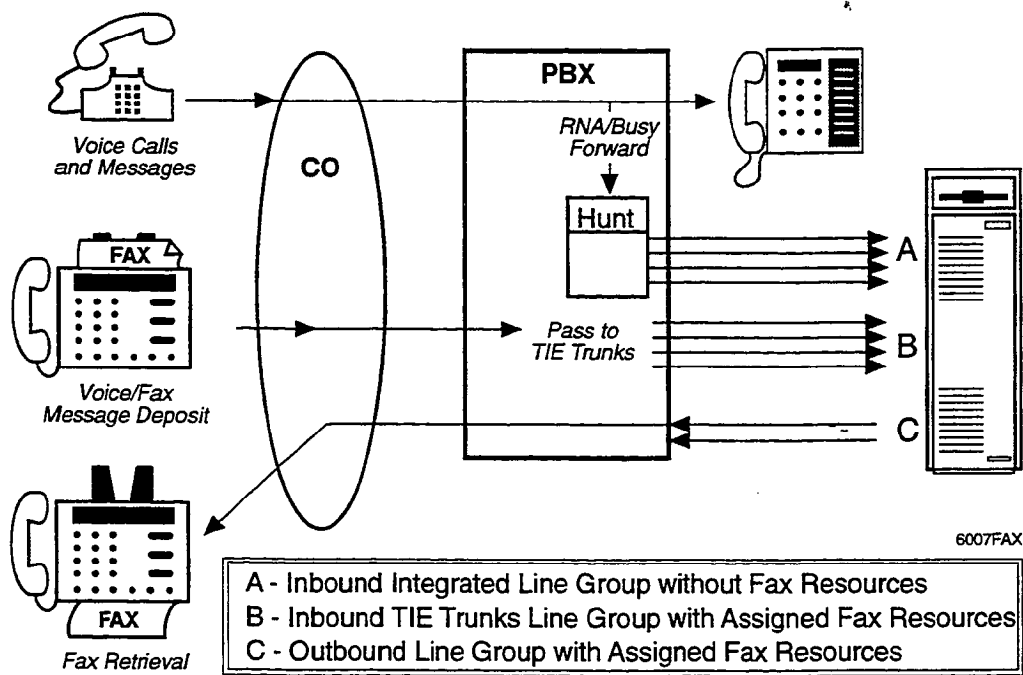

Figure 2-5 Switch TIE Trunk Integration Fax Call Routing

One disadvantage of TIE trunk integration is that many PBXs do not allow callers to transfer on TIE trunks. If most of the calls on these trunks are fax calls though, few callers need to transfer.

General Access Fax Call Routing

The alternative to DID or switch integration routing is to have a single fax message number that, upon answering, requests that the caller enter the mailbox number of the party who will receive the fax. Figure 2-6 shows these calls routed directly to the inbound line group. The advantage of this access method is the security and screening that it offers, since only those who know the mailbox number can access it. This method is available on any PBX or key system with no special hardware or software requirements.

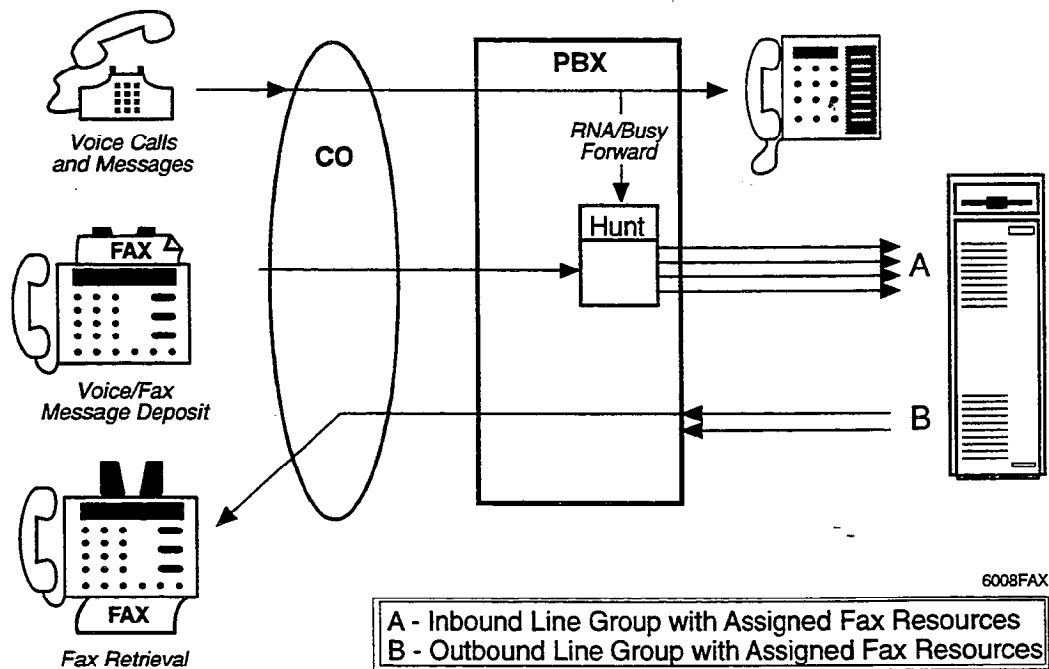

Figure 2-6 General Access Fax Call Routing

3 Hardware Installation Planning

Planning the hardware to support FaxMemo involves:

- Knowing how you will route fax calls to the Series 6 server (Chapter 2)
- Understanding the relationship of fax cards to line cards
- Understanding the requirements of the FaxMemo application(s) that you will use on your system
- Knowing the expected volume of fax call traffic for your system
- Following the five hardware configuration rules

You need all of this information to fill out the FaxMemo Card Worksheets.

How Fax Cards and Line Cards Communicate

Fax cards and line cards work together to provide fax services on a Series 6 server. The line card handles all line signaling, supervision, and voice/fax transmissions. The fax cards have no direct connection to telephone services, but communicate with the line cards over the MVIP bus, as shown in Figure 3-1.

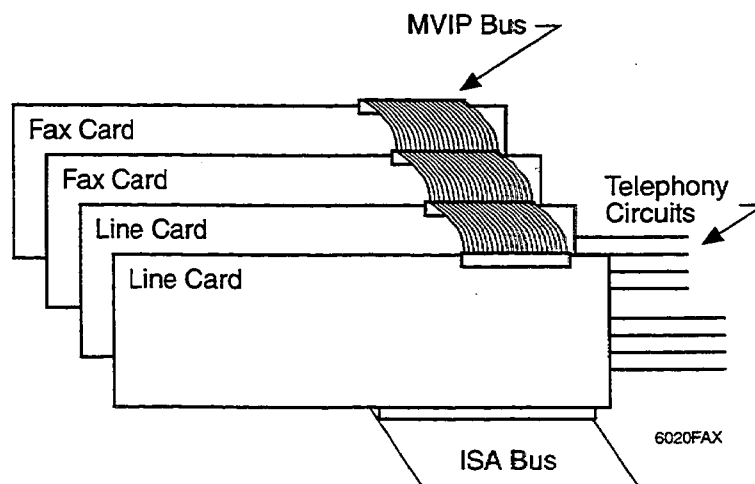

Figure 3-1 Fax Card to Line Card Communication

A voice port requests a fax resource over the MVIP bus when it detects an incoming fax tone during a walkaway fax call session or when a user pushes a key to leave a fax.

Once an association with a fax channel is made, the voice port passes all fax-related data to the fax channel, which converts it into a format suitable for storage on the system hard disks. When the fax transmission/reception is complete, the voice port releases the fax channel and continues with the call session. The fax channel is immediately available to service other voice ports.

FaxMemo Application Port Requirements

Each FaxMemo application has unique requirements for fax-equipped ports on a Series 6 server. You can combine any or all FaxMemo applications on the same line groups, provided you allow enough FaxMemo cards to carry the call traffic.

Fax Port Planning for Fax Mail

For general purpose Fax Mail between outside callers and mailbox owners, and between mailbox owners, you need fax groups connected with both inbound and outbound line groups. The requirements parallel those for voice message handling. Inbound line groups with fax are required for outside callers or users depositing faxes in mailboxes and for users retrieving faxes online. Outbound line groups with fax are required for users to deliver their faxes to a fax machine, or to send a fax to an off-system number. (The "give fax message" option is handled by software and does not use a fax port.)

Fax Port Planning for Fax Broadcast

Fax Broadcast is like Fax Mail, but with many recipients for each fax message. Fax Broadcast allows a user to send a fax message to a number of people by using the VoiceMemo distribution list features. The sender uses an inbound fax-equipped port to send the fax to a personal distribution list or to a master broadcast mailbox. The server distributes the fax directly to on-system users (no fax port is needed for distribution). Fax groups connected with inbound and outbound line groups are required for users to retrieve their faxes as described in Fax Mail.

If users broadcast often to off-system numbers, you must size the system with the appropriate number of outdialing ports that can use fax resources.

Fax Port Planning for Guaranteed Fax

In Guaranteed Fax, you include FaxMemo mailboxes in a hunt group with company or department fax machines to handle the overflow when the machines are busy or out of service. Guaranteed Fax requires an inbound line group with fax for the mailboxes on the hunt group. Faxes outbound from these mailboxes to fax machines need outbound fax port capability. If traffic allows, you can assign the outbound port capability to Fax Mail or Fax Broadcast outbound ports.

Fax Port Planning for Fax Publishing

A Fax Publishing application usually has some number of documents stored in special fax mailboxes on the Series 6 server. Callers that reach the system use their push-button phones to request that certain documents be faxed to them. Fax Publishing requires a minimum number of fax channels connected with inbound line groups to place the documents in the system for retrieval.

If you allow callers to receive the fax documents online (that is, while calling from a fax machine), you need fax groups connected with an inbound line group. If you require callers to input the phone number of their fax machine for delivery, you only need fax groups connected with an outbound line group. If you offer callers their choice of methods, you need fax groups for both inbound and outbound line groups. You might require dedicated fax groups, depending on the number of calls expected and the number of faxes published simultaneously.

Fax Port Planning for Walkaway Fax

Walkaway Fax is a special feature that you can activate for Fax Mail, Fax Broadcast, and Guaranteed Fax applications. When Walkaway Fax is activated, callers can send from a normal fax machine (or PC with a fax card) to the Series 6 server just as if they were sending to another fax machine – they do not need to listen or respond to any voice prompts before sending a fax.

Walkaway Fax by itself only requires fax groups connected with inbound line groups to deposit faxes. Depending on which other FaxMemo applications you are using with Walkaway Fax, mailbox owners may be able to use the same inbound line group to retrieve the faxes on line, or you may need fax groups on an outbound line group so that users can deliver their faxes to fax machines.

FaxMemo Hardware Configuration Rules

It is easier to plan fax cards if you familiarize yourself with these five hardware configuration rules.

Rule #1: Every voice port that either sends or receives a fax must have access to a fax channel.

Any call that either deposits a fax or retrieves a fax message on line (caller is calling from a fax phone) must be answered by a voice port with access to a fax channel. Likewise, any outbound call that delivers a fax must be made from a voice port with access to a fax channel. Voice ports in line groups that are not assigned to a fax group cannot send or receive faxes.

Fax channels do not have to be assigned in a one-to-one relationship with voice ports. Because the FaxMemo cards use the MVIP bus to communicate with the line

cards and do not have direct connections to specific phone lines, any channel on a FaxMemo card can service any port on any line card in the same module. In addition, fax channels are allocated dynamically – once a channel completes a session, it is available to service another session on another port.

See rule #2 and rule #3 for more information on assigning fax channels to voice ports.

Rule #2: A fax group can be shared by more than one line group.

A fax group (a defined set of fax channels) can be assigned to more than one line group, and its channels are then shared by the voice ports in those line groups. Fax groups can be shared by both inbound and outbound line groups. Figure 3-2 shows a shared fax group.

There can be more voice ports than fax channels – the fax channels are allocated as they are needed for the different call sessions. If all of the fax channels in the fax group are in use by call sessions and another call session requests a fax resource, the system informs the caller that the fax cannot be sent/received.

Rule #3: A fax group must be dedicated to a line group to guarantee availability of a fax resource.

When there is a one-to-one relationship between the number of voice ports in a line group and the number of channels in its associated fax group, the fax group is considered *dedicated* to the line group. This configuration ensures that voice ports in line groups that carry a lot of fax traffic will never be unable to get a fax resource.

A Series 6 server can have dedicated and shared fax groups, as show in Figure 3-2.

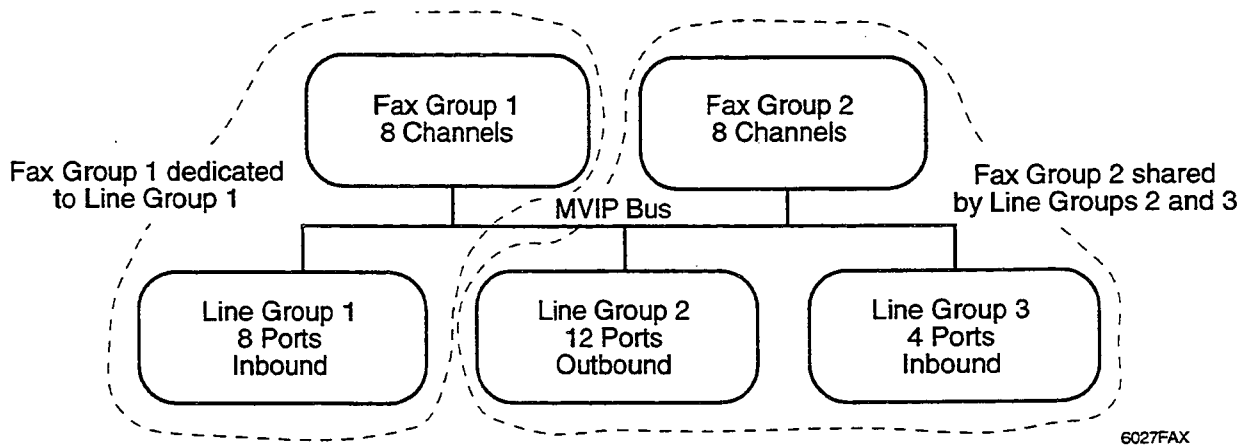

Figure 3-2 Fax Group to Line Group Relationships

Rule #4: Line groups connected to fax groups can still perform all other VoiceMemo functions.

Ports that are equipped for FaxMemo can perform any VoiceMemo function. For example, the same outbound line group that delivers faxes can also make message delivery and paging calls. Likewise, the same line group that performs telephone answering functions can also receive inbound faxes. There is no need to dedicate line groups to perform FaxMemo functions.

Rule #5: It may be a better use of system resources to have a separate line group for some fax applications.

In most FaxMemo installations, every line group in the system does not need a dedicated fax group. The only time a fax channel is absolutely required on an inbound call is when a caller sends a fax. The only time a fax channel is required on an outbound call is when the system needs to deliver a fax.

For some fax applications, such as Fax Mail, a fairly low percentage of calls involve fax transactions. The fax traffic for these applications probably can be carried by a single fax group that is shared by incoming and outgoing line groups. The number of fax channels in the fax group should be large enough to provide an acceptable grade of service to fax callers.

For other fax applications, such as Fax Publishing, it is likely that every call involves a fax transaction. You may want to have a separate line group for these applications and dedicate a fax group to the line group so that there is always a fax channel for every voice port. The line group may be incoming or outgoing, depending on whether callers must call in from a fax machine and receive faxes online (incoming), or whether they can enter a phone number for the fax to be delivered (outgoing).

By configuring some fax groups as shared and others as dedicated, you can utilize your fax resources to provide an appropriate grade of service for each fax application.

Note: If a caller on an inbound line group tries to send a fax when there are no resources available, the system plays a prompt telling the caller that it cannot process the request at that time. If there are no fax resources available for an outgoing fax call, the server retries the call (according to LCOS settings) until one is available.

FaxMemo Card Planning Worksheet

With the information that you have gathered from chapters 2 and 3, you should be able to fill in the FaxMemo Card Planning Worksheets. A sample worksheet follows. Blank worksheets for photocopying are in the worksheets section at the end of this manual. Make a copy for each server module in which you are installing FaxMemo cards.

Hardware Installation Planning

For each fax card in each module, enter the FaxMemo card serial number, the system slot number, the number of channels on the fax card, and the base I/O address (see Technical Reference 1904). Identify the fax group that each fax channel belongs to, and the line group(s) that it is connected with, and whether the fax group is dedicated to one line group or shared.

FaxMemo Card Planning Worksheet

Hardware

Module No.	Backplane Slot No.	FaxMemo Card Serial No.	Number of Channels	Base I/O Address
1	15	413	8	100
1	14	465	8	128
2	15	432	8	100
2	14	512	2	130

Configuration

Fax Group #: 1 **Module #:** 1 **Total Number of Channels:** 16

Connect with Line Group(s): 1 **Dedicated** **Shared**

Triplet (module:slot:channel)
1:15:0
1:15:1
1:15:2
1:15:3
1:15:4
1:15:5
1:15:6
1:15:7

Triplet (module:slot:channel)
1:14:0
1:14:1
1:14:2
1:14:3
1:14:4
1:14:5
1:14:6
1:14:7

Prepared By: _____ Date: _____

Installed By: _____ Date: _____

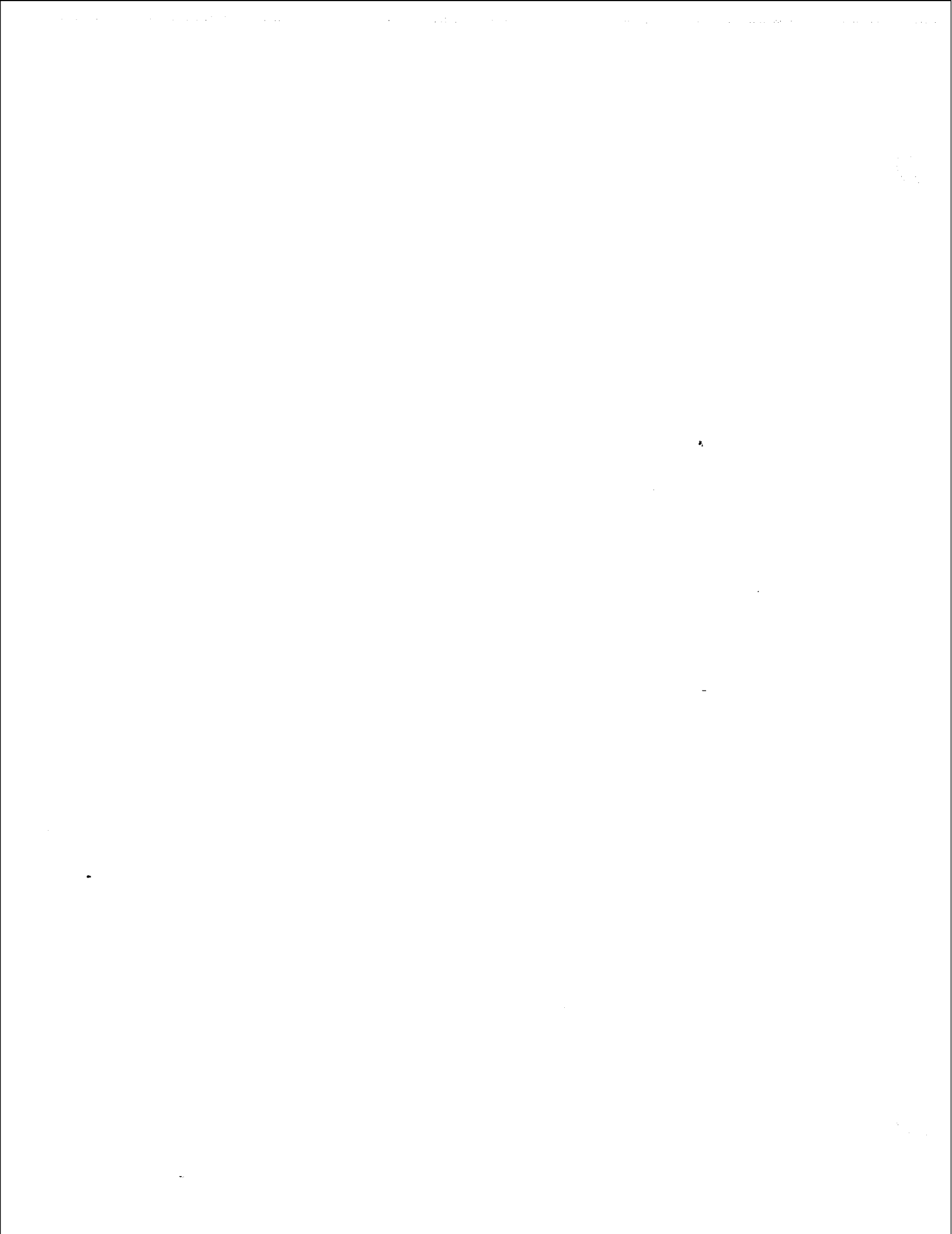

Hardware Change Task List

Page 1 of 1

VoiceMemo Release 6.0A and later

Task

Procedure

FaxMemo Hardware Changes

Replace an MVIP Fax Card.....	CP 2146
Install an MVIP Fax Card	CP 7510
Remove an MVIP Fax Card	CP 7511

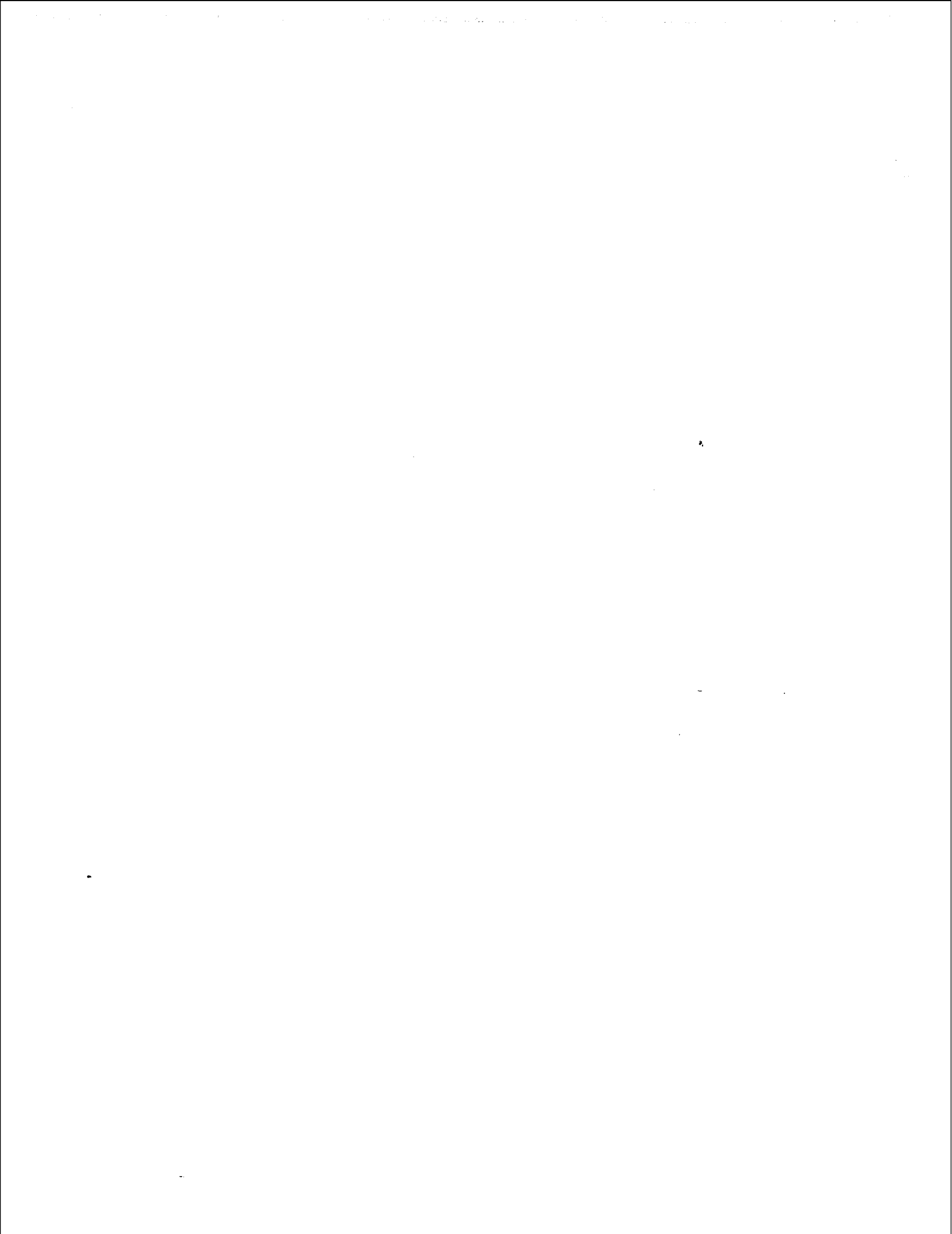

Replace an MVIP Fax Card

VoiceMemo Release 6.0A and later

This procedure describes how to replace an MVIP fax card in a Series 6 server.



DANGER!

Disconnect the system from its power source before connecting cables, components, or both.



CAUTION!

Protect your system from ESD damage during handling of all components.



WARNING!

This process requires the module to be shut down, resulting in loss of call processing capabilities. Centigram recommends that you perform this procedure during periods of low call traffic.

Note: You can find TRs referenced in this procedure in the *Centigram Series 6 Technical Reference Manual*.

<i>Step</i>	<i>Reference</i>
<p>Ⓢ Observe Precautions</p> <ol style="list-style-type: none"> Put on a grounded wrist strap, attaching the other end to the Series 6 server. Doing so protects the component from electrostatic discharge. Shut down the system, press the reset button, and turn off the power. 	CP 5700
 <p>CAUTION!</p> <p>Removing a component while the power is on can severely damage both the component you are working on and others.</p> <ol style="list-style-type: none"> Wait one minute after you turn off the power before you remove any components. The hard disk should stop spinning and be quiet. When removing a component, place it on a non-conductive surface, such as an anti-static bag. Make sure you have the anti-static bags required before you begin. 	
<p>Ⓢ Before You Begin</p> <ol style="list-style-type: none"> Configure the fax card. 	TR 1904

*Step**Reference***Ⓢ Remove the Fax Card**

6. Remove the cover on the system. On a Model 640, remove the front panel of the CPU assembly.
7. Identify the fax card to remove.
8. Using the plastic loops, remove the MVIP cable. You only need to remove the cable from enough cards so that you can access the fax card.
9. Use a screwdriver to unfasten the bracket screw that holds the fax card to the card cage.
10. Grasp the fax card firmly, and pull it straight out.
11. Place the fax card on a static bag.

Ⓢ Install the New Fax Card

12. Pick up the new fax card. Hold it with the backplane connector facing away from you.
13. Insert the fax card into the alignment grooves of the card cage.
14. Slide the fax card along the grooves until the fax card backplane connector is touching the corresponding connector on the backplane.
15. Be sure that the two connectors are properly aligned, then press firmly on the edge of the fax card until the connectors are fully seated.
16. Tighten the bracket screw that holds the fax card in the card cage.
17. Reconnect the MVIP cable to all appropriate cards.
18. Replace the cover on the system.
19. Restore power to the server.
20. If you installed the new card in a different slot, or if the replacement card is not identical to the card that you removed (same number of channels, same base I/O address), delete the old card and add the new card to the Resource Manager.

Install an MVIP Fax Card

VoiceMemo Release 6.0A and later

This procedure describes how to install an MVIP fax card in a Series 6 server.



DANGER!

Disconnect the server from its power source before connecting cables, components, or both.



CAUTION!

Protect your server from ESD damage during handling of all components.



WARNING!

This process requires the module to be shut down, resulting in loss of call processing capabilities. Centigram recommends that you perform this procedure during periods of low call traffic.

Note: You can find TRs referenced in this procedure in the *Centigram Series 6 Technical Reference Manual*.

Step

Reference

⦿ **Observe Precautions**

1. Put on a grounded wrist strap, attaching the other end to the Series 6 server. Doing so protects the component from electrostatic discharge.
2. Shut down the server, press the reset button, and turn off the power.



CAUTION!

Removing a component while the power is on can severely damage both the component you are working on and others.

3. Wait one minute after you turn off the power before you remove any components. The hard disk should stop spinning and be quiet.
4. When removing a component, place it on a non-conductive surface, such as an anti-static bag. Make sure you have the anti-static bags required before you begin.

⦿ **Install the Fax Card**

5. Set switches on the MVIP fax card.
6. Remove the cover on the server. On a Model 640, remove the front panel of the CPU assembly.

TR 1904

CP 7510

Page 2 of 2

VoiceMemo Release 6.0A and later

Step

Reference

7. Using the plastic loops, remove the MVIP cable. You only need to remove it from enough cards so that you can install the fax card.
8. Pick up the fax card. Hold it with the backplane connector facing away from you.
9. Insert the fax card into the alignment grooves of the card cage.
10. Slide the fax card along the grooves until the fax card backplane connector is touching the corresponding connector on the backplane.
11. Be sure that the two connectors are properly aligned, then press firmly on the edge of the fax card until the connectors are fully seated.
12. Tighten the bracket screw that holds the fax card in the card cage.
13. Reconnect the MVIP cable to all appropriate cards.
14. Replace the cover on the server.
15. Restore power to the server.

Remove an MVIP Fax Card

VoiceMemo Release 6.0A and later

This procedure describes how to remove an MVIP fax card from a Series 6 server.

**DANGER!**

Disconnect the server from its power source before connecting cables, components, or both.

**CAUTION!**

Protect your server from ESD damage during handling of all components.

**WARNING!**

This process requires the module to be shut down, resulting in loss of call processing capabilities. Centigram recommends that you perform this procedure during periods of low call traffic.

*Step**Reference*
 **Observe Precautions**

1. Put on a grounded wrist strap attaching, the other end to the Series 6 server. Doing so protects the component from electrostatic discharge.
2. Shut down the server, press the reset button, then turn off the server power.

CP 5700, Ch. 4

**CAUTION!**

Removing a component while the power is on can severely damage both the component you are working on and others.

3. Wait one minute after you turn off the power before you remove any components. The hard disk should stop spinning and be quiet.
4. When removing a component, place it on a non-conductive surface, such as an anti-static bag. Make sure you have the anti-static bags required before you begin.

 **Remove the Fax Card**

5. Remove the cover on the server. On a Model 640, remove the front panel of the CPU assembly.
6. Identify the fax card to remove.
7. Using the plastic loops, remove the MVIP cable. You only need to remove the cable from enough cards so that you can access the fax card.
8. Use a screwdriver to unfasten the bracket screw that holds the fax card to the card cage.

Step

Reference

9. Grasp the fax card firmly, and pull it straight out.
10. Place the fax card on a static bag.
11. Reconnect the MVIP cable to all appropriate cards.
12. Replace the cover on the server.
13. Restore power to the server.

Configuration Task List

Page 1 of 1

VoiceMemo Release 6.0A and later

Task

Procedure

FaxMemo Configuration

Add FaxMemo to a Series 6 Server	CP 6449
Configure for Fax Broadcast	CP 6453
Configure for Fax Mail	CP 6450
Configure for Fax Publishing.....	CP 6451
Configure for Guaranteed Fax	CP 6452
Setup a Company Fax Cover Page	CP 6454
Activate the Inactive Configuration	CP 7002
Add or Delete Feature Bits	CP 5011
Configure a Mailbox for FaxMemo	CP 7506
Configure Time Zones for FaxMemo.....	CP 7509
Customize a Default FCOS.....	CP 5008
Customize an FCOS Copy.....	CP 5007
Define a Fax Group.....	CP 7512
Install an Optional Feature.....	CP 5402
Set Limits for FaxMemo.....	CP 7508
Shut Down the System	CP 5700
Verify Configuration Parameters	CP 5015

Customize an FCOS Copy

VoiceMemo Release 6.0A and later

This procedure describes how to customize an FCOS by modifying a copy of an existing FCOS.

Step

Reference

1. Choose the existing FCOS you wish to use as a basis for your customized FCOS.
2. Complete an FCOS Worksheet. Blank worksheets are near the back of this manual.
3. Reach the System Configuration Menu, then go to the Feature Class of Service Menu. Enter the requested information, as described in the following steps, from your completed FCOS Worksheet.

Menu Map 11

Note: You can quit at any point in the following steps before you exit the Feature Class of Service Menu. Quitting discards all entries you have made and leaves the FCOS settings the way they were before you reached the Feature Class of Service Menu.

To quit:

Make sure the Feature Class of Service Menu is displayed (short form or long form).

Select: (Q) Quit – Forget Changes

Prompt: Quit and forget changes? (y/n) =

Response: Y for yes.

4. Number and name the customized FCOS.

Select: (C) Current FCOS

Prompt: FCOS to modify =

Response: A **number** from 18 through 20 or 25 through 640.

Select: (N) Name FCOS

Prompt: Enter FCOS name (0 - 15 chars) =

Response: Enter a descriptive **name** to accompany the customized FCOS.

5. Make a copy of the existing FCOS.

Select: (K) Copy FCOS

Prompt: FCOS to copy (? for help) =

Response: The **number** of the existing FCOS chosen to be the basis for your customized FCOS. A copy of this FCOS is created and given the number and name you assigned above.

Step

Reference

6. Add feature bits to the FCOS copy, as desired.

Select: (A) Add Features

Prompt: Features to add (? for help) =

Response: The 1 to 3-digit **numbers** of the feature bits to be added.

- Feature bits can be entered in any of the formats shown below:

A single bit, for example 208

A range of bits, for example 202-208

A series of bits, for example, 39,40,207,208

- You can mix types of entries, so you can specify all the bits necessary in one attempt. For example, this entry is valid:

208,1-7,50,53,55,6

- Do not enter spaces after commas, and do not end the entry with a comma.

7. Delete feature bits from the FCOS copy, as desired.

Select: (D) Delete Features

Prompt: Features to delete (? for help) =

Response: The 1 to 3-digit **numbers** of the feature bits to be deleted. The same rules apply to deleting bits as explained for adding bits.

8. Verify that the information you have entered so far matches your worksheet.

Select: (S) Show FCOS

Prompt: FCOS to show (? for help) =

Response: The **number** of the FCOS copy that you specified in step 4.

9. If the information matches your worksheet, customization is completed and you can save it. If the information does not match your worksheet, make the necessary corrections.

10. After verifying that your entries are correct, save the customized FCOS by exiting from the Feature Class of Service Menu.

Modify or Renumber a Default FCOS

VoiceMemo Release 6.0A and later

This procedure describes how to customize an FCOS by modifying one of the default FCOSs supplied by Centigram or by renumbering one of these default FCOSs.

Step

Reference

☺ Modifying the Default Itself

1. Choose the default FCOS you wish to modify.
2. Complete an FCOS Worksheet.
3. Reach the System Configuration Menu, then go to the Feature Class of Service Menu. Enter the requested information, as described in the following steps, from your completed FCOS Worksheet.

Note: You can quit at any point in the following steps before you exit the Feature Class of Service Menu. Quitting discards all entries you have made and leaves the FCOS settings the way they were before you reached the Feature Class of Service Menu.

To quit:

Make sure the Feature Class of Service Menu is displayed (short form or long form).

Select: (Q) Quit – Forget Changes

Prompt: Quit and forget changes? (y/n) =

Response: Y for yes

4. Specify the default FCOS to modify.

Select: (C) Current FCOS

Prompt: FCOS to modify =

Response: The **number** (1-17, 21-24) of the default FCOS.

5. Change the name if desired.

Select: (N) Name FCOS

Prompt: Enter FCOS name (0 - 15 chars) =

Response: Enter a descriptive **name** to accompany the modified default FCOS.

6. Add feature bits to the default FCOS, as desired.

Select: (A) Add Features

Prompt: Features to add (? for help) =

Response: The 1 to 3-digit **numbers** of the feature bits to be added.

- Bits can be entered in any of the formats shown below:

*VoiceMemo
Reference and
Configuration
Manual*

Menu Map 11

Step *Reference*

- A single bit, for example 208
- A range of bits, for example 202-208
- A series of bits, for example, 39,40,207,208

- You can mix types of entries, so you can specify all the bits necessary in one attempt. For example, this entry is valid:

208,1-7,50,53,55,6

- Do not enter spaces after commas, and do not end the entry with a comma.

7. Delete feature bits from the default FCOS, as desired.

Select: (D) Delete Features

Prompt: Features to delete (? for help) =

Response: The 1 to 3-digit **numbers** of the feature bits to be deleted. The same rules apply to deleting bits as explained for adding bits.

8. Verify that the information you have entered so far matches your worksheet.

Select: (S) Show FCOS

Prompt: FCOS to show (? for help) =

Response: The **number** of the default FCOS you have been working with.

9. If the information matches your worksheet, customization is completed and you can save it. If the information does not match your worksheet, make the necessary corrections.

10. After verifying that your entries are correct, save the modified default FCOS by exiting from the Feature Class of Service Menu.

☺☺ Renumbering a Default FCOS

1. Choose the default FCOS you wish to renumber. (Renumbering a default FCOS does not destroy the original default FCOS; the original default FCOS can be restored through the Use Template FCOS option in the Feature Class of Service Menu.)
2. Complete an FCOS Worksheet.

*VoiceMemo
Reference and
Configuration
Manual*

Step

Reference

3. Reach the System Configuration Menu, then go to the Feature Class of Service Menu. Enter the requested information, as described in the following steps, from your completed FCOS Worksheet.

Note: You can quit at any point in the following steps before you exit the Feature Class of Service Menu. Quitting discards all entries you have made and leaves the FCOS settings the way they were before you reached the Feature Class of Service Menu.

To quit:

Make sure the Feature Class of Service Menu is displayed (short form or long form).

Select: (Q) Quit – Forget Changes

Prompt: Quit and forget changes? (y/n) =

Response: Y for yes.

4. Specify the new number for the FCOS.

Select: (C) Current FCOS

Prompt: FCOS to modify =

Response: The new FCOS **number** (18-20 or 25-640).

5. Assign the chosen default FCOS to this number.

Select: (U) Use Template FCOS

Prompt: Overwrite current FCOS with a template (y/n) =

Response: Y for yes.

The system displays a list of the default (template) FCOSs.

Prompt: Choose a number (1-17, 21-24) from the menu:

Response: The **number** of the default (template) FCOS (1-17 or 21-24) that you want to be assigned to the current FCOS number.

The system displays a confirmation that the default (template) FCOS just specified has been renumbered. The default FCOS is now customized.

6. Save the customized FCOS by exiting to the System Configuration Menu.

Menu Map 11

Add or Delete Feature Bits

VoiceMemo Release 6.0A and later

This procedure describes how to add or delete feature bits in an FCOS.

<i>Step</i>	<i>Reference</i>
<ol style="list-style-type: none"> 1. Reach the System Configuration Menu, then go to the Feature Class of Service Menu. 2. Identify the FCOS you want to add bits to or delete bits from. <p><i>Select:</i> (C) Current FCOS <i>Prompt:</i> FCOS to modify = <i>Response:</i> Number of the FCOS (1-640) you want to add a bit to or delete a feature bit from, or just press Enter if the displayed FCOS is the one you want.</p> 3. Add the desired bits. <p><i>Select:</i> (A) Add Features <i>Prompt:</i> Features to add (? for help) = <i>Response:</i> The 1 to 3-digit numbers of the feature bits to be added.</p> <ul style="list-style-type: none"> • Bits can be entered in any of the formats shown below: <p>A single bit, for example 208 A range of bits, for example 202-208 A series of bits, for example, 39,40,207,208</p> • You can mix types of entries, so you can specify all the bits necessary in one attempt. For example, this entry is valid: 208,1-7,50,53,55,6 • Do not enter spaces after commas, and do not end the entry with a comma. 4. Delete the desired feature bits. <p><i>Select:</i> (D) Delete Features <i>Prompt:</i> Features to delete (? for help) = <i>Response:</i> The 1-to-3-digit numbers of the feature bits to be deleted. The same rules apply to deleting bits as explained for adding bits.</p> 5. Confirm the additions and/or deletions to this FCOS. <p><i>Select:</i> (S) Show FCOS <i>Prompt:</i> FCOS to show (? for help) = <i>Response:</i> The number of the FCOS you just added bits to or deleted bits from. If necessary, repeat the appropriate preceding step(s) to make corrections.</p> 6. After confirming that additions and/or deletions are correct, exit from the Feature Class of Service Menu to save additions and deletions. 	<p>Menu Map 11</p>

Verify Configuration Parameters

VoiceMemo Release 6.0A and later

This procedure describes how to verify the configuration parameters that have been entered. This procedure can be used for any of these applications:

- VoiceMemo
- DID VoiceMemo
- Paging
- Message delivery
- RS-232 Message Waiting Lights
- DTMF-to-PBX Message Waiting Lights
- Integrations and other optional features

<i>Step</i>	<i>Reference</i>
-------------	------------------

<p>☞ All Applications Except Paging and Message Delivery *</p> <ol style="list-style-type: none"> 1. Reach the Main Menu, then go to the Reports Menu. 2. Request a configuration report. <p><i>Select:</i> (C) Configuration <i>Prompt:</i> REPORT OUTPUT ROUTING</p> <p>(C) Console (screen) (P) Console with pause (1) Printer A (F) File... (A) Append to file... (X) Exit (no report)</p> <p>If you need help later, type ?.</p> <p>COMMAND (C/P/1/F/A/X):</p> <p><i>Response:</i> C to send the report to the console without pausing P to send the report to the console, pausing as the screen fills, 1 to send the report to printer A*, F to send the report to a file on the Series 6 server, A to append the report to an existing file on the Series 6 server, or X to exit report output options (no report).</p> <p>* You can have one or more serial ports on your server with different devices, depending on the configuration of your server.</p>	<p>Menu Map 9</p>
---	-------------------

<i>Step</i>	<i>Reference</i>
<p><i>Prompt:</i> Enter group number to display (1-24) or <CR> for all: <i>Response:</i> The number of the line group to which the application is assigned. Examples of valid formats for this response are:</p> <ul style="list-style-type: none">• 1 to report the configuration of line group 1• 1-4 to report the configuration of line groups 1 through 4• 1,2,4-7 to report the configuration of line groups 1, 2, and 4 through 7• Press Enter to get the configuration of all line groups <p>The server shows the name of the application assigned to each group specified and displays the parameter settings for that application.</p>	
<ol style="list-style-type: none">3. To make corrections, go to the appropriate application menu and enter the correct value.4. Save the corrections by exiting from the appropriate application menu.	Menu Maps
<p>☎ Paging and Message Delivery</p>	
<ul style="list-style-type: none">• If you are currently modifying the Pager or Message Delivery application, go to the Pagers Menu. <ol style="list-style-type: none">1. View the configuration.<p><i>Select:</i> (S) Show Pagers <i>Response:</i> The server displays the pager system number (index number), pager name, access code, and hold time for each pager.</p>2. Check the displayed configuration for each pager system against your Pager and Message Delivery Worksheet to verify that it is correct.3. To make corrections, return to the Pager Systems Supported option, the Define Pagers option, or the Other Features option then enter the correct values.4. When your entries are correct, save the parameter settings. <ul style="list-style-type: none">• If you are not currently modifying the Pager or Message Delivery application, proceed as for all applications described above.	Menu Map 7

Install Optional Feature With System Online

VoiceMemo Release 6.0A and later

The procedure describes how to install an optional feature with the system online. Be sure the Optional Feature Diskette(s) and the Module Enable Diskette contain the serial number(s) for all disk(s) in the system.

Note: The serial number on the OneView Optional Feature diskette must match the serial number of the hard disk on which OneView is being installed. If you receive an error message about an incorrect serial number, contact your support organization.

**CAUTION!**

If you are loading a revision support disk (RSD), do it after completion of this procedure. Loading the RSD first, could create an incorrect configuration.

*Step**Reference*

1. Reach the System Maintenance Menu, then go to the System Maintenance Additional Options Menu.
2. Select the Add Optional Feature(s) program.
 - Select:* (A) Add Optional Feature(s)
 - Prompt:* Enter 'Y' to add optional features, 'N' to stop:-
 - Response:* Y for Yes.
3. Install the optional feature.
 - Prompt:* Insert Optional Feature floppy disk in the floppy drive.
Enter any key when ready:
 - Response:* Insert the Optional Feature diskette, then press **Enter**.
4. After you have installed the Optional Feature software, the system asks if you want to install another optional feature.
 - Prompt:* Do you want to install another optional feature?
 - Response:* Y to install another optional feature and continue from step 3,
N if you are done installing optional features.

The system automatically edits and saves the configuration files, then returns to the Additional Options Menu.

5. Exit the VoiceMemo Configuration Offline Menu. You see the following prompt:
 - Prompt:* Wait for message waiting queues to be empty?
 - Response:* N to continue.

Menu Map 12

<i>Step</i>	<i>Reference</i>
<p>6. The following prompt appears: <i>Prompt:</i> Wait for paging queues to be empty? <i>Response:</i> N to continue.</p>	
<p>7. Exit to the VoiceMemo Configuration - Main Menu, then go to the VoiceMemo Configuration - Offline Menu.</p>	Menu Map 2
<p>8. Duplicate the active configuration. <i>Select:</i> (B) Duplicate Active Configuration</p>	
<p>9. Exit to the VoiceMemo Configuration - Main Menu and activate the configuration. <i>Select:</i> (A) Activate Configuration</p>	

Shut Down a System

VoiceMemo Release 6.0A and later

This procedure describes how to shut down a module or an entire Series 6 server. You should use this procedure before turning off the power to a module, as the shutdown command halts call processing in a clean and orderly fashion.

**WARNING!**

You should follow the policies of the site to warn users prior to the system shutdown. This process removes the system from call processing. Centigram recommends that you perform this procedure only during periods of low call traffic.

<i>Step</i>	<i>Reference</i>
<p>1. Reach the System Maintenance Menu.</p> <p>2. Execute a shutdown command.</p> <p style="padding-left: 2em;"><i>Select:</i> (S) System Shutdown</p> <ul style="list-style-type: none"> • The system displays the status of each line and the lengths of the message indicator request queues. <p style="padding-left: 2em;"><i>Prompt:</i> WARNING!! This will terminate call processing. Type "shutdown" if you really want to do this.</p> <p style="padding-left: 2em;"><i>Response:</i> shutdown</p> <p>3. If you have a multi-module system, specify which modules to shut down.</p> <p style="padding-left: 2em;"><i>Prompt:</i> modules to shutdown:</p> <p style="padding-left: 2em;"><i>Response:</i> a for all modules, or the number of a specific module (1, 2, 3, or 4). You can select multiple modules by entering the IDs separated by commas (3,4), or a range by using a hyphen (2-4).</p> <ul style="list-style-type: none"> • The system displays the status of each line of the specified modules as "idle," "active," or "stopped," and updates the status every minute until all lines are stopped. The system stops any calls still in progress after five minutes. <p>4. If you are executing a <i>system</i> shutdown, wait for the message waiting queue to clear. If you are executing a <i>module</i> shutdown on a multi-module system, do not wait for the message waiting queue to clear.</p> <p style="padding-left: 2em;"><i>Prompt:</i> Wait for message waiting queues to be empty?</p> <p style="padding-left: 2em;"><i>Response:</i> Y to wait for the queue to clear, N to continue immediately with the shutdown.</p> <p>5. When the system has taken all lines of the specified modules off-hook, it continues by asking if a verify is to be executed.</p> <p style="padding-left: 2em;"><i>Prompt:</i> Perform Offline System Verification? (Y/N):</p> <p style="padding-left: 2em;"><i>Response:</i> Y to execute the verify, N to skip verify and continue with the shutdown.</p>	Menu Map 1

<i>Step</i>	<i>Reference</i>
6. Specify if changes to the status of each module are to be made.	
<i>Prompt:</i> Enable or Disable Modules?	
<i>Response:</i> Y to change the status of modules, N to keep the module status the same and continue at step 11	
7. If you answered yes in step 6, a chart with the status of each module is displayed and then the Module Maintenance Menu is displayed.	
8. Enable a module, if necessary:	
<i>Select:</i> (E) ENABLE a module	
<i>Prompt:</i> Which Module?	
<i>Response:</i> The number of the module.	
9. Disable a module, if necessary:	
<i>Select:</i> (D) DISABLE a module	
<i>Prompt:</i> Which Module?	
<i>Response:</i> The number of the module. If you are disabling multiple modules, disable the module attached to the console last.	
<i>Prompt:</i> type "disable" to confirm your request:	
<i>Response:</i> disable	
If you are disabling multiple modules, repeat step 9. If the status of the module attached to the console was changed to disabled, the balance of this procedure is not seen, due to the module resetting. The console then resets to the Maintenance From Hard Disk Menu.	
10. When you are done configuring the modules, exit the menu.	
11. The system completes the shutdown.	
<i>Prompt:</i> ****SHUTDOWN COMPLETE****	
The System Maintenance Menu is displayed. You can now either reboot the module(s) or remove power to the module(s).	

Add FaxMemo to a Series 6 Server

VoiceMemo Release 6.0A and later

This procedure describes how to add FaxMemo capabilities to a Series 6 server. After completing this procedure, you must configure one or more of the FaxMemo applications.

Note: If your Series 6 server was configured with FaxMemo at the factory, the fax cards and fax software have already been installed.



WARNING!

This process requires the system to be shut down, resulting in loss of call processing capabilities. Centigram recommends that you perform this procedure during periods of low call traffic.

Note: You can find TRs referenced in this procedure in the *Centigram Series 6 Technical Reference Manual*.

<i>Step</i>	<i>Reference</i>
⌚ Before You Begin	
1. Complete a FaxMemo Card Planning Worksheet for each module and fax group in the system. Blank worksheets are located in Appendix A of this manual.	
2. Configure fax card jumpers. Pay special attention to the base I/O address.	TR 1904
⌚ Install the Fax Cards	
3. Perform a system shut down.	CP 5700
4. Turn off the power to the system.	
5. Install the fax cards.	CP 7510
6. Turn on the system power. Allow the system to boot from the hard disk.	
⌚ Install the FaxMemo Software	
7. Load the FaxMemo Optional Feature software.	CP 5402
8. Add the MVIP fax cards to the Resource Manager configuration.	TR 1935

Configure for Fax Mail

VoiceMemo Release 6.0A and later

This procedure summarizes the steps necessary to configure for Fax Mail in Series 6 server. It assumes that the appropriate server hardware and software have been installed.

<i>Step</i>	<i>Reference</i>
<p>1. Complete the following worksheets. Blank worksheets are near the back of this manual.</p> <ul style="list-style-type: none"> • FaxMemo Card Planning Worksheet • FaxMemo COS Planning Worksheet • Fax Mail Mailbox Worksheet(s) 	
<p>2. Create fax groups and assign them to the line groups that will be used for the fax^a application.</p> <p>Note: You should define the fax groups on the currently inactive configuration.</p> <p>If the line groups for the fax application do not already exist, refer to the <i>VoiceMemo Reference and Configuration Manual</i> for procedures to define inbound and outbound line groups.</p>	CP 7512
<p>3. Based on your completed FaxMemo COS Planning Worksheet, customize an FCOS (by either copying an existing FCOS and adding bits, or by modifying a current FCOS) to include bits listed below.</p> <p>Note: If you are providing users with broadcast mailboxes for fax reception, you must customize one FCOS for fax users and another FCOS for the broadcast mailboxes. If you offer different levels of service to users, you might have to customize more than one FCOS.</p> <ul style="list-style-type: none"> • To modify a current FCOS: • To copy a current FCOS and add additional bits: <ul style="list-style-type: none"> - 190 (receive fax messages) - 191 (make fax messages) - 192 (give fax messages) - 193 (deliver fax to default fax phone number) - 194 (deliver fax online) - 195 (deliver fax to designated telephone number) - 196 (user changeable default fax phone number for fax delivery) - 198 (receive fax messages only) - 199 (automatic receipt for fax message sent) 	<p>CP 5011</p> <p>CP 5007</p>

<i>Step</i>	<i>Reference</i>
<ul style="list-style-type: none"> - 200 (fax cover page) - 203 (walkaway fax) - 230 (deny change capabilities to cover page) - 235 (add "from" field to the default cover page) - 236 (add promotional message field to the default cover page) - 237 (automatic fax retrieval) - 238 (end of session delivery) - 239 (retrieve all unplayed faxes) - 240 (receive fax on record time-out) - 256 (enable fixed greeting for walkaway fax) 	
<p>4. Based on your completed FaxMemo COS Planning Worksheet, customize an LCOS with these limits parameters:</p> <ul style="list-style-type: none"> - Maximum number of digits allowable for fax phone number for fax delivery - Maximum number of fax messages per mailbox - CNG tone detection length (recommended value of zero) - Fax delivery retry frequency - Fax delivery retry interval - Played fax message retention - Unplayed fax message retention - Urgent fax message retention - Fax receipt retention 	CP 7508
<p>5. If you have MESA-Net installed on your server, reach the Network Class of Service Menu from the System Configuration Menu. If you do not have MESA-Net, go to step 7.</p>	Menu Map 13
<p>6. Based on your completed FaxMemo COS Planning Worksheet, customize an NCOS with these limits parameters:</p> <ul style="list-style-type: none"> - 10 (Make Fax Message to Network) - 11 (Give Fax Message to Network) - 12 (Answer Fax Message to Network) 	
<p>7. Based on your completed Fax Mail Mailbox Worksheets, configure user mailboxes for Fax Mail.</p>	CP 7506

<i>Step</i>	<i>Reference</i>
8. If some mailboxes use the default fax cover page and mailbox owners live in different time zones, configure time zones for FaxMemo.	CP 7509
9. If desired, set billing rates for FaxMemo. <ul style="list-style-type: none">• Set the rates for disk usage for fax messages.• Set the rates for messages received.	CP 4358, Ch 5 CP 4360, Ch 5
10. Verify that the configuration is correct.	CP 5015
11. Activate the configuration.	CP 7002

Configure for Fax Publishing

VoiceMemo Release 6.0A and later

This procedure summarizes the steps necessary to configure for Fax Publishing in a Series 6 server. It assumes that the appropriate server hardware and software have been installed.

Step	Reference
<p>1. Complete the following worksheets. Blank worksheets are near the back of this manual.</p> <ul style="list-style-type: none"> • FaxMemo Card Planning Worksheet • FaxMemo COS Planning Worksheet • Fax Publishing Mailbox Worksheet(s) <p>2. Create fax groups and assign them to the line groups that will be used for the fax application. You can probably use a shared fax group on an inbound line group to deposit faxes into the fax publishing system. You probably need a dedicated fax group for callers to retrieve faxes, either online or by entering a fax machine phone number.</p> <p>Note: You should define the fax groups on the currently inactive configuration.</p> <p>If the line groups for the fax application do not already exist, refer to the <i>VoiceMemo Reference and Configuration Manual</i> for procedures to define inbound and outbound line groups.</p>	CP 7512
<p>3. Based on your completed FaxMemo COS Planning Worksheet, customize an FCOS (by either copying an existing FCOS and adding bits, or by modifying a current FCOS) to include bits listed below.</p> <ul style="list-style-type: none"> • To modify a current FCOS: • To copy a current FCOS and add additional bits: <ul style="list-style-type: none"> - 194 (deliver fax online) - 195 (deliver fax to designated telephone number) - 197 (fax on demand) - 238 (end of session delivery) 	CP 5011 CP 5007
<p>4. Based on your completed FaxMemo COS Planning Worksheet, customize an LCOS with these limits parameters:</p> <ul style="list-style-type: none"> - Maximum number of digits allowable for fax phone number for fax delivery - Maximum number of fax messages per mailbox - CNG tone detection length (recommended value of zero) - Fax delivery retry frequency 	CP 7508

<i>Step</i>	<i>Reference</i>
<ul style="list-style-type: none"> - Fax delivery retry interval - Played fax message retention - Unplayed fax message retention - Urgent fax message retention - Fax receipt retention 	
<p>5. Based on your completed Fax Publishing Mailbox Worksheets, configure mailboxes for Fax Publishing.</p> <p>The kinds of mailboxes that can be used for Fax Publishing are:</p> <ul style="list-style-type: none"> • Tree • Chain • Greeting Only <p>Information for creating these special mailboxes can be found in the <i>VoiceMemo Reference and Configuration Manual</i>.</p>	CP 7506
<p>6. If some mailboxes use the default fax cover page and mailbox owners live in different time zones, configure time zones for FaxMemo.</p>	CP 7509
<p>7. If desired, set billing rates for FaxMemo.</p> <ul style="list-style-type: none"> • Set the rates for disk usage for fax messages. • Set the rates for messages received. 	CP 4358, Ch 5 CP 4360, Ch 5
<p>8. Verify that the configuration is correct.</p>	CP 5015
<p>9. Activate the configuration.</p>	CP 7002
<p>10. To deposit the faxes into the Fax Publishing mailboxes, you must call the server from a fax machine. Log into each Fax Publishing mailbox as the mailbox owner (by pressing <input type="button" value="*"/> before the mailbox number) and select <input type="button" value="TW 8"/> for user options, <input type="button" value="DEF 3"/> for fax options, and then press <input type="button" value="JKL 5"/> to leave a fax. When prompted, send the appropriate pages into the mailbox. Repeat for each mailbox in your Fax Publishing system.</p> <p>When a caller reaches one of the mailboxes, the server plays any recorded greeting in the mailbox and then tells the caller to get ready to receive the fax online or input a fax number to have the fax delivered.</p>	

Configure for Guaranteed Fax

VoiceMemo Release 6.0A and later

This procedure summarizes the steps necessary to configure for Guaranteed Fax in a Series 6 server. It assumes that the appropriate server hardware and software have been installed, and the hardware has been configured in the Resource Manager.

<i>Step</i>	<i>Reference</i>
<p>1. Complete the following worksheets. Blank worksheets are near the back of this manual.</p> <ul style="list-style-type: none"> • FaxMemo Card Planning Worksheet • FaxMemo COS Planning Worksheet • Guaranteed Fax Mailbox Worksheet(s) 	
<p>2. Create fax groups and assign them to the line groups that will be used for the fax application. You probably need a fax group dedicated to an inbound line group to provide guaranteed fax services.</p> <p>Note: You should define the fax groups on the currently inactive configuration.</p> <p>If the line groups for the fax application do not already exist, refer to the <i>VoiceMemo Reference and Configuration Manual</i> for procedures to define inbound and outbound line groups.</p>	CP 7512
<p>3. Based on your completed FaxMemo COS Planning Worksheet, customize an FCOS (by either copying an existing FCOS and adding bits, or by modifying a current FCOS) to include bits listed below.</p> <ul style="list-style-type: none"> • Modify an existing FCOS <p style="padding-left: 2em;">or</p> <ul style="list-style-type: none"> • Copy a current FCOS and add additional bits: <ul style="list-style-type: none"> - 198 (receive fax messages only) - 206 (fax delete) - 207 (fax verify) 	CP 5011
<p>4. Based on your completed FaxMemo COS Planning Worksheet, customize an LCOS with these limits parameters:</p> <ul style="list-style-type: none"> - Maximum number of fax messages per mailbox - CNG tone detection length (recommended value of zero) - Unplayed fax message retention - Urgent fax message retention 	CP 7508

<i>Step</i>	<i>Reference</i>
5. Based on your completed Guaranteed Fax Mailbox Worksheets, configure mailboxes for Guaranteed Fax. <ul style="list-style-type: none">• Enable message delivery.	CP 7506
6. If some mailboxes use the default fax cover page and mailbox owners live in different time zones, configure time zones for FaxMemo.	CP 7509
7. If desired, set billing rates for FaxMemo. <ul style="list-style-type: none">• Set the rates for disk usage for fax messages.• Set the rates for messages received.	CP 4358, Ch 5 CP 4360, Ch 5
8. Verify that the configuration is correct.	CP 5015
9. Activate the configuration.	CP 7002

Configure for Fax Broadcast

VoiceMemo Release 6.0A and later

This procedure summarizes the steps necessary to configure for Fax Broadcast in a Series 6 server. It assumes that the appropriate server hardware and software have been installed and the hardware has been added to the Resource Manager Configuration.

<i>Step</i>	<i>Reference</i>
<p>1. Complete the following worksheets. Blank worksheets are near the back of this manual.</p> <ul style="list-style-type: none"> • FaxMemo Card Planning Worksheet • FaxMemo COS Planning Worksheet • Fax Broadcast Mailbox Worksheet(s) <p>2. Create fax groups and assign them to the line groups that will be used for the fax application. You probably need at least one inbound and one outbound line group with fax resources.</p> <p>Note: You should define the fax groups on the currently inactive configuration.</p> <p>If the line groups for the fax application do not already exist, refer to the <i>VoiceMemo Reference and Configuration Manual</i> for procedures to define inbound and outbound line groups.</p> <p>3. Based on your completed FaxMemo COS Planning Worksheet, customize an FCOS (by either copying an existing FCOS and adding bits, or by modifying a current FCOS) to include bits listed below.</p> <ul style="list-style-type: none"> • To modify an existing FCOS or • To copy a current FCOS and add additional bits: <ul style="list-style-type: none"> - 122 (define broadcast mailbox) - 190 (receive fax messages) - 198 (receive fax messages only) - 203 (walkaway fax) <p>4. Based on your completed FaxMemo COS Planning Worksheet, customize an LCOS with these limits parameters:</p> <ul style="list-style-type: none"> - Maximum number of digits allowable for fax phone number for fax delivery - Maximum number of fax messages per mailbox - CNG tone detection length (recommended value of zero) - Fax delivery retry frequency - Fax delivery retry interval 	<p>CP 7512</p> <p>CP 5011</p> <p>CP 5007</p> <p>CP 7508</p>

<i>Step</i>	<i>Reference</i>
<ul style="list-style-type: none">- Played fax message retention- Unplayed fax message retention- Urgent fax message retention- Fax receipt retention	
5. Based on your completed Fax Broadcast Mailbox Worksheets, configure mailboxes for Fax Broadcast.	CP 7506
6. If some mailboxes use the default fax cover page and mailbox owners live in different time zones, configure time zones for FaxMemo.	CP 7509
7. If desired, set billing rates for FaxMemo. <ul style="list-style-type: none">• Set the rates for disk usage for fax messages.• Set the rates for messages received.	CP 4358, Ch 5 CP 4360, Ch 5
8. Verify that the configuration is correct.	CP 5015
9. Activate the configuration.	CP 7002
10. For each Fax Broadcast mailbox create distribution list 1 containing the recipients for faxes sent to that mailbox. Recipients can include local mailboxes, remote mailboxes on other Series 6 servers connected by a MESA-Net network, or outdial telephone numbers.	

Set Up a Company Fax Cover Page

VoiceMemo Release 6.0A and later

This procedure summarizes the steps necessary to set up a company fax cover page. It assumes that the appropriate server hardware and software have been installed. You can have a different fax cover page for each line group by assigning a unique administrator's mailbox to each line group and storing a different cover page in each administrator's mailbox.

Note: If you enter a company fax cover page, it takes precedence over the default cover page and does not include the dynamic information provided on the default cover page.

<i>Step</i>	<i>Reference</i>
<ol style="list-style-type: none">1. Plan the layout of the cover page on an 8.5 by 11-inch page. Be sure to include:<ul style="list-style-type: none">• Company name• Address• Telephone number• Fax number.2. Make sure that the administrator's mailbox has an FCOS with the bit 200 (fax cover page) enabled.3. Dial into the system administrator's mailbox from a fax phone and reach the User Options Menu. Press DEF 3 for Fax Delivery Options, then ABC 2 for Fax Cover Page. When prompted, fax the cover page into the mailbox.	

Activate the Inactive Configuration

VoiceMemo Release 6.0A and later

This procedure describes how to activate a configuration.



WARNING!

This procedure causes the server to restart all tasks resulting in an interruption to call processing. Centigram recommends that you perform this procedure during periods of low call traffic.

<i>Step</i>	<i>Reference</i>
<ol style="list-style-type: none"> 1. Reach the VoiceMemo Configuration Main Menu, then go to the VoiceMemo Active Configuration Menu. 2. Activate the inactive configuration. <ul style="list-style-type: none"> <i>Select:</i> (A) Activate Configuration <i>Prompt:</i> Activate the inactive configuration, <configuration name>: <i>Response:</i> Y to activate the configuration, or N to cancel the process. <i>Prompt:</i> Wait for message waiting queues to be empty? <i>Response:</i> Y to warn system users of the impending shutdown, or N to skip the warning. The server automatically shuts down and resets the software to the new configuration, then returns to the VoiceMemo Active Configuration Menu. • If the server experiences problems with the new configuration, you can return to the old configuration by repeating the preceding steps. 	Menu Map 2

Configure a Mailbox for FaxMemo

VoiceMemo Release 6.0A and later

This procedure describes how to configure those parameters in a mailbox setup that affect FaxMemo.

Step	Reference
<ol style="list-style-type: none"> 1. Reach the Mailbox Maintenance Menu. Enter the requested information, as described in the following steps, from your completed FaxMemo Mailbox Worksheet(s). 2. Identify the mailbox to be created or modified. <p><i>Select:</i> (C) Create New Mailboxes <i>Prompt:</i> Mailbox to create: <i>Response:</i> Number of the new mailbox you want to configure for paging.</p> <p>or</p> <p><i>Select:</i> (M) Modify Mailboxes <i>Prompt:</i> Mailbox to modify: <i>Response:</i> Number of the existing mailbox you want to reconfigure for paging.</p> <p>Note: The prompts are almost the same for creating a new mailbox and modifying an existing one, except that "New" precedes each prompt when you select Modify Mailboxes.</p> 3. Press Enter until the Features Class of Service prompt appears. 4. Assign an FCOS customized for the FaxMemo applications that the mailbox uses. <p><i>Prompt:</i> Features class of service: <i>Response:</i> The number of the FCOS (1-640) that includes the applicable bits.</p> 5. Assign the appropriately customized LCOS to the mailbox. <p><i>Prompt:</i> Limits class of service: <i>Response:</i> The number of the LCOS (1-640) that includes the applicable limits.</p> 6. Assign the appropriately customized RCOS to the mailbox. <p><i>Prompt:</i> Restriction class of service: <i>Response:</i> The number of the RCOS (1-64) that includes the applicable limits.</p> 7. If you have MESA-Net, assign the appropriately customized NCOS to the mailbox. <p><i>Prompt:</i> Network class of service: <i>Response:</i> The number of the NCOS (1-64) that includes the applicable limits.</p> 8. For Guaranteed Fax, set up message delivery to the target fax machine. If this mailbox is not used for Guaranteed Fax, skip to step 11. <p><i>Prompt:</i> Message Waiting Type #1: or Message Waiting Type #2: <i>Response:</i> 5</p> 	<p>Menu Map 3</p>

Step *Reference*

Prompt: Pager access type:

Response: The **letter** of the index to be used for delivery to a fax machine. The valid choices are:

- I Internal outcall index
- B Billed outcall index
- U Non-billed outcall index
- N Undefined index

Prompt: Pager number:

Response: The **phone number** of the target fax machine.

Prompt: Post-pager number:

Response: Leave blank if desired, or enter any overflow from the pager number that did not fit in the page number field.

Note: There is no need to set the pager frequency or pager interval for Guaranteed Fax; those functions are controlled by LCOS settings.

9. For Guaranteed Fax, activate message delivery.

Prompt: Message delivery:

Response: Y

10. For Guaranteed Fax, schedule fax delivery.

Prompt: Pager start time

Response: The **time** at which fax delivery is to start. Enter the time in hours and minutes followed by "am" or "pm," for example 6:00pm. To have fax delivery enabled for all times, set both Pager start time and Pager stop time to the same value, such as 12:00am.

Prompt: Pager stop time

Response: The **time** at which fax delivery is to stop. Enter the time in hours and minutes followed by "am" or "pm," for example 6:00pm. To have fax delivery enabled for all times, set both Pager start time and Pager stop time to the same value, such as 12:00am.

11. Specify the fax retrieval access type.

Prompt: Fax retrieval pager access type:

Response: The **letter** of the index to be used for fax retrieval. The valid choices are:

- I Internal outcall index
- B Billed outcall index
- U Non-billed outcall index
- N Undefined index

<i>Step</i>	<i>Reference</i>
<p>12. Specify the default fax phone number. This number is not used by Guaranteed Fax.</p> <p><i>Prompt:</i> Default telephone number for fax retrieval: <i>Response:</i> The default number (1-16 characters) of the fax phone the fax message is to be delivered to. This field can contain any additional characters necessary for outdialing, from Table 1 at the end of this procedure.</p> <p>13. Specify the time zone offset for the mailbox.</p> <p><i>Prompt:</i> Time zone offset: <i>Response:</i> The number of hours difference between the time zone of the mailbox owner and the local time zone of the Series 6 server. Valid values are + from -23 to +23. This number must match the offset of one of the time zones set in the Time Zone Configuration Menu.</p> <p>14. Press Enter to skip through each of the remaining mailbox configuration prompts. After the last prompt, the system displays the mailbox configuration, then prompts for the next mailbox number.</p> <p>At this point, the parameter settings are saved and you can continue with mailbox configuration or exit.</p>	

Step

Reference

Table 1 Dial String Characters

Character	Explanation
0-9, *, #	Keys on a standard pushbutton telephone
(The following digits should be dial pulsed (10 PPS)
)	Stop pulsing; resume sending DTMF tones
+	Pause for one second
A-D	Fourth column DTMF keys
E	Go off-hook, wait for dial tone or other steady tone (pager go-ahead or confirmation tone, for example), then do next item in string
F	Switchhook flash and wait for dial tone
G	Greet - Wait for a voice or computer tone answer
H	Hang up (go on-hook)
L	Wait for an answer supervision signal that indicates the receiving phone has gone off-hook, then dial remaining characters after receiving the signal. Valid only with four-wire connections, not with loop start or ground start phone lines.
N	Start a new activity; do not go off-hook
O	Ring once
P	Go off-hook, do not wait for dial tone
S	Switchhook flash, no wait required
T	Go off-hook, wait for dial tone
V	Play three seconds of the message for voice pager

Set Limits for FaxMemo

VoiceMemo Release 6.0A and later

This procedure describes how to set the limits that govern FaxMemo.

Step	Reference
<p>1. Reach the System Configuration Menu, then go to the Limits Class of Service Menu.</p> <p>2. Identify the LCOS you want to modify.</p> <p><i>Select:</i> (C) Choose Limits COS to Modify <i>Prompt:</i> Enter limits COS to modify <i>Response:</i> Number of the LCOS you want to modify limits in, or just press Enter if the displayed LCOS is the one you want.</p> <p><i>Select:</i> (N) Name Selected LCOS <i>Prompt:</i> Enter name for selected limits COS <i>Response:</i> A descriptive name for the LCOS, from 1 through 15 characters; or just press Enter if the displayed LCOS name is the one you want.</p>	Menu Map 11
<p>☎ Set CNG Tone Detection Length (Walkaway Fax only)</p>	
<p>3. Go to the FaxMemo Limits Menu.</p> <p>4. Set the length of time that the Series 6 server waits for CNG tone.</p> <p><i>Select:</i> (C) CNG Tone Detection Length <i>Prompt:</i> Enter CNG tone detection length in seconds <i>Response:</i> The number of seconds (4-60) the server must detect the CNG tone. For all sites except those with extremely noisy phone circuits, set this to zero to disable forced detection and enable automatic detection.</p>	Menu Map 11
<p>☎ Set Fax Delivery Limits</p>	
<p>5. Go to the FaxMemo Limits Menu.</p> <p>6. Set the maximum phone number length for delivering fax messages.</p> <p><i>Select:</i> (A) Maximum Number of Digits for Telephone Number <i>Prompt:</i> Enter maximum phone number length for fax delivery <i>Response:</i> The maximum number of digits (1-24) allowed in the fax phone number for fax delivery.</p> <p>7. Set the number of times the server attempts to deliver a fax.</p> <p><i>Select:</i> (D) Fax Delivery Retry Frequency <i>Prompt:</i> Enter number of retries for fax delivery <i>Response:</i> The number of retry attempts (0-255) the server makes to deliver a fax.</p> <p>8. Set the number of minutes between fax delivery retries.</p> <p><i>Select:</i> (E) Fax Delivery Retry Interval <i>Prompt:</i> Enter number of minutes between fax delivery retries <i>Response:</i> The number of minutes (0-255) the server waits between between fax delivery retries.</p>	Menu Map 11

<i>Step</i>	<i>Reference</i>
<p>☛ Set Fax Storage Limits</p> <p>9. Go to the FaxMemo Limits Menu.</p> <p>10. Set the maximum number of faxes allowed to be stored in a mailbox.</p> <p><i>Select:</i> (B) FaxMemo Message Count <i>Prompt:</i> Enter maximum number of fax messages allowed <i>Response:</i> The maximum number of faxes (0-73) allowed or 0 (zero) or a period (.) to allow an unlimited number of faxes to be stored.</p> <p>11. Go to the Message Retention Limits Menu.</p> <p>12. Set the number of hours the server retains played fax messages.</p> <p><i>Select:</i> (A) Played Fax Message Retention <i>Prompt:</i> Enter hours to keep played fax messages <i>Response:</i> The number of hours (0-8760) a played fax message is kept, if not deleted by the user.</p> <p>13. Set the number of hours the server retains unplayed fax messages.</p> <p><i>Select:</i> (B) Unplayed Fax Message Retention <i>Prompt:</i> Enter hours to keep unplayed fax messages <i>Response:</i> The number of hours (0-8760) a unplayed fax message is kept.</p> <p>14. Set the number of hours the server retains urgent fax messages.</p> <p><i>Select:</i> (C) Urgent Fax Message Retention <i>Prompt:</i> Enter hours to keep urgent fax messages <i>Response:</i> The number of hours (0-8760) a urgent fax message is kept.</p> <p>15. Set the number of hours the server retains fax receipts.</p> <p><i>Select:</i> (D) Fax Receipt Retention <i>Prompt:</i> Enter hours to keep receipts <i>Response:</i> The number of hours (0-8760) a fax receipt is kept, if not deleted by the user.</p> <p>16. Save the modified limits by exiting to the System Configuration Menu.</p>	<p>Menu Map 11</p> <p>Menu Map 11</p>

Configure Time Zones for FaxMemo

VoiceMemo Release 6.0A and later

This procedure describes how to configure time zones so that the correct time stamp appears on the default cover page of outgoing faxes.

Note: The server does not put a time stamp on company cover pages or personal cover pages. If your FaxMemo applications do not use default cover pages, you do not need to configure time zones.

<i>Step</i>	<i>Reference</i>
<p>1. Reach the Time Zone Configuration Menu from the System Maintenance – Additional Options Menu.</p> <p>2. Identify the time zone that you want to configure.</p> <p><i>Select:</i> (A) Current time zone</p> <p><i>Prompt:</i> Enter timezone number to modify:</p> <p><i>Response:</i> The number (1-26) of the time zone that you want to configure.</p> <p>Note: Time zone 1 is automatically used as the local time zone for the Series 6 server. Be sure to configure a name for time zone 1, but do not configure an offset.</p> <p>3. Set the number of hours difference (offset) from the local time zone of the Series 6 server.</p> <p>Note: Each mailbox also has a Time Zone Offset parameter. When sending a fax from a mailbox that uses a default cover page, the server looks for a time zone configured here that matches the offset in the mailbox. The server prints the name of the matching time zone on the default cover page.</p> <p><i>Select:</i> (B) Set current time zone offset</p> <p><i>Prompt:</i> Enter time zone offset (3 char):</p> <p><i>Response:</i> The number of hours difference between the time zone of the Series 6 server and the time zone of the mailbox owner. Valid values are -23 to +23.</p> <p>4. Enter a name for the time zone.</p> <p><i>Select:</i> (C) Name time zone</p> <p><i>Prompt:</i> Enter time zone name:</p> <p><i>Response:</i> A name (up to 35 characters) that identifies the time zone. You can use the full time zone name, such as Pacific Standard Time, or an abbreviation, such as PST.</p> <p>5. Repeat steps 2 through 4 until you have set values for all time zones used by mailbox owners.</p>	Menu Map 12

<i>Step</i>	<i>Reference</i>
<p>6. Verify the settings that you have made.</p> <p><i>Select:</i> (D) Display zone name <i>Prompt:</i> Display Time Zone ----- (A) Show a time zone (B) Show all time zones (X) Exit</p> <p><i>Response:</i> B to see a table of all 26 time zones, or A to see the configuration of one specific time zone.</p> <p>7. When you are satisfied with the time zone settings, exit to the System Maintenance Menu.</p>	

Define a Fax Group

VoiceMemo Release 6.0A and later

This procedure describes how to define a fax group and connect it with line groups. It assumes that you have already added the line cards and fax cards to the Resource Manager configuration.

Step

Reference

1. Reach the VoiceMemo Configuration Offline Menu, then go to the Fax Group Menu.

Menu Map 13

Enter the requested information, as described in the following steps, from your completed FaxMemo Card Planning Worksheet.

2. If desired, use the menu options to show all defined fax groups and/or show unassigned fax channels.
3. Specify the fax group number that you want to define.

Select: (G) Current Fax Group

Prompt: Enter a group number =

Response: **Number** of the fax group (1-42) to that you are defining.

4. Identify the module for the fax group.

Select: (M) Module of Current Fax Group

Prompt: Enter module number =

Response: **Number** of the module (1-4) that contains the fax cards that you want included in the fax group.

5. Add the desired fax channels.

Select: (B) Add Channels to Current Fax Group

Prompt: Enter fax channels to add =

Response: The **fax card slot number** (0-15) and **channel number** (0-8) that you want to add to the fax group. Separate the two numbers with a colon (:).

Any of the formats shown in the following examples are valid:

<i>Example</i>	<i>Specifies</i>
*	All channels in the given module
10:*	All channels on the fax card in slot 10
8-10	All channels on fax cards 8 through 10
9:0-10:2	All channels on the card in slot 9 through channel 2 on the card in slot 10
7:0,8:1,9:*	Slot 7 channel 0, slot 8 channel 1, and all channels on the fax card in slot 9

Depending on the Series 6 server model that you have, your server may have fewer than 15 slots and fewer the 8 channels on a fax card.

<i>Step</i>	<i>Reference</i>
<p>6. Drop any desired fax channels.</p> <p><i>Select:</i> (D) Drop Channels from Current Fax Group</p> <p><i>Prompt:</i> Enter fax channels to drop =</p> <p><i>Response:</i> Channels(s) to remove from the current fax group; values and formats are the same as described above for adding channels.</p>	
<p>7. Repeat steps 2 through 6 for each fax group that you want to define. Note that if you have line groups that have cards in more than one module and you want to give those line groups fax capability, you must define a fax group for each module.</p>	
<p>8. Exit from the Fax Group Menu back to the Line Groups Menu.</p>	
<p>9. Select a line group that you want to associate (connect) with one or more fax groups.</p> <p><i>Select:</i> (G) Current Group</p> <p><i>Prompt:</i> Enter a group number =</p> <p><i>Response:</i> Number of the line group (1-42) to that you want to connect with fax groups.</p>	
<p>10. Identify the fax group(s) to associate with the line group.</p> <p><i>Select:</i> (C) Fax group connections for current line group</p> <p><i>Prompt:</i> Line group <i>x</i>, Module <i>y</i>: (where <i>x</i> is the line group that you selected in step 9, and <i>y</i> is the first number of the first module that has voice ports in line group <i>x</i>.)</p> <p><i>Response:</i> Number of the fax group (1-42) to that you want to connect with the line group. You can connect a fax group with more than one line group.</p> <p>The system requests a fax group number for every module that has voice ports in the line group.</p>	
<p>11. Repeat steps 9 through 10 for each line group that you want to associate with fax groups.</p>	
<p>12. Exit to the VoiceMemo Configuration Offline Menu, saving the changes.</p>	

4 Software Configuration Planning

This chapter is designed to help you plan the changes that you must make to your software configuration when you add FaxMemo applications to your Series 6 server. It describes all of the software options for FaxMemo, and explains how they are used in the various applications.

Planning Your FaxMemo Configuration

Before you can configure any FaxMemo applications, you must first assign fax groups to any line groups that will carry fax traffic. You can then plan and configure the applications you choose to enable, including any of the following tasks:

- Assign fax options to existing classes of service (COSs)
- Update current mailboxes and create fax broadcast mailboxes (if required) for each new FaxMemo user
- Create Fax Publishing mailbox trees and/or chains
- Create and configure Guaranteed Fax mailboxes
- Create master fax distribution (broadcast) lists
- Create and store a company fax cover page

Each of these tasks is covered in detail under the application name.

Offline Configuration

After you install the FaxMemo cards but before you assign fax features to COSs, you must create fax groups and then associate (connect) the fax groups with line groups. The FaxMemo Card Planning Worksheet from the previous chapter has spaces for the information that you need. Use the most recent Configuration Report to determine which line groups to connect with fax groups.

FaxMemo Classes of Service (COSs)

The system administration menus contain FaxMemo configuration parameters for feature, limit, and network classes of service (FCOS, LCOS, and NCOS). All of

these options are described below. Read through their descriptions before completing the remaining worksheets. Some of the options are similar to those for voice messaging, but some are unique to fax handling. When you assign a FaxMemo feature to a mailbox, the appropriate user and outside caller prompts are enabled automatically. The voice prompts are described in the *User Guide for VoiceMemo and FaxMemo*.

Fax Features

The feature bits described below are included with FaxMemo.

190 Receive fax messages (master feature)

This feature allows a mailbox to receive fax messages. When callers reach the mailbox, they are first prompted to leave a voice message, then prompted to press **L** to leave a fax with the voice message. Callers can ignore the message prompt and press **L** to leave a fax without a voice coversheet. When the user accesses the mailbox, the user is informed that there is a message with a fax there and given options to retrieve the fax online or direct the fax to a fax machine after hearing the voice message.

Note: The mailboxes must also include one or more of the fax delivery features (193, 194, 195, 237) to permit the users to retrieve faxes stored in the mailboxes.

If feature bit 240 is enabled, callers do not need to press **L** to begin sending a fax; the system will detect an incoming fax when it does not hear speech.

191 Make fax messages

When this feature is assigned to a mailbox, the mailbox owner can make a voice message, and then press **L** to leave a fax with the message. The fax is then delivered to the addressed party or parties with the voice message.

192 Give fax messages

This FaxMemo feature allows users who are able to receive faxes in their mailboxes to forward the faxes along with voice comments directly to other users or to outside lines. They cannot include another fax as a comment.

Note: This feature requires feature bit 190.

193 Deliver fax to default fax phone number

This feature allows a user to have faxes delivered to a personal (default) fax telephone number after listening to the voice annotation. This number can be a department or company fax machine and is entered by the system administrator during configuration. When the user selects this option, another menu is played giving further options to schedule delivery, cancel delivery, or deliver the fax now.

Note: This feature requires bit 190. The system must have a fax group connected to an outbound line group to deliver faxes to phone numbers.

194 Deliver fax online

This feature permits users accessing their mailboxes from a fax phone to receive stored faxes online.

Note: This feature requires feature bit 190. The system must have a fax group connected to an inbound line group to deliver faxes online.

195 Deliver fax to designated telephone number

When this feature is included in a mailbox and the user wishes to retrieve a fax or deliver it to someone else after listening to the voice annotation, the prompt

Press I to input a number for this fax

is included in the fax transmittal options menu. After the user selects I and inputs the number, another menu is played giving the choices of scheduling the delivery, canceling it, or having the fax delivered now.

Note: This feature requires bit 190 for fax functionality and bit 95 to schedule fax delivery. The system must have a fax group connected to an outbound line group to deliver faxes to phone numbers. Additionally, a "fax pager index" must be set in the user's mailbox.

196 User changeable default fax phone number for fax delivery

This feature allows users to change their personal (default) fax delivery numbers through the user options menu in their mailboxes.

Note: This feature requires bit 193.

197 Fax on demand

This feature is for Fax Publishing. When it is assigned to a greeting only mailbox, the caller is greeted and given a prompt to get ready to receive the fax deposited in the mailbox, either online or at another number. The mailbox LCOS and RCOS control the delivery features.

Note: This feature requires feature bit 194 and/or 195.

198 Receive fax messages only

This feature prevents a mailbox from receiving voice messages and allows it to receive only fax messages. It is used for both Guaranteed Fax and broadcast mailboxes in Fax Mail. No greeting or prompts are played to the calling party and only faxes are recorded. A fax session starts immediately when the server answers the call.

A Guaranteed Fax mailbox must have both this bit and message delivery enabled.

Note: This feature requires feature bit 190.

199 Automatic receipt for fax message sent

When this feature is included in a mailbox and the user schedules a fax delivery, a receipt with a time stamp is automatically placed in the sending user's mailbox.

200 Fax cover page

This feature causes the system to send a cover page with outgoing faxes. The cover page identifies the user as the fax recipient at the company or department fax machine. Mailbox owners can fax a personal cover page into their mailboxes which the system sends each time they retrieve faxes. When a cover page is deposited in the system administrator's mailbox, it becomes the company fax cover page and it is delivered with faxes retrieved by users who do not have a personal cover page. If neither a personal cover page nor a company cover page is available, the system generates a default cover page.

If this bit is not enabled in an FCOS, the system does not send any cover sheet with outgoing faxes.

Note: Feature bit 230 disables the mailbox personal fax cover page option so that mailbox owners cannot override the company or default cover page.

203 Walkaway fax

A mailbox with this feature is set to expect calls from fax machines rather than from live callers. When a call is routed to a mailbox with this feature, CNG detection is enabled while the mailbox greeting is playing. If the system detects fax tone, it processes the incoming fax. If it does not detect fax tone, it plays the recorded mailbox greeting and prompts. This permits callers to dial into a user's mailbox and immediately send a fax without a voice coversheet, and without having to respond to prompts or monitor the call.

Feature bit 256 causes the system to play a brief introductory prompt for walkaway fax mailboxes.

Note: When feature bit 203 is active, the system listens for fax tone (CNG) in order to act like a receiving fax machine when the call is initiated by a sending fax machine.

When feature bit 240 is active, the system always defaults to accepting a fax when it does not detect voice. This is similar to the function of bit 203. However, callers will hear fax signals if their voice recording times out.

This feature requires feature bit 190.

206 Fax delete

This feature automatically deletes a fax from a mailbox after it has been delivered. It is used in Guaranteed Fax to prevent resending the same message to the fax machine.

Note: Feature bit 237 (Automatically deliver fax to default number) overrides this feature. 237 is for user mailboxes, not guaranteed fax mailboxes. Do not use both bits in the same FCOS.

207 Fax verify

This feature is assigned to Guaranteed Fax mailboxes which are on the same hunt group as the fax machines. It checks incoming faxes with those already stored in the mailbox to prevent the same fax from rotating through the hunt group and getting stored in the mailbox again when the fax machine is down or busy.

230 Deny change to fax cover page

This feature disables a mailbox owner's ability to create a personal fax cover page. If feature bit 200 is enabled, the system will send either a company cover page (if one has been placed in the administrator's mailbox) or the system default cover page. This feature has no effect if bit 200 is not enabled.

235 Display from field on fax cover page

This feature adds the “From” field to the default fax cover page. The field identifies the *system* that the fax came from, such as, “ABC Communications Fax Service.” It does not identify the mailbox owner. The text of the “From” field is set in the Fax Service and Promotional Message Menu.

236 Display promotional field on fax cover page

This feature adds a promotional message field to the default fax cover page. The text of the promotional message field is set in the Fax Service and Promotional Message Menu.

237 Automatic fax retrieval

This feature allows the mailbox owner to have faxes downloaded automatically to a preconfigured default fax number when faxes arrive in the mailbox. The fax or voice/fax message is automatically moved to the saved queue and the message waiting indicator is not triggered. This feature is intended to make it easier for mailbox owners who regularly use the same fax machine to retrieve their faxes. The mailbox owner can also enable or disable this feature from the user options menu.

Note: When this feature is active, the mailbox owner should check the target fax machine frequently, since fax messages will not activate a message waiting indicator.

This feature overrides feature bit 206 (Discard fax message after delivery). 206 is for guaranteed fax mailboxes only. Do not include both bits in the same FCOS.

238 End of session delivery

This feature is invisible to users. However, it allows the system administrator to save on outbound fax calls. Instead of making an outbound call for each fax, this feature enables the system to make only one outbound call for all faxes sent to the same number during a mailbox session.

Note: This feature requires feature bit 193 and /or 195.

239 Retrieve all unplayed faxes

This feature makes it easier for mailbox owners to get their faxes. If they do not have automatic fax delivery enabled, they have the option to have all faxes concatenated and sent at once. The user selects the “retrieve all faxes” option from the user options menu and all the faxes are automatically sent to the user’s default fax number.

Note: This feature requires one or more of feature bit 193, 194, or 195.

240 Receive fax on record time-out

This feature makes it easier for callers to send fax-only messages and voice/fax messages. In the case of fax-only messages, a caller can dial into a mailbox, press start, and walk away. In the case of the voice/fax message, the caller does not need to press **L** to send the fax.

Note: When feature bit 203 is active, the system listens for fax tone (CNG) in order to act like a receiving fax machine when the call is initiated by a sending fax machine. Without bit 203, callers to a mailbox must press **L** to indicate that they want to leave a fax.

When feature bit 240 is active, the system always defaults to accepting a fax when it does not detect voice. This is similar to the function of bit 203, except that the user does not have to press **L** to leave a fax. However, callers will hear fax signals if their voice recording times out.

This feature requires feature bit 190.

256 Enable fixed greeting for walkaway fax

The feature bit causes walkaway fax mailboxes to play the prompt, “Press 1 or wait...” before playing the mailbox greeting.

Fax Limits

The following fax limits can be included in limits classes of service (LCOS).

Number of digits for fax phone number for fax delivery

This limit restricts the user to the set number of dialing digits when retrieving or redirecting a fax to a designated number. For example, 3 or 4 digits would only allow faxes to be redirected to an internal extension, but 11 digits would let the user send faxes long distance. If no digits are specified, then the number of digits defaults to that entered for the outside caller dialing plan at the Online Configuration Menu.

Note: This limit works in conjunction with RCOS NPA/NXX screening.

Number of fax messages per mailbox

This limit is the maximum number of faxes that can be stored in a mailbox at any one time.

CNG tone detection length

This limit is the number of seconds that the Series 6 server waits to detect the CNG tone from a calling fax machine when walkaway fax is enabled (feature bit 203). This limit should be set to zero except for sites with very noisy phone circuits.

Fax delivery retry frequency

This limit is the number of times the server attempts to send a fax message until it is successfully sent. The system retries fax delivery when it encounters ring no answer, busy, or no available fax resource.

Fax delivery retry interval

This limit is the number of minutes the system waits between retries on delivering a fax message.

Played fax message retention

This limit is the maximum number of hours that played faxes can be stored in a mailbox.

Unplayed fax message retention

This limit is the maximum number of hours that unplayed faxes can be stored in a mailbox.

Urgent fax message retention

This limit is the maximum number of hours that urgent faxes can be stored in a mailbox.

Fax receipt retention

This limit is the maximum number of hours that fax receipts can be stored in a mailbox.

Fax Networking Features

The following options determine a user's fax capability over a MESA-Net network to other Series 6 servers. These are entered as part of the network class of service (NCOS).

10 Make fax messages to the network

This feature allows a user to make a fax message and send it over the network.

11 Give fax messages to the network

This feature permits users to forward fax messages deposited in their mailboxes to users on another system over the network. It does not allow users to make a fax message to the network.

12 Answer fax messages to the network

A user with this feature can reply to a fax message that was sent from another system over the network. If feature bit 38 is activated, the original message, voice and fax, will be sent with the reply back across the network.

FaxMemo and RCOS

Like all other types of outbound calls, outbound FaxMemo calls are controlled by the Restriction Class of Service of the sending mailbox. A mailbox owner cannot have a fax delivered to a phone number that is blocked in their RCOS.

Adding FaxMemo Options to COSs

Add FaxMemo options to mailboxes exactly as you would voice message options. You can include them in existing or new FCOSs, LCOSs, and NCOSs. You must generate new COSs for applications peculiar to FaxMemo, such as guaranteed fax and fax publishing.

These are some fax mail FCOS options:

- VIP FCOS + 190-196 and 200
User can receive and send fax messages and include a cover sheet. Callers must use the phone keypad to send a fax.
- VIP FCOS + 190-196, 200, and 203
Same as above, but callers can also send walkaway fax messages.
- VIP FCOS + 198 and 200

Fax only mailbox. This receives fax messages with no voice annotation and supports a cover page. Use bits 193-195 to retrieve messages.

A sample FaxMemo COS Planning Worksheet follows this section. Blank worksheets are in Appendix A for photocopying. The Fax FCOS and NCOS bits and names are included at the top of the worksheet for your reference.

If you add fax features to an existing COS without renumbering the COS, the existing mailboxes with that COS assigned take on the added fax features. If you create a new COS by copying an existing one and modifying it, you must assign the new COS to mailboxes (see "FaxMemo Mailboxes").

Note that there are entries for users' standard mailboxes and users' broadcast fax mailboxes. If a user is likely to receive many fax calls, he or she should probably have a separate extension for faxes that has an associated broadcast mailbox. The broadcast mailbox contains a distribution list consisting of only the user's standard VoiceMemo mailbox. Messages or faxes left in the broadcast mailbox are immediately transferred to the user's standard mailbox, as shown in Figure 4-1.

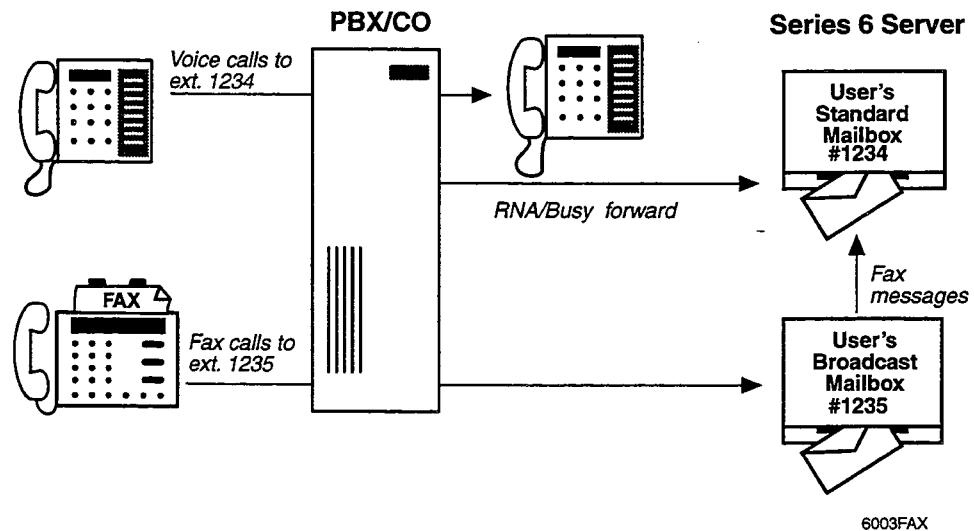

Figure 4-1 Broadcast Mailbox Fax Mail Application

FaxMemo COS Planning Worksheet

Fax Feature Bits

Number	Description
190	Receive Fax Messages
191	Make Fax Messages
192	Give Fax Messages
193	Deliver Fax to Default Fax Phone Number
194	Deliver Fax Online
195	Deliver Fax to Designated Phone Number
196	User Changeable Default Fax Phone Number for Fax Delivery
197	Fax on Demand
198	Receive Fax Messages Only
199	Automatic Receipt for Fax Sent
200	Personal Fax Cover Page
203	Walkaway Fax
206	Fax Delete

Fax Feature Bits (continued)

207	Fax Verify
230	Deny Changes to Fax Cover Page Options
235	Add "From" Field on Fax Cover Page
236	Add "Promotional" Field on Fax Cover Page
237	Automatic Fax Retrieval
238	End of Session Delivery
239	Retrieve All Unplayed Faxes
240	Receive Fax on Record Time-Out
256	Enable Fixed Greeting for Walkaway Fax

Fax NCOS Bits

Number	Description
10	Make Fax Message to Network
11	Give Fax Message to Network
12	Answer Fax Message to Network

COSs for User's Normal Mailbox

FCOS # to Modify	New FCOS Number	New FCOS Name	FAX Feature Bits to Add
10	22	VIP Fax	190, 196, 200, 203

LCOS Number	Number of Digits for Fax Delivery	# Fax Msgs per Mailbox	Fax Delivery Retry Frequency	Fax Delivery Retry Interval	CNG Tone Detection Length	Played Fax Msg Retention	Unplayed Fax Msg Retention	Urgent Fax Msg Retention	Fax Receipt Retention
1	11	5	5	2	0	336	168	72	72

NCOS # to Modify	New NCOS Number	New NCOS Name	FAX NCOS Bits to Add
1	1	Network Fax	10, 11, 12

FCOS for User's Fax Broadcast Mailbox

FCOS # to Modify	New FCOS Number	New FCOS Name	FAX Feature Bits to Add

Prepared By: _____ Date: _____

Configured By: _____ Date: _____

FaxMemo Mailboxes

The planning and configuration for mailboxes for each FaxMemo application is slightly different. This section contains information about mailboxes for each application, and sample worksheets to help in planning.

Note: You can add Walkaway Fax to any of the other FaxMemo applications by enabling the appropriate feature bits in an FCOS.

Fax Mail Mailbox Configuration

The Fax Mail Mailbox Worksheet associates mailboxes with COSs. A sample worksheet for this purpose is shown below. The worksheet section at the end of this manual contains worksheets for photocopying. List all the mailbox owners and their current mailbox numbers on the sheet. Add the new COS numbers for the current mailboxes. If you are going to use broadcast mailboxes, add those mailbox numbers and the COSs to be assigned to them. Remember that the broadcast mailboxes must be new boxes. If possible, use a numbering scheme for the broadcast mailboxes that is easy for the users to remember when they need to give their fax numbers out to callers.

Fax Mail Mailbox Worksheet

Mailbox Owner's Name	Current Mailbox to Update					Fax Broadcast Mailbox to Create			
	Number	FCOS	LCOS	NCOS	Default Telephone Number for Fax Retrieval	Number	FCOS	LCOS	NCOS
Smith	3511	10	1	1	555-3200	6511	21	3	-
Pacheque	4673	10	1	1	555-3200	-	-	-	-

Prepared By: _____ Date: _____

Configured By: _____ Date: _____

Fax Broadcast Mailbox Configuration

If you set up special distribution list mailboxes for fax broadcasting, use the Fax Broadcast Mailbox Worksheet at the end of this manual. A sample worksheet is shown below. Use one worksheet for each distribution list mailbox. Enter the mailbox number to create or modify and the COSs to assign to it, then list the mailboxes and owners' names for the distribution (broadcast) list.

Fax Broadcast Mailbox Worksheet

Mailbox No: 6777 Name: Sales Fax Broadcast

FCOS No: 20 LCOS No: 5 NCOS No: -

Distribution (Broadcast) List

Mailbox #	Owner's Name
4212	Douglass
4256	Garcia
4235	Johnson
4354	Sojourner
4222	Budris
4343	Dayharsh
4274	Vilahu

Mailbox #	Owner's Name

Prepared By: _____ Date: _____

Configured By: _____ Date: _____

Guaranteed Fax Mailbox Configuration

For Guaranteed Fax, use the VIP FCOS with bits 198, 206, and 207 and enable message delivery. This mailbox delivers one copy of each fax message it receives to your fax machine and deletes each fax after it is successfully sent to the machine.

A sample Guaranteed Fax Mailbox Worksheet is shown below. Blank worksheets for photocopying are at the end of this manual. Fill in the telephone numbers in the hunt group. For example, if your fax machine is on 555-3200, assign mailboxes to 555-3201, 555-3202, and so on. Enter the COSs for the mailboxes and the fax number you want them to deliver faxes to.

Guaranteed Fax Mailbox Worksheet

Fax Machine No./Name: 555-3200 Sales Order Entry

Hunt Group Phone Number	Mailbox Number	FCOS	LCOS	Call Fax Number
3201	3201	22	6	3200
3202	3202	22	6	3200

Prepared By: _____ Date: _____

Configured By: _____ Date: _____

Fax Publishing Mailbox Configuration

For fax publishing, you can use any of these types of mailboxes:

- **Tree**
A tree mailbox routes callers to other mailboxes when they press one of the keypad numbers. You must assign the proper features to the mailbox (refer to the *VoiceMemo Reference and Configuration Manual*), create distribution list 01 in the mailbox with the “go to” mailboxes in keypad input order, and record a message in the mailbox directing the caller to press specific keypad numbers for different information. The “go to” mailboxes can also be tree mailboxes, branching the caller further for more specific information.
- **Chain**
A chain mailbox accepts other mailbox numbers from the caller and branches to them. Refer to the *VoiceMemo Reference and Configuration Manual* for chain mailbox features.
- **Greeting with fax**
This mailbox plays your recorded greeting and directs the caller to receive the associated fax.
- **Greeting only**
This type of mailbox can be used within a fax publishing and audiotext application to give a voice only information message, such as the initial welcome greeting to callers.
- **Fax on demand**
Use a greeting only mailbox with bits 194, 195, and 197 to permit callers to receive a prestored fax online or at a caller-designated number.
- **Fax only**
A fax only mailbox plays any greeting and immediately prepares to receive a fax. This can be used in larger fax publishing or audiotext applications to allow the caller to input a fax message.

A sample Fax Publishing Mailbox Worksheet is shown on the next page. Blank worksheets for photocopying are at the back of this manual. For tree and chain publishing, you need a separate worksheet for each mailbox. Number the worksheets and fill the sheet numbers in the “Continue on Sheet” or “Go to Sheet” columns, so you can follow the progression through the tree or chain.

Write out the greeting, if any, that you want recorded in the mailbox. Enter a description or title of the fax document you want stored in the fax transmittal mailbox or attach it to the worksheet.

Fax Publishing Mailbox Worksheet

Mailbox No: 5223 Name: Fax Publishing Index Sheet No: 1

Mailbox Type (Check only one):

Tree Chain Greeting Only Fax Only Greeting with Fax

FCOS No: _____ LCOS No: _____

Tree

Input	Go To Mailbox #	Continue on Sheet #
1		
2		
3		
4		
5		
6		
7		
8		
9		

Chain

Input	Go to Sheet #

Greeting: You have selected the index of all documents available in the fax publishing system

Fax Document: Index

Prepared By: _____ **Date:** _____

Configured By: _____ **Date:** _____

Company Fax Cover Page

The last item you need to plan is your company fax cover page. The cover page is delivered with all faxes, except faxes from users who have their own cover page. Layout an 8.5" by 11" page with your design. You should include your company name, address, telephone number, and fax number. You can also add your company logo and a short message indicating that the fax is from your company.

Fax the company cover page into the system administrator's mailbox(es) from the User Options Menu. You can assign separate administrator's mailboxes, each with a different cover page, to each outbound line group with fax capability.

If you do not enter a company cover page, the system sends a default cover page for users with no personal cover page. The default cover page contains the mailbox owner's name, the number of pages in the fax, the time and date, and if desired, a from field and a promotional field.

Note: If you enter a company cover page, it takes precedence over the default cover page and does not include the dynamic information provided on the default cover page.

If feature bit 200 is not enabled for a mailbox, the system does not send any cover page with faxes from that mailbox.

Company Fax Cover Page Worksheet

Line Group No.	Admin Mailbox No.	FCOS	LCOS	NCOS	Description of Fax Cover Page
1	9998	10	1	1	ABC Comm.
2	9991	10	1	1	Fax-It-To-You

Prepared By: _____ Date: _____

Configured By: _____ Date: _____

Billing Task List

Page 1 of 1

VoiceMemo Release 6.0A and later

Task

Procedure

FaxMemo Reports and Billing

Run a Fax Group Usage Report.....	CP 5316
Set Billing Rates for Disk Usage	CP 4358
Set Billing Rates for Messages Received	CP 4360

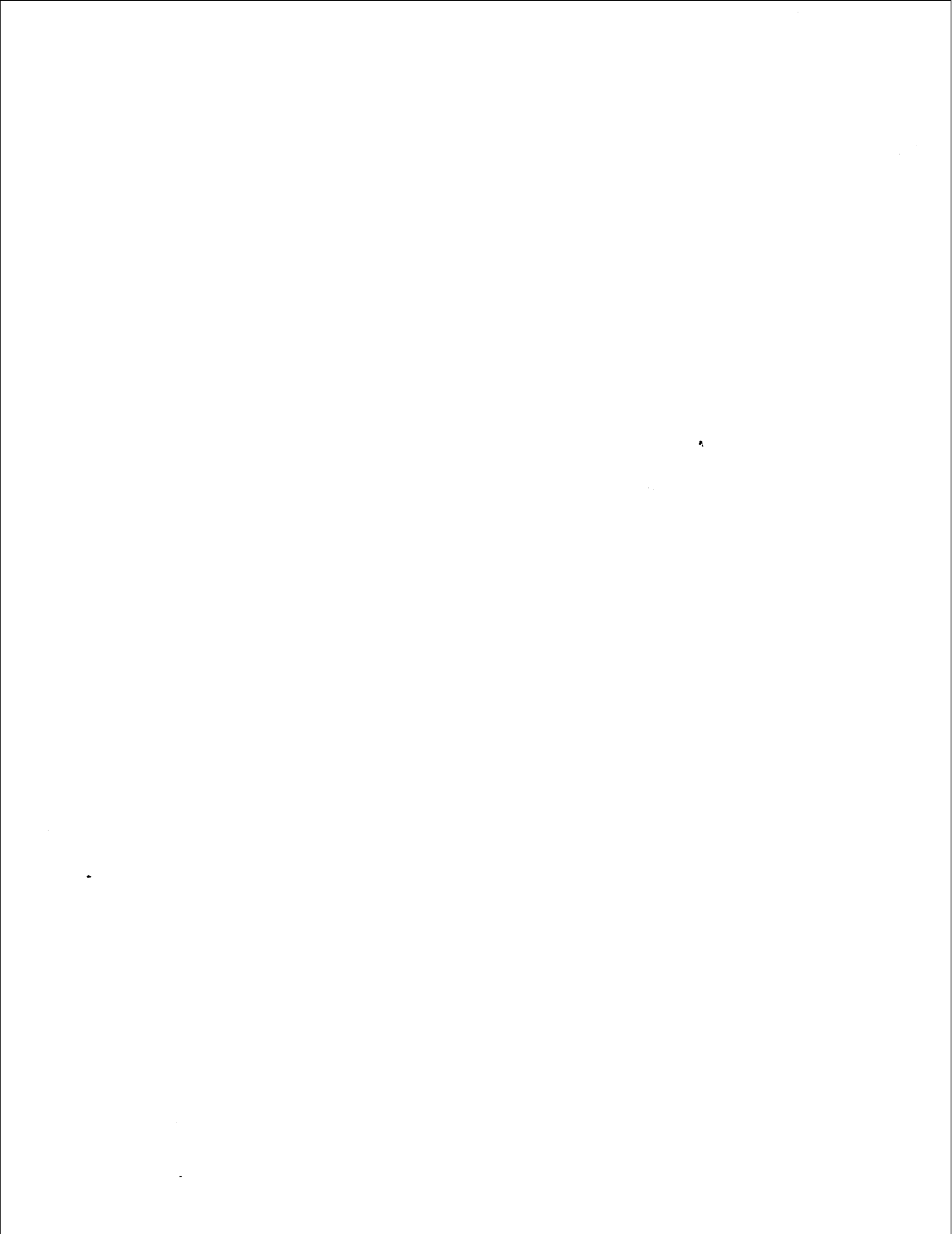

Set Billing Rates for Disk Usage

VoiceMemo Release 6.0A and later

This procedure describes how to set low usage rates, high usage rates, and a high/low boundary for Fax disk usage and other disk usage. The server uses these rates to calculate charges when generating billing reports.

<i>Step</i>	<i>Reference</i>
<p>1. Reach the Billing Menu, then go to the <u>Adjust Billing Rates</u> Menu.</p> <p>2. Set the low usage rate for disk usage other than Fax disk usage.</p> <p><i>Select:</i> (D) Disk Usage</p> <p><i>Prompt:</i> Enter new rate (hit return to keep displayed value). Disk use rates low usage rate (\$ n.nnn) ? \$</p> <p><i>Response:</i> Enter an amount from \$0.01 through \$64.99,</p> <p>or</p> <p>Enter 0.00 to clear the current rate (you must enter two digits after the decimal point when entering an amount or clearing the current rate),</p> <p>or</p> <p>Press Enter to keep the current setting.</p> <p>3. Set the low/high boundary for disk usage.</p> <p><i>Prompt:</i> low/high boundary (n) ?</p> <p><i>Response:</i> Enter a number from 1 through 65535 that represents the number of disk usage units at which the low rate changes to a high rate,</p> <p>or</p> <p>Enter 0 to clear the boundary and establish a uniform rate regardless of amount of usage,</p> <p>or</p> <p>Press Enter to keep the current setting.</p>	Menu Map 9

Step

Reference

4. Set the high usage rate for disk usage.

Prompt: high usage rate (\$ n.nnn) ? \$

Response: Enter an **amount** from \$0.01 through \$64.99,

or

Enter **0.00** to clear the current rate,

or

Press **Enter** to keep the current setting.

5. If you want to set Fax disk usage rates, proceed in the same manner as just described for other disk usage; otherwise, press **Enter** until the short form of the Billing Rates Menu appears.

6. Exit to the Main Menu to make your settings take effect.

Select: (D) Disk Usage

Prompt: Enter new rate (hit return to keep displayed value).
Disk use rates

low usage rate (\$ n.nnn) ? \$

Response: Enter an **amount** from \$0.01 through \$64.99,

or

Enter **0.00** to clear the current rate (you must enter two digits after the decimal point when entering an amount or clearing the current rate),

or

Press **Enter** to keep the current setting.

7. Set the low/high boundary for disk usage.

Prompt: low/high boundary (n) ?

Response: Enter a **number** from 1 through 65535 that represents the number of disk usage units at which the low rate changes to a high rate,

or

Enter **0** to clear the boundary and establish a uniform rate regardless of amount of usage,

or

Press **Enter** to keep the current setting.

<i>Step</i>	<i>Reference</i>
<p>8. Set the high usage rate for disk usage.</p> <p><i>Prompt:</i> high usage rate (\$ n.nnn) ? \$</p> <p><i>Response:</i> Enter an amount from \$0.01 through \$64.99,</p> <p>or</p> <p>Enter 0.00 to clear the current rate,</p> <p>or</p> <p>Press Enter to keep the current setting.</p> <p>9. If you want to set Fax disk usage rates, proceed in the same manner as just described for other disk usage; otherwise, press Enter until the short form of the Billing Rates Menu appears.</p> <p>10. Exit to the Main Menu to make your settings take effect.</p>	

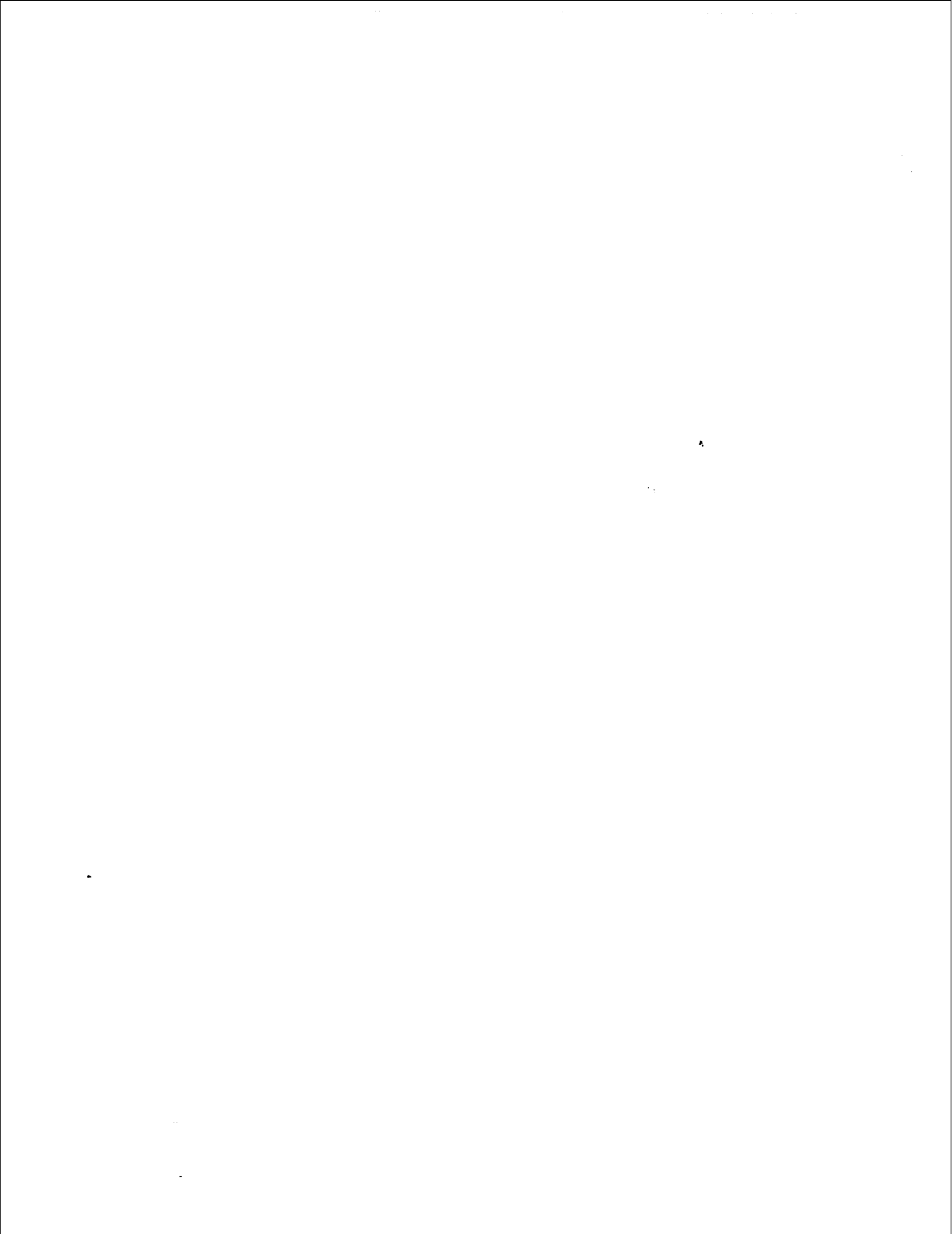

Set Billing Rates for Messages Received

VoiceMemo Release 6.0A and later

This procedure describes how to set low usage rates, high usage rates, and a high/low boundary for types of messages received. The server uses these rates to calculate charges when generating billing reports. Types of messages received are:

- User messages
- Caller messages
- Call placement messages
- Future delivery messages
- Urgent messages
- Wakeup messages
- Receipt response messages
- Fax received, sent, retrieval, and undelivered messages
- Fax pages received, sent, and retrieved messages

<i>Step</i>	<i>Reference</i>
<p>1. Reach the Billing Menu, then go to the <u>Adjust Billing Rates Menu</u>.</p> <p>2. Select the Messages Received option.</p> <p><i>Select:</i> (M) Messages Received</p> <p><i>Prompt:</i> Enter new rate (hit return to keep displayed value). user messages low usage rate (\$ n.nnn) ? \$</p> <p><i>Response:</i> Skip to the desired messages received type, or set the rates and the boundary for user messages.</p> <ul style="list-style-type: none"> • To skip to the desired messages received type, just press Enter in response to the Low Usage Rate, Low/high Boundary, and High Usage Rate prompts until the desired messages received type appears. • To set rates and the boundary for user messages or any other messages received type: <p><i>Prompt:</i> <messages received type> low usage rate (\$ n.nnn) ? \$</p> <p><i>Response:</i> Enter an amount from \$0.01 through \$64.99,</p> <p>or</p> <p>Enter 0.00 to clear the current rate (you must enter two digits after the decimal point when entering an amount or clearing the current rate),</p> <p>or</p> <p>Press Enter to keep the current setting.</p>	Menu Map 9

Step

Reference

Prompt: low/high boundary (n) ?

Response: Enter a **number** from 1 through 65535 that represents the number of units at which the low rate changes to a high rate,

or

Enter **0** to clear the boundary and establish a uniform rate regardless of amount of usage,

or

Press **Enter** to keep the current setting.

Prompt: high usage rate (\$ n.nnn) ? \$

Response: Enter an **amount** from \$0.01 through \$64.99,

or

Enter **0.00** to clear the current rate,

or

Press **Enter** to keep the current setting.

3. Exit to the Main Menu to make your settings take effect.

Run a Fax group Usage Report

VoiceMemo Release 6.0A and later

This procedure describes how to enter the parameters for a fax group usage report, and how to run the report in both standard and summary forms.

<i>Step</i>	<i>Reference</i>
<p>1. Reach the Statistics Menu, then go to the Fax Group Usage Report Menu.</p> <p><i>Select:</i> (F) Fax Group usage <i>Prompt:</i> ENTER : <i>Response:</i> Enter menu parameters as described in the next section.</p>	Menu Map 9
<p>☺☺☺ Specify the Report Parameters</p>	
<p>2. Choose the group or range of groups to report.</p> <p><i>Select:</i> (A) Beginning Group <i>Prompt:</i> Beginning group (1-42) : <i>Response:</i> Enter a fax group number between 1 and 42.</p> <p><i>Select:</i> (B) Ending Group <i>Prompt:</i> Ending group (1-42) : <i>Response:</i> Enter a fax group number between 1 and 42. To report on only one group, enter the same group number entered in the beginning group field.</p>	
<p>3. Select the time interval for the report.</p> <p><i>Select:</i> (C) Beginning Hour <i>Prompt:</i> Beginning hour (0-23) : <i>Response:</i> Enter the number, in military time, of the first hour of the time period for the report. The default is 8:00 a.m. (8). The range is 0 to 23 hours. 0 (zero) is midnight, 12 is noon, and 23 is 11:00 p.m.</p> <p><i>Select:</i> (D) Ending Hour <i>Prompt:</i> Ending hour (0-23) : <i>Response:</i> Enter the number, in military time, of the last hour of the time period for the report. The default is 5:00 p.m. (17). The range is 0 to 23 hours.</p>	

Step

Reference

4. Select the day or days for the report.

Select: (E) Beginning Day

Prompt: Beginning day of week Sun-Sat (0-6):

Response: Enter **number** of the first day of the period for the report.

Sunday	=	0
Monday	=	1
Tuesday	=	2
Wednesday	=	3
Thursday	=	4
Friday	=	5
Saturday	=	6

The default is Monday (1).

Select: (F) Ending Day

Prompt: Ending day of week Sun-Sat (0-6):

Response: Enter **number** of the last day of the period for the report. See the beginning day for a listing of the day numbers. The default is Friday (5).

5. Specify whether you want the report in a summary form or in a detail form.

Select: (G) Summary

Prompt: Summary:

Response: **Y** to run a summary report,
N to run a standard report with details in 15 minute intervals.

*Step**Reference*

☉☉☉ Run the Report

6. Run the report.

Select: (R) Run Report
Prompt: REPORT OUTPUT ROUTING

(C) Console (screen)
(P) Console with pause
(1) Printer A
(F) File...
(A) Append to file...
(X) Exit (no report)

If you need help later, type ?.

COMMAND (C/P/1/F/A/X):

Response: C to send the report to the console without pausing
P to send the report to the console, pausing as the screen fills,
1 to send the report to printer A*,
F to send the report to a file on the Series 6 server,
A to append the report to an existing file on the Series 6 server, or
X to exit report output options (no report).

* You can have one or more serial ports on your server with different devices, depending on the configuration of your server.

The system displays the report to the output device you select. If you are sending it to the console without pausing, use the following commands to control scrolling:

To stop scrolling: Press **Ctrl-S**
To restart scrolling: Press **Ctrl-Q**

Step

Reference

- Figure 1 is a sample Fax Group Usage Report.

```

FAX GROUP USAGE 15min REPORT
  Fri Apr 21, 1995  9:12 am

04/17/95  8hr-17hr      --- minutes interval ---
Fax Group 1 []

DAY=01 HOUR=08          00-14    15-29    30-44    45-59    TOTAL  BUSY
Transactions            0         0         0         0         0
Total Use                0         0         0         0         0
No Resource Count       0         0         0         0         0
ATB Seconds              0         0         0         0         0      0 %
ATB Count                0         0         0         0         0

DAY=01 HOUR=09          00-14    15-29    30-44    45-59    TOTAL  BUSY
Transactions            2         1         0         0         3
Total Use               102        51         0         0        153
No Resource Count       0         0         0         0         0
ATB Seconds              0         0         0         0         0      0 %
ATB Count                0         0         0         0         0

DAY=01 HOUR=10          00-14    15-29    30-44    45-59    TOTAL  BUSY
Transactions            0         0         0         2         2
Total Use                0         0         0         85        85
No Resource Count       0         0         0         0         0
ATB Seconds              0         0         0         0         0      0 %
ATB Count                0         0         0         0         0

HIGHEST ATB_SEC: 0 sec at 8,9,10,11,12,13,14,15,16,17 hr
LOWEST  ATB_SEC: 0 sec at 8,9,10,11,12,13,14,15,16,17 hr
  
```

Figure 1 Sample Fax Group Report

- Figure 2 is a sample Fax Group Usage Summary Report.

```

TOTAL FAX GROUP ATB SUMMARY REPORT
  Fri Apr 21, 1995  9:10 am

04/17/95  8hr-17hr  day1-day5

GROUP          TRANSACTIONS TOT SEC NO RES    ATB CNT ATB SEC BUSY
-----          -
1              83      4278     0         0         0  0 %
2              17       513     1         0         0  0 %
  
```

Figure 2 Sample Summary Fax Group Report

5 FaxMemo Billing and Statistics

You can set FaxMemo billing rates for the following types of usage:

- Number of received fax messages
- Number of sent fax messages
- Retrieval of non-billed fax messages
- Retrieval of billed fax messages
- Undelivered fax messages
- Number of fax pages received
- Number of non-billed fax pages received
- Number of billed fax pages received
- Fax disk usage

These different usages can be combined in many ways to provide users with defined billing levels. This chapter describes each usage type. For instructions on how to produce billing reports refer to the *VoiceMemo Reference and Configuration Manual*.

Series 6 servers offer two other methods of billing mailbox owners for fax usage. Fax transactions are recorded in Call Detail Recorder records, which can be downloaded to a computerized billing system for interpretation and billing. Or the server can place fax calls using mailbox owners' long distance carriers and calling card numbers. This can eliminate the need for any further billing, because there is no toll incurred by the server.

Billing Parameters

The Billing Menu, reached from the Reports Menu, identifies several categories of system usage that you can configure for billing. The categories of Messages Received and Disk Usage contain fax fields.

Messages Received

Messages Received contains fields both for faxes received and faxes sent. You can bill fax messages either on the number of messages or the number of pages. Additionally, you can bill retrieved fax messages in two categories: those for which the call was placed using the mailbox owner's calling card (billed messages), or those that were dialed without using a calling card (non-billed messages). You can also place a rate on undelivered fax messages, which incur storage space while on the system.

For each of the fax fields in Messages Received Billing, you can set two rates: one for instances below a certain boundary (for example, the first ten faxes received each billing period), and another for each instance above the boundary (all faxes received after the first ten). You can also set the boundary between low and high usage.

Fax Received Messages

This billing parameter allows you to bill mailbox owners based on the number of faxes that they receive during a billing period.

Fax Sent Messages

This billing parameter allows you to bill mailbox owners based on the number of faxes that they make or give during a billing period. If a mailbox owner sends/gives a fax to a distribution list, each member of the distribution list counts as one fax message sent.

Fax Retrieval Non-Billed Messages

This parameter bills mailbox owners for each successful outgoing fax call that the server makes using a non-billed access code. These calls may be local or long distance, depending on the configuration of access codes and the mailbox LCOS. Faxes that callers retrieve during a VoiceMemo session are not counted in this billing parameter.

Fax Retrieval Billed Messages

This parameter bills mailbox owners for each successful outgoing fax call that the server makes using a billed access code. These fax calls are made using the mailbox owner's long-distance carrier and calling card, thus the server does not incur any toll charges for the calls. Faxes that callers retrieve during a VoiceMemo session are not counted in this billing parameter.

Fax Undelivered Messages

You can use this billing parameter to charge for fax messages that are received into a mailbox, but never delivered to a fax machine. These messages are eventually purged from the system due to age.

Fax Pages Received Messages

This billing parameter allows you to charge mailbox owners based on the number of fax pages received, regardless of the total number of faxes. If you are trying to serve a lot of customers with few fax ports, it may work better to bill your customers for fax pages rather than total faxes (see "Fax Received Messages," above), since a single fax that contains many pages can occupy a fax port for several minutes.

Fax Pages Sent Messages

This billing parameter allows you to charge mailbox owners based on the number of fax pages sent, regardless of the total number of faxes. If you are trying to serve a lot of customers with few fax ports, it may work better to bill your customers for fax pages rather than total faxes (see "Fax Sent Messages," above), since a single fax that contains many pages can occupy a fax port for several minutes.

Fax Pages Retrieval Non-Billed Messages

This parameter bills mailbox owners for each page of successful outgoing fax calls that the server makes using a non-billed access code. These calls may be local or long distance, depending on the configuration of access codes and the mailbox LCOS. Faxes that callers retrieve during a VoiceMemo session are not counted in this billing parameter.

Fax Pages Retrieval Billed Messages

This parameter bills mailbox owners for each page of successful outgoing fax calls that the server makes using a billed access code. These fax calls are made using the mailbox owner's long-distance carrier and calling card, thus the server does not incur any toll charges for the calls. Faxes that callers retrieve during a VoiceMemo session are not counted in this billing parameter.

Disk Usage

Disk Usage billing allows you to charge mailbox owners for the amount of storage used by their mailbox during a billing period. Fax messages, like voice messages, occupy space on the system's hard disks. You can bill at different rates for voice messages and fax messages, if desired.

Fax Disk Use Rates

Simply stated, this billing parameter sets a cost for fax storage on the system's hard disk(s). Storage used during a billing period is the result of the size of each message times the length of time that the mailbox owner has it in his or her mailbox.

Because the density (amount of information) of a fax page varies, fax disk usage is not measured in units of pages or total faxes. Instead, fax disk usage is measured in units of comparable voice storage. In other words, if a fax message stored on the system's hard disk(s) takes up as much space as a two-minute message, it would be billed the same as a two-minute message. If a mailbox owner kept that fax message for five days before discarding it, the total usage would equal ten minutes of storage.

The average double-spaced fax page (8.5" x 11") requires the same amount of storage as about 12 seconds of voice recording. A very dense fax page can use the equivalent storage space as 40 or more seconds of voice recording.

As with the Messages Received parameters, you can set a low usage rate, high usage rate, and boundary for Fax Disk Use. The boundary is in units of equivalent voice storage minutes.

Fax Statistics

The Series 6 server can produce individual mailbox and system-wide statistics on fax usage.

Mailbox Statistics

The Mailbox Dump report for individual mailboxes contains many pieces of information relating to FaxMemo. In addition to identifying the mailbox configuration, including COSs assigned to the mailbox, the report shows:

- Whether the mailbox has a fax cover page or greeting
- The number of fax messages and pages received
- The number of fax messages and pages sent
- The number of fax messages and pages delivered (downloaded) by the user to a fax machine
- The number of undelivered faxes
- The disk space used by faxes in the mailbox

System Statistics

The Mailbox Statistics report (reached from the Statistics Menu) contains information about the total amount of disk space used for fax storage. Within the Speech Statistics section of the Total Speech and Account Breakdown report are numbers for:

- The number of fax greetings and messages on the system, and the total number of frames and blocks that each occupies. The report also shows the percentage of storage blocks filled by each type of fax.
- A summary of the number of storage blocks used by both fax messages and greetings combined.

Fax Group Usage Report

This report provides several pieces of information regarding fax group usage that you can use to monitor your system configuration. The reporting period can be any portion of the most recent seven days, and any hour or range of hours during those days. You can choose either a full report, which gives the statistics in 15-minute increments, or a summary report, which you can use to scan for possible problem areas.

Figure 5-1 is a sample Fax Group Usage Report followed by an explanation of how to read the report. Figure 5-2 is a sample Total Fax Group ATB Summary Report.

FAX GROUP USAGE 15min REPORT							
Mon Jan 30, 1995 7:50 am							
01/23/95 8hr	--- minutes interval ---						
Fax Group 1							
DAY=01 HOUR=08	00-14	15-29	30-44	45-59	TOTAL	BUSY	
Transactions	1	8	22	21	52		
Total Use	123	984	2706	2583	6396		
No Resource Count	0	0	1	0	1		
ATB Seconds	0	0	10	2	12	1 %	
ATB Count	0	0	1	1	2		
HIGHEST ATB_SEC: 10 sec at 8 hr							
LOWEST ATB_SEC: 0 sec at 8 hr							

Figure 5-1 Sample Fax Group Usage Report

Reading the Fax Group Usage Report

The report heading shows the date and time that the report was run.

The first line of the report shows the date and time interval during which the data was gathered.

Fax Group *n* The following information concerns this fax group.

DAY=01 HOUR=08 The data displayed immediately below refers to traffic on day 1 (Monday) between the hours of 8:00 am and 9:00 am. 00-14 indicates that data in that column was gathered during the first fifteen minutes of the hour; 15-29 refers to the second 15 minutes of the hour, and so on.

Total The combined data for the four 15-minute intervals. If this column contains a hyphen, it means that the data for that hour has not yet been gathered. For example, if the report is run at 3:30 p.m., and the report interval is for hours 12-15 (noon to 3 p.m.) the entries for the hour 15 (3 to 4 p.m.) show hyphens.

Transactions The total number of fax receptions/transmissions that the fax group processed during the time period. Note that this does not reflect the number of fax pages nor the number of faxes; a single outgoing fax call (a transaction) could send several faxes from one mailbox.

If a fax transaction spans two reporting periods, the Total Use fields show the time used in each period. The Transactions field counts the fax in the period in which the transaction started.

Total Use The number of seconds that the channels in the fax group were involved in fax transactions during the time period.

No Resource Count The number of times that all fax channels in the fax group were in use and another voice port requested a fax channel. This indicates that the fax group is too small to service all requests and some requests are being rejected.

ATB Seconds The total number of seconds that all fax channels in the fax group were in use simultaneously.

Busy The percentage of the hour that all fax channels were busy and the potential for request rejection existed.

ATB Count The number of times that all fax channels in the fax group were in use simultaneously.

HIGHEST ATB_SEC: This statistic identifies the busiest hour(s) for the fax group during the entire reporting period, and the number of seconds that all channels were busy during that hour.

LOWEST ATB_SEC: This statistic identifies the hour(s) that had the least amount of time when all channels were busy.

TOTAL FAX GROUP ATB SUMMARY REPORT							
Mon Jan 30, 1995 4:24 pm							
01/23/95 8hr-17hr day1-day5							
GROUP	TRANSACTIONS	TOT SEC	NO RES	ATB CNT	ATB SEC	BUSY	

1	345	60030	1	2	12	1 %	

Figure 5-2 Sample Fax Summary Report

The fields in the Fax Summary Report are identical to the fields in the Fax Group Usage Report. The data reported is the summary for the entire reporting period. You can use the report to monitor fax group usage, and to look for possible trouble spots. You can then decide whether you need to run the more detailed Fax Group Usage Report.

6 FaxMemo Troubleshooting

This chapter provides instructions on how to troubleshoot the FaxMemo optional feature. If you are unable to resolve a problem after following the guidelines below, contact your distributor or Centigram technical support.

Configuration Problems

The majority of reported problems with FaxMemo are caused by misconfiguration. Before testing for bad hardware, check the following areas of your VoiceMemo configuration:

- Run a System Configuration Report and verify that each line group that is used for fax transactions has fax resources assigned to it.
- Run a Fax Group Usage Report and make sure that there is little or no blockage. If there are not enough fax resources (channels) assigned to a line group, fax calls may fail.
- Examine LCOS settings to make sure that limits are set appropriately for FaxMemo users. See Chapter 4 for more information on LCOS settings.
- Examine FCOS settings to ensure that the correct features are enabled for FaxMemo application mailboxes and users. See Chapter 4 for more information on FCOS settings.
- Check the configuration of any mailboxes that are reporting problems and make sure that they are assigned to classes of service that support FaxMemo.

Hardware Problems

If the VoiceMemo configuration seems to be okay, the problem may be in the sending/receiving fax machine or the MVIP FaxMemo cards. Follow these guidelines to help isolate the problem.

- If users are reporting a problem with a specific fax machine, use a different fax machine and attempt to send and/or receive a fax using the mailbox that is having the problem.

- If you hear the prompt:
Fax message complete
or
Your fax sent

the problem is probably with the receiving fax machine. Test the fax machine according to the manufacturer's instructions.

- If you hear the following prompt
I'm sorry, I did not get your fax message
or
I'm sorry, I could not deliver your fax message

the problem is probably with a FaxMemo Card.

- If a FaxMemo Card failure is indicated, look at the most recent Offline Configuration Programming Sheet to determine which card or cards might be involved.
- Check error logs for errors involving fax.
- Examine fax LEDs for transmit/receive status.
- Remove the failed card, reconfigure a new FaxMemo Card, and install it in the failed card's slot.
- Return the failed card to your distributor or to Centigram. Refer to Customer Support Note 49, Return Material Traveler for customer service procedures.

Worksheets

The following worksheets are provided here without manual headers and footers for your photocopying. After copying, return the originals to this section for future use.

- FaxMemo Card Planning Worksheet
- FaxMemo COS Planning Worksheet
- Fax Mail Mailbox Worksheet
- Fax Publishing Mailbox Worksheet
- Guaranteed Fax Mailbox Worksheet
- Fax Broadcast Mailbox Worksheet
- Company Fax Cover Page Worksheet

FaxMemo Card Planning Worksheet

Hardware

Module No.	Backplane Slot No.	FaxMemo Card Serial No.	Number of Channels	Base I/O Address

Configuration

Fax Group #: _____ Module #: _____ Total Number of Channels: ____

Connect with Line Group(s): _____ Dedicated Shared

Slot	Channel

Slot	Channel

Prepared By: _____ Date: _____

Configured By: _____ Date: _____

FaxMemo COS Planning Worksheet

Fax FCOS Bits

Number	Description
190	Receive Fax Messages
191	Make Fax Messages
192	Give Fax Messages
193	Deliver Fax to Default Fax Phone Number
194	Deliver Fax Online
195	Deliver Fax to Designated Phone Number
196	User Changeable Default Fax Phone Number for Fax Delivery
197	Fax on Demand
198	Receive Fax Messages Only
199	Automatic Receipt for Fax Sent
200	Personal Fax Cover Page
203	Walkaway Fax
206	Fax Delete

Fax FCOS Bits (continued)

207	Fax Verify
230	Deny Changes to Fax Cover Page Options
235	Add "From" Field on Fax Cover Page
236	Add "Promotional" Field on Fax Cover Page
237	Automatic Fax Retrieval
238	End of Session Delivery
239	Retrieve All Unplayed Faxes
240	Receive Fax on Record Time-Out
256	Enable Fixed Greeting for Walkaway Fax

Fax NCOS Bits

Number	Description
10	Make Fax Message to Network
11	Give Fax Message to Network
12	Answer Fax Message to Network

COSs for User's Normal Mailbox

FCOS # to Modify	New FCOS Number	New FCOS Name	FAX FCOS Bits to Add

LCOS Number	Number of Digits for Fax Delivery	# Fax Msgs per Mailbox	Fax Delivery Retry Frequency	Fax Delivery Retry Interval	CNG Tone Detection Length	Played Fax Msg Retention	Unplayed Fax Msg Retention	Urgent Fax Msg Retention	Fax Receipt Retention

NCOS # to Modify	New NCOS Number	New NCOS Name	FAX NCOS Bits to Add

FCOS for User's Fax Broadcast Mailbox

FCOS # to Modify	New FCOS Number	New FCOS Name	FAX FCOS Bits to Add

Prepared By: _____ Date: _____

Configured By: _____ Date: _____

Fax Publishing Mailbox Worksheet

Mailbox No: _____ Name: _____ Fax Publishing Index: _____ Sheet No: _____

Mailbox Type (Check only one):

Tree
 Chain
 Greeting Only
 Fax Only
 Greeting with Fax

FCOS No: _____ LCOS No: _____

Tree

Input	Go To Mailbox #	Continue on Sheet #
0		
1		
2		
3		
4		
5		
6		
7		
8		
9		

Chain

Input	Go to Sheet #

Greeting: _____

Fax Document: _____

Prepared By: _____ Date: _____

Configured By: _____ Date: _____

Guaranteed Fax Mailbox Worksheet

Fax Machine No./Name: _____

Hunt Group Phone Number	Mailbox Number	FCOS	LCOS	Call Fax Number

Prepared By: _____ Date: _____

Configured By: _____ Date: _____

Fax Broadcast Mailbox Worksheet

Mailbox No: _____ Name: _____

FCOS No: _____ LCOS No: _____ NCOS No: _____

Distribution (Broadcast) List

Mailbox #	Owner's Name

Mailbox #	Owner's Name

Prepared By: _____ Date: _____

Configured By: _____ Date: _____

Company Fax Cover Page Worksheet

Line Group No.	Mailbox No.	FCOS	LCOS	NCOS	Description of Fax Cover Page

Prepared By: _____ Date: _____

Configured By: _____ Date: _____

List of Centigram Procedures

Page 1 of 3

Procedure Number	Chapter Number	Title	CPs Called	Called By
CP 2146	3	Replace an MVIP Fax Card	CP 5700	
CP 4358	5	Set Billing Rates for Disk Usage		CP 6450 CP 6451 CP 6452 CP 6453
CP 4360	5	Set Billing Rates for Messages Received		CP 6450 CP 6451 CP 6452 CP 6453
CP 5007	4	Customize an FCOS Copy		CP 6450 CP 6451 CP 6452 CP 6453
CP 5008	4	Customize a Default FCOS		
CP 5011	4	Add or Delete Feature Bits		CP 6450 CP 6451 CP 6452 CP 6453
CP 5015	4	Verify Configuration Parameters		CP 6450 CP 6451 CP 6452 CP 6453
CP 5316	5	Run a Fax Group Usage Report		
CP 5402	4	Install an Optional Feature		CP 6449
CP 5700	4	Shut Down the System		CP 6449
CP 6449	4	Add FaxMemo to a Series 6 Server	CP 5402 CP 5700 CP 7510	
CP 6450	4	Configure for Fax Mail	CP 4358 CP 4360 CP 5007 CP 5011 CP 5015 CP 7002 CP 7506 CP 7508 CP 7509 CP 7512	

List of Centigram Procedures

Page 2 of 3

Procedure Number	Chapter Number	Title	CPs Called	Called By
CP 6451	4	Configure for Fax Publishing	CP 4358 CP 4360 CP 5007 CP 5011 CP 5015 CP 7002 CP 7506 CP 7508 CP 7509 CP 7512	
CP 6452	4	Configure for Guaranteed Fax	CP 4358 CP 4360 CP 5007 CP 5011 CP 5015 CP 7002 CP 7506 CP 7508 CP 7509 CP 7512	
CP 6453	4	Configure for Fax Broadcast	CP 4358 CP 4360 CP 5007 CP 5011 CP 5015 CP 7002 CP 7506 CP 7508 CP 7509 CP 7512	
CP 6454	4	Setup a Company Fax Cover Page		
CP 7002	4	Activate the Inactive Configuration		CP 6450 CP 6451 CP 6452 CP 6453
CP 7506	4	Configure a Mailbox for FaxMemo		CP 6450 CP 6451 CP 6452 CP 6453

Procedure Number	Chapter Number	Title	CPs Called	Called By
CP 7508	4	Set Limits for FaxMemo		CP 6450 CP 6451 CP 6452 CP 6453
CP 7510	3	Install an MVIP Fax Card		CP 6449
CP 7511	3	Remove an MVIP Fax Card	CP 5700	
CP 7512	4	Define a Fax Group		CP 6450 CP 6451 CP 6452 CP 6453

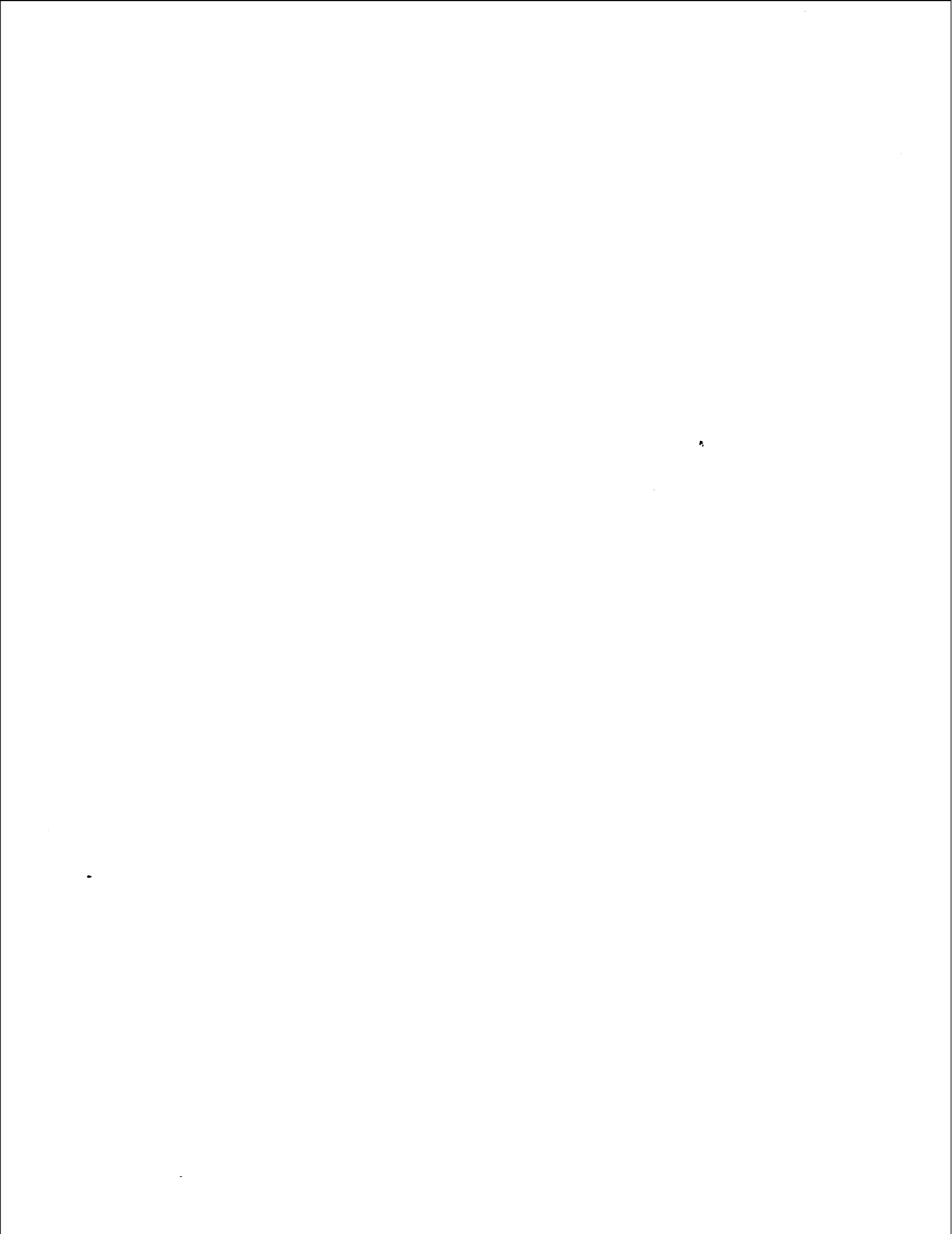

Index

A

access
 planning, 2-1
adding FaxMemo options, 4-9
automatic exit, avoiding, xii

B

billing, 5-1
 disk usage, 5-3, CP 4358 (5)
 fax disk use rates, 5-3
 fax messages received, 5-2
 fax messages retrieved, billed, 5-2
 fax messages retrieved, non-billed, 5-2
 fax messages sent, 5-2
 fax pages received, 5-2
 fax pages retrieved, billed, 5-3
 fax pages retrieved, non-billed, 5-3
 fax pages sent, 5-3
 messages received, 5-1, CP 4360 (5)
 overview, 1-6
 undelivered fax messages, 5-2
broadcast fax mailbox, user
 description, 2-1, 4-10

C

call routing, *See fax call routing*
chain mailbox
 use in Fax Publishing, 4-15
classes of service, 4-1
CNG tone
 detecting, 4-8
configuration
 activating, CP 7002 (4)
 inactive, CP 7002 (4)
 prerequisites, xiii
 software, planning, 4-1
 verify parameters, CP 5015 (4)

console, tips, xi
cover page
 "from" field, 4-6
 company, 1-5, 4-4, 4-17
 company, configuration, CP 6454 (4)
 company, worksheet, 4-17
 default, 1-5, 4-4, CP 7509 (4)
 default, contents, 1-5
 deny changes, 4-5
 options, 1-5
 personal, 1-5, 4-4
 precedence, 4-17
 promotional field, 4-6
 system, *See cover page, company*

D

dedicated fax group, *See fax group, dedicated*
default fax phone number, 4-3
defaults, accepting, xi
designated fax phone number, 4-3
DID, *See fax call routing, DID*
disk space
 fax requirements, 5-3
distribution list
 for Fax Broadcast, 4-13

E

end of session delivery, 4-6

F

Fax Broadcast
 configuration summary, CP 6453 (4)
 description, 1-3
 mailbox configuration, 4-13
 mailbox worksheet, 4-13
 port requirements, 3-2

Index

- fax call routing
 - DID, 2-2
 - general access, 2-6
 - switch integration, 2-2
 - TIE trunks, 2-5
- fax cards
 - communication with line cards, 1-6, 3-1
 - connection to telephone service, 3-1
 - digital, installing, CP 7510 (3)
 - on MVIP bus, 1-6
 - planning worksheet, 3-5
 - removing, CP 7511 (3)
- fax delivery
 - retry frequency, 4-8
 - retry interval, 4-8
- Fax Group Usage Report, CP 5316 (5)
- fax groups
 - dedicated, 1-7, 3-4
 - defining, CP 7512 (4)
 - inbound, 3-4
 - outbound, 3-4
 - shared, 3-4
 - two-way, 3-4
 - usage report, 5-5
- fax limits, 4-7
- Fax Mail
 - configuration summary, CP 6450 (4)
 - description, 1-2
 - mailbox configuration, 4-12
 - mailbox worksheet, 4-12
 - notification, 1-2
 - port requirements, 3-2
 - retrieving online, 1-2
 - sending to a fax machine, 1-2
- fax message retention
 - played messages, 4-8
 - receipts, 4-8
 - unplayed messages, 4-8
 - urgent messages, 4-8
- fax messages
 - delete, 4-5
 - deliver online, 4-3
 - deliver to default fax phone number, 4-3
 - deliver to designated fax phone number, 4-3
 - give, 4-2
 - make, 4-2
 - receive, 4-2
 - storage space requirements, 5-3
 - verify, 4-5
- fax networking features, 4-9
- fax on demand, 4-4, 4-15
- fax only mailbox, 1-3, 4-15
- fax phone number
 - default, 4-3
 - designated, 4-3
 - dial string characters, CP 7506 (4)
 - number of digits, 4-7
 - specifying, CP 7506 (4)
 - user changeable, 4-3
- Fax Publishing
 - configuration summary, CP 6451 (4)
 - description, 1-3
 - fax on demand, 4-4
 - mailbox configuration, 4-15
 - mailbox worksheet, 4-16
 - port requirements, 3-3
- fax receipt retention, 4-8
- fax receipts
 - automatic, 4-4
- fax resources
 - availability, 3-4
 - guaranteed availability, 3-4
- fax retrieval
 - automatic, 4-6
- faxes messages
 - retrieving, 4-7
- FaxMemo
 - adding to a Series 6 server, 6449 (4)
 - basic operation, 1-1
 - benefits, 1-2
 - billing, *See billing*
 - classes of service, 4-1
 - concept, 1-1
 - description, 1-1
 - equipment supplied, 1-7
 - FCOS options, 1-4
 - hardware configuration rules, 3-3
 - hardware overview, 1-6
 - LCOS options, 1-4, CP 7508 (4)
 - NCOS options, 1-5
 - port requirements, 3-2
 - reports, *See statistics*

- statistics, *See statistics*
- system requirements, 1-7
- troubleshooting, 6-1
- FaxMemo options
 - adding, 4-9
- FCOSs
 - copying, CP 5007 (4)
 - defaults, CP 5008 (4)
 - Fax Broadcast, CP 6453 (4)
 - Fax Mail, CP 6450 (4)
 - Fax Publishing, CP 6451 (4)
 - Guaranteed Fax, CP 6452 (4)
 - modifying, CP 5011 (4), CP 5008 (4), CP 5007 (4)
 - renumbering a default, CP 5008 (4)
- feature bits
 - 190, 4-2
 - 191, 4-2
 - 192, 4-2
 - 193, 4-3
 - 194, 4-3
 - 195, 4-3
 - 196, 4-3
 - 197, 4-4
 - 198, 4-4
 - 199, 4-4
 - 200, 4-4
 - 203, 4-5
 - 206, 4-5
 - 207, 4-5
 - 230, 4-5
 - 235, 4-6
 - 236, 4-6
 - 237, 4-6
 - 238, 4-6
 - 239, 4-7
 - 240, 4-7
 - 256, 4-7
 - adding, CP 5011 (4)
 - deleting, CP 5011 (4)
 - descriptions, 4-2
- fixed greeting
 - with walkaway fax, 4-7

G

- greeting only mailbox
 - fax on demand, 4-4
 - use in Fax Publishing, 4-15
- Guaranteed Fax
 - configuration summary, CP 6452 (4)
 - description, 1-3
 - fax delete, 4-5
 - fax verify, 4-5
 - mailbox configuration, 4-14
 - mailbox worksheet, 4-14
 - port requirements, 3-2
 - receive fax messages only, 4-4

H

- hardware installation
 - planning, 3-1

I

- installation
 - optional feature, CP 5402 (4)

L

- LCOS limits parameters
 - CNG Tone Detection Length, 4-8
 - Fax Broadcast, CP 6453 (4)
 - Fax Delivery Retry Frequency, 4-8
 - Fax Delivery Retry Interval, 4-8
 - Fax Mail, CP 6450 (4)
 - Fax Phone Number Length, 4-7
 - Fax Publishing, CP 6451 (4)
 - Fax Receipt Retention, 4-8
 - FaxMemo, CP 7508 (4)
 - FaxMemo Message Count, 4-8
 - Guaranteed Fax, CP 6452 (4)
 - Played Fax Message Retention, 4-8
 - Unplayed Fax Message Retention, 4-8
 - Urgent Fax Message Retention, 4-8
- line signaling, 3-1

M

mailbox configuration

- Fax Broadcast, 4-13
- Fax Mail, 4-12
- Fax Publishing, 4-15
- Guaranteed Fax, 4-14

mailboxes

- configuring for FaxMemo, CP 7506 (4)

menus

- returning to main, xi
- viewing complete, xi

message delivery

- use in Guaranteed Fax, 4-14

message waiting, 4-6

MVIP card, replacing, CP 2146 (3)

MVIP fax cards, 1-6

N

NCOS network parameters

- Fax Mail, CP 6450 (4)

Network

- answer fax messages to, 4-9
- give fax messages to, 4-9
- make fax messages to, 4-9

O

offline configuration, 4-1

optional features, installing, CP 5402 (4)

P

phantom extension, *See fax call routing, switch integration*

planning

- hardware installation, 3-1

procedures

- documentation conventions for, ix

promotional message, 4-6

- on default cover page, 1-5

R

RCOS

- and FaxMemo, 4-9

receipts, *See fax receipts*

receive fax messages only, 4-4

reports

- fax group usage, 5-5, CP 5316 (5)

retrieve all unplayed faxes, 4-7

routing, *See fax call routing*

S

shortcut commands, xii

software configuration

- planning, 4-1

statistics, 5-1, 5-4

- mailbox, 5-4

- overview, 1-6

- system, 5-4

storage

- fax requirements, 5-3

system shutdown, CP 5700 (4)

T

time zones

- configuring, CP 7509 (4)

- offset, CP 7509 (4)

timeouts, avoiding, xii

tree mailbox

- use in Fax Publishing, 4-15

troubleshooting, 6-1

W

Walkaway Fax, 4-5, 4-7

- description, 1-3

- fixed greeting, 4-7

- in Fax Broadcast, CP 6453 (4)

- port requirements, 3-3

warnings, documentation conventions for, x

worksheet

- Company Fax Cover Page, 4-17

- Fax Broadcast Mailbox, 4-13

- Fax Mail Mailbox, 4-12

- Fax Publishing Mailbox, 4-16

- FaxMemo Card Planning, 3-5

- FaxMemo COS Planning, 4-10, 4-11

- Guaranteed Fax Mailbox, 4-14

Issue 1 Release 2.0 January 1996

MITEL MAIL™

Voice Processing Solutions



Receptionist II
Manual



MITEL®

™, ® - Trademark of Mitel Corporation
© Copyright 1996, Mitel Corporation
All rights reserved.
Printed in Canada.

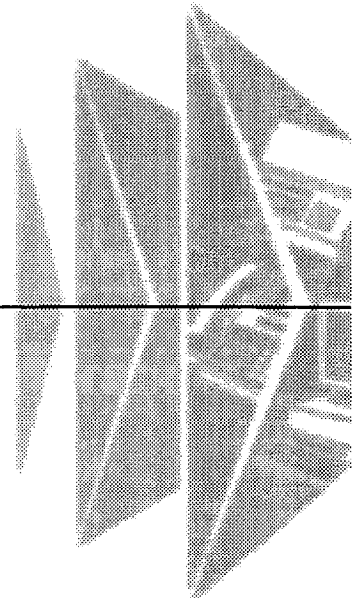

Table of Contents

About This Manual

Who Should Read This Manual.....	vii
How to Use This Manual	vii
Reference Chapters.....	vii
Task Lists	vii
Procedures.....	viii
Menu Maps and Other Navigation Aids.....	viii
Worksheets.....	ix
Conventions Used in This Manual	ix
Reader Advisories	x
Before You Start.....	xi
Console Tips and Techniques	xi
Viewing Menus.....	xi
Accepting Defaults	xi
Avoiding Automatic Exit.....	xi
Quitting an Entry Session	xii
Shortcut Commands.....	xii

1 Introduction

Receptionist II Features.....	1-2
Console Attendant Functions	1-2
Day/Night Greetings.....	1-2
Configurable Prompts Languages	1-2
Automatic Outdialing to Trunks	1-2
Call Screening/Automatic Announcement for Users.....	1-2
Flexible Rerouting of Calls	1-2
Customized Treatments for Individual Users.....	1-3
Separate Day and Night/Weekend Call Treatments for Individual Users	1-3
Directory/Menu Capabilities.....	1-3
Single-Digit Access	1-3
Dial-by-Name	1-3
# Dial Around.....	1-3
Logging Into Your Mailbox.....	1-3
Receptionist II Operation	1-4

Table of Contents

Call Flow and Call Processing	1-4
Typical Call Transfer.....	1-4
Leaving a Message	1-4
Screened Transfer	1-5
Caller Waits or Dials "0"	1-6
Converting an Extension Number to a Mailbox Number	1-7
Dialing an Extension	1-8
Mailbox Call Processing	1-9
Single-Digit Access Menus	1-9

2 Configuring Receptionist II

Parameter Groups	2-1
Receptionist II Call Processing Parameters	2-2
Dialing Plan Options	2-2
PBX Dialing Plan.....	2-2
Delete Digits Table and Offset Table.....	2-3
How Receptionist II Uses These Tables	2-5
Timeout for Receipt of First DTMF Digit.....	2-6
PBX Console Attendant Day/Night Access Code.....	2-6
Flow Options	2-7
Mailbox Message Prompt Greeting/Name	2-7
PBX Console Operation.....	2-8
PBX Dial String Definitions.....	2-8
Pre-Directory/Post-Directory Number Dial String.....	2-8
Connect Dial String on Called Party Accept	2-10
Dial String for Return on Called Party Refused.....	2-10
Dial String for Return on Called Party, Busy, or RNA.....	2-10
Special Actions on Reorder Tone Encountered	2-11
Default Settings for Pre-Programmed Dial Strings	2-12
Extension and Trunk Treatment Types for Mailboxes.....	2-13
Extension Treatment Type Parameters	2-13
Index Number.....	2-13
Index Name	2-13
Authorized Period(s)	2-14
Authorization Code.....	2-14
Screen Calls.....	2-14
Ring No Answer (RNA) Treatment	2-15
Busy Treatment.....	2-15

Reject Treatment.....	2-15
Redial Menu to Use	2-15
Default Extension Treatment Types.....	2-16
Trunk Treatment Types	2-17
Connect Criteria	2-17
Failure Treatment	2-18
Modifying or Creating Mailboxes	2-18
Mailbox-Receptionist II Interaction.....	2-18
Special Mailboxes for Single-Digit Access.....	2-19
Receptionist II Extensions.....	2-19
Receptionist II Worksheets	2-19
Worksheet 1	2-19
Worksheet 2.....	2-20
Worksheets 3 and 4.....	2-20
Task List and Procedures	

Worksheets

Index

List of Figures

Figure 1-1 Receptionist II Supervised Call Transfer.....	1-5
Figure 1-2 Call Screening by Receptionist II	1-6
Figure 1-3 Intermediate Attendant Call Flow	1-6
Figure 1-4 Extension-to-Mailbox Number Conversion	1-8
Figure 1-5 Single-Digit Access Menu Call Flow	1-9
Figure 2-1 Call Processing Menu Options.....	2-1
Figure 2-2 Offset Table.....	2-4

List of Tables

Table 2-1 Day/Night Access Codes.....	2-6
Table 2-2 Pre-Directory/Post-Directory Number Codes.....	2-9
Table 2-3 Default Values for PBX Dial String Groups.....	2-12
Table 2-4 Authorization Codes.....	2-14
Table 2-5 Ring No Answer Treatment Coding Choices.....	2-15
Table 2-6 Redial Menu Coding Choices.....	2-16
Table 2-7 Default Extension Treatment Types.....	2-17

About This Manual

This manual describes how to configure the Receptionist II software in any of the Centigram Series 6 Communications Servers:

- Model 640
- Model 120
- Model 70

Who Should Read This Manual

This manual is intended for technicians and administrators who are responsible for configuring the Receptionist II application on the Centigram Series 6 server.

How to Use This Manual

This manual contains detailed reference information, a list of tasks that you can perform, a collection of procedures for performing the tasks, and reader aids such as menu maps.

Reference Chapters



Use the material in Chapters 1 and 2 for detailed inquiry into the installation and configuration of Receptionist II in a Centigram Series 6 Communications Server. These chapters discuss how components are related, elaborates on concepts, gives operational details, and contains all necessary tables and figures about configuration. Use the *Centigram Series 6 Installation and Service Manual* appropriate for your platform for an actual server installation and the *VoiceMemo Reference and Configuration Manual* for VoiceMemo software configuration.

Task Lists



Task lists follow Reference chapters that include procedures. Use the task list, starting with a principal task (shown in **boldface**), to install and configure Receptionist II. Each task listed is described in more detail in a procedure. The task list is alphabetized, which helps most readers find the desired task (and procedure) quickly. No particular sequence of tasks is implied. The following example shows how a task list is organized:

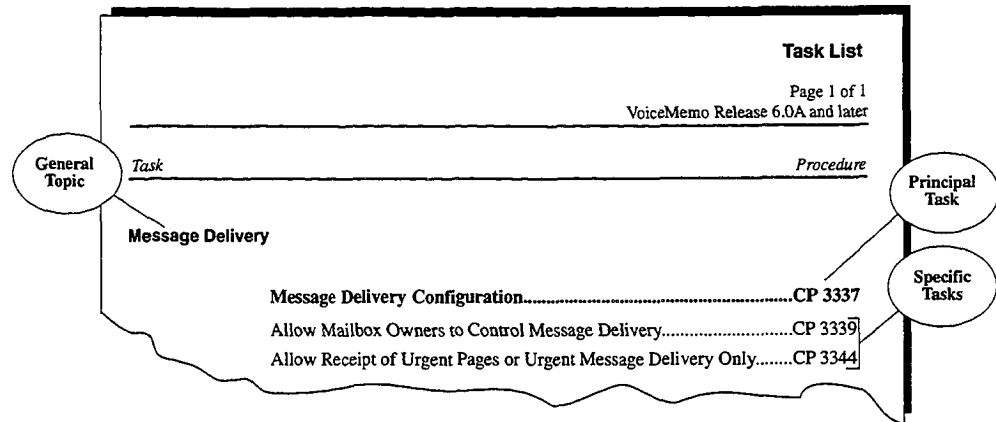

Procedures

Procedures follow the task list in the Reference chapter. Follow the steps in Centigram Procedures (CPs) to accomplish the desired tasks. Readers familiar with a Centigram Series 6 server can use the CPs as a checklist if desired, while readers new to a Centigram Series 6 server can use CPs for step-by-step instructions.

A reference column in each CP contains pointers, when necessary, to supplemental information such as another procedure, another manual, a technical reference, or a menu map.

Each CP is numbered for document identification and referencing; numbering does not indicate a sequence of performance. A numerical list of all CPs in this manual is also provided. It gives each CP's title, Chapter number, and which other procedures either call it or are called by it.

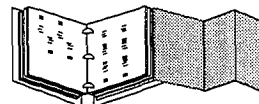

Menu Maps and Other Navigation Aids

Most of the documents in the new Centigram Series 6 document library have menu maps. You can refer to these document navigation aids at any point to help you reach a menu. And don't overlook the index; it is the fastest way to find all references to a specific topic.

Worksheets

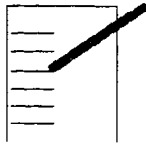

You will find blank worksheets in the back of this manual. Instructions for completing the worksheets are in the Reference chapters. Many of the CPs assume you have completed the appropriate worksheet.

Conventions Used in This Manual

The procedures in this manual use the following conventions to describe how you enter Receptionist II configuration information and how information is displayed on the Centigram Series 6 server console:

- Press Enter** Press the **Enter** key. For example, “Press **Enter** if the current number is correct.” On some keyboards, this key is labeled “Return” or has a return arrow (↵) on it.
- Enter** Type the text shown, then press the **Enter** key. For example, “Enter the line **number** (1-24)” means type a number from 1 through 24, and then press the **Enter** key.
- bold** Words or characters in bold type indicate either a value to be entered by you exactly as shown or, when used to indicate a variable entry, describe the type of value to be supplied by you. See example above.

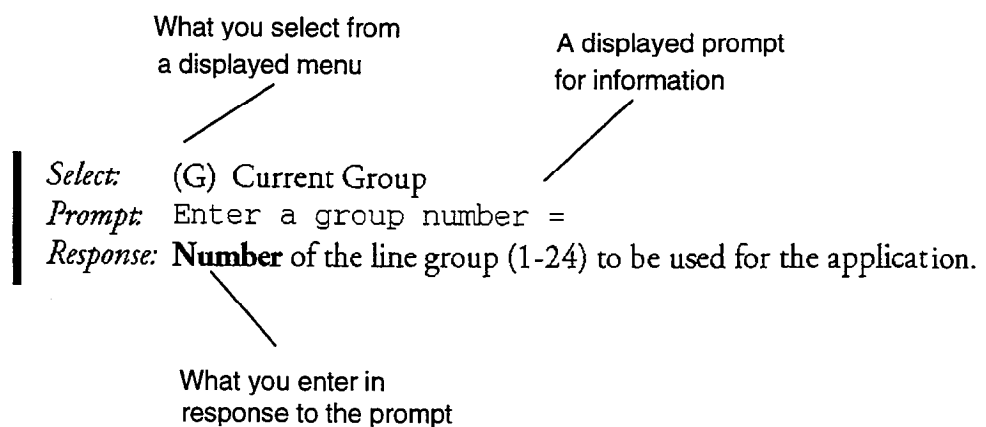

Note: Unless otherwise stated, press **Enter** after each response you enter.

Reader Advisories

Reader advisories used in this manual are shown below.

Note: Information especially useful in relation to this procedure.



CAUTION!

Information that helps you prevent equipment or software damage.



CAUTION!

Information that helps you avoid electrostatic discharge (ESD) damage to the equipment.



WARNING!

Information that helps you prevent an interruption to telecommunications traffic.



WARNING!

A hazard that can cause you personal injury.



DANGER!

Warns of a condition that could severely injure or kill you.

Before You Start

This manual assumes that you are familiar with using a console and keyboard. This section describes how to use the Centigram Series 6 server effectively.

Console Tips and Techniques

The tips and techniques offered in the following paragraphs can make configuration entry sessions at the Centigram Series 6 server maintenance console more productive.

Viewing Menus

- When you finish entering a value for a parameter, the server displays an abbreviated form of the current menu, called the “short menu.” To view the complete current menu when a short menu is displayed, just press **Enter**.
- To return to the Main Menu from any VoiceMemo application configuration menu, press **X** (Exit), until the Main Menu appears.

Accepting Defaults

- To accept a default displayed in a *prompt*, just press **Enter**.
- To accept a default displayed in a *menu*, no action is necessary.

Avoiding Automatic Exit



CAUTION!

The Centigram Series 6 server “times out” after 15 minutes. This means that if you do not enter anything at the console for 15 minutes, the server automatically exits from the current program. When this happens, all work that has not been saved on the disk is lost.

To avoid being timed out and losing your work, follow these steps:

1. When you need time to think, write down the name of the current menu.
2. Exit to the (server) Main Menu.
3. When you want to continue your work, enter the appropriate menu options to regain your place.

If you find that the Centigram Series 6 server has timed out, follow the steps below. If your screen is blank, press any key to reactivate the screen and then continue with these steps.

1. Press any key to start the login sequence.
2. Enter your user ID and password (if requested).
3. Starting from the Main Menu, enter menu options to proceed to the menu from which the server timed out.
4. Reenter data as needed to regain lost work.

Quitting an Entry Session

At any point during entry of offline or online parameters, you can quit. Quitting discards all parameter entries you have made and leaves the VoiceMemo application configuration the way it was before you started entering parameters.

To quit from the VoiceMemo Configuration Offline or Online Menu:

Select: (Q) Quit -- Forget Changes

Prompt: Quit and forget changes? (y/n) =

Response: Y to return to the VoiceMemo Configuration Main Menu.

Shortcut Commands

You can use the **Ctrl** (Control) key or the / (slash) key while simultaneously pressing another key to execute shortcut commands at an Centigram Series 6 server maintenance console.

To do this...	Type...
Activate a timed-out console.	any key
From the offline or online menus, or FCOS, LCOS, GCOS menus, return to the VoiceMemo Configuration Menu and save any entries.	/X
From the offline or online menus, or FCOS, LCOS, GCOS menus, return to the VoiceMemo Configuration Menu without saving any entries.	/Q Y
Stop scrolling a displayed report.	Ctrl-S
Resume scrolling a displayed report.	Ctrl-Q
Return to the VoiceMemo application when a # or \$ prompt is displayed.	Ctrl-D or type exit

1 Introduction

Receptionist II is a Centigram software product that functions as an automated attendant, typically, within an integrated Centigram Series 6 Communication Server and PBX system. Receptionist II can perform the following tasks:

- Pick up an incoming call and greet the caller
- Allow the caller to dial an extension
- Screen a call
- Connect the caller to an intermediate attendant (a person to screen calls or take messages)
- Transfer a caller to a voice mailbox

When a call comes in, Receptionist II takes the call, then transfers the call, as required. Receptionist II can make blind, supervised, or screened transfers.

- **Blind transfer.** The system releases the call (“hangs up”) after dialing the extension; used for transferring to extensions that do not have a mailbox on the system.
- **Supervised transfer.** The system stays online until the caller gets through to the desired extension. If the extension is busy or rings but does not answer—referred to as Ring No Answer (RNA) in the rest of this manual—Receptionist II pulls back the call and the caller can choose to leave a message in the called party's mailbox, or be transferred to another extension.
- **Screened transfer.** Receptionist II asks for the caller's name, then notifies the called party about the call and the called party can choose to accept or reject the call. Again, if the call is rejected, the caller can leave a message in the called party's mailbox or be transferred to another extension. The options available to a caller (transferring to another extension or leaving messages in mailboxes) are configured by the system administrator.

Receptionist II Features

Receptionist II has the features described in the following paragraphs.

Console Attendant Functions

Receptionist II can answer incoming calls, screen them, dial an extension for the caller, or play menu options for the caller.

Receptionist II can also allow direct access to an extension directly and/or call forwarding to a mailbox without Receptionist II assistance.

Day/Night Greetings

You can record separate customized greetings for day answering and night answering. You can configure hours and days that comprise "Day" and "Night/Weekend" to suit the requirements of the individual installation. Receptionist II can handle "day" calls differently from "night" calls.

Configurable Prompts Languages

System prompts are available in English (American, Australian, New Zealand, UK), French, German, Japanese, Korean, Mandarin, Spanish, Mexican Spanish, and Portuguese.

Automatic Outdialing to Trunks

When callers dial an internal extension number, Receptionist II can automatically route the call to an outside number (for example, a modem number).

Call Screening/Automatic Announcement for Users

Mailbox users can choose to have all their calls screened. A mailbox user who calls another mailbox user can press the star (*) key, plus his or her own mailbox number, in reply to the prompt "Whom may I say is calling?" Receptionist II automatically announces the name that is recorded in the mailbox. If the call is not answered (or is rejected by the user), any message that is left is recorded from the caller's mailbox. This allows the recipient to answer the message simply by pressing the 2, or A (for answer), key.

Flexible Rerouting of Calls

When a call does not go through, users can have their calls routed to a personal attendant's number, to the Console Attendant, or to their personal mailboxes; or they can choose to have Receptionist II play one of four redial menus. You

can choose different routings for Busy, Ring No Answer, and Rejected calls (for calls to extensions), and call failure (for calls to trunks).

Customized Treatments for Individual Users

You can group together call processing options to make up to 16 “treatment types,” or call processing instructions, that allow an administrator to provide users with the call processing options that they want. Treatment types are stored in the mailbox data file, and the administrator can easily change a treatment type.

Separate Day and Night/Weekend Call Treatments for Individual Users

Each mailbox can store separate Day and Night/Weekend treatment types. Receptionist II checks the user’s mailbox for the correct treatment type before processing an incoming call.

Directory/Menu Capabilities

You can use mailboxes with “tree” class of service to build directories or menus which direct outside callers to the appropriate extension or mailbox within the system. The tree mailbox can allow the user to access a “chain” mailbox, which plays a mailbox greeting, then prompts the caller to enter an extension number.

Single-Digit Access

You can configure this menu capability so that after the main greeting plays, Receptionist II allows single-digit access to selected departments and specific extensions.

Dial-by-Name

Receptionist II can allow users to reach an extension by pressing keys that spell a person’s name. You can configure the feature so that the caller can dial by last name or first name dial by last name or first name.

Dial Around

The # **dial around** feature allows the caller to act as his/her own receptionist. For example, after leaving a message for one user, the caller can press **#**, then dial another number when prompted.

Logging Into Your Mailbox

Receptionist II is a layer of programming that functions on top of the VoiceMemo application. If you call a number answered by Receptionist II, you can dial an extension. In addition, you can reach the VoiceMemo message

center by pressing **#** to leave a message in a mailbox. You can also log into your mailbox from the VoiceMemo message center by pressing **#** again, followed by your mailbox number; alternatively, you can dial your mailbox number, followed by **#** to log into the mailbox.

Receptionist II Operation

The system administrator configures how Receptionist II initially answers a call. The administrator then enters call processing instructions for individual mailboxes. Receptionist II checks these instructions when directing a call to the mailbox and handles the call according to these instructions.

Call Flow and Call Processing

Figures 1-1 to 1-5 show the basic Receptionist II call flow and call processing.

Typical Call Transfer

Figure 1 shows a typical call flow for a call transfer to a called party. A caller dials the company main number, Receptionist picks up the call and greets the caller, then asks the caller to dial an extension. The caller dials the extension. Receptionist II then transfers the call. Typically Receptionist II supervises the transfer—Receptionist II on the line until the called party answers the phone, then releases the call (hangs up).

If the extension has no associated mailbox, Receptionist II releases the call as soon as the caller dials the extension.

Leaving a Message

Receptionist II allows the user to dial an extension. If the called party is not available, Receptionist II gives the caller an option to leave a message. Figure 1-1 shows this call flow.

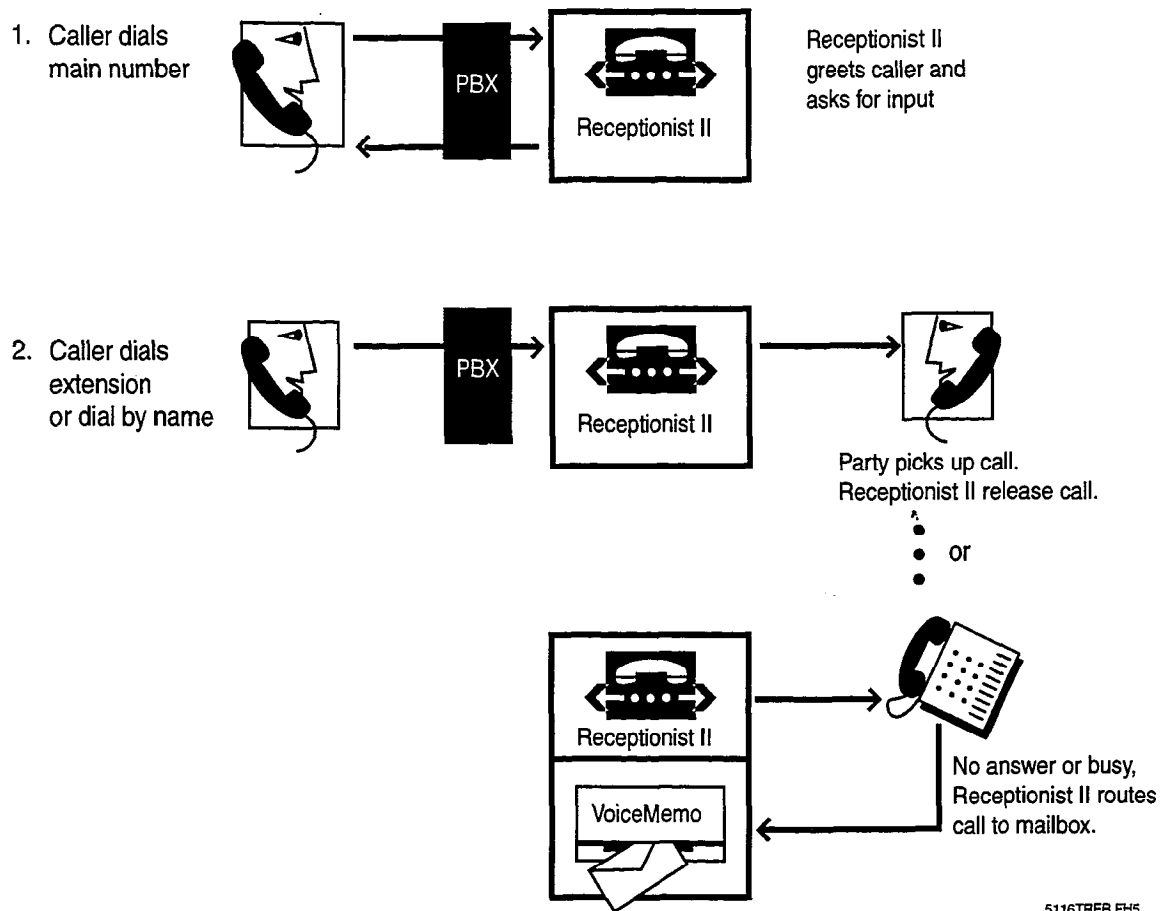
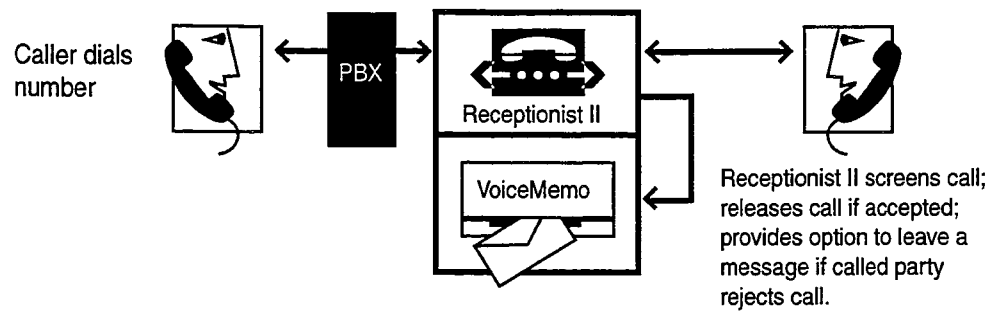

Figure 1-1 Receptionist II Supervised Call Transfer

Screened Transfer

Receptionist II asks the caller for his/her name, then notifies the called party about the call and the called party can choose to accept or reject the call. Again, if the call is rejected, the caller can leave a message in the called party's mailbox or be transferred to another extension. The options available to a caller (transferring to another extension or leaving messages in mailboxes) are configured by the system administrator. Figure 1-2 illustrates call screening.



5117scrn.FH5

Figure 1-2 Call Screening by Receptionist II

You can configure Receptionist II to process a call through an intermediate attendant. Receptionist II dials the intermediate attendant, who screens the call. Figure 1-3 shows the intermediate attendant call flow.

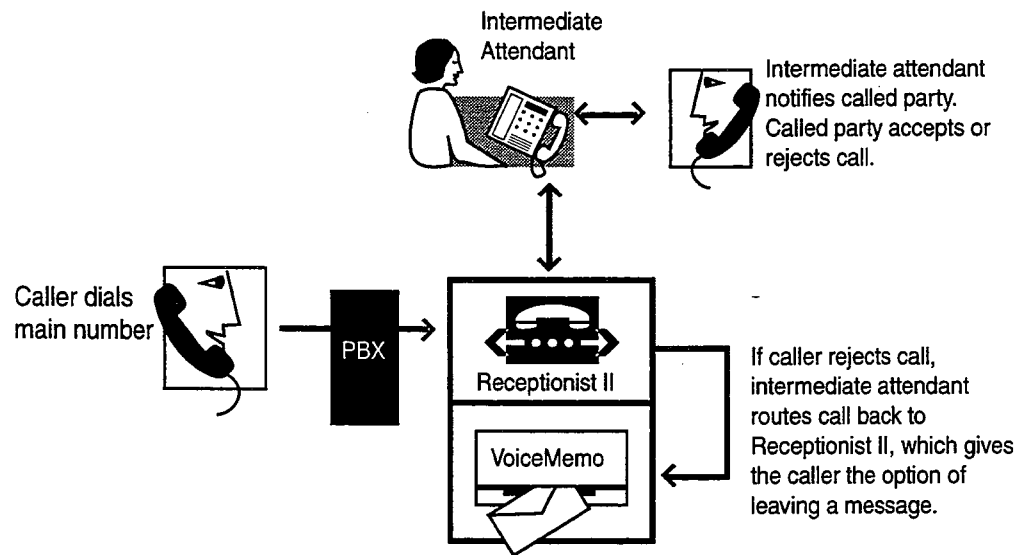

5118attn.fh5

Figure 1-3 Intermediate Attendant Call Flow

Caller Waits or Dials "0"

If the system allows the caller to reach a person (for example, a console attendant) the caller reaches the person by dialing 0 or waiting, rather than dialing an extension.

Converting an Extension Number to a Mailbox Number

When a caller dials an extension, Receptionist II converts the extension number to the associated mailbox number, checks the mailbox for instructions, then dials the extension or trunk number that is stored in the mailbox.

If the mailbox numbers are the same as the extension numbers, then Receptionist II can simply check whether the extension has an associated mailbox. However, a system might require Receptionist II to convert an extension number-to-mailbox number using the following steps, in the order shown:

1. Delete leading digits, if applicable.
2. Add signed value in offset table, if applicable.

Example

Extension: **3975**

For all extensions starting with 3, delete 1 digit

Leading digit deleted: **975**

For all extensions starting with "3," the offset value is -100

Add signed offset value to 975: $975 + (-100)$

Mailbox number is **875**

For more detailed information on Delete Digit and Offset tables, see Chapter 2, "Receptionist II Parameters." The flowchart in Figure 1-4 shows extension-to-mailbox number conversion.

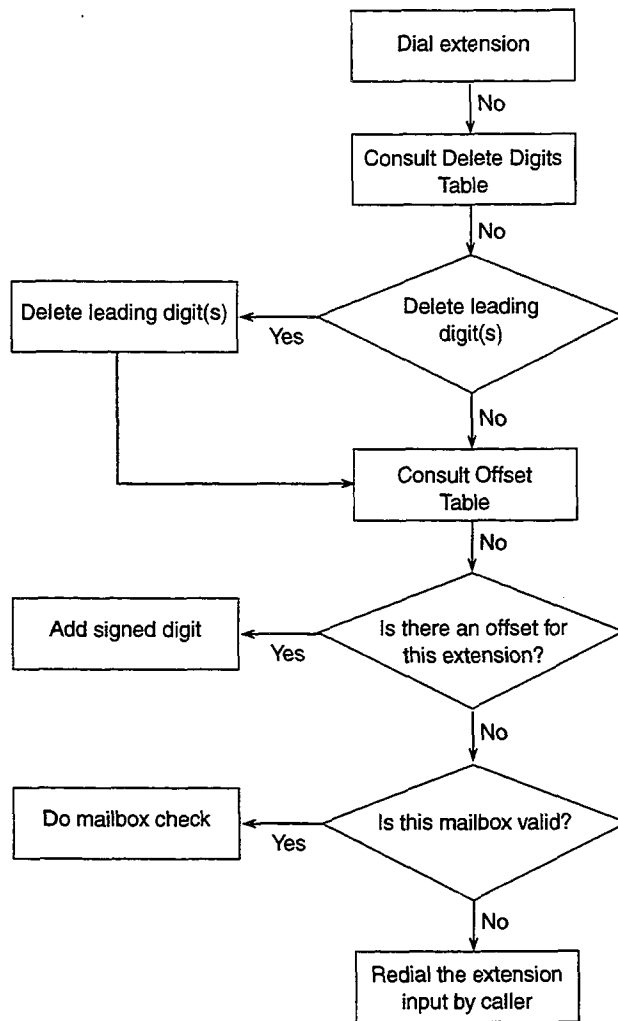

5120 conv.fh5

Figure 1-4 Extension-to-Mailbox Number Conversion

Dialing an Extension

After Receptionist II validates an extension number and its associated mailbox, Receptionist II dials the extension number. If screening is not in place, the caller will pick up the call or Receptionist II will fail to connect the call because of one of the following situations:

- Reorder tone – fast busy tone indicating that switching paths are busy. Depending on the PBX specifications, Receptionist II is configured to treat the reorder tone as one of the following situations:
 - Dead line

- Busy
- Ring No Answer

The administrator can configure the Receptionist II response, which can take the caller to an attendant, allow the caller to dial another extension, leave a message, or select from a menu that lists the options just mentioned.

Mailbox Call Processing

Each mailbox stores call processing instructions. To simplify mailbox programming, the administrator can enter up to 16 groups of call processing instructions, or treatment types, into the system configuration file. When creating a mailbox, an administrator can use these treatment types to configure separate day and night instructions that best match the choices of the mailbox owner.

Single-Digit Access Menus

You can configure Receptionist II to present the caller with a menu of options that the caller can access by pressing a single digit. For example, Receptionist II might greet the caller as follows: "Thank you for calling ABC company. Press 1 to dial an extension, press 2 to reach Technical Support, press 3 to reach the Job Hotline." Figure 1-5 illustrates the call flow for this sample single-digit menu.

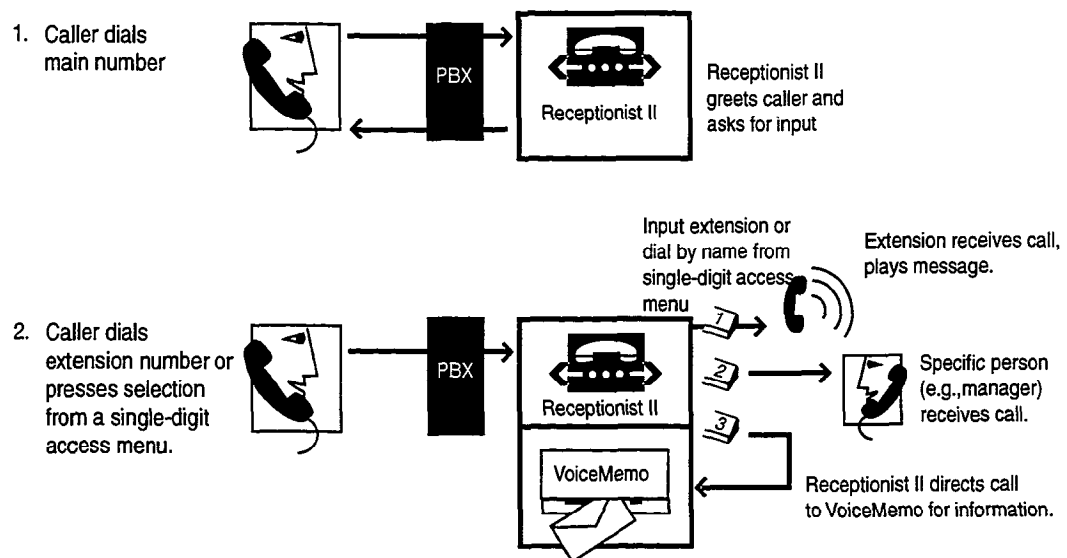

5110dgt.FH5

Figure 1-5 Single-Digit Access Menu Call Flow

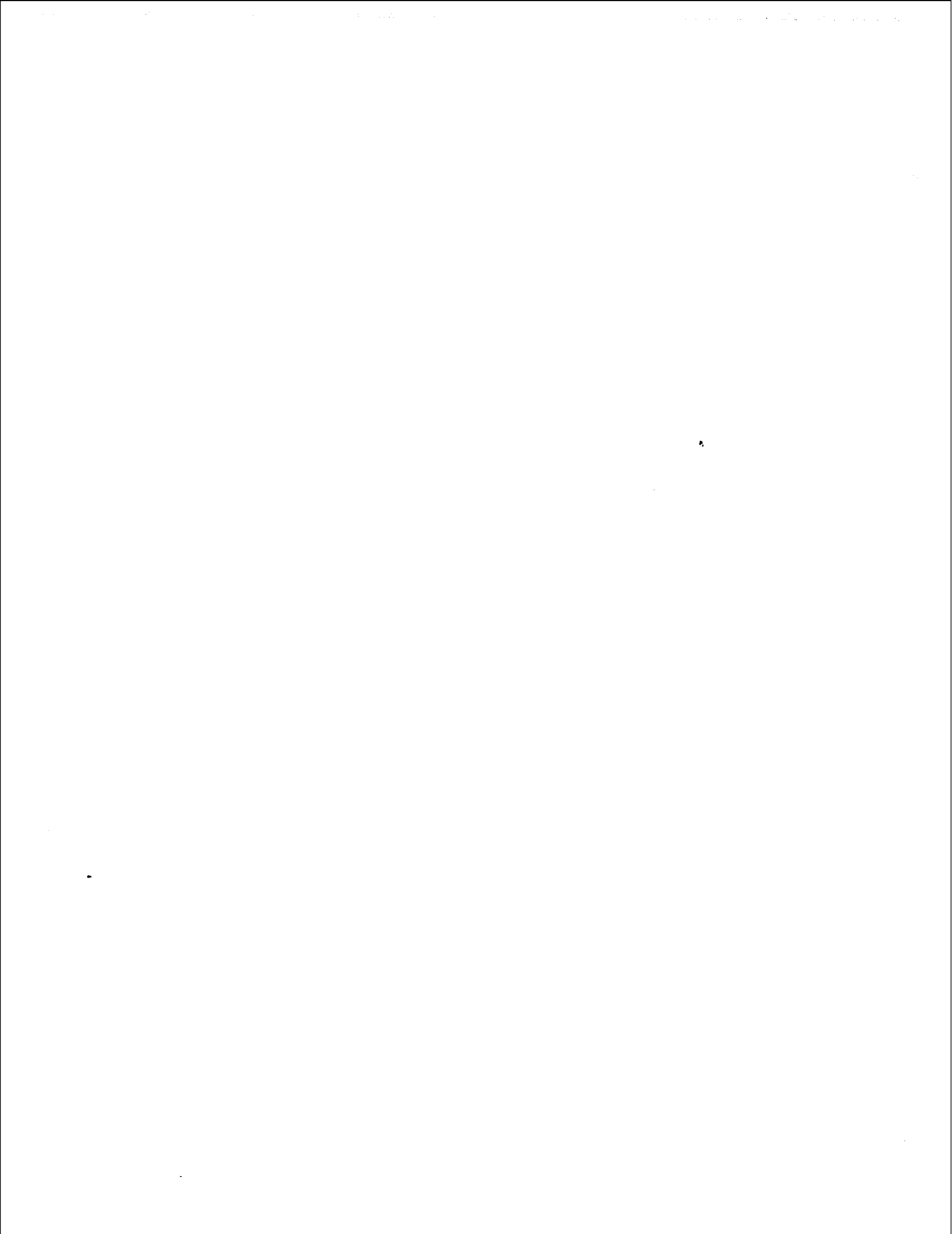

2 Configuring Receptionist II

Typically, Receptionist II functions as a layer of programming within an integrated system. This means that you assign a line group to the integration software and configure Receptionist II parameters within the same line group. Occasionally, an integration might require that you configure Receptionist II separately from the application. In this case, as in an in-band integration, the integration instructions direct you to assign Receptionist II to a separate line group. In either case, the Receptionist II configuration parameters are the same, whether you reach the Receptionist Menu through the integration software line group or through a line group specifically assigned to Receptionist II.

Parameter Groups

Receptionist II instructions, or parameter values, fall into three main groups.

- Line group assignment: index number, name, and number of lines in the line group. For information on line groups, refer to the *VoiceMemo Reference and Configuration Manual*.
- Messaging functions, or the handling of greetings and messages from callers. The line group uses the same information that is provided for the VoiceMemo application, which are discussed in the *VoiceMemo Reference and Configuration Manual*.
- Receptionist II call processing functions: The administrator sets call processing instructions for Receptionist II in the Receptionist Menu shown in Figure 2-1. Instructions on reaching this menu are in the procedures section of this chapter, following the discussion of call-processing parameters.

Receptionist

```
-----  
(D) Dialing Plan Options  
(F) Flow Options  
(P) PBX Dial String Definitions  
(T) Trunk / Extension Treatment Types
```

Figure 2-1 Call Processing Menu Options

Receptionist II Call Processing Parameters

This section discusses the parameters shown in Figure 2-1.

Dialing Plan Options

This section discusses the dialing plan for the automated attendant functions of Receptionist II. If Receptionist II is integrated with the PBX system, then this dialing plan must match the PBX dialing plan.

The mailbox dialing plan for messaging functions is discussed in the *VoiceMemo Reference and Configuration Manual*.

- (P) Dialing Plan = [4,4,4,4,4,4,0,0]
- (D) Delete Digits = [0,0,0,0,0,0,0,0]
- (F) Offset Table
- (T) Timeout for Receipt of First Digit (.1 seconds) = [0]
- (Y) PBX Console Attendant Day Access Code = [0H]
- (Z) PBX Console Attendant Night Access Code = [0H]

PBX Dialing Plan

The dialing plan controls the extension numbers that an outside caller dials to reach a user. A caller reaching Receptionist II hears the prompt, "Please enter an extension number, or wait for assistance." When the caller enters a number, Receptionist II checks the input against the PBX dialing plan.

If the number conforms to the PBX dialing plan, Receptionist II proceeds to delete any leading digits and add any offsets that are specified (see "Delete Digits Table and Offset Table" later in this chapter). Receptionist II then checks the mailbox dialing plan.

If the result is a valid mailbox number, Receptionist II checks the mailbox data file, and dials the "Mailbox's Extension Number" set up by the administrator. The call is then processed according to the instructions configured for that mailbox.

If the result is not a valid extension, Receptionist II dials the number that was originally input by the caller, then hangs up.

The dialing plan is a string of nine numbers. The first number in the string shows the number of digits allowed for extensions that begin with 1. Each number that follows gives the number of digits allowed for extensions that begin with 2 through 9.

A "V" at any position indicates that the number of allowable digits (can have up to eleven) for that position is variable; Receptionist II accepts any extension input with

that particular leading digit. The system uses a three-second timeout to determine when input is finished.

Dialing Plan Example

0,4,3,3,3,A,V,0,0

The values indicate the number of digits allowed for extensions starting with digits 1 through 9. The sample dialing plan is interpreted as follows, for extensions that begin with the numbers listed:

- 1—no extensions starting with “1”
- 2—must have four digits (for example, 2112)
- 3 through 5—must have three digits (for example, 303, 415, 504)
- 6—“A” makes “6” the dial-by-name access digit
- 7— the number of digits is variable (for example, 798, 7734, 765379)
- 8 and 9—no extensions start with 8 or 9

If the PBX dialing plan is 3,3,3,3,3,3,0,0, all extensions that begin with digits 1 through 7 must have three digits. No extensions start with the digits 8 or 9. This disallows pressing 8 or 9 to dial out from Receptionist II; in addition, the Administrator mailbox number (default, 998) and Attendant mailbox number (default, 999) cannot be reached from Receptionist II.

Delete Digits Table and Offset Table

Ideally, extension numbers are identical to the mailbox numbers within a system. For instances where they do not match, Receptionist II must convert extension numbers to mailbox numbers, using values contained the Delete Digits Table and the Offset Table.

Delete Digits Table

The delete digits table is a string of numbers that represent, from left to right, extension numbers that begin with 1 through 9. The number shown at each position indicates the number of digits that Receptionist II must delete from an extension to convert it to a mailbox number.

The digits are deleted in the order received. For example, if the number in the Delete Digits table is 2, Receptionist II deletes the first two digits that it receives.

Example

If the delete digits table is 0,0,0,1,0,0,0,3,0

- No leading digits are deleted from extensions that begin with 1, 2, or 3 (that is, they are unchanged)
- One leading digit is deleted from all extensions that begin with 4 (for example, 4657 becomes 657)
- Extensions that begin with 5, 6, or 7 are unchanged
- Three leading digits are deleted from extensions that begin with 8 (for example, 8657 becomes 657)
- Extensions that begin with 9 are unchanged

The default Delete Digits table is 0,0,0,0,0,0,0,0, which means that all extension numbers are passed through unchanged. If you need to make changes to this table, record the new table on Receptionist II Worksheet 2 at the end of this chapter.

Offset Table

To complete the conversion of an extension number to a mailbox number, Receptionist II can add an offset after deleting any leading digits. The offset can be positive or negative. Offset tables are numbered 1 through 9. The default values for each offset table is 0, as shown in Figure 2-2. The table number refers to the leading digit of the extension number **before** any digits are deleted. Table 1 shows the offset to be added to extensions that begin with 1. If the extension is 1678, the offset value read is the one in Table 1, even if during the conversion, the leading digit might be deleted); Table 2 specifies the offsets for extensions that begin with 2; and so on.

OFFSET: s
Table offset for #1 = [0]
Table offset for #2 = [0]
Table offset for #3 = [0]
Table offset for #4 = [0]
Table offset for #5 = [0]
Table offset for #6 = [0]
Table offset for #7 = [0]
Table offset for #8 = [0]
Table offset for #9 = [0]

Figure 2-2 Offset Table

Example

For example, if the offset value for Table 5 is +25, the mailbox number for extension 560 (+25) is 585.

How Receptionist II Uses These Tables

The following examples show the process of transforming extension numbers to mailbox numbers:

Example 1

Assume

Delete Digits = 0,0,1,0,0,2,0,0,0
Table offset for #3 = -50

This means that Receptionist II transforms an extension that begins with 3 to a mailbox number using the following procedure:

3275 (extension that was entered)
275 (delete one leading digit)
-50 (add signed offset from Table 3)
225 (mailbox number)

Under the same circumstances, extension "3276" is converted to mailbox number 226, "3280" is converted to mailbox number 230, etc.

Example 2

Assume

Delete Digits = 0,0,0,0,0,0,0,0,0
Table offset for #1 = 200

This means that any extension number that begins with 1 maps as follows:

17 (extension that was entered)
- (do not delete any leading digits)
+200 (add signed offset from Table 1)
217 (mailbox number)

Timeout for Receipt of First DTMF Digit

This is a timing parameter that the administrator can configure to allow a pause before Receptionist II starts processing digits that a caller dials. The default timeout value is 0, indicating that the feature is turned off. The timeout value is a number between 0 and 50 in tenths of a second.

PBX Console Attendant Day/Night Access Code

The PBX console attendant day and night access codes usually contain a system attendant number to which a caller is transferred during the configured time period.

Receptionist II dials the appropriate string for the time period under the following circumstances:

- A caller waits for assistance before dialing an extension.
- A call fails to go through after the caller has entered an extension, assistance is required, and there is no attendant's extension number in the mailbox data file.

Console access codes are PBX-dependent, and can be determined by actually transferring a call to the operator from a station set. Table 2-1 shows the coding choices available.

Table 2-1 Day/Night Access Codes

Code	Meaning
0-9, *, #	Numbers and characters on a standard DTMF keypad
A through D	Fourth column DTMF keys
(Start pulse dialing
)	Stop pulse dialing; resume tone dialing
T	Wait for dial tone
S	Switch hook flash
F	Switch hook flash and wait for dial tone
+	Pause one second
H	Hang up (go on-hook)

Note: Do not program a G (wait for greeting) into a PBX Console Attendant Day or Night Access Code, or into the Pre-DN string or Post-DN string; internal Receptionist II programming does not allow a successful transfer if a G appears in any of these strings.

The default dial string is "0H," for both the PBX Console Attendant Day Access Code and the PBX Console Attendant Night Access Code. This string means "issue DTMF zero, then hang up." For most PBXs, this is sufficient to transfer the call to the Attendant.

The Receptionist II day or night dialing access code proceeds in the following sequence:

- Execute the Pre Directory Number (Pre-DN) dial string that is set under “PBX Dial String Definitions”; the Pre-DN string usually contains all the instructions for the transfer.
- Dial the appropriate PBX console attendant access code
- Execute the Post Directory Number (Post-DN) string, then wait for a greeting (Receptionist II programming always appends a G to the end of the Post-DN string after a PBX Console Attendant Access Code has been dialed).

The default day and night console access codes are blind transfers, which are available only if the PBX allows a blind transfer to the operator. A blind transfer means Receptionist II releases the call before the greeting starts. Instructing Receptionist II to release the call after dialing the number ensures that the PBX does not continue the transfer when the caller has decided to hang up.

If there is no PBX console attendant during the day, or during night/weekend hours, entering a period deletes the access code for that time period. When there is no access code, the caller who “waits” (in response to the prompt, “Please enter a mailbox number or wait”) is prompted to leave a message in the attendant’s mailbox. (Receptionist II thanks the caller and hangs up if the attendant’s mailbox has also been deleted.)

Flow Options

The Flow Options parameters contain information on how Receptionist II is to handle given calls.

Mailbox Message Prompt Greeting/Name

The Mailbox Message Prompt value determines what message the caller hears if the called party is not available. If the default value of G, for greeting, is chosen, the caller hears the mailbox owner’s personal greeting. If N, for Name, is chosen, the caller hears the prompt, “Please leave a message for [name recorded in mailbox].” (If no name was recorded for the mailbox, the caller hears, “Please leave a message for [mailbox number].”)

PBX Console Operation

PBX Console Operation provides the option to specify that the initial welcome greeting be replaced by a short dial tone to prompt the operator that Receptionist II is ready to receive the extension number.

PBX Console Operation is set to the default value of N when normal Receptionist II call processing is desired.



CAUTION!

Do not change the default unless you specifically want to replace greetings with a short dial tone.

PBX Dial String Definitions

Receptionist II simulates the actions of a human console attendant. Since different PBX's have different console operator protocols, certain coding must be entered into the Receptionist II configuration file to tell Receptionist II how to process calls under all the possible conditions, using signals understood by the PBX.

Pre-programmed dial strings for eleven different PBXs: ROLM CBX, Northern Telecom SL-1, AT&T Dimension, Mitel SX, AT&T System 75/85, NEC 2400, Centrex, Fujitsu Focus, Hitachi DX, Telex 1001, and Siemens Saturn can be selected from the Online Configuration Menu . If the PBX at the installation site is not shown on the menu, the dial strings must be programmed in the Default PBX Options Menu.

The easiest way to determine the proper coding for each dial string is to attach phone sets to three PBX extensions, one for the "caller," one for the "called party," and one for simulating the actions of the PBX console operator, then follow the steps that are given in the descriptions below.

Pre-Directory/Post-Directory Number Dial String

The "directory number" in the Pre-Directory/Post-Directory Number Dial String refers to the extension number associated with a mailbox number. The Pre-Directory Number Dial String puts the caller on hold so VoiceMemo can dial the PBX attendant. The Post-Directory Number Dial String is the number or letter code that Receptionist II dials after the extension has been dialed. Table 2-2 shows Pre-Directory/Post-Directory Number coding choices.

Table 2-2 Pre-Directory/Post-Directory Number Codes

Code	Meaning
0-9, *, #	Numbers and characters on a standard DTMF keypad
A through D	Fourth column DTMF keys
(Start pulse dialing
)	Stop pulse dialing; resume tone dialing
T	Wait for dial tone
S	Switch hook flash
F	Switch hook flash and wait for dial tone
+	Pause one second
H	Hang up (go on-hook)

Pre-Directory Number Dial String

The default Pre Directory Number (Pre-DN) dial string is "S+," which tells the PBX to do a Switch hook flash, then wait one second before dialing the extension number (which may be a trunk number) that is in the mailbox. (Remember that Receptionist II uses the Delete Digits table, and the Offset Table to transform the extension that is input by the caller into a mailbox number, and then dials the extension number that is stored in the mailbox's data file.)

The Pre-DN string is also used with Receptionist II Console Access Codes. **Before** the appropriate Console Access Code is dialed, Receptionist II executes the Pre-DN string, then waits for the internally programmed greeting to be played.

Note: Do not program a G (wait for greeting) into the Pre-DN string; internal Receptionist II programming does not allow a successful transfer to the console attendant if a G appears in this string.

Post Directory Number Dial String

The default Post Directory Number (Post-DN) dial string is "+," which tells Receptionist II to wait one second before taking any other action. This gives the PBX enough time to make the connection to the extension. If no Post -DN dial string is needed, enter a period.

The Post-DN string is also used with Receptionist II Console Access Codes. **After** the appropriate Console Access Code has been dialed, Receptionist II executes the Post-DN string, then waits for the internally programmed greeting to be played.

Note: Do not program a G (wait for greeting) or a T (wait for dial tone) into the Post-DN string; internal Receptionist II programming does not allow a successful transfer to the console attendant if a G or T appears in this string.

When an H appears in the Post-DN string, every call that Receptionist II makes is a blind transfer. Receptionist II transfers the call without invoking treatment types, connect strings, or return strings.

Connect Dial String on Called Party Accept

Receptionist II uses this dial string to connect a caller with the called party in the following situations:

- When call screening is not configured for the extension dialed
- When there is no mailbox associated with the extension dialed
- When a mailbox is configured for call screening, and the call is answered and accepted by the called party

There is no default for Connect Dial String on Called Party Accept, since the automatic release is usually sufficient to connect the caller with the called party. If a dial string is entered, but later it is necessary to reset the value to “no string,” entering a period erases the dial string.

Dial String for Return on Called Party Refused

This dial string is used to reconnect to the caller when call screening is in effect and Receptionist II has successfully connected with the extension, but the called party has refused the call. The default Dial String for Return on Called Party Refused is “++,” which tells Receptionist II to wait two seconds before doing anything else. The two second delay gives the called party time to hang up his/her phone. For most PBXs, this action is sufficient to reconnect the caller with Receptionist II. If no dial string is needed, enter a period.

Dial String for Return on Called Party, Busy, or RNA

When Receptionist II dials an extension, and the call does not go through because a busy or reorder tone is encountered, or because there is no answer, or because silence on the line indicates that the extension number is not valid, the Dial String for Return on Called Party Busy or RNA is used to tell the PBX to reconnect Receptionist II with the caller. The default dial string is “S+,” which means that Receptionist II issues a switch hook flash, and then waits one second before doing anything else. If no dial string is needed, enter a period.

Special Actions on Reorder Tone Encountered

This dial string tells Receptionist II what to do when an extension is dialed, and a reorder tone is encountered.

- Some PBXs return a reorder tone when an extension is set to “Do Not Disturb.” If Receptionist II is integrated with this type of PBX, enter “R” for the Special Actions on Reorder Tone Encountered dial string. When Receptionist II receives a reorder tone, it returns to the caller, says “I’m sorry, [called party’s name] did not answer,” then follows the RNA treatment of the called party’s mailbox.
- A dial string can be entered to direct the call to an assistance number, or to a number where the caller can report that the extension is malfunctioning.
- If no string is found here, Receptionist II treats the call like a dead line: the Dial String for Return on Failure to Connect is dialed and the caller is told, “That is not a valid extension number. Please enter another extension number.”

There is no default Special Actions on Reorder Tone Encountered dial string. If a dial string is entered, but later it is necessary to reset the value to “no string,” enter a period to erase the dial string.

Default Settings for Pre-Programmed Dial Strings

Table 2-3 lists the default values in the Default menu and the default values for each dial string group that is pre-programmed for a specific PBX. These settings can be modified.

Table 2-3 Default Values for PBX Dial String Groups

Option	Default	ROLM CBX	NT SL-1	ATT Dim.	Mitel SX	NEC 2400	Centrex	Fujitsu Focus	Hitachi i DX	Telex . 1001	Siem. Saturn
(A) Post Directory number dial string	+h	++	+	+	+	+	+	+	+	+	+
(B) Pre Directory number dial string / Attendant xfer string	S+	S+*7	S+	S+	S+	S++	S+++	F1+	S+	F33	S+
(E) Dial string for Return on Called Party Refused	++	S+*1	++	++	++	++	++	++	++	F30	++
(F) Dial string for Return on Called Party Busy	S+	S+	S+	S+	S+	S+	S+	S+	S+	S+	S+
(G) Special actions on Reorder Tone Encountered	OH	R				R			R		OH
(H) Dial string for Return on Called Party RNA	S+	S+*1	S++	S+	S++	S++	S+S+	S++	S++	F30	S+

Extension and Trunk Treatment Types for Mailboxes

“Treatment types” are instructions to Receptionist II for processing calls to mailboxes. Treatment types are configured for each mailbox that uses Receptionist II. If no treatment type is configured, the Receptionist II default treatment is to play the mailbox greeting.

Treatment types are either extension or trunk. Receptionist II offers 16 extension and trunk treatment types, ten of which are defaults. The administrator can configure six additional treatments.

- An Extension treatment type provides instructions for processing incoming calls to mailboxes. The Extension treatment type specifies whether or not Receptionist II should screen calls; menus options to play/actions to take (1) when the extension rings, but there is no answer; (2) when the extension is busy; and (3) when a screened call is rejected by the called party.
- A Trunk treatment type provides instructions for processing mailboxes dialing numbers that are not answered by a person (long distance calls in zones that do not require a “1” to initiate the call, for example). When the number is dialed, Receptionist II either receives a response that indicates that the connect criteria have been met or failure to connect. When it receives a failure to connect response, Receptionist II then proceeds with the specified failure treatment.

Extension Treatment Type Parameters

This section describes extension type parameters.

Index Number

Each treatment type is represented by an index number. When creating/modifying a mailbox, the Administrator enters this number to select the treatment type.

Index Name

Each treatment type has an index name that corresponds to an index number. To be useful, index names should adequately describe the treatment type. For example, an extension treatment type that screens calls and plays redial menu M for all failure conditions (Busy, RNA, Rejected) could be named “screening/redial M.” Up to 24 characters are allowed for each index name.

When creating a mailbox, the Administrator is prompted for day and night treatment types. The online help text for these treatment types is a display of index numbers, followed by the corresponding index names. For example, the ten default treatment types have index numbers 1 to 10, and their names are Treatment 1,

Treatment 2, and so on (see Table 2-1). The administrator can give more descriptive names to the default or new treatment types.

Authorized Period(s)

The authorized period restricts access to a mailbox and to its associated extension/trunk number to a certain time period, such as daytime hours only. The default authorized period is A (all). Other selections are D (day only) or N (night/weekend only). Callers who try to access an extension at a time that is not within the authorized period hear the message "I'm sorry, that number is not available for access at this time." You set day/night hours in the Day/Night Menu.

This selection is not used for ordinary day/night treatment variations. The Administrator can select different day and night/weekend treatment types to provide these variations.

Authorization Code

An authorization code requires that every caller enter this code to access the extension or trunk that has this treatment type. An authorization code is used only for special circumstances, such as to restrict access to a modem, or to a WATS line.

Table 2-4 shows the characters that you can use in any combination within an authorization code.

Table 2-4 Authorization Codes

Code	Meaning
0 through 9, *, #	Keys on an ordinary pushbutton telephone
A through D	Fourth-column DTMF keys on special telephones
M	The caller can gain access by entering any valid mailbox number.
P	The caller must input a valid mailbox number and its corresponding passcode

Up to 10 characters are allowed for each authorization code. The default value is "blank" (no authorization code needed).

Screen Calls

This parameter applies to Extension Treatment Types only. When instructed to screen calls, Receptionist II asks every caller for his or her name, then puts the caller on hold, calls the desired extension, announces the name, and gives the called party

the opportunity to accept or reject the call. The default value is Y (yes). Entering N disables this feature.

Ring No Answer (RNA) Treatment

The Ring No Answer (RNA) treatment tells Receptionist II what to do when an extension rings, but no one answers it. This parameter applies to Extension Treatment Types only. Table 2-5 shows the code choices for the RNA treatment.

Table 2-5 Ring No Answer Treatment Coding Choices

Code	Meaning
A	Caller is transferred to the Attendant's extension number that is stored in the mailbox data file. If no Attendant's extension number has been specified, the caller is transferred to the Console Attendant.
M	Caller is prompted to leave a message in the called party's mailbox.
R	The redial menu that is selected under "Default Treatment on RNA and Busy Calls" is played, and Receptionist II follows the caller's instructions.

The default value is R.

Note: If the Attendant's extension number does not terminate in an "H" (for hang up), and the call to the Attendant's number does not complete (due to Busy, RNA, Rejected, or Failure condition), then Receptionist II looks at the Attendant's extension failure condition and follows the failure treatment that is specified for the extension originally called.

Busy Treatment

The Busy treatment tells Receptionist II what to do with incoming calls when the extension is busy. Choices are the same as for the RNA treatment. This parameter applies to Extension Treatment Types only.

Reject Treatment

The Reject treatment tells Receptionist II what to do with screened calls that are rejected by the called party. Choices are the same as for the RNA treatment. If R is chosen, be sure to set the "Redial Menu to Use" (see the next section) to a selection other than R. This parameter applies to Extension Treatment Types only.

Redial Menu to Use

This parameter applies to Extension Treatment Types only. When "R" (redial) is selected as the treatment for any of the failure conditions (RNA, Busy, or Reject),

and the caller simply waits, the Redial Menu to Use offers the following options: R (redial), M (message), A (assistance) and D (disconnect). The default value is M. Table 2-6 shows the text of each redial menu.

Table 2-6 Redial Menu Coding Choices

Code	Meaning
R	Press zero for assistance Press star (*) to hold for [called party's name]; the system rings the extension again every 10 seconds, but does continuously monitor the line Enter another extension number or wait to leave a message
M	Enter another extension number Press zero to return to the Attendant or wait to leave a message
D	Press star (*) to leave a message, zero to return to the Attendant, or enter another extension number.
A	Press star (*) to leave a message, enter another extension number, or wait for assistance

Receptionist II hangs up after 3 tries.

Note: Administrators may choose only one redial menu for each treatment type; any failure condition where Redial is specified (Busy, RNA, Reject) causes Receptionist II to play the same redial menu.

Redial menu R is not a suitable treatment for RNA or rejected calls, since a user who rejects a call does not want the caller to instruct Receptionist II to continually redial his or her number. When selecting a Redial Menu to Use for RNA and Reject Treatments, M (Force to Mailbox) or A (Force to Assistance) are the appropriate choices.

Default Extension Treatment Types

Table 2-6 shows the values for the ten default extension treatment types preconfigured in Receptionist II.

Table 2-7 Default Extension Treatment Types

Index	Name	Time Auth Code	Default	RNA	Busy	Reject	Screen
1	Treatment 1	A	D	R	R	R	Y
2	Treatment 2	A	D	R	R	R	N
3	Treatment 3	A	A	R	R	R	Y
4	Treatment 4	A	M	R	R	R	Y
5	Treatment 5	A	M	M	M	R	N
6	Treatment 6	A	M	M	M	M	Y
7	Treatment 7	A	R	M	R	M	Y
8	Treatment 8	v	R	R	R	M	Y
9	Treatment 9	A	R	R	R	R	N
10	Treatment 10	A	M	A	A	A	Y

Trunk Treatment Types

Like extension treatment types, trunk treatments types have an index number, a name, authorized period(s), and authorization code. For a discussion of these parameters, see the Extension Treatment Types parameters.

This section describes the parameters that are unique to trunk treatment types.

Connect Criteria

This parameter applies to Trunk Treatment Types only. The connect criteria are the conditions under which a trunk call is considered to have connected successfully with the called party.

The default value is C, for cut-through, which means that all trunk calls that are outdialed are considered to be successful. You must use this when the PBX cannot provide supervision of outside lines.)

Other choices are T, where the call is successful if it is answered by a computer tone or a dial tone; and R, where a ring-back tone indicates that the trunk call has gone through.

Failure Treatment

This Trunk Treatment Types parameter tells Receptionist II what to do with a trunk call if the connect criteria are not met. The choices for failure treatment are the same as those for the RNA parameter for Extension Treatment Types.

- A Caller is transferred to the Attendant's extension number that is stored in the mailbox data file. If no Attendant's extension number has been specified, caller is transferred to the Console Attendant.
- M Caller is prompted to leave a message in the called party's mailbox.
- R The redial menu that is selected under "Redial Menu to Use" (see below) is played, and Receptionist II follows the caller's instructions.

Note: If the Attendant's extension number does not terminate in an "H" (for hang up), and the call to the Attendant's number does not complete, then Receptionist II looks at the Attendant's extension failure condition and follows the failure treatment that is specified for the extension originally called.

Modifying or Creating Mailboxes

After completing the setup for Receptionist, the system administrator must modify existing mailboxes or create new ones so that system users can use Receptionist II.

Mailbox-Receptionist II Interaction

The administrator must enter the following data for a mailbox so that it can interact with Receptionist II:

- Receptionist day treatment
- Receptionist night treatment
- The extension number that Receptionist should dial when the mailbox is called (the trunk number is entered here when applicable).

Note: Some mailboxes have no associated extensions. For example, the mailbox that plays the "specials of the day" for a business is a "greetings-only mailbox" for which you do not want to assign an extension.

- An extension pre-dial index, when the extension number (or trunk number) to be dialed exceeds 15 characters

- An attendant's extension number (and pre-dial index, if necessary); this number is called when "assistance" is chosen for any failure treatment.

Special Mailboxes for Single-Digit Access

You can configure a single-digit access menu for Receptionist II. This menu allows a caller to press a single digit to get to specified mailboxes. For example, the single-digit menu might provide the following choices:

- To dial an extension, press 1.
- For this week's training schedule, press 2.
- For a customer service representative, press 3.

For this menu, you configure the Administrator's mailbox as a tree mailbox that allows the user to press a single digit to access other mailboxes. In the example given, pressing 1 accesses a chain mailbox to dial an extension or dial by name. Pressing 2 accesses a greetings only mailbox that plays the week's training schedule. Pressing 3 accesses a number answered by a customer service representative.

For instructions on modifying and creating mailboxes, refer to the *VoiceMemo Reference and Configuration Manual*.

Receptionist II Extensions

In an integrated Series 6 Server and PBX system, you can configure Receptionist II to answer a call to the main company number. In addition to the main number, you can configure other Receptionist II extensions to form a hunt group, such that if the main number is busy, the next call goes to another Receptionist II extension.

Note: You configure Receptionist II extensions through the System Maintenance main menu option **Automated Receptionist Extensions**.

Receptionist II Worksheets

This section provides information on how to use Receptionist II worksheets. The worksheets are in the Worksheets section at the back of this manual.

Worksheet 1

If Receptionist II is integrated with a PBX system, you may not have to assign a separate line group for Receptionist II. Refer to the integration manual to determine whether the integration directs you to assign a line group to Receptionist II.

- If you assign a separate line group for Receptionist II, complete both Offline Parameters and Online Parameters sections of Receptionist II Worksheet 1.
- If the integration manual for the PBX switch at your installation site instructs you to configure Receptionist through the integration application menu, complete only the Online Parameters sections of Receptionist II Worksheet 1.

The online parameters on Worksheet 1 are those that Receptionist II shares with the VoiceMemo application. See the *VoiceMemo Reference and Configuration Manual* for a detailed discussion of the parameters on this page.

Worksheet 2

Worksheet 2 contains parameters that are specific to Receptionist II software. Complete the **Default options** section only if the PBX switch at your site is not listed in the preceding section, **PBX Dial String options**.

Worksheets 3 and 4

Worksheet 3 is the Extension Treatment Type worksheet into which you enter frequently-used instructions for specific mailboxes. You might have one set of instructions for managers' mailboxes, another for customer support staff, and another for sales representatives. Putting these instructions in a Treatment Type allows you then to provide a customize mailboxes by using the Treatment Type, rather than by individually configuring each mailbox.

Task List

Page 1 of 1

VoiceMemo Release 6.0A and later

Task *Procedure*

Installation

Install Optional Feature Software CP 5402

Configuration

Receptionist II Configuration CP 6535

VoiceMemo Application Configuration CP 3301

Add Receptionist II Extension Numbers CP 6536

Configure a Tree Mailbox CP 3311

Create a Single-Digit Access Menu CP 6537

Test Setup

Set Up Receptionist II Test Configuration CP 6539

Tests

Test Intermediate Attendant Call Processing CP 6542

Test Mailbox Treatment Types CP 6541

Test Receptionist II Setup CP 6540

VoiceMemo Configuration

VoiceMemo Release 6.0A and later

This procedure summarizes the steps necessary to configure the messaging functions of Receptionist II.

Note: CP references in this procedure are all in the *VoiceMemo Reference and Configuration Manual*.

<i>Step</i>	<i>Reference</i>
<p>1. Go to the VoiceMemo Configuration Online Menu in the active or inactive configuration. <u>Select inactive if you just made a change through the Offline Menu, or active if you did not.</u></p> <p><i>Select:</i> <u>(E) Modify Active Configuration</u> or <u>(F) Modify Inactive Configuration</u> (N) Online Menu</p>	Menu Map 2
<p>2. Schedule company greetings. Use the Day/Night Menu to:</p> <ul style="list-style-type: none"> • Designate the start of the work day • Designate the end of the work day • Designate the weekend 	CP 5024, Ch. 6
<p>3. Establish a dialing plan. If no star prefix is desired, use the Dialing Plan Menu. If a star prefix is desired, use the Star Prefix Dplan Menu to:</p> <ul style="list-style-type: none"> • Specify the trigger digit if Dial-by-Name is desired or • Specify the signal digit if off-system messaging is desired 	CP 5002, Ch. 2
<p>4. If desired, enable <u>Call Placement</u> off-system messaging.</p>	CP 3306, Ch. 4
<p>5. If desired, configure for transfer to a system attendant.</p>	CP 5020, Ch. 2
<p>6. If any of the following are desired, define an administrator's mailbox:</p> <ul style="list-style-type: none"> • Master distribution lists • Company greetings and alternate greeting • Phone administration 	CP 3303, Ch. 6
<p>7. If any of the following are desired, define an attendant's mailbox:</p> <ul style="list-style-type: none"> • Collecting or preventing unaddressed messages • Message of the day • Site tutorial 	CP 3304, Ch. 6
<p>8. If desired, prevent unaddressed messages.</p>	CP 5023, Ch. 2
<p>9. If desired, er</p>	CP 5022, Ch. 2

<i>Step</i>	<i>Reference</i>
10. Set a default language for prompts, if other than English.	CP 3312, Ch. 6
11. If desired, enable Dial-by-Name. <ul style="list-style-type: none">• Code the dialing plan with an A in the digit position that triggers a prompt about spelling the name.• Set the Dial-by-Name parameters.• Include feature bit 92 (user will be in Dial-by-Name database) in the FCOS assigned to mailboxes.	CP 3309, Ch. 2
12. Configure the mailbox passcode parameters.	CP 5021, Ch. 10
13. Verify that the configuration is correct.	CP 5015, Ch. 1
14. If you chose the inactive configuration at the beginning of this procedure, activate the configuration to make the parameter settings take effect.	CP 7002, Ch. 1

Configure a Tree Mailbox

VoiceMemo Release 6.0A and later

This procedure describes how to configure a simple tree mailbox and a nested tree mailbox.

<i>Step</i>	<i>Reference</i>
<ol style="list-style-type: none"> 1. Complete a Mailbox Worksheet and a Tree Mailbox Diagram. Blank worksheets are at the back of this manual. 2. Reach the Mailbox Maintenance Menu. Enter the requested information, as described in the following steps, from your completed Mailbox Worksheets. 	Menu Map 3
<p>☺☺☺ Using the Scrolling Interface</p> <ol style="list-style-type: none"> 3. Identify the tree mailbox. <p><i>Select:</i> (C) Create New Mailboxes <i>Prompt:</i> Mailbox to create: <i>Response:</i> Number of the new mailbox.</p> <p>or</p> <p><i>Select:</i> (M) Modify Mailboxes <i>Prompt:</i> Mailbox to modify: <i>Response:</i> Number of the existing mailbox.</p> <p>Note: Prompts are almost the same for creating a new mailbox and modifying an existing one, except that "New" precedes each prompt when you select Modify Mailboxes.</p> <p>To leave an existing parameter setting unchanged, just press Enter to go to the next prompt.</p> 4. Set the remaining mailbox parameters the same as for a standard mailbox, except for the FCOS and GCOS. 5. Assign an FCOS designed for a tree mailbox. <p><i>Prompt:</i> Features class of service: <i>Response:</i> 15 (the default Tree FCOS),</p> <p>or</p> <p>The number of a customized FCOS that contains all the features of a typical tree mailbox.</p> <p>If you want callers who do not enter a digit promptly after the tree mailbox greeting to be routed to the <i>first</i> subordinate mailbox, include feature bit 120 (default to first child of tree mailbox) in the mailbox FCOS.</p> <p>If you want these callers to be routed to the <i>last</i> subordinate mailbox, include feature bit</p> 	

<i>Step</i>	<i>Reference</i>
<p>6. Assign the same GCOS to the tree mailbox that is assigned to its subordinate mailboxes.</p>	
<p><i>Prompt:</i> Group class of service:</p>	
<p><i>Response:</i> The number of the GCOS (1-64) that contains groups shared by the tree mailbox and all its subordinate mailboxes.</p>	
<p>7. After responding to the last mailbox parameter, the system displays the mailbox configuration, then prompts for the next mailbox number. At this point, the parameter settings for the tree mailbox are saved.</p>	
<p>8. Configure the first subordinate mailbox (the mailbox that callers should be routed to through the tree mailbox).</p>	
<p><i>Prompt:</i> Mailbox to create: or Mailbox to modify:</p>	
<p><i>Response:</i> The number of the first subordinate mailbox.</p>	
<p>9. Set all applicable parameters for the subordinate mailbox the same as for a standard mailbox, except for the GCOS.</p>	
<p>10. Assign the same GCOS to the subordinate mailbox that you assigned to the tree mailbox.</p>	
<p><i>Prompt:</i> Group class of service:</p>	
<p><i>Response:</i> The number of the GCOS (1-64) that contains groups shared by the tree mailbox and all its subordinate mailboxes.</p>	
<p>11. Configure all subordinate mailboxes as just described.</p>	
<p>12. Disable the tutorials in the child mailboxes. Change only the tutorial setting to no, press Enter to skip the other fields.</p>	
	<p><i>VoiceMemo Reference and Configuration Manual</i></p>
<p>13. Create distribution list 1 for the tree mailbox just configured, adding as members all the subordinate mailboxes.</p>	
	<p><i>VoiceMemo Reference and Configuration Manual</i></p>
<p>14. Record an appropriate greeting in the tree mailbox and all child mailboxes.</p>	

*Step**Reference*

☺ Using the Full-Screen Interface

3. Identify the tree mailbox.

Select: (C) Create/Modify/Delete Mailboxes

Response: You are placed in the Mailbox Maintenance entry screen. Enter the **number** of the new or existing mailbox.

Prompt: Mailbox: 00000000nnn

Response: Press **F10** to edit the mailbox information.

4. Set the remaining mailbox parameters the same as for a standard mailbox, except for the FCOS and GCOS. Use the arrow keys, **Tab** key, or **Enter** key to move around the screen, stopping at parameters you wish to change.

*VoiceMemo
Reference and
Configuration
Manual*

5. Assign an FCOS designed for a tree mailbox.

Prompt: Features:

Response: **15** (the default Tree FCOS), *or*

The **number** of a customized FCOS that contains all the features of a typical tree mailbox.

If you want callers who do not enter a digit promptly after the tree mailbox greeting to be routed to the *first* subordinate mailbox, include feature bit 120 (default to first child of tree mailbox) in the mailbox FCOS.

If you want these callers to be routed to the *last* subordinate mailbox, include feature bit 186 (default to last child of tree mailbox) in the mailbox FCOS.

6. Assign the same GCOS to the tree mailbox that is assigned to its subordinate mailboxes.

Prompt: Group:

Response: The **number** of the GCOS (1-64) that contains groups shared by the tree mailbox and all its subordinate mailboxes. Or, use an affinity GCOS (65-32,000), where the tree mailbox and all subordinates have the same GCOS number.

7. Press **F10** to save your changes, or, if you made a mistake, press **F9** to cancel your changes.

<i>Step</i>	<i>Reference</i>
<p>8. Configure the first subordinate mailbox (the mailbox that callers should be routed to through the tree mailbox). Follow the same steps as in configuring the tree mailbox except as listed below.</p> <p><i>Prompt:</i> Mailbox: <i>Response:</i> The number of the first subordinate mailbox.</p> <p><i>Prompt:</i> Mailbox: 00000000nnn <i>Response:</i> Press F10 to edit the mailbox information.</p> <p>9. Set all applicable parameters for the subordinate mailbox the same as for a standard mailbox, except for the GCOS.</p> <p>10. Assign the same GCOS to the subordinate mailbox that you assigned to the tree mailbox.</p> <p><i>Prompt:</i> Group: <i>Response:</i> The number of the GCOS (1-64) that contains groups shared by the tree mailbox and all its subordinate mailboxes. Or, use an affinity GCOS (65-32,000), where the tree mailbox and all subordinates have the same GCOS number.</p> <p>11. Disable the tutorials in each subordinate mailbox.</p> <p><i>Prompt:</i> Tutorial: <i>Response:</i> N to disable the tutorial.</p> <p>12. Save changes to the subordinate mailbox by pressing F10.</p> <p>13. Configure all subordinate mailboxes as just described.</p> <p>14. Exit Mailbox Maintenance (when done with all mailboxes) by pressing F9.</p> <p>15. Create distribution list 1 for the tree mailbox just configured, adding as members all the subordinate mailboxes.</p> <p>16. Record an appropriate greeting in the tree mailbox and all child mailboxes.</p>	<p><i>VoiceMemo Reference and Configuration Manual</i></p>

Step

Reference

Nested Tree Mailbox

1. Choose the subordinate mailbox that you want to be a tree mailbox.
2. Configure the mailbox through the Mailbox Maintenance Menu as described earlier in this procedure.
3. Create distribution list 1 for the nested tree mailbox just configured, adding as members all the subordinate mailboxes related to the nested tree mailbox.
4. Record a greeting in the nested tree mailbox.

*VoiceMemo
Reference and
Configuration
Manual*

Install Optional Feature With System Online

VoiceMemo Release 6.0A and later

The procedure describes how to install an optional feature with the system online. Be sure the Optional Feature Diskette(s) and the Module Enable Diskette contain the serial number(s) for all disk(s) in the system.

Note: The serial number on the OneView Optional Feature diskette must match the serial number of the hard disk on which OneView is being installed. If you receive an error message about an incorrect serial number, contact your support organization.

**CAUTION!**

If you are loading a revision support disk (RSD), do it after completion of this procedure. Loading the RSD first, could create an incorrect configuration.

Note: If you ordered Receptionist II with your Series 6 server, this optional feature is already on your disk. Skip this installation procedure and configure Receptionist II. To determine whether Receptionist II is installed, reach the Configuration option from the Reconfiguration menu. The report lists the applications on your system.

<i>Step</i>	<i>Reference</i>
<p>1. Reach the System Maintenance Menu, then go to the System Maintenance Additional Options Menu.</p>	Menu Map 12
<p>2. Select the Add Optional Feature(s) program.</p> <p><i>Select:</i> (A) Add Optional Feature(s)</p> <p><i>Prompt:</i> Enter 'Y' to add optional features, 'N' to stop:</p> <p><i>Response:</i> Y for Yes.</p>	
<p>3. Install the optional feature.</p> <p><i>Prompt:</i> Insert Optional Feature floppy disk in the floppy drive.</p> <p>Enter any key when ready:</p> <p><i>Response:</i> Insert the Optional Feature diskette, then press Enter.</p>	
<p>4. After you have installed the Optional Feature software, the system asks if you want to install another optional feature.</p> <p><i>Prompt:</i> Do you want to install another optional feature?</p> <p><i>Response:</i> Y to install another optional feature and continue from step 3, N if you are done installing optional features.</p>	
<p>The system automatically edits and saves the configuration files, then returns to the Additional Options Menu.</p>	

<i>Step</i>	<i>Reference</i>
5. Exit the VoiceMemo Configuration Offline Menu. You see the following prompt: <i>Prompt:</i> Wait for message waiting queues to be empty? <i>Response:</i> N to continue.	
6. The following prompt appears: <i>Prompt:</i> Wait for paging queues to be empty? <i>Response:</i> N to continue.	
7. Exit to the VoiceMemo Configuration - Main Menu, then go to the VoiceMemo Configuration - Offline Menu.	Menu Map 2
8. Duplicate the active configuration. <i>Select:</i> (B) Duplicate Active Configuration	
9. Exit to the VoiceMemo Configuration - Main Menu and activate the configuration. <i>Select:</i> (A) Activate Configuration	

Receptionist II Configuration

VoiceMemo Release 6.0A and later

This procedure sets the values for parameters that Receptionist II uses to process calls and to interact with mailboxes. Set the parameters by entering the values that you wrote on Receptionist II Worksheets 2 through 4 (see Chapter 2).

Step

Reference

☎ Display the Receptionist Menu

1. Reach the VoiceMemo Configuration Main Menu, then go to the VoiceMemo Configuration Online Menu in the active or inactive configuration. Select inactive if you just made a change through the Offline Menu, and have not yet activated the configuration, or active if you have already activated the configuration.

Select: (E) Modify Active Configuration

or

(F) Modify Inactive Configuration

Prompt: Online menu:

Response: Specify the line group for Receptionist II.

Select: (G) Group Selected

Prompt: Enter a group number =

Response: The **number** of the line group (1-24)

or

Press **Enter** if the current number is correct.

Menu Map 2

☎ Set PBX Dialing Plan Options

1. Reach the Receptionist Menu, then go to the Dialing Plan Options Menu.
2. Change the dialing plan, if desired.

Select: (P) Dialing Plan

Prompt: Dialing Plan = [3,3,3,3,3,3,3,0,0]

Response: Change values to match those on Worksheet 2, as needed.

3. If the PBX on the site requires that digits be deleted for some numbers in the dialing plan, configure the Delete Digits table. Consulting your worksheet, enter the number of leading digits to be deleted in accordance with the dialing plan.

Select: (D) Delete Digits

Prompt: Delete Digits = [0,0,0,0,0,0,0,0,0]

Response: Change values to match those on Worksheet 2, as needed.

Menu Map 13

<i>Step</i>	<i>Reference</i>
4. If the site's PBX require offsets in the dialing plan, define the tables that require offsets.	
<i>Select:</i> (F) Offset Table	
<i>Prompt:</i> DIALING PLAN:	
<i>Response:</i> (D) Define Table	
<i>Prompt:</i> Define table number (1 to 9) [1]	
<i>Response:</i> The first digit (before any deletions) of the extensions to which the offset will be added.	
<i>Prompt:</i> Table offset = [0]	
<i>Response:</i> The offset value for this table.	
5. Repeat step 4 as necessary. The Offset Table Menu is redisplayed after you enter the offset value of a table.	
6. Change the Timeout for Receipt of first DTMF Digit value, if desired.	
<i>Select:</i> (T) Timeout for Receipt of First Digit	
<i>Prompt:</i> Timeout for Receipt of First DTMF digit (.1 seconds) = [0]	
<i>Response:</i> The new timeout value from your worksheet.	
7. Change the PBX Console Day Access Code, if desired.	
<i>Select:</i> (Y) PBX Console Attendant Day Access Code	
<i>Prompt:</i> PBX Console Attendant Day Access Code = [0H]	
<i>Response:</i> The new access code value from your worksheet.	
8. Change the PBX Console Night Access Code, if desired.	
<i>Select:</i> (Z) PBX Console Attendant Night Access Code	
<i>Prompt:</i> PBX Console Attendant Night Access Code = [0H]	
<i>Response:</i> The new access code value from your worksheet.	
9. Exit to the Receptionist Menu.	

Step

Reference

☺ Set Flow Options

1. From the Receptionist Menu, go to the Flow Options Menu.
2. Change the default values, if desired.

Menu Map 13

Select: (M) Mailbox Message Prompt Greeting/Name (G/N)

Prompt: Mailbox Message Prompt Greeting/Name (G/N)
[G]

Response: Change the default prompt value, if desired.

Select: (P) PBX Console Operation

Prompt: (P) PBX Console Operation (N/Y) [N]

Response: Y, if desired.

Y replaces the initial welcome greeting with a short dial tone to prompt the operator that the Receptionist II is ready to receive the extension number.

3. Exit to the Receptionist Menu.

☺ Set PBX Dial String Definitions

1. Initialize the values for the dial string definitions for the PBX on your site.

Select: (P) PBX Dial String Definitions

Prompt: PBX:

Response: The **letter** that corresponds to the PBX at the installation site

or

Press **Z** for default PBX options

Prompt: Initialize to Default Values (y/n)

Response: Y to keep the default values,
N if you wish to change one or more values.

<i>Step</i>	<i>Reference</i>
<p>2. If desired, change the values for any of the following parameters to the new values on your worksheet.</p> <p><i>Select:</i> (A) Post Directory number dial string (B) Pre Directory number dial string / Attendant xfer string (C) Connect Dial string on Called Party Accept (E) Dial string for Return on Called Party Refused (F) Dial string for Return on Called Party Busy (G) Special actions on Reorder Tone Encountered (H) Dial string for Return on Called Party RNA</p> <p><i>Prompt:</i> [Default]</p> <p><i>Response:</i> New value from your worksheet.</p> <p>3. Exit to the Receptionist Menu.</p>	
<p>☺☺ Set Extension Treatment Types</p>	
<p>1. At the Receptionist Menu, go to the Trunk/Extension Treatment Types Menu.</p> <p><i>Select:</i> (C) Current Index Number <i>Prompt:</i> Current Index Number = [N] <i>Response:</i> The index number of an extension treatment type on Worksheet 3.</p> <p><i>Select:</i> (N) Name of Current Index <i>Prompt:</i> Name of Current Index = [] <i>Response:</i> The name that corresponds to the index number you entered in the previous step.</p> <p>2. Limit mailbox access to either days or nights/weekends, if desired.</p> <p><i>Select:</i> (P) Authorized Periods <i>Prompt:</i> Authorized Periods (A/N/D) <i>Response:</i> A for any, D for day only, N for night and weekend only.</p> <p>3. If desired, require users to have an authorization code to use mailboxes with the current treatment type.</p> <p><i>Select:</i> (A) Authorized Code <i>Prompt:</i> Authorized Code (0-9/*/#/A-D/M/P) = [] <i>Response:</i> The code shown on your worksheet.</p> <p>4. Reach the Extension Type Setup Menu..</p>	<p>Menu Map 13</p> <p>Menu Map 13</p>

<i>Step</i>	<i>Reference</i>
<p>5. Change any values that do not correspond to those in Worksheet 4.</p> <p><i>Select:</i> (E) Extension Type Setup <i>Prompt:</i> EXTENSION SETUP: <i>Response:</i> The values for any or all of the options that follow, as applicable.</p> <p><i>Select:</i> (S) Screen Calls? <i>Prompt:</i> Screen Calls? (Y/N <i>Response:</i> Y to announce the caller's name to the called party to accept or reject, N to connect the call after greeting the called party.</p> <p><i>Select:</i> (R) RNA Treatment? (R/A/M) <i>Prompt:</i> RNA Treatments? (R/A/M) = [R] <i>Response:</i> R to go into the Redial Menu, A to call the attendant, M to drop into VoiceMemo to take a message.</p> <p><i>Select:</i> (B) Busy Treatment? <i>Prompt:</i> Busy Treatment? (R/A/M) = [R] <i>Response:</i> R to go into the Redial Menu, A to call the attendant, M to drop into VoiceMemo to take a message.</p> <p><i>Select:</i> (J) Reject Treatment? (R/A/M) <i>Prompt:</i> Reject Treatment? (R/A/M) = [R] <i>Response:</i> R to go into the Redial Menu, A to call the attendant, M to drop into VoiceMemo to take a message.</p>	
<p>6. Exit to the Trunk/Extension Treatment Types Menu to save the values.</p>	
<p>7. If desired, specify where the caller is to be routed after a Busy or Ring-No-Answer condition, when the caller does not enter any new instruction.</p>	
<p><i>Select:</i> (D) Redial Menu to Use <i>Prompt:</i> Redial Menu to Use (M/A/D/R) [D] <i>Response:</i> M to call extension's mailbox in 3 seconds, A to call the PBX attendant in 6 seconds, D to disconnect from receptionist after 6 seconds, R means to redial the call.</p>	
<p>8. Exit to the Receptionist Menu to save your changes.</p>	
<p>9. Repeat steps 1 to 8 of this section until you have configured all the extension treatment types you need.</p>	
<p>10. Exit to the Configuration Main Menu.</p>	

Step

Reference

11. **Activate** the configuration if you have been working in the Offline inactive configuration or the Online inactive configuration.

or

Exit to the Main Menu.

☺☺ Set Trunk Treatment Types

1. Reach the Trunk/Extension Treatment Types Menu.

Select: (C) Current Index Number

Prompt: Current Index Number = [#]

Response: The **index number** of a trunk treatment type from Worksheet 4.

Select: (N) Name of Current Index

Prompt: Name of Current Index = [treatment 1]

Response: The **name** that corresponds to the index number you entered in the previous step.

2. Limit mailbox access to either days or nights/weekends, if desired.

Select: (P) Authorized Periods

Prompt: Authorized Periods (A/N/D)

Response: **A** for any,
D for day only,
N for night and weekend only.

3. If desired, require users to have an authorization code to use mailboxes with the current treatment type.

Select: (A) Authorized Code

Prompt: Authorized Code (0-9/*/#/A-D/M/P) = []

Response: The **code** shown on your worksheet.

4. Change connect criteria or failure treatment values, if desired.

Menu Map 13

<i>Step</i>	<i>Reference</i>
<p><i>Select:</i> (T) Trunk Type Setup <i>Prompt:</i> Current index number [1] is set to EXTENSION type. Do you want to change to TRUNK type ? (Y/N) <i>Response:</i> Y to change the index number to trunk type.</p> <p><i>Select:</i> (C) Connect Criteria? (C/T/R) = [C] <i>Prompt:</i> (C) Connect Criteria? (C/T/R) = [C] <i>Response:</i> C to tell VoiceMemo to assume that the connection is successful, T to expect a dial or modem tone., R to expect a ring back tone.</p> <p><i>Select:</i> (F) Failure Treatment? (R/A/M) = [R] <i>Prompt:</i> (F) Failure Treatment? (R/A/M) = [R] <i>Response:</i> R to go into the Redial Menu, A to call the attendant, M to drop into VoiceMemo to take a message.</p>	
5. Exit to the Trunk/Extension Treatment Types Menu to save the values.	
6. If desired, specify where the caller is to be routed after a Busy or Ring No Answer condition, when the caller does not enter any new instruction.	
<p><i>Select:</i> (D) Redial Menu to Use <i>Prompt:</i> Redial Menu to Use (M/A/D/R) [D] <i>Response:</i> M to call extension's mailbox in 3 seconds, A to call the PBX attendant in 6 seconds, D to disconnect from Receptionist after 6 seconds, R to redial the call.</p>	
7. Save values and return to the Receptionist Menu.	
8. Repeat steps 1 to 7 of this section until you have configured all the trunk treatment types you need.	
9. Exit to the Configuration Main Menu.	
10. Activate the configuration if you have been working in the Offline inactive configuration or the Online inactive configuration.	
or	
Exit to the Main Menu.	
11. Configure Receptionist II extensions, if desired.	CP 6537

Add Receptionist II Extension Numbers

VoiceMemo Release 6.0A and later

This optional procedure adds Receptionist II extension numbers. Use this procedure if you have a heavily used system and require a hunt group for Receptionist II.

<i>Step</i>	<i>Reference</i>
<p>☛ Add an Extension</p> <ol style="list-style-type: none"> 1. Reach the System Maintenance Main Menu, then go the Automated Receptionist Extensions Menu. 2. Add a Receptionist II extension number. <ul style="list-style-type: none"> <i>Select:</i> (B) Automated Receptionist Extensions <i>Prompt:</i> COMMAND (A/D/P/R/X) : <i>Select:</i> (A) Add an extension <i>Prompt:</i> Receptionist's extension to add: <i>Response:</i> Receptionist II extension number. 3. Press Enter to save the number. 4. Print the extension list. <ul style="list-style-type: none"> <i>Select:</i> (P) Print the extension list. 	Menu Map 12
<p>☛ Delete an Extension</p> <ol style="list-style-type: none"> 1. Reach the Automated Receptionist Extensions Menu. <ul style="list-style-type: none"> <i>Select:</i> (D) Delete an extension <i>Prompt:</i> Receptionist's extension to delete: <i>Response:</i> Extension number. 2. Press Enter to save the number. 3. Print the extension list. <ul style="list-style-type: none"> <i>Select:</i> (P) Print the extension list. 	
<p>☛ Change the Receptionist Dial String</p> <ol style="list-style-type: none"> 1. Reach the Automated Receptionist Extensions Menu. 2. Display the Receptionist II dial string. <ul style="list-style-type: none"> <i>Select:</i> (P) Print the extension list. 	Menu Map 12

<i>Step</i>	<i>Reference</i>
<p>3. Change the Receptionist dial string, if desired.</p> <p><i>Select:</i> (R) Change Receptionist Dial String <i>Prompt:</i> New Receptionist Dial String? <i>Response:</i> New dial string.</p> <p>A Receptionist Dial String can vary from 1-16 digits (0-9, A-D, +, *, #)</p> <p>The dial string is sent by an integrated VoiceMemo port when a Receptionist port is forwarded to it. This is usually used to tell the Receptionist port to hang up by putting a '#' into the dial string.</p> <p>4. Exit to save your changes.</p>	

Create a Single-Digit Access Menu

VoiceMemo Release 6.0A and later

This procedure configures a single-digit access menu. Use this procedure to give callers quick access to frequently-called departments or persons.

Step

Reference

- Using the following tree structure, create the required mailboxes.

CP 3311

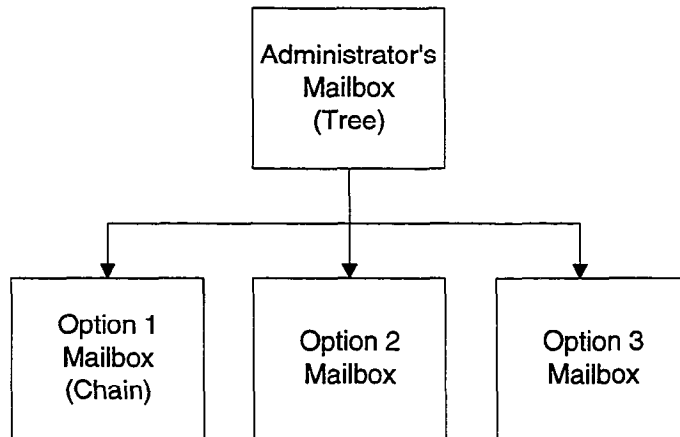

Assign FCOS 15 to the administrator's mailbox. Configure the other mailboxes as subordinate mailboxes in a tree configuration; if one of the options allows the user to dial an extension or dial by name, assign FCOS 8 to the mailbox.

CP 3311

Sample subordinate mailboxes: Option 1 – Dial an extension or dial by name; Option 2 – Technical Support; Option 3 – Job Hotline

Set Up Receptionist II Test Configuration

VoiceMemo Release 6.0A and later

The procedure summarizes the procedures for testing Receptionist II configuration. The test setup uses three 2500 sets, designated as Station A, Station B, and Station C. The test Console Attendant is the actual Attendant (if any) who provides assistance to callers who "wait," in response to the prompt, "Please enter an extension number, or wait for assistance."

Step

Reference

☎ Set Up Telephone Sets

1. Set up three telephone sets, Station A, Station B, and Station C, as shown in Figure 1.
2. Record the **extension numbers** of Stations B and C. You will be associating mailboxes with these telephones.
3. If desired, set up a Console Attendant phone.
4. Connect a PBX line to the Receptionist II port.
5. Record the Reception II **extension number**.

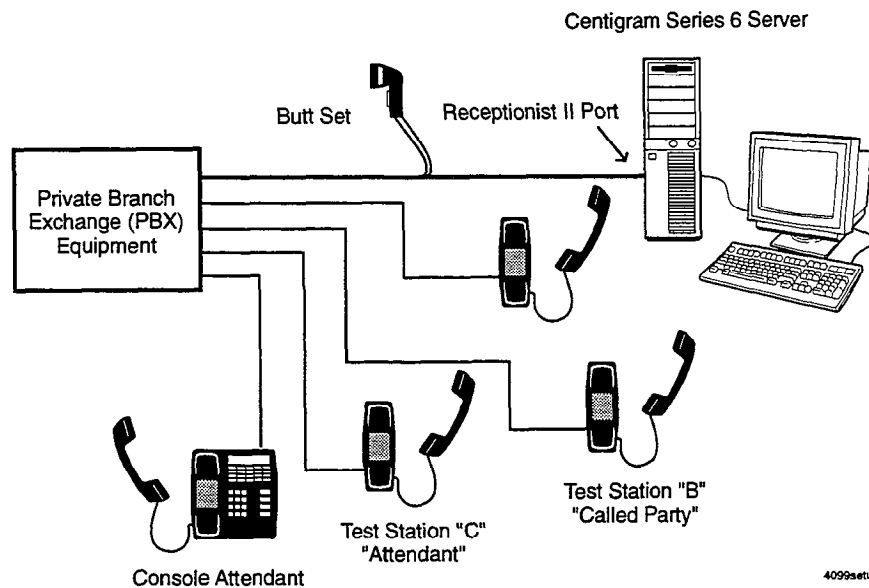

Figure 1 Receptionist II Test Configuration

<i>Step</i>	<i>Reference</i>
<p>☞ Add Phonenumber Exceptions</p> <ol style="list-style-type: none">1. Reach the Phonenumber Exceptions Menu.2. Add phonenumber exceptions. <i>Select:</i> (A) Add exceptions <i>Prompt:</i> Keep entering triplets, then enter <CR> on a line by itself. line triplets to change: <i>Response:</i> Line triplet of an Series 6 server phone port connected to the PBX, or a range of line triplets if your SL-1 ports are contiguous. <i>Prompt:</i> Command= <i>Response:</i> 9 (Ringing Timeout) <i>Prompt:</i> Value= <i>Response:</i> 11 (3 rings) <i>Prompt:</i> Command= <i>Response:</i> 11 (Speak Timeout) <i>Prompt:</i> Value= <i>Response:</i> 1 (for quicker response from Receptionist II) <p>☞ Create Mailboxes for Tests</p> <ol style="list-style-type: none">3. Create a mailbox with the following characteristics:<ul style="list-style-type: none">• Mailbox number = Station B's extension number• Day or Night Treatment type = the treatment type (1-16) that you wish to test• Mailbox's extension number = Station B's extension number• Attendant's extension number = Station C's extension number• Unlimited Feature COS• Tutorial = N	Menu Map 10

<i>Step</i>	<i>Reference</i>
<p>4. Create a mailbox with the following characteristics:</p> <ul style="list-style-type: none">• Mailbox number = Station C's extension number• Mailbox's extension number = Station C's extension number• Unlimited Feature COS• Tutorial = N <p>5. Record a name in Mailboxes B and C.</p> <ol style="list-style-type: none">a. Call in to the Message Center, and log into Mailbox B.b. Press TUV 8 for User Options.c. Press MNO 6, then record the Mailbox name, "Called Party."d. Press WXY 9 to exit User Options.e. Press WXY 9 twice in succession to return to the Message Center greeting.	
<p>☎ Test the Configuration</p>	
<p>6. Test Receptionist II setup: greetings and assistance call processing, dialing plan and mapping of mailboxes to extension, call screening, reorder tone.</p>	CP 6539
<p>7. Test mailbox treatment types.</p>	CP 6940
<p>8. Test intermediate attendant call processing.</p>	CP 6541

Test the Receptionist II Setup

VoiceMemo Release 6.0A and later

The procedures in this section test Receptionist II setup for processing calls:

- Greetings and Assistance Call Processing
- Dialing plan and mapping of mailboxes to extensions
- Call screening
- Reorder tone

*Step**Reference*

☎ Test Greetings and Assistance Call Processing

1. Call into the Receptionist II main number from Station A. Check that the proper greeting, Day or Night, is played for the time period.
2. Allow the call to time out (wait).

If a PBX Console Attendant's Access Code is configured for the time period, listen on the butt set for:

- Pre-DN string dialing, including the switch hook flash
- PBX Console Attendant Day Access Code dialing
- Post-DN string dialing
- Answer

If no PBX Console Attendant's Access Code is configured, but the line group does have an Attendant's Mailbox:

- The wait prompt, if enabled, should say "Please enter an extension number or wait." (Receptionist II should automatically eliminate the prompt for assistance).
- Upon timeout, you should be prompted to "Please leave your name, the name of the person you are calling, and a message."

If neither a Console Attendant nor an Attendant's Mailbox is configured, be sure that the Wait Prompt is disabled

3. Repeat steps 1 and 2 for the other time period, to be sure that greetings and assistance call processing are correct for both day and night/weekend hours.

☎ Test Dialing Plan

Refer to Receptionist II Worksheet 2.

1. For each leading digit that does not have a zero in the dialing plan, call at least one extension with the correct number of digits, and one extension that is incorrect, to be sure that Receptionist II accepts the valid extension number, and rejects the invalid one.
2. When the dialing plan specifies "V," for variable length, test several lengths to be sure that they are accepted.

<i>Step</i>	<i>Reference</i>
<ol style="list-style-type: none"> 3. Enter one extension number for each group of extensions that show a zero in the dialing plan. Receptionist II should reject all such extensions. 4. Repeat steps 1 through 3 for the other time period, to be sure that greetings and assistance call processing are correct for both day and night/weekend hours. 	
<p>☞ Test Mapping</p>	
<p>If delete digits or offsets are set for any group of extensions, enter the number of the “called party” test extension into the extension field of a mailbox that will be reached by this mapping. If the number is mapped correctly, the test extension will ring. Follow this procedure for each group of mailboxes with leading digits that specify mapping.</p>	
<ol style="list-style-type: none"> 5. Repeat steps 1 through 3 for the other time period, to be sure that greetings and assistance call processing are correct for both day and night/weekend hours. 	
<p>☞ Test Call Screening: Call Accepted</p>	
<ol style="list-style-type: none"> 1. Dial Receptionist II from Station A. Be sure that Receptionist II answers with the appropriate greeting. 2. Enter the mailbox number of Station B. 3. When Receptionist II says, “I will ring [called party]. Whom may I say is calling?” say your name. 	
<p>Receptionist II says, “Please hold.”</p>	
<ol style="list-style-type: none"> 4. Leave Station A off hook, and listen on the butt set for: <ul style="list-style-type: none"> • Pre-DN string dialing • Extension number dialing • Post-DN string dialing • Ringing - Count the number of rings! 	
<ol style="list-style-type: none"> 5. Answer the call at Station B. Listen for “Hello, you have a call from [your name]. Press A to accept the call, R to refuse it.” 	
<ol style="list-style-type: none"> 6. Press A. Listen on the buttset while Receptionist II dials the Connect dial string on called party accept (Menu 8), then releases the call. Adjust this string if Station A fails to connect with Station B. 	

Step

Reference

☎ Call Screening: Call Rejected

1. Dial Receptionist II from Station A. Be sure that Receptionist II answers with the appropriate greeting.
2. Enter the mailbox number of Station B.
3. When Receptionist II says, "I will ring Called Party. Whom may I say is calling?" say your name.
Receptionist II says, "Please hold."
4. Leave Station A off hook, and listen on the butt set for:
 - Pre-DN string dialing
 - Extension number dialing
 - Post-DN string dialing
 - Ringing - Count the number of rings!
5. Answer the call at Station B. Listen for "Hello, you have a call from [your name]. Press A to accept the call, R to refuse it."
6. Press R, then hang up the phone at Station B. Listen on the butt set while Receptionist II dials the Dial string for return on called party refused. Adjust this string if Receptionist II fails to return to Station A.
7. Listen at Station A as Receptionist II says "I'm sorry [your name] did not answer."
The system then acts according to the Reject treatment type for Station B (play a redial menu, force to assistance, or force to the mailbox to leave a message).
8. If the treatment type does not perform as expected (for example, the caller was forced to assistance when a redial menu was desired), go back into the reconfiguration program, and change the Reject treatment type programming.

☎ Test Reorder Tone

1. Call into Receptionist II from Station A.
2. Dial an invalid extension number that conforms to the PBX dialing plan (or an extension that is set to "do not disturb," if the PBX gives reorder tone on do not disturb).
3. Listen on the butt set to the reorder tone.
4. Receptionist II should return to Station A, and play the prompt that is appropriate for the "Special actions on reorder tone encountered" dial string.

Test Mailbox Treatment Types

VoiceMemo Release 6.0A and later

This test plan verifies that the extension and trunk treatment types that you have configured process calls correctly in the following situations

- Busy
- Ring No Answer (RNA)
- Call screening

The test plan also tests whether the trunk treatment types that you have configured process calls correctly in the following situations:

- Successful connection
- Failure treatment on Busy

*Step**Reference*

☎ Busy

1. Take Station B (the "Called Party") off-hook.
2. Dial Receptionist II from Station A (the "Calling Party"). Be sure that Receptionist-II answers with the appropriate greeting.
3. Enter the **mailbox number** of Station B.

Receptionist II says, "I will ring Called Party. Whom may I say is calling? (if the treatment type has call screening) Please hold."

4. Listen on the butt set for:
 - Pre-DN string dialing
 - Extension number dialing
 - Post-DN string dialing
 - A busy tone
 - Return string
 - Receptionist II's response to the failure condition

☎ Ring No Answer (RNA)

1. Dial Receptionist II from Station A. Be sure that Receptionist II answers with the appropriate greeting.
2. Enter the **mailbox number** of Station B.

Receptionist II says, "I will ring Called Party. Whom may I say is calling? (if the treatment type has call screening) Please hold."

<i>Step</i>	<i>Reference</i>
<p>3. Listen on the butt set for:</p> <ul style="list-style-type: none">• Pre-DN string dialing• Extension number dialing• Post-DN string dialing• Ringing - Count the number of rings!• Return string• Receptionist II's response to the failure condition. <p>4. If the treatment type does not perform as expected (for example, the caller was forced to assistance when a redial menu was desired), go back into the reconfiguration program and change the treatment type programming.</p>	
<p>☎ Test Failure Test</p>	
<p>This test can only be done for trunk treatment types with connect criteria T (Tone) or R (Ringing).</p>	
<p>1. Busy out Trunk B (the "Called Party").</p>	
<p>2. Note the proper connect criteria for the treatment type:</p>	
<p>C = Cut through (All calls that are dialed are considered successful.)</p>	
<p>T = Tone (A call is successful if Receptionist II encounters a dial tone or computer tone after dialing the number)</p>	
<p>R = Ringing (Receptionist II considers the call successful only if it receives ringing in response to dialing the number)</p>	
<p>Be sure the trunk number that you are dialing can answer with the response that matches the connect criteria.</p>	
<p>3. Dial Receptionist II Trunk A. Check that Receptionist II answers with the appropriate greeting.</p>	
<p>4. Enter the number of Mailbox B.</p>	
<p>5. Receptionist II says, "I will ring Called Party. Please hold."</p>	
<p>6. Listen on the butt set for:</p>	
<ul style="list-style-type: none">• Pre-DN string dialing	
<ul style="list-style-type: none">• Mailbox's extension number dialing	
<ul style="list-style-type: none">• Post-DN string dialing	
<p>7. If the failure treatment does not perform as expected, go back into the reconfiguration program and adjust the treatment type programming.</p>	

Test Intermediate Attendant Call Processing

VoiceMemo Release 6.0A and later

This test determines if Receptionist II processes calls to the Attendant's extension number.

<i>Step</i>	<i>Reference</i>	
<ol style="list-style-type: none"> 1. Take Station B (the "Called Party") off-hook. 2. Dial Receptionist II from Station A (the "Calling Party"). Be sure that Receptionist II answers with the appropriate greeting. 3. Enter the mailbox number of Station B. 4. Receptionist II says, "I will ring Called Party. Whom may I say is calling? (if there is call screening) Please hold." 5. When Receptionist II returns to Station A, choose the assistance option. 6. Listen on the butt set for: <ul style="list-style-type: none"> • Pre-DN string dialing, including the switch hook flash • Attendant's extension number dialing • Post-DN string dialing (Menu 8) • Ringing 7. Answer station C. Receptionist II should announce, "Hello. You have a call for Called Party." <ul style="list-style-type: none"> • If Mailbox B's treatment type specifies call screening, Receptionist II will issue the call screening prompts. Accept the call. 		
<p>☞ Troubleshooting</p> <ol style="list-style-type: none"> 1. Check switch hook flash timing. If the VoiceMemo program does not put Station A on hold before dialing, the switch hook flash timing may be too short; if Station A is disconnected almost immediately, the switch hook flash timing is too long. See the Phonenumber Exceptions section of your <i>Centigram Series 6 Installation and Service Manual</i> for instructions on adjusting Telephony Parameter #23, flash time. 2. If a dial string in step 6 fails, go back into the reconfiguration program and adjust the dial string programming. 3. If the treatment type does not perform as expected, go back into the reconfiguration program and change the treatment type. 		<p>CP 6535</p> <p>CP 6535</p>

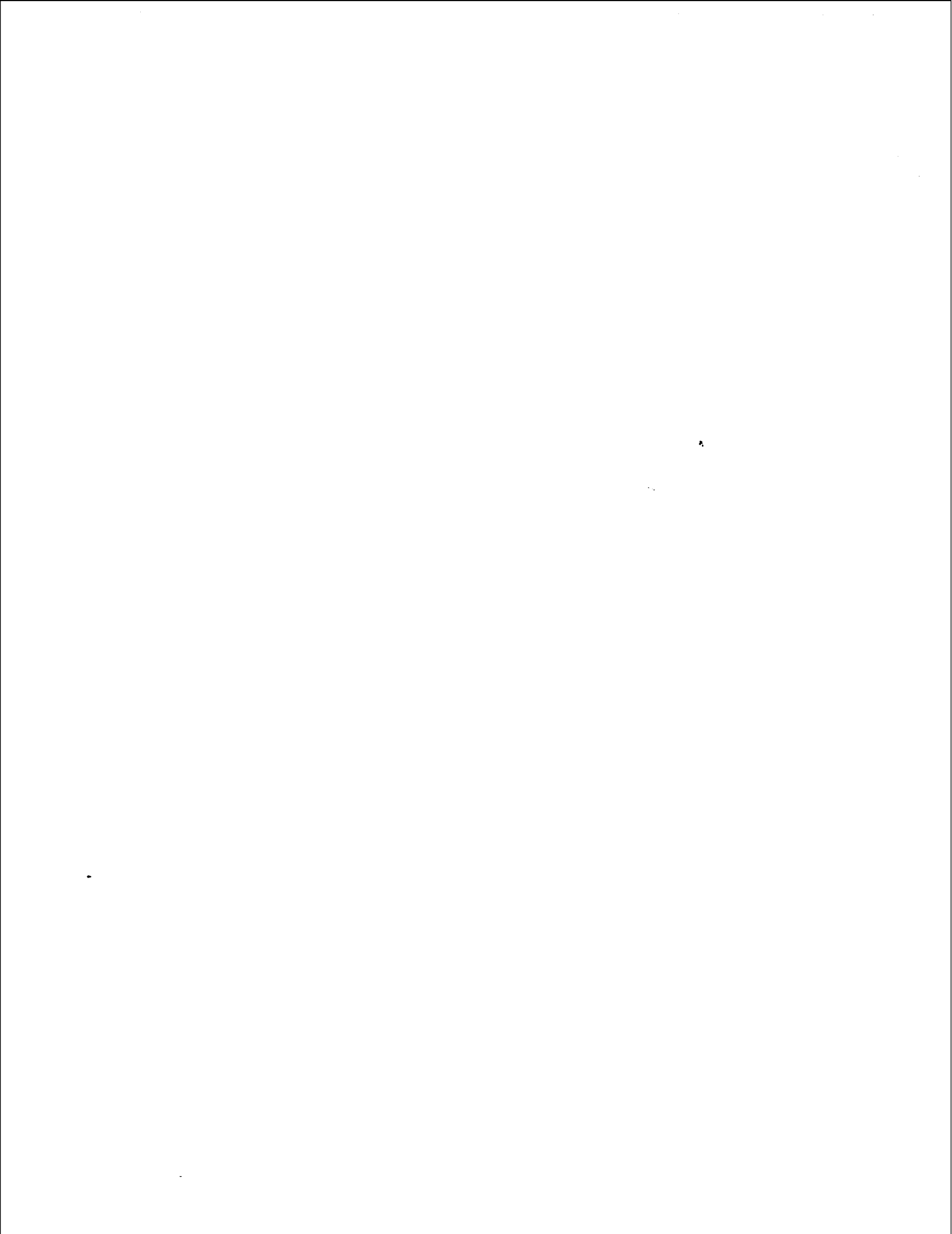

Worksheets

This section contains worksheet for Receptionist II configuration. You may wish to make copies of these worksheets and keep the originals for future reference.

Receptionist II Worksheet 1

Offline Parameters

Define line groups

Current group

Add lines to current group

Name of current group

Drop lines from current group

Line group only applications

Group selected

Assign VoiceMemo yes
 no

Online Parameters

Dialing plan options

Dialing plan
1 2 3 4 5 6 7 8 9

Delete digits table

Console day access code

Offset table

Console night access code

Flow options

Message prompt? yes
 no

Greeting

Name

Console operation mode? yes
 no

PBX Dial String options

ROLM	<input type="radio"/>	Hitachi DX	<input type="radio"/>	75/85	<input type="radio"/>
SL-1	<input type="radio"/>	Mitel Focus	<input type="radio"/>	Telex	<input type="radio"/>
AT&T Dimension	<input type="radio"/>	NEC	<input type="radio"/>	Siemens Saturn	<input type="radio"/>
Centrex	<input type="radio"/>	AT&T System	<input type="radio"/>	Fujitsu	<input type="radio"/>

Default options

Post-DN string

Dial string for return on called party refused

Pre-DN string

Dial string for return on called party busy or RNA

Connect dial string on called party accept

Special actions on reorder tone encountered

Receptionist II Worksheet 2

Online Parameters

Day/Night

Start time of workday

 AM
 PM

Weekend days

<input type="checkbox"/>	<input type="checkbox"/>	<input type="checkbox"/>	<input type="checkbox"/>	<input type="checkbox"/>	<input type="checkbox"/>	<input type="checkbox"/>
M	T	W	Th	F	Sa	Su

End time of workday

 AM
 PM

Dialing Plan Menu

Dialing plan

<input type="checkbox"/>	<input type="checkbox"/>	<input type="checkbox"/>	<input type="checkbox"/>	<input type="checkbox"/>	<input type="checkbox"/>	<input type="checkbox"/>	<input type="checkbox"/>	<input type="checkbox"/>
1	2	3	4	5	6	7	8	9

Optional star*
prefix dialing
plan

<input type="checkbox"/>	<input type="checkbox"/>	<input type="checkbox"/>	<input type="checkbox"/>	<input type="checkbox"/>	<input type="checkbox"/>	<input type="checkbox"/>	<input type="checkbox"/>	<input type="checkbox"/>
1	2	3	4	5	6	7	8	9

Dial string and mailbox menu

System attendant's extension

Attendant's transfer string or PBX predirectory #

Administrator's mailbox #

Attendant's mailbox #

E-mail transfer string

General greeting mailbox #

Pre-company name dial string

Pre-mailbox greeting dial string

Dial-by-Name menu

Last name first flag?

 yes
 no

Single digit access?

 yes
 no

Number of names threshold

Exact match break?

 yes
 no

Suppress mailbox number?

 yes
 no

Allow Dial an Extension menu

Allow dial and extension for callers?

 yes
 no

Allow dial and extension for users?

 yes
 no

Receptionist II Worksheet 3

Extension Treatment Types

Index number

Index name

Authorized period

all

day only

night only

Authorization code

Extension type setup

Screen calls?

yes

no

RNA treatment

Redial menu

Assistance only

Mailbox only

Busy treatment

Redial menu

Assistance only

Mailbox only

Reject treatment

Redial menu

Assistance only

Mailbox only

Extension Treatment Types

Index number

Index name

Authorized period

all

day only

night only

Authorization code

Extension type setup

Screen calls?

yes

no

RNA treatment

Busy treatment

Redial menu

Assistance only

Mailbox only

Reject treatment

Redial menu

Assistance only

Mailbox only

Receptionist II Worksheet 4

Trunk Treatment Types

Index number

Index name

Authorized period

all

day only

night only

Authorization code

Trunk Type Setup

Failure treatment

Cut through

Tone

Ring

Redial menu to use

Redial menu

Assistance only

Mailbox only

Reject treatment

Redial

Assistance

Disconnect

Trunk Treatment Types

Index number

Index name

Authorized period

all

day only

night only

Authorization code

Trunk Type Setup

Failure treatment

Cut through

Tone

Ring

Redial menu to use

Redial menu

Assistance only

Mailbox only

Reject treatment

Redial

Assistance

Disconnect

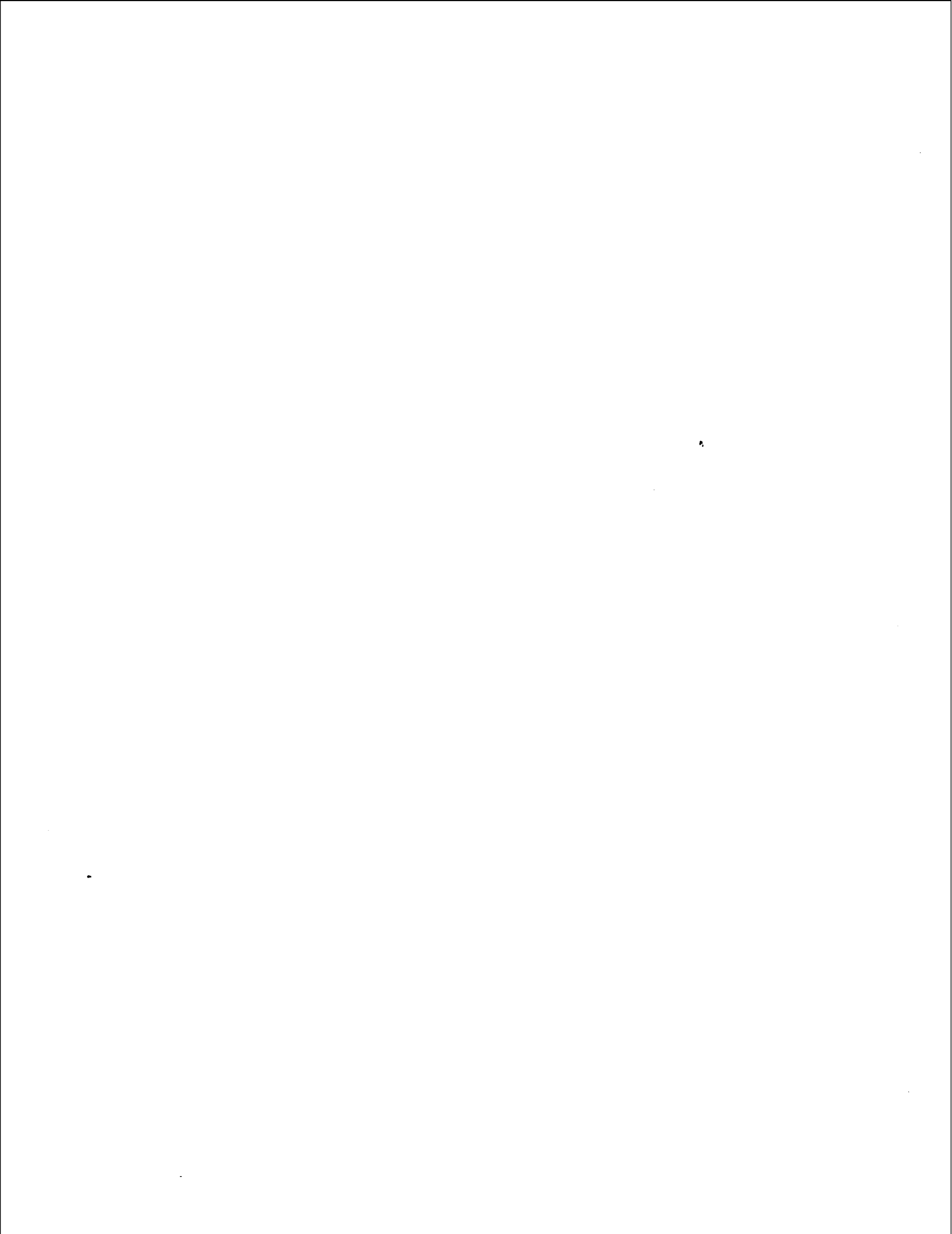

Index

#

dial around, 1-3

C

call screening, 1-2

conversion

 extension to associated mailbox number, 1-7

 extension-to-mailbox Number, 1-8

D

day/night, 1-2

day/night access code, 2-6

 PBX, 2-6

 sequence, 2-7

Delete Digits Table, 2-3

Dial String

 ATT, 2-12

 busy, 2-10

 Centrex, 2-12

 connect, 2-10

 Fujitsu, 2-12

 Hitachi, 2-12

 Mitel, 2-12

 NEC, 2-12

 NT SL-1, 2-12

 PBX, default values, 2-12

 PBX, definitions, 2-8

 PBX, post-directory number, 2-9

 PBX, pre-directory number, 2-9

 preprogrammed, 2-12

 reconnect caller, 2-10

 RNA, 2-10

 ROLM, 2-12

 Siemens, 2-12

 Telex, 2-12

E

Extension Treatment Type, 2-13

 authorization code, 2-14

 authorized period, 2-14

 Busy, 2-15

 index name, 2-13

 index number, 2-13

 redial menu, 2-15

 Reject, 2-15

 RNA, 2-15

 screen calls, 2-14

Extension Treatment Types

 defaults table, 2-17

F

Flow Options, 2-7

 mailbox message prompt, 2-7

 PBX console operation, 2-8

I

installation

 optional feature, CP 5402

L

log into mailbox

 mailbox number followed by #, 1-4

logging into mailbox, 1-3

M

menu

 Redial Menu to Use, 2-16

 single-digit access, 1-3, 1-9

 to direct outside callers to extension or mailbox, 1-3

O

Offset Table, 2-4

optional features, installing, CP 5402

P

PBX dial plan

Index

defined, 2-2

PBX dialing plan, 2-2

Prompts, 1-2

R

Receptionist II

add extension numbers, CP 6536

call flow, 1-4

call processing, 2-1

call processing instructions, 2-13, 1-4, 1-9

call processing parameters, 2-2

configuration, CP 6535

defined, 1-1

extensions, 2-19

features, 1-2

interaction with mailbox, 2-18

line group, 2-1

message functions (VoiceMemo), configuration, CP 3301

operation, 1-4, 1-9

set up test configuration, CP 6539

tasks, 1-1

test setup, CP 6540

worksheets, 2-19, 2-20

Reorder tone, 1-8

rerouting calls, 1-2

S

Single-Digit Access

special mailboxes for, 2-19

T

test intermediate attendant call processing, CP 6542

test mailbox treatment types, CP 6541

timing parameter, 2-6

transfer

blind, 1-1

screened, 1-1, 1-5

supervised, 1-1

typical, 1-4

Trunk Treatment Types⁷

connect criteria, 2-17

failure treatment, 2-18

V

VoiceMemo configuration, CP 3301

MITEL MAIL™

Voice Processing Solutions



Release
Notes

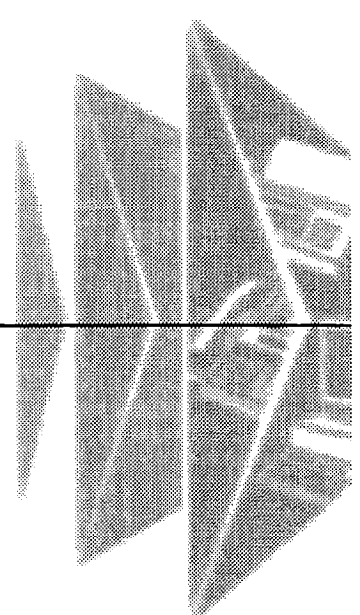

© 1996 Centigram Communications Corporation. All rights reserved.

This publication is protected by federal copyright law. No part of this publication may be copied or distributed, stored in a retrieval system, or translated into any human or computer language in any form or by any means electronic, mechanical, magnetic, manual or otherwise, or disclosed to third parties without the express written permission of Centigram Communications Corporation, 91 East Tasman Drive, San Jose, CA 95134.

REPRODUCTION

Licensed users and authorized distributors of Centigram products may copy this document for use with Centigram products provided that the copyright notice above is included in all reproductions.

PROPRIETARY TERMS

The following are trademarks of Centigram Communications Corporation: AIP, CallText, Centigram, PROSE, SpeakIt, SpeechPlus, SPEECH+, TruVoice, VGS, VoiceMemo

PROSE 2000 Version 1 ©1992 Centigram Communications Corporation.

All other brand and product names are claimed or registered marks of their respective companies.

NOTICE

The information contained in this document is believed to be accurate in all respects but is not warranted by Mitel Corporation (MITEL®). The information is subject to change without notice and should not be construed in any way as a commitment by Mitel or any of its affiliates or subsidiaries. Mitel and its affiliates and subsidiaries assume no responsibility for any errors or omissions in this document. Revisions of this document or new editions of it may be issued to incorporate such changes.

Table of Contents

Preface

Improvements and Corrected Problems

Operating System.....	2
AG8F/AG30 Drivers.....	4
Centrex Integration.....	4
CTI Smartcard Issues.....	4
Ground Start TCP.....	5
Hyatt/Encore/Logistics PMS.....	5
MVIP Clock Configuration.....	5
NEC Integrations.....	5
OneView.....	5
License Numbers.....	5
MESA-Net Prefix String.....	5
OneView 1.1 System Address Book.....	6
Uninstall.....	6
Upload/Download Capabilities.....	6
Phoneline Exception 9 Ringing Timeout.....	6
Phoneline Exception 12 MF Detect Enable.....	6
SMS MWI.....	6
SS7.....	7
SS7 Dial Plans.....	7
ISUP ACM Message.....	8
ISUP IAM Messages.....	9
T1/E1.....	11
UI/ESMDI Integration.....	12
UIMAP Utility.....	12
UI Mailbox Mappings.....	12
Unified TCP/IP Installation.....	13

Known Problem

Originate/Answer Link Conventions In Mesa-Net.....	16
--	----

Preface

This release note identifies features in Centigram Software Release 6.0 that are not currently documented in the technical manuals for this release. It includes:

- Descriptions of improvements and corrected problems
- A list of known problems in this release

Improvements and Corrected Problems

This section describes the improvements and corrected problems in Release 6.0B.

Operating System

IDE Systems

Corrected information to identify IDE systems correctly, not mistakenly identifying them as MCB1 systems

Mailbox Maintenance

Mailbox Maintenance (option C) modified so that previous mailbox function works consistently with next mailbox function. Allows previous function to wrap around end of file or display last mailbox record by specifying mailbox 9999999999 and the use previous function key.

Logfile Menu

Option C in the Logfile Menu (Choose Logfile Serial Redirection) has been changed to allow error log output for each module to be redirected to the specified redirection serial port on its own module.

```
LOGFILE MENU
```

```
(C) Choose Logfile Serial Redirection  
(T) Toggle Display between console and logfile  
(S) Show logfile  
(D) Delete logfile  
(X) Exit
```

```
If you need help later, type ?.
```

```
COMMAND (C/T/S/D/X): c
```

```
Enter filename to save log data = [/usr/vm/log/logfile]
```

```
Redirect logfile output to :
```

(only serial ports which are physically present will be displayed)

- 1: /dev/ser1, serial port 1
- 2: /dev/ser2, serial port 2
- 3: /dev/ser3, serial port 3
- 4: /dev/ser4, serial port 4
- 5: /dev/ser5, serial port 5
- 6: /dev/ser6, serial port 6
- 7: /dev/con1, console
- 8: Clear redirection

Current serial port redirection is: []
Enter number from 1 to 8:

(display that follows is a system having only one active module)

Redirect Serial Port for all modules is set to [/dev/ser2]
Save logfile changes (y/n) ? [N]

(return to display menu options)

(for systems having more than one active module)

The default is to redirect and combine the logfile output of all modules to a single module's serial port. Alternatively, you can elect to redirect each module's logfile output to its own serial port.

Combine all logfile output to a single serial port (Y/N) ? [Y] Y

(display that follows is for the "yes" response)

Redirect Serial Port for all modules is set to [/dev/ser2]
Save logfile changes (y/n) ? [N]

(return to display menu options)

Combine all logfile output to a single serial port (Y/N) ? [Y] n

(display that follows is for the "no" response)

Module 1 Redirect Serial Port is set to [//1/dev/ser2]
Module 2 Redirect Serial Port is set to [//2/dev/ser2]
Module 3 Redirect Serial Port is set to [//3/dev/ser2]
Module 4 Redirect Serial Port is set to [//4/dev/ser2]

(only active modules will be displayed)

Save logfile changes (y/n) ? [N]

(return to display menu options)

AG8F/AG30 Drivers

In RSD 3.1 F, when both AG8F and AG30 drivers were loaded, AG30 failed to load.

Centrex Integration

A new menu to configure message waiting delay has been added to the Offline Menu. From the Offline menu, enter (L) Linegroup and RS232 Applications, enter (C) Centrex, (N) Message notification menu, then (M) Message Waiting Request Interval.

Valid interval range for message waiting delay is 0 - 1000 ms (0 - 1 sec).

Note: Fujitsu 9600 integrations should be set to 1 second (1000 ms).

CTI Smartcard Issues

Users that employ the CTI Smartcard in their configuration should make sure this device is not overloaded. The following table shows the bits per second supported on each port for configurations with 1 to 8 ports

# of ports	Bps supported per port	Comments
1	38400	• Card supports total throughput of 38400 bps for
2	19200	one port or two ports
3	9600	• Data throughput becomes less efficient with the
4	4800	addition of more ports
8	2400	• 1 CTI Smartcard per host limitation

If greater throughput is required, replace the CTI Smartcard with the Serial 16/32 card.

Series 6 servers running revision 6.0A software may be using a port address of 300 and an interrupt of 5. Series 6 systems running with revision 6.0B software must use a port address of 320 and an interrupt of 15, to permit an even broader array of connectivity option.

Series 6 servers with revision 6.0A software will need to remove the CTI Smartcard and modify the port address to 320 and the card interrupt to 15 either prior to or as part of an update to 6.0B software (change on 6.0A and then update or modify during the update process). Centigram recommends that this work be completed prior to the update to simplify the steps involved in the update process.

To do this as part of the update process, do a shutdown then turn off the power on the server, remove the CTI Smartcard, move the interrupt shunt from the 5 position to the 15 position. Then, set the 8 toggle DIP switch as follows:

- 1 off
- 2 off
- 3 on
- 4 on
- 5 off
- 6 on
- 7 on
- 8 on

After making these changes, put the card back in the machine. Install the 6.0B software and include in your configuration process the Smartcard configuration in the Offline Menu. Select interrupt 15 for the CTI Smartcard.

Note: Through the Configure Smartcard Table option of the Offline Menu, confirm that the current Smartcard table reflects the correct configuration (for example,

no cards taken out or moved), then duplicate the current configuration before proceeding with the 6.0B software installation.

Series 6.0 customers who plan to use AT&T Integration and their VBPC card must buy the Serial 16/32 card for their connectivity needs and not use a Smartcard.

Ground Start TCP

Digital Ground Start TCP has been added to Release of 6.0B.

Hyatt/Encore/Logistics PMS

The Hyatt PMS optional feature diskette now gives the option to configure PMS integration. The System configuration menu for Release 6.0 has been modified to display the following:

- (A) Restore COS
- (B) Backup COS
- (C) Configure MWI suppression
- (E) Configure PMS integration**
- (F) Feature COS
- (G) Group COS
- (L) Limits COS
- (M) Restriction COS
- (N) Network COS
- (T) Tenant COS
- (P) Phonenumber Exceptions
- (R) Reconfigure system
- (X) Exit

Limitations

When both EECO and Hyatt are installed on the same server:

- The menu item (E) Configuration PMS integration will appear twice.
- Changes to the Configure PMS integration will affect both the Hyatt and EECO PMSs.

MVIP Clock Configuration

The linecard loader, which was not working in RSD 3.1F for release 6.0, has been fixed.

NEC Integrations

Some calls were not reaching the Series 6 server, which was not receiving some data packets from integrations. Calls are now reaching the server.

OneView

This section describes OneView features.

License Numbers

The license numbers for the OneView applications are now getting created properly.

MESA-Net Prefix String

The users could not clear the MESA-Net prefix string. Placing a zero as the first character in the string clears the prefix string.

OneView 1.1 System Address Book

The OneView 1.1 System Address Book can now be stored on the server.

Uninstall

The capability to **Uninstall** the seats / sessions has been added. Before this release you could not uninstall seats or sessions. A new menu item **M** has been added to provide this capability.

Upload/Download Capabilities

Improved the upload/download capabilities of the OneView remote system by using TCP.

Phoneline Exception 9 Ringing Timeout

Changing this parameter now works for all values between 0 and 255 seconds (time that must elapse, after ringing has started, before the Series 6 server considers the call to be "Ring No Answer.")

Phoneline Exception 12 MF Detect Enable

Phoneline Exception 12 can be set to enable in Release 6.0B. This enables the detection of MF tones (North American Standard).

SMS MWI

The SMS MWI feature of Release 6.0B has a new connection option. This product can now work over a TCP/IP link. The old mode of serial connection is also supported. Following are the new menus showing these Options.

SMS-MWI INTEGRATION

- (I) Current Link Index = [1]
- (N) Module Number = [1]
- (A) Active (Y/N) = [Y]
- (L) Define Login Parameters
- (M) Define Message Parameters
- (P) Protocol CONFIGURATION
- (T) Type of Connection(S=Serial, T = TCP/IP)= [T]
- (C) Connection Parameters CONFIGURATION
- (P) Pager Number = [1]
- (S) Show CONNECTION Parameters
- (X) Exit

Enter 'L' for Login Parameters.

SMS-MWI Login Menu

- (L) Login Name.... = [centigram]
- (P) Password..... = [cgram93]
- (S) System Message = [Optus SMSC]
- (X) Exit

Enter 'M' for Message Parameter

SMS-MWI Message Parameters

- (C) Cluster ID = [1]
- (G) GSM code.. = [01]
- (M) Message Timer (T100) = [1]
- (R) Response Timer (T101) = [3]

- (L) Link Integrity Timer (T102) = [3]
- (A) Retransmission Attempts (N1) = [3]
- (X) Exit

Enter 'P' for Protocol Configuration

SMS-MWI Protocol Configuration

- (S) Send mwi-off long format = [N]
- (C) Checksum checking enabled = [N]
- (L) Do not perform Login sequence = [N]
- (D) Dump log messages in logfile = [N]
- (P) Cut-through-Paging enabled = [N]
- (X) Exit

For serial type of connection, by entering 'C', the connection parameters will be

SMS-MWI Serial Parameters

- (P) Port Name = [\$ctil]
- (B) Baud Rate = [5]
- (X) Exit

For TCP/IP connection, by entering 'C', the connection parameters will be

SMS-MWI TCP/IP Parameters

- (L) Input Port = [1025]
- (P) Output Port = [1026]
- (H) Hostname = [host name]
- (X) Exit

SS7

This release of SS7 incorporates feed back from customer sites on outstanding SS7 issues. These issues which have been addressed in ST12 are

- SS7 Dial Plan issues.
- ANSI Compliance testing.
- Configuration menus.
- SS7 Outdial Functionality.
- Strip Outgoing Zeros.

The new menus are:

- ISUP ACM Messages.
- ISUP IAM Messages.

SS7 Dial Plans.

The following sites should select the following dial plan options.

Site	Dial Plan Option	Notes
E-plus	Cliprefix	Enter appropriate CLI prefix data.
Optus	Sypilnum	Enter Pilot numbers, enable Tollsaver.
Sonofon	Sypilnum	Enter Pilot numbers.

Shinsegi	Syspilnum	Enter Pilot number. Ensure DID mailbox length < Pilot number length.
BellSouth/Chile	Syspilnum	Enter Pilot number.

ISUP ACM Message.

This message is sent from the VM back to the switch in response to an incoming call. The following parameters should be configured for the **Backward Call Indicators**.

Parameter	Menu Letter	Default Value	Chile Value	Notes
Charge Ind	A	2	2	Charge
CLD Prty Status	B	1	1	Subscriber Free
CLD Prty Category	C	1	1	Ordinary Subscriber
End-to-End Method	D	0	0	No end-to-end method available
Internetworking Ind	E	0	0	No internetworking encountered
End-to-End Info Ind	F	0	0	No end-to-end info available
ISDN User Part Ind	G	1	1	ISDN User Part all the way.
ISDN Access Ind	H	0	0	Terminating access non-ISDN.
Echo control device Ind	I	0	0	Incoming half echo control device not included
SCCP Method Ind	J	0	0	No Indication

SS7 ACM ISUP Messages Configuration Menu

- (A) ACM Backward Call Ind Charge indicator ? = [2]
- (B) ACM Backward Call Ind Called Party's Status Indicator?
= [1]
- (C) ACM Backward Call Ind Called Party's Category Indicator ? = [1]
- (D) ACM Backward Call Ind End-to-End Method Indication?
= [0]
- (E) ACM Backward Call Ind Internetworking Indicator's?
= [0]
- (F) ACM Backward Call Ind End-to-End Information Indicator ?
= [0]
- (G) ACM Backward Call Ind ISDN User Part Indicator ? = [1]
- (H) ACM Backward Call Ind ISDN Access Indicator ? = [0]
- (I) ACM Backward Call Ind Echo control device Indicator ? = [0]
- (J) ACM Backward Call Ind SCCP method Indicator ? = [0]
- (X) Exit

ISUP IAM Messages

The IAM menu allows the user to configure parameters in a number of message elements. The parameters and message elements are listed below.

The values to be configured in the **Nature of Connection Indicators** is as follows:

Parameter	Menu Letter	Default Value	Chile Value	Notes
Satellite Ind	A	0	0	No satellite circuit in the connection
Continuity Check Ind	B	0	0	Continuity check not required.
Echo Control device Ind	C	0	0	Outgoing half echo control device not included

The values to be configured in the **Forward Call Indicators** is as follows:

Parameter	Menu Letter	Default Value	Chile Value	Notes
National/International Ind	D	0	0	Call to be treated as a national call
End-to-End Method Ind	E	0	0	No end-to-end method Ind
Internetworking Ind	F	0	0	No Internetworking encountered
End-to-End Information Ind	G	0	0	No end-to-end info available
ISDN User Part Ind	H	1	1	ISDN user part used all the way
ISDN User Part Pref. Ind	I	0	0	ISDN user part preferred all the way
ISDN access Ind	J	1	1	Originating access ISDN
SCCP Method Ind	K	0	0	No indication

The values to be configured in the **Transmission Medium Requirements** is as follows:

Parameter	Menu Letter	Default Value	Chile Value	Notes
Transmission Medium Requirements	L	3	0	3.1k for all systems except Chile which uses speech.

The values to be configured in the **Called Party number** is as follows:

Parameter	Menu Letter	Default Value	Chile Value	Notes
Nature of Address	M	1	3	Default Unique subscriber number, Chile National Number.
Numbering Plan	N	1	1	ISDN numbering plan

The values to be configured in the **Calling Party number** is as follows:

Software Release 6.0B Release Notes

Parameter	Menu Letter	Default Value	Chile Value	Notes
Numbering Plan Ind	O	1	1	ISDN numbering plan
Presentation Restriction	P	1	0	Default restricted, Chile allowed.
Screening Ind	Q	3	3	The config entry is not used in this version.
Nature of Address Ind	R	3	3	National Number

SS7 ISUP IAM Messages Configuration Menu

- (A) IAM Nature of Connection Ind Satellite Indicator ? = [0]
- (B) IAM Nature of Connection Ind Continuity Check Indicator ? = [0]
- (C) IAM Nature of Connection Ind Echo Control Indicator ? = [0]
- (D) IAM Forward Call Ind Nat/Inter Call Ind ? = [0]
- (E) IAM Forward Call Ind End-to-End Method Ind ? = [0]
- (F) IAM Forward Call Ind Internetworking Ind ? = [0]
- (G) IAM Forward Call Ind End-to-End Information Ind ? = [0]
- (H) IAM Forward Call Ind ISDN User Part Ind ? = [1]
- (I) IAM Forward Call Ind ISDN User Part Pref Ind ? = [0]
- (J) IAM Forward Call Ind ISDN Access Ind ? = [1]
- (K) IAM Forward Call Ind SCCP Method Ind ? = [0]
- (L) IAM Tx Med Requirements ? = [3]
- (M) IAM CLD Party Num Nature of Address Ind ? = [1]
- (N) IAM CLD Party Num Number Plan Ind ? = [1]
- (O) IAM CLG Party Num Number Plan Ind ? = [1]
- (P) IAM CLG Party Num Address Presentation Ind ? = [1]
- (Q) IAM CLG Party Num Screen Ind ? = [3]
- (R) IAM CLG Party Num Nature of Address Ind ? = [3]
- (X) Exit

T1/E1

Release 6.0A supported only Common Channel Signaling (CCS) integrations over E1 and Channel Associated Signaling (CAS) integrations over T1 previous to this revision. Release 6.0B provides the flexibility to specify what type of signaling is being provided on each of the T1/E1 trunks in the system. This permits SS7 support over T1 now and will support future channel associated signaling (for example, Mercury Subscriber Line) over Centigram E1 trunks. A new menu choice S—configure Signaling type—has been added to the T1/E1 trunk configuration menu. This menu includes the following three choices:

- A CAS Signaling
- B CCS Signaling
- C none

Feature Use

By default, the system will configure T1 boards added by an administrator to contain two trunks each carrying CAS signaling. The administrator is only to specify which specific signaling protocol is being used on each of the lines. By the default the system will configure E1 boards added by an administrator to contain two trunks each carrying CCS signaling (SS7). This default behavior is the same as previous loads.

The new menu is utilized only if a T1 board is to be used by an SS7 integration or, in the future, when an E1 board is used for integrations such as R2. The selections apply to the following conditions

- A—the lines on the trunk are using channel associated signaling (for example, loop start, E&M, R2).
- B—the lines on the trunk are controlled by a common channel signaling integration (SS7) and the trunk carries an SS7 link in one of the timeslots (timeslot 24 for T1, timeslot 16 for E1).
- C—the lines on the trunk are controlled by a common channel signaling integration (SS7) and the trunk does not carry an SS7 link in one of the timeslots (all 24 timeslots)

on the T1 trunks are being used as VoiceMemo lines controlled by one or more SS7 links present on other trunks).

UI/ESMDI Integration

For UI/ESMDI integration, configure message waiting delay in the UI menu. From the UI menu, enter (P) Define PBX Groups, (P) PBX Features, (L) Message Waiting Request Interval. Valid interval range for message waiting delay is 0 - 1000 ms (0 - 1 sec).

UIMAP Utility

A new UIMAP utility for merging multiple systems to a single 6.00 system and changing mapping information has been added.

Note: For 5.0X to 6.0 conversions in which two or more 5.0X systems are being merged into one 6.0 system, the Conversion utility mentioned in the following section must be run after each Phase II conversion from a 5.0X system. This builds the new UI database incrementally.

UI Mailbox Mappings

A conversion utility has been added to Unified Integration mailbox mapping.

Conversion Utility

(S) Save Mappings
(R) Restore Mappings
(X) Exit

COMMAND (S/R/X):

When the user enters S, the following message appears:

WARNING: To execute this action may keep the system
OUT OF SERVICE for several minutes!

Enter a file name to save mappings or RETURN to quit:

If the user enters a file name, the utility saves all the mappings in the oaa records to that file. The file will be stored in /usr/vm/map directory. This file is needed later to restore mappings to oaa records.

When user enter R, the following message appears:

WARNING: To execute this action may keep the system
OUT OF SERVICE for several minutes!

Enter a file name to restore mappings or RETURN to quit:

If the user enters a file name, the utility will prompt the user with the following message:

Enter a PBX number to modify or RETURN to no change:

The utility will read the file and restore mappings in oaa records and memory.

Note:

- While running, this utility will not be interrupted by control C.

- The utility first checks if uimap is running on the system. It starts uimap if it is not running and terminates uimap when exiting this utility.
- If there is any errors while saving or restoring mappings, this utility will print error messages and terminate.

Unified TCP/IP Installation

The installation for the Unified TCP/IP product requires that the user insert the setup floppy twice, once at the normal time and once after removing Disk 1 of this optional feature. The user is prompted to follow this procedure by the installation software. If this step is ignored, reinstallation of the software will be needed. Note also that Unified TCP/IP requires a reboot of the system after installation and activation.

Software Release 6.0B Release Notes

From the SYSTEM MAINTENANCE - Additional Options Menu, enter a to add optional features. Follow the instructions that appear on the screen. The text that follows shows the messages that appear (bold lettering added):

```
Now installing Unified TCP/IP...
```

```
The software package will be installed from drive: /dev/fd0
```

```
vol: When drive light goes out insert disk 1 and press return
```

```
vol: volume 1 created 27/Jan/96-14:25 by root, 687296 bytes  
used on /dev/fd0
```

```
Restoration complete.
```

```
When drive light goes out, insert SETUP diskette again and  
press return
```

```
Installing TCP/IP protocol stack.....
```

```
WARNING: the Unified TCP/IP records are going to be  
initialized!!
```

```
Type 'CONTINUE' to continue this process. Or, if you already  
have the Unified
```

```
TCP/IP installed, please press ENTER to keep your current  
configuration.
```

```
CONTINUE
```

```
Initializing Unified TCP/IP records.....done!
```

```
cp: Can't open source file. (/usr/vm/config/tcp.init)
```

```
cp: Can't open source file. (/usr/vm/config/tcp.init.0)
```

```
cp: Can't open source file. (/usr/vm/config/tcp.host)
```

```
cp: Can't open source file. (/usr/vm/config/tcp.host.0)
```

[Note: The error messages shown above do not affect the successful installation of the Unified TCP/IP software.]

/usr/vm/config/tcp.host: No such file or directory

Unified TCP/IP Optional Feature is now installed....

Do you want to install another Optional Feature [Y/N] ? N

OFFLINE MENU: configuration 1.

Currently active configuration is: 1.

Reading configuration records...

Checking consistency between hardware configuration and OAA...

Writing new configuration report to
/usr/vm/config/vm.report.1...

Writing new configuration commands to
/usr/vm/config/vm.cmd.1...

TCPIP: writing /usr/vm/config/tcp.init.1

TCPIP: writing /usr/vm/config/tcp.host.1

WARNING: ACTIVATE CONFIGURATION to enable changes!

Known Problem

This section describes a known problem in Release 6.0B.

Originate/Answer Link Conventions In Mesa-Net

In certain configurations, after an activation of configuration or reboot, MESA-Net link assignments changed to earlier or incorrect originate/answer assignments. Link and Port assignment may now be set to configurations other than Centigram conventions for originate links as odd numbers and answer links as even numbers. For ease of service and support, Centigram recommends that the orig=odd, ans=even assignments remain as the convention for link/port assignment.

MITEL MAIL™

Voice Processing Solutions



System
Description

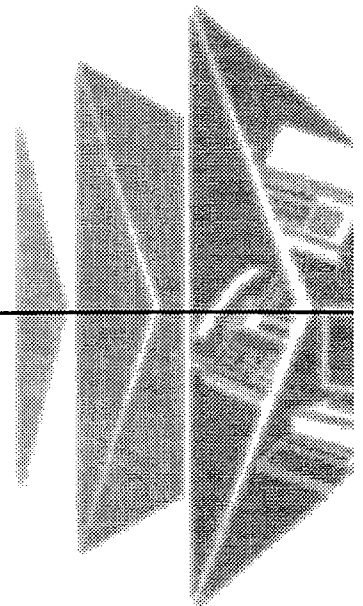

© 1996 Centigram Communications Corporation. All rights reserved.

This publication is protected by federal copyright law. No part of this publication may be copied or distributed, stored in a retrieval system, or translated into any human or computer language in any form or by any means electronic, mechanical, magnetic, manual or otherwise, or disclosed to third parties without the express written permission of Centigram Communications Corporation, 91 East Tasman Drive, San Jose, CA 95134.

REPRODUCTION

Licensed users and authorized distributors of Centigram products may copy this document for use with Centigram products provided that the copyright notice above is included in all reproductions.

PROPRIETARY TERMS

The following are trademarks of Centigram Communications Corporation:
AIP, CallText, Centigram, PROSE, SpeakIt, SpeechPlus, SPEECH+,
TruVoice, VGS, VoiceMemo

PROSE 2000 Version 1 ©1992 Centigram Communications Corporation.

All other brand and product names are claimed or registered marks of their respective companies.

NOTICE

The information contained in this document is believed to be accurate in all respects but is not warranted by Mitel Corporation (MITEL®). The information is subject to change without notice and should not be construed in any way as a commitment by Mitel or any of its affiliates or subsidiaries. Mitel and its affiliates and subsidiaries assume no responsibility for any errors or omissions in this document. Revisions of this document or new editions of it may be issued to incorporate such changes.

Table of Contents

SECTION 1: INTRODUCTION	1
SECTION 2: THE SERIES 6 MODEL	2
SECTION 3: THE TELEPHONE USER INTERFACE	4
3.1 WE SPEAK YOUR LANGUAGE	5
3.2 MESSAGING FOR THE HEARING-IMPAIRED	5
3.3 GUESTMEMO USER INTERFACE	5
3.4 ONLY THE HIGHEST QUALITY WILL DO	6
SECTION 4: MESA-FLEX - MAILBOX FEATURES AND CAPABILITIES	7
4.1 FEATURE CLASSES OF SERVICE (FCOS)	7
4.2 LIMITS CLASS OF SERVICE (LCOS)	8
4.3 GROUP CLASS OF SERVICE (GCOS)	8
4.4 NETWORK CLASS OF SERVICE (NCOS)	9
4.5 RESTRICTED CLASS OF SERVICE (RCOS)	9
4.6 TENANT CLASS OF SERVICE (TCOS)	10
SECTION 5: OUTSIDE CALLER FEATURES	11
5.1 TELEPHONE ANSWERING	11
5.2 AUTOMATED RECEPTIONIST	11
5.3 CALLAGENT	12
5.4 MAILBOX ON DEMAND	14
SECTION 6: MAILBOX OWNER FEATURES	15
6.1 NOTIFICATION	15
6.2 REVIEW MESSAGES	16
6.3 RECORDING AND SENDING MESSAGES	16
6.4 MAILBOX CUSTOMIZATION	17
6.5 ADVANCED SUBSCRIBER FEATURES	19
SECTION 7: MULTIMEDIA MESSAGING WITH ONEVIEW	22
7.1 EASIER AND FASTER MESSAGING	22
7.2 FAXMEMO AND ONEVIEW	23
7.3 SAVING MESSAGES	23
7.4 ONEVIEW REMOTE	23
SECTION 8: APPLICATION MAILBOXES	24
8.1 GREETING ONLY	24
8.2 TREE	24
8.3 CHAIN	24

8.4 ROTATIONAL	25
8.5 BROADCAST	25
8.6 MESA-FORMS.....	26
8.7 SHARED EXTENSION	26
8.8 GUARANTEED FAX.....	26
8.9 WALKAWAY FAX.....	26
SECTION 9: SYSTEM ADMINISTRATION	28
9.1 FUNCTIONALLY PARTITIONED SYSTEM ADMINISTRATION (FPSA)	28
9.2 BILLING AND REPORTING	29
9.3 ADMINISTRATION BY TELEPHONE	30
9.4 SYSTEM BACKUP AND RESTORE.....	31
9.5 MESSAGE PURGE.....	31
9.6 TELNET ACCESS.....	31
SECTION 10: SECURITY	32
10.1 DISASTER RECOVERY	33
SECTION 11: NETWORKING	34
11.1 MESA-NET	34
11.2 AMIS	37
SECTION 12: SWITCH INTEGRATIONS.....	38
12.1 PBX INTEGRATIONS.....	38
12.2 R2 INTEGRATION	38
12.3 SS7 INTEGRATION.....	39
SECTION 13: ARCHITECTURE	40
13.1 THE MESA DESIGN STRATEGY	40
13.2 FUNCTIONAL OVERVIEW	43
13.3 SHARED RESOURCE FAX.....	58
APPENDIX I: CLASS OF SERVICE DESCRIPTIONS.....	62
APPENDIX II: LINE CARD EXCEPTIONS	76
APPENDIX III: LINE CARD INTERFACES.....	83

Section 1: Introduction

Centigram's Series 6 system offers a multitude of unique, user-friendly voice and fax store-and-forward, call processing and multimedia messaging applications. These include VoiceMemo, FaxMemo, CallAgent and OneView respectively. All of these applications are easily accessible from any touch-tone telephone using single-digit commands. VoiceMemo and FaxMemo also may be accessed through any PC using OneView. Some examples of Series 6 applications include:

- Paging a mailbox owner when a new voice or fax mail message arrives
- Scheduling automatic wakeup calls to any telephone at any date and time
- Using the telephone to download a fax message to any fax machine at any time now or in the future
- Recording a voice and/or fax message and having it automatically distributed to thousands of people
- Delivering new, unplayed voice or fax messages to an on- or off-system telephone number of choice
- Faxing a Windows document from a PC with voice annotation to multiple destinations, without using the PC fax modem
- Routing callers to predetermined destinations based on time of day, day of week, or day of year
- Allowing callers to record messages and have them delivered to subscribers without mailboxes

The VoiceMemo, FaxMemo, CallAgent and OneView products are simple in design and operation. The software architecture has been kept simple, so customization and upgrading are not unnecessarily complex or expensive for the user. All of these applications reside on the Series 6 platform.

Four different Series 6 platform models are available to provide communication solutions for businesses:

- Model 70—serves smaller installations with up to 24 ports and 55 hours of redundant speech storage
- Model 120I—serves mid size installations with up to 32 ports and 55 hours of redundant speech storage
- Model 120S—serves large size installations with up to 60 ports and 480 hours of redundant speech storage
- Model 640—provides up to 240 ports with 1440 hours of redundant speech storage/2800 hours non-redundant speech storage

Section 2: The Series 6 Model

Because all of Centigram's application products are supported on the Series 6 platform they can be integrated to provide advanced features and functions. Moreover, all of these features and functions are accessible from the most ubiquitous, user-friendly terminal: the touch-tone telephone. Centigram also offers complete desktop control of voice and fax messages from a windows-based PC.

So what does this mean for the end user?

With the Series 6 system, the end user can retrieve voice and fax mail messages from any touch-tone telephone or PC. If they are traveling or do not have access to their computer, they can listen to their e-mail messages from any touch-tone telephone (using text-to-speech technology), or have them downloaded to any fax machine. Corporate data residing in mainframe computers can be accessed using telephones or facsimile machines 24 hours a day, without the intervention of human operators.

Exhibit 2-1 is a matrix of some of the possible communications solutions enabled by the Series 6 platform. Exhibit 2-2 details the four application products that provide the underlying capabilities for developing these solutions.

Exhibit 2-1

	Voice	Image	Data
Messaging	Voice Mail	Fax Mail	E-mail Access
Information	Audiotext/CallAgent	Fax Publishing	Database Access
Transaction	Voice Forms	Fax Transaction	Database Manipulation
Call Processing	Telephone Answering/CallAgent	Guaranteed Fax	Enhanced ACD
Notification/Delivery	Paging/Off-System Messaging	Fax Broadcast	Database Delivery

Exhibit 2-2

VoiceMemo	<p><i>Offers feature-rich voice store-and-forward functions</i></p> <p>These include voice messaging, telephone answering, audiotext, outdialing functions such as paging, message delivery, mailbox on demand and call placement, and voice forms.</p>
FaxMemo	<p><i>Permits facsimile store-and-forward functions</i></p> <p>Enables users to send, receive, give, answer, voice annotate, and distribute fax messages. Provides for automatic and/or scheduled delivery of information via facsimile.</p>
CallAgent	<p><i>Provides comprehensive call processing and call handling capabilities</i></p> <p>Allows users and administrators to configure applications to answer calls, play messages and route callers (on- or off-system) without human intervention. Provides audiotext customization.</p>
OneView	<p><i>Provides multimedia messaging from a PC</i></p> <p>Enables mailbox owners to use a PC to view all messages in their mailbox and to play, make, answer, give, keep and delete their voice and fax messages.</p>
TDDMemo	<p><i>Provides messaging capabilities for the hearing impaired.</i></p> <p>Works with telecommunications devices for the deaf (TDDs), allowing system prompts to be displayed on the user's TDD screen.</p>
Voice Gateway	<p><i>Provides Full-function Interactive Voice Response capabilities</i></p> <p>Offers online access to any information on any database or host computer with information delivery via digitized voice, text-to-speech conversion, or facsimile transmission.</p>

Section 3: The Telephone User Interface¹

Human factors always have been a paramount consideration in the engineering of the VoiceMemo and FaxMemo user interface. Centigram was the first company to offer mnemonic prompts, an online user tutorial, single-digit prompts and system administration from a telephone.

Mnemonic prompts provide easy-to-remember commands for each step of the call process. In addition, all commands are single digit, and menus are structured to present the most frequently chosen options first. The learning process for new users is accelerated, since it quickly becomes second nature to press "P" to play or "A" to answer a message, for example. Outside callers also can remember multiple menu items better, because keystrokes have a direct association with the corresponding operations. Once the user is comfortable with the prompts, they may override them.

Coupled with a friendly user interface is a mailbox tutorial for every new mailbox on the system. The user is guided through this tutorial the first time they log into their mailbox. During the tutorial, the user learns about all messaging capabilities and customization features available in their mailbox. In addition, the user is led through the process of recording their name, a personal greeting, and a secret passcode. After the initial tutorial is completed, a user can access the tutorial again at any time through the "User Options" menu in their mailbox. If a user does not wish to hear the tutorial the first time they log into their mailbox, the system administrator may disable it.

Since Series 6 system commands are easy to remember, users take advantage of advanced features. Corporate employees who begin by using the system just to take messages discover that, simply by pressing the A key, they can answer messages from other employees, and even hold "conferences" through voice messages. Service providers find they can migrate their customers to increasingly sophisticated levels of service as the customers discover how simple even the advanced features of the VoiceMemo and FaxMemo system are to use.

VoiceMemo and FaxMemo prompts are context-sensitive. After listening to a message, the user can press "A" to Answer it; after recording a message, the user can press "A" to Append to it. During a message playback, a user can press T to go to the Top of the next message; after hearing a fax message has arrived, a user can press T for fax Transmittal options. The experienced user can override prompts with DTMF tones, and even enter an entire string of commands at one time. The Series 6 system retains and executes these commands in the order in which they are entered. Help is always available; the user simply waits for the prompt menu to be replayed. If the user presses an incorrect key, the system issues an informative error message, such as "I'm sorry; I did not understand that command," followed by prompts for the options available at that time.

¹ See Section 7, "Multimedia Messaging with OneView" for an explanation of the desktop user interface.

3.1 We Speak Your Language

In addition to English mnemonic prompts, numeric prompts are available on the VoiceMemo and FaxMemo applications in English, Australian English, British English, New Zealand English, Canadian French, German, Japanese, Korean, Latin American Spanish, Mandarin, Mexican Spanish and Portuguese. Each Series 6 system can offer from three to eleven additional full language sets in addition to English. Prompt languages are assigned by line group, which is particularly useful in international applications. Customers who speak French can be given the pilot number for a line group where French prompts are played, and Spanish-speaking customers can be given a number on the same system that issues Spanish prompts. Prompt languages also may be assigned to individual mailboxes, through the mailbox's class of service.

3.2 Messaging for the Hearing-Impaired

In addition to foreign languages, Series 6 systems optionally offer TDDMemo, which is used with TDDs (telecommunications devices for the deaf). With TDDMemo, every spoken prompt on Centigram's system has been converted to Baudot tones (the tones all TDDs send and receive). This allows system prompts to be displayed on the user's TDD screen. TDDMemo prompts function just like VoiceMemo prompts, telling the user how many new messages they have, instructing them how to perform an action, and allowing users to interrupt prompts and choose an action. TDDMemo prompts require a full-set language slot on the Series 6 system.

3.3 GuestMemo User Interface

Centigram prompts are available in two versions: the regular full-set (described above) and the GuestMemo set for the lodging environment. All systems ship with the full-set prompts, but these may be overlaid with the GuestMemo prompts for hotel or motel customers. GuestMemo prompts differ from the regular full-set prompts in three important ways:

1. GuestMemo prompts are shorter than the full set prompts (since hotel guests do not need to perform all VoiceMemo functions).
2. GuestMemo English prompts are alphanumeric (e.g., "Press P the 7 key to play the first message"). GuestMemo foreign language prompts are numeric.
3. Each Series 6 system can accommodate from 3 to 11 GuestMemo prompt languages in addition to English.
4. GuestMemo prompts in American English are available in both "overlay" and in "standalone" form. Overlay hotel prompts will load on top of American English mnemonic prompts. Standalone hotel prompts require a full language slot on the Series 6.

GuestMemo prompts make it easy for hotels and motels to offer customized service to their guests, through easy-to-use voice mail in their native tongue. GuestMemo prompts can even be played in one language, such as Mandarin, for a guest, and another language, such as English, for an outside caller leaving a message for that guest.

3.4 Only the Highest Quality Will Do

Series 6 systems support high quality prompts, names and greetings. Prompts are available in 24 kbps. Names, greetings, and messages are available in 18.3 kbps, 24 kbps and 32 kbps. Speech and prompt quality can be configured systemwide, on a line group level, or on an individual mailbox level.

32 kbps greetings can be used to provide high-quality company information (audiotext) mailboxes, or service provider bulletin boards. 24 kbps prompts are used to enhance the quality of the user interface, and service providers could price mailbox services differently for mailboxes with differing speech quality.

Section 4: MESA-Flex - Mailbox Features and Capabilities

Centigram has substantial experience selling into both the service provider and CPE markets. Serving both markets has given Centigram a unique insight into the messaging needs of a broad base of user communities, and the different features and capabilities required for their particular business applications. The Series 6 server satisfies these diverse needs through MESA-Flex, a design tool that allows an administrator to define the features and capabilities of a mailbox.

MESA-Flex allows a system administrator to enable voice and fax mailboxes with a unique set of features, capabilities, and parameters. There are over 300 capabilities that can be assigned by MESA-Flex and these may be configured into over 107 million distinct classes of service on a single system. Classes of service and individual features may be changed effortlessly and as often as desired on an individual mailbox level. In addition, these changes can be made online while the system is processing calls.

MESA-Flex provides this design flexibility through six distinct classes of service categories, which can be programmed and assigned independently of one another. These are the Feature Class of Service (FCOS), Limits Class of Service (LCOS), Group Class of Service (GCOS), Network Class of Service (NCOS), Restricted Class of Service (RCOS) and Tenant Class of Service (TCOS).

4.1 Feature Classes of Service (FCOS)

When callers contact the Indianapolis Convention and Visitor's Association they hear a welcoming greeting and are presented with four choices: press 1 on a touch-tone phone to record their address for a visitor's guide mailing; press 2 to hear information on attractions and events; press 3 to hear descriptions of local hotels and, if desired, to transfer to the hotel of their choice to make a reservation; or press 4 to speak to a representative of the association. Callers on rotary phones are automatically transferred to a representative.

All these options can be implemented on any Series 6 system. The Indianapolis Convention and Visitor's Association simply took advantage of the powerful Feature Class of Service (FCOS) capabilities that are part of every system. Every mailbox on the system has a unique set of features that are enabled by feature bits. Based on software release 6.0, the Series 6 system has over 250 different feature bits. These features range from basic user privileges such as the ability to receive messages from outside callers, to specialized operations like fax broadcasting. Combining feature bits creates an FCOS, which defines the capabilities of an individual mailbox.

Centigram's rich FCOS structure means that our customers can create many specialized applications without purchasing new software or hardware. The system does not force you to use a set of preprogrammed choices. Default FCOS are included in the system configuration to allow the system administrator to create mailboxes immediately after the system is installed, but these FCOS definitions can be modified by adding or deleting feature bits. An example is the

Greeting Only FCOS, which plays a greeting to an outside caller (such as movie listings, weather information, or store hours), then hangs up.

Each mailbox on the system can have a unique set of features and capabilities. Fax capabilities (fax broadcasting, fax on demand, fax store-and-forward, guaranteed fax, walkaway fax) and special mailboxes (tree, broadcast, check-in/check-out) are examples of features enabled by feature bits. Every mailbox can be customized with a unique FCOS, which can be changed easily and as often as necessary by the system administrator. If a user's mailbox is assigned to an FCOS that excludes a specific feature, the user will not hear any prompts that refer to that feature.

FCOS is used in one of three distinct ways. First, it is often valuable to differentiate a novice user from an experienced user and to provide advanced mailbox features for experienced users only. This minimizes training and support requirements associated with system implementation. Second, FCOS is often used to match a mailbox to the requirements of a specific application. Examples include rotational mailboxes for audiotext, check-in/check-out mailboxes for lodging, and hands-free mailboxes for cellular phone users. Third, FCOS is used by service providers to build several distinct tiers of messaging service. Each tier has a richer functionality which generates additional revenue for the service provider. Up to 640 FCOS can be programmed to define unique mailbox functionality. Please see Appendix 1 for a list of feature bits by category.

4.2 Limits Class of Service (LCOS)

LCOS defines all of the operating parameters of a mailbox by restricting message, greeting, and outdialing digit lengths. These parameters allow the system administrator to control the use of the system resources. They are frequently used in conjunction with FCOS to build multiple tiers of service offerings. Like FCOS, they can be configured and changed online by the system administrator.

Language prompts (English, Australian English, British English, New Zealand English, Canadian French, German, Japanese, Korean, Latin American Spanish, Mandarin, Mexican Spanish and Portuguese).

Up to 640 LCOS can be programmed to quantify different categories of parameters. A list of these parameters is included in Appendix 1.

4.3 Group Class of Service (GCOS)

The GCOS defines mailboxes with which a user can exchange messages. GCOS provides software partitioning at the mailbox level, without requiring partitioning at the line group level. This class of service category allows the VoiceMemo and FaxMemo applications to be configured as either closed or flexible communities of interest, all served by the same multiline hunt group (MLHG).

There are two types of GCOS assignments: bit-mapped, flexible GCOS that can accommodate multiple member groups within a GCOS, and simple GCOS groups, that only one level of affinity communication.

More than 64 flexible, bit-mapped GCOSs can be programmed. A mailbox can be assigned to one, some, or all of these GCOSs. That mailbox can then exchange messages with any other mailbox that is a member of any common GCOS. As an example, a hierarchy of messaging can be built, so that the president of a company can communicate with any of the senior staff, staff can communicate with the president, with each other, or within the department, but lower level department members can only talk to their senior staff representative, not with the president and not across departmental lines.

Up to 32,000 GCOSs can be built as simple affinity groups. Mailboxes assigned to these GCOSs can only communicate with each other and do not enjoy the hierarchy that was described above. Affinity groups allow the system to be partitioned into "virtual" systems, so that a single system can be shared by many different user communities or organizations. With GCOS, this can be done confidentially and transparently to the distinct user groups.

4.4 Network Class of Service (NCOS)

NCOS works in conjunction with Centigram's MESA-Net digital networking products and allows the system administrator to regulate user access to and priority on the digital network. A mailbox's NCOS controls communications between users in one location with users on a Series 6 system in another location. A list of NCOS parameters can be found in Appendix 1.

4.5 Restricted Class of Service (RCOS)

The RCOS is used to provide NPA/NXX screening, which in turn allows a system administrator to screen all outgoing VoiceMemo and FaxMemo calls (e.g., fax retrieval, auto wakeup, message delivery, paging). NPA/NXX screening takes place at both the toll (central office) level and the area code (long distance) level. And, because system administrators can configure a different RCOS for every mailbox owner on the system, each mailbox can have a different screening configuration. NPA/NXX screening can take place in two different ways:

- Allow users to outcall to any number except those specified in the RCOS
- Allow users only to outcall to those numbers specified in the RCOS

A mailbox owner can be allowed to download faxes to all numbers in the 415, 408 and 510 area codes only, or to all area codes except 515. Alternatively, NPA/NXX can provide additional security enhancements to the Series 6 system by protecting it against toll abuse. Using RCOS, any specified mailboxes can be prohibited from making 976 or 900 calls. In addition, more

flexibility can be given to traveling employees to send messages, faxes, and pages to long distance numbers, versus local employees, who only may need to deliver faxes to an internal extension. With NPA/NXX, system administrators have complete flexibility in designing the appropriate limitations on an individual mailbox basis.

4.6 Tenant Class of Service (TCOS)

The TCOS was introduced in VoiceMemo's software release 5.01. This applies only to systems using the Unified Integration capability, which supports up to 32 different switches and up to 56 different tenant groups to share the same Series 6 system. The TCOS controls what outside callers hear and how they are routed within and across the multiple line groups of a shared tenant application.

Section 5: Outside Caller Features

There are four types of outside caller features: Telephone Answering, Automated Receptionist, CallAgent, and Mailbox on Demand.

5.1 Telephone Answering

An example of telephone answering is when a caller reaches an extension and is transferred to VoiceMemo to record a message. After recording their message, outside callers can be given the opportunity to:

- Replay their message
- Re-record their message
- Mark their message urgent so it is placed in the front of the mailbox owner's message queue
- Have the mailbox owner paged and enter a callback number to be displayed on the pager
- Leave a message for another mailbox on the system
- Be transferred to the operator or any extension on the switch.

5.2 Automated Receptionist

Automated Receptionist II is an optional feature that answers incoming phone calls and asks the caller to enter the extension number of the party they wish to reach. If they do not know the extension number of the party, they can spell out the name on the telephone keypad. Once the extension has been entered, the system will transfer the caller to the desired party's extension.

Calls may be transferred blind, supervised, or screened. If it is a blind transfer, the system hangs up once the extension is dialed. If it is a supervised transfer, the system stays on line until the caller gets through to the desired extension. If the extension is busy or ring-no-answer, the call is pulled back and the caller can choose to leave a message in the called party's mailbox, or be transferred to another extension. A screened transfer is when the called party is forewarned who is calling and can choose to accept or reject the call. Again, if the called party chooses not to answer the call, the caller may leave a message in the called party's mailbox or be transferred to another extension. The options available to a caller (transferring to another extension or leaving messages in mailboxes) are configured by the system administrator.

5.3 CallAgent

CallAgent provides advanced call processing capability for Centigram's Series 6 systems. CallAgent is designed for flexibility and allows you to:

- Design complex call processing applications
- Build powerful automated attendants for your company
- Create customized audiotext and information delivery applications
- Utilize multiple call processing applications on each line group
- Configure every extension with its own unique call processing options
- Create customized department call processing applications
- Program or change your call processing applications at any time using a touch-tone telephone

CallAgent is a powerful tool designed to allow users to build customized call processing applications. In most instances, every department or individual in a company will not require their own call box. Call boxes are primarily used on an exception basis, for those individuals or departments who require special call processing. Users have a number of features to select from to build in their specific applications. The key building block for all applications is the call box, which is described in the next section.

The Call Box

CallAgent's flexibility stems from its modular architecture, which uses combinations of call boxes to build call processing applications. Just as a voice mailbox handles all the voice and fax messaging for the Centigram platform, a call box handles all the call processing. A call box allows users to select any or all of the features needed for a specific call processing application. Call processing applications can be created using one or more call boxes.

Overview

The functionality provided by the call box is divided into the following six segments:

- | | |
|------------------|---|
| Override | If enabled, the override segment will supersede the remainder of the call box and take a predefined action such as transferring to an extension or another call box. |
| Holiday Schedule | Routes callers depending on the day of the year. The user can set up holiday call processing up to one year in advance. Each year the holiday schedule is automatically updated by CallAgent, based on the holidays selected the previous year. |

Weekly Schedule	Routes callers depending on the time of day and day of week.
Greeting	Plays a user-recorded greeting.
Menu	Plays a user-recorded menu a user-definable number of times. This segment will also route callers depending on their single-key or multikey DTMF inputs.
Auto Exit	If no other segment has routed the caller, auto exit will route the caller based on a predefined action.

The picture on the right graphically represents a call box. Every call is processed sequentially through each call box segment, beginning with the first segment, override. If callers are not routed or transferred out of the call box by the override segment, they are passed on to the next segment, schedule. Callers move through the call box until they are processed appropriately. A screen example of the main call box configuration screen showing each of the call box segments is included in the Administration section of the CallAgent Product Note.

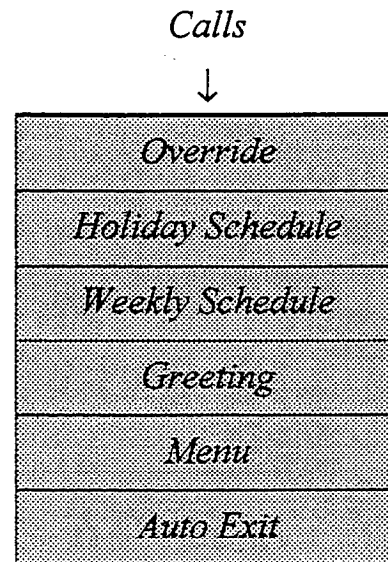

Call Box Actions

Call box actions are the transfer and routing functions available within each call box segment. Depending on the call box segment, certain actions are possible and some are not possible. CallAgent can automatically route callers to call boxes, extensions and mailboxes, or take touch-tone input from the caller and route them to the specified selection. The primary actions available are depicted in the following picture of an "action box" taken from an actual CallAgent screen.

CEX	Callbox
SUP	Supervised Transfer
BLND	Blind Transfer
ALT	Alternate Transfer
SCRN	Screened Transfer
ATND	Attendant
DISC	Disconnect
MBX	Mailbox
UND	Undefined
CONT	Continue in Callbox
DBN	Dial-by-Name

CallAgent Release 1.1 supports the 18.3, 24 and 32 kbps speech compression rates available in Series 6. Users can set the compression rate for each individual call box to improve speech quality. Transfers from the Menu and Auto Exit segments to a VoiceMemo mailbox can now be set to skip the mailbox greeting. CallAgent Release 1.1 also allows administrators to program 10-digit telephone digits through the telephone interface, allowing users to transfer calls to different area codes. Finally, with Series 6, CallAgent billing information is provided through the Enhanced Call Detail Recording (CDR) option.

5.4 Mailbox on Demand

Mailbox on Demand is a feature that allows an outside caller to record a voice and/or fax message for a subscriber who does not have a mailbox, and have that message delivered to the subscriber. The outside caller benefits by having the opportunity to communicate non-real time with a subscriber whom they otherwise would not be able to reach.

This feature is valuable to both CPE and Service Provider customers. In the CPE market, mailboxes could be created on the fly for students who do not have voice mail, guaranteeing that outside callers, professors and other students can effectively communicate with students who are often difficult to reach. In the Service Provider market, mailbox on demand allows callers to leave a message for the mobile subscriber, who by definition is a moving target.

Mailbox on Demand is also a network subscriber feature, and its use as such is described in section 6.5.

Section 6: Mailbox Owner Features

6.1 Notification

Message waiting lights usually are sufficient to notify a user that they have new messages, *if* the user is located next to their telephone. However, there are more and more individuals who do not regularly work at a specific office location or desk. For these people, a message waiting light is not very useful. In response to this situation, Centigram has created numerous ways in which a user can be notified of a new message. These include paging, cut-through paging and message delivery options.

Paging notification allows for real-time notification of voice and fax messages. The Series 6 system supports all commercially available pagers. If the pager is a voice pager, the system will deliver the first 30 seconds of the voice message. It can also send customized alphanumeric messages to paging subscribers. The system supports integration to the widest variety of paging systems via dialup, and most recently, telocator network paging protocol (TNPP).

The system allows for paging customization. First, the mailbox owner can designate up to two primary and two alternative pager numbers. Second, the mailbox can be configured to page at certain intervals or frequencies, or for urgent messages only.

Cut-through paging allows an outside caller or a mailbox user to send a callback number to a digital pager. Normally when an outside caller leaves a message, only the user's mailbox number is sent to the digital display pager. With cut-through paging, a user can circumvent their mailbox and contact the caller directly, using the callback number. The caller also has the option of leaving a voice or fax message in the user's mailbox and leaving a callback number.

Message Delivery is another convenient and timely way to deliver new messages to mailbox owners who work off-site or who are working away from their telephone. If a user decides to work out of their home, they can bypass the need to call into voice mail every hour by using message delivery. The system will call the user at home (or wherever the user preconfigured the system to call) every time a new message arrives. When the phone is answered, the system will prompt, "Hello <user's name>. You have <number> unplayed messages in your mailbox. Please enter your passcode." Once entered, the system prompts the user with the main menu (e.g. "press P to Play your first message, M to Make a new message" etc.)

Like other notification features, message delivery allows the user to set the telephone number, specify the hours available for message delivery, and, through the system administrator, to specify the types of messages to deliver (urgent only, for example).

6.2 Review Messages

After being notified of new messages, a user calls into the system, logs into their mailbox, and hears how many new and saved messages they have. The user then can choose to listen to all, some or none of the messages (urgent messages first, unplayed messages second, and saved messages third), listen to a message multiple times, move forward/backward within the message, pause, or skip to the next or previous message in queue. Once played, any message can be kept or deleted. All messages contain a time and date stamp and the sender's name.

After listening to a message, the user can answer the message automatically without having to hang up or dial another extension. The original message can be attached to the reply to remind the message sender of the subject matter. If the user chooses, they also can give the original message to one or more recipients along with their own comments. All of these options can be configured at the mailbox level, giving the user the ability to customize their own mailbox.

6.3 Recording and Sending Messages

In addition to receiving and playing messages, a mailbox owner can "make" a message and send it to one or more destinations from within their mailbox. Once a mailbox owner requests to make a message, they are asked to indicate the message destination. With the Series 6 system, users can send messages to the following destinations:

- Another mailbox on the system
- A mailbox on a networked system
- An off-system telephone number
- A network subscriber without a mailbox
- A mailbox on another vendor's voice mail system
- A distribution list containing any of the above
- A broadcast mailbox containing any of the above
- Any combination of these

Call Placement allows mailbox owners to send messages to off-system (e.g., non-subscriber) telephone or fax numbers. When the message is sent to an off-system telephone number, VoiceMemo immediately outdials the off-system telephone number and attempts to deliver the message. If VoiceMemo cannot deliver a message on the first attempt, the system will try again at regular intervals for a specified length of time. Both the retry interval and time length can be adjusted by the system administrator. When the call is answered, VoiceMemo tells the answering party who the call is for and who it is from. The recipient may accept, reject, or delay the call. After listening to the message, VoiceMemo allows the recipient to leave a message for

the message originator. In any case, VoiceMemo will notify the caller if the message could not be delivered. If the message is an off-system fax, FaxMemo will not play the above-mentioned prompts.

Mailbox owners can make messages for subscribers who do not have a mailbox on the Series 6 system through the Mailbox on Demand feature. Mailbox on Demand mailboxes can be created by mailbox owners through the "make" function just by entering the subscriber's extension number and recording a message.

In the case of delivering messages to mailboxes on other vendors' systems, the Series 6 system follows the Audio Messaging Interchange Specification (AMIS) standard.

Mailbox owners can send voice and/or fax messages to multiple destinations using distribution lists. Mailbox owners may use both personal and system distribution lists to send messages. Up to 99 personal distribution lists may reside in a mailbox owner's mailbox, and each can contain 65,535 members. Up to 99 system distribution lists with 65,535 members each can reside in an administrator's mailbox (one per linegroup), and can be accessed by mailbox owners on that linegroup.

Broadcast mailboxes can be made available to both mailbox owners and non-mailbox owners to send messages to multiple recipients at one time. Broadcast mailboxes use personal distribution lists to accomplish this.

When a user has finished recording a message, they can review it, delete it and rerecord, or send it. The Series 6 system allows a user to send messages with a number of delivery options. An example would be an urgent message that would be placed at the front of the recipient's message queue. The following are examples of message addressing *delivery options* on the Series 6 system:

- Marking a message urgent
- Marking it confidential (so that it cannot be given to another user)
- Setting it for future delivery
- Requesting a return receipt (to see if the recipient listened to the message)
- Any combination of the above

6.4 Mailbox Customization

Although the system administrator is responsible for creating and modifying mailboxes, the Series 6 system allows users to personalize their mailboxes with the following features:

- Recording a name
- Recording primary and conditional greetings
- Setting the passcode
- Creating personal distribution lists
- Setting a default fax delivery number
- Enabling/disabling automatic fax delivery
- Retrieving all unplayed faxes at once
- Activating the tutorial
- Scheduling message delivery
- Changing a message delivery number
- Scheduling paging
- Changing a pager number
- Activating/scheduling auto wakeup

A mailbox user's name recording is used in several places on the system. For example, when an inside caller reaches a user's mailbox, they first hear the name recording, verifying that they have reached the correct mailbox extension. In addition, when a user logs into their mailbox to retrieve their messages, they first hear their name recording. Finally, when a user retrieves a message, they hear the name recording, identifying the person who left the message.

Users have the option of recording four multiple personal greetings: one primary personal greeting and three conditional personal greetings. The three conditions are *ring no answer*, *busy* and *all calls forward*. When a caller reaches an extension that is not answered, the caller will hear the no answer greeting. If the called extension is busy, the caller will hear the busy greeting, stating that the called party is on another line. When the called extension is forwarded to VoiceMemo, the caller will hear the forwarded greeting, notifying the caller that they have reached the called party's voice mailbox.

Passcode lengths can be 4-10 digits in length, and can be changed as often as a user wishes, through the "User Options" menu. For more information on passcodes, see section 9, Security.

Personal distribution lists are used to send messages to a number of mailboxes at one time. Distribution lists can be changed by the mailbox owner as often as is desired, through the "User Options" menu. Distribution lists are virtually limitless: each mailbox can have up to 99 distribution lists, and each list can have up to 65,535 members.

Setting a default fax delivery number precludes the need to enter a fax machine number to receive a fax. Instead, only one keystroke is necessary to download a fax from a user's mailbox.

If a user enables automatic fax delivery, all fax messages sent to their mailbox automatically will be delivered to their default fax number. These messages also will be stored in the user's saved queue. If the user is going on vacation and prefers not to have his/her fax messages downloaded for a period of time, this option easily can be changed through the User Options menu.

Retrieve all unplayed faxes allows a mailbox owner to download multiple fax messages by pressing a single key in the user options menu. All unplayed faxes in the user's mailbox at that time are concatenated and sent to the user's default fax number.

A mailbox owner can choose to listen to the tutorial at any time by choosing the "activate tutorial" option in the User Options menu.

A user can schedule the message delivery option to any telephone, using single-digit commands. Message deliveries can be programmed to occur at any time or date, and can easily be changed. For example, if a mailbox owner is working at a different location for a day, they can program the system to deliver all of their new or urgent messages to that specified number, obviating the need to constantly check their mailbox for new voice or fax messages.

Users can also choose a paging schedule and a pager number to be notified of all or urgent messages only.

6.5 Advanced Subscriber Features

Automatic Wakeup

If you are having trouble hearing your alarm in the morning, you can schedule a wakeup call from the VoiceMemo system any time, any day and anywhere. If the first call doesn't wake you up, you can program wakeup calls to occur multiple times at specified intervals, until you answer the phone. If this feature becomes habit forming, users can schedule a wakeup call to occur every day on a long-term basis.

Mailbox on Demand

Mailbox on Demand allows network operators the opportunity to provide telephone answering and messaging capability for their subscribers who do not own mailboxes. It can be used in multiple ways, such as:

- Allowing outside callers to record messages for subscribers who don't own mailboxes.
- Allowing subscribers with mailboxes to leave messages for subscribers who don't own mailboxes.

- Notifying subscribers without mailboxes of new “Mailbox on Demand” messages they have received through short message service (SMS), stutter dial tone, message waiting lights, message delivery, paging, etc.

This is accomplished by having the system administrator create a template Mailbox on Demand mailbox (the template with the appropriate classes of service is predefined on the Series 6 system but can be modified) for one or more line groups. Once the template is created, outside callers or mailbox owners can record messages for network subscribers who do not own mailboxes just by calling them. A temporary mailbox is automatically created for the subscriber, and the subscriber is notified of the new message.

Notification can occur in one or more ways, as defined in the template mailbox. It can be through message delivery, in which case the Series 6 system outdials to the subscriber to send them the actual recorded message left by the caller. It can occur through short message service—where an alphanumeric message is delivered to the mobile handset of the subscriber—notifying them that they have unplayed messages and instructing them on how to retrieve them. It also can occur through message waiting lights, stutter dial tone, or other message wait notification options available on the Series 6 system.

The subscriber then logs into the mailbox on demand and listens to the unplayed message(s). At midnight the mailbox is purged, unless there are unplayed messages that are less than two hours old. A new mailbox on demand can be created when another caller dials the subscriber and is unable to reach them. Both of these options are configurable by the system administrator in the template mailbox.

Mailbox on Demand activity is tracked in Centigram’s Call Detail Recorder (CDR) billing package. There are 26 fields which record details of mailbox on demand activity. Information available for usage and/or billing includes:

- Creation of mailbox on demand—including date and time
- Purge of mailbox on demand—including date and time
- Number of unplayed, urgent, and fax messages in a mailbox on demand
- Number of messages played, kept or discarded in a mailbox on demand
- Number of minutes a subscriber was logged into a mailbox on demand

Mailbox on Demand benefits carriers by:

- Increasing the number of subscribers who purchase and use voice mail by easily introducing the concept to them.
- Increasing airtime through increased call completion.

- Increasing airtime by having subscribers without mailboxes call in to get their "Mailbox on Demand" messages.
- Increasing revenues by billing subscribers for messages received.
- Reducing system administration time and costs by having Mailbox on Demand mailboxes automatically created for subscribers, without system administrator intervention.

Mailbox on Demand also allows subscribers the chance to receive messages from outside callers and mailbox owners. When an outside caller is unable to reach a subscriber (the line is busy or ring-no-answer), they are given the opportunity to record a message for the subscriber. A Mailbox on Demand is automatically created, the message is placed in the mailbox, and the subscriber is notified that they have a new message. Mailbox on Demand benefits subscribers without mailboxes by allowing them to:

- Become familiar with the concept of voice mail.
- Become familiar with the concept of fax mail.
- Receive messages from callers who weren't able to reach them real time.
- Have messages delivered to them through message delivery (the Series 6 system dials their number and attempts to deliver the message to them).
- Receive notification that they have new messages.

Section 7: Multimedia Messaging with OneView

OneView for Windows is a client software application that operates with the Series 6 to provide voice and fax messaging on the desktop PC. OneView allows users to manage, create, and review their VoiceMemo and FaxMemo messages from a PC. With OneView, users have complete control over voice and fax messages and can:

- Integrate voice and fax messaging with their PC desktop
- View all their messages instantly
- Play, view, and create compound voice and fax messages
- Deliver faxes cost-effectively using the Centigram server
- Archive messages onto their local PC
- Keep in touch anywhere with remote modem access and message download capability
- Use OLE to exchange Centigram voice and fax messages with other Windows applications

7.1 Easier and Faster Messaging

OneView uses a personal inbox to display all of a mailbox owner's voice and fax messages. At one glance a user can see each message in the mailbox, including information on the sender's name, the message-type (e.g., voice or fax), the subject line of the message, and the date and time of the message. Moreover, urgent messages are flagged with an exclamation point and confidential messages with a lock. From the inbox a user can double-click on a voice message, and OneView will automatically play the message either through a sound card on the user's PC or through any telephone.

In addition to playing voice messages and viewing faxes, OneView provides a number of easy point-and-click functions to help users manage their voice and fax messages. Users can Make, Give, and Answer messages directly from OneView. With a few simple commands users can record a voice message, address it another user, attach a fax, and send the compound message to the recipient.

To help the user address and send messages, OneView utilizes address books and distribution lists. When addressing a message, the user can select a recipient from any of these address books or distribution lists. The distribution lists are the same system and personal distribution lists available to the user through the touch-tone telephone interface. OneView accesses two types of address books: a system address book and a personal address book. The system address book has the names and mailbox numbers of everyone with a mailbox on the local Series 6 system.

The personal address book is where users keep a personalized list of names, phone numbers and fax numbers of colleagues, suppliers and customers.

7.2 FaxMemo and OneView

In addition to viewing fax messages from their PC, OneView improves a user's ability to create and send of faxes. Users can create a fax message from any Windows application and send it to any mailbox on the Series 6 or to any fax machine in the world. OneView eliminates the need for having a fax board in every PC and an analog DID phone line in every office. Users can share the server fax resources on the Series 6.

7.3 Saving Messages

OneView allows users to drag-and-drop messages from the inbox into message folders, where they are saved on the local hard drive or on a network file server. In addition, users can convert a voice message into a standard Windows .WAV file or convert a fax into a standard .TIF file and save it in a local Windows folder. Once in these standard formats, users can embed these messages into any OLE-enabled document (e.g., MS Word, cc:Mail) using the OLE interface.

7.4 OneView Remote

OneView Remote is a new product the allows subscribers to access their messages from their PC using a telephone line and modem. Remote users can call into the Centigram system from any location and have full OneView access to their mailbox. OneView provides two modes of operation for remote users, online and offline. In the online mode, users can directly access their mailbox functions, as they would from a local PC connected to the Centigram system. In the offline mode, users can download the contents of their messages to their local PC and then log off. Their mailbox information is now stored on the local PC and they can manage their messages (e.g., listen to, respond to, delete, keep, make, etc.) offline, at a time and location convenient to them. After completing their messaging activities, subscribers then reconnect to the Centigram system and resynchronize their mailbox.

Section 8: Application Mailboxes

Numerous, tailor-made advanced applications can be designed on Centigram's Series 6 system simply by using FCOS. These are known as application mailboxes. Nine different application mailboxes are described below.

8.1 Greeting Only

Greeting Only mailboxes are used to provide information to a caller, but do not allow the caller to leave a message. There are three types of greeting only mailboxes:

- Voice greeting
- Fax greeting
- Voice and fax greeting

Voice greeting only mailboxes greet all callers with specific voice information (such as weather information or traffic reports). Fax greeting only mailboxes are used by callers to receive faxes on demand. Callers who dial from a phone connected to a fax machine automatically receive a particular fax document, such as the company's annual report.

Voice and fax greeting only mailboxes allow a caller to hear a voice message and retrieve a fax with one telephone call. The voice message can describe the contents to help the caller decide whether to retrieve the fax.

8.2 Tree

Tree mailboxes route calls to pre-selected mailboxes when callers enter a single digit. The single-digit options are announced in the greeting. For example, a company's human resources information number might play a tree mailbox greeting such as "Thank you for calling Company XYZ's human resources information number. Press 1 for benefits information, 2 for job listings, 3 for job applications..."

Tree mailboxes can also be configured to handle rotary dialers. An FCOS bit will automatically route rotary callers to the first or last mailbox in the tree, or transfer them to the operator.

8.3 Chain

Chain mailboxes allow a caller to enter a mailbox number and be transferred to that mailbox upon hearing the greeting. If the caller does not know the number of the party they wish to reach, they can also dial the name of the mailbox or mailbox owner.

8.4 Rotational

Rotational mailboxes allow an administrator to create audiotext applications where callers have one of a number of greetings that constantly change. Greetings change either by time and date (in a period-type rotational mailbox) or with every call (in an index-type rotational mailbox). Rotational mailboxes can be programmed as "greeting only," meaning that after a caller hears a greeting, the phone hangs up. They also can be programmed to allow the caller to leave a message after the greeting.

A movie theater can use period-type rotational mailboxes to inform callers of daily movie features. Callers on Monday hear the regular greeting, the day of the week, the feature film, and the show times for that film. Callers on Tuesday hear the regular greeting and the relevant information for Tuesday's showing, and so on.

Index-type rotational mailboxes are programmed to automatically change the greeting on a per-call basis. For example, retail store might have ten different sales going on at a particular time. Instead of greeting each caller to the store with information about all ten, the system gives the first caller the first sale message, the second caller the second sale message, the third caller the third message, and so on. If the first caller calls the store a second time, they (will likely) hear a different sale message. Rotational, tree and chain mailboxes can be combined or used independently.

8.5 Broadcast

Broadcast mailboxes allow both system users and outside callers to record and send a single message to multiple users. To illustrate the use of a broadcast mailbox, imagine that the manager of a company health club wants club members to know about an upcoming tournament. Instead of leaving messages for every member separately, the manager can log into their mailbox and make a message for the broadcast mailbox. The broadcast mailbox, in turn, sends the message to all of the members' mailboxes.

A broadcast mailbox's distribution list (the club members in the example above) is completely configurable by the system administrator or the end user. Each distribution list can contain up to 65,535 members.

Broadcast mailboxes can be used to send out voice messages, fax messages, or combined voice and fax messages.

8.6 MESA-Forms

MESA-Forms is a voice forms application that gives outside callers the ability to leave messages in a way that simulates written information on paper forms. Applications include order entry, questionnaires, routine requests for information, or an overflow for a busy ACD group. Callers accessing a MESA-Forms application will automatically be moved through a series of pre-recorded questions. The system waits for the caller to record their answer before moving on to the next question. System users who transcribe the responses can log into a single mailbox and hear an uninterrupted sequence of replies.

One example of a MESA-Forms application is a golf course that wishes to schedule tee times. Callers can call into a designated mailbox extension and leave their name, phone number, date and time they wish to play golf, and number of persons in their party. Callers can also have the option of transferring to an attendant in lieu of leaving the requested information, or of transferring to an attendant after leaving the information.

8.7 Shared Extension

This application is commonly used in universities and colleges. One system can be subdivided so that one telephone number accesses more than one individual. When a caller reaches a shared extension, they could hear, "You have reached the American University. To leave a message for Diana Thompson, please press 1. To leave a message for Jim Smith, press 2. To leave a message for George Johnson, press 3." The general greeting can easily be changed and the system can also be configured so that an outside caller does not hear a general greeting.

8.8 Guaranteed Fax

A guaranteed fax mailbox allows the system administrator to create a "never-busy" fax machine application. If a fax machine is busy, faxes are forwarded to a "guaranteed fax" mailbox that receives and stores them, without the caller knowing it. Once received, the guaranteed fax mailbox will attempt to deliver the stored fax to the fax machine until it gets through.

8.9 Walkaway Fax

Walkaway fax allows callers to dial one telephone number and immediately send a fax, without a voice coversheet, directly into a user's mailbox. The walkaway fax mailbox simultaneously listens for fax tone and plays the user's personal greeting. If CNG tone is detected, the mailbox receives the incoming fax. If none is detected, the mailbox prepares to receive a voice message.

Walkaway fax mailboxes can be configured to play the user's normal greeting upon answering or a brief, instructional prompt, followed by the user's greeting. The former is often used for mailboxes that receive both voice and fax messages and fax messages with voice coversheets. In

this situation, the caller reaches the walkaway fax mailbox and hears the user's greeting. The caller can leave a voice message, leave a voice message and append a fax by pressing the Start button on the fax machine, or just send a fax at any time by pressing the Start button on the fax machine.

The abbreviated prompt, which instructs the caller to press 1 to leave a voice message or Start to leave a fax, can be used when the mailbox receives predominantly fax messages. If the caller doesn't take action, they will hear the user's personal greeting. Both options can be used in providing one number voice/fax mailboxes to mailbox owners.

Section 9: System Administration

The system administrator is responsible for creating and maintaining all mailboxes on the system. The Series 6 system allows an administrator to perform the following tasks:

- Use Functionally Partitioned System Administration (FPSA) to enhance system security and establish unique access privileges
- Create, modify and delete mailboxes
- Perform routine maintenance of the software files
- Change the system time and date, when required
- Bill clients
- Run system reports
- Set up systemwide distribution lists and broadcast mailboxes
- Build FCOS, LCOS, GCOS, RCOS, TCOS, NCOS
- Create messages of the day
- Change phone line exceptions
- Configure optional features, such as CallAgent
- Use Alarm Reporting Monitor (ARM) to proactively notify technicians and administrators of possible system errors

The VoiceMemo application comes pre-installed in the Series 6 system with default values. These values can easily be changed through the Series 6 console. The system issues prompts to guide the system administrator. To receive help online, the system administrator can type “?” in response to any prompt.

All ports on the Series 6 system are assigned to line groups. Each line group, in turn, is assigned to a single application, and any programming done for that application applies to every port in the line group. The number of ports in each line group is configurable to adjust for the amount of phone traffic for each particular application.

9.1 Functionally Partitioned System Administration (FPSA)

FPSA adds a much higher level of security to system administrators. FPSA allows an administrator to limit access to operations, administration and maintenance (OA&M) functions on a departmental or individual basis. In addition, with FPSA, customers may offload or resell certain administrative functions to restricted groups within their organizations or within their customer base.

FPSA adds security in five ways. First, it can only be activated or deactivated by a special diskette, which will be shipped upon request. The person who loads the diskette (system superuser) is the one person who has access to the entire system. This person assigns passcodes, user IDs, and access privileges. There is no way to bypass the superuser passcode or to activate/deactivate FPSA without this diskette.

Second, access to any part of the system (administration menus or QNX) is controlled by passwords and user IDs. If a password is not correct or does not match a user ID, the user cannot access that part of the system. Passwords only work for the assigned access privileges: if a user gets into billing and reporting, but doesn't have access to configuration, that person cannot change FCOS, the dialing plan, or other functions within the configuration menu. This means that only people who are trained to perform certain functions on the system can use those functions.

Third, customers can control who has access to batch commands. These are very powerful command strings available at the operating system level. Now batch commands can be made accessible only to those who are trained to use them.

Fourth, superusers can force system administrators to change their passcodes every configurable number of days. This lessens the chance that hackers or outsiders will be able to enter the system and do damage. If an administrator/technician does not change their passcode by the specified date, they will be denied access to all parts of the system.

Fifth, FPSA provides an audit trail (if the audit trail is turned on) every time an administrator enters the system. The trail indicates user ID, name, when the system was entered, which menu was entered, and what action was taken (e.g., created 200 mailboxes, changed billing rates, ran verify). Thus, all actions performed on the system can be traced back to a specific individual.

9.2 Billing and Reporting

The Series 6 system offers four categories of reports that provide comprehensive and detailed information for the system administrator. These reports are very useful in performing billing, diagnostic and usage functions. The four reporting categories are:

1. Statistics—five reports that cover how system resources are used.
2. Billing—four reports that give a breakdown of charges for individual mailboxes, and calculate the total amount due.
3. System information—ten reports that give specific information about how the system is configured or programmed.
4. CDR—an optional report that tracks in detail every voice or fax call made or received by the Series 6 system.

Statistics reports offer the administrator information on usage of line ports, speech storage, trunks, MESA-Net, and messages.

Billing reports give information on the breakdown of charges for individual mailboxes by statistic, then calculate the total amount that is due. The four reports cover current and past billing statistics and statistics on terminated mailboxes.

The system information reports provide details on system configuration, classes of service, system errors, phone line exceptions and pager system access codes.

Call Detail Recorder (CDR) provides a comprehensive amount of detail on all calls made to or from the Series 6 system. With CDR, information such as when a call was made, how long it lasted, whether it included a fax and, if so, how many pages, is available. CDR also records information on fax messages, voice messages, and pager notifications to telephone numbers anywhere in the world. CDR is in standard ASCII text and can be exported to an off-board program for further editing and formatting.

In addition to the above reports, Outdial Billing to Calling Card allows mailbox owners to be billed automatically for outcalls made from the Series 6 system. Both service providers and CPE customers have been asking for an easier, more reliable way to bill back for long distance and toll calls made from the Series 6 system. Long distance and toll "outcalls" made from the Series 6 system include off-system messaging, call placement, auto wakeup, fax retrieval and paging.

With outdial billing to a calling card, all long distance and toll calls are charged to the mailbox owner's calling card at the time of the call. Long distance and toll calls are defined by a new limits class of service (LCOS), which specifies a minimum billed outcall number length. Outcalls greater than or equal to this length are billed to the mailbox owner's calling card.

9.3 Administration by Telephone

- Many of the system administration activities can be done over the telephone. This is quite useful when the administrator is away from the console or is located at some distance from the administrator's work station. Functions that can be performed by phone include:
 - Creating, deleting and modifying mailboxes
 - Changing mailbox passcodes
 - Changing the system clock
 - Getting usage statistics

A number of security features have been added to the Series 6 system to prevent break-in and manipulation from the administrator's mailbox. For example, the system only allows five seconds of response time for each prompt before it announces "no change" and returns to the administration menu.

9.4 System Backup and Restore

Frequent data backups are a very important precaution against inadvertent loss or destruction of data or system information files. The Series 6 system backups are easy because they can be performed while the system is processing calls.

Data can be restored from floppy backups selectively or in its entirety. In the process, all information is restored except speech (e.g., messages and greetings).

9.5 Message Purge

Both voice and fax messages can be purged automatically based on message age. The Series 6 system allows administrators to define different purge limits for each of the following types of messages:

- Unplayed voice messages
- Unplayed fax messages
- Saved voice messages
- Saved fax messages
- Urgent voice messages
- Urgent fax messages
- Voice message receipts
- Fax message receipts
- Paging receipts

These message retention limits may be configured systemwide or on an individual mailbox basis for maximum flexibility.

9.6 Telnet Access

System administrators may login to the Series 6 server through multiple methods. First, they may login through the console using a serial port connection. Alternatively, they may dial up remotely using a modem into a serial port. Finally, administrators of the Series 6 system may administer the system through Telnet access over a TCP/IP network. The latter provides for faster throughput and use of existing local area networks.

Section 10: Security

Centigram has consistently led the industry in providing system security features at the system level and the mailbox level. The Series 6 platform offers a high degree of protection for system management, administration and maintenance, mailbox usage, and access to network facilities, applications and information.

At the record level, all information and database records, regardless of format, are stored on the Series 6 platform in a proprietary Adaptive Digital Pulse Code Modulation (ADPCM) algorithm developed by Centigram. Hard disks are formatted by the factory to accept information through this proprietary encryption method. Additional security is provided for the database through a proprietary file and record format.

At the mailbox level, the first level of security is protection through passcodes. The Series 6 system can be configured to require passcodes on all mailboxes. Moreover, users can be required to have minimum passcodes of up to 10 digits, and this can be changed by the system administrator at any time to a number between 4 and 10. No trivial passcodes (simple series, same as mailbox number, or all same number) are allowed. If the wrong passcode is input when someone is trying to get into a mailbox, the caller must put the correct passcode in twice or the system will hang up. Hackers will not know if the second attempt was correct; callers are not prompted for the correct number of passcode digits nor are they told what was the incorrect entry.

If a high number of incorrect passcodes have been attempted, the system will notify the user at the next login. The system also can be configured to lock a mailbox after a configurable number of incorrect passcodes have been entered. Only the system administrator can unlock the mailbox, set a new temporary passcode, reset the tutorial, and require reinitialization from the integrated telephone number.

Various access limits can be applied to the Series 6 system through the Limits Class of Service (LCOS) to control outcalling capabilities from the mailboxes themselves. Limits can be placed on the number of digits that may be dialed from a mailbox (4 for in-house extensions, 7 for local calls and 10 for paging calls to an 800 number). Limits also can be placed on an individual mailbox session length, causing the system to hang up when the limit is reached. This session limit can be lowered if a system has been threatened by hackers.

Using RCOS, limits can be placed on the actual digits that are dialed (NPA/NXX screening) from a particular mailbox. Screening can take place at both the toll (central office) and area code (long distance) level. In addition, limits can be placed on the interaction between mailboxes through the Group Class of Service (GCOS). The GCOS of a particular mailbox determines if it may interact with any other mailbox on the system. For example, the GCOS could prohibit a messaging mailbox from accessing an audiotext one, or a mailbox on the system from accessing through MESA-Net a remote mailbox on the same system.

Enhanced security is available for all system administration functions on the Series 6 console through Functionally Partitioned System Administration (FPSA). FPSA allows an administrator to create different access privileges, user IDs and passwords for each administrator on the system. Moreover, FPSA provides an audit trail of all system activity and the respective administrator. For more information on FPSA, see section 9.1.

10.1 Disaster Recovery

Centigram offers multiple disaster recovery solutions. First, Centigram maintains at all times a stock of ready-to-ship systems in the event of a natural disaster or a major system failure. Second, Centigram maintains a parts depot on both the West and East coasts. Finally, using MESA-Net, a backup system can be configured in a different location that mirrors in every way the primary system. Reprogramming the switch allows mailbox owners to use the same pilot number to reach their mailboxes, enter their existing passwords, and hear their current name speech and greetings, without ever knowing that they have been moved to the remote system. This function is derived from the Series 6 system's ability to broadcast messages, greetings, name speech and passcodes to one or more remote systems.

Section 11: Networking

11.1 MESA-Net

MESA-Net provides the critical messaging tool that links the members of your team to your company and to your strategic partners. It links multiple Centigram Series 6 voice and fax servers into one, high-speed global messaging network. MESA-Net bridges geographic distances and time zone differences by allowing you to send messages to and receive responses back from your field sales organization, your sister divisions, your suppliers and your customers at any hour, day or night. You can send voice and fax messages to anyone or any group on the network from any phone or OneView-enabled PC. MESA-Net over TCP/IP is a new product available on the Series 6. Centigram's MESA-Net Async product is also available in Series 6, as well as for Centigram systems running software release 5.0X.

Capacity to Spare

Voice messaging systems have been effectively utilized to facilitate communications between people located within single buildings or campuses. MESA-Net extends your communications reach by networking multiple Series 6 servers into a single messaging community. Centigram sets a new high water mark for global messaging capacity. With Series 6 and MESA-Net you can provide voice and fax messaging to a large metropolitan area, a multinational Fortune 100 company, or even a small country. MESA-Net supports links up to 1,500 Series 6 servers, supporting millions of users.

High-Fidelity Messaging

MESA-Net's digital networking delivers high fidelity voice messaging even over noisy transmission lines. All messages are digitally encoded and files transferred from server to server with automatic error detection. There is no accumulative distortion from multiple transmissions.

MESA-Net TCP/IP, which is available in all Series 6 and above platforms, provides high-speed message transfer between servers over standard Ethernet. Net throughput varies depending on the Series 6 model and other network traffic.

Internet Compatible

With the Series 6, MESA-Net can take advantage of your existing corporate network to transport messages from server to server using TCP/IP. This means MESA-Net TCP/IP is fully compatible with the Internet. You can use the Internet or private internet service providers, such as AT&T and MCI, to connect your servers together.

* In the initial release 6.0A the rate of transmission is only 18.5 Kbps

For small, very affordable configurations that have occasional network messaging, MESA-Net supports low-cost, dial-up modems. Depending on your messaging traffic, you can design your network to use analog lines, ISDN, 56 kbps lease lines, or E1/T1 lines.

Interoperate with Third Party Voice Mail

Communicating with suppliers and customers is critical to any business. You can set up your Centigram Series 6 server to use AMIS Analog to send and receive voice messages from nearly all third-party voice mail platforms. In addition, to reduce toll call charges, you can use MESA-Net to forward your messages to the nearest Centigram system, then use AMIS to deliver it to the third-party voice mail platform.

Scaleable Servers

Centigram Series 6 servers are scaleable. You can start with a module system, supporting up to 60 ports (2 E1/T1 connections), expand it to a 4-module system, and then network multiple systems together using MESA-Net to support up to 360,000 ports. Depending on the level of network message traffic and the number of servers supported, you can use a 10 Mbps Ethernet LAN to deliver up to 20,000 network voice messages per day (assuming 30 seconds/message, 18.3 kbps speech encoding).

Minimize Networking Costs

In some cases, Centigram Series 6 servers will be connected via dialup lines (e.g., POTS, switched 56, or ISDN). To effectively minimize the cost of network charges, each Series 6 system can be configured to accumulate messages in a queue until a certain threshold is exceeded, and then send all the accumulated messages at once across the network to their final destination. Different types of thresholds include: number of messages in queue, cumulative number of minutes messages have waited, total length of messages waiting, or time of day. System managers can set each of these thresholds to optimize the balance between cost and delivery delays.

There also are separate queues for normal and urgent delivery messages. The administrator can set lower thresholds for urgent messages, allowing them to get delivered faster. The sender has the option of marking their message urgent or normal. Records are kept on all network messages so appropriate billing or cost allocations can be performed.

Upgrading Basic MESA-Net Networks

Series 6 systems can support both MESA-Net TCP/IP and Async MESA-Net. The Ethernet card and the serial (RS232) card must be installed in separate modules. Network message throughput between high-traffic locations can be improved by replacing existing Async MESA-Net networks with a TCP/IP network. Series 6 servers must maintain a hybrid MESA-Net TCP/IP and basic network configuration until every node has been upgraded to TCP/IP.

MESA-Net Specifications

Series 6 servers support one Ethernet 10BaseT interface and up to 32 RS-232 asynchronous ports. MESA-Net TCP/IP is intended for use with existing corporate wide area networks (WANs) or for connecting several collocated Series 6 servers together.

General MESA-Net Specifications

Series 6	- Basic MESA-Net - MESA-Net TCP/IP - Both MESA-Net Async and TCP/IP (requires two or more modules)
Software Release 5.0x	Basic MESA-Net
Series 6 and Software Release 5.0x Series	Interoperates via MESA-Net Async
Max number of addressable nodes	1,500 (includes MESA-Net TCP/IP, ASYNC, and AMIS Analog nodes)
Message delivery priorities	Urgent or Normal
Network classes of service	64
Queue triggers	- Time of day - Message Length (0 to 65,535 min) - Total message latency (0 to 65,535 min) - Total number of messages (0 to 255)
Other networking protocols	AMIS Analog
Max. aggregate message throughput	Varies depending on system model
Transmission options	Analog line, leased line, T1/E1, ISDN (depends on user provided WAN equip.)

MESA-Net TCP/IP Specifications

Approximate max. number network messages per node	1,000 messages per hour (assuming: 30 seconds/message)
Interface options	- Ethernet (10BaseT) - For Token Ring network connect Series 6 via Ethernet to router or bridge converter
Transmission speeds	10 Mbps transfer rate via 10BaseT (Net Ethernet bandwidth under 1 Mbps)

MESA-Net Async Specifications

Approximate max. number network messages per node	300 messages per hour (assuming: 30 seconds/message)
Interface options	- 16 links of RS-232 per module
Transmission speeds	- Maximum 57.6 kbps per link via RS-232 port - 28.8 kbps, full duplex via V.34 modem connection
MESA-Net Async Parallel Links	8 parallel links (max throughput depends on Series 6 model)

11.2 AMIS

AMIS Analog is a Series 6 system networking application that allows Series 6 systems to communicate with other vendors' voice mail systems. With this optional feature installed, mailbox owners can send messages, receive messages, and answer messages received from remote systems.

Any mailbox owner who has AMIS Analog can make and give messages from the local system to any other systems equipped with AMIS Analog capabilities. Any message that cannot be delivered will be returned to the message maker with a reason for nondelivery. When a message is received from another system, the mailbox owner may answer that message with a single keystroke.

Centigram offers AMIS Analog to send and receive voice messages from nearly all third-party voice mail servers. You can transfer your message via MESA-Net over your low-cost network to a nearby Centigram system and then deliver it to the recipient's voice server over AMIS. Centigram has enhanced AMIS Analog in Series 6 to provide the same universal dialing plan capabilities provided by MESA-Net.

Section 12: Switch Integrations

Switch integrations establish a connection between a telephone switch and the Series 6 system. This connection provides call information for direct or forwarded calls and message waiting signals for the user, and is transparent to both callers and users. When the telephone switch and the Series 6 system are integrated, the two systems interact to give capabilities that neither system could provide alone. For example, an outside caller is automatically forwarded to the personal greeting of the called party, instead of reaching the main greeting and having to re-enter the party's extension. In addition, a caller can return to an operator after reaching voice mail, without having to hang up and redial.

The Series 6 system uses three different methods to integrate with a customer's private branch exchange (PBX) or central office: call in-band DTMF, direct data link, and electronic set emulation. The Series 6 platform also supports two additional integrations with telephone switching networks: R2 and SS7.

12.1 PBX Integrations

- Call In-band DTMF and MF- where the switching system and the Series 6 system communicate with one another using an exchange of tones in the voice frequency band (inband).
- Direct Data Link—where the switching system and the Series 6 system communicate with one another using a special data communications circuit, separate from the voice channel.
- Electronic Set Emulation—where the Series 6 system acts as an electronic telephone within the switching system. The Series 6 system extracts and presents call-related information as if it were a station.

12.2 R2 Integration

Through its R2 integration module, the Series 6 platform provides the interface link between telephone networks and the Series 6 system. The R2 module converts R2 Channel Associated Signaling on 30-channel PCM (E1) trunks (CCITT Rec. G.704) to the Series 6 platform's proprietary analog signaling. It also converts the Series 6 system's analog signals back to the R2 protocol digital signaling for the telephone networks. It demultiplexes and decodes incoming PCM voice lines and encodes, multiplexes, and frames outgoing messages from the Series 6 system into the E1 format. Centigram's R2 integration module conforms to CCITT Q.400, Q.421, Q.440, and Q.441, Fascicle VI.4, supplement no. 7.

12.3 SS7 Integration

Through its SS7 integration, the Series 6 platform also supports the SS7 out-of-band common channeling protocol for data and voice communications between ISDN switches over T1/E1 lines. The SS7 integration terminates the voice channels on 30-channel PCM (E1) trunks (CCITT Rec. G.704). In addition, the SS7 integration provides out-of-band call setup and teardown information to the Series 6 platform. The Series 6 system provides native on-board SS7 digital support. Centigram's SS7 integration conforms to CCITT Q.767, Fascicle VI.9 and ANSI ISUP standards.

Section 13: Architecture

The Series 6 platform is a modular, open, standards-based communications server that allows users to make, send, receive, and answer voice, fax, and e-mail messages from a single mailbox, 24 hours a day, by using a touch-tone telephone or a PC. In addition, users can access any information service—in any format (voice, text, image)—from the same mailbox. The system requires no special environmental conditions, and is compatible with virtually every PBX and switching system. The Series 6 platform can accommodate from 50 to thousands of users economically because of our modular expandable system architecture (MESA) design strategy.

13.1 The MESA Design Strategy

Many voice processing companies have product lines with different models designed to serve specific capacity points. Each system in the product line has to be completely replaced whenever a customer outgrows it. At Centigram, we believe that the investments our customers make in our products are worth keeping. A basic principle of our MESA design is that our systems can be expanded in the field.

Series 6 systems do not have fixed port/storage configurations. New applications, new information formats, new storage and new ports can be added independently. Service bureaus, whose subscribers are charged for the amount of time that messages are stored on the disk, require a greater ratio of ports to storage hours. Corporate customers, whose employees tend to keep messages, typically want more storage. Centigram's MESA design allows our customers to buy only what is needed. All this flexibility is without penalty, since each growth point is designed to be cost-effective when compared to competitors' models that specialize at that system size.

Modular expansion is only one aspect of MESA design. Simplicity, the ability to incorporate the latest technology, and distributed processing are integral parts of the Series 6 platform design—a design that allows us to build the best systems for today and for the future.

Keep it simple

The platform is one of the most reliable communications servers in the industry because it is engineered to be very simple, with redundancy options that ensure unequalled performance and uptime. Each module has only four basic components: the line cards, the CPU, the hard disk drive, and the power supply. Our architecture allows us to have Mean Time Between Failures (MTBFs) well in excess of five years.

Use available technology whenever possible

Series 6 systems are built with commercially available, industry-standard components. We can choose the most reliable hard disk drives, power supplies, and chip sets on the market. Our SCSI

hard disk drives, for example, have a minimum of 150,000 hours rated MTBF; field performance is far higher.

The Series 6 system's design uses an Industry Standard Architecture (ISA) backplane bus, a Multi-Vendor Integration Protocol (MVIP) circuit switching bus, and either an Integrated Drive Electronics (IDE) or a Small Computer Systems Interface (SCSI) drive hardware interface. These common protocols allow our system to accept new technology as it is developed. We have been able to add digital networking, interprocessor communications, and important new software features to the Series 6 platform by taking advantage of the wide range of ISA-compatible cards that can be plugged into our backplane. Improvements in industry standard chips have enabled us to reduce the number of chips needed to perform the same functions, which controls costs and increases reliability. The recent introduction of large-capacity hard disk drives that meet our stringent reliability standards allows us to offer upgrades that double the storage capacity of our systems.

The main processor for each module is either an Intel 80486 or Pentium 100 MHz processor. When necessary, we can upgrade to a more powerful processor within the same family. Improvements in industry-standard chips also make it possible to incorporate Very Large Scale Integration (VLSI) solutions into the Series 6 architecture. Use of the latest technology and fewer chips reduce power needs and generate less heat than individual components, which increases system reliability.

The Series 6 platform uses the QNX operating system from Quantum Software. QNX Software is a driving member of the Portable Operating System IX (POSIX) committee, which sets the standards for hardware-independent operating systems. The QNX software is a 32-bit operating system.

Focus our resources where we offer a unique advantage: in software and architecture

Using industry standard components and technology allows us to focus our development efforts on our unique architecture and software design, leaving component and operating system engineering to the companies that specialize in these areas.

- Centigram has many of the most feature-rich applications on the market today, because our standard software package provides millions of distinct classes of service and contains features that allow applications to go far beyond simple voice messaging. Also, our high density analog line cards and digital connections enable us to add direct DID trunks, T1/E1 circuits, low-power options and a multifrequency (MF) signaling option on the line cards. MF allows us to interface with cellular telephone networks.

Distributed Processing

The Series 6 system's MESA architecture emphasizes distributed processing for the fastest throughput and most efficient use of system resources. Processing occurs at four levels:

1. Module level
 2. Intra-module communication
 3. Line card level
 4. Disk drive interface
- At the module level, the main processor controls multiple port configurations. The module processor controls traffic and tracks resource allocations for all internal processing interactions. MESA-Link, an internal LAN, integrates 4 Model 640 modules together at the CPU control level. MESA-Link enables all modules to operate as a single system through high-level information exchange and inter-process communication (IPC).
 - Within a module, the MVIP bus switches calls between cards. This MVIP bus adheres to the computer telephony integration (CTI) standard. The MVIP bus connects any digital telephony interfaces (such as T1/E1 lines) to the DSP cards, where voice processing occurs. Service cards (such as fax cards) can be assigned to a dedicated port or shared among a group of ports, either analog or digital.
 - Many processing tasks are concentrated in the line cards. Each analog or Digital line card contains its own 386 processor and multiple digital signaling processors (DSPs). The line cards provide: signal processing (speech compression and decompression), DTMF detection, pause compression, and MF tone detection.
 - In the Model 640 system, the Monitor Control Board II manages multiple SCSI interfaces. Each SCSI interface has its own dedicated controller, which manages all disk functions and error checking for each hard disk. The Model 120S can contain up to four SCSI disk drives which are controlled by a plug-in SCSI card. IDE drivers control hard disks in the Model 70 and Model 120I configurations.

Centigram's implementation of distributed processing is unique in the industry. Multiple modules in the Model 640 system are linked together with multiple SCSI buses and the MESA-Link, an internal LAN. The SCSI disks are reliably managed as a single database. Each module processes its own work while having fast, direct access to the common database. Database integrity is maintained by a fault tolerant distributed file system.

A Call Scenario:

When an outside caller dials the Series 6 VoiceMemo message center number, the call rings on a line card port. The line card detects the ringing signal, and relays the event to the module CPU.

The CPU locates the system greeting on the hard disk and transfers the data from the hard disk to buffers on the line card. This buffer is divided into three rotating buffers that fill and empty in sequence, ensuring that the user never hears a pause in the playback of the greeting.

The caller enters the mailbox number in response to the system greeting. The line card recognizes the DTMF input and sends it to the CPU. The CPU interprets the DTMF tones as a mailbox number and locates the personal mailbox greeting on the hard drive. The mailbox greeting is transferred from the hard drive to the line card, where it is played to the user.

When the caller responds to the prompt to record a message for the mailbox, the module allocates space on the hard disk drive to store the message, sets up data transfer between the line card and the hard disk drive, and drops out. The speech is first digitally sampled by the linecard. The line card then compresses this speech and sends it to hard disk drive for storage. This compression can be set for 18.3 kbps, 24 kbps or 32 kbps sampling rates.

When the recipient plays the message, the line card converts the 18.3 kbps, 24 kbps or 32 kbps compressed speech data back into 64 Kbits by a reverse algorithm. The result is expanded to an analog signal, which is sent out the line card port to the recipient's telephone, and the recipient hears the message.

13.2 Functional Overview

13.2.1 The Series 6 Module

The Series 6 system is modular. In the Model 640, a maximum of four modules can be connected to reach the capacity of a Series 6 system. Thus, when a customer outgrows their existing module, they can just add an additional module to it, instead of having to buy a completely new system. Each Series 6 module consists of the following 9 components: (See Exhibit 13-3 for an architectural diagram of a 4-module Model 640 system).

- Central Processing Unit
- Modular Controller Board
- Backplane
- MVIP Bus
- Power Supply
- Hard Disk
- Floppy Disk Drive
- Telephony interface card
- QNX Operating System

Central Processing Unit (CPU)

The CPU subsystem consists of an 80486- or Pentium-based central processor board, with 16-64 MB of RAM. The board plugs into the ISA backplane. In the Model 70 system, the CPU is on the motherboard. Line cards, service cards, and communications cards also plug into the ISA backplane, which provides the interface with the CPU. There are 13 ISA-compatible available slots for each Model 640 module, 11 available slots in the Model 120I, 10 available slots in the Model 120S, and 7 slots available in the Model 70. The backplane accepts many ISA-compatible cards, such as fax cards, line cards, DSP cards, communications cards, and T1/E1 interface cards.

The Model 70 and Model 120I configurations support the PC/AT IDE interface, while the 120S and Model 640 systems support the SCSI interface. A plug-in SCSI adapter card is used as the disk interface in the Model 120S. All CPU subsystems support the 1.44-MB floppy interface. The CPU subsystem includes two serial ports for maintenance purposes. Optionally, a second plug-in card will handle several high-speed RS-232 lines for integration with PBXs and other peripheral device needs.

In addition, the Model 640 system uses the Module Control Board II to manage I/O resources. MCB II components include:

- 4 Small Computer System Interface (SCSI) bus interface controllers.
- External alarm interface
- Audible alarm system
- Four asynchronous RS-232 ports
- NVRAM
- Voltage, temperature, and fan rotation monitors

Backplane

Line cards plug into the backplane, which provides the interface between the line cards and the CPU board. There are 13 slots for cards in each Model 640 module, 12 slots for cards in the Model 120I and Model 120S systems and 7 slots in the Model 70. The backplane is ISA-compatible, and accepts many ISA-compatible cards, such as the CPUs, line cards, fax cards, Ethernet cards and the serial cards used for RS-232 type integrations and networking.

MVIP Bus

The Multi-Vendor Integration Protocol, (MVIP) CTI standard, bus allows telephony board products from different vendors to operator together. The Series 6 platform supports such boards as shared resource fax cards, SS7 Protocol cards and DSP cards.

Power Supply Subsystem

The Model 640 has separate power supplies for the CPU and disk storage subsystems. There are two options for both:

- A 50- to 60-Hz, 110-240 VAC input 500W (nominal), auto-selectable, quadruple-output (+5, +12, -12, and -48 VDC) switching power supply plus a 150W disk storage module power supply.
- A -48 VDC input, 500W (nominal), quadruple-output switching power supply (+5, +12, -12, -48 VDC) switching power supply plus a 150W disk storage module power supply.

The Model 120I and Model 120S configurations provide the following single power supply options:

- A 50- to 60-Hz, 100-120 VAC, 500W
- A 50- to 60-Hz, 200-240 VAC, 500W

The Model 70 configuration provides the following single power supply options:

- A 50- to 60-Hz, 100-120 VAC, 200W
- A 50- to 60-Hz 200-240 VAC, 200W

Auxiliary Equipment Subsystem

The auxiliary equipment subsystem can consist of external devices for the Model 640 system such as the CSO/IO module for switching to redundant systems resources, automatic contact-closure monitoring devices, proprietary PBX or standard signaling integrations, or serial interfaces.

Hard Disk

Hard disks provide storage for the operating system, system software, mailbox and message statistics, and digitized speech. Centigram aims for the highest reliability on hard disks, by qualifying them through a rigorous burn-in and testing process. Our hard disks must meet a minimum MTBF of 150,000 hours. At least two sources are qualified for each hard disk size.

Floppy Disk Drive

All Series 6 systems are equipped with a 1.44 Mb formatted (2.0 Mb unformatted) floppy disk drive that uses 3.5" double-sided, double density diskettes. The floppy disk drive is used to install, reconfigure, and update system software, to back up mailbox and account data files, and to upgrade the storage capacity of the hard disk.

Line Cards

Line cards provide the interface between the Series 6 system and telephone lines from a PBX or central office trunk. Line interfaces can be either analog or digital trunks. (See Appendix III for a list of line card interfaces supported by the Series 6 platform). The phone line exceptions program and the algorithms for digitization and speech compression are stored on the line card.

Line cards monitor all of the telephony events that occur on the network. The line card runs software that interprets events based on the signal pattern that the line card receives. The event can be a busy signal, a ring-no-answer, a reorder tone, or a human voice. The program also allows the line card to detect silence and pauses. The parameters used to interpret these events are based on North American signaling practices. They may need to be adjusted to comply with parameters, such as those found in SS7, used in other countries (see Table 4).

Analog

A. Direct Inward Dial (DID): The ability for a caller outside a company to call an internal extension without having to pass through an operator or attendant. At the Central Office Switch The Area Code and Prefix are stripped once the number is identified as a DID telephone number assigned to a company.

B. E&M Signaling: A pair of wires that connect two PBXs or a PBX to a remote extension over a voice grade line. The "E" lead or EAR, receives an open or ground signal from the far end and the "M" lead or MOUTH, transmits a ground or battery condition to the signaling equipment. A -48 voltage change on the leads indicates information such as seizure to transmit, recognition of seizure, release of circuit, dialed digits, etc. Of the 5 types of E&M signaling, Centigram supports type I and type II.

C. Ground start: A two wire circuit that uses grounding methods to form connections. A momentary grounding on one side of a two wire trunk, usually on the ring conductor, of the tip and ring, will establish dialtone. A ground start trunk initiates an outgoing trunk seizure by applying a maximum of 550 ohms resistance to the tip conductor of the tip and ring. Switching equipment and telephone circuits must match to operate correctly with each other.

D. Loop start: A two wire circuit that forms a loop when a station goes off-hook to answer a ring event. The ringing event is trigger by the central office sending AC voltage to the ringer of a telephone. When the telephone handset is removed from the cradle, a DC loop is formed. This action bridges a resistance of the tip and ring, both wires, of a telephone line. The central office recognizes the DC loop and discontinues the ringing event to the set.

Digital

T-1 Signaling: A digital transmission link standard used by the United States, Canada, Hong Kong and Japan. A T-1 link has 24 channels that operate at 64Kbps each for a total of 1.544 megabits per second capacity.

E-1 Signaling: The European Digital transmission link. An E-1 has 30 channels for transmitting voice data at 64Kbps per channel, plus a 64Kbps for signaling and a 64 Kbps channel for framing and maintenance. The E-1 carries information at a rate of 2.048 megabits per second.

Line Parameters

The VoiceMemo application's console program provides a menu-driven interface for configuring line parameters. Appendix II lists some common phoneline parameters that might need to be reconfigured for countries other than the United States.

A silence-detection algorithm in the line card software eliminates pauses at the beginning of, during, and after speech recordings and reduces storage requirements. The algorithm identifies silence even on a noisy line. If necessary, Automatic Gain Control (AGC) increases the sound level of the speech when messages are played back.

Different types of line exceptions are described below. For a list of most used line exceptions, see Appendix II.

- Timeout parameters—Line exception timeout parameters help control port usage by minimizing the amount of time between call processing events. Each of these line exceptions is set to a value that ensures successful completion of the first event, without allowing excess time to elapse before the next event begins.
- Incoming signal detection—Line card ports use these line exceptions to monitor the telephony interface and detect incoming signals.
- Output signaling adjustments—These line exceptions control the signaling and tones needed to dial out for pagers, message delivery, and off-system messaging applications.
- DTMF detection—The Series 6 system receives events in the form of DTMF tones. Some aspects of DTMF detection can be customized for individual line card ports.
- Greet command parameters—The greet command, used for call progress and line signal monitoring, is a general purpose software routine resident on the line card. It detects speech, recorded announcements, dead lines, and call-progress tones such as ringback, busy, and reorder. When the Series 6 system application software instructs a line card port to “wait for a greeting,” the greet command uses digital signal processors to detect tones and speech.

- Speech and silence detection during recording—These parameters work together to detect speech pauses. They stop the system recording when a pause has occurred and restart the recording process once speech has resumed. This function can be enabled or disabled.

Serial Ports

The Series 6 platform supports serial ASCII access for maintenance via any of the serial ports. An outboard modem is used for remote maintenance functions and is connected via a serial port. The CPU in each model supports two serial ports. The Model 640 has four additional serial ports on the MCBII board. The Model 120I, Model 120S and Model 70 need an additional serial card to support more than two serial connections. Maintenance normally is performed using either a serial VY100 compatible terminal or a personal computer with VT-100 terminal emulation. Up to 16 terminals (4 per module on an Model 640) may be connected at one time. A terminal is connected to serial port one and the outboard modem can be connected to any of the remaining serial ports.

The QNX Operating System

Centigram's ability to grow its platform modularly and distribute processing among its components is due, in large part, to its operating system. The Series 6 platform uses the QNX operating system. QNX has a modular design that can control all system real-time functions and applications without the need for outside processors. Operating system functions such as file handling, network management, device I/O, and other functions, are performed by a series of accessible modules known as server tasks. These tasks communicate with each other through a technique known as message passing, where a block of data (the message) is copied from the data space of one task to that of another. A microkernel provides synchronization of task switching and message passing. QNX switches between tasks many times per second, and the switching is controlled by a process called "prioritized event scheduling," which ensures that the most important tasks get CPU processing time when needed.

Exhibit 13-1: Module Architecture

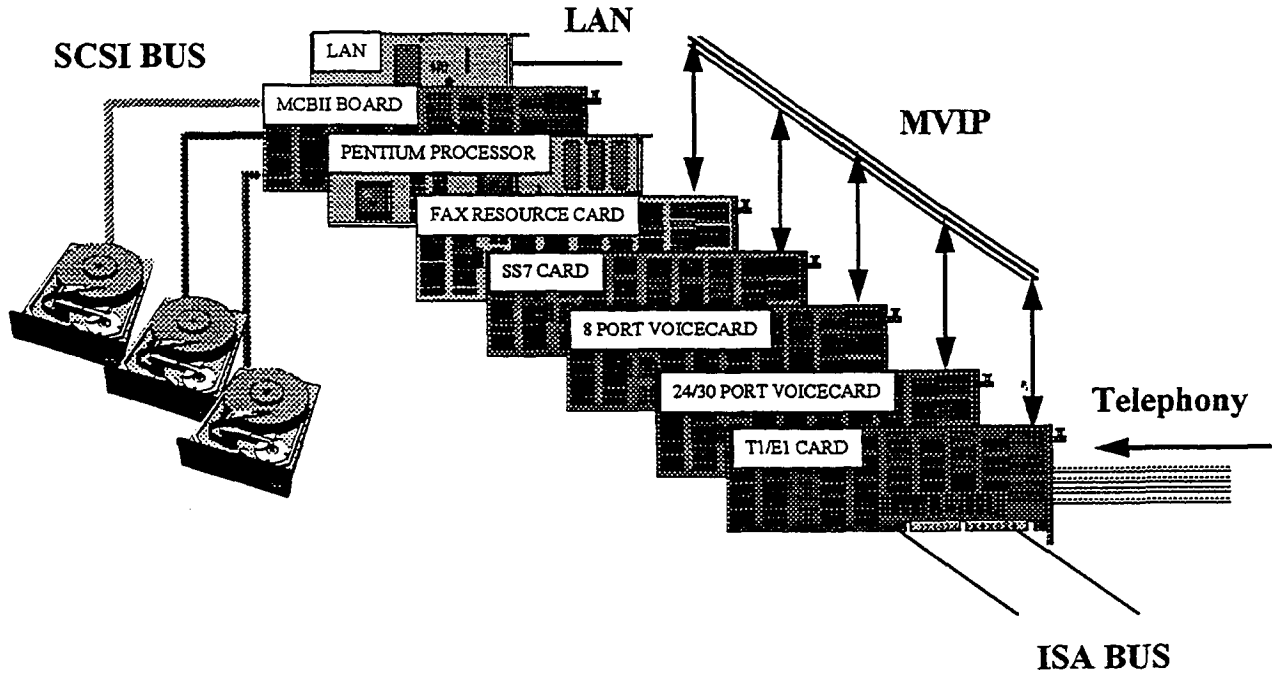

13.2.2 Packaging Options

The Series 6 system is available in four different packaging options: the Model 70, Model 120I, Model 120S, and the Model 640 system. Exhibit 13-2 below outlines each system's specifications.

Exhibit 13-2: System Specifications

Specification	Model 70	Model 120I	Model 120S	Model 640
Number of Ports	4-24	4-32	8-60	8-240
Hours of Speech Storage:				
Redundant	10-55	10-55	10-480	10-1440
Non-redundant	10-55	10-55	10-480	10-2880
Cabinet Size:				Per Module:
Height	6.25"(15.92 cm)	25.5"(64.8 cm)	25.5" (64.8 cm)	36.75" (93.34 cm)
Width	16.35"(41.65 cm)	7.35" (18.7 cm)	7.35" (18.7 cm)	17" (43.18 cm)
Depth	16.75"(42.6 cm)	16.5" (41.9 cm)	16.5" (41.9 cm)	12" (30.5 cm)
Weight	21 lbs (9.5 kg)	25 lbs (11.34 kg)	25 lbs (11.34 kg)	121 lbs (56.36 kg)
Heat Dissipation	680 BTU/hr	1700 BTU/hr	1700 BTU/hr	3475 BTU/hr per module
Operating Temperature	50° F to 95° F (9° C to 35° C)	50° F to 95° F (9° C to 35° C)	50° F to 95° F (9° C to 35° C)	40° F to 100° F (10° C to 40° C)
Non-Operating Temperature	35° F to 120° F (2° C to 49° C)	35° F to 120° F (2° C to 49° C)	35° F to 120° F (2° C to 49° C)	35° F to 120° F (2° C to 49° C)
Relative Humidity: Operating	85% at 95° F noncondensing	85% at 95° F noncondensing	85% at 95° F noncondensing	20% to 55% noncondensing
Agency Approvals	UL, CSA, FCC Parts 15 & 68, DOC, EN60950, CSIPR22	UL, CSA, FCC Parts 15 and 68, DOC, EN60950, CSIPR22	UL, CSA, FCC Parts 15 and 68, DOC, EN60950, CSIPR22	UL, CSA, FCC Parts 15 and 68, DOC, EN60950, CSIPR22
Power Input	110/220 VAC only	110/220 VAC only	110/220 VAC only	110/220 VAC or 48 VDC

A. Model 70

The Model 70 PC-style desktop chassis sits conveniently on a surface and is ideal for small areas. This system consists of:

- An Intel 486 DX66 CPU motherboard with 16 MB system memory, 200 watt power supply and a floppy disk drive.
- Up to two hard disks (IDE interface), which stores system software, prompts, messages, mailbox account, and database information for a maximum of 55 hours of redundant storage.
- Up to 7 full slots are available and a maximum 24 ports can be configured.

The system can be expanded from the basic 10 hours/4 ports by adding ports or by installing ports and storage hours.

Exhibit 13-3: Model 70

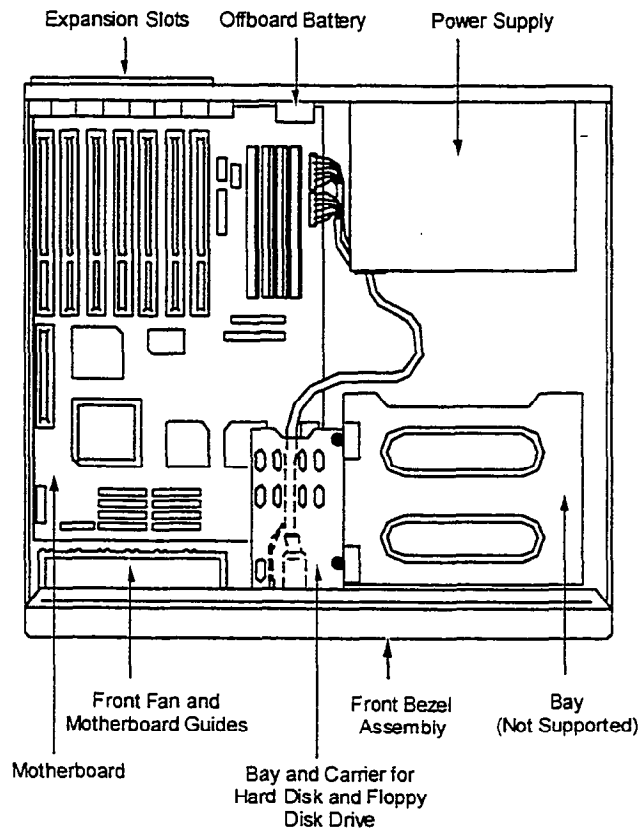

5106a70c

B. Model 120I

The Model 120I system is housed in an upright floor-standing PC-style tower. It consists of:

- A 486SX33 Plug-in CPU and a backplane that supports up to 11 available slots, with a maximum of 32 ports.
- Its hard disk interface is IDE and can support up to two hard disks for a maximum redundant speech storage capacity of 55 hours.
- It also includes a floppy disk drive and an internal power supply.

C. Model 120S

- The Model 120S consists of a Pentium-100 Plug-in CPU and a backplane that supports up to 10 available slots, with a maximum of 60 ports. Its hard disk interface is SCSI and can support up to 4 hard disks for a maximum redundant speech-storage capacity of 480 hours.
- It also includes a floppy disk drive and an internal power supply.

The system can be expanded by adding ports or by installing both ports and storage.

Exhibit 13-4: Model 120

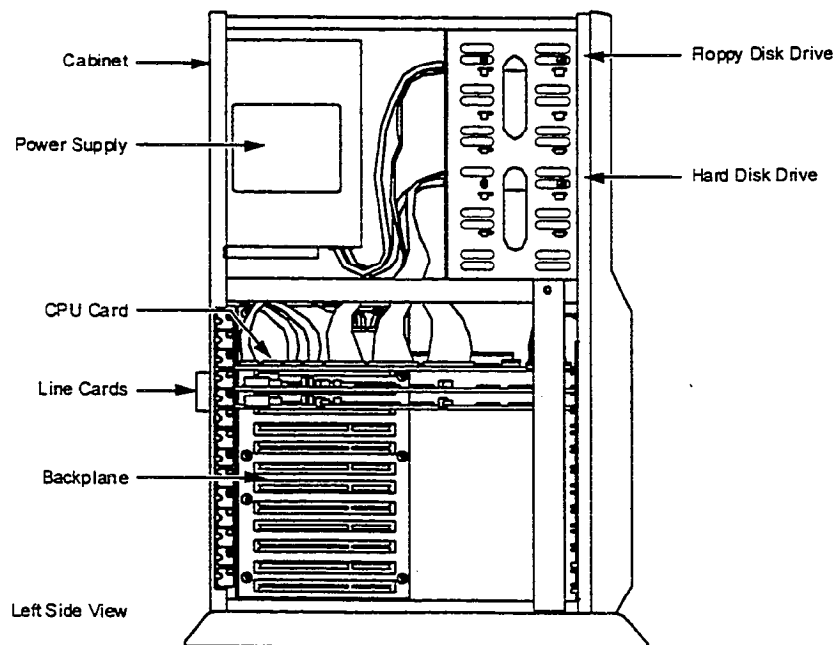

AI120I.EPS

D. The Model 640 System

Centigram's MESA design strategy has evolved to include individual assemblies for each component type. The result is the Model 640 (see Exhibit 13-5). The base Model 640 system consists of:

- A storage assembly with one hard disk, one floppy drive
- A CPU assembly that includes a backplane and up to 15 card slots
- A power supply assembly with a single power supply.

The power supply and storage assemblies have their own cooling systems. All assemblies are designed for mounting on standard 19" telephony racks.

Individual power leads run from the power supply assembly to the CPU, and to a low voltage sensor located on the CPU board. A SCSI bus connects the CPU and the hard disks. The floppy disk drive is connected to the CPU by a separate standard bus.

The Model 640 is the optimal configuration for expansion, since the base system uses only a small portion of each cabinet.

- The disk storage assembly can house up to four hard disks and one floppy disk drive, giving a maximum storage capacity per module of 1440 hours redundant/2880 hours non-redundant. Also housed in the disk storage assembly is a 150 watt power supply which supplies power to all of the drives.
- The CPU assembly holds a single CPU board, a backplane, and can support a maximum of 60 ports per module.
- The power supply assembly holds a 500 watt power supply, which provide enough power to service one full CPU module loaded with the maximum number of cards. It is capable of monitoring system functions such as fan operations, temperature, and power source fluctuations.

Exhibit 13-5: Model 640

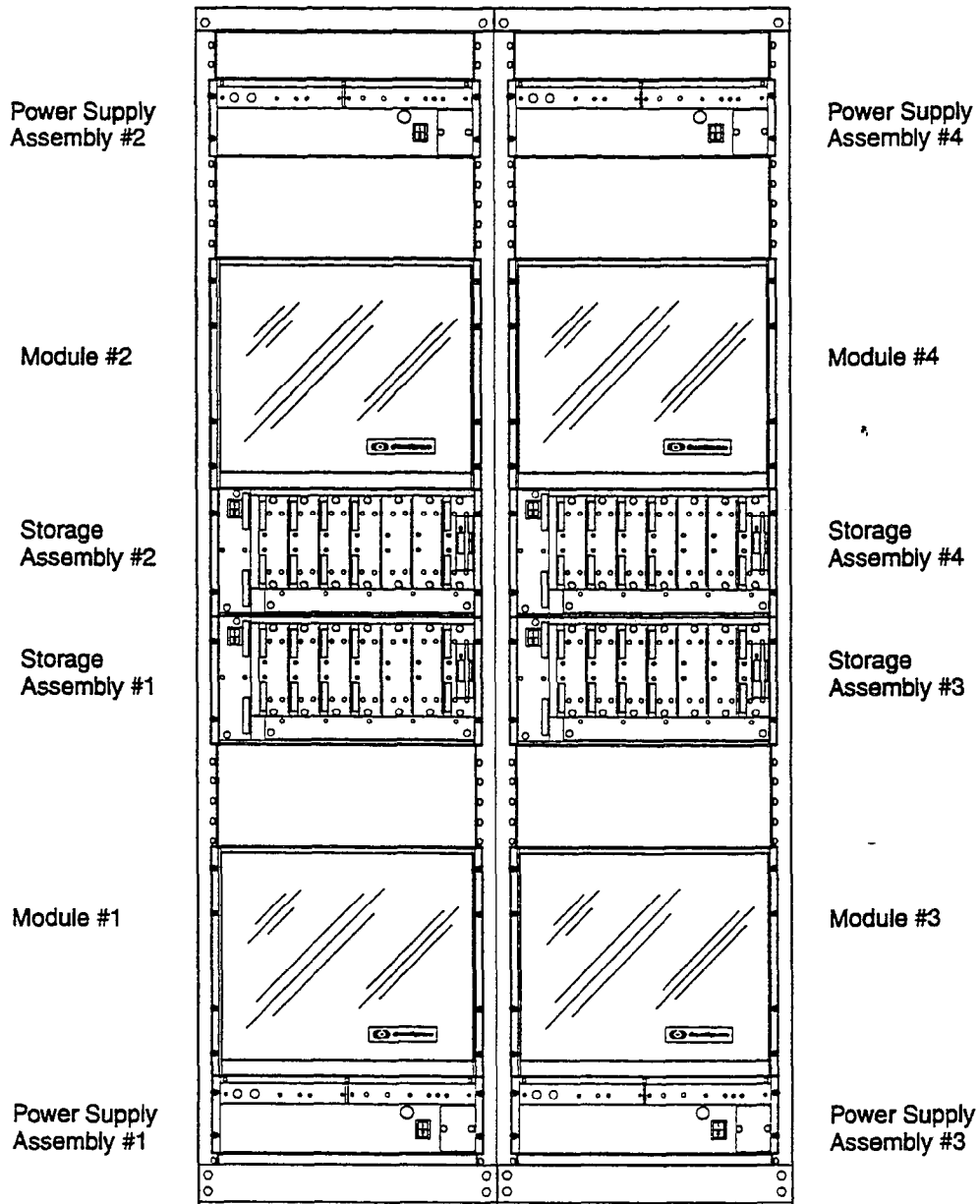

x1937vm6

D.1 Multihost Operations

What happens when we take the architecture and expand it across multiple modules? When we build a large capacity system, or grow a 60-port system to a 240-port system, all modules operate as a single system with a single database, not a virtual single database created by networking separate systems together. QNX has built-in peer-to-peer networking, which allows the setup and control of tasks on any processor across the network. Whether the tasks are executing on the same processor or on physically remote processors does not matter. Centigram's MESA architecture takes advantage of the capability by distributing processing tasks between microprocessors on the line cards and on the CPU. In addition, on a multimodule system, an entire bus (the MESA-Link bus) is reserved exclusively for CPU-to-CPU message passing.

The MESA-Link bus acts as a high-speed LAN that transmits all control functions between the master and slave modules. This maintains central control over the distributed processing functions in a multimodule system. All communications between disk drives and line cards, including database information and speech information, occur over the SCSI bus. The speed of the MESA-Link bus, carrying limited control information, ensures that multimodule systems perform as efficiently as a single module system. For fault-tolerant needs, a second MESA-Link bus is added to ensure that CPU to CPU communication is uninterrupted.

Ports on a multimodule Model 640 system have equal access to system resources, no matter where they are located. Running on the main module processor is a program called "Master," which remembers where all information is located on the hard disk. In a multimodule system, this program resides on the primary module. When a call comes in on a line card, the line card tells the module, "This is a call for mailbox 569." Master downloads the information needed to process the call onto the line card. If a call comes in on the second module for the same mailbox, the second module sends a message to the first module over the MESA-Link bus. Module 1 sends a copy of the necessary information on mailbox 569 to the second module, also over the MESA-Link bus. The second module now knows where all the pointers are, and it can set up a data transfer between the line card in the second module and the common hard disk across the extended SCSI bus. Master is updated in real-time as changes are made in mailbox parameters and/or pointers.

This dual-bus operation is in contrast to pure networked systems, which do not have the extended SCSI bus. The following is an example of a pure networked system: A call comes into the Module 1 line card port, but the information needed resides in Module 3. The line card port in Module 1 speaks to the CPU in Module 3. The information is retrieved from the hard disk drive in Module 3 by its CPU. The information is transmitted back across the local area network to the CPU in Module 1. The line card in Module 1 pulls the data from the CPU's RAM in Module 1. Access to a disk comes through a line card in that module or through the CPU. This type of design requires multiple database manipulation and support.

Centigram's architecture allows the system to work from a single database. Any line card can talk directly to any disk in the system to deposit or retrieve digitized speech, without having to go through a tier of module processors that either buffer the speech, or control each separate disk.

Primary module intervention is required only when information is added to or deleted from a hard disk. This makes real-time processing possible even at the highest traffic levels, when all ports are active at the same time.

Continuous System Operation (CSO) software provides a redundant "hot" standby of all primary module "master" programs. These programs will reside on the second module and be switched over as the "active" master programs for the remaining modules if the primary module fails. The hardware component of CSO is the I/O module which monitors the primary module, and should a fault be detected, it will move the hardware connections to the back-up module. Hardware connections include the console, modem, printer, and a datalink switch integration.

D.2 Fault Tolerance

The Model 640 platform has a high degree of fault tolerance when configured with its Continuous System Operation (CSO) option, Redundant Drive option and the Alarm Monitor Power Supplies (AMPS). There is NO single point of system failure in the architecture. The platform multimodule packaging confines failures to the module level.

A failure affects only a CPU module. With 4 modules composing a 240-port system, only 25%, or 60 ports maximum, will be put out of service. Even multiple CPU module power failures will not take out the total system.

A failure of a disk storage module power supply will put its disk module out of service, but with disk redundancy, the redundant disks—residing in other disk storage module—will run the system without loss of functionality or system resources.

Any module has direct access to any disk, including its redundant disk, that resides on a redundant bus. The Series 6 platform does not require any functionality in adjacent modules. Most other vendors' systems require messages to go over a system bus between modules to access disks that are packaged with line cards. This type of architecture requires at least one other system bus and processors in both modules to function in order to pass messages between modules.

The ISA bus is implemented at the CPU module level with up to 15 cards plugged into the module ISA bus. There is no systemwide bus that all the cards plug into; therefore, there is no bus failure that can disable all the cards. Many competitors have a systemwide bus that can fail and disable all cards on that bus, EVEN redundant CPUs.

The MESA-Link bus is redundant and used for CPU-to-CPU communications. Two MESA-Link cards plug into each module. The ISA bus in each module is isolated from the systemwide MESA-Link buses. A MESA-Link card failure will not disable the module in which the MESA-Link card failed.

The Model 640 platform software does NOT have a single point of system failure that will disable the entire system. The Continuous System Operation (CSO) option will use the

processors in each module as functionally redundant system processors. There will be a STANDBY copy of all System Resource tasks on a CPU in another module as a backup to the CPU of the ACTIVE Primary module. If the Primary module goes out of service, the Continuous System Operation software will activate the STANDBY system resource tasks for use by all other line card modules within 5 to 40 seconds. In conjunction with the I/O module, resources will also move the standby module.

D.3 Hard Disk Redundancy

Since hard disk drives are electro-mechanical devices, they are more prone to failure than circuit boards and chips. A drive failure is also the most serious type of system breakdown, since irreplaceable stored speech and data are lost, rather than simple functionality for the time it takes to replace the part. For this reason, Centigram offers full hard disk redundancy across the Series 6 platform.

When redundancy is configured, the system writes to both hard disks, one immediately after another, in a technique called "shadow writing." To guarantee integrity between the primary and redundant disks, whenever the VoiceMemo application writes to a redundant disk pair, whether to store a message or to record a change to the database, both disks must confirm that the task is finished before the controlling application registers the task as finished. If one of the disks does not report back to the application, the application will retry the operation. If the retry fails again, the faulty disk will be put out of service. A deactivated hard drive can be removed from the drive storage module and a new hard drive inserted while the system continues to process calls. "Hot" pluggable hard drives enhance the redundancy feature on the Series 6 Model 640.

The Series 6 system recognizes the difference between a primary and a redundant disk, but the system does not always read from the primary hard disk, even under normal operating conditions. Both primary and redundant disks are "mirrored" in that they contain the same information. Thus, if a traffic queue starts to build up to a primary drive, the system automatically forms a connection to the secondary drive, processes the call, then shadow-writes the information back to the primary drive. Redundancy is a cost-effective way to provide insurance against a fault or a problem in the primary drive and to improve system throughput in high-traffic situations.

When the VoiceMemo application encounters bad information on a primary disk, the system reads the information from the redundant disk immediately. The failure will be unknown to the system user, and will require no intervention. The system marks the bad sector on the primary disk, and recopies the information from the redundant disk as a background function, without interrupting the operation of the system.

In the event of a catastrophic disk crash, the VoiceMemo application transfers immediately to the redundant disk. When the failed disk is replaced, the system begins the shadow writing process for all new operations. In addition, the system restores the unduplicated information to the new disk as an ongoing background function; full redundancy will be restored within a few hours,

with no downtime, and no impact on multimode system users. On a single-module system, there is a maximum of 15 minutes downtime to activate the new hard drive.

13.3 Shared Resource Fax

Beginning with Series 6, FaxMemo resources may be shared across multiple VoiceMemo ports. Customers do not need to dedicate a FaxMemo resource to a VoiceMemo port. Instead, a FaxMemo resource can be shared by assigning it to multiple VoiceMemo ports. If a call comes into one of the ports on the VoiceMemo line group and the caller requests a FaxMemo resource, the system “switches” the call over to the FaxMemo resource available to that VoiceMemo line group. If none is available, the caller will be prompted that “All fax lines are busy.” To ensure the availability of FaxMemo resources, an administrator may dedicate FaxMemo resources to VoiceMemo ports in a 1:1 ratio. For more information on FaxMemo shared resources, please see Product Note 21.

13.3.1. Shared Resource Fax Configuration Example

As an example, let's say a Series 6 Server is going to be used for voice messaging, paging notification, and fax mail. Voice messaging requires an incoming VoiceMemo port that listens for dial tone, DTMF and line breaks. In this example, we'll assign two line ports to the VoiceMemo inbound line group. Paging notification requires an outgoing port, so we'll assign one port to the paging outbound line group. Fax mail requires an inbound port to receive an incoming fax (when callers send faxes into users' mailboxes). Fax mail also requires an outgoing port for users to download their faxes to fax machines. Because Series 6 has FaxMemo shared resource capability, however, we don't need to assign two separate ports to fax mail. Instead, we can assign one fax resource to the FaxMemo line group. The resource in this line group can be used to perform both incoming and outgoing fax mail functions. How do we do this? By assigning this FaxMemo group to the VoiceMemo inbound line group, and also to the paging outbound line group. It now becomes a fax resource for both incoming functions (accepting fax messages and depositing them in users' mailboxes) and outgoing functions (allowing mailbox owners to download their fax messages to fax machines).

Call Flow for Shared Resource Example (Above):

A call flow that maps to this server configuration would be the following. An outside caller, George, dials a Centigram user's (Mary's) telephone number. Mary is not in her office, so the call is forwarded to voice mail, and George records a message. This function used one port on the VoiceMemo inbound line group. Mary has paging capabilities in her mailbox, so she is paged when this new message arrives. This function uses one port on the paging outbound line group. Mary gets the page, notifying her of a new message, and she dials into her mailbox to retrieve that message. This function takes one port on the VoiceMemo inbound line group.

A few hours later, George dials Mary's fax telephone number to leave her a fax. The call is answered by a port on the VoiceMemo inbound line group. As soon as the port answers the call,

it hears fax CNG tone and knows to "switch" (over the MVIP bus) the call over to the fax resource on the FaxMemo group servicing that VoiceMemo line group. The fax resource hears the CNG tone, sends CED tone (the tone that establishes the connection with the sending fax machine) back, and receives the fax from George and deposits it in Mary's mailbox. Mary is again paged because she has received a new message, and she dials into the system to hear her new message. This uses a port on the VoiceMemo inbound line group. When Mary downloads the fax to a fax machine, this uses the fax resource on the FaxMemo group.

If a second caller calls into the system while Mary is downloading the fax, they will not be able to leave their fax message because the one and only fax resource on the system is busy. They will be played a prompt stating that "all fax lines are busy." Because there is just one resource in the FaxMemo group, it can only service one call at a time.

13.3.2. Hardware Rules in Series 6 FaxMemo

1. Rule #1: One or more fax resources can be assigned to FaxMemo groups.
 - System administrators may assign one or more fax resources (available on the FaxMemo MVIP cards) to a FaxMemo group.
2. Rule #2: Fax resources in a FaxMemo group can be assigned to one or more line groups.
 - Resources in a FaxMemo group can be used by more than one line group. For example, a resource in FaxMemo group 1 can be used by a port in VoiceMemo line group 2 that needs to accept a fax message. At the same time, a second resource in FaxMemo group 1 can be used by a port in VoiceMemo line group 3 that needs to accept a personal cover page.
 - If it is necessary to always guarantee the availability of a fax resource, then the Series 6 server can be configured with an equal number of FaxMemo and VoiceMemo resources. More specifically, the Series 6 server in this example can be configured to have the same number of FaxMemo resources in line group 1 as there are ports in VoiceMemo line groups 1 and 2 combined.
3. Rule #3: Fax resources can service both inbound and outbound ports.
 - A fax resource in a FaxMemo group can be used to receive an incoming fax message (inbound function) and, at a later time, to download a fax from a user's mailbox (outbound function). It is not necessary to assign two separate FaxMemo groups to accomplish both of these functions.
4. Rule #4: Just because a port in a VoiceMemo line group has a FaxMemo resource assigned to it does not mean that it can only perform FaxMemo functions."
 - Even though a port in a VoiceMemo line group may have a FaxMemo resource assigned to it, that VoiceMemo port may perform any VoiceMemo function. For

example, the same VoiceMemo port group that is used for telephone answering or general user access can be used to receive inbound faxes. There is no need to dedicate VoiceMemo line groups to perform FaxMemo-only functions.

5. Rule #5: Because FaxMemo groups can be assigned to one or more VoiceMemo line groups, it may be desirable to create multiple inbound port groups, where only one port group has a FaxMemo group assigned to it.
 - In most FaxMemo installations, it is not required that every line group in the system have a FaxMemo resource assigned to it. The only time a FaxMemo resource is absolutely required on an inbound port group is when outside callers will be sending fax messages. For all other calls, including those that will be retrieving faxes, it is not necessary to access the system on a port group that has a FaxMemo resource.
 - This allows you to size a system where the first, and largest, inbound port group does not have a FaxMemo group assigned to it, and is used for telephone answering, general user access, automated attendant, audiotext, fax publishing, etc. If a mailbox owner has the fax mail FCOS and they access their mailbox from this port group, they can perform all fax capabilities, with the exception of "Making" a fax message, "Retrieving" a fax message ONLINE, and inputting a personal cover page into their mailbox (the three user capabilities that actually require an inbound FaxMemo resource). Because they are on a VoiceMemo line group that does not have a FaxMemo resource assigned to it, the system will not prompt them or give them the capability to perform these functions. They can still retrieve their fax messages by redirecting them to a fax machine or a PC equipped with a fax modem.
 - The second inbound port group can have a FaxMemo group servicing it, and be accessed only by outside callers sending faxes, or by some mailbox owners you want to give the capability to "Make" fax messages or "Retrieve" fax messages online, or to input a personal fax cover page.
 - The last line group is outbound and serviced by a FaxMemo group (this could be the same FaxMemo group that services the second inbound port group). This port group delivers retrieved faxes and performs any other outbound functions such as Paging, Call Placement, and Auto Wake-Up. In this configuration, the call flow for Fax mail would be as follows:
 - a) Outside caller accesses user's mailbox and deposits fax message over inbound line group (second line group) that has the FaxMemo group servicing it.
 - b) Mailbox owner accesses their mailbox over inbound line group (the first line group) that does not have the assigned FaxMemo group, and retrieves fax messages by sending them to their default fax number, by inputting a fax number, or by retrieving all unplayed faxes to their default fax number.
 - c) The system queues up the fax delivery requests on the outbound line group (serviced by the FaxMemo group) to be delivered as soon as there is an available resource.

6. Rule #6: Voice ports that send or receive faxes must have access to a fax resource.

- To perform a FaxMemo function over a VoiceMemo inbound port, that VoiceMemo port must have access to a fax resource. If no resource is available at the time of the request, a prompt will be played, stating that "All fax lines are busy." If a fax resource is not available on an outbound port, then the request will be queued until a fax resource becomes available.

APPENDIX I: Class of Service Descriptions

FCOS Feature Bits by Category

Category 1: Greeting Features

060	Ignore dual tone multiple frequencies (DTMFs) during greeting
062	Hang up immediately after greeting
063	Call mailbox attendant after greeting
064	Call mailbox user extension after greeting
065	Play system time after greeting
161	Conditional greetings
162	General greetings
224	Auto-transfer to task before greeting

Category 2: Login Features

001	Login to mailbox
016	Deny recycling with * key
066	Login during greeting in greet-only mailbox
069	Passcode required for mobile DID
081	Only one correct passcode for login
093	Deny change of passcode in first tutorial
101	Deny login on line group 1
102	Deny login on line group 2
103	Deny login on line group 3
104	Deny login on line group 4
105	Deny login on line group 5
106	Deny login on line group 6
107	Deny login on line group 7
108	Deny login on line group 8
109	Deny login on line group 9
130	Passcode cannot be same as mailbox
132	Bad passcode lockout if over limit
151	Deny 333 access for mobile DID
152	Deny login within tree
156	Deny login after greeting
160	Caller must enter linegroup access code
165	Pound Key (#) login
218	Passcode NOT needed on direct calls
219	Login with 0 using cut-through paging
225	Auto-transfer to task upon login

Category 3: Logout Features

- 003 Return to welcome prompt
- 009 Automatic logout if no unplayed messages
- 170 Transfer to Voice Gateway
- 220 No dial extension, e-mail, or Voice Gateway if unplayed messages

Category 4: Attendant Call Features

- 002 Transfer to mailbox attendant
- 098 Say "Press 0" to caller before beep
- 159 Say "Press 0 to return to receptionist"

Category 5: Outside Caller Features

- 002 Transfer to mailbox attendant
- 004 Outside caller functions
- 005 Play outside caller menu prompts
- 017 Fast line release from outside caller
- 041 Receive messages from outside callers
- 051 Do not switch language for outside callers
- 092 User will be in Dial-by-Name database
- 098 Say "Press 0" to caller before beep
- 111 Deny message receipt on line group 1
- 112 Deny message receipt on line group 2
- 113 Deny message receipt on line group 3
- 114 Deny message receipt on line group 4
- 115 Deny message receipt on line group 5
- 116 Deny message receipt on line group 6
- 117 Deny message receipt on line group 7
- 118 Deny message receipt on line group 8
- 119 Deny message receipt on line group 9
- 137 Caller must enter access code
- 176 Say "Press # for more options" to callers
- 203 Walkaway fax for callers
- 221 Deny caller transfer to e-mail/Voice Gateway

Category 6: Prompts Features

- 051 Do not switch language for outside callers
- 082 Soft play (interrupt) message count
- 083 Soft play (interrupt) most prompts
- 097 Do not say "I will ring <name>" in AR
- 098 Say "Press 0" to caller before beep
- 131 Don't say limits of liability statement
- 133 Don't say: "You may start your message now"
- 136 Don't say: "End of message"
- 138 Don't say: "Message complete"
- 140 Say full date when playing messages
- 146 Don't say "VoiceMemo storage is full"
- 157 Repeat message for answering machine
- 159 Say "Press 0 to return to receptionist"
- 176 Say "Press # for more options" to callers
- 202 Do not play mailbox name or extension number
- 208 Play reorder tone after cut-through paging or greet-only
- 209 Tone Only Pager mailbox interface
- 210 Numeric Display Pager mailbox interface
- 211 Voice Pager mailbox interface
- 242 Say variable passcode prompts for business guest mailboxes
- 247 Don't play any prompt to fax call placement recipient

Category 7: Receive Messages Features

039	Notification tone when new message arrives
040	Receive messages from other users
041	Receive messages from outside callers
042	Receive messages from Telephone Answering Service (TAS) operator
043	Receive message of the day
044	Receive user distribution list messages
045	Receive master distribution list messages
046	Announce receipt count at login
047	Notification prompt when new message arrives
088	Receive urgent messages
111	Deny message receipt on line group 1
112	Deny message receipt on line group 2
113	Deny message receipt on line group 3
114	Deny message receipt on line group 4
115	Deny message receipt on line group 5
116	Deny message receipt on line group 6
117	Deny message receipt on line group 7
118	Deny message receipt on line group 8
119	Deny message receipt on line group 9
127	Deny receipt of messages before tutorial run
173	Receive Cut-through Page notify receipt
175	Receive broadcast greeting
179	Receive broadcast name
185	Receive Wakeup Call notification receipt
190	Receive fax messages
198	Receive fax messages only
199	Auto-receipt for fax send
223	Delay requested receipt for 24 hours

Category 8: Play Messages Features

- 006 Rewind and fast-forward during playback
- 007 Pause in record or play
- 039 Notification tone when new message arrives
- 046 Announce receipt count at login
- 047 Notification prompt when new message arrives
- 048 No auto-timestamp of unplayed messages
- 049 No auto-timestamp of played messages
- 050 Play messages
- 052 Auto-play unplayed messages
- 057 Play saved messages in first in, first out (FIFO) order
- 058 Play unsaved messages in FIFO order
- 059 Play unplayed messages first
- 075 Audit receipt message
- 076 Play urgent messages in FIFO order
- 089 Auto-play all messages (new and saved)
- 144 Skip forward to next message
- 145 Message stays in original queue
- 147 Send receipt after full play
- 153 Don't jump to new message from saved queue
- 204 Message skip, forward and backward
- 215 Don't auto-play first message (w/auto-play)
- 216 Play receipts after urgent messages
- 217 Announce text messages without count
- 255 Delete mailbox without unplayed messages

Category 9: Answer Messages Features

- 029 Answer messages
- 019 Answer and mark urgent
- 030 Answer and request receipt
- 031 Answer and mark confidential
- 038 Attach original message to answer
- 147 Send receipt after full play
- 158 Continue sending message (* key)

Category 10: Keep/Discard Messages Features

- 053 Keep messages
- 054 Auto-keep messages
- 055 Discard messages
- 056 Auto-discard messages
- 145 Message stays in original queue
- 227 Undelete last message with * key

Category 11: Make Messages Features

- 020 Make messages
- 021 Make and request receipt
- 022 Make to multiple destinations
- 023 Make and mark confidential
- 032 Make to user distribution list
- 034 Make to master distribution list
- 061 Wait to record (timeout = # key)
- 087 Make and mark urgent
- 092 User will be in Dial-by-Name database
- 096 Make messages before keep/discard
- 110 Make/Give to telephone number
- 126 Make/Give to mailbox with empty GCOS
- 157 Repeat message for answering machine
- 158 Continue sending message (* key)
- 168 Message wait 1, Pager requeue
- 169 Message wait 2, Pager requeue
- 171 Cut-through paging
- 172 Cut-through paging and messaging
- 188 Append # at the end of Cut-through page
- 191 Make fax messages

Category 12: Give Messages Features

024	Give messages
086	Give receipt message
018	Give and mark urgent
025	Give and request receipt
026	Give to multiple destinations
027	Give and mark confidential
028	Give with comments
033	Give to user distribution list
035	Give to master distribution list
061	Wait to record (timeout = # key)
084	Give receipt message with comments
085	Give receipt message to multiple destinations
110	Make/Give to telephone number
126	Make/Give to mailbox with empty GCOS
157	Repeat message for answering machine
158	Continue sending message (* key)
192	Give fax messages

Category 13: Message Addressing Features

018	Give and mark urgent
019	Answer and mark urgent
021	Make and request receipt
023	Make and mark confidential
025	Give and request receipt
027	Give and mark confidential
030	Answer and request receipt
031	Answer and mark confidential
087	Make and mark urgent
095	Mark message for future delivery

Category 14: User Options

- 070 User options menu
- 015 Change wakeup options
- 071 Record or change mailbox name
- 072 Record or change mailbox greeting
- 073 Enter and change mailbox passcode
- 074 Create or modify user distribution list
- 077 Change pager schedule
- 078 Activate user tutorial
- 093 Deny change of passcode in first tutorial
- 094 Change message delivery options
- 095 Mark message for future delivery
- 124 Change paging phone number
- 125 Clear user passcode
- 127 Deny receipt of messages before tutorial run
- 142 Must run tutorial from own phone (SMIDI)
- 143 Change message delivery phone number
- 148 Change auto-wakeup phone number
- 180 Record personal wakeup message
- 195 Specify fax delivery number
- 196 Change default fax number
- 201 Deny trivial passcode
- 249 Allow transfer to help desk during tutorial

Category 15: User Distribution List Features

- 032 Make to user distribution list
- 033 Give to user distribution list
- 036 Auto-receipt for user distribution list messages
- 044 Receive user distribution list messages
- 074 Create or modify user distribution list
- 134 Broadcast message waiting status
- 222 Disallow nesting of distribution list

Category 16: Master Distribution Lists Features

- 034 Make to master distribution list
- 035 Give to master distribution list
- 045 Receive master distribution list messages

Category 17: Check In/Check Out Features

- 008 Mailbox can be checked in/out
- 090 Check in other mailboxes
- 091 Check out other mailboxes

Category 18: Special Function Mailboxes

- 121 Define Tree mailbox
- 122 Define Broadcast mailbox
- 128 Family Head
- 129 Host mailbox
- 068 Define Rotational mailbox
- 120 Default to first child of tree mailbox
- 123 Announce broadcast mailbox name
- 141 Define Chain mailbox in Receptionist
- 147 Send receipt after full play
- 152 Deny login within tree
- 174 Define Broadcast Greeting mailbox
- 178 Define Broadcast Name mailbox
- 186 Default to last child of tree mailbox
- 187 Receptionist call-transfer tree mailbox
- 189 Rotate on full mailbox
- 229 Play names of list 1 children

Category 19: Message Waiting Light Features

- 079 Set message waiting #1 for urgent messages only
- 080 Set message waiting #2 for urgent messages only
- 134 Broadcast message waiting status
- 182 Use primary/alternate as week/weekend for message waiting indication (MWI) 1
- 183 Use primary/alternate as week/weekend for MWI 2
- 205 Do not use text count for message waiting
- 228 Set message waiting #3 for urgent messages only
- 234 Check message wait status of children

Category 20: Fax Features

- 190 Receive fax messages
- 191 Make fax messages
- 192 Give fax messages
- 193 Deliver fax to default number
- 194 Deliver fax online
- 195 Specify fax delivery number
- 196 Change default fax number
- 197 Fax-on-demand for Greeting Only mailbox
- 198 Receive fax messages only
- 199 Auto-receipt for fax send
- 200 Personal fax cover page
- 203 Walkaway fax for callers
- 206 Discard fax message after delivery
- 207 Fax Verify (sending system not self)
- 230 Deny change of fax cover page options
- 235 Display FROM filed on fax cover page
- 236 Display promotional message on fax cover page
- 237 Automatically deliver fax message to default number
- 238 End-of-session multiple fax delivery
- 239 Retrieve all unplayed faxes through user options
- 240 Receive fax on voice recording timeout
- 247 No fax call placement prompts
- 256 Play abbreviated prompt before greeting

Category 21: Paging and Message Delivery Features

- 077 Change pager schedule
- 124 Change paging phone number
- 168 Message wait 1, Pager requeue
- 169 Message wait 2, Pager requeue
- 171 Cut-through paging (CTP)
- 172 Cut-through paging and messaging
- 173 Receive cut-through page notify receipt
- 181 Paging over message delivery, MWI 1 over MWI 2
- 188 Append # to end of cut-through page number
- 208 Play reorder tone after cut-through-page or greet-only
- 209 Tone Only Pager mailbox interface
- 210 Numeric Display Pager mailbox interface
- 211 Voice Pager mailbox interface
- 212 Send page upon answer, greet-only mailbox
- 213 Edit CTP number with * key if no caller menu
- 219 Login with 0 using cut-through paging

Category 22: E-mail, Text, and "OneCall" Features

- 154 Announce text (e-mail) message count
- 170 Can transfer to Voice Gateway (VG) system
- 184 Append mailbox number to VG transfer
- 205 Do not use text count for message waiting
- 217 Announce text messages without count
- 220 No dial extension, e-mail, or VG if unplayed messages
- 221 Deny caller transfer to e-mail/VG
- 224 Auto-transfer to task before greeting
- 225 Auto-transfer to task upon login
- 226 Auto-transfer to task after unplayed messages

Category 23: Network & Voice Forms

- 135 Define template mailbox (MESA-Forms)
- 139 Template: assume last greet mailbox FCOS
- 149 Login to template through rotational mailbox
- 166 AMIS Analog networking
- 231 Passcode Broadcast mailbox
- 232 Allow receipt of passcode broadcasts
- 241 Suppress broadcast forced receipt

Category 24: OneView

- 250 Allow OneView login
- 251 Allow OneView telephone playback/record
- 252 Allow OneView client to change mailbox ID

Limits Class of Service (LCOS) Parameters

Log-In

- Log-In Sessions Per Period
- Billing Period

Speech Recording

- Name Speech Length
- User Message Length
- Outside Caller Message Length
- Greeting Length
- Network Message Length
- Call Placement Message Length

Distribution List

- Number of Lists Per Mailbox
- Number of Members Per List

Messages

- Number of Messages Per Mailbox
- Number of Messages Per Billing Period

Outdialing

- Maximum Digits Allowed
- Call Placement
- Message Delivery
- Maximum Pages in Billing Period
- Auto Wake-Up
- Paging
- Fax Retrieval

Fax Limits

- Number of Fax Messages Per Mailbox
- Maximum Digits for Fax Message Delivery

Purge Schedules

- Unplayed Voice Message Retention
- Played Voice Message Retention
- Urgent Voice Message Retention
- Voice Receipt Retention
- Page Receipt Retention
- Unplayed Fax Message Retention
- Played Fax Message Retention
- Urgent Fax Message Retention
- Fax Receipt Retention

Paging/Message Delivery

- Number of Retry Attempts for Alternate
- Time Interval for Alternates

Miscellaneous

- Future Delivery
- Maximum Attachments on "Give"
- Maximum Attachments on Network

Prompts

- American English (Mnemonic)
- Canadian French
- Danish
- German
- Japanese
- Korean
- Mandarin
- Portuguese
- Australian English
- New Zealand English
- British English
- Latin American Spanish
- Mexican Spanish
- Argentinean Spanish

Network Class of Service (NCOS) Capabilities

- Access a GCOS across the network
- Make a network message
- Make an urgent network message
- Give a network message
- Give an urgent network message
- Answer a network message
- Answer an urgent network message
- Receive automatic receipts for network messages
- Receive a network message
- Receive an "Urgent" network message
- Limit the number of network message attachments
- Broadcast a change of name and/or greeting across the network
- Make a network fax message
- Give a network fax message
- Answer a network fax message

APPENDIX II: Line Card Exceptions

Timeout Parameters:

- #1 Start record no speech time
This parameter sets the maximum amount of time VoiceMemo waits for speech after issuing the “beep” that prompts a caller or system user to record a message or greeting. If no speech is detected, VoiceMemo terminates the record sequence and issues the prompt “Nothing recorded.”
- #2 Stop record timeout
This parameter specifies the maximum interval of continuous silence allowed during the recording of a message or greeting. Silence intervals that are less than the stop record timeout are interpreted as pauses; once the stop record timeout is exceeded, VoiceMemo terminates recording and plays the prompt “End of message.”
- #9 Ringing timeout
The ringing timeout defines the time period that must elapse after the line card detects ringing before a call is treated as a “Ring/No Answer.”
- #35 Sleep after hang up
After VoiceMemo goes onhook, it ignores a ringing event for the amount of time set by this parameter. This timeout ensures that the system is ready to issue the proper greeting when it answers the next call.
- #38 Centrex time out.
Each Centrex call comes in as a ring on the telephone line, and a data packet on an RS232 connection. Among other items, the data package contains the information necessary for VoiceMemo to answer the call with a user’s personal greeting. If ringing occurs first, and a data package is not received before the Centrex time out expires, VoiceMemo plays the general message center greeting. If the data packet is received first, and no ringing occurs before the Centrex time out takes effect, the system invalidates the data packet and waits for a new call.
- #138 No break time after flash
After performing a switchhook flash, VoiceMemo ignores all line break events for the duration set by this parameter. This prevents a disconnect following a switchhook flash.

#140 No break/ring time on loop

No break/ring time on loop is used only when a line card channel is jumpered for loop current. After a hang up or pulse-out command, VoiceMemo ignores line break and ringing events for the time specified by this parameter. Line exception 35 must be disabled for this line exception to be valid.

#142 Inhibit play time

After a port answers a call, VoiceMemo pauses for the time specified by this line exception before playing the greeting or first prompt. The Inhibit play time is adjusted if callers are not hearing the first part of a greeting, or if callers are waiting too long before the greeting begins.

#180 Play delay after DTMF detect

This parameter specifies the time VoiceMemo waits after detecting DTMF before playing a prompt, greeting, or message. Some telephone systems mute the talk path after a DTMF key is pressed; the Play delay after DTMF detect can be increased to prevent these systems from clipping off the beginning of speech after DTMF.

182 Ringback tone maximum silence

This line exception specifies the maximum silence allowed between ringback tone cycles before a greet command terminates automatically with a speech detect event.

Incoming Signal Detection:

#3 Dial tone detect time

#22 Start dial tone timeout

#136 Minimum dial tone detect power

These three parameters, plus signal duration, set the criteria VoiceMemo uses to determine if a signal it is receiving is a valid dial tone.

#128 Minimum busy half cycle (greet)

#174 Minimum busy detection time

#175 Maximum busy detection time

The line card uses the values set for these line exceptions, collectively, to determine if it is receiving a busy tone. When the greet command is active, a different minimum busy half cycle value (parameter #129) is used.

#172 Minimum reorder detection time

#173 Maximum reorder detection time

The line card uses the values set for these line exceptions, together with the minimum busy half cycle (greet) to determine if it is receiving a reorder tone. When the greet command is active, a different minimum busy half cycle value (parameter #129) is used.

#130 TIE trunk break detect time

When a port is jumpered for E&M interface, an M lead break greater than the time specified by this parameter is considered a disconnect.

#131 Loop break detect time

When a port is jumpered for loop current, if the PBX breaks the loop for an interval greater than the time specified by this parameter, VoiceMemo considers the break a disconnect, and goes onhook.

#132 M-lead debounce time

M-lead state changes must last longer than this time to be considered valid.

#133 Delay before wink

After a valid incoming seizure, the port waits this amount of time before sending the wink start signal.

#134 In-ring on time high

#144 In-ring off time

#148 In-ring on time low

#150 In-ring maximum power

#152 In-ring minimum power

The line card port uses these parameters for incoming ringing detection.

- Incoming ringing bursts must be at least as long as the in-ring on-time low value, and less than the In ring on time high value.
- There must be an interval between ringing bursts that is at least as long as the in-ring off-time value.
- Incoming ringing power must be above the in-ring maximum power threshold to be detected.
- When incoming ringing power falls below the in-ring minimum threshold, ringing detection is cleared.

Output Signaling Adjustments:

#14 Pulse per second

This line exception defines the pulse per second rate for dial pulses VoiceMemo outdials.

#23 Flashhook time

This is the number of hundredths of a second that VoiceMemo remains onhook during flash while transferring a call.

#24 Wink start

Wink start is a type of out-signaling capability that usually is required by the central office for DID applications. Certain PBXs also may require wink start signaling on E&M tie trunk connections. The default for this parameter is disabled.

#154 Pulse out interdigit delay

This is the amount of time a port waits between accepting a pulse output command and starting the pulse output of digits.

#164 DTMF output duration

This is the length, in hundredths of a second, of each DTMF tone VoiceMemo outdials.

#166 DTMF interdigit delay

This is the amount of silence, in hundredths of a second, between each DTMF tone VoiceMemo outdials.

#176 DTMF output level

This sets the amplitude of DTMF tone output.

DTMF Detection:

#6 DTMF detect enabled/disabled

This parameter is used to selectively disable or enable DTMF detection on line card ports. DTMF detection normally is enabled; it may be disabled to prevent callers on certain ports from logging into mailboxes, for example.

#25 Enable DTMF Col 3

This line exception enables fourth column DTMF tones (A, B, C, D). Default is disabled.

#32 DTMF receive debounce time

The DTMF receive debounce time specifies the amount of time a DTMF key must be depressed before it is recognized as a valid VoiceMemo command. This line exception is active except when playing or recording a message.

#33 Record DTMF receive debounce

The Record DTMF receive debounce time stipulates how long a DTMF key must be depressed during the recording of a message for the system to recognize the tone as DTMF. The value of this line exception is set higher than line exception 32, which means the DTMF key must be pressed slightly longer during the recording of messages than at other times. Since higher voices often have components that can be mistaken for DTMF tones, but these components are usually of short duration, this parameter can prevent false DTMF detection.

#34 Play DTMF receive debounce

This parameter determines how long a DTMF key must be depressed during the playing of a message for the system to recognize tone as DTMF input. Like the Record DTMF receive debounce time, the value of this line exception is set higher than line exception 32. This prevents VoiceMemo from mistaking high voice frequencies for DTMF when messages are played.

Greet Command Parameters:

#8 Dead line timeout

Dead line timeout sets the number of seconds VoiceMemo waits for ringing, busy tone, or speech after issuing a greeting. Silence intervals greater than the dead line timeout value are interpreted as a dead line or disconnect.

#128 Minimum busy half cycle (greet)

When the greet command is active, the line card uses the minimum busy half cycle (greet), together with line exceptions 174 (minimum busy detection time) and #175 (maximum busy detection time) to determine if a signal it is receiving is a busy tone. This parameter also is used with parameters 172 (minimum reorder detection time) and 173 (maximum reorder detection time) to detect reorder tone while the greet command is active.

#10 Silence timeout

#11 Speak timeout

#146 Speech detect minimum time

#170 Speech detect minimum power (greet)

The line card uses these parameters, together with a characteristic called absolute steadiness, to detect speech.

- The speech or energy burst received by the line card must have a duration that falls between the values set by parameters #146 and #11, and have at least as much energy as the value of parameter #170.
- The speech or energy burst must be followed by a minimum amount of silence, as specified by parameter #10. (This is how the line card differentiates multiple bursts from a single long burst of energy or speech.)
- If the signal received meets these criteria, the greet software measures the absolute steadiness, or the ratio of minimum energy to maximum energy of the signal, to differentiate between a call progress tone and speech. Call progress tones have steady energy throughout the speech detect interval; speech has extremely variable energy.

#182 Ringback tone maximum silence

This line exception specifies the maximum silence allowed between ringback tone cycles before a greet command terminates automatically with a speech detect event.

Speech and Silence Detection During Recording:

#160 Silence delay

This is the maximum amount of silence, specified in frames, needed to detect a pause.

#161 Minimum miniframes not silent

This is the minimum number of miniframes used to reactivate recording after a pause is detected.

#162 Minimum speech frames

This is the minimum number of consecutive frames of speech (as determined by #163) required to set the recording timeout. The Minimum Speech Frames parameter prevents recording from stopping after it has started.

#163 Minimum miniframes speech

This is the minimum number of miniframes of speech needed to determine that an entire frame contains speech. This parameter also prevents recording from stopping after it has started.

Prompt and Message Output Controls:

#4 Pause compression enable

VoiceMemo line cards normally compress intervals of silence, to eliminate pauses in speech before sending messages to the hard disk for storage. In addition to saving disk storage space, pause compression usually improves the quality of message playback. This feature may be disabled, if necessary.

#13 Enable AGC

Automatic Gain Control (AGC) adjusts weak and strong signals to keep the output level of speech constant. This means callers and system users do not hear wide variations in the loudness and softness of greetings, prompts, and messages played to them.

#178 Record prompt output level

This controls the amplitude of the "beep" that is issued before allowing the recording of a message or greeting. The record prompt also is affected by #156 Record prompt duration, which controls the length of the record prompt signal, and #158 Record prompt frequency, which specifies the frequency, in hertz, of the record prompt beep.

New Line Exceptions-Supported by 5.02B and 5.03B:

#200 Background power lower limit

The default is 10. Background power noise levels below this limit are not recorded.

#214 DTMF detect minimum power ratio

The default is 16. Ratio of noise power just before DTMF to power during DTMF must be above this value before DTMF events are sent to the module while in record mode. This ratio adapts upward during recording if a high signal to noise ratio is found. The line exception value corresponds to internal power detectors, and thus is not directly related to dB.

APPENDIX III: Line Card Interfaces

The following line card interfaces are supported by the platform:

- Loop start—The loop start interface is with 4/8-port loop start line cards.
- Ground start—The ground start interface is provided with 4/8-port ground start line cards.
- DID—The DID/E&M interface is provided with 4/8-port loop DID line cards.
- 2-wire E&M—This interface is provided with DID/E&M line cards. Both E&M Types I & V are supported.
- T1—The platform supports direct digital connections to T1 (North America) and, the T1 interfaces emulate loop-start, ground start, DID, and E&M protocols.
- E1—Direct digital E1 connectivity is supported on the Series 6 platform using SS7 integration protocol. Futures will support ESDI, R1, and R2 protocols.
- A power/configuration card is required when analog DID/E&M or groundstart line interfaces are employed. This card provides -48V to the line interface circuits on these cards. One power/configuration card serves up to four 4/8-port analog line cards.

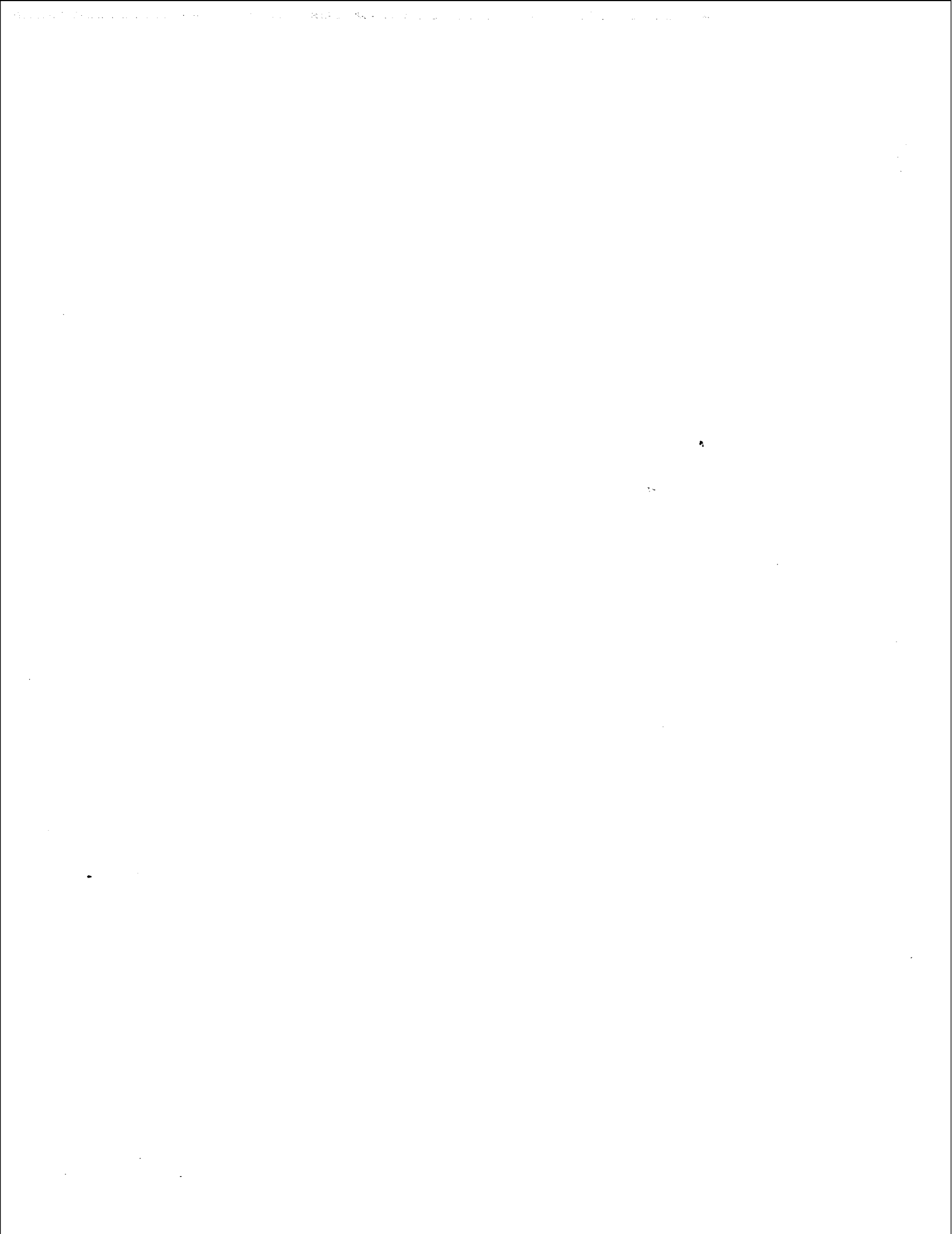

1 VoiceMemo Configuration Main Menu

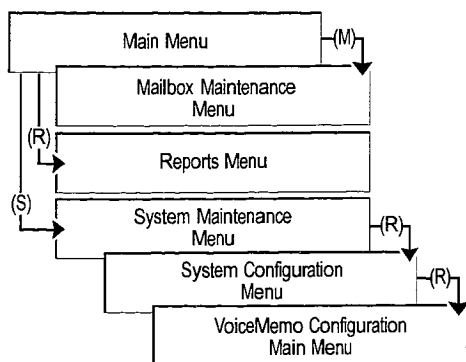

3 Mailboxes

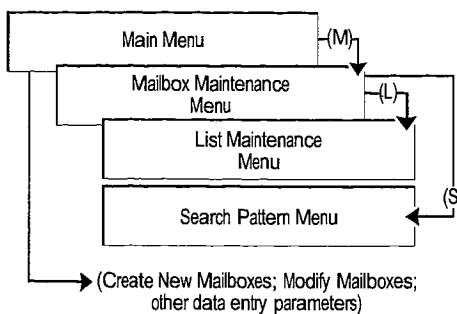

2 VoiceMemo Application

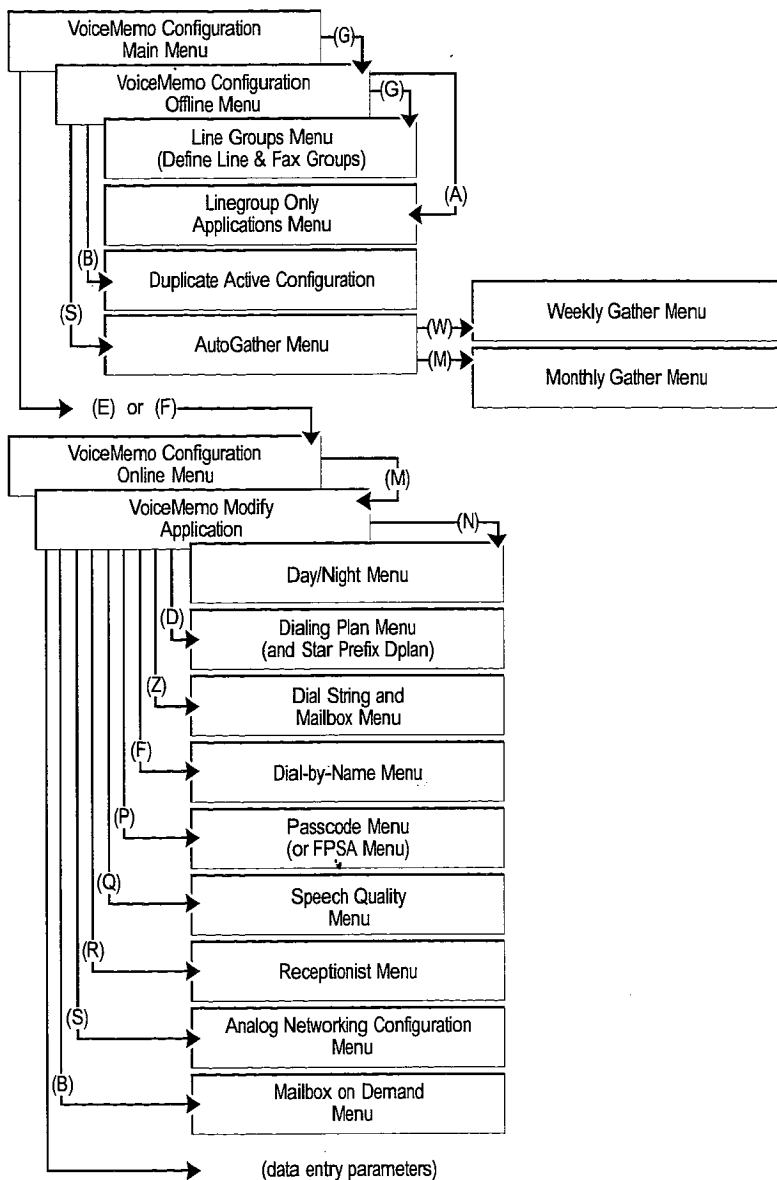

4 DID VoiceMemo Application

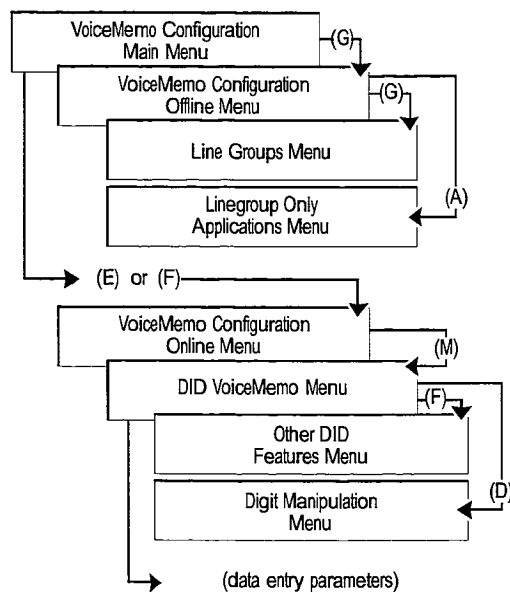

5 Pager Application

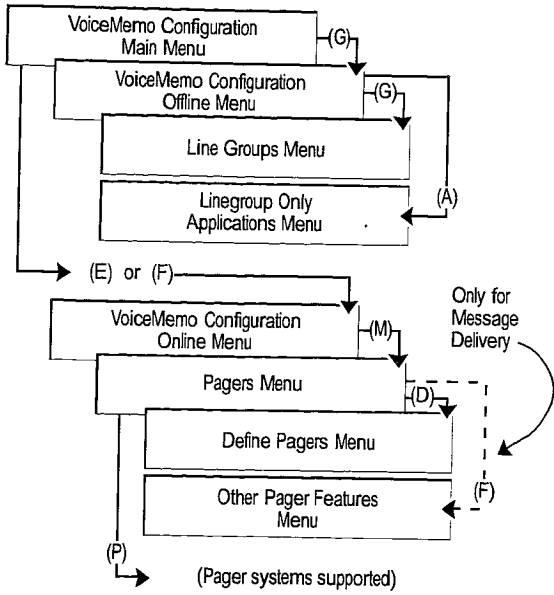

8 Hard Disk Utilities

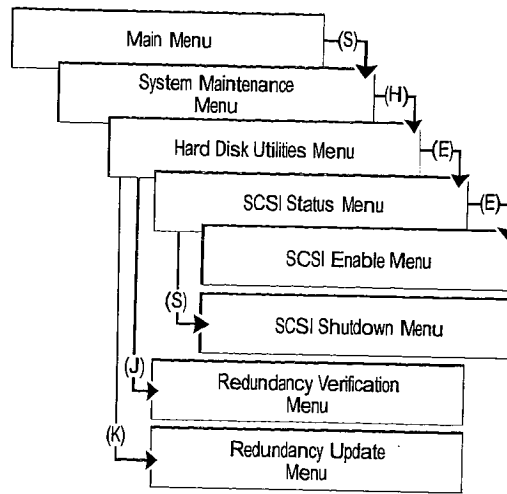

6 RS-232 Message Lights Application

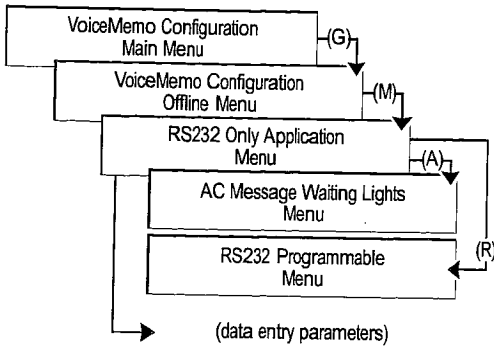

7 DTMF-to-PBX Message Lights Application

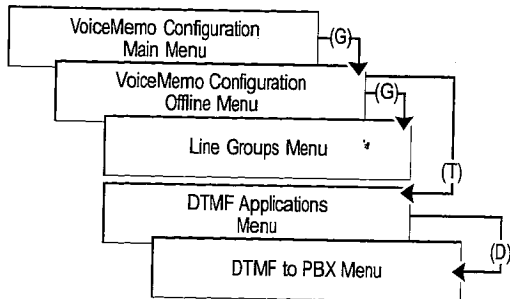

9 Billing & Reports

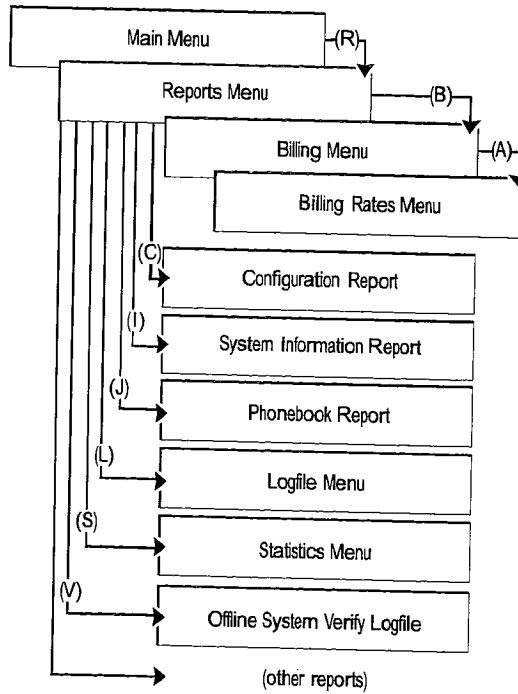

10 Phoneline Exceptions

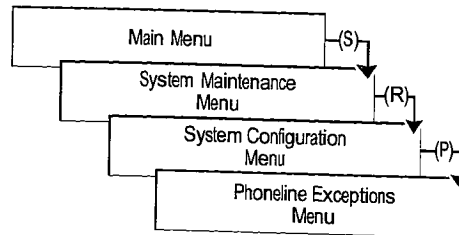

11 FCOS, GCOS, LCOS, RCOS, NCOS and TCOS

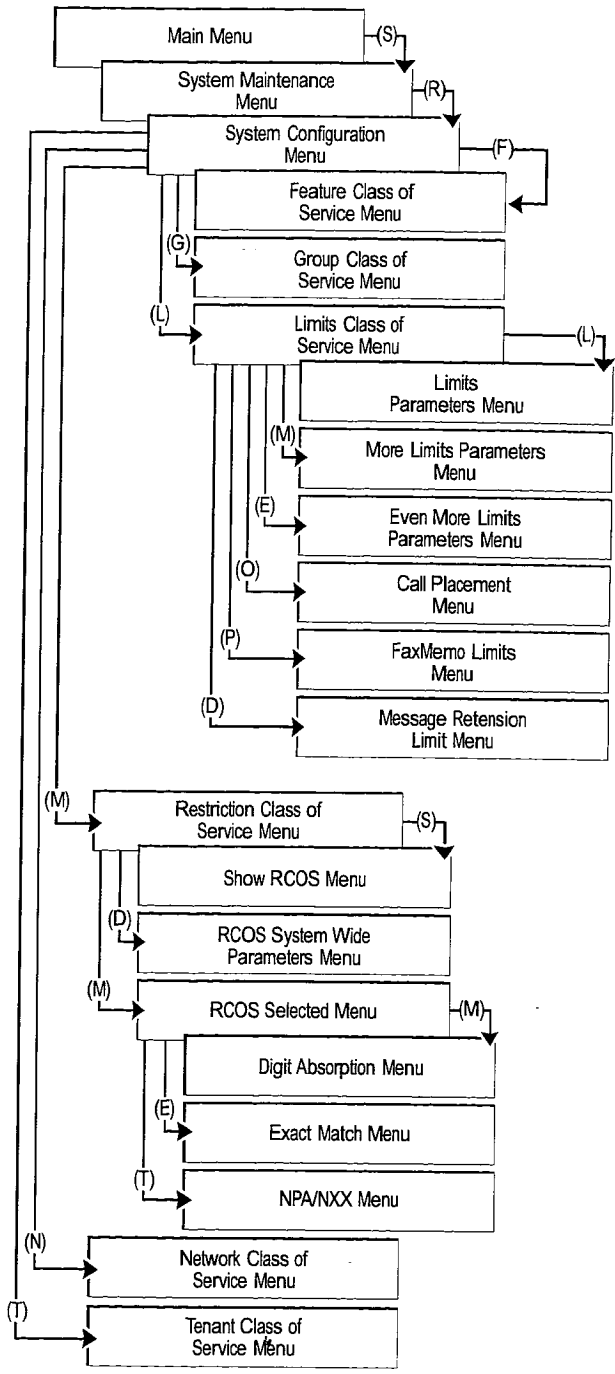

12 System Maintenance

