



NORTHCOM™

PREMIER™ NC-1648
DIGITAL HYBRID KEY SYSTEM

GENERAL DESCRIPTION
INSTALLATION AND
MAINTENANCE MANUAL

NC-1648 DIGITAL HYBRID KEY TELEPHONE SYSTEM

TABLE OF CONTENTS

SECTION 100	INTRODUCTION	
100.10	PURPOSE	1-1
100.20	REGULATORY INFORMATION	1-1
SECTION 200	GENERAL DESCRIPTION	
200.10	TECHNOLOGY	2-1
200.20	CAPACITY	2-1
200.30	SYSTEM COMPONENTS	2-1
200.40	SYSTEM SPECIFICATIONS	2-3
200.41	CABLE SPECIFICATIONS	2-3
200.42	ELECTRICAL SPECIFICATIONS	2-4
200.43	DIALING SPECIFICATIONS	2-5
200.44	SIGNALING SPECIFICATIONS	2-5
200.45	ENVIRONMENTAL SPECIFICATIONS	2-7
200.45	DIMENSIONS AND WEIGHTS	2-7
SECTION 300	FEATURE DESCRIPTIONS	
300.10	KEY TELEPHONE FEATURES	3-1
300.20	SINGLE-LINE FEATURES	3-3
300.30	DSS CONSOLE FEATURES	3-3
SECTION 400	CONFIGURATION	
400.10	KSU CARD SLOT IDENTIFICATION	4-1
400.20	KTU DESCRIPTIONS	4-1
400.21	CENTRAL PROCESSING BOARD (CPB)	4-1
400.22	HIGHWAY INTERCHANGE BOARD (HIB)	4-1
400.23	TONE BOARD (TNB)	4-1
400.24	CONFERENCE BOARD (CNB)	4-2
400.25	CENTRAL OFFICE INTERFACE BOARD (COB)	4-2
400.26	KEY TELEPHONE INTERFACE BOARD (KIB)	4-2
400.27	SINGLE LINE INTERFACE BOARD (SIB)	4-2
400.28	SINGLE LINE CONTROL BOARD (SCB)	4-3
400.29	CO TRANSFER BOARD (CTB)	4-3
400.30	DC/DC CONVERTER	4-3
400.40	EXTERNAL POWER SUPPLY	4-3
400.50	BATTERY CHARGING BOARD (SCB)	4-3
SECTION 500	INSTALLATION	
500.10	SITE PLANNING	5-1
500.20	UNPACKING THE NC-1648 BASIC SYSTEM	5-1
500.30	KSU INSTALLATION	5-1
500.31	KSU MOUNTING	5-1
500.32	KSU CABLING	5-1
500.33	KSU GROUNDING	5-2
500.34	LIGHTNING PROTECTION	5-2
500.40	POWER SUPPLY INSTALLATION	5-2
500.41	POWER SUPPLY LOCATION	5-2
500.42	POWER SUPPLY MOUNTING	5-2
500.43	CORD CONNECTIONS	5-3

TABLE OF CONTENTS — Cont'd

500.50	BATTERY BACKUP INSTALLATION	5-3
500.51	BATTERY CHARGING BOARD INSTALLATION	5-3
500.52	BATTERY INSTALLATION AND CONNECTIONS	5-3
500.60	KTU INSTALLATION	5-5
500.61	KTU HANDLING	5-5
500.62	KTU INSERTION	5-5
500.63	KTU PROGRAMMING	5-5
500.64	DC/DC CONVERTER	5-5
500.70	CO/PBX LINE CONNECTIONS	5-5
500.71	MDF CONNECTIONS	5-5
500.72	EMERGENCY TRANSFER	5-5
500.80	STATION EQUIPMENT INSTALLATION	5-5
500.81	KEY TELEPHONE INSTALLATION	5-5
500.82	DSS INSTALLATION	5-6
500.83	BLF INSTALLATION	5-6
500.84	SINGLE-LINE TELEPHONE INSTALLATION	5-6
500.85	MINI-PRINTER INSTALLATION	5-7
500.86	WALL MOUNT KIT INSTALLATION	5-7
500.87	HEADSET INSTALLATION	5-7
500.90	EXTERNAL APPARATUS CONNECTIONS	5-7
500.91	CONNECTION OF LOUD BELL CONTROL	5-8
500.92	BACKGROUND MUSIC CONNECTIONS	5-8
500.93	MUSIC-ON-HOLD CONNECTIONS	5-8
500.94	EXTERNAL PAGING CONNECTIONS	5-8
500.95	RS-232C TERMINAL CONNECTIONS	5-8
500.96	STATION MESSAGE DETAIL RECORDING	5-9
SECTION 600	INITIALIZATION	
600.10	INSTALLATION CHECK LIST	6-1
600.20	POWER UP SEQUENCE	6-1
SECTION 700	CUSTOMER DATA BASE PROGRAMMING	
700.10	INTRODUCTION	7-1
700.20	GENERAL	7-1
700.30	CUSTOMER DATA BASE PROGRAMMING	7-2
700.31	IMPLEMENTATION	7-2
700.32	SYSTEM PARAMETERS OVERLAY	7-2
700.33	CO LINE OVERLAY	7-3
700.34	STATION OVERLAY	7-3
700.35	SYSTEM SPEED DIAL OVERLAY	7-4
700.36	EXCEPTION TABLE OVERLAY	7-4
700.40	RESIDENT MEMORY	7-4
700.41	DEFAULT DATA BASE AREA	7-4
700.42	DYNAMIC DATA BASE AREA	7-4
700.43	OPERATIONAL DATA BASE AREA	7-5
700.44	NUMBERING PLAN	7-5
700.45	MEMORY BATTERY BACK-UP	7-5
700.46	ON LINE PROGRAMMING	7-5
700.50	PROGRAM MODE ENTRY	7-6
700.51	DSS BUTTON REDEFINITION	7-6

TABLE OF CONTENTS — Cont'd

700.60	PROGRAMMING OVERLAYS	7-6
700.61	OVERLAY MODE ENTRY	7-6
700.62	SYSTEM PARAMETERS DATA BASE ENTRY	7-7
700.63	CO LINE DATA BASE ENTRY	7-8
700.64	STATION LINE DATA BASE ENTRY	7-9
700.65	SYSTEM SPEED DIAL DATA BASE ENTRY	7-9
700.66	EXCEPTION TABLE DATA BASE ENTRY	7-10
700.70	PERMANENT UPDATE PROCEDURES	7-10
700.80	DISPLAY PROCEDURES	7-10
700.81	RS-232 HARDCOPY PRINTOUT	7-10
700.82	DATA BASE DISPLAY WITHOUT A LISTING DEVICE	7-10
700.821	SYSTEM PARAMETER OVERLAY DISPLAY	7-10
700.822	CO LINE OVERLAY DISPLAY	7-11
700.823	STATION OVERLAY DISPLAY	7-11
700.824	SPEED DIAL OVERLAY DISPLAY	7-11
700.825	EXCEPTION TABLE OVERLAY DISPLAY	7-11
SECTION 800	OPERATIONAL TESTS	
800.10	POWER SUPPLY TESTS	8-1
800.20	OPERATIONAL SYSTEM TEST	8-1
800.30	INTERCOM FUNCTIONS TEST	8-5
800.40	CO LINE FUNCTION TEST	8-9
SECTION 900	TROUBLE-SHOOTING	
900.10	GENERAL INFORMATION	9-1
900.11	INTRODUCTION	9-1
900.12	PREVENTIVE MAINTENANCE	9-1
900.13	TEST EQUIPMENT	9-1
900.14	SPARE PARTS	9-1
900.15	FIELD SERVICE ENGINEERING	9-1
900.20	DIAGNOSTIC PROGRAMS AND TESTS	9-1
900.21	DIAGNOSTIC PROGRAMS	9-1
900.22	POWER SUPPLY	9-2
900.23	FUSES	9-2
900.24	INITIALIZATION TEST	9-2
900.25	KEY TELEPHONE TEST	9-2
900.30	TROUBLE-SHOOTING PROCEDURES	9-3
900.31	FAULT CLASSIFICATION	9-3
900.32	SYSTEM FAILURES	9-3
900.321	POWER FAILURES	9-3
900.322	FAILURE INDICATORS	9-3
900.33	STATION/CO LINE FAILURES	9-3
900.34	UNRELATED MULTIPLE FAILURES	9-4
900.35	DSS FAILURES	9-4
900.36	FEATURE OPERATION FAILURES	9-4
900.40	HARDWARE/PCB INFORMATION	9-4
900.41	GENERAL	9-4
900.42	COLOR CODING AND LOCATIONS	9-4
900.43	PCB REMOVAL AND REPLACEMENT GUIDE	9-5
900.44	SUMMARY OF KTU FUNCTIONS, CONTROLS, OPTIONS, AND FAULT CONDITIONS	9-5

100 INTRODUCTION**100.10 PURPOSE**

This manual provides the information necessary to configure, install, operate and maintain the PREMIER NC-1648 Digital Hybrid Key Telephone System.

100.20 REGULATORY INFORMATION (FCC)

The Federal Communications Commission (FCC) has established rules which allow the direct connection of the NC-1648 Digital Hybrid Key Telephone System to the telephone network. Certain actions must be undertaken or understood BEFORE the connection of customer provided equipment is completed.

A) TELCO NOTIFICATION

Before connecting the NC-1648 Digital Hybrid Key Telephone System to the telephone network, the local telephone company must be given advance notice of intention to use privately-owned telephone equipment and provide the following information:

1. The telephone numbers to be connected to the system.
2. The FCC Registration Number which is located on the Key Service Unit. DLP-82V-13254-MF-E
3. The Ringer Equivalence Number which is also located on the Key Service Unit. 0.6A
4. The USOC jack required: RJ21X.

B) INCIDENCE OF HARM

If the telephone company determines that the customer provided equipment is faulty and may be causing harm to the telephone network, it should be disconnected until repair can be effected. If this is not done, the telephone company may temporarily disconnect service.

C) CHANGES IN SERVICE

The telephone company may make changes in its communications facilities or procedures. If these changes should affect the use of the NC-1648 or its capability with the network, the telephone company must give written notice to the user to allow uninterrupted service.

D) MAINTENANCE LIMITATIONS

Maintenance on the NC-1648 Digital Hybrid Key Telephone System is to be performed only by the manufacturer or its authorized agent. The user may not make any changes and/or repairs except as specifically noted in this manual. If unauthorized repairs or alterations are performed, any remaining warranty may be voided.

E) NOTICE OF COMPLIANCE

The NC-1648 Digital Hybrid Key Telephone System complies with rules regarding radiation and radio frequency emission by Class A computing devices. In accordance with FCC Standard 15 (Sub-part J) the following information must be supplied to the end user:

"WARNING:

This equipment generates and uses R.F. energy, and if not installed and used in accordance with the Instructor Manual, may cause interference to Radio Communications.

It has been tested and found to comply with the limits for a Class A computing device, pursuant to Sub-part J of Part 15 of the FCC Rules, which are designed to provide reasonable protection against such interference, when operated in a commercial environment.

Operation of this equipment in a residential area is likely to cause interference, in which case the user, at his own expense, will be required to take whatever measures may be required to correct the interference."

F) HEARING AID COMPATIBILITY

The PREMIER NC-1648 Digital Hybrid Key Telephone System is hearing aid compatible, as defined in Section 68.316 of Part 68 FCC Rules.

30 GENERAL DESCRIPTION**200.10 TECHNOLOGY**

The PREMIER NC-1648 Key Telephone System uses Time Division Multiplexing to perform call switching under control of a Z-80 microprocessor located on the Central Processing Board (CPB). The microprocessor directs switching activity and transmits updated status information to each electronic terminal interfaced with the system. These terminals comprise the Key Telephone Sets (KTS), Direct Station Selectors (DSS) and Busy Lamp Fields (BLF) (Refer to Figure 2.1).

The Key Telephone contains a microprocessor that monitors button activity, controls LED flash rates and notifies the CPB of various telephone states.

The telephone user's voice is transmitted from the instrument to the Key Service Unit (KSU) over standard telephone wiring. The KSU contains printed circuit board assemblies that interface with the telephone wiring and receive the analog voice signal.

The caller's voice signal is sampled at a rate of 8 KHz and is sent to an analog-to-digital converter which generates an equivalent eight-bit binary representation of the original voice signal. This process, Pulse Code Modulation, permits switching with zero loss or distortion.

The digitized voice is transmitted over one of the four separate PCM speech highways provided on the Highway Interchange Board (HIS). Each highway channel has thirty-two (32) time slots for combining thirty-two (32) separate transmissions on one channel facility, operating at a speed of 2.048 MHz. This arrangement ensures continuous, non-blocking operation and eliminates the need for dedicated intercom paths for internal communications. As the call proceeds, the CPB connects system tones as required. A Tone Generator Board (TNB) provides dial, busy, ringback and error tones for distribution on the speech highways.

The caller's voice signal is received at an output location determined by the system switching memory, where it is subsequently decoded and transmitted in its original analog form. Concurrently, the called party's voice is sampled and multiplexed over the same route for transmission to the calling party, allowing both parties to carry on a seemingly uninterrupted, duplex conversation. (Refer to Figure 2.1).

The key system contains 40K bytes of program memory and 20K bytes of data memory. The data or "operating" memory is updated with unique customer feature requirements by interaction with a programming terminal. The DSS attendant console is used as the programming terminal. Selected overlays assist the

programmer to enter the data according to a button depression scheme. The new or existing data can be displayed or validated by monitoring the DSS LED's and integrated buzzer.

The new customer data base is stored in RAM memory that is battery-protected in the event of commercial AC power interruption.

200.20 CAPACITY

The PREMIER NC-1648 Key System is designed to meet the communications requirements of medium to large-size business offices. This modular system is engineered for growth and, utilizing digital technology, provides a flexible assortment of features.

The NC-1648 Key System comprises a wall-mount cabinet (KSU) that contains a DC/DC Converter, modular boards (KTU's) and associated pre-wired connectors. This assembly has a capacity of sixteen (16) CO lines, forty-eight (48) key telephones, two (2) Direct Station Selectors (DSS) and six (6) Busy Lamp Fields (BLF's). A maximum of twenty-four (24) standard single-line (2500 type) telephones can be installed in the system by exchanging key telephone interface boards for single-line interface boards; therefore allowing eight (8) single-line telephones to replace eight (8) key telephones for each board exchanged.

The system is powered by an external power supply, with optional battery back-up provisions for emergency applications.

200.30 SYSTEM COMPONENTS**HARDWARE****NC-1648 BASIC SYSTEM (431531)**

The Key Service Unit (KSU) has card connectors to support a full capacity system of sixteen (16) CO/PBX lines and forty-eight (48) key telephones. The NC-1648 BASIC SYSTEM also includes DC/DC Converter, Central Processing Board, Highway Interchange Board, Tone Generator Board and Conference Board. Two (2) Central Office Boards (Tone) and two (2) Key Interface Boards are included for a basic 8 x 16 line/station interface configuration.

INDIVIDUAL ITEMS**NC-1648 KEY SERVICE UNIT (431533)**

Wall-mount cabinet with all card connectors to support a full 16 x 48 line/station configuration. Includes front cover and Amphenol-type output connectors.

NC-1648 EXTERNAL POWER SUPPLY (433135)

Converts 117 VAC to +24 VDC for source power to the DC/DC converter. Spare connectors are provided for an optional battery charging circuit. Includes 3 ft. AC power cord and 4 ft. DC output cord. The external power supply is UL approved.

NC-1648 DC/DC CONVERTER (433136)

DC/DC converter provides regulated low DC voltage for the integrated circuits utilized in the system. Voltage adjust/test points and LED indicators are provided on the front panel of the modular unit. The 20Hz ringing amplifier for signaling single line telephones is integrated within the DC/DC converter.

COMMON EQUIPMENT CARDS

Four (4) common equipment cards are required to make the NC-1648 operational. These are included in the NC-1648 BASIC SYSTEM.

NC-1648 CPB (435948)

CENTRAL PROCESSING BOARD (CPB) provides the system memory and directs switching activity. Read Only Memory (ROM) contains factory-set operating instructions. Customer data is entered into Random Access Memory (RAM) and is protected by a small lithium battery located on the CPB. Additional RAM-memory is allotted as a "scratch pad" working area for dynamic data. The CPB contains eight (8) LED's as diagnostic aids. Also, a DIP switch assembly is provided for setting various hardware and software interface parameters.

NC-1648 HIB (435955)

HIGHWAY INTERCHANGE BOARD (HIB) provides the system clock and synchronizes the CPB with the system voice and address buses. One hundred and twenty-eight (128) time slots are provided for NON-BLOCKING operation.

NC-1648 TNB (435956)

TONE BOARD (TNB) generates system supervisory tones and allocates these tones to the peripheral circuits. The TNB contains the interface circuits for Music-On-Hold/Background Music, external paging outputs and associated relay controls, and Loud Bell Control. Fuses for DSS 1, DSS 2 and Mini-Printer are located on the TNB.

NC-1648 CNB (435957)

CONFERENCE BOARD (CNB) allows key telephones and external CO line parties to merge into separate three-party conferences, a nine-party conference or any other combination(s) not exceeding nine (9) parties.

EXPANSION CARDS

Expansion cards are provided according to system size and application.

NC-1648 COB-P (435943)

CO INTERFACE BOARD-PULSE (COB-P) interfaces four (4) loop-start CO lines that require dial-pulse signaling. Each COB-P contains program switches for selecting dialing speed (10 or 20 PPS), break-make ratios (60/40, 65/35) and a Normal/Service switch. A monitor LED is provided with each C.O. interface on the card to indicate if that line is ringing, busy or idle. [Maximum four (4) COB cards per system].

NC-1648 COB-T (435942)

CO INTERFACE BOARD-TONE (COB-T) interfaces four (4) CO lines and provides tone sender operation for DTMF applications. Each COB-T provides a switch for placing the card out of service. A monitor LED is provided with each C.O. interface on the card to indicate if that line is ringing, busy or idle. [Maximum four (4) COB cards per system].

NC-1648 KIB (435945)

KEY STATION INTERFACE BOARD (KIB) supports eight (8) NC-1648 Key Telephones. The KIB has four (4) fuses for protecting the key telephone data circuits—one fuse for every two (2) key telephones. A Normal/Service switch is located on each KIB. A monitor LED is provided to indicate when one or more key telephones are in-use. [Maximum six (6) KIB's per system].

NC-1648 SIB (435946)

SINGLE-LINE INTERFACE BOARD (SIB) provides the interface for eight (8) single-line telephones. Each SIB requires a KSU position normally reserved for the KIB-key station interface card. SIB boards are installed in the rightmost slots, in the last three (3) card slot positions. Maximum three (3) SIB's per system, for a total capacity of twenty-four (24) single-line telephones. (Requires the SCB).

NC-1648 CNB (435957)

A second CONFERENCE BOARD (CNB) may be installed in the KSU, effectively expanding the conference capacity of the system to support two 9-party conferences simultaneously.

OPTION CARDS

Operational hardware features are distributed among a few Option cards.

NC-1648 SCB (435944)

SINGLE-LINE CONTROL BOARD (SCB) is plugged into the KSU when DTMF type single line telephones

are required. Maximum one SCB per system, to support up to three (3) SIB cards. The SCB has a Z-80 central processor for allocating system resources to the single line telephones. Four (4) DTMF receivers are located on the card for dialing detection and toll restriction monitoring.

NC-1648 CTB (435947)

CO TRANSFER BOARD (CTB) provides automatic transfer of any six (6) central office lines to pre-designated single-line telephones. Commercial AC power interruption or CPB failure will initiate the transfer process. Maximum one CTB per system.

NC-1648 BCB (435954)

BATTERY CHARGING BOARD (SCB) provides constant voltage charging of two external 12 VDC gel-type batteries. The BCB card is plugged into the NC-1648 External Power Supply (433135). During loss of commercial AC power, full system operation is maintained, without dropping connected calls. Over a prolonged period of power failure, the BCB unit will electrically disconnect the gel-type batteries before over-discharge damage occurs.

STATION APPARATUS

NC-1648 KEY TELEPHONE (475117)

The NC-1648 Key Telephone is a full-modular instrument with sixteen (16) non-locking CO line buttons, twelve (12) function buttons and twelve (12) dial keys for push-button dialing. The telephone contains a microprocessor for local operating functions, such as LED activation and key-button monitoring. An internal speaker provides call announcing, on-hook monitoring and tone ringing. The

set is accented with attractive, non-glare key caps and long-life LED's. Standard with each key telephone is an integrated handsfree speakerphone. A 12 ft. handset cord, 7 ft. mounting cord, user instructions and a spare designation sheet are included.

NC-1648 DSS (475118)

Direct Station Selection functions and Busy Lamp Field display are provided by the DSS, with a maximum of two DSS's per system. In a two-DSS system, the customized programming is done at the first DSS. DSS consoles are equipped with 60 buttons, consisting of 56 LED's to assist the attendant with call processing, and for customer programming. The DSS includes a 7 ft. mounting cord, user instructions and a spare designation sheet.

NC-1648 BLF (475119)

BUSY LAMP FIELD consists of 48 LED's arranged in twelve (12) rows of buttons, four (4) buttons to a row. The BLF contains no function buttons. A maximum of six (6) BLF's may be installed in the system. The BLF includes a 7 ft. mounting cord and a spare designation sheet.

NC-1648 MINI-PRINTER (363006)

MINI-PRINTER provides hard copy print-out (29 character field) of the customer data base. It is equipped with a four-conductor modular cord for quick connection to the modified RS-232C output wired external to the KSU [Includes one (1) roll of metalized paper].

NC-1648 WALL MOUNT KIT (460479)

The WALL MOUNT KIT provides easy mounting for the NC-1648 Key Telephone or DSS.

200.40 SYSTEM SPECIFICATIONS

200.41 CABLE SPECIFICATIONS

Equipment	Cable Type	MAXIMUM DISTANCE (FEET)	
		22 gauge	24 gauge
1648 Key Telephone	Twisted 2-pair	1,800	1,500
DSS/BLF Console	Twisted 3-pair	1,200	1,000
BLF Console	Twisted 3-pair	1,200	1,000
Single Line Telephone	Twisted 1-pair	4,500	3,000
Mini-Printer	Twisted 2-pair	200	150

200.42 ELECTRICAL SPECIFICATIONSPOWER SUPPLY

AC Input	= 117 VAC \pm 10%, 60Hz, Single Phase
Output Voltage	= 24 VDC \pm 5%
Power Consumption	= 240 VA maximum
Battery Charge Power	= 27.6V @ 2A

DC/DC CONVERTER

DC Output Voltages	= 24 VDC \pm 5%
	+ 5 VDC \pm 1%
	- 5 VDC \pm 4%
Ringing Output Voltage	= 50-85V Rms
Ringing Output Frequency	= 20 Hz
Ringing Power Consumption	= 1.2VA

FUSE SPECIFICATIONS

<u>Location</u>	<u>Description</u>	<u>Name</u>	<u>Rating</u>
Power Supply	AC Input	F1	5A 250V
	DC Output	F2	12A 250V
	Battery Charging	F3	12A 125V
DC/DC Converter	+24VDC Output	F1	8A 250V
	+5 VDC Output	F2	5A 250V
TNB	DSS 1	F1	1.25A 250V
	DSS 2	F2	1.25A 250V
	Mini-Printer	F3	0.5A 250V
KIB	Key Station 1/2	F1	0.5A 250V
	Key Station 3/4	F2	0.5A 250V
	Key Station 5/6	F3	0.5A 250V
	Key Station 7/8	F4	0.5A 250V

MISCELLANEOUS SPECIFICATIONS

MOH/BGM Input-Required Output Impedance of Music Source	= Max. 2K ohms
Dry Contact Ratings for External Page Zones 1 & 2 and Loud Bell Control	= 1A @ 24 VDC
External Paging Zones 1 and 2:	
Output Impedance	= 600 ohms @ 0 dBm
Output Power	= 6 mW
Off-Hook Impedance	= 600 ohms
Trunk Type	= Loop Start

ONS

= 10pps, 20pps
 = 60/40, 66/33
 = 3:2, 2:1
 = 10pps — 800 ms.
 20pps — 400 ms.

= ± 1%
 = 5 msec.
 = 70 msec. min.
 = 70 msec. min.

Recial = 24 digits maximum
 = 10 numbers (24 digits) per key telephone.
 = 36 numbers (24 digits) any assigned station.

ATIONS

3-KEY TELEPHONE

	<u>CONDITION</u>	<u>LOCATION</u>
	Steady	C O Line Button
	30 IPM Flashing	C O Line Button
	480 IPM Flutter	C O Line Button
	60 IPM Wink	C O Line Button
ifer	120 IPM Flashing	C O Line Button
	Steady	CONF Button
	Steady	MUTE Button
	Steady	ON/OFF Button
	15 IPM Flashing	MW Button
back	30 IPM flashing	HOLD Button
	30 IPM flashing	CAMP-ON Button

3-DSS/BLF

	<u>CONDITION</u>	<u>LOCATION</u>
	Steady	Station
	Steady	NIGHT Button
	Steady	INT Zone 1-4 Buttons
		EXT Zone 1-2 Buttons
	480 IPM Flutter	Station
	60 IPM Flashing	Station

DURATION (SEC)

Sec ON/4 Sec OFF (R)
 ble Splash every
 Sec (R)
 Sec ON/2 Sec OFF
 Three Bursts)
 ble Splash 1 Sec
 ry 5 Sec (4 Rings)
 ble Splash every
 Sec (R)
 Sec ON/0.2 Sec OFF
 Three Bursts)
 tinuous for 60 sec.
 Sec ON/0.5 Sec OFF (R)
 Sec ON/4 Sec OFF (R)
 Sec Burst (Muted)
 Sec ON/4 Sec OFF (R)
 Sec ON/0.2 Sec OFF
 Times Pause (R)
 Sec ON/0.2 Sec OFF (R)
 Sec ON/0.2 Sec OFF
 Three bursts)
 er 60 Sec.
 er 60 Sec.
 Sec Burst
 ntinuous

Sec Burst
 7 times

DURATION (SEC)

ble Splash in 1 Sec.
 ble Splash in 1 Sec.
 every 5 Sec (R)
 Sec ON/0.2 Sec OFF
 Three Bursts)
 ntinuous for 15 Sec.
 Sec ON/0.5 Sec OFF
 Sec ON/4 Sec OFF (R)
 Sec ON/4 Sec OFF (R)

DND Interception	440 Tone (H)	0.2 Sec ON/0.2 Sec OFF 3 Times-Pause (R)
Error Tone	480 + 620 Tone (H)	0.2 Sec ON/0.2 Sec OFF (R)
Intercom Time-Out	480 + 620 Tone (H)	After 15 Sec.
Interdigit Time-Out	480 + 620 Tone (H)	After 30 Sec.
Hold Confirmation Tone	440 Tone (H)	0.2 Sec ON/0.2 Sec OFF 3 times-intercom dial tone
Originator's Zone		
Page Alert Tone	620 Hz (H)	1.0 Sec Tone
Transfer Tone	440 Tone (H)	Continuous

NOTES: (H) = Handset (S) = Station Speaker (R) = Repeated

200.45 ENVIRONMENTAL SPECIFICATIONS

Operating temperature range	32-104°F (0-40°C)
Humidity	0-90% (non-condensing)

200.46 DIMENSIONS AND WEIGHTS

KEY SERVICE UNIT FULLY LOADED WITH DC/DC CONVERTER

Height	27 3/16"
Width	18"
Depth	11"
Weight	76 lbs.

POWER SUPPLY

Height	11"
Width	12"
Depth	8"
Weight	40 lbs.

DC/DC CONVERTER

Height	12"
Width	3 1/2"
Depth	8 1/4"
Weight	12 lbs.

KEY TELEPHONE STATION

Height	3"
Width	8"
Depth	9"
Weight	3 lbs.

DIRECT STATION SELECTOR

Height	3"
Width	8"
Depth	9"
Weight	3 lbs.

BUSY LAMP FIELD

Height	3"
Width	5"
Depth	9"
Weight	2 lbs.

MINI-PRINTER

Height	3 3/4"
Width	3 1/4"
Depth	8 7/8"
Weight	3 lbs.

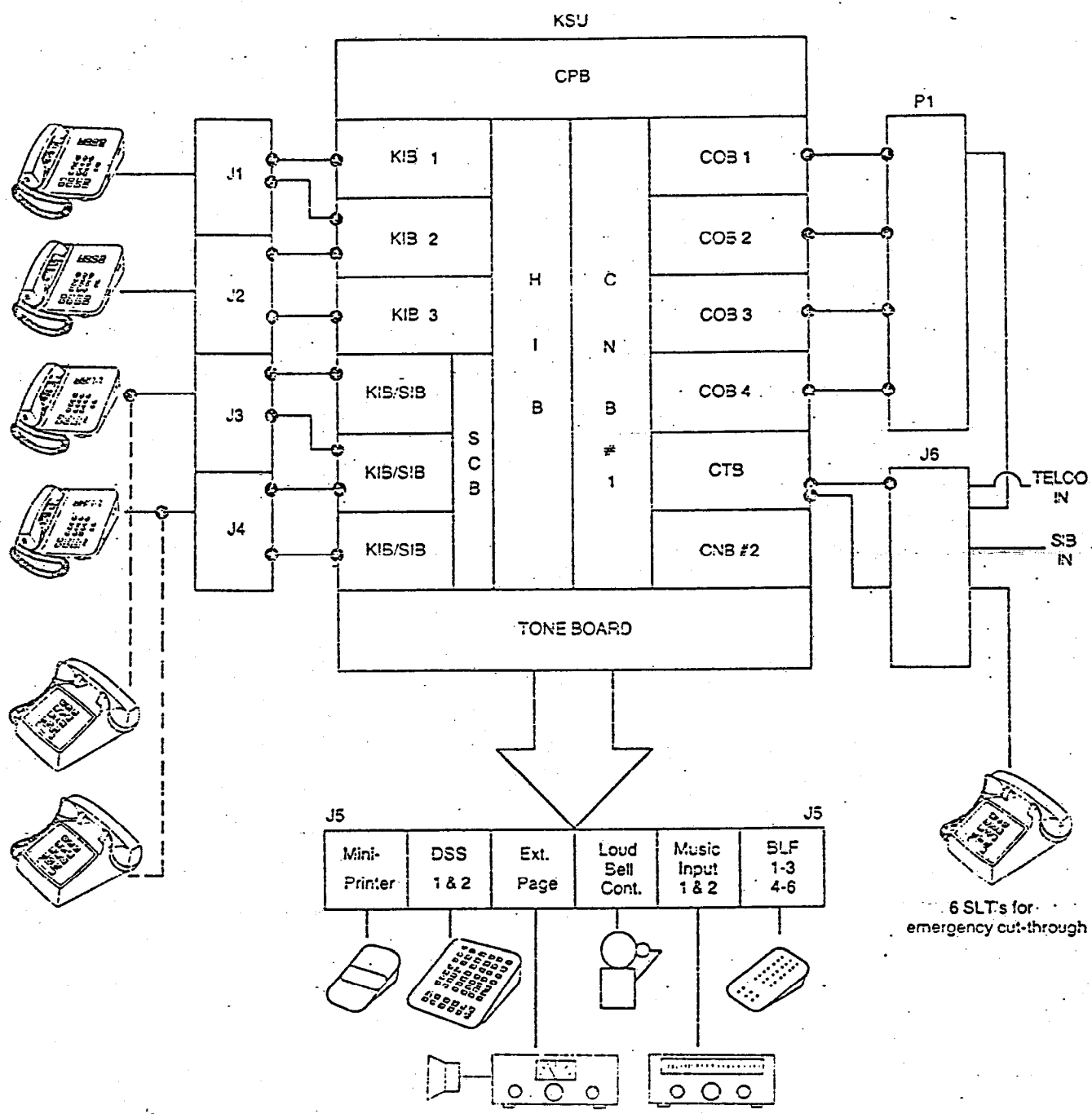

FIGURE 2.1
FUNCTIONAL BLOCK DIAGRAM OF NC-1648 KSU

300 FEATURE DESCRIPTIONS**300.10 KEY TELEPHONE FEATURES
(ALPHABETICAL)****ALL CALL PAGING**

The system allows three (3) forms of All-Call paging; internal, external and system.

AUTOMATIC CO LINE HOLD

An active CO line call is automatically placed on Ex-Hold when many of the feature buttons are pressed.

AUTOMATIC INTERCOM SELECTION

A station user is automatically connected to intercom dial tone when lifting the handset.

BACKGROUND MUSIC

Key telephone users may select either of two channels of background music over the key telephone speakers. [customer provided music source(s) required].

BATTERY BACK-UP (MEMORY)

The system memory is maintained in the event of commercial AC power interruption. The unique customer data base, system speed numbers, station speed numbers and last number dialed are preserved by a lithium battery provided on the CPB.

BATTERY BACK-UP (SYSTEM)

System Battery Back-Up provides full system operation in the event of a power failure, with the use of an optional charging module for external gel-type batteries.

CALL PICK-UP

Intercom calls and transferred lines to unattended key telephones may be retrieved by other telephones in the system. Up to four (4) Pick-Up Zones may be assigned, corresponding with the four (4) Internal Paging Zones.

CALL TRANSFER

Call handling is simplified with the call transfer process. External CO lines may be quickly transferred to idle or busy stations.

CAMP-ON

Busy stations receive a muted alert tone and may have outside calls announced when a Camp-On is answered.

CO LINE GROUPS

Central Office (C.O.) lines may be grouped for multi-customer/department operations. Access and dialing privileges are distributed on a per CO line group/station basis.

CO LINE KEY PRESELECT

An idle CO line may be pre-selected for use five (5) seconds prior to going off-hook.

CO RINGING

Key stations can be programmed to receive CO ringing for any combination of common or restricted central office lines.

CONFERENCE

A key station can set up a conference group of up to nine (9) parties consisting of key stations, single line telephones and external CO lines. At any time, the controlling key station may exit the conference without interrupting the other parties. The controller can terminate the conference arrangement by pressing a button prior to the system Conference Time-Out. An optional second nine-party conference group may be provided.

DIAGNOSTIC START TIME

This feature allows the customer to determine the time of day for automatic on-line system diagnostics to occur.

DIRECT LINE ACCESS

Key telephone stations may have direct access to any or all central office or PABX lines.

DO NOT DISTURB (DND)

DND eliminates incoming CO line ringing, intercom calls and paging announcements at the key station(s) in DND mode. DND feature is allowed or denied on a per station basis.

EMERGENCY/POWER FAILURE TRANSFER

Central office lines are automatically connected to pre-designated stations in the event of AC power/battery failure or CPU failure.

EXCLUSIVE HOLD

CO lines are placed on Exclusive (Private) Hold when the user presses the Hold Button.

EXCLUSIVE HOLD RECALL

CO lines placed on Exclusive Hold and forgotten, are pre-programmed to recall the station that initiated the Hold condition.

EXECUTIVE-SECRETARY TRANSFER

When an Executive station is busy or in the DND mode, intercom calls made to the Executive station are rerouted to the Secretary.

EXTERNAL ZONE NIGHT RINGING

During Night Transfer Ringing Mode, specified incoming CO lines may provide warble ring tone over both external paging zones.

EXTERNAL ZONE PAGING

Two (2) zones of external paging equipment may be accessed independently or jointly by any station user.

FLASH

The Flash Button is used to re-establish dial tone or transfer a PABX call.

INTERCOM CALLING

Intercom communications are enhanced by automatic intercom selection and two-digit dialing.

INTERCOM SIGNALING MODE

There are three (3) intercom signaling modes which are user-selectable at each key telephone, they are:

1. (T) Tone Ringing Mode — The called party hears a warble tone over the internal speaker of the telephone.
2. (P) Paging Mode — The called party hears three (3) bursts of speaker tone followed by a one-way voice page.
3. (H) Handsfree Talkback Mode — The called party hears three (3) bursts of speaker tone followed by a voice announcement. A conversation can take place without lifting the handset or depressing the ON/OFF button.

INTERNAL ZONE PAGING

Key telephones may be arranged into four (4) groups of Internal Paging Zones. Voice announcements occur over integrated speakers located in each key telephone.

LAST NUMBER REDIAL

The system retains the last number dialed at each key telephone, permitting redialing of busy numbers. Lines identified as PBX lines will automatically insert a pause following the dialed trunk access code.

LOUD BELL CONTROL

Provision is made for relay control of an external ringing device (provided by customer) that will be activated whenever a CO incoming ring occurs. Specific lines may be precluded from this feature by a customer programming procedure.

MESSAGE WAITING

Unattended key stations may be notified of missed calls. Up to five (5) messages may be queued against any key telephone in the system.

MUSIC-ON-HOLD

Customers receive music over CO lines when placed on Hold (External music source required).

MUTE KEY

During Handsfree Speakerphone operation, the key telephone microphone can be disabled for situations requiring privacy of transmission or in areas where there are high ambient-noise levels.

ON-HOOK DIALING

Calls may be placed without lifting the handset. While holding for another party, this feature permits easy monitoring until conversation begins.

PBX DIALING

Any CO/PBX line may be programmed to ignore first or second digit dialed. This allows station toll restriction to operate properly with PBX line appearances.

PRIVACY

Automatic privacy is provided on all internal and external calls.

SPEAKERPHONE

With the standard integrated speakerphone, the key telephone user may dial a number and converse without lifting the handset.

STATION MESSAGE DETAIL RECORDING

SMDR is a standard feature that allows the customer to track outgoing calls by CO line, number dialed, time of day, date, station that placed the call, and duration of the call.

STATION SPEED DIALING

A station user may program ten (10) frequently dialed telephone numbers for speed calling from that key telephone.

SYSTEM HOLD

A key telephone user may place a CO line into a common Hold state that allows access from any key telephone in the system.

SYSTEM HOLD RECALL

CO lines placed on System Hold and forgotten, can be programmed to recall the station that initiated the Hold condition.

SYSTEM SPEED DIALING

Telephone numbers that are frequently dialed by several key or single line stations may be programmed into thirty-six (36) System Speed access locations. System Speed Dialing privileges are assigned on a per station basis. System Speed ignores the station's toll restriction assignments.

TIME OF DAY

This feature will allow the time of day to be entered into the system, for diagnostic and SMDR purposes.

TOLL RESTRICTION

Each station in the system is supplied with a "class-of-service" level (via a customer-programming procedure) that defines how that station may utilize outside dialing privileges.

TOLL RESTRICTION OVERRIDE

Special types of outside lines may be programmed to ignore a station's assigned dialing restrictions.

TRANSFER RECALL

Transferred CO lines will automatically recall the initiator if unanswered for a pre-determined period of time.

VOLUME CONTROLS

Each key telephone is equipped with separate controls for Tone and Voice Volume adjustments.

300.20 SINGLE-LINE FEATURES

Standard single-line telephones (DTMF type) can be used with the Premier NC-1648 key System. The followings are features associated with the usage of single-line telephones.

CALL PICK-UP

An intercom call or transferred lines to an unattended station may be answered by a single-line telephone assigned to the same Pick-Up Zone.

CO LINE ACCESS

Single-line telephones have programmed dial access to select any or all seven (7) CO line groups.

CO LINE HOLD

A CO line may be placed on Ex-Hold and later retrieved by dialing a single code.

CO LINE TRANSFER

CO lines may be transferred to and from single-line telephones.

EXTERNAL ZONE PAGING

Two (2) External Paging Zones may be accessed by dialing specific two-digit codes.

INTERCOM CALLING

Single-line telephones may make an intercom call by lifting the handset and dialing a two (2) digit number. An intercom call cannot be transferred or placed on hold.

INTERNAL ZONE PAGING

Four (4) Internal Paging Zones may be accessed by dialing specific two-digit codes.

SYSTEM SPEED DIALING

Single-line telephones, if allowed, can utilize the System Speed Dialing feature.

UNIVERSAL NIGHT ANSWER (UNA)

Single-line telephones may answer designated incoming CO lines when the key system is in the Night Service mode.

300.30 DSS CONSOLE FEATURES

The DSS is used in conjunction with the key telephone. The key telephone retains all standard features and operations. The DSS adds to these features. The DSS contains forty-eight (48) buttons for immediate one-button transfer to any station and twelve (12) function

buttons. A recessed data mode entry button is located on the bottom of the DSS. The followings are features associated with the DSS.

ALL CALL PAGING

All Call Paging may be performed quickly via the DSS with one-button operation. The DSS allows All-Call Internal, External and System Paging, with automatic holding of the announced CO line (System Hold).

ATTENDANT OVERRIDE

The attendant may voice override a busy key or single-line telephone or signal a key telephone in the DND mode.

ATTENDANT RECALL

A held CO call left unattended and unanswered at an extension will recall the attendant with a visual and audible indication.

ATTENDANT SEARCH

The attendant may quickly search for an inside party to complete a CO line Call Transfer.

CALL TRANSFER

Call handling is simplified with the DSS Call Transfer process. External CO lines may be quickly transferred to idle or busy stations.

CUSTOMER DATA BASE PROGRAMMING

The DSS is used to update and display the customer data base memory.

DO NOT DISTURB (DND)

A key telephone in the DND mode will be displayed with a distinctive flash.

INTERCOM CALL

Internal communications are enhanced by automatic intercom selection and one-button DSS dialing.

NIGHT RING TRANSFER

When an unattended DSS attendant console is set in the Night mode, specified incoming CO lines will ring at pre-assigned key telephone locations in the system.

ON LINE PROGRAMMING

Key System features can be changed or updated while the system is operating, with virtually no interference with call processing or connected calls.

RELEASE

Provides the attendant one-button release from the call.

ZONE PAGING

Zone Paging, both internal and external, may be performed via the DSS with one-button operation.

400 CONFIGURATION

400.10 KSU CARD SLOT IDENTIFICATION

The printed circuit boards that are equipped in the KSU are referred to as Key Telephone Units (KTU's). The KSU has dedicated card slot positions that are identified by color-coded adhesive labels on the front surface of the card guides. The abbreviated name of the associated KTU is printed on this label. The KTU's have colored ejector tabs that correspond to the colored adhesive labels for quick identification of the proper card slot position.

The upper shelf of the KSU provides eight (8) KTU card slots designated U1-U8, reading from left to right. The lower or bottom shelf of the KSU provides ten (10) KTU card slots designated L1-L10, reading from left to right (Refer to Figure 4.1).

400.20 KTU DESCRIPTIONS

400.21 CENTRAL PROCESSING BOARD (CPB)
CENTRAL PROCESSING BOARD (CPB), located in card position L-2 provides the system memory and contains a Z-80 microprocessor that directs switching activity. Read Only Memory (ROM) contains factory-set operating instructions. Customer data is entered into Random Access Memory (RAM) and is protected by a lithium battery located on the CPB. Additional RAM memory is allotted as a "scratch pad" working area for dynamic data. The CPB contains eight (8) LED's as diagnostic aids. Also, a DIP switch assembly is provided for setting various system parameters. The CPB is color coded with yellow ejector tabs and is located in KSU card slot L2. [Maximum one (1) CPB per system].

The eight-pin DIP switch assembly is located at the front edge of the CPB. The switch pins are numbered 1 to 8 reading from top to bottom (Refer to Figure 4.2).

FUNCTIONS

- Switch 1 – This switch is the "write memory" switch and should be to the left (OFF) position. The switch is momentarily operated to the right (ON) when the customer data base is updated. The switch is then returned to the left (OFF) to prevent forced loading of default data upon power interruption or system hard restart.
- Switch 2 – The CTS (Clear to Send) Disable switch is operated to the left (OFF) position for normal terminal operation. To use a terminal that does not send CTS signal, operate the switch to the right (ON) position. The NC-1548 mini-printer operates with switch 2 selected to the left (OFF) position.

- Switch 3 – Soft restart to monitor switch. Right (ON) normal SMDR monitor. Left (OFF) will enable soft restart to be printed on monitor.
- Switch 4 – Soft/Hard restart switch. Right (ON) normal soft restart routine followed. Left (OFF) upon detection of a bit error, a hard restart will occur instead of a soft restart.
NOTE: Should be in right (ON) position for normal operation.
- Switch 5 – This switch, when right (ON), enables the SMDR output for tracking of system generated calls. When SMDR is not used, should be in left (OFF) position.
- Switch 6 – Printer output format switch. When to the left (OFF) position, the twenty-nine character mini-printer is supported using two-line abbreviated outputs. When to the right (ON) position, a standard eighty-character receiving device may be connected for SMDR listing or hard copy printout of the Customer Data Base.
- Switch 7 – Unused.
- Switch 8 – Unused.

400.22 HIGHWAY INTERCHANGE BOARD (HIB)

The HIGHWAY INTERCHANGE BOARD (HIB) provides the system PCM clock and synchronization. Four (4) PCM speech highways of 32 time slots each, are multiplexed on this KTU. The total one hundred twenty-eight (128) time slots provide for a non-blocking system operation. The HIB is located in KSU card slot L3 and is color coded with orange ejector tabs. [Maximum one (1) HIB per system].

400.23 TONE BOARD (TNB)

The TONE BOARD (TNB) generates system supervisory tones and allocates these tones to the peripheral circuits. The TNB contains the interface circuits for Music-On-Hold/Background Music, two (2) non-amplified External paging zones with associated relay controls, and Loud Bell Control. Two (2) DSS and six (6) BLF consoles are supported by this KTU (Refer to Figure 4.3).

The TNB has three (3) fuses located along the front edge of the card for easy inspection and removal. These fuses provide protection against polarity reversal or short circuits in the connected wiring to the DSS, BLF or Mini-Printer. The TNB is color coded with brown ejector tabs and is located in KSU card slot L4. [Maximum one (1) TNB per system].

**TABLE 4.1
TNB FUSE DETAILS**

Item	Description	Rating
F1	Data/Power for DSS1, BLF1-3	1.25A/250V
F2	Data/Power for DSS2, BLF4-6	1.25A/250V
F3	Power for Mini-Printer	0.5A/250V

400.24 CONFERENCE BOARD (CNB)

The CONFERENCE BOARD (CNB) allows key telephones and external CO line parties to merge into separate three-party conferences, a nine-party conference or other combinations not exceeding nine (9) parties.

The CNB is equipped with a Normal/Service switch and a busy circuit monitoring LED. The service switch may be used to aid in removal of the board with system power on. The CNB is color coded with black ejector tabs and must be located in KSU card position L5.

A second CNB may be inserted in KSU card position slot L6. This card would expand the system conference capability to allow two (2) separate nine-party conferences to occur simultaneously. [Maximum two (2) CNB's per system]

400.25 CENTRAL OFFICE INTERFACE BOARD (COB)

The NC-1648 Key Telephone System has CO/PBX line interface boards for operation with either DTMF or dial pulse signaling lines. Both boards are color coded with white ejector tabs and may be located in KSU card slots L7-L10 (Refer to Figure 4.4). [Maximum four (4) COB's per system]

A) The CO INTERFACE BOARD — PULSE (COB-P) interfaces four (4) CO lines that require dial-pulse signaling. Each COB-P contains program switches for selecting dialing speed (10 or 20 PPS), break/make ratios (60/40, 66/33) and a Normal/Service switch. A busy state monitor LED is provided with each CO interface circuit on the card to indicate if that line is ringing, busy or idle.

**TABLE 4.2
PROGRAM SWITCH SETTINGS FOR COB-P**

Switch SW2 — OFF	% break/make is 66/33 (2/1)
ON	% break/make is 60/40 (3/2)
Switch SW3 — OFF	10 pps
ON	20 pps

B) The CO INTERFACE BOARD — TONE (COB-T) interfaces four (4) CO lines and provides tone sender operation for DTMF requirements. Each COB-T provides a Normal/Service switch. A busy state monitor LED is provided with each CO interface on the card to indicate if that line is ringing, busy or idle.

400.26 KEY TELEPHONE INTERFACE BOARD (KIB)

The KEY TELEPHONE INTERFACE BOARD supports eight (8) NC-1648 Key Telephone sets. Each KIB has four (4) fuses for protecting the key telephone data/power circuits. Each fuse protects two (2) keysets. A Normal/Service switch is located on each KIB. A busy state monitor LED is provided to indicate when one or more key telephones are in use. When the last in progress call is completed and the monitor LED is extinguished, the KIB may be removed from the system with system power OFF. The service switch may be operated to the Down (Service) position to eliminate idle stations from going off-hook and tying up system resources, keeping the card in a busy state. The KIB is color coded with green ejector tabs and may be located in any or all of KSU card slots U2-U7 (Refer to Figure 4.5). [Maximum six (6) KIB's per system]

**TABLE 4.3
KIB FUSE DETAILS**

Item	Description	Rating
F1	Key Stations 1/2	0.5A/250V
F2	Key Stations 3/4	0.5A/250V
F3	Key Stations 5/6	
F4	Key Stations 7/8	0.5A/250V

400.27 SINGLE LINE INTERFACE BOARD (SIB)

The SINGLE LINE INTERFACE BOARD provides the interface for eight (8) single line telephone circuits. The telephones must be equipped with DTMF dials for access to system features and outside lines. The SIB's are installed in KIB card slot positions U5-U7, beginning with the U5 position. The SIB's may be mixed with KIB's in the U5-U7 positions as long as all KIB's are to the left of any installed SIB. For example, if an SIB is installed in card slot U6, a KIB may be installed in the U5 position, but not in the U7 position. Only KIB's may be installed in the first three (3) KIB card slots U2-U4.

The SIB is equipped with a Normal/Service switch, and a busy state monitor LED to indicate if any single line telephones are off-hook. The SIB is color coded with

green ejector tabs. [Maximum three (3) SIS's per system]

400.28 SINGLE LINE CONTROL BOARD (SCB)

The SINGLE LINE CONTROL BOARD (SCB) is plugged into the KSU when single line telephones are required. The SCB supports up to three (3) SIS cards. The SCB has a Z-80 micro-processor for allocating system resources to the single line telephones. Four (4) DTMF receivers are located on this card for dialing detection and toll restriction monitoring. The 20Hz ringing signal is generated on the SCB.

The SCB is color coded with red ejector tabs and is located in KSU card slot position L1. [Maximum one (1) SCB per system].

400.29 CO TRANSFER BOARD (CTB)

The CO TRANSFER BOARD (CTB) provides automatic transfer of any six (6) central office lines to pre-designated single-line telephones. Commercial AC power interruption or CPU failure will initiate the transfer process. A manual transfer switch is provided for testing purpose.

The CTB is color coded with blue ejector tabs and is located in KSU card slot position U1. [Maximum one (1) CTB per system]

400.30 DC/DC CONVERTER

The DC/DC converter receives the 24 VDC from the power supply and converts it into regulated low DC voltage for switching and memory circuits. The front panel of the DC/DC converter is equipped with an ON/OFF switch, +5 VDC fuse, +24 VDC fuse, voltage adjust/test points and power monitor LED's. The 20Hz generated for ringing single line telephones is amplified within the standard DC/DC converter and is located in KSU card slot position U8 (Refer to Figure 4.6).

400.40 EXTERNAL POWER SUPPLY

The NC-1648 EXTERNAL POWER SUPPLY is rated for 10 Amp, 24VDC continuous operation. The power supply may be either floor or wall mounted. It comes equipped with a UL approved 3 ft. AC power-cord and a 4 ft. DC output cord with plug. An AC input fuse and a DC output fuse are located on the top panel with a neon lamp to monitor AC input voltage. The bottom and front panels are vented for convection cooling that directs heated air

away from the KSU. A mounting bracket comes equipped for wall mounting. The power supply is equipped with a special connector and front panel dummy plugs to allow future installation of an optional battery charging circuit.

400.50 BATTERY CHARGING BOARD

An optional BATTERY CHARGING BOARD (BCB) may be plugged into the special adaptor provided inside the standard NC-1648 External Power Supply. The BCB provides electronic switch-over to an external 24V. gel-type battery assembly during emergencies. The switching would occur when commercial AC power is interrupted; without affecting call processing or connected calls. Depending on the capacity of the external battery package, full system operation will continue until AC power is restored. During extended outages, the batteries would normally be damaged by excessive discharge. However, the BCB will monitor the battery terminal voltage and will automatically disconnect the system load when battery terminal voltage is reduced to 22VDC. At this time, the system would switch to the power failure transfer mode. The BCB is shipped in a kit with fuse, warning tag and adhesive label.

**TABLE 4.4
GEL-TYPE BATTERY
AMP-HOUR REQUIREMENTS**

System Configuration	Amp. Draw	Back-Up Time		
		1 Hour	2 Hours	4 Hours
8 x 16	2A	6.5AH	15AH	20AH
12 x 32	3A	8AH	20AH	28AH
16 x 48	4A	15AH	28AH	40AH

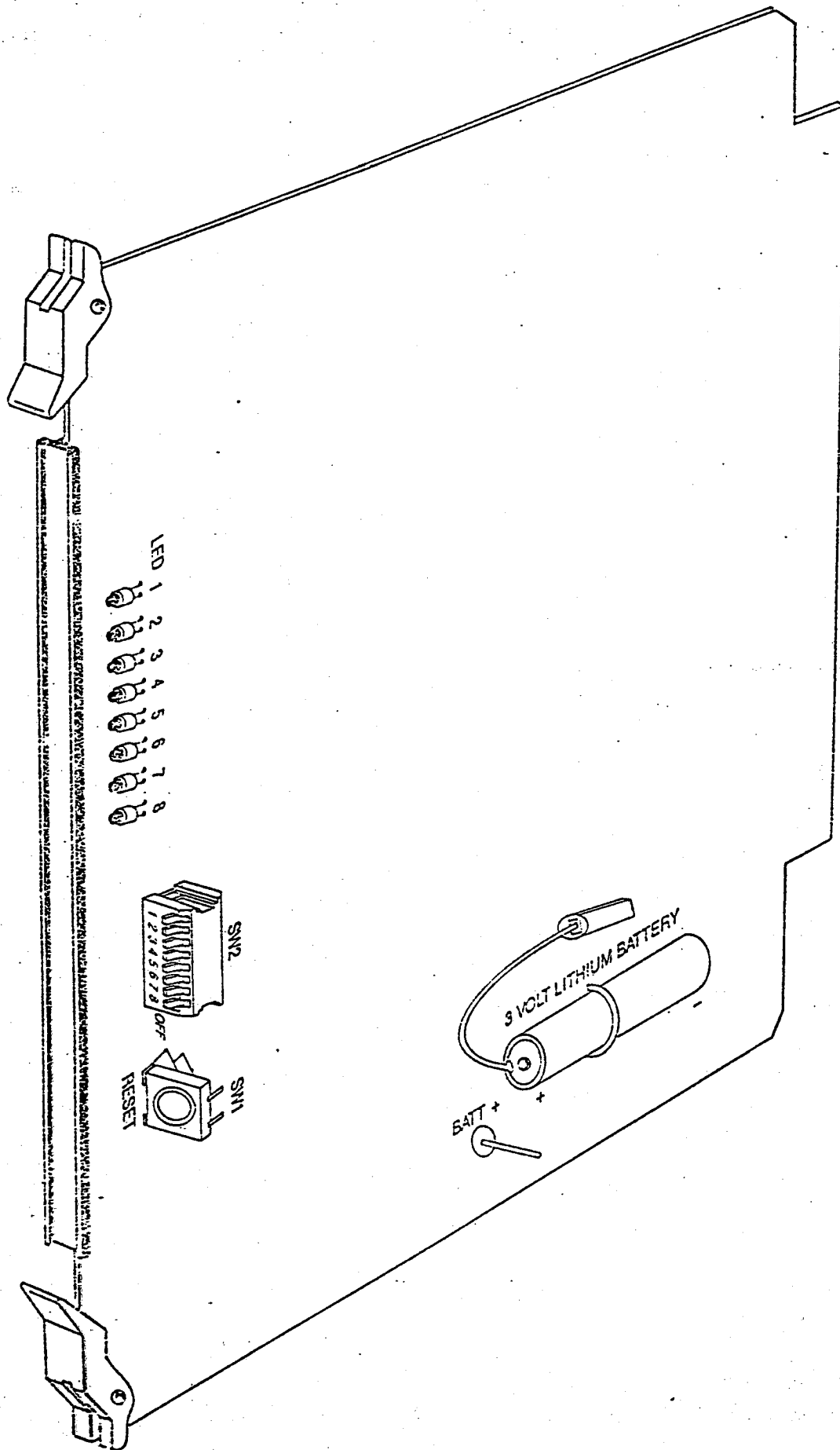

FIGURE 4.2
CENTRAL PROCESSING BOARD (CPB)

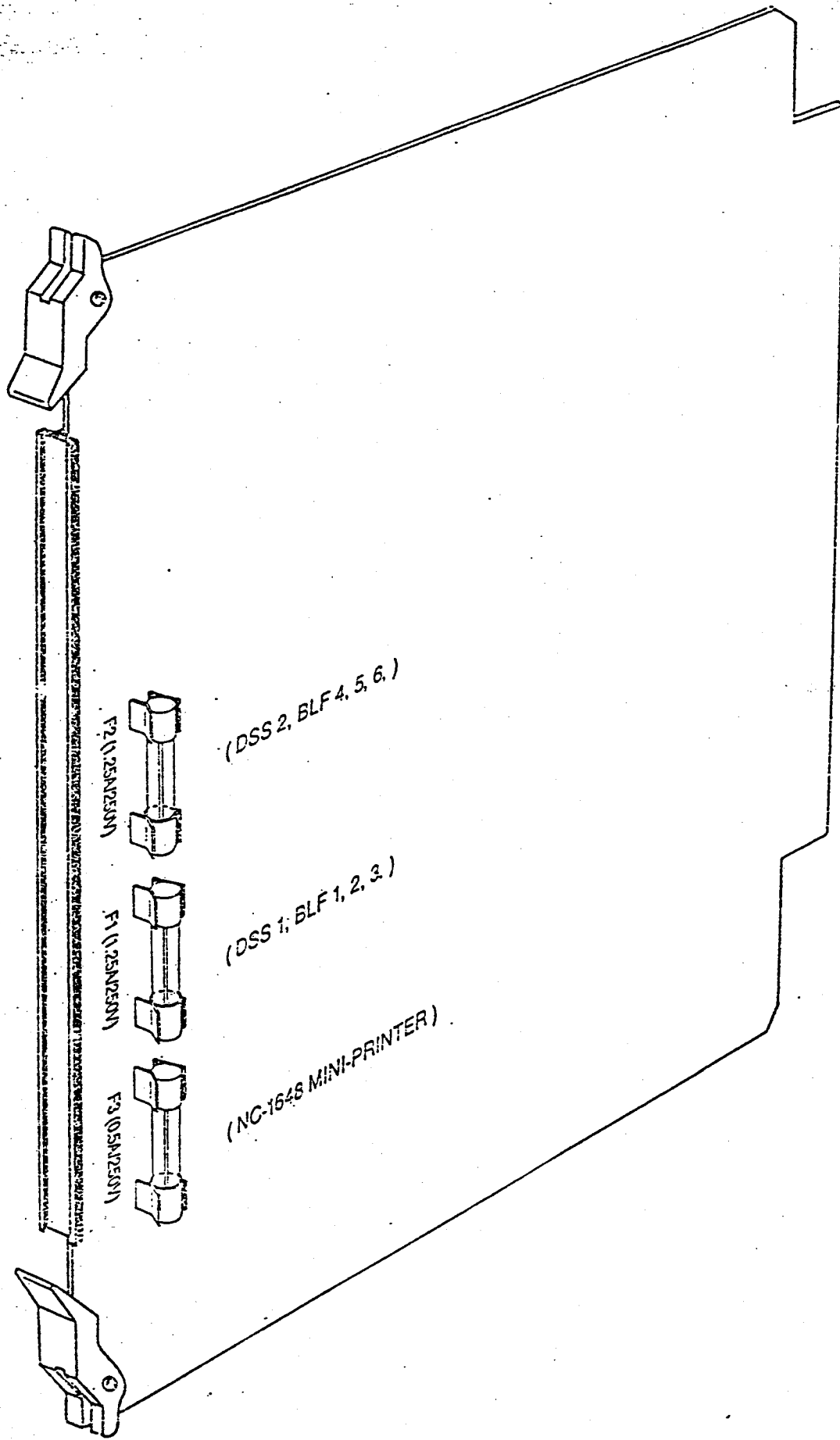

FIGURE 4.3
TONE BOARD

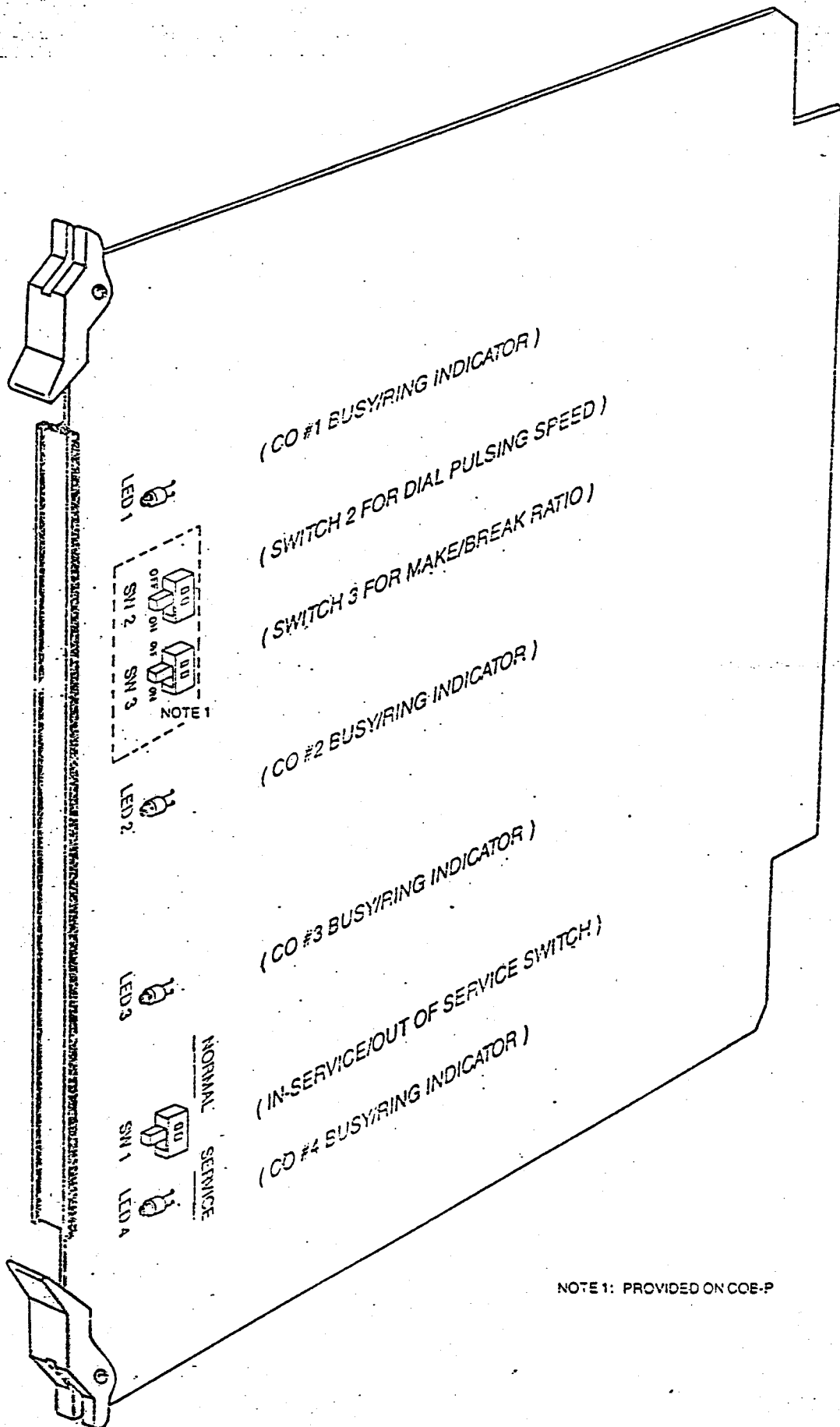

FIGURE 4.4
CENTRAL OFFICE INTERFACE BOARD

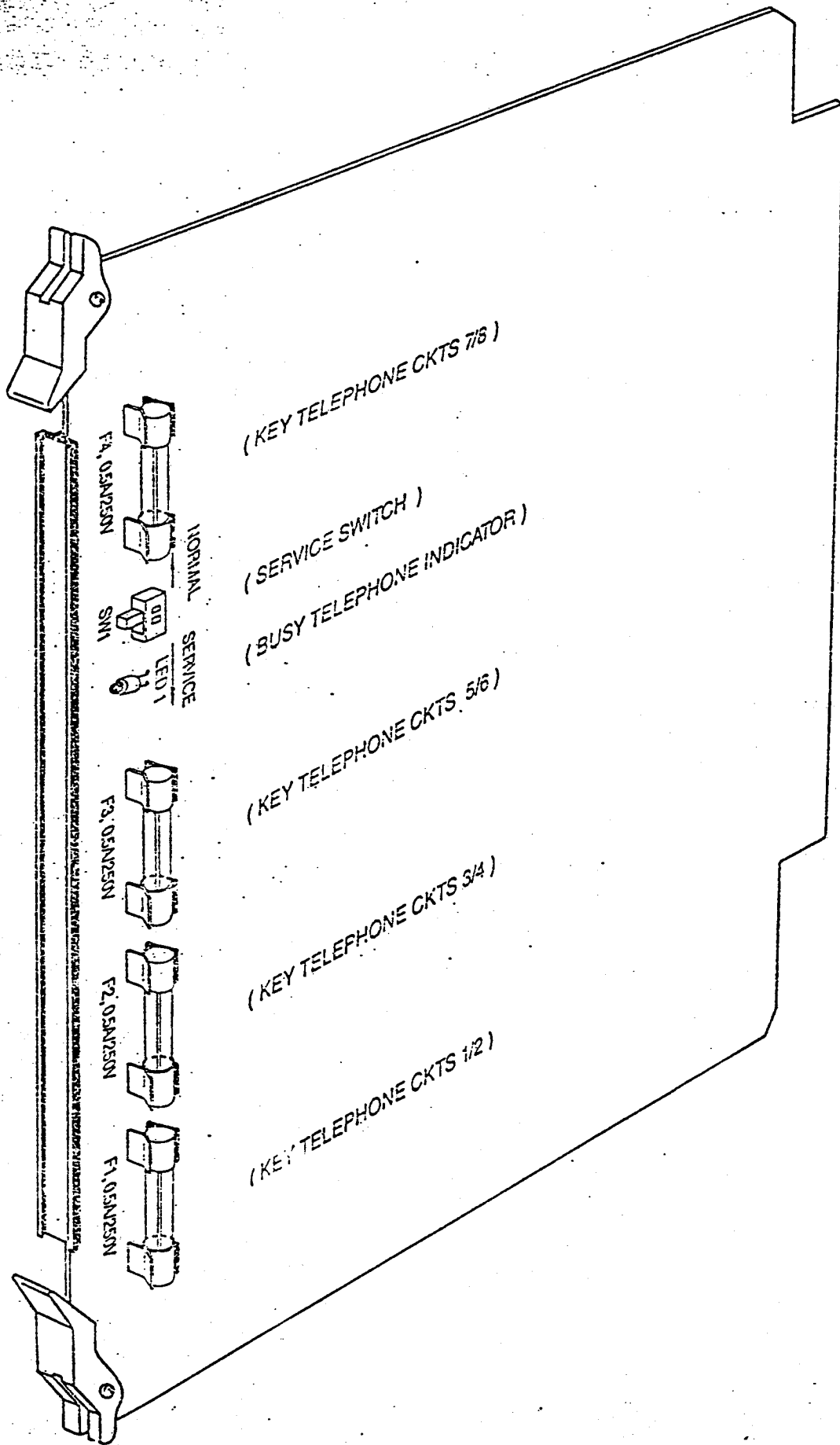

FIGURE 4.5
KEY TELEPHONE INTERFACE BOARD

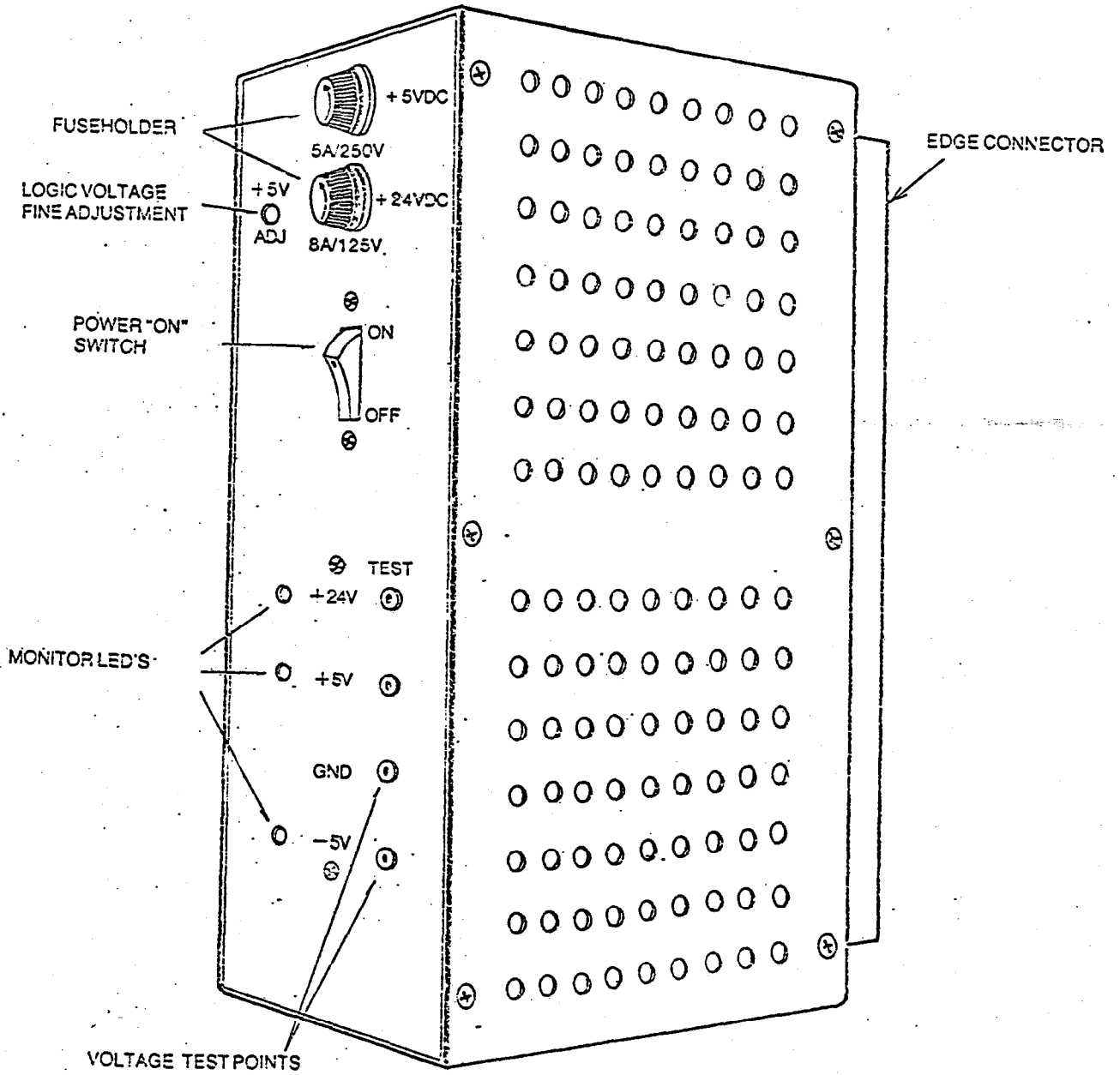

FIGURE 4.6
DC/DC CONVERTER

500 INSTALLATION**500.10 SITE PLANNING**

The NC-1648 Digital Hybrid Key Telephone System, like most electronic office equipment, should not be subjected to harsh environmental conditions. To assure easy servicing and reliable operation, several factors must be considered when planning the system installation. Always consider the following BEFORE installing the KSU and wiring:

- A) The KSU is designed for wall-mounting.
- B) The external power supply may be mounted to a horizontal or vertical surface.
- C) The external power supply operates on 117 VAC, 60Hz, single-phase electricity. A 3-wire (parallel blade with ground) receptacle must be provided on a dedicated, separately fused 15 AMP circuit.
- D) Location of the CO/PBX line terminations. FCC-approved RJ-21X connectors should be located within 25 ft. of the KSU.
- E) Mounting space for punchdown blocks and location of telephone conduits.
- F) A well ventilated area having a temperature range of 32 to 104 degrees Fahrenheit (0° to 40°C), and a humidity range of 0 to 90% (non-condensing).
- G) Accessibility of KSU for servicing and lighting.
- H) Protection from flooding, flammable materials, excessive dust and vibration.
- I) Proximity of radio transmitting equipment, arc-welding devices, copying machines and other electrical equipment that are capable of generating electrical interferences.
- J) Access to a good earth ground such as a metallic COLD water pipe. Inspect the pipe for non-metallic joints.

500.20 UNPACKING THE NC-1648 BASIC SYSTEM

- A) Remove the Key Service Unit from the shipping carton and stand it upright on a level working surface with the cover facing forward. Turn the thumb screws at the top of the cabinet front cover, tilt the cover and lift to remove. Remove all packing material from the inside of the KSU and inspect for shipping damage. Make sure that the printed circuit boards are seated firmly into the card connectors. The KSU is shipped with the DC/DC Converter installed in a separate pocket within the Basic System packing box and should be unpacked at this time.
- B) Inventory the NC-1648 Basic System for the following items:
 - (1) KSU enclosure with cover

- (1) DC/DC Converter
- (1) CPB
- (1) HIB
- (1) TNB
- (1) CNB
- (2) COB-T
- (2) KIB
- (1) Spare Fuse Kit
- (1) NC-1648 Installation Manual
- (1) KSU mounting template
- (1) DSS Overlay Package

500.30 KSU INSTALLATION**500.31 KSU MOUNTING**

- A) The KSU is designed for wall mounting only. The KSU should NOT be mounted directly on a masonry surface. A wooden backboard of sufficient size should be attached to the wall. The KSU, power supply and cable connection blocks should be mounted on the backboard.
- B) Mount the KSU on the back board using four fasteners. The fasteners should be selected carefully so as to be capable of supporting a fully loaded KSU. A mounting template is provided for ease of installation (Refer to Figure 5.1 for mounting hole locations and KSU dimensions).

500.32 KSU CABLING

Seven (7) Amphenol-type connectors are provided on the lower right outside surface of the KSU enclosure (Refer to Figure 5.2). Twenty-five pair telephone cabling must be prepared with mating connectors to extend the KSU interface circuits to the MDF. These cables are then terminated on industry standard 66M1-50 type punchdown connector blocks. The manufacturer recommends using 66M1-50 split blocks with bridging clips to simplify trouble-shooting and quickly isolate faults.

Remove the connector retaining bracket from the KSU and set it aside, for the time being. The left-most connector output is designated P1 and requires a female plug-ended cable for proper attachment. The next six (6) connector outputs are designated J1-J6 reading left to right. Connectors J1-J6 require male plug-ended cables for proper attachment. The actual quantity of required cables is dependent on the configuration of the KSU installation and quantity of telephones connected.

A customer location that does not specify a full compliment of forty-eight stations or does not have power

failure transfer requirements will not require all seven (7) connectorized cables. At the very minimum, the installer should reserve space on the backboard for future system expansions that require installation of the remaining cables and punchdown blocks.

After plugging in the required cables, the retaining bracket should be fastened to the KSU in order to prevent accidental disconnection of the mating connectors.

500.33 KSU GROUNDING

To ensure that the system will operate properly, a good earth ground is recommended. A metallic COLD water pipe will usually provide a reliable ground path. Carefully check that the pipe does not contain insulated joints that could isolate the ground. In the absence of a COLD water pipe, a ground rod or other source may be used. A 10 AWG or larger copper wire should be used between the ground source and the KSU.

The wire should be kept as short as possible, and can be connected to the ground lug provided on the right outside surface of the KSU (Refer to Figure 5.2).

500.34 LIGHTNING PROTECTION

The NC-1648 Key System should have CO lines and OPX stations protected with proper lightning surge arrestors. This will provide protection from damaging surges, induced on environmentally sensitive cabling, by non-direct lightning strikes.

The protection should contain a complement of 3-element gas-discharge tubes to ground high-potential surges, and associated circuits to absorb and filter lower-level surge potentials. This type of lightning protection is available through telephone equipment supply houses. Care should be taken to ensure that such protection devices are installed in accordance with the manufacturer's instructions and to ensure that no more than one set of protectors be installed on central office lines at the installation premises. Improper installation of protection can be a serious safety hazard.

Failure to provide the proper lightning protection will increase maintenance expense and require that larger spare parts inventories be maintained.

500.40 POWER SUPPLY INSTALLATION

500.41 POWER SUPPLY LOCATION

The NC-1648 Power Supply may be wall-mounted or may rest on a clean, dry floor using the rubber feet provided on the underside of the power supply cabinet.

The power supply must be located within three (3) feet of a separately-fused 15 AMP, 117 VAC outlet. A four (4) ft. DC output cord is provided for interconnection of the KSU and power supply.

The power supply may be located directly underneath the KSU, allowing a minimum of six (6) inches clearance between the top of the power supply and the bottom of the KSU cabinet. Another suitable location for the power supply is on the left side of the KSU, reserving the right side for location of MDF connecting blocks. Before mounting the power supply, check clearances to ensure that the AC-input and DC-output cords will extend to the proper locations.

500.42 POWER SUPPLY MOUNTING

Each power supply is shipped with hardware that is used to secure the power supply in a fixed position on a horizontal or vertical surface. A hardware bag with two each type T.C. toggler wall fasteners and two No. 12 hex head sheet metal screws are attached to the power supply. A template is supplied for proper spacing/location of the wall fasteners. A second bag with one AC spare fuse (F1, 5.0 amp, Slo-Blo, 125 VAC), and one DC spare fuse (F2, 12.0 amp, Fast-Blo, 250 VDC) is supplied.

- A) Place the AC spare fuse and the DC spare fuse in the clips provided on the top panel of the power supply.
- B) Spot punch the mounting surface through the template in two places at center-lines located on the template and spaced 8.00" apart (Refer to Figure 5.3).
- C) Enlarge the two spot punched holes to 1/8" diameter with a 1/8" drill.
- D) Drill through mounting surface in the two enlarged holes with a 5/16" drill.
- E) Remove the hardware bag from the power supply carton, and the hardware from the bag.
- F) Fold in the anchor legs of one toggler.
- G) Insert the toggler into the 5/16" diameter hole until the flange on the neck end is flush with the mounting surface. If this is difficult, the toggler may be driven by tapping with a hammer.
- H) Install the No. 12 hex sheet metal screw. The bottom of the screw head should be 3/32" to 1/8" from the mounting surface.
- I) Repeat procedures 5, 6, 7, and 8 for second 5/16" diameter hole.
- J) Hook-up the power supply assembly. The mounting plate which is extended from the top of the power supply has two keyholes spaced 8.00" apart. The

large section of the keyholes will allow the mounting plate to pass over the screw hex head. Slightly lower the power supply so the small section of the keyhole is under the hex head and the power supply weight is supported on the basic screw diameter.

- K) Tighten each screw so that the mounting plate is flush against the mounting surface. Do not over-tighten the screws.

A surge protector should be installed at the AC receptacle. The recommended protector device is a TII Model 428 plug-in power line surge protector. Connect this unit or equivalent type according to the manufacturer's instructions.

500.43 CORD CONNECTIONS

The locking connector is provided on the end of the four (4) ft. 24VDC output cord of the power supply. Plug the twist lock DC output cord into the female connector (DC IN) located on the lower-right outside surface of the KSU cabinet. **DO NOT PLUG IN THE AC CORD AT THIS TIME**

500.50 BATTERY BACKUP INSTALLATION

500.51 BATTERY CHARGING BOARD INSTALLATION (OPTIONAL)

Each kit is shipped with the following:

- Item 1 - 1 Ea. Battery Charging Board
- Item 2 - 1 Ea. Fuse
- Item 3 - 1 Ea. Foto Foil (Model)
- Item 4 - 1 Ea. Warning Tag

Items 2 through 4 are in a battery installation parts bag.

- A) Remove the power plug from the wall outlet and disconnect the power supply from its load.
- B) Remove the battery installation parts bag from the kit and the fuse from the bag. Place the fuse in the clip provided on the top panel of the power supply marked "Battery Protection Fuse."
- C) Remove the cover screws and remove the top cover from the power supply.
- D) Unplug the nylon connector from the connector socket which is mounted on the bracket in the NC-1648 Key System Power Supply. Position the nylon connector and the wiring harness in the "NYLON CONNECTOR DURING INSTALLATION" position (Refer to Figure 5.4).
- E) Bend the hole plug retaining tabs toward the center of the plug. Loosen and remove the three hole plugs from the front panel and discard.

- F) Remove the Battery Charging Board from the packing box and save the BCB for the next step.
- G) Remove the 6-32 screw from the threaded fastener in the plug-in module bracket and retain it for later use. Mount the plug-in module on the side of the bracket with its component side facing outward (Refer to Figures 5.4 and 5.5 for NC-1648 Power Supply). Align the two pins on the plug-in module with two holes on the bracket. The white push-button and the fuse holder should protrude through front panel holes. Snap the plug-in module into position at the support bracket. Align the module brackets threaded fastener (mentioned above) with the hole provided in the front panel. To secure the plug-in module, use the 6-32 screw (mentioned above). The nylon connector (removed per Step D above) should slide fully and lock into the connector socket which is mounted on the plug-in module (See "NYLON CONNECTOR AFTER INSTALLATION" position).

NOTE: Take extra care that the position of the wiring harness is inside the chassis frame and conforms to the illustration after installation as shown in Figure 5.5.

- H) Replace the top cover and replace and tighten the screws to hold it in place.
- I) Make sure the white push-button Battery Override Switch is in the out position (OFF) as illustrated in Figure 5.5.
- J) Remove Foto Foil from the battery installation parts bag. Prepare the surface on the front panel, approximately located as shown in Figure 5.6, for the Foto Foil marked VPBSU-1-REV. All contaminants must be removed from the painted surface with alcohol or mineral spirits. To remove the paper backing (liner) from the foil: Place the label face down on a flat surface. Lift the corner of the liner with a fingernail or "Xacto" knife, being careful not to disturb the adhesive. Remove the liner from the adhesive by pulling the liner back upon itself at a 180° angle. Align the label and press one edge on the front panel with a finger of one hand, then squeeze the remaining unapplied portion using a finger of the second hand with firm strokes.

500.52 BATTERY INSTALLATION AND CONNECTIONS

This installation is to follow installation of BCB kit.

- A) The customer has to supply two 12 volt 40 maximum ampere hour (Gel-type) maintenance-free, lead acid

batteries with top mounted terminal tabs (250 fasten tab).

- B) Batteries are to be placed in a limited access room or cabinet with adequate ventilation to dissipate any battery gases that may be present.
- C) The batteries are to be installed in accordance with Article 480 of the National Electrical Code (NEC) and any other applicable codes.
- D) A battery rack should be used to secure the batteries to prevent tipping or any movement that could cause spilling of battery acid or shorting of terminals. The arrangement should protect against all the hazards such as fire, spark, heat, gas fumes and accidents.
- E) Interconnecting means between the batteries and the power supply shall consist of a length of flexible conduit with appropriate fittings or a flexible cord type SJ/SO minimum complying with the National Electrical Code. Also, the cable should be located, routed and clamped (strain relief) in such a way as to prevent the batteries from moving, should the cables be moved.
- F) A 12 Amp-32V minimum fuse, or a 12 Amp DC instantaneous tripping circuit breaker shall be installed, located at the batteries, in line with the battery negative lead, to protect the batteries from damage, in the event of a short or damage to the battery cable.
- G) Basically, the parts requirements for the battery installation are as follows:
 - a) Two each 12 volt batteries
 - b) Battery rack and separator
 - c) A single wire cable assembly with "faston" lugs
 - d) A two wire cable assembly with ring or hooked spade lugs-"faston" lugs.
 - e) A cable clamp (strain relief)
 - f) A battery fuse or circuit breaker
 - g) An NC-1648 External Power Supply with Battery

TABLE 5.1
CONNECTION SPECIFICATIONS

DC INPUT FRONT PANEL TERMINAL BOARD MARKED "24 V BATTERY + & -" TERMINALS			
TERMINAL CAPACITY	TYPE	MAX. LOOP LENGTH	RECOMMENDED WIRE SIZE
10 to 16 Ga.	SCREW	20 Ft.	14 Ga.
		30 Ft.	12 Ga.
		50 Ft.	10 Ga.

Charging Board

- H) Refer to Figure 5.7 "Typical System and Interconnecting Layout" and Figure 5.8 "Typical Battery Post Hardware Illustration." Remove "Battery Protection" fuse from the fuseholder located on the VPBBU-1 printed circuit card and retain it for later use.
- I) See Table 5.1 for wiring considerations.

NOTES: 1) DC input wire size sufficient to restrict voltage drop to one-half volt or less at rated input current between the battery and the power supply. The loop length is the sum of the lengths of the negative and positive leads.

2) All wire sizes meet those recommended by the National Electrical Code and/or local regulations.

3) The power supply and the battery are to be located in a limited access area.

4) Power supply should be mounted so the ventilation openings are not blocked.

- J) WARNING: Do not make connections with the power applied to the power supply.
- K) WARNING: Only trained service personnel may service the Model PBBU and the power supply.
- L) With a two wire cable, connect in series two 12V batteries to the front panel terminal block of the power supply marked with "24V battery," "+", and "-". The "+" terminal on the block would connect to the "+" terminal on the first battery. The "-" terminal on the block would connect to a fuse or circuit breaker "LOAD" (*) terminal. A single wire is used to connect the remaining terminal of the fuse or the "LINE" terminal of the breaker to the "-" terminal of the second battery. A single wire is used to connect the "-" terminal of the first battery to the "+" terminal of the second battery.

CAUTION

* Circuit Breaker must be "open" prior to connecting to the battery terminals.

- M) When connecting a cable terminal to the top mount battery tab, use the following procedure: Align the battery tab with the fasten receptacle on the cable and push straight on. Repeat procedure for each side battery tab.
- N) Connect the load to the power supply.
- O) Replace "Battery Protection" fuse into the fuseholder

located on the VPBBU-1 printed circuit card.

- P) Connect the power plug to the wall outlet. "Close" circuit breaker.
- Q) The NC-1648 external power supply with battery backup may now be operated.

500.60 KTU INSTALLATION

500.61 KTU HANDLING

The KTU's contain static sensitive components that will require a few simple handling precautions to avoid damage:

- A) Keep all PCB's in their protective anti-static bags until they are installed in the Key Service Unit. All PCB's not in the protective bags should be handled by the card edges only.
- B) (Always use a grounded wrist strap when handling the KTU's). This will minimize the possibility of static damage.
- C) Never lay an unprotected card on a carpeted surface.

500.62 KTU INSERTION

- A) The system power must be turned OFF before replacing any KTU's. The Expansion cards (KIB, COB, SIB) should be installed or removed by switching the card into the "Service" mode.
- B) When inserting a card into the Key Service Unit, take care to ensure that the card edges are aligned with KSU card guides and that the component side of the card faces to the right. Note that the card ejector tabs are color coded to match the designations on the KSU. Ensure that the KTU's shipped with the Basic System are securely seated in their respective card connectors. Press firmly on the card ejector tabs.
- C) Insert any remaining expansion KTU's into their respective card slot locations.

500.63 KTU PROGRAMMING

- A) The KIB, SIB, CNB, COB-P and COB-T cards provide a service switch at the front of each KTU. The switch should be operated to the up (Normal) position.
- B) The CPB has a DIP switch assembly for programming various system functions. Ensure that the switches are positioned according to the functions described in Section 400.
- C) The COB-P, if equipped, should be switch programmed for proper dialing speed (PPS) and break/make dialing ratio.

500.64 DC/DC CONVERTER

Locate and unpack the DC/DC CONVERTER in the NC-1648 Basic System packing box. Insert the unit into the KSU, in card slot position U8. Secure with the locking tab located at the bottom left side of the DC/DC converter.

500.70 CO/PBX LINE CONNECTIONS

500.71 MDF CONNECTIONS

An FCC approved RJ21X connector should be supplied by the telco as the demarc facility. The RJ21X is to be located within twenty-five feet of the KSU.

All CO/PBX line connections are made on the P1 cable. The order of connection of the CO/PBX lines at the P1 connector, determines the order of line button appearance on the key telephones (Refer to Figure 5.9).

If power failure emergency telephones are required, the switched CO/PBX lines should be terminated on the J6 connector before wiring is completed on the P1 connector (See Section 500.72). The CTB card must be equipped in KSU card slot U1 if the emergency transfer option is required.

A COB-T or COB-P KTU must be installed in the associated KSU card slot's L7-L10 in order for the CO/PBX line interface connections to be established.

500.72 EMERGENCY TRANSFER

In the event of a commercial AC power interruption or if a CPU failure occurs, designated CO/PBX lines will automatically transfer to single line telephones for emergency communications. These SLT's should be equipped with ringers. They can be DTMF type instruments that are configured with the NC-1648 Key Telephone System, or special Rotary/DTMF type instruments may be set aside for emergency use only.

Twenty-five pair cabling is plug-connected to the J-6 connector on the KSU. The cabling should be terminated on a separate 66M1-50 block. Wire designations are illustrated in Figure 5.10.

Six (6) CO/PBX line transfer circuits are provided on the CTE KTU which is plugged into the KSU card slot U1. Any equipped CO/PBX line may be selected to transfer to the required SLT according to the installer wiring method utilized. Figure 5.11 shows typical connection arrangements.

500.80 STATION EQUIPMENT INSTALLATION

500.81 KEY TELEPHONE INSTALLATION

A maximum of forty-eight (48) Key Telephones may

be installed with the NC-1648 Key System. The key telephones are interfaced with Key Station Interface Boards (KIB's) that have eight (8) circuits per board. The KIB's are installed in card slots U2-U7. Each key station requires twisted 2-pair home run cabling. One end of the cable is terminated on the associated punchdown connector (J1-J4) at the MDF (Refer to figures 5.12 and 5.13). The other cable end is terminated on a 625-type or equivalent 4-conductor modular jack (See Figure 5.14). The key telephone includes a 7 ft. modular cord for connection to the wall-mounted jack.

The key telephones are assigned two-digit intercom directory numbers in accordance with the locations of the KIB's that have been equipped.

The installer should exercise caution when connecting a key telephone with system power on (Note 1). The first pair of wires is reserved for voice transmission. The second pair of wires supplies power and data. The data/power pair is overload protected by a Station Fuse (F1-F4) located on the associated KIB. Each fuse protects two (2) key telephones.

The NC-1648 Key Telephone may be wall-mounted by simple attachment of a modular Wall Mount Kit (See Section 500.86).

NOTE 1: The manufacturer recommends that the MDF connections be made at the last step and, whenever possible, that system power be turned off during wire termination.

500.82 DSS INSTALLATION

Two (2) DSS Attendant Consoles may be installed with the NC-1648 Key System. The primary DSS is pre-assigned to operate with Station 10 (the first key telephone appearance in the system). This reserved attendant position can be reached by dialing "0" or "10" on a system wide basis. The primary DSS also serves as the programming device for creating and loading the customer data base. The second DSS is pre-assigned to operate with Station 11 and is connected when optional two-attendant operation is desired.

Each DSS is installed with twisted 3-pair home run cable. One end of the cable is terminated on the punchdown connector (J5) at the MDF (Refer to Figure 5.15). The other cable end is terminated on a 625 type or equivalent 6-conductor modular jack. The DSS has a 7 ft. modular cord for connection to the wall-mounted jack.

The DSS uses two twisted pairs for data transmission and one pair for power (Refer to Figure 5.10). Since the KSU supplies power to the DSS, no transformer or

external power device is required at the DSS location. The installer should exercise caution when connecting a DSS with system power ON. The two data pairs and power pair for each DSS are fuse protected on the TONE Board (TNB). If adjacent terminals are shorted or wire polarity is not observed, a blown fuse may result.

The NC-1648 Basic System provides interface circuits necessary to operate two (2) DSS attendant consoles, and does not require any additional hardware.

500.83 BLF INSTALLATION

In addition to two (2) DSS consoles, the NC-1648 Basic System will support up to six (6) Busy Lamp Field (BLF) units. Each BLF contains a microprocessor that retrieves data from the DSS interface at the KSU and uses this data to update the LED display. In essence, the BLF is parallel-connected to the DSS and mirrors the station activity displayed on the DSS button field. However, a DSS console does not have to be equipped for the BLF(s) to function.

The BLF is installed with twisted 3-pair cable on the J5 connector cable. Up to three (3) BLF's may be interfaced from the parallel DSS wiring arrangement designated BLF 1-3 on the J-5 connector block. An additional three (3) BLF's may be accommodated by terminating the additional BLF cables on the remaining punchdown terminals designated BLF 4-6.

Do not connect more than three (3) of the BLF's to either DSS parallel interface (BLF 1-3 or BLF 4-6).

Do not exceed six (6) BLF units total.

The BLF has a 7 ft. modular cord for connection to a 625 type or equivalent 6-conductor modular jack. Refer to Figure 5.16 for typical BLF connections. The BLF is not designed for wall-hanging applications.

500.84 SINGLE LINE TELEPHONE (SLT) INSTALLATION

A maximum of twenty-four (24) single line interface circuits may be equipped in the NC-1648 Key System. The instruments must be equipped with DTMF dials. The serving CO/PBX should accept DTMF tones in order for these telephones to properly interface with outside lines. Dial pulse CO lines (COB-P) will operate with the DTMF type telephones, however, the Central Office must be able to ignore the transmitted DTMF tones from the SLT's that would accompany the outpulses from the COB-P interface.

To interface SLT's, the Single Line Control Board (SCB) is required. Also, one (1) Single Line Interface Board

(SIB) must be installed for every eight (8) SLT's equipped. The SIB's are plugged into the last three (3) vacant KIB card slot positions, equipping the slots from right to left. Ring generation is provided by the SCB and external ringing generators are not required for SLT signaling.

The SLT requires one pair home run cable. The cable is connected to the voice pair (VT/VR) of the desired station appearance at the MDF on punchdown connector cables J3 or J4, which extend the station interface circuits associated with card slot positions U5, U6 and U7 (See Figure 5.17). The other end of the SLT cable is connected to a 625 type or equivalent modular jack. The SLT line cord is then connected to the jack.

500.85 MINI-PRINTER INSTALLATION

The NC-1648 Mini-Printer is a twenty-nine (29) character "metalized" paper printer that is designed to display and record the customer data base information obtained during the program sequence. When the SMDR feature is required, the Mini-Printer may be used to provide a two-line output record of calls with a storage capacity of more than 3300 call records per paper roll.

The Mini-Printer is recommended in addition to the DSS console, when updating the Customer Data Base. The DSS will display all temporary or permanent Customer Data Base information.

The primary DSS is used to enter all Customer Data Base information and will display temporary or permanent data. LED's ON the DSS display the entered data for System Speed Numbers, Toll Restriction Allow/Deny Tables, Recall Timers and certain system parameters in a digit-by-digit polling sequence (See Section 700.82). The Mini-Printer will display and record all Customer Data Base information in a field format that allows easy inspection of the Customer Data Base. The record is very useful for future service activity, if left on-site.

The Mini-Printer has a paper feed button and provides a telephone industry standard 4-conductor cord that will plug into a dedicated RJ-14C connector. The installer may install a 625 type modular jack at the MDF for connecting the Mini-Printer. Optionally, the Mini-Printer may be connected to a dedicated length of two-pair twisted telephone cable at the primary DSS location (within 200 feet of the KSU). In either case, the Mini-Printer is line powered by the KSU and does not require external power (Refer to Figure 5.18).

The Mini-Printer wire connections are provided on the J-5 punchdown connector (Refer to Figure 5.15). The

Mini-Printer operates at a data speed of 1200 baud and requires a 29-character field and CTS. The selection procedures for the data output speed and formatting are described in Sections 700.62 and 400.21 respectively.

500.86 WALL MOUNT KIT INSTALLATION

All connections to the key telephones are fully modular. To wall mount the telephone, it will be necessary to have one NC-1648 WALL MOUNT KIT and one 630-A type modular wall mount jack assembly equipped with two mounting lugs.

- A) Remove the mounting cord from the telephone. This cord will not longer be needed.
- B) Substitute the short modular cord on the wall mount baseplate for the mounting cord removed earlier.
- C) Rotate the plastic number retainer upwards to expose the screw underneath. Remove the screw and slide the cover plate under the number retainer towards the hookswitch.
- D) Replace the cover plate with the handset retainer tab that is mounted in the wall mount base plate, and secure with the screw obtained in step C.
- E) Rotate the plastic number retainer downwards and snap into place.
- F) Align the mounting tab on the outer edges of the wall mount base with the holes on the key telephone base. Snap shut and fasten with screw.
- G) The telephone can now be mounted to the wall by mating the two keyhole slots on the baseplate with the lugs on the modular cover assembly. Check to make sure that the modular connector on the baseplate has a firm connection with the connection on the wall jack (Figure 5.19).

500.87 HEADSET INSTALLATION

This section intentionally left blank.

This section intentionally left blank.

500.90 EXTERNAL APPARATUS CONNECTIONS

500.91 CONNECTION OF LOUD BELL CONTROL
External signaling equipment may be operated with the NC-1648 Key System by connection to the Loud Bell Control (LBC).

The LBC provides dry contact closure that will operate when UNA Programmed CO/PBX lines are ringing. The dry contacts are rated at 1.0A/24VDC. This closure will sequence at a rate of 1 second ON/4 seconds OFF until all designated ringing lines are answered.

Wiring connections are made on the J-5 punchdown connector on the pins marked LBCTL. These connections to the LBC are illustrated in Figure 5.18.

The LBC can be selected to operate as DAY/NIGHT mode or operate only in the NIGHT mode. The desired mode of operation is specified during customer data base programming.

500.92 BACKGROUND MUSIC CONNECTIONS

Background music can be provided to all key telephones in the NC-1648 Key System. Two channels are available, allowing individual selection of the music desired.

Channel One — Background Music is connected to the BGM1-T and BGM1-R terminals on the J-5 punchdown block (Refer to Figure 5.15).

Channel Two — Background music is connected to the BGM2-T and BGM2-R terminals on the J-5 punchdown block. Channel two also serves as the system Music-On-Hold channel (See Section 500.93). The output impedance of the music source should not exceed 2K Ohms.

Figure 5.16 illustrates the connection points for the two (2) channels of background music.

500.93 MUSIC-ON-HOLD CONNECTIONS

An external music source may be connected to the NC-1648 Key System for providing music to outside parties that have been placed on hold. This same music channel may be selected by inside key telephone users as one of two background music channels.

Connections for this option are illustrated in Figure 5.18.

500.94 EXTERNAL PAGING CONNECTIONS

External paging amplifier equipment may be connected to the NC-1648 Key Telephone System for dial access from any telephone in the system. There are two (2) non-amplified External Paging Zones provided with the NC-1648 Basic System. If one of the two external paging zones is accessed, the remaining external zone is restricted.

The output impedance of the paging zones is 600 Ohms at 0dBm. The low level voice signal output is specified at 6 milliwatts. Dry contact control is provided to switch "ON" the external amplifier equipment or to momentarily remove background music, if externally supplied to the paging device.

All connections are made on the J-5 punchdown connector (Refer to Figure 5.15). The voice output from the Key Telephone System is provided on the PG1 — T/R pair for External Zone 1; the PG2 — T/R pair for External Zone 2. The "break" contacts are identified as pair PGX-CTLM and "make" contacts are identified as pair PGX-CTLM. Various connection arrangements are illustrated in Figure 5.20.

500.95 RS-232C CONNECTIONS

Figure 5.21 illustrates the standard pin configuration used with the NC-1648 Key System in connecting display

devices. The NC-1648 Key System is fully compatible with standard RS-232C devices.

An RS-232C type connector is provided on the lower, right side of the KSU exterior for quick connection of an available 80-character printer or other receiving device.

The receive transmission speed of the connected terminal should be set at either 300 Baud or 1200 baud, to match the programmable data output speed of the NC-1648 Key System. The system output speed is set by Customer Data Base programming routine defined in Section 700.32.

The CPB card must be switch programmed to provide both desired 29 or 80 character display field, and the proper Clear-to-Send signals (See Section 400.21).

CAUTION

Terminal devices must not be connected to the RS-232C plug and the mini-printed connector output at the same time.

500.96 STATION MESSAGE DETAIL RECORDING

The SMDR feature provides detailed ASCII records to the standard NC-1648 RS-232C port of all outgoing CO line activity exceeding a 30-second call duration. This feature is enabled or disabled by hardware switch selection on the CPB (Refer to Section 400.21 for proper switch setting).

If the SMDR feature is enabled, information acquisition begins at call start time and terminates at call completion. At this point, the call duration is calculated. If the 30-second call duration criteria is met, the acquired information is queued for output format processing.

The SMDR output records contain the following:

1. A 2 digit station call originator field
2. A 2 digit CO Line accessed field
3. A 24 digit collected dial digit field
4. A 5 digit call duration field
5. An 8 digit time of day call origination field
6. An 8 digit date of call origination field

The SMDR feature is also controlled by hardware switch selection to produce one of two ASCII output formats. This format, either Standard or Mini-Printer, is controlled by Switch 6 on the CPB PCB. Refer to section 400.21 for a description of this switch.

Standard Format The 'Standard Format' output constitutes a 56-character ASCII stream, illustrated below.

AA-BB-DD-EE-CC----- (CR) (LF)
Where:

AA = A 2 digit station call originator field
(range 10-57)

BB = A 2 digit CO line accessed field (range
01-16)

CCC...CCC = A 24 digit collected dial digit field

DD:DD = a 5 digit call duration field (HH:MM)

EE:EE:EE = An 8 digit time of day call origination
(HH:MM:SS)

FF/FF/FF = An 8-digit month, day, and year of call
origination (MM/DD/YY)

-- = Space separators

(CR) = Carriage Return

(LF) = Line Feed

Mini-Printer Format The Mini-Printer output format constitutes a 59-character ASCII Stream illustrated below.

AA-BB-DD-EE-FF-(CR)-(LF)

CC-(CR)-(LF)

(CR) (LF)

Where:

AA = A 2-digit station call originator field
(range 10-57)

BB = A 2-digit CO Line accessed field
(range 10-57)

CCC...CCC = A 24-digit collected dial digit field

DD:DD = A 5-digit call duration Field (HH:mm)

EE:EE:EE = An 8-digit time of day call origination
field (HH:MM:SS)

FF/FF/FF = An 8-digit month, day, and year of call
origination (MM/DD/YY)

-- = Space separators

(CR) = Carriage Return

(LF) = Line Feed

The SMDR feature contains logic to recognize unsatisfied output requests to the RS-232C port (device not attached). Upon recognition of this, it will recycle its resources to retain a queue of its last '16' requests. This function will ensure that the most recent records are retained in the event of terminal failure (i.e. paper alarm, disconnected, etc.).

The SMDR dynamic resources used to collect call data are kept in the area of memory not disturbed during soft

restart.

During Customer Data Base update procedures, if the SMDR feature is enabled, call records will continue to be output. These records will be interleaved between program display lines.

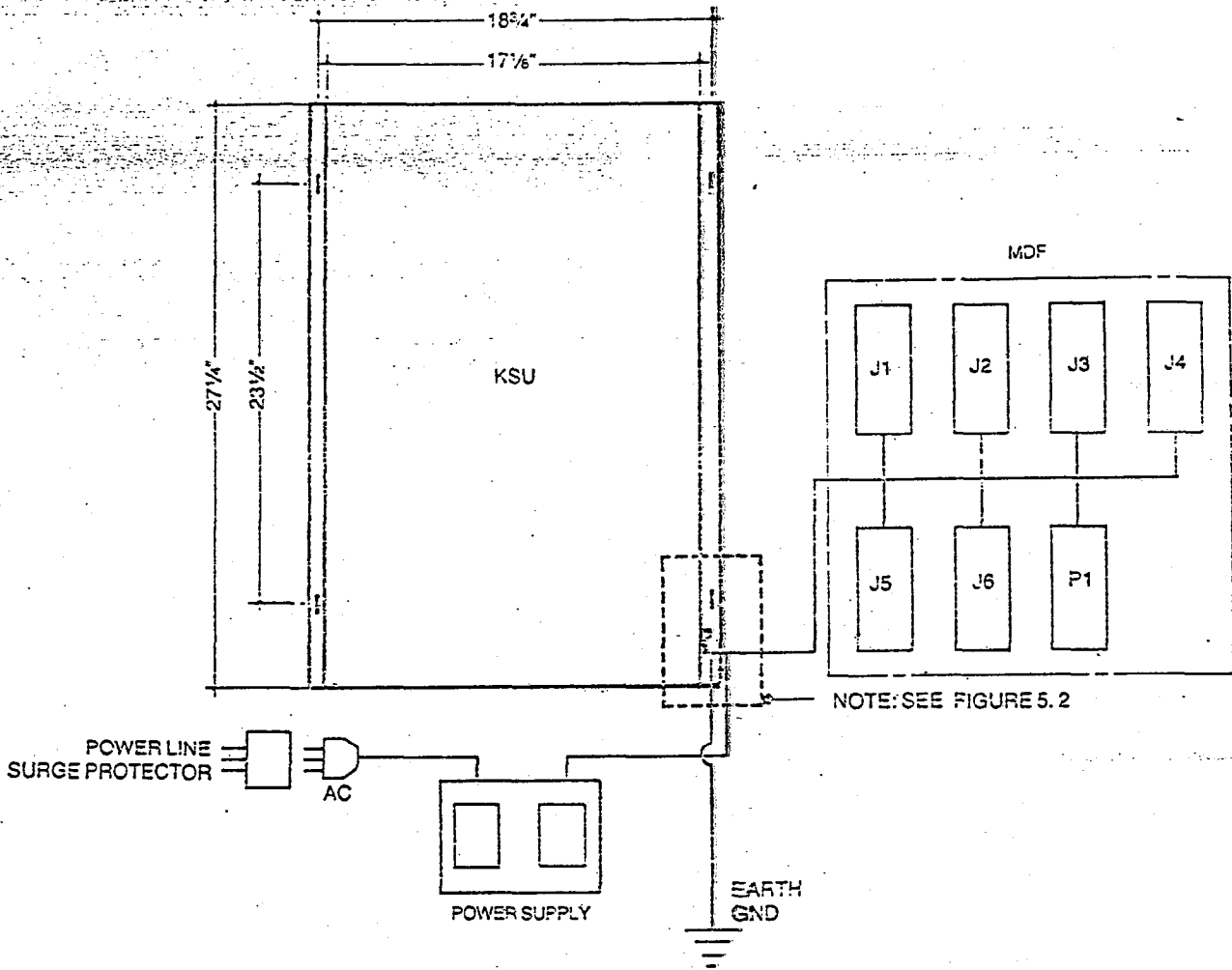

FIGURE 5.1
TYPICAL KSU INSTALLATION

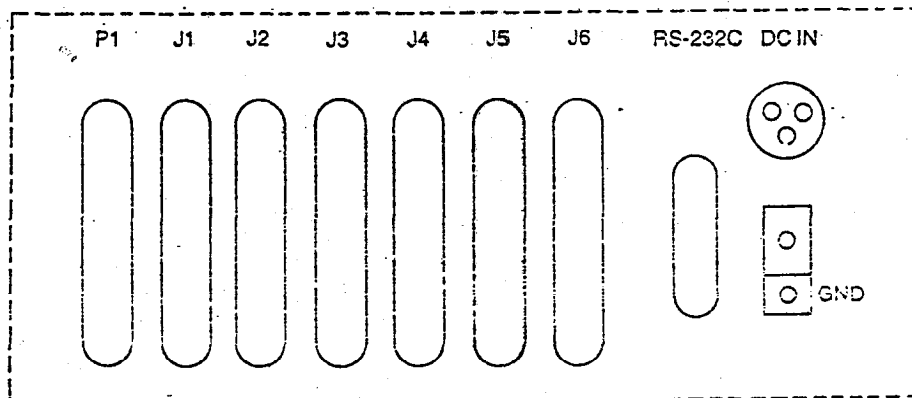

FIGURE 5.2
SIDEVIEW OF KSU

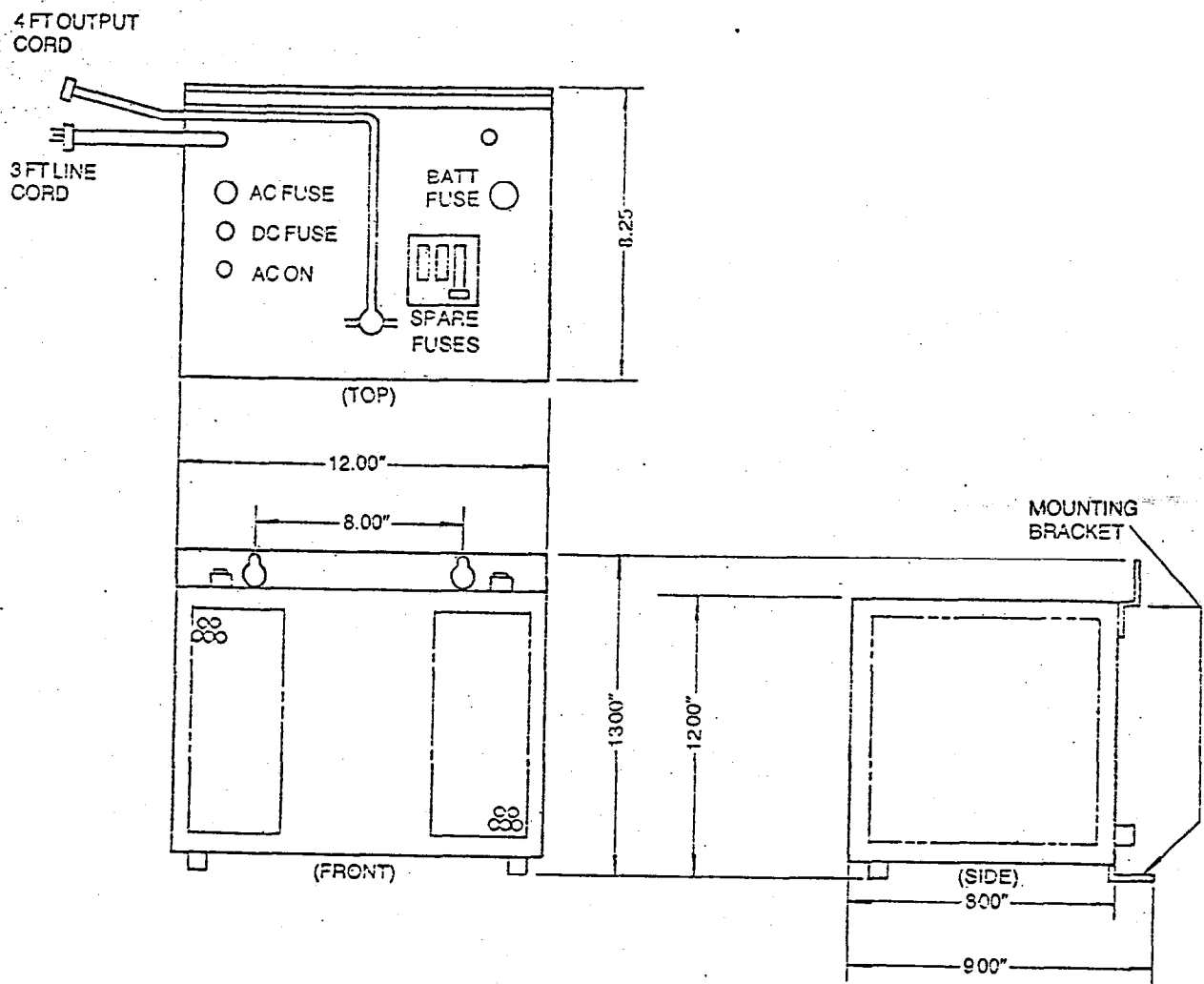

FIGURE 5.3
POWER SUPPLY MOUNTING DIMENSIONS

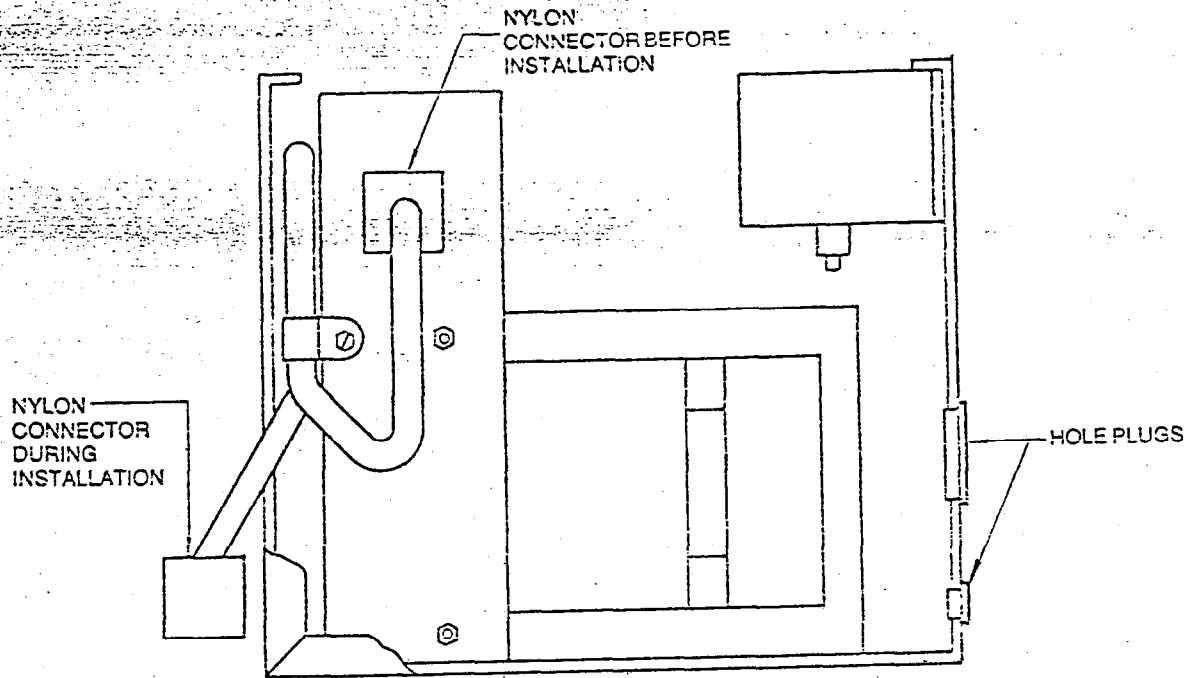

FIGURE 5.4
INSTALLATION OF BCB
(BEFORE INSTALLATION)

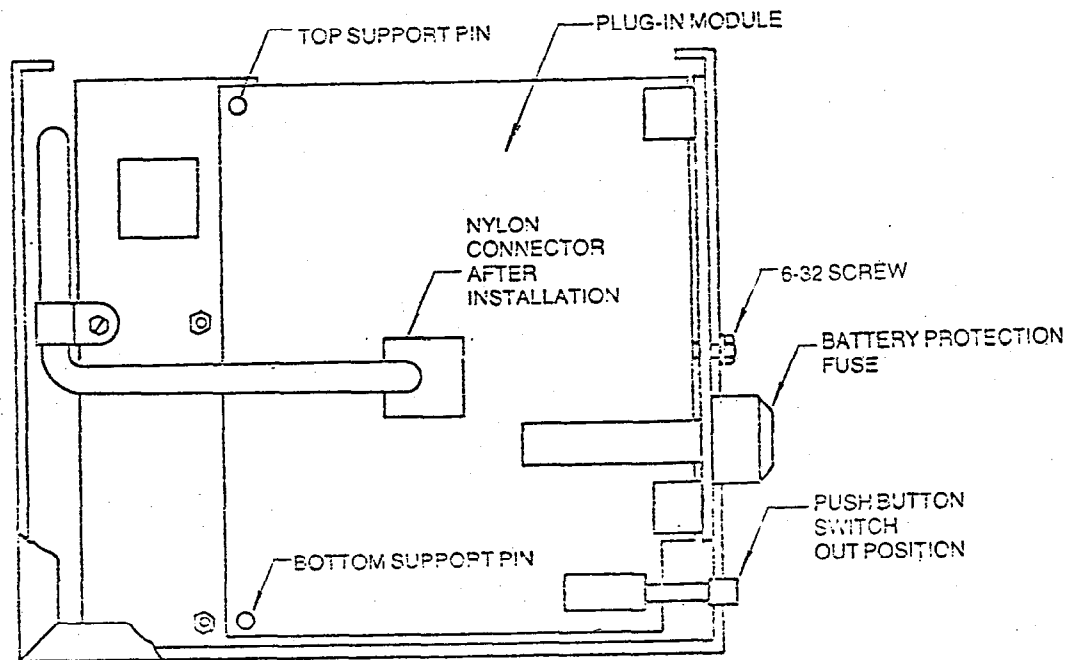
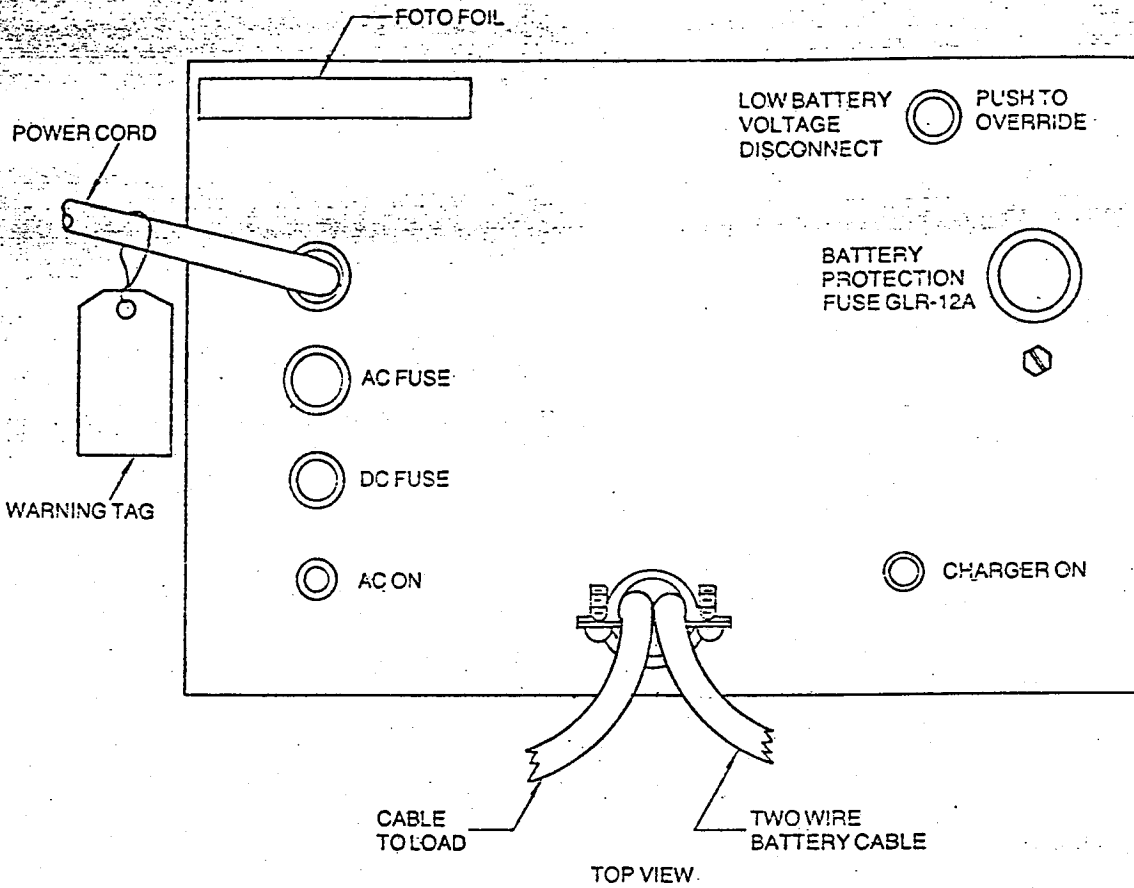
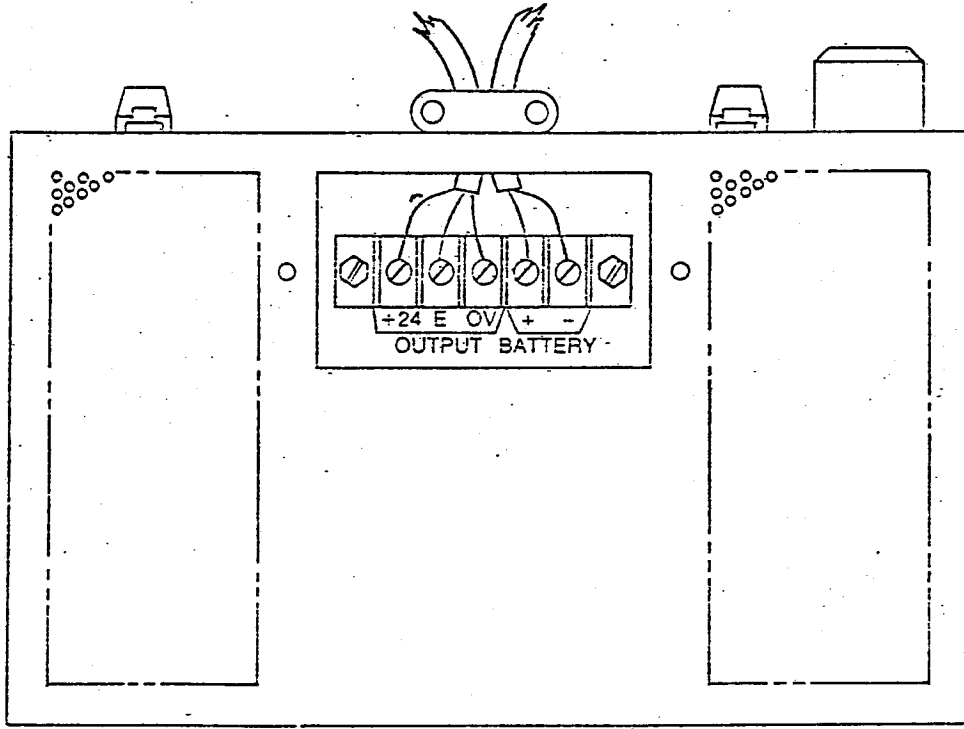

FIGURE 5.5
INSTALLATION OF BCB
(AFTER INSTALLATION)



TOP VIEW



FRONT VIEW WITH ACCESS COVER REMOVED

FIGURE 5.6
TWO WIRE BATTERY CABLE
HOO-K-UP

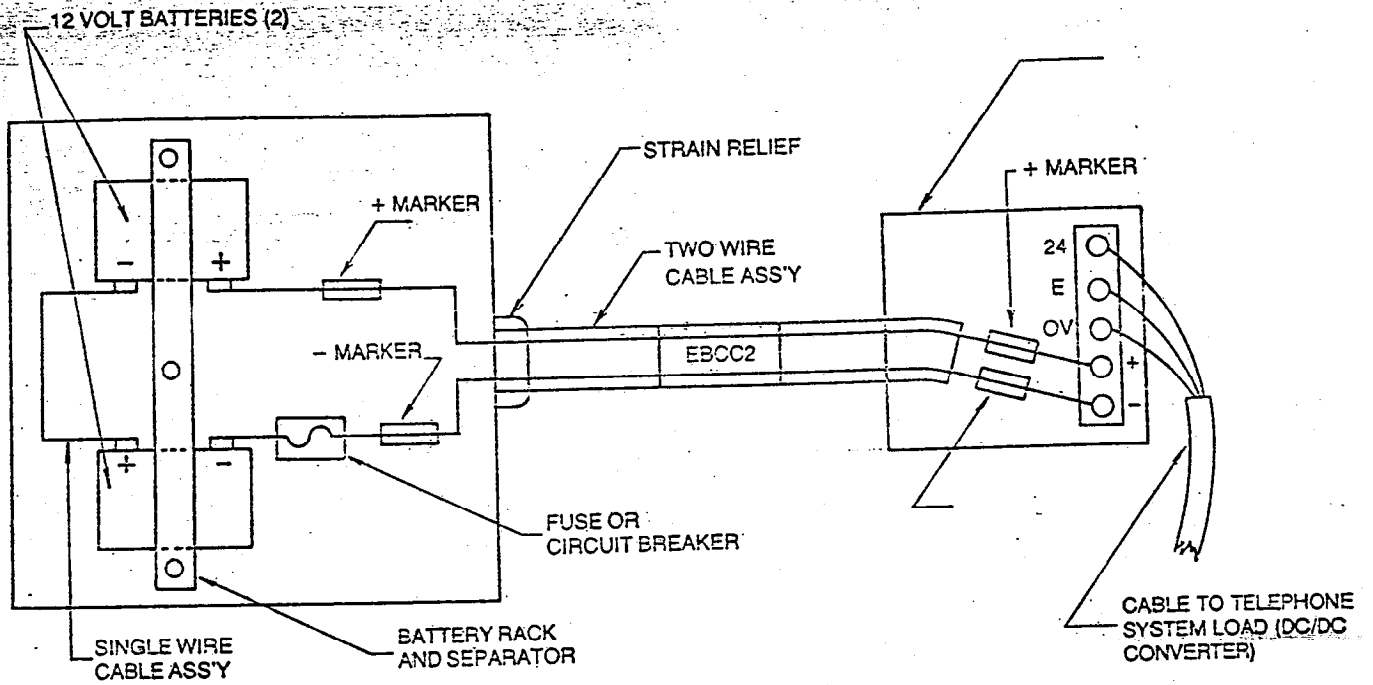

FIGURE 5.7:
TYPICAL SYSTEM
AND INTERCONNECTION LAYOUT

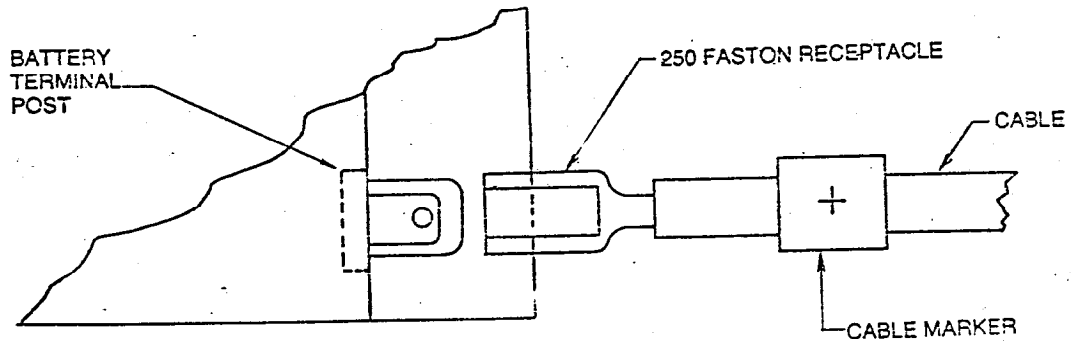

FIGURE 5.8
TYPICAL BATTERY POST
HARDWARE ILLUSTRATION

P-1			
PAIR	PIN	COLOR	DESIG
1	26	W/BL	CO 1T
	1	BL/W	CO 1R
2	27	W/OR	CO 2T
	2	OR/W	CO 2R
3	28	W/GN	CO 3T
	3	GN/W	CO 3R
4	29	W/BR	CO 4T
	4	BR/W	CO 4R
5	30	W/SL	CO 5T
	5	SL/W	CO 5R
6	31	R/BL	CO 6T
	6	BL/R	CO 6R
7	32	R/OR	CO 7T
	7	OR/R	CO 7R
8	33	R/GN	CO 8T
	8	GN/R	CO 8R
9	34	R/BN	CO 9T
	9	BN/R	CO 9R
10	35	R/SL	CO 10T
	10	SL/R	CO 10R
11	36	BK/BL	CO 11T
	11	BL/BK	CO 11R
12	37	BK/OR	CO 12T
	12	OR/BK	CO 12R
13	38	BK/GN	CO 13T
	13	GN/BK	CO 13R
14	39	BK/BR	CO 14T
	14	BR/BK	CO 14R
15	40	BK/SL	CO 15T
	15	SL/BK	CO 15R
16	41	Y/BL	CO 16T
	16	BL/Y	CO 16R
17	42	Y/OR	----
	17	OR/Y	----
18	43	Y/GN	----
	18	GN/Y	----
19	44	Y/BN	----
	19	BN/Y	----
20	45	Y/SL	----
	20	SL/Y	----
21	46	V/BL	----
	21	BL/V	----
22	47	V/OR	----
	22	OR/V	----
23	48	V/GN	----
	23	GN/V	----
24	49	V/BN	----
	24	BN/V	----
25	50	V/SL	----
	25	SL/V	----

FIGURE 5.9
P-1 CONNECTOR
CO/FBX LINE CONNECTIONS

J5			
PAIR	PIN	COLOR	DESIG
1	26	W/BL	CO1T-IN
	1	BL/W	CO1R-IN
2	27	W/OR	CO1T-OUT
	2	OR/W	CO1R-OUT
3	28	W/GN	ST1T-IN
	3	GN/W	ST1R-IN
4	29	W/BR	ST1T-OUT
	4	BR/W	ST1R-OUT
5	30	W/SL	CO2T-IN
	5	SL/W	CO2R-IN
6	31	R/BL	CO2T-OUT
	6	BL/R	CO2R-OUT
7	32	R/OR	ST2T-IN
	7	OR/R	ST2R-IN
8	33	R/GN	ST2T-OUT
	8	GN/R	ST2R-OUT
9	34	R/BN	CO3T-IN
	9	BN/R	CO3R-IN
10	35	R/SL	CO3T-OUT
	10	SL/R	CO3R-OUT
11	36	BK/BL	ST3T-IN
	11	BL/BK	ST3R-IN
12	37	BK/OR	ST3T-OUT
	12	OR/BK	ST3R-OUT
13	38	BK/GN	CO4T-IN
	13	GN/BK	CO4R-IN
14	39	BK/BR	CO4T-OUT
	14	BR/BK	CO4R-OUT
15	40	BK/SL	ST4T-IN
	15	SL/BK	ST4R-IN
16	41	Y/BL	ST4T-OUT
	16	BL/Y	ST4R-OUT
17	42	Y/OR	CO5T-IN
	17	OR/Y	CO5R-IN
18	43	Y/GN	CO5T-OUT
	18	GN/Y	CO5R-OUT
19	44	Y/BN	ST5T-IN
	19	BN/Y	ST5R-IN
20	45	Y/SL	ST5T-OUT
	20	SL/Y	ST5R-OUT
21	46	V/BL	CO6T-IN
	21	BL/V	CO6R-IN
22	47	V/OR	CO6T-OUT
	22	OR/V	CO6R-OUT
23	48	V/GN	ST6T-IN
	23	GN/V	ST6R-IN
24	49	V/BN	ST6T-OUT
	24	BN/V	ST6R-OUT
25	50	V/SL	----
	25	SL/V	----

FIGURE 5.10
J5 CONNECTOR
EMERGENCY TRANSFER

PJ21X
(TELCO)

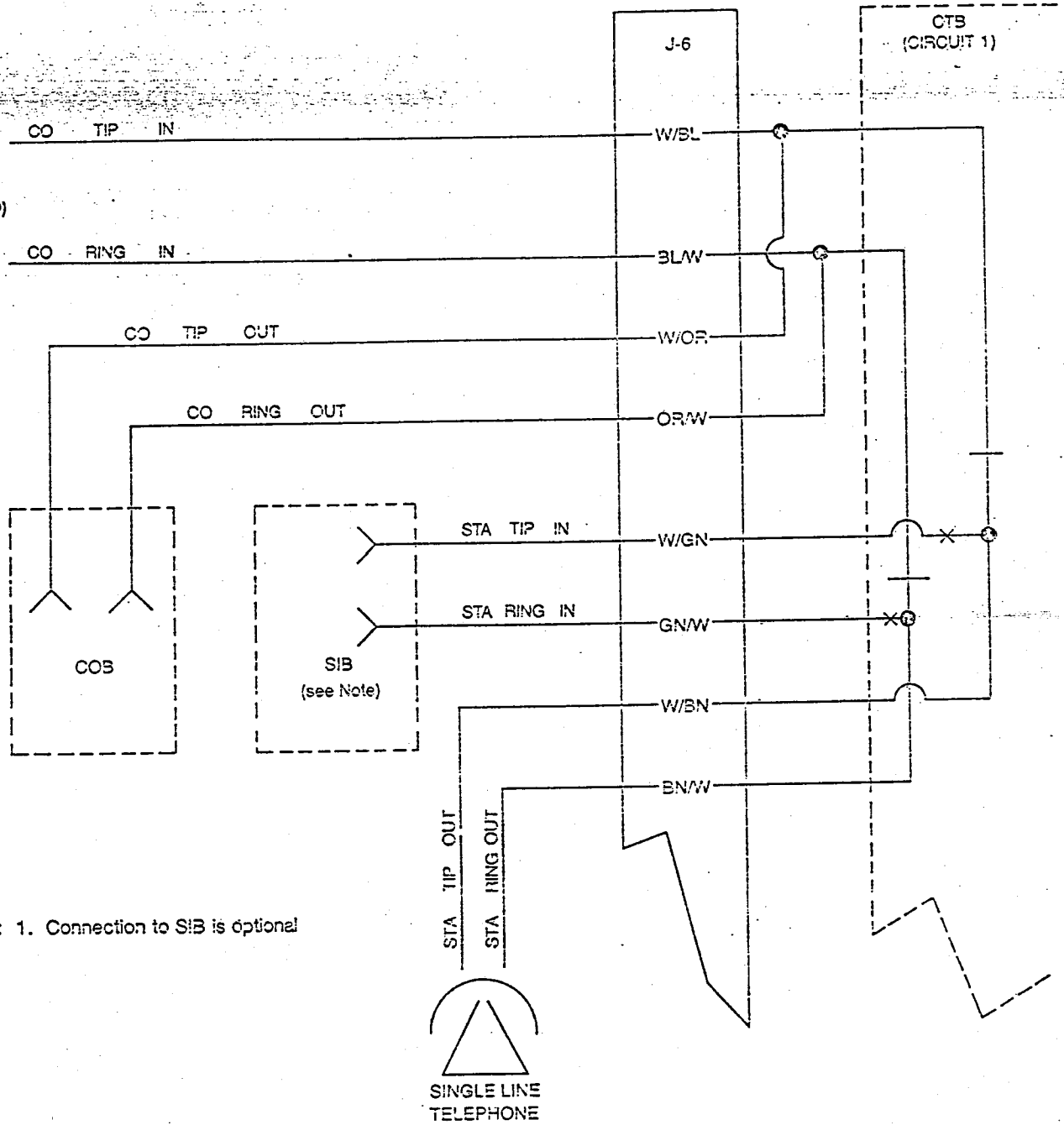

FIGURE 5.11
EMERGENCY TRANSFER CIRCUIT

J1			
PAIR	PIN	COLOR	DESIG
1	26	W/BL	VT10
	1	BL/W	VR10
2	27	W/OR	DT10
	2	OR/W	DR10
3	28	W/GN	VT11
	3	GN/W	VR11
4	29	W/BR	DT11
	4	BR/W	DR11
5	30	W/SL	VT12
	5	SL/W	VR12
6	31	R/BL	DT12
	6	BL/R	DR12
7	32	R/OR	VT13
	7	OR/R	VR13
8	33	R/GN	DT13
	8	GN/R	DR13
9	34	R/BN	VT13
	9	BN/R	VR13
10	35	R/SL	DT14
	10	SL/R	DR14
11	36	BK/BL	VT15
	11	BL/BK	VR15
12	37	BK/OR	DT15
	12	OR/BK	DR15
13	38	BK/GN	VT15
	13	GN/BK	VR15
14	39	BK/BR	DT16
	14	BR/BK	DR16
15	40	BK/SL	VT17
	15	SL/BK	VR17
16	41	Y/BL	DT17
	16	BL/Y	DR17
17	42	Y/OR	VT18
	17	OR/Y	VR18
18	43	Y/GN	DT18
	18	GN/Y	DR18
19	44	Y/BN	VT19
	19	BN/Y	VR19
20	45	Y/SL	DT19
	20	SL/Y	DR19
21	46	V/BL	VT20
	21	BL/V	VR20
22	47	V/OR	DT20
	22	OR/V	DR20
23	48	V/GN	VT21
	23	GN/V	VR21
24	49	V/BN	DT21
	24	BN/V	DR21
25	50	V/SL	----
	25	SL/V	----

J2			
PAIR	PIN	COLOR	DESIG
1	26	W/BL	VT22
	1	BL/W	VR22
2	27	W/OR	DT22
	2	OR/W	DR22
3	28	W/GN	VT23
	3	GN/W	VR23
4	29	W/BR	DT23
	4	BR/W	DR23
5	30	W/SL	VT24
	5	SL/W	VR24
6	31	R/BL	DT24
	6	BL/R	DR24
7	32	R/OR	VT25
	7	OR/R	VR25
8	33	R/GN	DT25
	8	GN/R	DR25
9	34	R/BN	VT26
	9	BN/R	VR26
10	35	R/SL	DT26
	10	SL/R	DR26
11	36	BK/BL	VT27
	11	BL/BK	VR27
12	37	BK/OR	DT27
	12	OR/BK	DR27
13	38	BK/GN	VT28
	13	GN/BK	VR28
14	39	BK/BR	DT28
	14	BR/BK	DR28
15	40	BK/SL	VT29
	15	SL/BK	VR29
16	41	Y/BL	DT29
	16	BL/Y	DR29
17	42	Y/OR	VT30
	17	OR/Y	VR30
18	43	Y/GN	DT30
	18	GN/Y	DR30
19	44	Y/BN	VT31
	19	BN/Y	VR31
20	45	Y/SL	DT31
	20	SL/Y	DR31
21	46	V/BL	VT32
	21	BL/V	VR32
22	47	V/OR	DT32
	22	OR/V	DR32
23	48	V/GN	VT33
	23	GN/V	VR33
24	49	V/BN	DT33
	24	BN/V	DR33
25	50	V/SL	----
	25	SL/V	----

FIGURE 5.12
J1/J2 CONNECTOR - KEY TELEPHONE

J3

PAIR	PIN	COLOR	DESIG
1	26	W/BL	VT34
	1	BL/W	VR34
2	27	W/OR	DT34
	2	OR/W	DR34
3	28	W/GN	VT35
	3	GN/W	VR35
4	29	W/BR	DT35
	4	BR/W	DR35
5	30	W/SL	VT36
	5	SL/W	VR36
6	31	R/BL	DT36
	6	BL/R	DR36
7	32	R/OR	VT37
	7	OR/R	VR37
8	33	R/GN	DT37
	8	GN/R	DR37
9	34	R/BN	VT38
	9	BN/R	VR38
10	35	R/SL	DT38
	10	SL/R	DR38
11	36	BK/BL	VT39
	11	BL/BK	VR39
12	37	BK/OR	DT39
	12	OR/BK	DR39
13	38	BK/GN	VT40
	13	GN/BK	VR40
14	39	BK/BR	DT40
	14	BR/BK	DR40
15	40	BK/SL	VT41
	15	SL/BK	VR41
16	41	Y/BL	DT41
	16	BL/Y	DR41
17	42	Y/OR	VT42
	17	OR/Y	VR42
18	43	Y/GN	DT42
	18	GN/Y	DR42
19	44	Y/BN	VT43
	19	BN/Y	VR43
20	45	Y/SL	DT43
	20	SL/Y	DR43
21	46	V/BL	VT44
	21	BL/V	VR44
22	47	V/OR	DT44
	22	OR/V	DR44
23	48	V/GN	VT45
	23	GN/V	VR45
24	49	V/BN	DT45
	24	BN/V	DR45
25	50	V/SL	DT45
	25	SL/V	DR45

J4

PAIR	PIN	COLOR	DESIG
1	26	W/BL	VT46
	1	BL/W	VR46
2	27	W/OR	DT46
	2	OR/W	DR46
3	28	W/GN	VT47
	3	GN/W	VR47
4	29	W/BR	DT47
	4	BR/W	DR47
5	30	W/SL	VT48
	5	SL/W	VR48
6	31	R/BL	DT48
	6	BL/R	DR48
7	32	R/OR	VT49
	7	OR/R	VR49
8	33	R/GN	DT49
	8	GN/R	DR49
9	34	R/BN	VT50
	9	BN/R	VR50
10	35	R/SL	DT50
	10	SL/R	DR50
11	36	BK/BL	VT51
	11	BL/BK	VR51
12	37	BK/OR	DT51
	12	OR/BK	DR51
13	38	BK/GN	VT52
	13	GN/BK	VR52
14	39	BK/BR	DT52
	14	BR/BK	DR52
15	40	BK/SL	VT53
	15	SL/BK	VR53
16	41	Y/BL	DT53
	16	BL/Y	DR53
17	42	Y/OR	VT54
	17	OR/Y	VR54
18	43	Y/GN	DT54
	18	GN/Y	DR54
19	44	Y/BN	VT55
	19	BN/Y	VR55
20	45	Y/SL	DT55
	20	SL/Y	DR55
21	46	V/BL	VT56
	21	BL/V	VR56
22	47	V/OR	DT56
	22	OR/V	DR56
23	48	V/GN	VT57
	23	GN/V	VR57
24	49	V/BN	DT57
	24	BN/V	DR57
25	50	V/SL	DT57
	25	SL/V	DR57

FIGURE 5.13
J3/J4 CONNECTOR - KEY TELEPHONE
SINGLE LINE TELEPHONE

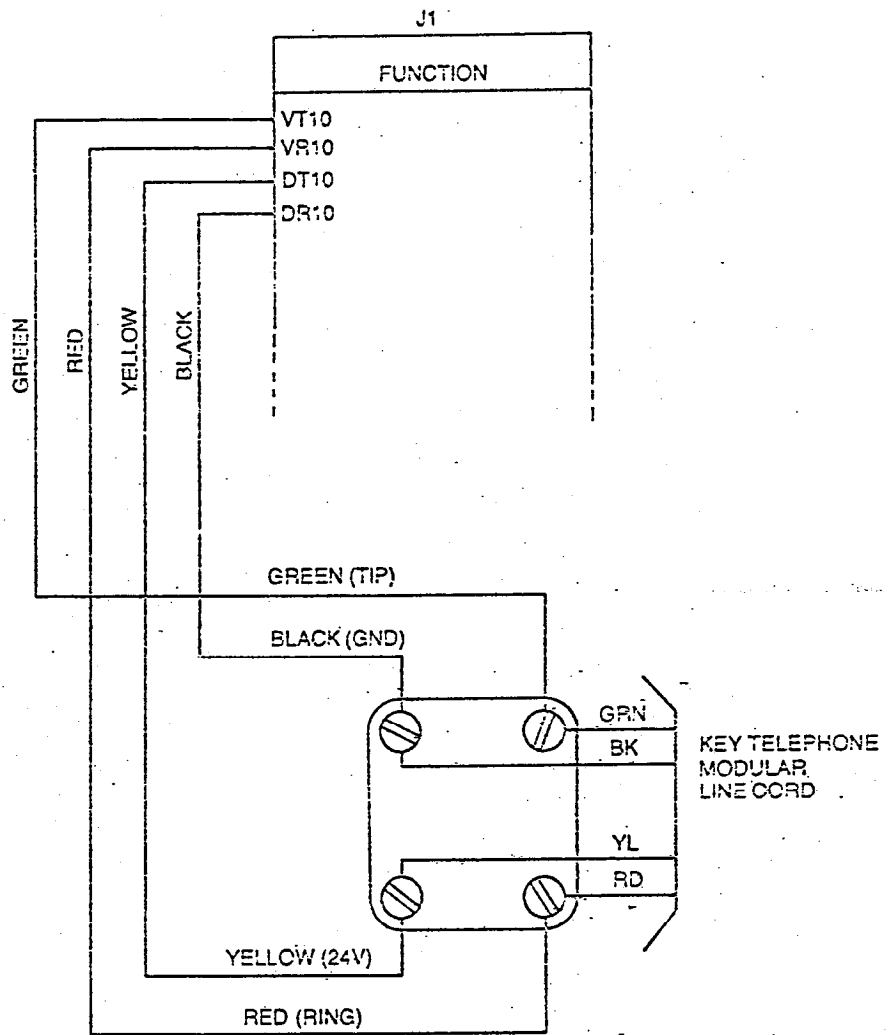

CAUTION: Observe Polarity of YELLOW (+ 24V) and BLACK (GND) at key telephone modular jack.

FIGURE 5.14
KEY TELEPHONE WIRING

J5			
PAIR	PIN	COLOR	DESIG
1	26	W/BL	PRT-24V
	1	BL/W	PRT GND
2	27	W/OR	PRT TXD
	2	OR/W	PRT RXD
3	28	W/GN	DSS1-DT1
	3	GN/W	DSS1-DR1
4	29	W/BR	DSS1-24V
	4	BR/W	DSS1-GND
5	30	W/SL	DSS1-DT2
	5	SL/W	DSS1-DR2
6	31	R/BL	DSS2-DT1
	6	BL/R	DSS2-DR1
7	32	R/OR	DSS2-24V
	7	OR/R	DSS2-GND
8	33	R/GN	DSS2-DT2
	8	GN/R	DSS2-DR2
9	34	R/BN	PG2-CTLB
	9	BN/R	PG2-CTLB
10	35	R/SL	PG2-CTLM
	10	SL/R	PG2-CTLM
11	36	BK/SL	PG2-T
	11	BL/BK	PG2-R
12	37	BK/OR	PG1-CTLB
	12	OR/BK	PG1-CTLB
13	38	BK/GN	PG1-CTLM
	13	GN/BK	PG1-CTLM
14	39	BK/BR	PG1-T
	14	BR/BK	PG1-R
15	40	BK/SL	LBCTL
	15	SL/BK	LBCTL
16	41	Y/BL	BGM2-T
	16	BL/Y	BGM2-R
17	42	Y/OR	BGM1-T
	17	OR/Y	BGM1-R
18	43	Y/GN	BLF 1-3
	18	GN/Y	BLF 1-3
19	44	Y/BN	BLF 1-3
	19	BN/Y	BLF 1-3
20	45	Y/SL	BLF 1-3
	20	SL/Y	BLF 1-3
21	46	V/BL	BLF 4-6
	21	BL/V	BLF 4-6
22	47	V/OR	BLF 4-6
	22	OR/V	BLF 4-6
23	48	V/GN	BLF 4-6
	23	GN/V	BLF 4-6
24	49	V/BN	----
	24	BN/V	----
25	50	V/SL	----
	25	SL/V	----

FIGURE 5.15
CONNECTOR - MISCELLANEOUS
CONNECTIONS

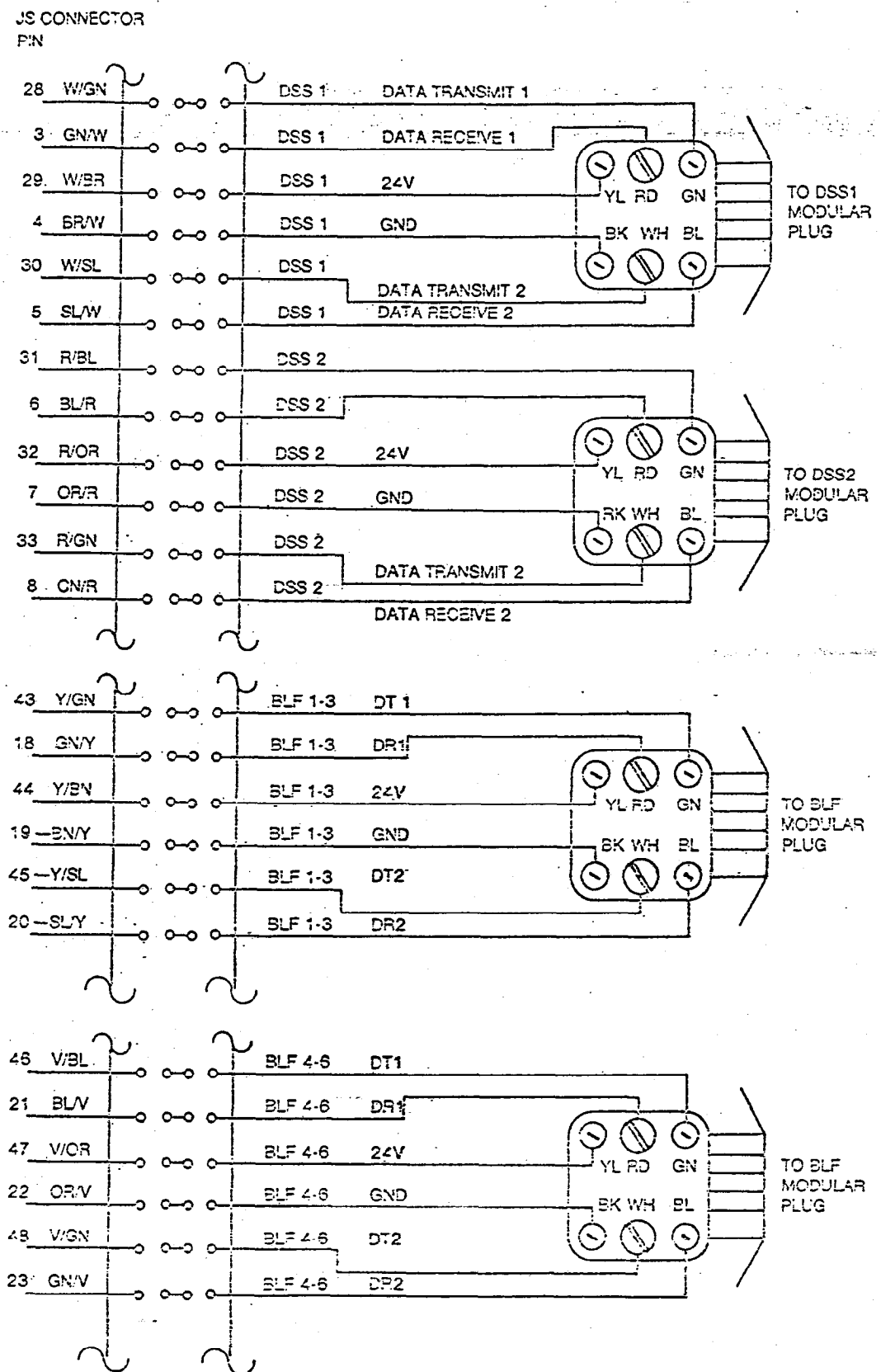

FIGURE 5.16
DIRECT STATION SELECTION (DSS)
BUSY LAMP FIELD (BLF)
CONNECTIONS

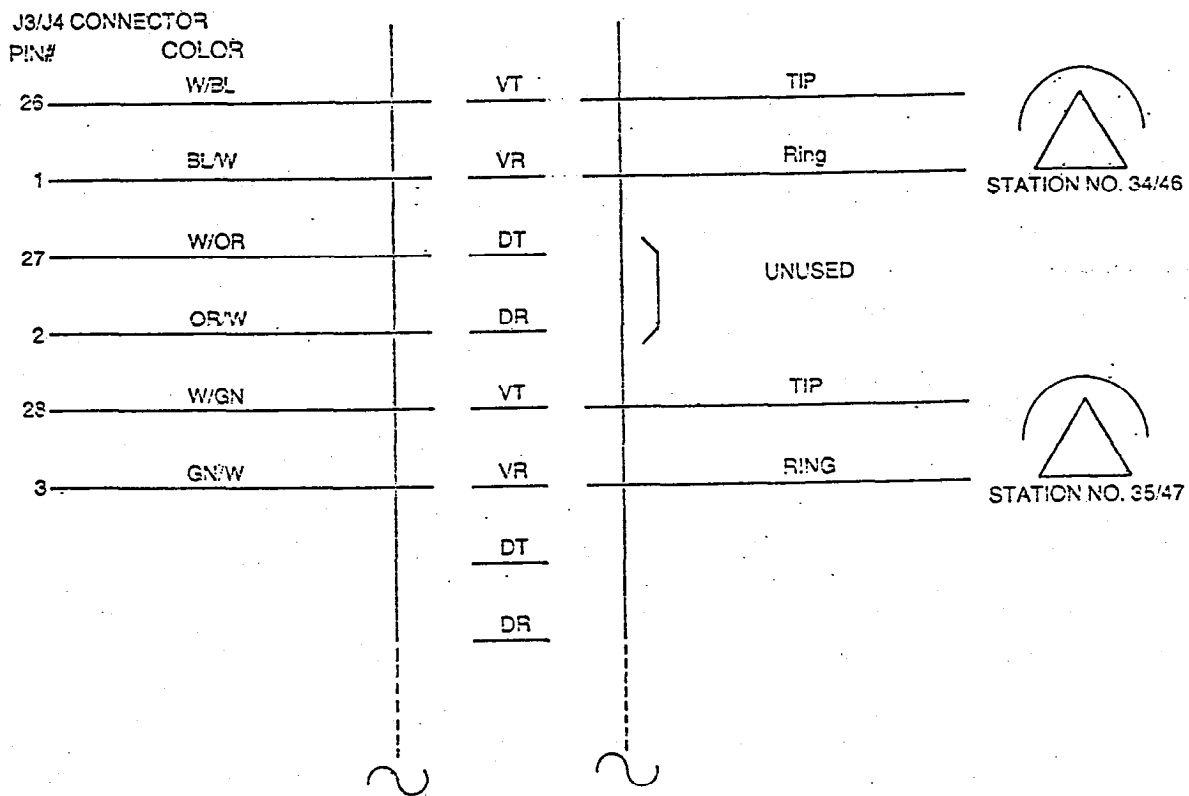
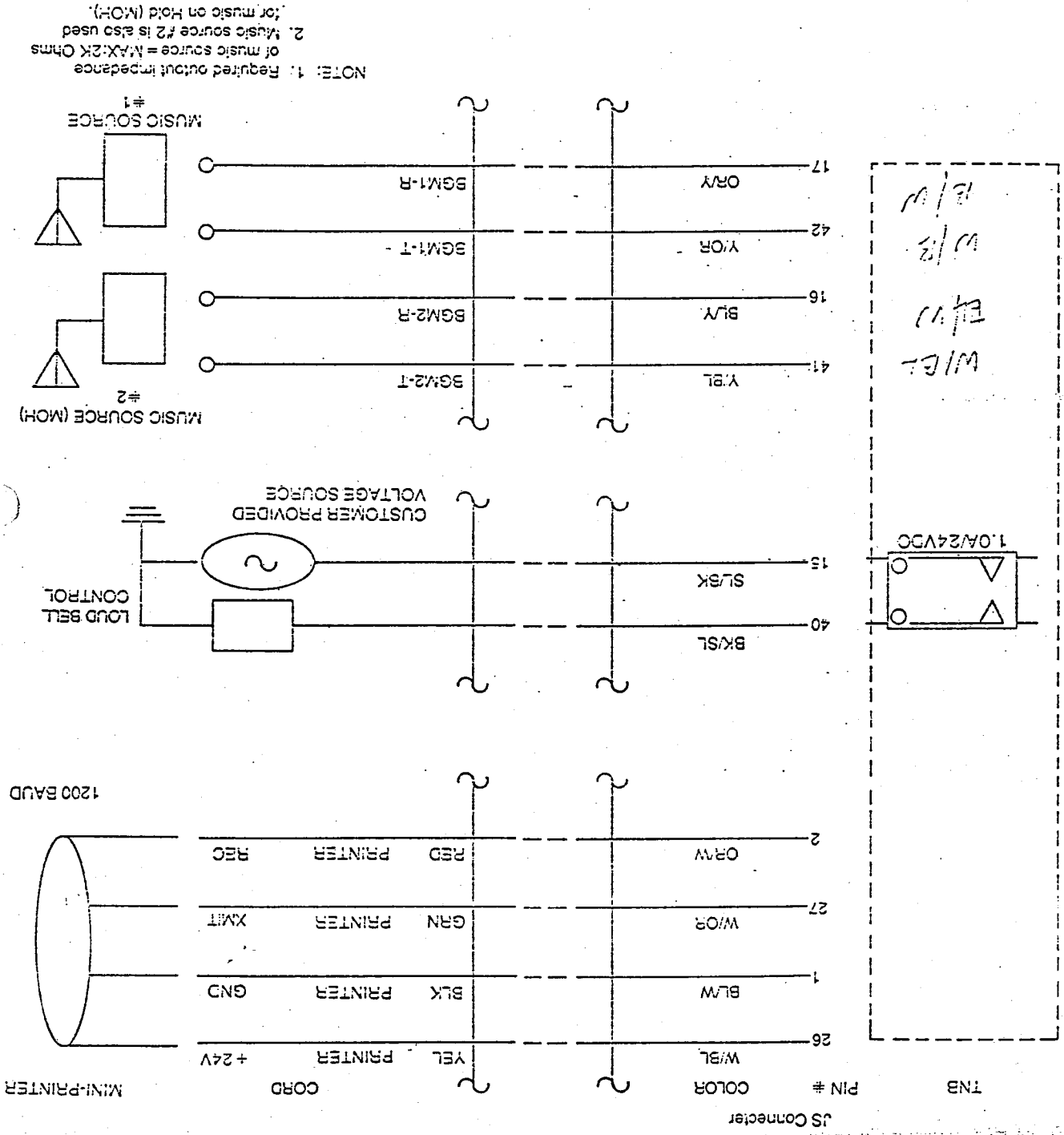

FIGURE 5.17
TYPICAL CONNECTOR OUTPUT WIRING
WITH SIB INSTALLED

FIGURE 518
 INSTALLATION OF MINI-PRINTER, LOUD
 BELL CONTROL, AND MUSIC SOURCES



NOTE: 1. Required output impedance of music source = MAX:2K Ohms
 2. Music source #2 is also used for music on Hold (M/OH).

1200 BAUD

MINI-PRINTER

CORD

JS Connector

TNB

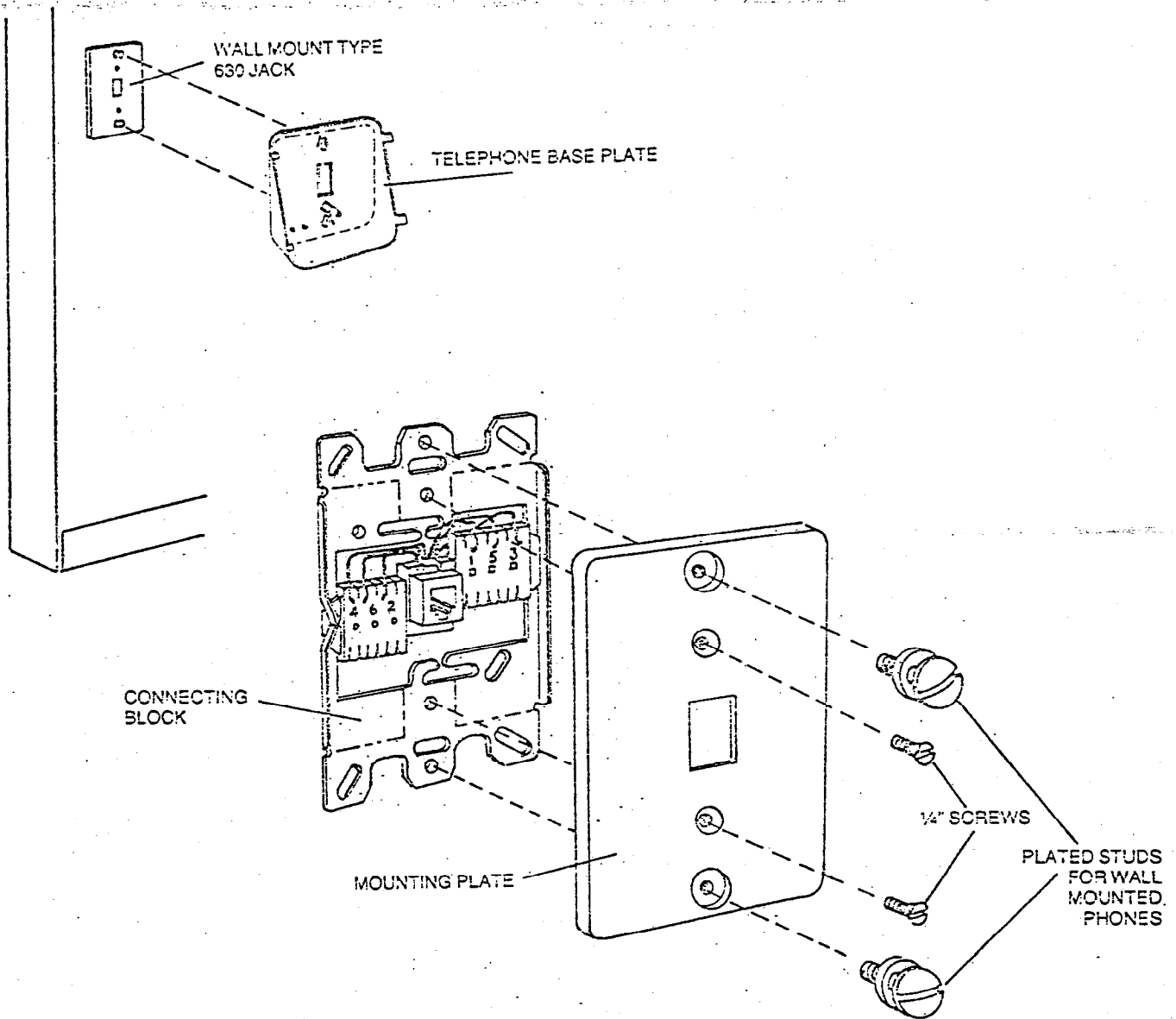
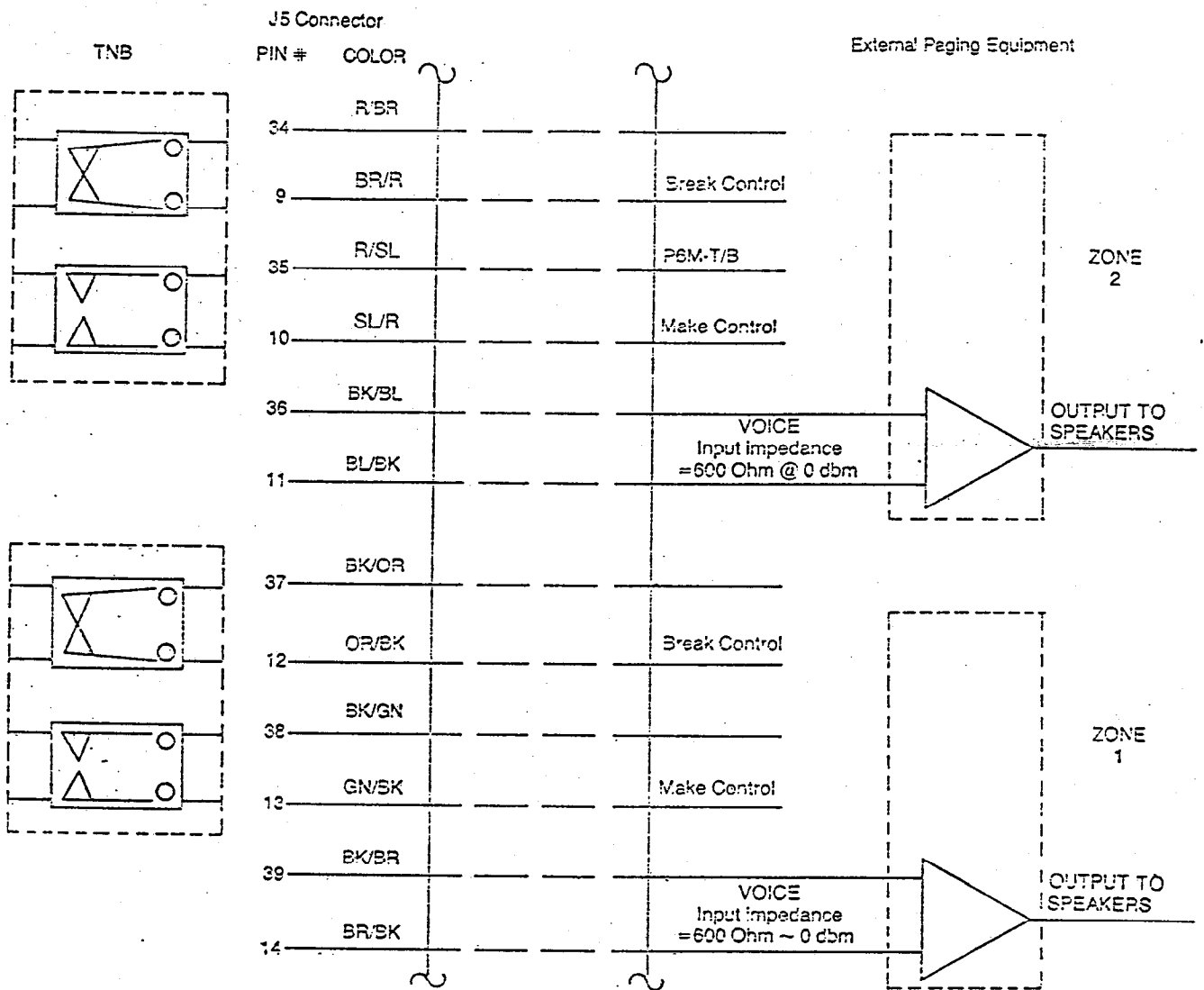

FIGURE 5.19
TYPE 630 WALL MOUNT JACK



NOTE: Dry contacts located on tone board rated at 5A ~ 24 VDC

FIGURE 5.20
INSTALLATION OF EXTERNAL PAGING ZONES

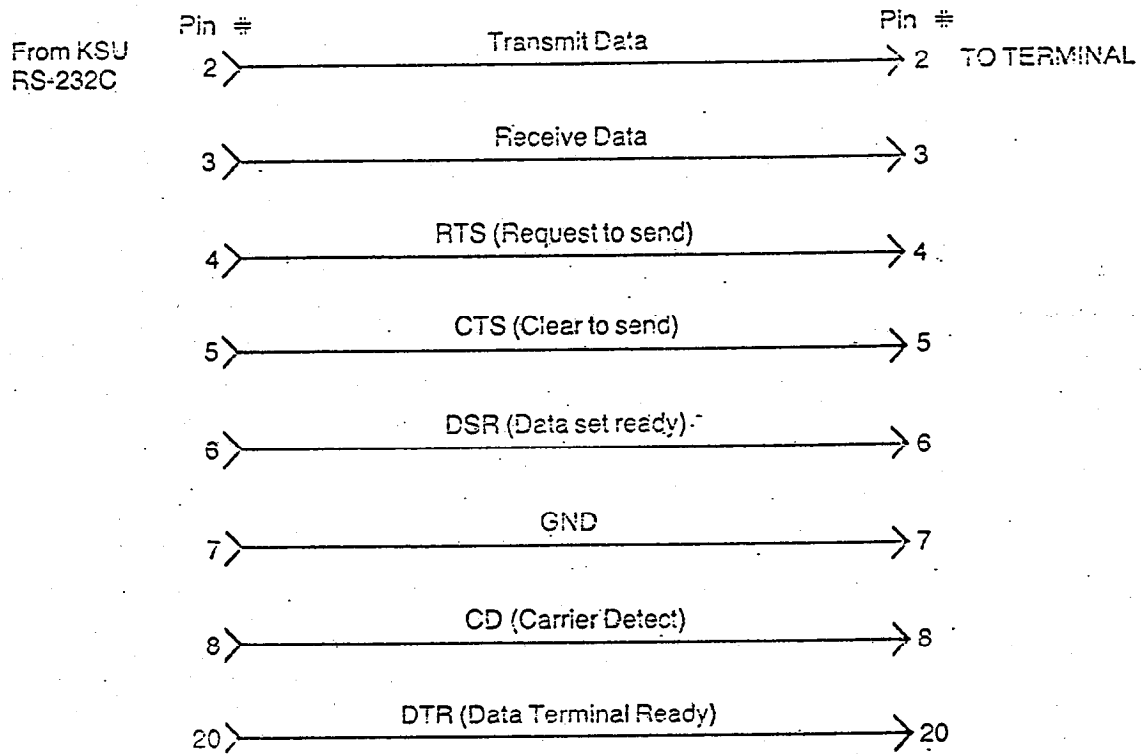

FIGURE 5.21
RS-232 CONNECTIONS

600 INITIALIZATION**600.10 INSTALLATION CHECK LIST**

Prior to actual power-up and initialization, the key system should be checked over to avoid start up delays or improper loading. A step-by-step check list is provided for this purpose.

- A) Verify that the DC output power cord from the external power supply is plugged into the DC IN connector on the KSU.
- B) Ensure that the KSU is properly grounded according to the instructions in Section 500.33.
- C) The DC/DC Converter located inside the KSU should be firmly seated into its card connector position and the "ON/OFF" rocker switch should be in the "OFF" position.
- D) Verify that all KTU's are firmly plugged into their correct card slot positions. This is easily done by comparing the color of the KTU ejector tabs with the colored adhesive labels on the KSU card shelves. Refer to Section 400.10 for additional information.
- E) Check the Service switches on the associated KTU's. The switches should be operated to the up position (NORMAL mode).
- F) Inspect the MDF for shorted wiring or improper polarity that would affect the Key Telephones or DSS consoles.
- G) On the CPB, the write memory switch (DIP switch #1), should be to the right (ON) position to enable the boot strap loading of default data into the system memory, upon system power-up. Check the remaining DIP switches to verify that the switch settings conform to the parameters listed in Section 400.21. The lithium battery should be properly connected to the battery (+) terminal.
- H) Make sure that plug-ended MDF cables connected to the KSU are secure and are plugged into the correct positions.

600.20 POWER UP SEQUENCE

The power up sequence involves the proper application of AC power to the system, monitoring DC/DC Converter LED's and observing the LED's located on the CPB. A successful power up sequence is assured if the Installation Check List (Section 600.10) has been followed. When system power is applied, a boot strap operation

loads the system memory with default data base information. System diagnostics are also executed. The diagnostic tests involve CPU tests, EPROM verification, RAM tests, fuse checks, CODEC/filter tests and other miscellaneous program tests.

The power up sequence describes installer actions and the normal results of these actions.

- A) Plug the AC power cord of the external power supply into the dedicated 117VAC outlet.
- B) Turn "ON" the power switch located on the front of the DC/DC Converter.
- C) The red LED's on the DC/DC Converter should light immediately. The "+24V" LED indicates that the DC/DC Converter is being supplied power by the external power supply. The "+5V and -5V" LED should light to indicate presents of logic voltages.
- D) The green busy indicator LED's on equipped COB cards will randomly light and should then go dark.
- E) The red busy indicator LED's on equipped KIB card's will light until the initialization process is completed. If any KIB's remain lit, the installer should check for a Key Telephone that is off-hook.
- F) The red busy indicator LED on the CNB card(s) will be lit for a brief period of time and then it will go dark.
- G) The CPB has eight (8) red LED's located along the front edge of the card. All eight should be lit following a successful initialization of the system. After a brief time period, the system memory will be loaded with the default data base and the system should be operational. LED-7 should be cycling (flashing) at a slow rate. If any CPB LED's are dark, refer to Section 900.20 for a description of the CPB monitor LED function.
- H) If the above sequences occur, the system is ready for programming. See Section 700. If any problems have occurred, see Section 800 — Operational Tests should be referenced. Section 900 — Trouble-Shooting for maintenance information on the NC-1648 Key Telephone System.

700 CUSTOMER DATA BASE PROGRAMMING

700.10 INTRODUCTION

The customer data base consists of the parameters necessary to configure a customer's system. A chart of the configuration data and associated default values is provided in Table 7.1.

The data programming function is performed by utilizing the DSS Unit (#1) as a data entry/display device. Optional printers may also be used to display this information.

The DSS buttons/LED'S are redefined by software into three distinct fields.

1. **Command Field:** This field is used to select the overlays and functions required.
2. **Key Pad:** Used to enter numeric data.
3. **Overlay Unique:** Determined by the overlay being

used, each overlay contains unique fields for selecting data elements and entering configuration information.

700.20 GENERAL

The Premier NC-1648 is programmed via the DSS Console. At the choice of the user, default data may be implemented or if necessary, customer data can be generated to suit a particular need.

The programming functions in this section are divided into five major categories.

1. System Parameters
2. CO Lines
3. Stations
4. System Speed Dial
5. Exception Tables

Table 7.1
DEFAULT CONFIGURATION DATA

FUNCTION	DEFAULT VALUE
Outgoing CO Line Groups (7)	All CO Lines in Group 1
Transfer Recall Timer	Time is set at 60 seconds
Ex-Hold Recall Timer	Time is set at 60 seconds
Station Do-Not-Disturb Mode	DND is enabled for all key station
Flash Timer	Time is set at 2.0 seconds
Executive/Secretary Pairs (4)	None assigned
CO Line Ringing (Day)	All lines ring at Station 10
CO Line Ringing (Night)	No stations assigned
Internal paging/Call Pick-Up Zones	All stations in Zone 1
System Speed Numbers	None assigned
Station Class of Service	All stations set at COS 0
Toll Restriction Override	Disabled for all CO Lines
PBX Dialing—One Digit	Disabled for all CO Lines
PBX Dialing—Two Digits	Disabled for all CO Lines
System Hold Recall Timer	Time is set at 600 seconds
Internal/External Paging Time out	Time is set at 60 seconds
System Speed Access	Enabled for all stations
Conference Time out	Time is set at 90 minutes
System Time	Time is stored from last power-up
Diagnostic Start Time	Time is set at 2525 Hrs.
External Night Ring	Disabled
Attendant Override	Disabled
System Date	Set at 84-01-01
Loud Bell Control	Set for night only
Baud Rate Select	Set at 300 baud
Universal Night Answer	Enabled for all CO lines

The following section provides information on completing the data base programming forms for each program overlay. Subsequent sections instruct on proper procedure for data entry and update.

700.30 CUSTOMER DATA BASE PROGRAMMING (FORMS)

700.31 IMPLEMENTATION

Before any attempt at programming is initiated, a completed set of customer database sheets should be prepared and be available during programming. Figures 7.1 through 7.5 are examples of the data base sheets currently being used. Refer to these examples while reviewing the following information.

700.32 SYSTEM PARAMETERS OVERLAY

The System Parameters Overlay provides all information necessary to change or update the system timers and/or controllable features. The following is a brief description of those items affected (Refer to Figure 7.1).

1. **Exclusive Hold Recall:** This entry reflects the time elapsed before a call placed on exclusive hold will recall the station activating this feature. If unanswered for the same elapsed time this call will then ring the attendant. The default value is set at 060 seconds and is variable from 001 to 255 seconds. The entry format requires three (3) digits. This timer can be deactivated by entering '000' as the timer value.
2. **Transfer Recall:** This entry reflects the time elapsed before an unanswered call transfer is recalled to the station that initiated the transfer. If unanswered for the same elapsed time this call will then ring the attendant. The default value is set at 060 seconds and is variable from 001 to 255 seconds. The entry format requires three (3) digits. This timer can be deactivated by entering '000' as the timer value.
3. **System Hold Recall:** This entry reflects the time elapsed before an unanswered system hold is recalled to the station that initiated the system hold. If unanswered for the same elapsed time this call will then ring the attendant. The default value is set at 600 seconds and is variable from 001 to 600 seconds. The entry format requires three (3) digits. This timer can be deactivated by entering '000' as the timer value.
4. **Flash Timer:** This timer reflects the duration of a simulated hookswitch flash. This feature has particular applications when the 1648 is interfaced with an EPABX. The default value is two (2) seconds. The value must be

entered in a two (2) digit format (i.e. 20 equals 2 seconds, 15 equals 1.5 seconds). References to the min/max values of the associated EPABX should be made when setting this timer. This timer can be deactivated by entering '00' as the timer value.

5. **Paging Time-Out:** This timer determines the amount of time all paging circuits will stay seized. This includes both internal and external zones. When setting this timer, the maximum length of a page should be considered. The default value is set at 60 seconds and is variable from 01-99 seconds. This timer can be deactivated by entering '00' as the timer value.

6. **Conference Timeout:** This timer reflects the amount of time the conference circuit will remain active if the initiator of the conference is no longer in the circuit. A warning tone will be presented to the remaining users 15 seconds prior to shutdown. The default value is set at 090 minutes and is variable between 001-090 minutes. The entry format requires a three digit entry. The timeout clock is automatically reset to zero whenever the conference initiator re-enters the conference. This timer can be deactivated by entering '000' as the timer value.

7. **Executive/Secretary:** Four Executive/Secretary Pairs are available for programming. When the executive is in Do-Not-Disturb or busy, all calls will be re-routed to the assigned secretary(ies). In the case of one executive using four (4) secretaries, the call is routed to the first available answer point in order of entry. If a busy is encountered on all answer points, the call is redirected to the first secretary.

8. **System Time:** This entry allows the setting of the system clock. This internal clock is referenced when the diagnostic start time is initiated. The entry format requires a four (4) digit entry (i.e. HHMM, where HH=hours and MM=minutes). The time should be entered in a 24 hour format.

9. **Diagnostic Start Time:** This entry is the actual time (24 hour format) that on-line diagnostics will begin. The default value is set at 2525 hours. This invalid time effectively disables on-line diagnostics.

10. **External Night Ring:** This parameter when set at 'YES' activates the external night ring feature. When the CO Line UNA feature is also set to 'YES', tone will be output to both external paging ports when an incoming call occurs on that line during night mode operation.

11. **Attendant Override:** This parameter when set at 'YES' activates the attendant override feature, allowing DND override tone and CO line delayed (5 sec.) barge-in at both DSS positions (DSS 1/2).

12. **System Date:** Enter the correct date in YY/MM/DD format where YY=current year, MM=current month, and DD=current day.

13. **Loud Bell Control:** Setting this parameter to 'YES' and setting the individual CO Line 'UNA' to 'YES' allows external bell control in both day and night mode. Setting this parameter to 'NO' and setting the individual CO Line 'UNA' to 'YES' allows external bell control in the night only mode. When connected, the LBC contact closure will provide an interrupted sequence of one second on (closed) and four seconds off (open).

14. **Baud Rate Select:** This parameter controls the baud rate for the printer output. F=Fast or 1200 baud. S=Slow or 300 baud. The default setting for this parameter is 300 baud. When displayed on the DSS Console, the LED will be lit for 300 baud and extinguished for 1200 baud.

700.33 CO LINE OVERLAY

The CO Line Overlay contains all items necessary to program CO/PBX lines into the 1648 system. The following is a brief description of the items required for entry (See Figure 7.2).

1. **Group:** Eight groups are available for CO Line assignment. Trunk group numbers should be assigned according to trunk type (i.e. Local, WATS, FX, etc.). For valid trunks, groups 1-7 are available for use. All uninstalled trunks should be designated as group '0'. This is accomplished by removing the associated trunks from any groups.

2. **Day Ring Station #:** Eight (8) key telephones can be assigned to ring on each CO Line. If a station is selected to ring during the day, it will automatically ring on the same lines during night service mode.

3. **Night Ring Station #:** Five (5) key telephones can be assigned to ring on each CO line during night mode operation. This number is in addition to the eight stations that are assigned to ring during daytime hours.

4. **PEX Dialing:** This entry reflects the number of digits required to access a CO trunk when the NO-1648 Key System is interfaced with PEX lines. In cases where multiple access codes are used, choose 1 or 2 digits but not both. This entry is used to determine the number of digits to ignore for purposes of toll restriction. When one of these values is selected, a pause is automatically inserted during last number redial operation.

5. **Toll Restriction Override:** This entry, when designated as 'YES', allows the user to defeat toll restriction on the selected line if access is allowed.

6. **UNA:** A 'YES' entry allows night service pick-up of incoming CO/PBX calls on UNA assigned lines from single line telephones. Key telephones not normally assigned access to the CO Lines because of line group access restrictions can "pick up" on the specified CO lines by direct button access.

700.34 STATION OVERLAY

The Station Overlay contains all items necessary to program each individual station into the 1648 system. The following is a brief description of the items required for entry (See Figure 7.3).

1. **Class of Service:** Enter the correct class of service required for this station number. Class of Service definitions are as follows:

Class 0—Unrestricted usage of long distance, local and intercom dialing digits.

Class 1—The first eight dialed digits are compared to the DENY1/ALLOW1 tables for violation checks. Intercom numbers are allowed.

Class 2—The first eight dialed digits are compared to the DENY2/ALLOW2 tables for violation checks. Intercom numbers are allowed.

Class 3—Seven (7) digit local area dialing and intercom numbers allowed only. No '0' or '1' dialing on the first or second digit dialed.

Class 4—Only intercom numbers are allowed.

Class 5—No dialing service of any type. Receive-only operation is allowed.

2. **Page/Pick-up Zone:** Enter the assigned intercom page zones for each key telephone. Users may receive all zones or, by not assigning any zone, be restricted from receiving any paging announcements. This entry reflects which key telephones will be paged when the Zone or All Call feature is used.

The Zones selected above also serve as the corresponding Intercom Call Pick-Up zones for the defined key telephones and S.L.T.'s.

3. **Line Group:** Enter appropriate line group(s) each station is allowed to access. This entry should reflect the CO-Line Groups established on the CO Line Overlay sheet.

4. **DND:** A 'YES' entry indicates that this station is allowed the Do-Not-Disturb feature.

5. **Sys-Speed:** A 'YES' entry indicates that this station is allowed the System Speed Dial feature. Each Speed Dial entry may contain 24 digits including pauses. Toll restriction does not apply to system speed numbers.

700.35 SYSTEM SPEED DIAL OVERLAY

The System Speed Dial Overlay contains all items necessary to program System Speed Dial numbers. The following is a brief description of this feature and instructions for implementation (Refer to Figure 7.4).

1. **Bin Number:** There are 36 bin locations available for speed dial entry. These bins or locations are numbered 10 through 45.
2. **Telephone Number:** Telephone numbers entered can be a maximum of 24 digits. A pound (#) is used whenever a pause is desired and is counted as one of the 24 digits.

700.36 EXCEPTION TABLE OVERLAY

The ALLOW/DENY tables are organized into two sets of tables to allow the NC-1548 system to support two different departments at one installed site. Allow/Deny Table 1 is referenced whenever a station is assigned Class of Service One and Allow/Deny Table 2 is referenced whenever a station is assigned Class of Service Two (Refer to Figure 7.5. Use Table 7.2 for reference).

The system provides two (2) Allow Tables and two (2) Deny Tables. The Allow Tables may contain up to 10 (eight digit) entries and the Deny Tables may contain up to five (eight digit) entries. Each entry will consist of eight digits or less, including 'Do-Not-Care' characters (asterisk *) and 'Stop' characters (pound sign #).

The system will automatically insert (#) "stop" characters immediately following the last number entered, if vacant digit positions remain. For example, the installer needs only to dial '0' and press the ENTER button to program the eight-digit field, for operator restriction.

Some other rules should be remembered when setting up the Exception Tables.

1. If there are no entries in either the Allow or Deny Table then a number dialed will be allowed.
2. If an entry is made in the Deny Table only, the COS restriction is to 'deny only' the number(s) entered in the Deny Table. Any number not found in the Deny Table will be Allowed.
3. If an entry is made in the Allow Table only, the COS restriction is to 'allow only' those dialed numbers that match the programmed entry in the Allow Table. Any number not found in the Allow will be Denied.
4. If entries are made in both Allow and Deny Tables, the sequence is as follows. Search the Allow Table, if the dialed number is found the call is allowed. If it is not found the Deny Table is searched. If the number dialed is found in the Deny Table, then the dialed number is denied. If the dialed number is not found in the Deny, it is allowed.
5. The Allow One/Deny One and Allow Two/Deny Two Tables are reserved for COS 1 and COS 2, respectively.

ALLOW TABLE	DENY TABLE	CONDITIONS AND RESULTS			
		DIALED NO.	A/D	DIALED NO.	A/D
NO ENTRIES	NO ENTRIES	ALLOW			
ENTRIES	NO ENTRIES	FOUND	A	[Hatched]	
		NOT FOUND	D		
NO ENTRIES	ENTRIES	[Hatched]		FOUND	D
				NOT FOUND	A
ENTRIES	ENTRIES	FOUND	A	[Hatched]	
		NOT FOUND	D		
[Hatched]		ALLOW TABLE		DENY TABLE	

**TABLE 7.2
ALLOW/DENY TOLL TABLE**

700.40 RESIDENT MEMORY

There are three (3) data base areas that are involved in hard restart, customer updating and actual call processing procedures.

1. Default data base area
2. Dynamic data base area
3. Operational data base area

These areas are protected by software and/or hardware write-protect facilities.

700.41 DEFAULT DATA BASE AREA

This area is the system supplied configuration data. All customer modifications are applied to this data (Refer to Figure 7.1 for the default values).

700.42 DYNAMIC DATA BASE AREA

This is the area the customer data base (CDB) update procedures administer. This area is created by copying the operational memory to a dynamic work space when the customer memory update is invoked.

TABLE 7.3
NUMBERING PLAN FOR THE NC-1648

DIAL	DESCRIPTION
0	Abbreviated Dialing to Attendant (Station 10)
6	SLT Zone Pick-Up
9	SLT Line GROUP 1 Access
00-09	Station Speed Access Codes—Preceded with SPEED Button
10-45	System Speed Access Codes—Preceded with SPEED Button
11	Secondary DSS Position
10-57	Station Directory Numbers
70	All Call Page—Internal Zones
71	Internal Page—Zone 1
72	Internal Page—Zone 2
73	Internal Page—Zone 3
74	Internal Page—Zone 4
75	All Call Page—External Zones
76	External Page—Zone 1
77	External Page—Zone 2
78	All Call Page—Internal and External
81	SLT Line Group 2 Access
82	SLT Line Group 3 Access
83	SLT Line Group 4 Access
84	SLT Line Group 5 Access
85	SLT Line Group 6 Access
86	SLT Line Group 7 Access
88	SLT Universal Night Answer Code
*10-45	SLT System Speed Number Selections
#	SLT EX-HOLD Access Code
#	Last Number Redial—Preceded with SPEED button

700.43 OPERATIONAL DATA BASE AREA

This is the area referenced during call processing procedures. This area is under software and hardware write-protect logic.

Part of the hard restart procedure is an attempt to copy the default data base contents into the operational data base area. The contents of the operational data base, after the copy attempt, is dependent upon the state of the write-memory logic. If enabled, it will contain a replica of the default data base; i.e., initial power-up configuration. If disabled, it will contain the previous unique customer data base values.

The write-memory switch is located on the 3 pos DIP switch on the Central Processing Board (CPB), switch 1. This switch should remain off at all times except during Permanent Update Procedures. Refer to Figure 4.2 for the location of this switch.

700.44 NUMBERING PLAN

Refer to Table 7.3 for the numbering plan incorporated within the NC-1648.

700.45 MEMORY BATTERY BACKUP

The NC-1648 utilizes a Lithium battery for memory backup in the event of a commercial AC power failure. The battery has an approximate life of five (5) years. It is located on the CPB.

Optional System Battery Back-up can also be provided to ensure full system operation during power failure with the addition of a 24 volt battery package.

700.46 ON LINE PROGRAMMING

Normal key system operation is virtually unaffected while updating the system memory.

700.50 PROGRAM MODE ENTRY

Entry into the customer data base programming mode is accomplished by depressing the recessed "Data" button on the underside of the primary DSS Console. This action causes all of the LED's to illuminate. The "RELEASE" button should then be depressed five (5) times. This action will extinguish the LED's for approx. five (5) seconds. When the LED's light the second time, overlay selection can commence. If the "RELEASE" button is not pressed five (5) times within ten (10) seconds, the DSS will automatically return to the idle state.

During the programming mode, the primary DSS will no longer function as an attendant console for processing calls. However, the associated key telephone (station 10) will remain operational (Refer to Figure 7.6).

700.51 DSS BUTTON REDEFINITION

Once entrance to the data base programming mode is accomplished, the bottom 2 rows of function buttons are redefined.

The upper row of buttons (Int. Zone 1, Int. zone 2, ... Ext. Zone 2) become Overlay Selection Keys (Station, CO Line, Exception Tables, Speed Dial, Parameters and Update Perm). The bottom row of buttons, (Release, Internal All Call... Night), becomes Function keys (Enter, Initialize and Display.)

The following is a description of the Function buttons involved. Refer to Figures 7.6-7.11 for the location of these buttons. As an example, the Station Overlay (Figure 7.9) is used for reference but these buttons remain constant from overlay to overlay.

1. **ENTER:** The "ENTER" button is used at the end of an overlay attribute sequence. The data is passed through a parameter validation mechanism. Valid data will be moved from the scratch pad working area to the dynamic data base. If valid data has been entered, a steady confirmation tone will be generated when this key is depressed. If the data is invalid, an interrupted tone will be generated.

2. **INIT:** When an overlay is active, the programmer may abort the overlay by invoking the "INIT" function. This action causes the scratchpad memory to be reloaded with the previous memory values and the program may be restarted or another overlay may be selected at this time.

An individual entry may be initialized by invoking the "INIT" function after an "ENTER" function. This initialization will only affect the entry following the last

"ENTER" function. As in any selection, the "ENTER" key must be depressed after invoking the "INIT" function.

3. **DISPLAY PERM:** This function will display the contents of the operational memory on the LED display. If the printer option is installed, the information will be displayed and printed. This function will print an entry, if one has been selected, and print an overlay, if an entry has not been selected. The LED's will not display in overlay mode.

4. **UPDATE:** The "UPDATE PERM" key will act as a prime for transferring the dynamic memory to the operational data base. The dynamic memory will be transferred to the operational data base when the following conditions have been satisfied:

1. Validation requirements have been met.
2. The data mode was entered.
3. The Update Perm key was the last function involved prior to leaving the data mode.
4. Write memory switch was turned on.
5. The Data Entry button, recessed on the underside of the DSS, is depressed.

5. **DISPLAY MODE:** This LED is lit whenever a display mode is active. The depression of this button will reset the display mode.

6. **DUPE:** The "DUPE" button may be used to transfer the last entry to the currently selected entry. If no data has been entered then this function will not be performed. The "ENTER" or "NEXT" function must be invoked to store the "DUPE" (duplicate) information.

7. **NEXT:** The depression of this key will cause the currently selected station, or CO Line to be incremented by one. If no entry is currently selected, or the highest entry number is selected, then the lowest station number is selected.

8. **STATION NUM:** This function will display the station number of the current entry on the key pad. The ten's digit will be displayed as a steady lamp. The units digit will be displayed as a flashing lamp. If only a steady lamp is displayed, then the entry has the same digit for the ten's and unit positions.

700.52 PROGRAMMING OVERLAYS

700.61 OVERLAY MODE ENTRY

The entrance to the overlay mode is made by depressing the Station, CO Line, Exception, System Speed, or System Parameter button. Once an overlay has been selected, its respective LED will remain lit until

another overlay is selected. No information is transferred to dynamic memory until the Enter-Key is depressed and the Data validation has been performed.

Data that has passed validation will respond with a long tone and erroneous data will be indicated with an error tone from the DSS.

The following pages give step by step instructions for programming each overlay. Examples of the overlays, Figures 7.6 through 7.11 are also included for reference purposes.

700.62 SYSTEM PARAMETERS DATA BASE ENTRY

The following steps should be followed when programming the System Parameters (Refer to Figure 7.7).

All default attributes will be illuminated upon entry to this programming mode. In the case of yes/no values, continued depression of the applicable button will cause the LED to toggle between on and off. Where numeric data is required, exceeding the variable limits of individual parameters will cause error tone to be generated when the 'Enter' button is depressed. All system timers can be effectively deactivated by entering all zeros for the associated timer value.

- A. Place the System Parameters Overlay on the DSS Console.
- B. Depress the SYSTEM PARAMETERS attribute button.
- C. Select desired parameter button.

SELECTIONS

1. **Exclusive Hold Recall:** This entry reflects the time elapsed before a call placed on exclusive hold will recall the station activating this feature. If unanswered for the same elapsed time this call will then ring the attendant. The default value is set at 060 seconds and is variable from 001 to 255 seconds. The entry format requires three (3) digits.

2. **Transfer Recall:** This entry reflects the time elapsed before an unanswered call transfer is recalled to the station that initiated the transfer. If unanswered for the same elapsed time this call will then ring the attendant. The default value is set at 060 seconds and is variable from 001 to 255 seconds. The entry format requires three (3) digits.

3. **System Hold Recall:** This entry reflects the time elapsed before an unanswered system hold is recalled

to the station that initiated the system hold. If unanswered for the same elapsed time this call will then ring the attendant. The default value is set at 600 seconds and is variable from 001 to 600 seconds. The entry format requires three (3) digits.

4. **Flash Timer:** This timer reflects the duration of a simulated hookswitch flash. This feature has particular applications when the 1648 is interfaced with an EPABX. The default value is 2 seconds. Two digit entries are made allowing increments of 1/10 of a second (i.e. 15 equals 1.5 seconds). References to the min/max values of the associated EPABX should be made when setting this timer.

5. **Paging Time-Out:** This timer determines the amount of time all paging circuits will stay seized. This includes both internal and external zones. When setting this timer, the maximum length of a page should be considered. The default value is set at 60 seconds and is variable from 01-99 seconds.

6. **Conference Timeout:** This timer reflects the amount of time the conference circuit will remain active if the initiator of the conference is no longer in the circuit. A warning tone will be presented to the remaining users 15 seconds prior to shutdown. The default value is set at 090 minutes and is variable between 001-090 minutes. The entry format requires a three-digit entry. The timeout clock is automatically reset to zero whenever the conference initiator re-enters the conference.

7. **Executive/Secretary:** Four Executive/Secretary pairs are available for programming, consisting of two-key telephones or SLT's in each pair. When the executive is in Do-Not-Disturb or busy, all calls will be re-routed to the assigned secretary (ies). Stations may be assigned to more than one pair. In such cases, the calls are routed by order of entry until an available station is idle. If all stations are busy, the call is routed back to the first station for busy verification. If this station is still busy, busy tone will be encountered at which time the override feature may be invoked if allowed.

8. **System Time:** This entry allows the setting of the system clock. The internal clock is referenced when the diagnostic start time is initiated. The entry format requires a four (4) digit entry (i.e. HHMM, where HH=hours and MM=minutes). The time should be entered in a 24-hour format.

9. **Diagnostic Start Time:** This entry is the actual time (24-hour format) that on-line diagnostics will begin. The default value is set at 2525 hours. This invalid time effectively disables on-line diagnostics. Any defects

encountered during the diagnostic routines will extinguish the associated monitor LED on the CPB.

10. External Night Ring: This parameter when set at 'YES' activates the external night ring feature. When the trunk UNA feature is also set to 'YES', tone will be output to both paging ports when a CO line receives an incoming call.

11. Attendant Override: This parameter when set at 'YES' activates the attendant override feature, allowing DND override tone and CO LINE delayed station barge-in.

12. System Date: Enter the correct date in YY/MM/DD format where YY=current year, MM=current month, and DD=current day.

13. Loud Bell Control: Setting this parameter to 'YES' and setting the individual CO Line 'UNA' to 'YES' allows external bell control in both day and night mode for that CO line. Setting this parameter to 'NO' and setting the individual trunk 'UNA' to 'YES' allows external bell control in the night only mode. When connected, the LBC contact closure will provide an interrupted sequence of one second on (closed) and four seconds off (open) until all lines are answered.

14. Baud Rate Select: This parameter controls the baud rate for the printer output. F=Fast or 1200 baud. S=Slow or 300 baud. The default setting for this parameter is 300 baud. This is indicated by the appropriate LED in the 'ON' mode. The LED should be OFF (1200 Baud) for proper mini-printer operation.

SELECTION ENTRY

- D. Enter the selected timer value if required or activate the desired feature via the Overlay keypad. Refer to the Customer Data Base Sheets for the correct programming format.
- E. Depress the ENTER button. Validation tone should be heard. If error tone is encountered, repeat process from item C.
- F. To continue, repeat process from item C.
- G. To validate all entries, depress the desired parameter button and DISPLAY TEMP and the contents of the scratchpad memory for that overlay will be printed on an external device or displayed on the DSS through the display procedure.
- H. When all entries have been entered/displayed select the next overlay or refer to Permanent Update Procedures.

700.93 CO LINE DATA BASE ENTRY

The following steps should be followed when programming CO/PBX lines. Refer to the Customer Data Base Sheets and Figure 7.8 for the correct programming information.

All default attributes will be illuminated upon entry to this programming mode. In the case of yes/no values, continued depression of the applicable button will cause the LED to toggle between on and off. In the case of multiple choice selections, a new entry will cause the LED of the previous value to extinguish.

- A. Place the CO Line Overlay on the DSS Console.
- B. Depress the CO LINE ATTRIBUTE button.
- C. Depress the desired CO LINE button.
- D. Depress the desired CO LINE GROUP button. A CO/PBX line can be assigned to one (1) CO Line Group only.
- E. Depress either 1 or 2 digit PBX DIALING, if required.
- F. Depress TOLL RESTRICTION OVERRIDE, if required. This feature defaults to NO, therefore, a button depression will allow this feature.
- G. Depress UNA if not required. The default value is yes and LED is 'ON'.
- H. Depress STATION RING (DAY) if required. Enter desired key station numbers for day mode operation. All entries should be made concurrently (i.e. enter 1011213 to program stations 10, 11, 12, and 13 to ring during the day. Stations assigned for day ringing will also ring at night (Max 8 stations per CO line). Station 10 is preassigned (default) as one of the 8 stations maximum. If an additional entry is required, Station 10 must be reentered if it is to be day ring station.
- I. Depress ENTER button. Validation tone should be heard when button is depressed. If error tone is encountered, repeat process.
- J. Depress STATION RING (NIGHT) if required. Enter desired key station numbers for night mode operation. Remember that those stations assigned for day mode will ring at night automatically. Stations assigned with this function will only ring at night (Max 5 night ring stations per CO line).
- K. Depress ENTER button. Validation tone should be heard when button is depressed. If error tone is encountered, repeat process.
- L. To program additional CO lines go to item C and

repeat. If an error is made during program entry return to invalid item and re-enter.

- M. To validate all entries, depress DISP TEMP and the contents of the scratchpad memory for that overlay will be printed on an external device or displayed on the DSS through the display procedure.
- N. When all CO lines have been entered/displayed, select the next overlay or refer to Permanent Update Procedures.

700.64 STATION LINE DATA BASE ENTRY

The following steps should be followed when programming station lines. Refer to the Customer Data Base Sheets and Figure 7.9 for the correct programming information.

- A. Place the Station Lines Overlay on the DSS Console.
- B. Depress the STATION ATTRIBUTE button.
- C. Depress the STATION NUM button.
- D. Enter the desired station number via the DSS keypad. Upon entry, the ten's digit will be lit steady and the units digit will flash to signify which station is being programmed. If only a steady light is visible, both digits are identical.
- E. Depress the appropriate CLASS button.
- F. Depress the PAGE/PICK UP ZONE address buttons. A station user can be in more than one zone address. Subsequent depression of these buttons will have a toggle effect and will allow/deny paging announcements on a particular zone. The pick-up groups will be designated according to the assignments selected.
- G. Depress the accessible CO LINE GROUP button. A station user can have access to any variety of CO Line Groups. Subsequent depression of these buttons will have a toggle effect and will allow/deny access to a particular group. If the station was assigned to ring for a particular CO line in the CO Overlay Program, this station must be assigned access to the associated CO Line Group in order to answer the ringing line during day mode operation. Refer to 'UNA' for night mode operation.
- H. Depress the SYSTEM SPEED button if access to system speed is not allowed. Since the default value for this feature is ALLOW, the LED will be illuminated upon entry to this mode for the station being programmed. Therefore, a depression of this button will extinguish this LED thus denying this feature. Further depression will cause the LED to

toggle between on and off.

- I. Depress the DND button if this feature is not desired. Since the default value for this feature is ALLOW, the LED will be illuminated upon entry to this mode for the station being programmed. Therefore, a depression of this button will extinguish the LED, thus denying this feature. Further depression will cause the LED to toggle between on and off.
- J. Depress the ENTER button.
- K. If further stations are to be programmed, and sequential mode is desired, press the NEXT button and continue from item E. If individual entry is required go back to item C.
- L. To validate all entries, depress DISP TEMP and the contents of the scratchpad memory will be displayed.
- M. When all Station Lines have been entered/displayed, select the next overlay or refer to Permanent Update procedures.

700.65 SYSTEM SPEED DIAL DATA BASE ENTRY

The following steps should be followed when programming system speed dial entries. Refer to the Customer Data Base Sheets and Figure 7.10 for the correct programming information entering.

- A. Place the System Speed Dial Overlay on the DSS Console.
- B. Depress the SYSTEM SPEED DIAL Attribute button.
- C. Depress the desired BIN location (Sins 10-45).
- D. Enter the required telephone number via the DSS keypad. A pound (#) should be used whenever a pause is required. A maximum of 24 digits including pauses are available. If this maximum is exceeded, error tone will be generated upon entry of the excess digit.
- E. Depress ENTER button. Validation tone should be heard when button is depressed. If error tone is encountered, repeat process.
- F. To program additional speed dial bin locations, repeat process from item C.
- G. To validate all entries, depress DISP TEMP and the contents of the scratchpad memory will be displayed.
- H. When all Speed Dial locations have been entered/displayed, select the next overlay or refer to Permanent Update Procedures.

700.66 EXCEPTION TABLE DATA BASE ENTRY

The following steps should be followed when programming Exception Table entries. Refer to the Customer Data Base Sheets and Figure 7.11 for correct programming information.

- A. Place the Exception Table Overlay on the DSS Console.
- B. Depress the EXCEPT TABLE Attribute button.
- C. Depress the required ALLOW/DENY bin location. For the associated Class-of-Service (COS), COS 1 is assigned to Allow/Deny Table 1 and COS 2 is assigned to Allow/Deny Table 2.
- D. Enter the required digits via the DSS keypad.
- E. Depress the ENTER button. Validation tone should be heard. If error tone is received, repeat process from item C.
- F. To program additional Allow/Deny numbers go to item C and repeat process.
- G. To validate all entries, depress DISP TEMP and the contents of the scratchpad memory for that overlay will be printed on an external device or displayed on the DSS through the display procedure.
- H. When all Allow/Deny numbers have been entered/ displayed, select another overlay or refer to Permanent Update Procedures.

700.70 PERMANENT UPDATE PROCEDURES

The following procedures should be followed to permanently store all data base entries into memory. Close attention should be followed to eliminate the possibility of error.

- A. Depress the UPDATE PERM button on the DSS Console.
- B. Set DIP switch, POS 1, on CPB PCB to ON.
- C. Depress program switch on underside of DSS Console.
- D. Set DIP switch, POS 1, on CPB PCB to OFF.

Customer data has now been stored, and protected. The DSS Console has been restored to normal service.

700.80 DISPLAY PROCEDURES

The NC-1648 provides through either the RS-232C connector or by DSS button illumination a status of the temporary and permanent data base. The following is a detailed procedure for obtaining this information.

700.81 RS-232C HARDCOPY PRINTOUT

In order to obtain a hard copy printout of the present database, a compatible listing device must be connected to the RS-232C connector. Optionally, the NC-1648 Mini-Printer may be utilized for data base print-out. Refer to Figure 5.17 for proper cabling connections for this device. If the programming mode is currently active, proceed with the following instructions. Otherwise, follow the procedures previously outlined for program mode entry.

When the programming mode has been entered and the desired overlay has been selected, depress 'DISP PERM'. The entire data base contents for the selected overlay will then be displayed on the listing device. Changes made prior to the 'UPDATE PERM' procedure can be displayed by depressing the 'DISP TEMP' button. This latter procedure will insure that the changes were made correctly prior to permanent update.

Figure 7.12 through 7.17 are examples of a typical system database print-out.

700.82 DATA BASE DISPLAY WITHOUT A LISTING DEVICE

In addition to using an RS-232C device, the temporary and permanent data bases can be displayed by observing the status of the LED's on the DSS Console.

Upon entry to the particular overlay, permanent data is duplicated in the temporary area. Therefore, when a unique overlay and attribute is selected, the contents of the temporary data base will match that data in the permanent data base. Only when data base changes have been made, prior to a permanent update, will the two differ.

Following the above-mentioned procedures for data mode entry, select the desired overlay mode. Because each overlay displays differently, each is outlined below.

700.821 SYSTEM PARAMETERS OVERLAY DISPLAY

1. Depress PARAM ATTRIB button
2. Depress desired timer button.
3. Depress either DISP TEMP or DISP PERM button. (The mode button will light.) The first digit of the timer value will be displayed on the appropriate dial LED.
4. For subsequent digits, continue to depress the timer button and observe which led's light. When all digits have been displayed, continued depression will result in error tone, signifying that all digits have been

displayed.

5. To display other parameters, continue process from item 2.
6. When all parameters have been displayed, continue with display or initiate change or exit procedures.

700.822 CO LINE OVERLAY DISPLAY

1. Depress the CO ATTRIBUTE button.
2. Depress the desired CO line button. All attributes for the selected line will be displayed, except ring assignments. Ring assignments are displayed as follows:
 - a) Depress the Day/Night ring button.
 - b) Depress Temp/Perm display button. The first digit of the first assigned station will display on the key pad.
 - c) Subsequent depressions of the Day/Night button will display the remaining digits.
3. If desired, the NEXT button can be depressed and the next CO Line will be displayed. Otherwise, select the next desired CO Line and it will be displayed.
4. When all CO Line have been displayed, continue with display or refer to change or exit procedures.

700.823 STATION OVERLAY DISPLAY

1. Depress the Station Attribute button.
2. Depress the Sta. Num button.
3. Dial selected station number on DSS Dial Pad. The Tens digit will light steady and the units digit will flash for the selected station number. Associated data for the selected station will illuminate for any attributes assigned. These data are the permanent data. If changes have been made prior to permanent update, that information can be displayed for the selected station by depressing the DISP TEMP button.
4. To select the next station number in sequence, depress the NEXT button. If the next sequential station is not desired, enter the next station number desired on the DSS Dial Pad.
5. When all desired stations have been displayed, continue with display or refer to change or exit procedures.

700.824 SPEED DIAL OVERLAY DISPLAY

1. Depress the SPEED DIAL attribute button.
2. Depress the selected bin location (10-45).
3. Depress the DISP TEMP button.
The first digit of the entered speed dial number will be illuminated on the DSS Dial Pad. Prior to new programming, DISP TEMP button allows viewing of PERM data.
4. Depress the selected bin location again. The second digit of the entered speed dial number will now illuminate. Continued depression of the bin location button will illuminate the subsequent digits of the entered speed dial number.
5. To display other bin locations, repeat the above process from item 1.
6. When all desired bin locations have been displayed, continue with display procedures or refer to change or exit procedures.

700.825 EXCEPTION TABLE OVERLAY DISPLAY

1. Depress the EXCEPT attribute button.
2. Depress the desired exception table bin location.
3. Depress the DISP TEMP button.
The first digit in the selected bin location is displayed on the DSS key pad.
4. Depress the selected exception table bin location again. The second digit will then display on the DSS dial pad. Continued depressions will display subsequent digits. When all digits have been displayed, continued button depression will result in error tone, indicating that all digits have been displayed.
5. When all desired bin locations have been displayed, continue with display procedures or refer to change or exit procedures.

PARAMETER	FORMAT	DEFAULT	NEW VALUE
EXCLUSIVE HOLD RECALL	000-255 SEC	050 SEC	
TRANSFER RECALL	000-255 SEC	050 SEC	
SYSTEM HOLD RECALL	000-500 SEC	600 SEC	
FLASH TIMER	0.1-9.9 SEC	2.0 SEC	
PAGING TIME-OUT	01-99 SEC	60 SEC	
CONFERENCE TIME-OUT	001-090 MIN	090 MIN	
EXECUTIVE/SECRETARY 1	STA#/STA#	00/00	
EXECUTIVE/SECRETARY 2	STA#/STA#	00/00	
EXECUTIVE/SECRETARY 3	STA#/STA#	00/00	
EXECUTIVE/SECRETARY 4	STA#/STA#	00/00	
SYSTEM TIME	HHMM	0000	
DIAGNOSTIC START TIME	0000-2359	2525	
EXTERNAL NIGHT RING	Y/N	N	
ATTENDANT OVERRIDE	Y/N	N	
SYSTEM DATE	YY/MM/DD	84/01/01	
LOUD BELL CONTROL	D/N (DAY/NIGHT)	N	
BAUD RATE SELECT	S/F (300/1200)	S (300)	

FIGURE 7.1
CUSTOMER DEFINITION SHEET
(SYSTEM PARAMETERS OVERLAY)

TRUNK #	GROUP (0-7)	PEX DIALING		TOLL REST. OVRD (Y/N)	UNA (Y/N)	DAY RING STATION # (S MAX)	NIGHT RING STATION # (S MAX)	REMARKS
		1 DIGIT (Y/N)	2 DIGIT (Y/N)					
CO 01								
CO 02								
CO 03								
CO 04								
CO 05								
CO 06								
CO 07								
CO 08								
CO 09								
CO 10								
CO 11								
CO 12								
CO 13								
CO 14								
CO 15								
CO 16								

NOTES:

1. A CO/PSX LINE MAY ONLY BE IN ONE CO LINE GROUP.
2. A CO LINE ASSIGNED TO RING STATIONS DURING THE DAY WILL ALSO RING THOSE STATIONS AT NIGHT. THIS HAS NO BEARING ON THE MAXIMUM NUMBER OF NIGHT RINGING STATION AVAILABLE.

FIGURE 7.2
 CUSTOMER DEFINITION SHEET
 (CO LINE OVERLAY)

STATION #	COS 0-5	PAGE ZONE 1,2,3,4,0	LINE GROUP 1,2,3,4,5,6,7	DND Y/N	SYS-SPEED Y/N	REMARKS
10						
11						
12						
13						
14						
15						
16						
17						
18						
19						
20						
21						
22						
23						
24						
25						
26						
27						
28						
29						
30						
31						
32						
33						
34						
35						
36						
37						
38						
39						
40						
41						
42						
43						
44						
45						
46						
47						
48						
49						
50						
51						
52						
53						
54						
55						
56						
57						

FIGURE 7.3
 CUSTOMER DEFINITION SHEET
 (STATION OVERLAY)

BIN #	TELEPHONE NUMBER (MAX 24 DIGITS INCLUDING PAUSES)
10	
11	
12	
13	
14	
15	
16	
17	
18	
19	
20	
21	
22	
23	
24	
25	
26	
27	
28	
29	
30	
31	
32	
33	
34	
35	
36	
37	
38	
39	
40	
41	
42	
43	
44	
45	

FIGURE 7.4
CUSTOMER DEFINITION SHEET
(SPEED DIAL OVERLAY)

TABLE #	BIN #	NUMBER TO ALLOW/DENY (8 DIGITS MAX)
ALLOW 1	1	
ALLOW 1	2	
ALLOW 1	3	
ALLOW 1	4	
ALLOW 1	5	
ALLOW 1	6	
ALLOW 1	7	
ALLOW 1	8	
ALLOW 1	9	
ALLOW 1	10	
DENY 1	1	
DENY 1	2	
DENY 1	3	
DENY 1	4	
DENY 1	5	
ALLOW 2	1	
ALLOW 2	2	
ALLOW 2	3	
ALLOW 2	4	
ALLOW 2	5	
ALLOW 2	6	
ALLOW 2	7	
ALLOW 2	8	
ALLOW 2	9	
ALLOW 2	10	
DENY 2	1	
DENY 2	2	
DENY 2	3	
DENY 2	4	
DENY 2	5	

FIGURE 7.5
 CUSTOMER DEFINITION SHEET
 (EXCEPTION TABLE OVERLAY)

Program Mode entry:

1. Depress data switch on under side of DSS console.
2. Depress RELEASE button five (5) times.
3. When all LED's light, select appropriate overlay parameter button and commence programming.

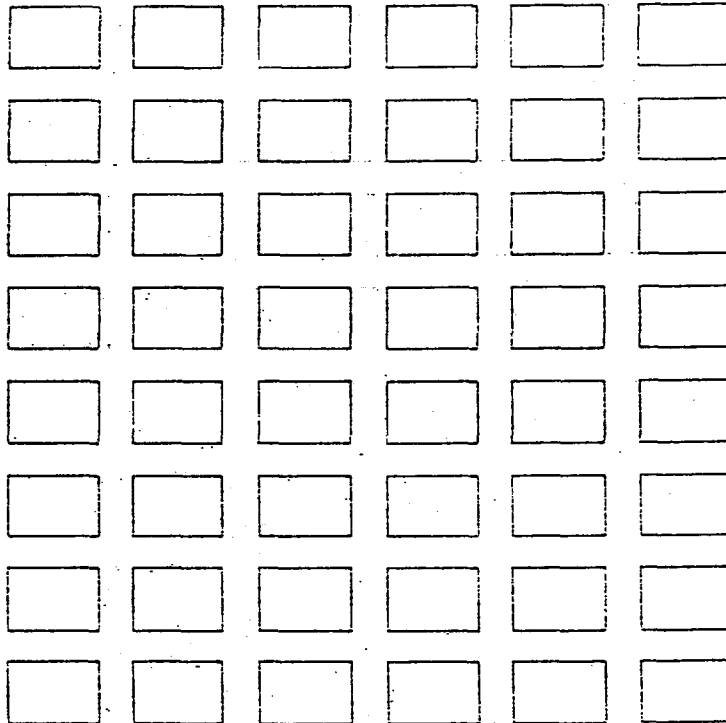

Program-Mode Exit:

1. Depress UPDATE PERM. button on the DSS console.
2. Operate switch on CPB to "ON".
3. Depress data switch on under side of DSS console.
4. Operate switch on CPB to "OFF".

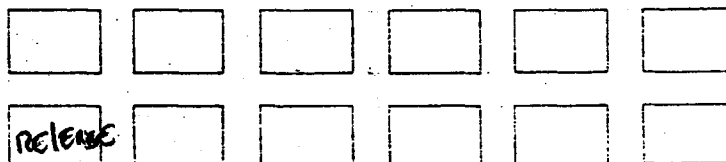

5x PROGRAM entry.

FIGURE 7.6
INSTRUCTION OVERLAY

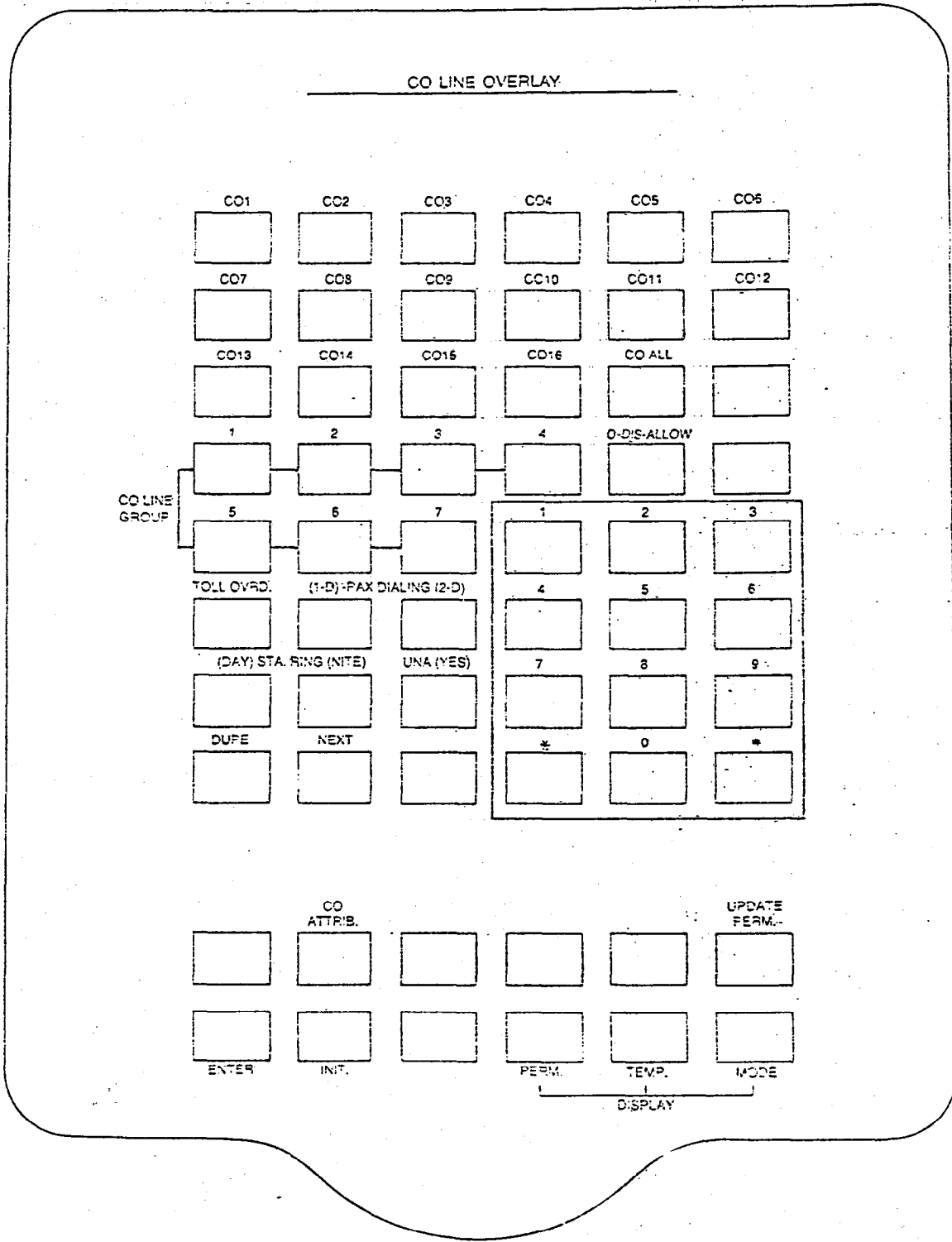

**FIGURE 7.8
CO LINE OVERLAY**

STATION OVERLAY

	0	1	2	3	4	5																														
CLASS OF SERVICE	<input type="text"/>	<input type="text"/>	<input type="text"/>	<input type="text"/>	<input type="text"/>	<input type="text"/>																														
	IZ-1	IZ-2	IZ-3	IZ-4																																
PAGE/PICKUP ZONE(S)	<input type="text"/>	<input type="text"/>	<input type="text"/>	<input type="text"/>	<input type="text"/>	<input type="text"/>																														
	1	2	3	4																																
COLINE GROUP	<input type="text"/>	<input type="text"/>	<input type="text"/>	<input type="text"/>	<input type="text"/>	<input type="text"/>																														
	5	6	7																																	
	<input type="text"/>	<input type="text"/>	<input type="text"/>	<input type="text"/>	<input type="text"/>	<input type="text"/>																														
SYS. SPD. (YES)	<input type="text"/>	DND (YES)	<input type="text"/>	<table border="1"> <tr> <td>1</td> <td>2</td> <td>3</td> </tr> <tr> <td><input type="text"/></td> <td><input type="text"/></td> <td><input type="text"/></td> </tr> <tr> <td>4</td> <td>5</td> <td>6</td> </tr> <tr> <td><input type="text"/></td> <td><input type="text"/></td> <td><input type="text"/></td> </tr> <tr> <td>7</td> <td>8</td> <td>9</td> </tr> <tr> <td><input type="text"/></td> <td><input type="text"/></td> <td><input type="text"/></td> </tr> <tr> <td>DUPE</td> <td>NEXT</td> <td>STA. NUM.</td> <td>*</td> <td>0</td> <td>*</td> </tr> <tr> <td><input type="text"/></td> <td><input type="text"/></td> <td><input type="text"/></td> <td><input type="text"/></td> <td><input type="text"/></td> <td><input type="text"/></td> </tr> </table>			1	2	3	<input type="text"/>	<input type="text"/>	<input type="text"/>	4	5	6	<input type="text"/>	<input type="text"/>	<input type="text"/>	7	8	9	<input type="text"/>	<input type="text"/>	<input type="text"/>	DUPE	NEXT	STA. NUM.	*	0	*	<input type="text"/>	<input type="text"/>	<input type="text"/>	<input type="text"/>	<input type="text"/>	<input type="text"/>
1	2	3																																		
<input type="text"/>	<input type="text"/>	<input type="text"/>																																		
4	5	6																																		
<input type="text"/>	<input type="text"/>	<input type="text"/>																																		
7	8	9																																		
<input type="text"/>	<input type="text"/>	<input type="text"/>																																		
DUPE	NEXT	STA. NUM.	*	0	*																															
<input type="text"/>	<input type="text"/>	<input type="text"/>	<input type="text"/>	<input type="text"/>	<input type="text"/>																															
	<input type="text"/>	<input type="text"/>	<input type="text"/>																																	
	<input type="text"/>	<input type="text"/>	<input type="text"/>																																	
	<input type="text"/>	<input type="text"/>	<input type="text"/>																																	
	<input type="text"/>	<input type="text"/>	<input type="text"/>																																	
STA. ATTRIB.	<input type="text"/>	<input type="text"/>	<input type="text"/>	<input type="text"/>	<input type="text"/>	UPDATE PERM.																														
	<input type="text"/>	<input type="text"/>	<input type="text"/>	<input type="text"/>	<input type="text"/>	<input type="text"/>																														
ENTER	INIT.		PERM.	TEMP.	MODE																															
			DISPLAY																																	

FIGURE 7.9
STATION OVERLAY

SYSTEM SPEED DIAL OVERLAY

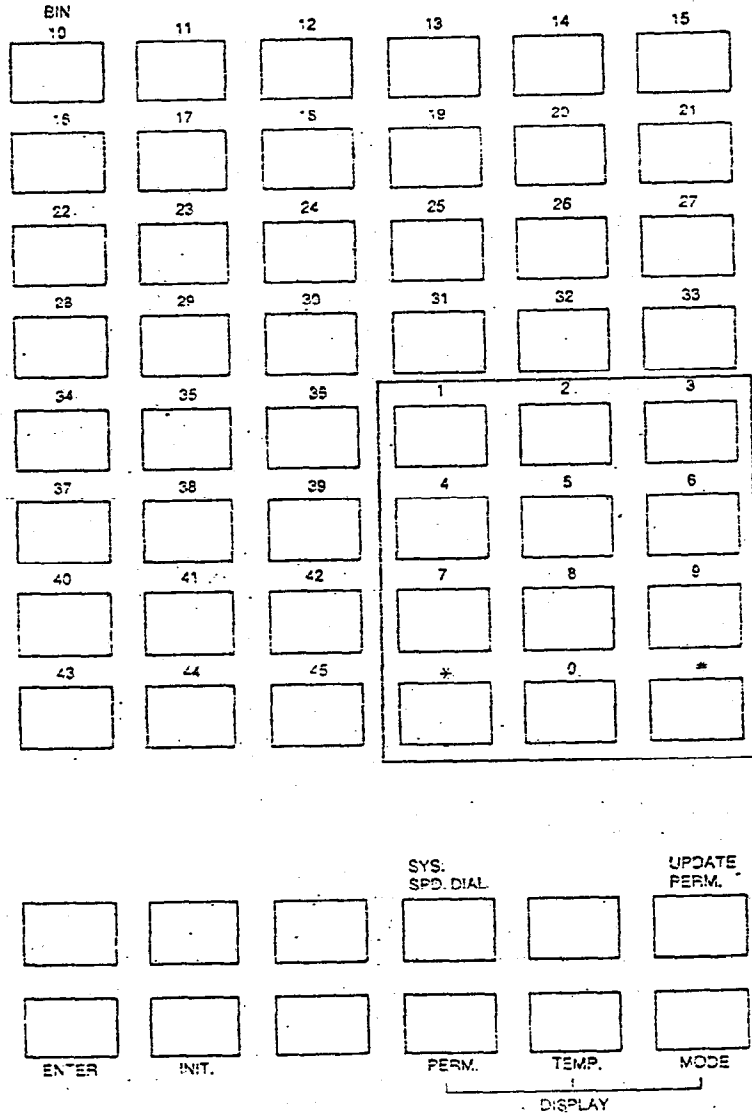

FIGURE 7.10
SYSTEM SPEED DIAL OVERLAY

EXCEPTION TABLES OVERLAY

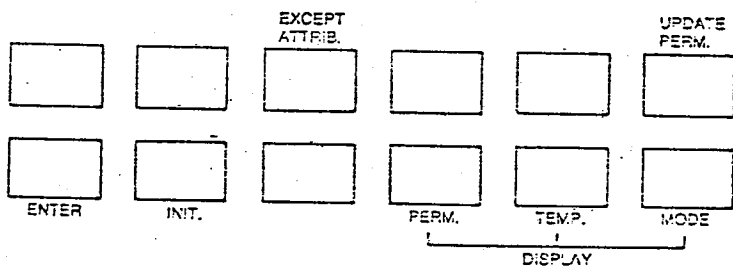
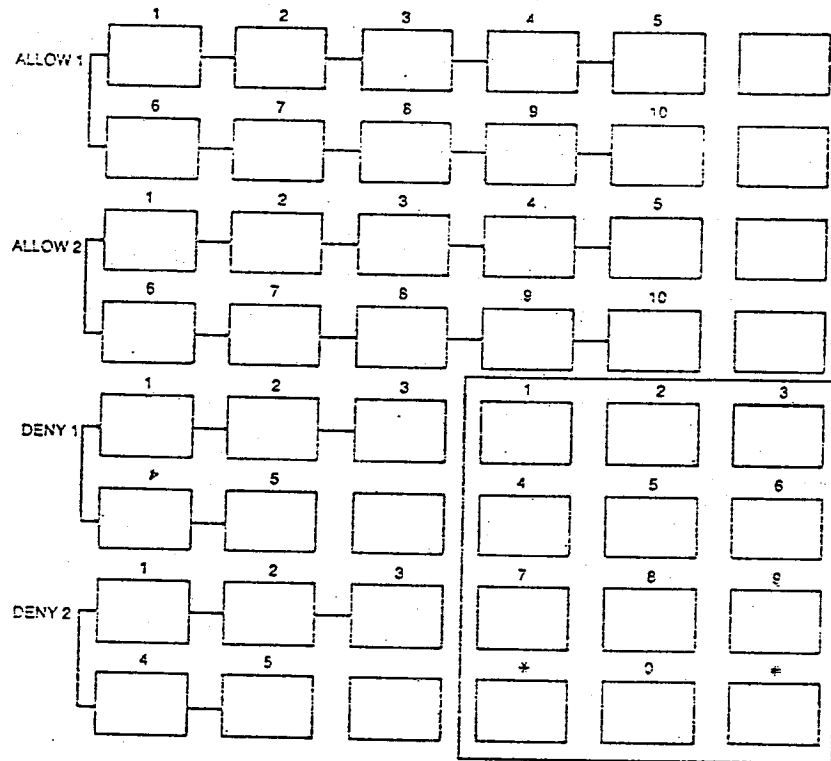

FIGURE 7.11
EXCEPTION TABLES OVERLAY

SYSTEM PARAMETERS

ERCL	TRCL	SRCL	FLSH	PGTO	CONF
020	020	020	02	20	002
BS/SY1	BS/SY2	BS/SY3	BS/SY4		
26 27	25 27	00 00	00 00		
DIAG START TIME			SYSTEM TIME		
25:25			01:17		
ENR	ATO	LBC	BSL	SYSTEM DATE	
Y	Y	D	F	84/06/07	

FIGURE 7.12
SYSTEM PARAMETERS RECORD

COLINE STATUS

CO	NUM	GROUP	TRO	PBX	UNA	CO	NUM	GROUP	TRO	PBX	UNA
01		1	N	O	Y	09		1	N	O	Y
		DAY RING						DAY RING			
		10	00	00	00	00	00	00	00	00	00
		NIGHT RING						NIGHT RING			
		00	00	00	00	00	00	00	00	00	00
02		1	N	O	Y	10		2	Y	1	N
		DAY RING						DAY RING			
		11	12	13	00	00	00	00	00	00	00
		NIGHT RING						NIGHT RING			
		13	14	00	00	00	00	00	00	00	00
03		1	N	O	Y	11		2	Y	1	N
		DAY RING						DAY RING			
		10	00	00	00	00	00	00	00	00	00
		NIGHT RING						NIGHT RING			
		00	00	00	00	00	00	00	00	00	00
04		1	N	O	Y	12		0	N	O	N
		DAY RING						DAY RING			
		10	00	00	00	00	00	00	00	00	00
		NIGHT RING						NIGHT RING			
		00	00	00	00	00	00	00	00	00	00
05		1	N	O	Y	13		0	N	O	N
		DAY RING						DAY RING			
		10	00	00	00	00	00	00	00	00	00
		NIGHT RING						NIGHT RING			
		00	00	00	00	00	00	00	00	00	00
06		1	N	O	Y	14		0	N	O	N
		DAY RING						DAY RING			
		10	00	00	00	00	00	00	00	00	00
		NIGHT RING						NIGHT RING			
		00	00	00	00	00	00	00	00	00	00
07		1	N	O	Y	15		0	N	O	N
		DAY RING						DAY RING			
		10	00	00	00	00	00	00	00	00	00
		NIGHT RING						NIGHT RING			
		00	00	00	00	00	00	00	00	00	00
08		1	N	O	Y	16		0	N	O	N
		DAY RING						DAY RING			
		10	00	00	00	00	00	00	00	00	00
		NIGHT RING						NIGHT RING			
		00	00	00	00	00	00	00	00	00	00

FIGURE 7.13
CO-LINE RECORD

NUM	COS	CO GROUP	ZNE	SPD	DND
10	0	1	1	Y	Y
11	0	1	1	Y	Y
12	0	1	1	Y	Y
13	0	1	1	Y	Y
14	0	1	1	Y	Y
15	0	1	1	Y	Y
16	0	1	1	Y	Y
17	0	1	1	Y	Y
18	0	1	1	Y	Y
19	0	1	1	Y	Y
20	0	1	1	Y	Y
21	0	1	1	Y	Y
22	0	1	1	Y	Y
23	0	1	1	Y	Y
24	0	1	1	Y	Y
25	0	1	1	Y	Y
26	0	1	1	Y	Y
27	0	1	1	Y	Y
28	0	1	1	Y	Y
29	0	1	1	Y	Y
30	0	12	12	Y	Y
31	0	12	12	Y	Y
32	0	12	12	Y	Y
33	0	12	12	Y	Y
34	0	12	12	Y	Y
35	0	12	12	Y	Y
36	0	12	12	Y	Y
37	0	1	1	Y	Y
38	0	1	1	Y	Y
39	0	1	1	Y	Y
40	0	1	1	Y	Y
41	0	1	1	Y	Y
42	0	1	1	Y	Y
43	0	1	1	Y	Y
44	0	1	1	Y	Y
45	0	1	1	Y	Y
46	0	1	1	Y	Y
47	0	1	1	Y	Y
48	0	1	1	Y	Y
49	0	1	1	Y	Y
50	0	1	1	Y	Y
51	0	1	1	Y	Y
52	0	1	1	Y	Y
53	0	1	1	Y	Y
54	0	1	1	Y	Y
55	0	1	1	Y	Y
56	0	1	1	Y	Y
57	0	1	1	Y	Y

FIGURE 7. 14
STATION RECORD

ALLOW TABLE 1

ENTRY NUMBER

01	1	8	0	0	#	#	#	#
02	1	3	0	5	#	#	#	#
03	#	#	#	#	#	#	#	#
04	#	#	#	#	#	#	#	#
05	#	#	#	#	#	#	#	#
06	#	#	#	#	#	#	#	#
07	#	#	#	#	#	#	#	#
08	#	#	#	#	#	#	#	#
09	#	#	#	#	#	#	#	#
10	#	#	#	#	#	#	#	#

ALLOW TABLE 2

ENTRY NUMBER

01	#	#	#	#	#	#	#	#
02	#	#	#	#	#	#	#	#
03	#	#	#	#	#	#	#	#
04	#	#	#	#	#	#	#	#
05	#	#	#	#	#	#	#	#
06	#	#	#	#	#	#	#	#
07	#	#	#	#	#	#	#	#
08	#	#	#	#	#	#	#	#
09	#	#	#	#	#	#	#	#
10	#	#	#	#	#	#	#	#

DENY TABLE 1

ENTRY NUMBER

01	1	#	#	#	#	#	#	#
02	0	#	#	#	#	#	#	#
03	#	#	#	#	#	#	#	#
04	#	#	#	#	#	#	#	#
05	#	#	#	#	#	#	#	#

DENY TABLE 2

ENTRY NUMBER

01	#	#	#	#	#	#	#	#
02	#	#	#	#	#	#	#	#
03	#	#	#	#	#	#	#	#
04	#	#	#	#	#	#	#	#
05	#	#	#	#	#	#	#	#

FIGURE 7.15
EXCEPTION TABLE

ENTRY NUMBER

10	555121200000000000000000
11	000000000000000000000000
12	000000000000000000000000
13	000000000000000000000000
14	000000000000000000000000
15	000000000000000000000000
16	000000000000000000000000
17	000000000000000000000000
18	000000000000000000000000
19	000000000000000000000000
20	000000000000000000000000
21	000000000000000000000000
22	000000000000000000000000
23	000000000000000000000000
24	000000000000000000000000
25	000000000000000000000000
26	000000000000000000000000
27	000000000000000000000000
28	000000000000000000000000
29	000000000000000000000000
30	000000000000000000000000
31	000000000000000000000000
32	000000000000000000000000
33	000000000000000000000000
34	000000000000000000000000
35	000000000000000000000000
36	000000000000000000000000
37	000000000000000000000000
38	000000000000000000000000
39	000000000000000000000000
40	000000000000000000000000
41	000000000000000000000000
42	000000000000000000000000
43	000000000000000000000000
44	000000000000000000000000
45	000000000000000000000000

FIGURE 7.16
SYSTEM SPEED RECORD

800 OPERATIONAL TESTS
800.10 POWER SUPPLY TESTS

The NC-1643 DC/DC Converter is pre-set at the time of manufacturing, but should be checked at system initialization with a digital volt meter having an accuracy of $\pm 1\%$.			
DC/DC Converter			
Voltage Type	Voltage Reading	Test Point Location	Remarks
+5 VDC	$+5V \pm 1\%$	Front of DC/DC Converter	Adjustable on front cover of DC/DC Converter.
-5 VDC	$-5V \pm 4\%$	Front of DC/DC Converter	—
+24 VDC	$+24V \pm 5\%$	Front of DC/DC Converter	If 24V is below 22V or above 29V, check AC power for $117V \pm 10\%$
Power Supply			
117 VAC	$117V \pm 10\%$	Commercial power source	—
+24 VDC	$+24V \pm 5\%$	DC output terminals with access cover removed.	If 24V is below 22V or above 29V, check AC power for $117V \pm 10\%$ No adjustments.

800.20 OPERATIONAL SYSTEM TEST

OPERATIONAL TEST	RESULT	PROCEDURE
1. Connect the modular cord of a key telephone to a "HOT" jack.	1. A short tone is heard from the speaker of the instrument.	1. Normal
	2. No tone: No reaction	2.1 Check the cabling connection of the instrument especially the polarity of the wires. 2.2 Check the connections of modular cord into the instrument. 2.3 Consult Trouble Shooting Guide (Section 800).
2. Depress the ON/OFF button on the instrument.	1. ON/OFF button lights	1. Normal
	2. Intercom dial tone is heard.	2. Normal
	3. No reaction.	3.1 Change the instrument.

800.20 OPERATIONAL SYSTEM TEST (Cont.)

OPERATIONAL TEST	RESULT	PROCEDURE
<p>3. Depress the ON/OFF button on the instrument again.</p>	<p>1. ON/OFF button extinguishes. 2. Intercom dial tone removed. 3. No reaction.</p>	<p>3.2 Consult Trouble Shooting Guide (Section 900). 1. Normal 2. Normal 3.1 Change the instrument. 3.2 Consult Trouble Shooting Guide (Section 900).</p>
<p>4. With the instrument in an idle state, depress the MUSIC button.</p>	<p>1. Background music is heard (Channel 1). 2. No reaction</p>	<p>1. Normal 2.1 Check that the instrument is in on-hook state. 2.2 increase volume on instrument with voice volume knob. 2.3 Check the music source (Channel 1) connection at KSJ. 2.4 increase volume of music source. 2.5 Consult Trouble Shooting Guide (Section 900).</p>
<p>5. Adjust the voice volume knob (closest to the user) on the instrument</p>	<p>1. Volume of music is increased or decreased, as desired. 2. No reaction</p>	<p>1. Normal 2. Consult Trouble Shooting Guide (Section 900).</p>
<p>6. Depress the MUSIC button a second time.</p>	<p>1. Background music is heard (Channel 2). 2. No reaction</p>	<p>1. Normal 2.1 Check the music source (Channel 2) connection at the KSJ. 2.2 increase volume on instrument with voice volume knob.</p>

800.20 OPERATIONAL SYSTEM TEST (Cont.)

OPERATIONAL TEST	RESULT	PROCEDURE
7. Depress the MUSIC button for the third time.	1. Music is turned off. 2. No reaction.	2.3 Increase volume of music source. 2.4 Consult Trouble Shooting Guide (Section 900). 1. Normal 2.1 Change instrument. 2.2 Consult Trouble Shooting Guide (Section 900).
8. Depress the DND button (DND is a programmable feature):	1. DND button is lit. 2. No reaction.	1. Normal 2.1 Check DND programming status. 2.2 Consult Trouble Shooting Guide (Section 900).
9. Depress the DND button a second time.	1. DND button is extinguished. 2. No reaction.	1. Normal 2. Consult Trouble Shooting Guide (Section 900).
10. Place test instrument in tone signaling mode (SLIDE SWITCH). From another instrument place an intercom call to the test instrument.	1. Tone ringing is heard. 2. Tone ringing is not heard.	1. Normal 2. Consult Trouble Shooting (Section 900) Guide
11. Adjust the tone volume knob (rear knob).	1. Tone ringing volume is increased or decreased as desired. 2. No reaction.	1. Normal 2. Change instrument.
12. Depress the ON/OFF button.	1. The tone ringing stops and ON/OFF button lights. 2. No reaction	1. Normal 2. Consult Trouble Shooting Guide (Section 900)

600.20 OPERATIONAL SYSTEM TEST (Cont.)

OPERATIONAL TEST	RESULT	PROCEDURE
13. Test station is in speaker-phone mode.	1. Volume is received through the built in speaker in the instrument. ON/OFF button is lit. 1.2 Speech is transmitted through microphone of the instrument. 2.1 Voice not received. 2.2 Speech not transmitted.	1.1 Normal 1.2 Normal 2.1 Change instrument. 2.2 Ensure the handset is in on-hook mode. 2.3 Consult Trouble Shooting Guide (Section 900).

900.30 INTERCOM FUNCTIONS TEST

OPERATIONAL TEST	RESULT	PROCEDURE
<p>1.1 Lift the handset or depress the ON/OFF button, and dial another instrument that is in the TONE signalling mode.</p> <p>NOTE: Perform the test with handset lifted; when test complete, perform test again using ON/OFF button.</p>	<p>1. ON/OFF button lights (when using ON/OFF button).</p> <p>2. Intercom lamp (HOLD button) of called key station flashes at 30 ipm.</p> <p>3. Intercom ring back tone heard (TONE mode).</p> <p>4. Intercom busy tone heard.</p> <p>5. DND intercept tone heard.</p> <p>6. Error tone is heard.</p>	<p>1. Normal</p> <p>2. Normal</p> <p>3. Normal</p> <p>4. Check called instrument for off hook condition.</p> <p>5. Check called instrument for DND mode.</p> <p>6.1 Check connection of called instrument.</p> <p>6.2 Check the Trouble Shooting Guide (Section 900).</p>
<p>1.2 Called station answers by lifting the handset.</p>	<p>1. The flashing HOLD button at the called station stops and light extinguishes.</p> <p>2. Ring back tone is stopped.</p> <p>3. Conversation established.</p>	<p>1. Normal</p> <p>2. Normal</p> <p>3. Normal</p>
<p>1.3 Hang up the receiver or depress ON/OFF button.</p>	<p>1. Connection disconnected.</p>	<p>1. Normal</p>
<p>1.4 Place the called instrument in the handsfree talk back (voice) mode. Make another intercom call.</p>	<p>1. Triple beep tone is heard.</p> <p>2. Handsfree communication available at called instrument.</p> <p>3. HOLD button flashes (30 ipm) at called instrument.</p> <p>4. Intercom call is not connected.</p>	<p>1. Normal</p> <p>2. Normal</p> <p>4. Consult Trouble Shooting Guide (Section 900).</p>

800.30 INTERCOM FUNCTIONS TEST (Cont.)

OPERATIONAL TEST	RESULT	PROCEDURE
<p>2.1 Lift handset or depress ON/OFF button and dial another instrument. From a third instrument (in the same internal page zone), lift handset or depress the ON/OFF button and depress the PICK-UP button</p>	<p>1. Ringing at called station is stopped.</p> <p>2. The PICK-UP instrument is connected to the instrument that placed the call.</p> <p>3. No connection Note: ICM calls to key stations in handsfree mode cannot be picked up</p>	<p>1. Normal</p> <p>2. Normal</p> <p>3.1 Ensure the PICK-UP instrument is in the same internal page zone as the instrument that is ringing (programming).</p> <p>3.2 Consult Trouble Shooting Guide (Section 900).</p>
<p>2.2 Hang up the receiver or depress ON/OFF button.</p>	<p>1. Connection discontinued.</p>	<p>1. Normal</p>
<p>3.1 Lift handset or depress the ON/OFF button and dial another instrument.</p>	<p>1. Dialed instrument rings according to the slide switch setting. HOLD key flashes.</p>	<p>1. Normal</p>
<p>3.2 Depress MESSAGE WAIT button. Hang up receiver or depress ON/OFF button</p>	<p>1. Ringing stops at called instrument and MESSAGE WAIT button flashes at 15 ipm.</p> <p>2. Ringing does not stop or M/W button does not flash.</p>	<p>1. Normal</p> <p>2. Consult Trouble Shooting Guide (Section 900).</p>
<p>3.3 At the instrument with the 15 ipm flash on M/W button, lift handset or depress the MESSAGE WAIT button.</p>	<p>1. The instrument that sets the M/W rings in tone ringing mode regardless of the slide switch setting.</p>	<p>1. Normal</p>
<p>3.4 The ringing instrument lifts handset or depresses ON/OFF button.</p>	<p>1. Connection made, ringing stops.</p> <p>2. MESSAGE WAIT button extinguishes.</p> <p>3. MESSAGE WAIT button stays flashing.</p>	<p>1. Normal</p> <p>3.1 Repeat test 3.3 as up to 5 messages can be left.</p> <p>3.2 Consult Trouble Shooting Guide (Section 900).</p>

800.30 INTERCOM FUNCTIONS TEST (Cont.)

OPERATIONAL TEST	RESULT	PROCEDURE
3.5 Hang up receiver or depress ON/OFF button.	1. Instrument idle	1. Normal
4.1 Lift the handset or depress ON/OFF button and dial a busy or DND instrument with EXEC/SECY programmed.	1. The ringing is automatically forwarded to the SECY instrument.	1. Normal
	2. Ringing is not forwarded.	2.1 Confirm the programming of the EXEC/SECY assignment. 2.2 Consult Trouble Shooting Guide (Section 900).
4.2 Hang up receiver or depress ON/OFF button.	1. Instrument idle	1. Normal
5.1 Lift the handset or depress the ON/OFF button, and dial a busy instrument (not programmed EXEC/SECY)	1. Busy tone heard by calling instrument.	1. Normal
5.2 Depress CAMP-ON button.	1. Muted CO ringing tone is heard at called instrument.	1. Normal
	2. CAMP-ON button flashes at 30 IPM.	2. Normal
	3. Ring back tone heard at calling instrument.	3. Normal
	4. Any of the above fail to react.	4. Consult Trouble Shooting Guide (Section 900).
5.3 From the busy instrument with the flashing CAMP-ON button and muted ringing:		
A. Place existing call on hold, or	1. Muted ringing continues.	1. Normal
B. Hang up receiver or depress ON/OFF button, then	1. Muted ringing changes to normal tone ringing	1. Normal
C. Depress the flashing Camp-on button.	1. Ringing discontinues.	1. Normal

800.30 INTERCOM FUNCTIONS TEST (Cont.)

OPERATIONAL TEST	RESULT	PROCEDURE
	2. Flashing CAMP-ON button extinguishes.	2. Normal
	3. Existing CO call goes on Ex-Hold	3. Normal
	4. Connection made with camp-on caller	4. Normal
5.4 Hang up receiver or depress ON/OFF button,	1. Instrument idle.	1. Normal
6.1 Lift the handset or depress the ON/OFF button and dial 70.	1. Page warning tone is heard on all instruments.	1. Normal
	2. Voice page is heard.	2. Normal
	3. Page warning tone or voice page is not heard.	3.1 Check programming of instruments. 3.2 Check that key sets are not off-hook or in DND mode. 3.2 Consult Trouble Shooting Guide (Section 900).
	4. Busy tone is heard.	4. One or more int zones are in use.
	5. Page cuts off	5. Check paging length programming
6.2 Replace handset or depress the ON/OFF button.	1. Page stops.	1. Normal
	2. Telephone idle.	2. Normal

S00.40 CO LINE FUNCTIONS TEST

OPERATIONAL TEST	RESULT	PROCEDURE
1.1 Lift the handset or depress the ON/OFF button and depress a CO line button.	1. The CO line button lights steady. 2. CO dial tone is heard. 3. CO line button not lit. 4. CO dial tone is not heard. 5. Error tone is heard and button is dark.	1. Normal 2. Normal 3. Replace instrument. 4.1 Check connections of CO line. 4.2 Consult Trouble Shooting Guide (Section 900). 5. Confirm CO Line/Group access assignments.
1.2 Dial desired CO number.	1. Dial tone removed and call is connected. 2. Dial tone remains and call is not connected.	1. Normal 2. Consult Trouble Shooting Guide (Section 900).
1.3 Replace the handset or depress ON/OFF button.	1. CO line button extinguishes. 2. Instrument idle. 3. CO line button remains lit.	1. Normal 2. Normal 3. Consult Trouble Shooting Guide (Section 900).
2.1 Place a CO line call to the system.	1. CO ringing is heard. 2. CO ringing is not heard. 3. The CO line button of the ringing line flashes at 30 IPM. 4. The CO line button of the ringing line does not flash.	1. Normal 2.1 Confirm the CO ringing assignment, day or nite mode. 2.2 Check the CO line connection. 2.3 Consult Trouble Shooting Guide (Section 900). 3. Normal 4. Consult Trouble Shooting Guide (Section 900).

800.40 CO LINE FUNCTIONS TEST (Cont.)

OPERATIONAL TEST	RESULT	PROCEDURE
<p>2.2 Lift the handset or depress the ON/OFF button and depress the flashing CO line button.</p>	<p>1. CO line button lights steady. 2. CO ring stops. 3. Connection established.</p>	<p>1. Normal 2. Normal 3. Normal</p>
<p>3.1 While still connected to the CO line, depress the transfer button and dial an instrument.</p>	<p>1. The CO line is placed automatically on EXCLUSIVE HOLD: A. CO line flashes 120 IPM on transferring instrument. B. CO line lights steady on all other instruments. 2. MUSIC-ON-HOLD is transmitted to the holding CO line. 3. No MUSIC-ON-HOLD is transmitted to CO line. 4. The dialed instrument is signaled in accordance with the SLIDE SWITCH.</p>	<p>1. Normal 1. Normal 1. Normal 2. Normal 3.1 Check music source. 3.2 Check connectors of music Channel 2. 3.3 Consult Trouble Shooting Guide (Section 900) 4. Normal</p>
<p>3.2 From the calling instrument replace the handset or depress the ON/OFF button.</p>	<p>1. CO line button as follows: A. CO line flashes at 120 IPM at dialed instrument. B. CO line lights steady on all other instruments. 2. Tone ringing is heard at the transferred instrument. 3. CO line not transferred.</p>	<p>1. Normal 1. Normal 2. Normal 3. Consult Trouble Shooting Guide (Section 900).</p>

4.0 CO LINE FUNCTIONS TEST (Cont.)

OPERATIONAL TEST	RESULT	PROCEDURE
3.3 At the ringing instrument, lift the handset or depress the ON/OFF button and depress the 120 IPM flashing CO line button.	<ol style="list-style-type: none"> 1. Tone ringing is stopped. 2. CO line button lights steady. 3. Conversation established. 	<ol style="list-style-type: none"> 1. Normal 2. Normal 3. Normal
4.1 While connected to the CO line, depress CONF BUTTON.	<ol style="list-style-type: none"> 1. CO line button reacts as follows: <ol style="list-style-type: none"> A. CO line appears steady at instrument depressing CONF BUTTON. B. CO line button lights steady at all other instruments. 2. CO line does not go on EXCLUSIVE HOLD. 	<ol style="list-style-type: none"> 1. Normal 1. Normal
4.2 Dial another instrument.	<ol style="list-style-type: none"> 1. Dialed instrument rings according to SLIDE SWITCH position. 2. Dialed instrument does not ring. 	<ol style="list-style-type: none"> 1. Normal 2. Consult Trouble Shooting Guide (Section 900).
4.3 At ringing instrument lift handset.	<ol style="list-style-type: none"> 1. Tone ringing is stopped. 2. intercom connection is made. 	<ol style="list-style-type: none"> 1. Normal 2. Normal
4.4 Conference initiator depress CONF. BUTTON. (upto 9 parties can be set into conference)	<ol style="list-style-type: none"> 1. Called instrument hears MOH. 2. Conference initiator hears intercom dial tone. 3. No MOH or dial tone. 	<ol style="list-style-type: none"> 1. Normal 2. Normal 3. Consult Trouble Shooting Guide (Section 900).

800.40 CO LINE FUNCTIONS TEST (Cont.)

OPERATIONAL TEST	RESULT	PROCEDURE
<p>4.5 Conference initiator depress CONF. BUTTON again.</p>	<p>1. All parties connected to conference.</p> <p>2. Conference not connected.</p>	<p>1. Normal</p> <p>2. Consult Trouble Shooting Guide (Section 900).</p>
<p>4.5 All Instruments in the conference replace their receivers.</p>	<p>1. Any CO line remain busy and initiators CONF button remains lit.</p> <p>2. Conference not dropped.</p>	<p>1. Normal</p> <p>2. Consult Trouble Shooting Guide (Section 900).</p>
<p>4.7 At CONF station while on-hook press CONF button.</p>	<p>3. Any CO lines and the CONF 1 Normal button go dark.</p>	
<p>5.1 Lift handset or depress the ON/OFF button and depress a CO line button.</p>	<p>1. CO dial tone heard.</p>	<p>1. Normal</p>
<p>5.2 Allow CO dial tone to time out.</p>	<p>1. CO busy tone is heard.</p>	<p>1. Normal</p>
<p>5.3 Depress FLASH button</p>	<p>1. New CO dial tone is heard.</p> <p>2. No flash function occurs.</p>	<p>1. Normal</p> <p>2.1 Confirm the FLASH time programming.</p> <p>2.2 Consult Trouble Shooting Guide (Section 900).</p>
<p>6. Repeat test for all CO lines at all instruments.</p>		

900. TROUBLE-SHOOTING**900.10 GENERAL INFORMATION****900.11 INTRODUCTION**

This section provides common maintenance, trouble-shooting, and repair instructions for the NC-1648 Digital Hybrid Key System. It is advisable to use the latest issue manual and supporting documentation whenever possible.

The NC-1648 equipment architecture is modularly designed using "plug-in" replaceable type printed circuit boards (KTU's) and other self-contained integral assemblies (power supply, DSS console, key telephones). The system is completely solid state making extensive use (on the KTU's) of IC's and hybrid circuits. These features enable maintenance personnel to quickly identify and isolate failures through the substitution of known good KTU's and/or assemblies until the fault is corrected, and normal system operation is restored. Trouble localization and isolation to the replaceable assemblies requires no special knowledge of solid-state electronics or microprocessor programming techniques.

The NC-1648 requires no involved or complicated mechanical procedures for installation or removal of peripherals. In trouble-shooting, all cables, plugs, clamps, and attaching hardware should be removed and reinstalled carefully.

900.12 PREVENTIVE MAINTENANCE

A systematic preventive maintenance program is essential to reduce the possibility of system failures. The routines for general-type servicing which include cleaning, inspecting, and lubrication should be performed on a semi-annual and annual schedule. More frequent intervals are required where excessive environmental conditions exist, such as, high temperature, humidity, dust, etc. These routines should include, but are not limited to the following.

- Hardware and cabling. Check for general mechanical integrity, no loose or broken wires, plugs, or connectors. Tighten or repair as necessary.
- KSU cabinet exterior. Clean exterior of cabinet using a soft cloth dampened with soap or mild detergent.
- Air vents. Inspect air vents located on the sides and front of the KSU cabinet for unrestricted air passage.
- MDF/Cabling. Inspect the MDF for loose wires, obstructions, dust and dirt.
- Printers. Lubricate in accordance with manufacturers recommendation.

900.13 TEST EQUIPMENT

The following test equipment and tools are required in performing preventive maintenance, trouble-shooting, and repair on the NC-1648.

- Digital Voltmeter (input impedance 16 Megohm)
- DTMF/Dial-Pulse hand-held test telephone
- Static wrist strap
- Standard telephone repairman's hand tools

900.14 SPARE PARTS

The trouble-shooting and repair instructions are based on the assumption that spare printed circuit boards (KTU's) and other replaceable assemblies are available to the repairman either on-site or at a central warehouse/storeroom location.

Table 9.1 lists the recommended spare parts to support the NC-1648 system. This recommendation can be added to or reduced depending upon the quality of service required. Experience has shown that the required ratio of spares goes down as the number of installed systems goes up. In addition to spare KTU's and instruments, fuses, jacks, wire, and terminal blocks should be kept as spares.

900.15 FIELD SERVICE ENGINEERING

The installation, trouble-shooting, and repair of the NC-1648 are described in detail within this manual. However, many field type questions, i.e. application requirements and trouble-shooting assistance, arise requiring support. Such services are available at NorthCom Field Service.

900.20 DIAGNOSTIC PROGRAMS AND TESTS**900.21 DIAGNOSTIC PROGRAMS**

The NC-1648 has various diagnostic programs that test the system operation. The programs are either continual or daily. The time of the daily diagnostic testing is programmable as part of the system parameters. Daily diagnostics are not assigned to run under default data. The status of the diagnostic tests are displayed on LED's located on the CFB. The diagnostic monitor LED's provide a simple yet effective "confidence" display of the system's health.

The daily diagnostic tests are as follows:

- CPU Test
- EPROM Verification Test
- RAM Memory Test

The active diagnostic tests are as follows:

- Hard System Restart Accumulation Test
- Fuse Test
- Processor Operation Test

The following follows a hard restart or system initialization:

- CODEC and filter test
- Watchdog timer enable

Table 9-3 (CPB) lists the LED conditions for the above tests.

900.22 POWER SUPPLY

The power supply is equipped with test points for manual testing of voltage output with a digital meter. The AC input is protected by a fuse and the DC output is protected by a fuse.

900.23 FUSES

Table 9.2 lists the fuses within the NC-1648. The list contains fuse ratings and areas fused. When testing for a blown or defective fuse be sure to use a meter, as fuses that are defective may visually appear to be good.

900.24 INITIALIZATION TEST

When performing the initial power-up sequence or RESET operation, the monitor LED's should light in a specific pattern. There are eight (8) monitor LED's on the CPB that indicate results of initialization tests and are used to display problems associated with the system central processor or peripheral circuits.

- Operation 1 - LED 1 will light when the CPU test is executed and no fault is detected.
- Operation 2 - LED 2 will light steady upon successful completion of the EPROM verification test.
- Operation 3 - LED 3 and LED 4 light simultaneously if a successful RAM memory test is executed. LED 3 will be extinguished if four (4) hard system resets (cold starts) are detected within any sixty (60) minute period.
- Operation 4 - LED 5 will light if a successful FUSE test is executed. All PCB's with fuses are tested. Cards having Normal/Service switches must be placed in the normal mode for the test to be executed on the cards.

Operation 5 - LED 6 will light steady if a successful CODEC and filter test is executed. Cards placed in the service mode will not be subjected to the test.

Operation 6 - LED 7 should start flashing at a rate of two (2) seconds ON and two (2) seconds OFF. This operation indicates a NORMAL condition as continual processing operations are occurring.

Operation 7 - LED 8 should light steady at the completion of the start up initialization sequence to indicate that the system watchdog timer is enabled. If the system stops executing instructions, this LED will be extinguished.

900.25 KEY TELEPHONE TEST

Each NC-1648 Key Telephone can be tested manually. This test is a data transmission test and communication test. Since the commands come to the key telephone via data transmission, intermittent problems can be the result of communication errors between the key telephone and KSU. This test will monitor communication errors in a cumulative manner.

The test is local to the telephone and will not affect data transmission to the KSU. The display is over the CO line and function buttons. When the display is activated, the station operation is not altered, but the LED's on the buttons follow the test. Upon clearing the test all LED's will return to normal.

To activate the test, press CO line buttons 1 and 3 simultaneously. The ON/OFF, Message Waiting, DND and Camp-On function button LED's light steady. This indicates you are in the test mode.

The KSU-to-key telephone transmission error table is displayed on CO line buttons 1 through 8. The values are as follows:

<u>CO LINE BUTTON</u>	<u>ERROR COUNT</u>
1	128 errors
2	64 errors
3	32 errors
4	16 errors
5	8 errors
6	4 errors
7	2 errors
8	1 error

The error values are cumulative. For example, if the LED's of CO line keys 4, 6 and 8 are on 21 errors have been detected. The error count will continue to be updated while in the test mode.

With this system limited transmission errors are normal, therefore, some errors will be displayed. Data transmission problems are occurring when error rates tend to be more frequent. If you are in the test mode and errors accumulate, there is a reason to suspect problems. A station located at or beyond the maximum distance from the KSU will experience excessive data transmission errors.

Other CO line and function button LED's signal key telephone function activities. They are as follows:

- CO Line Button 9 = always extinguished
- CO Line Button 10 = LED is on if the key telephone microphone is not activated
- CO Line Button 11 = LED is on if the key telephone speakerphone is activated
- CO Line Button 13 = LED is always on
- CO Line Button 14 = LED is on if the handset is off-hook.

To clear the error display (CO Line Keys 1 through 8) press CO Line Button 1 and dial pad key 7 simultaneously. To exit the test, press any button.

900.30 TROUBLE-SHOOTING PROCEDURES

900.31 FAULT CLASSIFICATION

Reported problems come from a variety of people under differing conditions, therefore all trouble reports should be thoroughly examined so that the exact problem is understood. Do not always suspect the NC-1648 equipment. Check external interface equipment, such as the MDF, interconnection points, cabling, or central office. Once the operational description of the fault has been determined and if the trouble has been isolated to the NC-1648, the following type of information should be investigated to help define the source of the problem.

- A) Were any changes made recently to the customer data base assignments that could cause the problem?
- B) Is the trouble condition associated with one circuit, a particular section or sections of circuits, or common to all circuits?
- C) Is the trouble intermittent or continuous?
- D) Were any changes made recently to cabling that would cause the problem?

- E) Could the trouble be caused by "cross symptoms", i.e. two failures which together mask the expected symptom associated with a particular fault?

900.32 SYSTEM FAILURES

Various problems affect the whole system. These are normally related to power failures, central processor failures, or memory failures.

900.321 POWER FAILURES

The loss of commercial power will shut down the system, unless battery back-up is provided. Other power failures occur when AC cords are removed from outlets, circuit breakers are tripped, or fuses blown. Test voltages with voltage meter to determine the source of the power problem. Start at the power supply and work toward the source of the fault.

900.322 FAILURE INDICATORS

There are LED's located on the CPB card that can be used in trouble-shooting system faults due to general processor failures.

- A) LED 1 will extinguish if the system fails the daily CPU test.
- B) LED 2 will extinguish if the SCB communication test fails or the daily EPROM verification test fails.
- C) LED 3 will extinguish if four (4) hard system resets (cold starts) are detected within any sixty-minute (60) period.
- D) LED 4 will extinguish if the daily FAM test fails.
- E) LED 5 will extinguish if a fuse fails the continuity test.
- F) LED 6 will extinguish if at the time of a cold start the CODEC and filter test fails.
- G) LED 7 will extinguish if the processor operation fails.
- H) LED 8 will extinguish if the system stops executing instructions. If daily diagnostics have not been run, reset the system (when idle) and observe the above LED's for a normal (all LED's ON or flashing) display.

900.33 STATION/CO LINE FAILURES

Station and CO line card failures are naturally assumed to be the most prevalent, since there are usually more KTU's and peripheral hardware. The following statements should help in isolating and categorizing these failures:

A) Station Failures:

- All stations failing — common equipment problem.
- The failing stations are located on the same surface KTU-KTU problem.
- Different problem happening at various stations — check for multiple problems; check station instrument.
- The fault is intermittent — test for condition that creates the problem.
- Single Line Telephone (SLT) problems — SIB or SOB problem.

B) CO Line Failures:

- All CO lines failing — check CO lines; common equipment.
- The failing CO lines are on the same interface PCB-PCB problem.
- Can't dial out on CO lines — check for missing CNB.
- Different problems happening on various CO lines — check for multiple problems.
- The fault is intermittent — test for condition that creates the problem.

900.34 UNRELATED MULTIPLE FAILURES

Trouble reports will at times contain multiple faults that are unrelated to each other, i.e. problems with two stations supported by different interface KTU's. These can be individual faults; requiring individual troubleshooting on each fault; or could be common equipment faults.

900.35 DSS FAILURES

The DSS is supplied its data and power from the Tone Board (TNB). Each DSS is protected by a fuse located on the TNB. The power and data to the DSS is fused. DSS faults will be in the DSS unit, wiring, or TNB. SLF failures are associated with the same interface circuits.

900.36 FEATURE OPERATION FAILURES

All operational features are controlled by the software routines and specific data base assignments. Most features are provided exclusively by the software; however, others require hardware or supporting equipment. For this reason, data base assignments should be checked before corrective maintenance is performed. Also check for proper usage by the customer. Feature failures are sometimes the fault of the user. Features that utilize hardware or supporting equipment

could have faulty equipment. This equipment should be checked. The following is the list of features that use additional hardware or supporting equipment:

<u>FEATURE</u>	<u>HARDWARE/SUPPORTIVE EQUIPMENT</u>
Background Music	— Music source w/MDF connections; Tone Board (TNB)
Memory Battery Back-Up	— Lithium battery on CPB
System Battery Back-Up	— 24 VDC battery package, Battery Charging Board (BOB)
Conference	— Conference Board (CNB)
Emergency/Power Transfer	— CO Transfer Board (CTB)
External Zones Page	— Output relays on Tone Board (TNB)
Music-On-Hold	— Music source w/MDF connections; Tone Board (TNB)
SMDR	— Switch on CPB; printer
Time of Day	— 24 VDC battery package
Mini-Printer	— Wired connections, Tone Board (TNB), Central Processing Board (CPB)
Loud Bell Control	— Wired connections, Tone Board (TNB)

The remaining features are totally software; therefore, the loss of commands from the CPU and requests from telephones, or memory failures will result in feature failures. Check the CPB, HIS, Peripheral Boards, and instruments.

900.40 HARDWARE/PCB INFORMATION**900.41 GENERAL**

The following information on printed-circuit boards provides certain tabular color locations and procedural directions for removal and replacement. Also, a table of card functions, controls, options, and fault conditions is presented in this section.

900.42 COLOR CODING AND LOCATIONS

The printed circuit boards (KTU's) which contain the common control, switching, and peripheral circuits are housed in the KSU. Two color coded ejector tabs are provided on the outer-edge of each board for inserting the board into a shelf connector. The section of a shelf

TABLE 9.1
NC-1648 SPARE PARTS
No. of Systems Installed

DESCRIPTION	1-5	6-10	11+
CPB	1	1	2 + 1 per additional 10
HIB	1	1	2 + 1 per additional 10
TNB	1	1	2 + 1 per additional 10
KIB	1	2	Note 1
COB-T (If equipped)	1	2	Note 1
SCB (If equipped)	1	2	2
SIB (If equipped)	1	1	Note 1
Key Telephone	4	6	8
Power Supply	1	1	1
DC/DC Converter	1	1	1
CNB	1	1	2 + 1 per additional 10
DSS	1	1	1
COB-P (If equipped)	1	2	Note 1
KTB (If equipped)	1	1	1
KSU	1	1	1

Note 1: 10% of the Premier 1648 installed base of station and line cards.

TABLE 9.2

Location	Designator	Rating	Equipment Affected
DC/DC Converter	F1	8A/250V	System
	F2	5A/250V	System
TNB (Note 1)	F1	1.25A/250V	Data/Power — DSS 1, BLF 1-3
	F2	1.25A/250V	Data/Power — DSS 2, BLF 4-6
	F3	0.5A/250V	Power — Mini-Printer
KIB (Note 1)	F1	0.5A/250V	Data/Power — Stations 1/2
	F2	0.5A/250V	Data/Power — Stations 3/4
	F3	0.5A/250V	Data/Power — Stations 5/6
	F4	0.5A/250V	Data/Power — Stations 7/8
External Power Supply	F1	5A/250V	AC Input
	F2	12A/250V	DC Output
BCB	F3	12A/250V	Battery Charging

Note 1: The only way to verify the condition of the slow-blow type station fuses are to test them with a volt-ohm meter or by substitution with a known good fuse. (A blown station fuse is normally due to improper or shorted station wiring.)

SUMMARY OF PCB FUNCTIONS, CONTROLS, OPTIONS, AND FAULT CONDI

KTU BOARD	FUNCTION	CONTROL	OPTIONS
<p>Central Processing Board (CPB)</p> <p>Color-coded-yellow</p>	<ol style="list-style-type: none"> 1. Central Processing Unit (CPU) to control system operation. 2. Real Only Memory (ROM) with factory-set operating instructions. 3. Random Access Memory (RAM) protected by a lithium battery on PCB. 4. "Scratch Pad" RAM working area for dynamic data. 5. Hard restart switch for manual system restart. 6. Provides output to RS-232 port for SMDR. 	<ol style="list-style-type: none"> 1. Keeps LED 1 illuminated when CPU daily test is executed and no fault is detected. 2. Keeps LED 2 illuminated upon completion of daily EPROM verification test with no fault detected. 3. Keeps LED 2 illuminated while communication with SCB is functioning properly. 4. Keeps LED 3 & 4 illuminated upon completion of daily RAM test with no fault detected. 5. Tests for 4 hard system resets within any 60 min. period, LED 3 extinguished if resets occur. 6. Test fuses on all PCB's. LED 5 is illuminated when all active fuses pass test. 7. Test CODEC and filter on all active cards, LED 6 illuminated upon successful completion of test. 	<ol style="list-style-type: none"> 1. Switch 1-Write Memory <ul style="list-style-type: none"> * <u>Off</u>-protects from forced loading of default data base <u>On</u>-allows update of customer data base. 2. Switch 2-Clear to Send Disable <ul style="list-style-type: none"> <u>Off</u>-for terminal equipped to send CTS signal (mini-p <u>On</u>-Normal termin operation. 3. Switch 3-Soft Restart Monitor <ul style="list-style-type: none"> <u>Off</u>-enables soft restarts to be printed with SMDR * <u>On</u>-Normal SMDR printing 4. Switch 4-Soft/ Hard Restart Switc <ul style="list-style-type: none"> <u>Off</u>-will hard restart upon detection of bit error * <u>On</u>-will soft restart upon detection of bit error 5. Switch 5-SMDR <ul style="list-style-type: none"> <u>Off</u>-SMDR not use <u>On</u>-Enables SMD tracking of system generated calls. <p>* Normal Position</p>

TABLE 9.3 (Cont.)
SUMMARY OF PCB FUNCTIONS, CONTROLS, OPTIONS, AND FAULT CONDITIONS

KTU BOARD	FUNCTION	CONTROL	OPTIONS	FAULT CONDITIONS
CPB (Cont.)		<ol style="list-style-type: none"> 8. Test operation of CPU, LED 7 flashes at 2 sec. on/2 sec. off under normal conditions. 9. Enables watch dog timer upon completion of initialization sequence LED 8 illuminated. 10. Works with HIB, TNB & CNB to make system operational. 	<ol style="list-style-type: none"> 6. Switch 6-Printer output format Off-29 character printer (mini-printer) On-80 character printer. 7. Switch 7 Unused. 8. Switch 8 Unused. 	
Highway-Interchange Board (HIB) Color Coded-Orange	<ol style="list-style-type: none"> 1. Provides the PCM system clock. 2. Synchronizes the CPB with the back-plane voice and memory addresses. 3. Multiplex the PCM voice highways. 	<ol style="list-style-type: none"> 1. Works with CPB, TNB & CNB to make the system operational. 	<ol style="list-style-type: none"> 1. None. 	<ol style="list-style-type: none"> 1. System fails to operate when power is available. 2. Cannot receive dial tone. 3. Failure to connect to dialed party. 4. Inoperative features. 5. Partial failures in system voice.
Tone Board (TNB) Color Coded-Brown	<ol style="list-style-type: none"> 1. Generates supervisory tones & allocates these tones to peripheral circuits. 2. Interfaces Music-On-Hold/Background Music. 3. Interfaces external paging ports. 	<p>Fuse 1: data/power DSS 1</p> <p>Fuse 2: data/power DSS.2</p> <p>Fuse 3: Power for Mini-printer</p>	<ol style="list-style-type: none"> 1. None. 	<ol style="list-style-type: none"> 1. Failure of one or more system supervisory tones or improper tones. 2. Failure to hear Background Music or Music-On-Hold. 3. Failure of external paging.

TABLE 9.3 (Cont.)
SUMMARY OF PCB FUNCTIONS, CONTROLS, OPTIONS, AND FAULT CONDITIONS

KTU BOARD	FUNCTION	CONTROL	OPTIONS	FAULT CONDITIONS
CPB (Cont.)		<ol style="list-style-type: none"> 8. Test operation of CPU. LED 7 flashes at 2 sec. on/2 sec. off under normal conditions. 9. Enables watch dog timer upon completion of initialization sequence LED 8 illuminated. 10. Works with HIB, TNB & CNB to make system operational. 	<ol style="list-style-type: none"> 6. Switch 6-Printer output format Off-29 character printer (mini-printer) On-80 character printer. 7. Switch 7 Unused. 8. Switch 8 Unused. 	
Highway Interchange Board (HIB) Color Coded-Orange	<ol style="list-style-type: none"> 1. Provides the PCM system clock. 2. Synchronizes the CPB with the background voice and memory addresses. 3. Multiplex the PCM voice highways. 	<ol style="list-style-type: none"> 1. Works with CPB, TNB & CNB to make the system operational. 	<ol style="list-style-type: none"> 1. None. 	<ol style="list-style-type: none"> 1. System fails to operate when power is available. 2. Cannot receive dial tone. 3. Failure to connect to dialed party. 4. Inoperative features. 5. Partial failures in system voice.
Tone Board (TNB) Color Coded-Brown	<ol style="list-style-type: none"> 1. Generates supervisory tones & allocates these tones to peripheral circuits. 2. Interfaces Music-On-Hold/Background Music. 3. Interfaces external paging ports. 	<p>Fuse 1: data/power DSS 1</p> <p>Fuse 2: data/power DSS 2</p> <p>Fuse 3: Power for Mini-printer</p>	<ol style="list-style-type: none"> 1. None. 	<ol style="list-style-type: none"> 1. Failure of one or more system supervisory tones or improper tones. 2. Failure to hear Background Music or Music-On-Hold. 3. Failure of external paging.

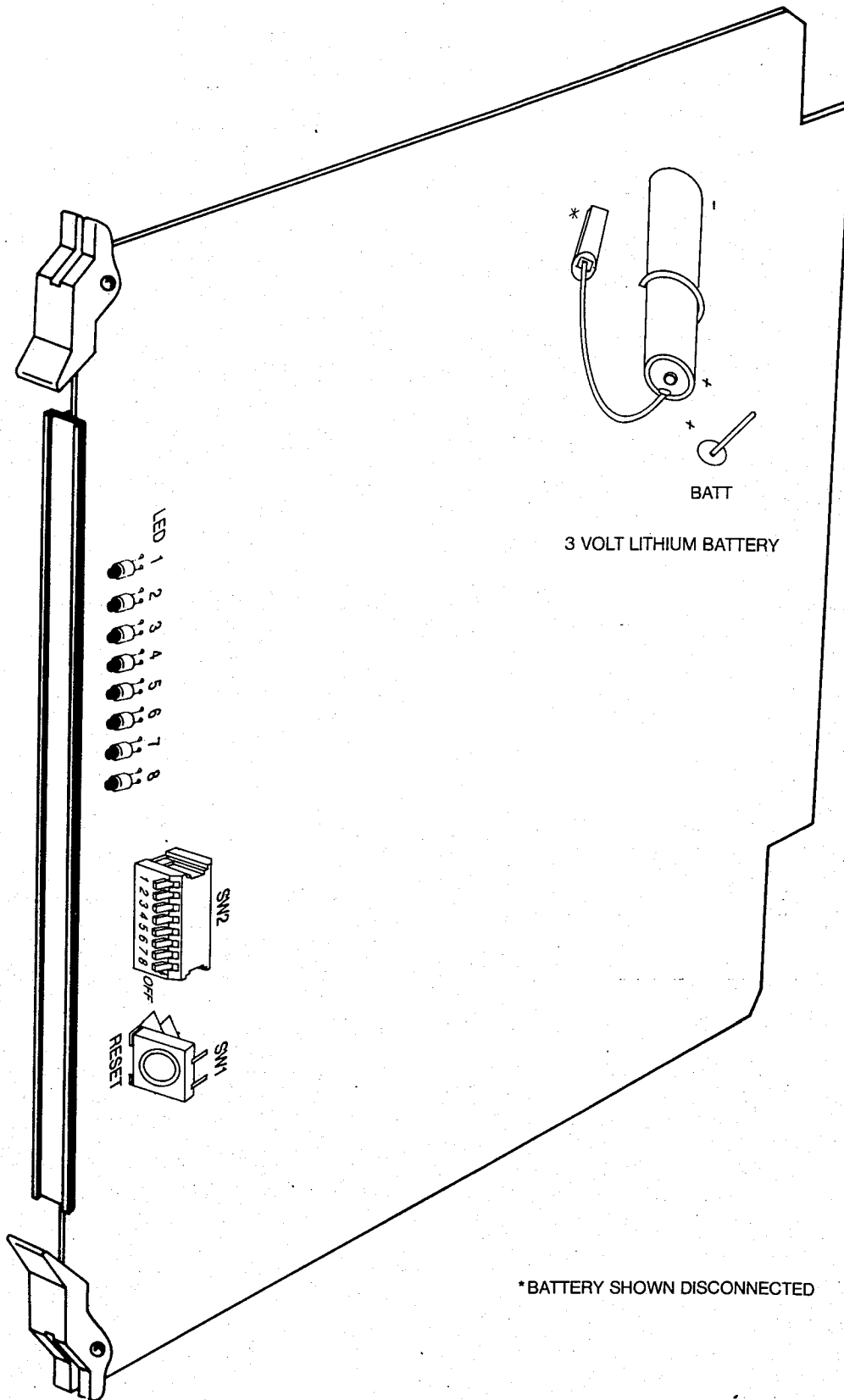

CENTRAL PROCESSING BOARD II

700 FEATURE PACKAGE II DATA BASE PROGRAMMING

700.01 GENERAL DESCRIPTION

The PREMIER NC-1648 Key Telephone System uses Time Division Multiplexing to perform call switching under control of a microprocessor located on the Central Processing Board (CPB). The CPB II has a 80188 microprocessor. This microprocessor directs switching activity and transmits updated status information to each electronic terminal interfaced with the system. These terminals comprise the Key Telephone Sets (KTS), Direct Station Selectors (DSS) and Busy Lamp Fields (BLF). Refer to Figure 2.1.

CENTRAL PROCESSING BOARD (CPB) II located in card position 3, provides the system's 16-bit processor (80188) and memory and controls switching activity. Provides features of "NC-1648 Feature Package II". CPB II contains the same eight (8) LED's used as diagnostic aids. Also the DIP switch assembly provided for setting various system parameters. (Refer to Section 400.21)

700.02 CPB II FEATURES

In addition to the features mentioned in the NC-1648 Installation Manual, the CPB Feature Package II provides the following features:

SMDR ENHANCEMENT

Station Message Detail Recording (SMDR) will provide details on both incoming and outgoing calls. Locally dialed numbers can be excluded from reporting as a data base option.

CALL FORWARD - PRESET

The system data base may be configured so that incoming CO lines, which are programmed to ring a particular station, can after a programmed period of time, be forwarded to another station predetermined in programming. This feature is active if the station normally receiving the CO ring is busy or does not answer the call.

HUNT GROUPS

When an intercom or transferred CO line to a station in a defined hunt group receives a busy, the system will search sequentially for an idle station. Upon finding an idle station within a group, it will ring at that station.

With this feature, the Executive/Secretary feature in CPB I is eliminated.

SYSTEM SPEED DIALING

Up to seventy-six (76) numbers can be stored for use in automatic dialing by stations allowed access to system speed dial. Numbers are stored in two (2) lists: list 1 is numbered 10-45 and list 2 is numbered 50-89. The numbers in list 2 are subject to class of service assignments of stations originating the speed numbers.

Speed bins 46-49 are reserved for special codes. Bin 46 is for setting system time and date.

CO LINE QUEUING

When CO lines are busy, stations can be placed in queue awaiting that CO line or a CO line in the same line group to become available. When a CO line becomes available, the system signals the waiting station. If the waiting station is busy when the queued CO line becomes available, the station is placed at the bottom of the queue list. If a station doesn't answer the queue signal after 20 seconds, that station will be dropped from the queue list.

REAL TIME

The system clock recording time and date is protected from commercial power failure to the system and continues to function.

CONFERENCE

With CPB II the conference controller can place CO lines on hold, remove selected lines from conference and re-enter the holding lines into the conference.

RS232C I/O (FUTURE)

The system can be accessed via an I/O device connected to the system RS232C port. With this, the system data base can be updated and a hard copy printout of the data base can be obtained. Both input and output can occur to the system data base.

CO LINE ACCESS

With CPB II key telephones not allowed access to CO lines will not receive an LED indication of the line's status.

CLASS OF SERVICE

In addition to the 6 class of service assignments available for assignment to stations, there are 5 class of service assignments available for assignment to CO lines.

PBX DIALING CODES

The system will allow five (5) one and two digit PBX access codes to be entered into memory. When one of these codes is dialed, this signals the KSU that toll restriction is to be applied after the next dialed digit after the code. If one of the codes is not dialed, toll restriction does not apply. This allows dialing of PBX extensions 100, 110, 111, etc.

FLASH WITH SPEED DIAL

During the dialing of a station or a system speed number, a flash will occur on a CO line when commanded. A pause will automatically be inserted before the remaining speed dial digits are dialed. When programming a speed number, pressing the flash button enters a flash command. This is counted as a digit. The flash length is determined by system parameters programming.

AUTOMATIC PAUSE INSERTION

A pause will be automatically inserted into station and system speed dial numbers and save redial numbers after a programmed flash in speed dial numbers or after recognizing and dialing a programmed PBX dialing code assigned in the customer data base.

CO LINE RINGING

Any number of stations up to 48 can be assigned to ring on an incoming call. Day and Night Ringing are separate and different stations can ring at night from those that ring during the day.

CALL FORWARD - STATION

Each Key Telephone user may direct intercom calls and transferred CO lines to be forwarded to another station in the system. A forwarded call will signal the receiving station in the TONE mode regardless of the intercom signaling switch mode selection.

DIRECTED CALL PICKUP

In addition to regular call pick up, a station can pick up an intercom call or transferred CO lines of a specific unattended station.

STATION SPEED DIALING

Each station, including single lines, can store 20 speed dial numbers of up to 24 digits each. These numbers are located in bins 00-09 and 90-99.

SAVE NUMBER REDIAL

A number dialed by a station on a CO line can be saved permanently to be used at any time.

LAST NUMBER REDIAL - SINGLE LINES

Single line telephones have the ability to automatically redial the last number dialed.

ATTENDANT PROGRAMMING

Setting system time and date and programming speed dial numbers are done at the attendant's key telephone.

TOLL RESTRICTION

The allow tables have been expanded to contain up to 20 eight digit entries and the deny tables have been expanded to contain up to 10 eight digit entries.

TABLE OF CONTENTS—Cont'd

500.50	BATTERY BACKUP INSTALLATION	5-3
500.51	BATTERY CHARGING BOARD INSTALLATION	5-3
500.52	BATTERY INSTALLATION AND CONNECTIONS	5-3
500.60	KTU INSTALLATION	5-5
500.61	KTU HANDLING	5-5
500.62	KTU INSERTION	5-5
500.63	KTU PROGRAMMING	5-5
500.64	DC/DC CONVERTER	5-5
500.70	CO/PBX LINE CONNECTIONS	5-5
500.71	MDF CONNECTIONS	5-5
500.72	EMERGENCY TRANSFER	5-5
500.80	STATION EQUIPMENT INSTALLATION	5-5
500.81	KEY TELEPHONE INSTALLATION	5-5
500.82	DSS INSTALLATION	5-6
500.83	BLF INSTALLATION	5-6
500.84	SINGLE-LINE TELEPHONE INSTALLATION	5-6
500.85	MINI-PRINTER INSTALLATION	5-7
500.86	WALL MOUNT KIT INSTALLATION	5-7
500.87	HEADSET INSTALLATION	5-7
500.90	EXTERNAL APPARATUS CONNECTIONS	5-8
500.91	CONNECTION OF LOUD BELL CONTROL	5-8
500.92	BACKGROUND MUSIC CONNECTIONS	5-8
500.93	MUSIC-ON-HOLD CONNECTIONS	5-8
500.94	EXTERNAL PAGING CONNECTIONS	5-8
500.95	RS-232C TERMINAL CONNECTIONS	5-8
500.96	STATION MESSAGE DETAIL RECORDING	5-9
500.97	INSTALLATION OF LCD SOFTWARE	5-10
SECTION 600	INITIALIZATION	
600.10	INSTALLATION CHECK LIST	6-1
600.20	POWER UP SEQUENCE	6-1
SECTION 700	CUSTOMER DATA BASE PROGRAMMING	
700.10	INTRODUCTION	7-1
700.20	MEMORY BATTERY BACKUP	7-1
700.30	DSS BUTTON REDEFINITION	7-1
700.40	IMPLEMENTATION	7-4
700.41	PROGRAM MODE ENTRY	7-4
700.42	OVERLAY PROGRAMMING MODE ENTRY	7-4
700.50	SYSTEM PARAMETERS	7-4
700.51	SELECTION-SYSTEM PARAMETERS	7-5
700.52	SELECTION ENTRY-SYSTEM PARAMETERS	7-7
700.60	CO LINE DATA	7-7
700.61	CO LINE DATA BASE ENTRY	7-9
700.70	STATION DATA	7-10
700.71	STATION DATA BASE ENTRY	7-10
700.80	EXCEPTION TABLE DATA	7-11
700.81	EXCEPTION TABLE DATA BASE ENTRY	7-12
700.90	PERMANENT UPDATE PROCEDURES	7-12

TABLE OF CONTENTS—Cont'd

700.100	DISPLAY PROCEDURES.....	7-12
700.101	HARDCOPY PRINTOUT	7-12
700.102	DATA BASE DISPLAY WITHOUT A LISTING DEVICE	7-13
700.103	SYSTEM PARAMETERS DISPLAY.....	7-13
700.104	CO LINE DATA DISPLAY	7-13
700.105	STATION DATA DISPLAY	7-14
700.106	SPEED DIAL DATA DISPLAY	7-14
700.107	EXCEPTION TABLE DATA DISPLAY	7-14
700.110	ATTENDANT SPECIAL PROGRAMMING	7-14
700.111	PROGRAMMING SYSTEM SPEED DIAL NUMBERS.....	7-14
700.112	PROGRAMMING SYSTEM TIME & DATE	7-15
SECTION 800	OPERATIONAL TESTS	
800.10	POWER SUPPLY TESTS	8-1
800.20	OPERATIONAL SYSTEM TEST	8-1
800.30	INTERCOM FUNCTIONS TEST	8-5
800.40	CO LINE FUNCTION TEST.....	8-9
SECTION 900	TROUBLE-SHOOTING	
900.10	GENERAL INFORMATION	9-1
900.11	INTRODUCTION	9-1
900.12	PREVENTIVE MAINTENANCE	9-1
900.13	TEST EQUIPMENT	9-1
900.14	SPARE PARTS.....	9-1
900.15	FIELD SERVICE ENGINEERING	9-1
900.20	DIAGNOSTIC PROGRAMS AND TESTS	9-1
900.21	DIAGNOSTIC PROGRAMS.....	9-1
900.22	POWER SUPPLY	9-2
900.23	FUSES	9-2
900.24	INITIALIZATION TEST	9-2
900.25	KEY TELEPHONE TEST.....	9-2
900.30	TROUBLE-SHOOTING PROCEDURES.....	9-3
900.31	FAULT CLASSIFICATION	9-3
900.32	SYSTEM FAILURES	9-3
900.321	POWER FAILURES	9-3
900.322	FAILURE INDICATORS	9-3
900.33	STATION/CO LINE FAILURES	9-3
900.34	UNRELATED MULTIPLE FAILURES	9-4
900.35	DSS FAILURES	9-4
900.36	FEATURE OPEATION FAILURES	9-4
900.40	HARDWARE/PCB INFORMATION.....	9-4
900.41	GENERAL.....	9-4
900.42	COLOR CODING AND LOCATIONS	9-4
900.43	PCB REMOVAL AND REPLACEMENT GUIDE.....	9-5
900.44	SUMMARY OF KTU FUNCTIONS, CONTROLS, OPTIONS, AND FAULT CONDITIONS.....	9-5

700 FEATURE PACKAGE II DATA BASE PROGRAMMING

700.10 INTRODUCTION

The customer data base consists of the parameters necessary to configure a customer's system for specific applications. All unique customer data base programming is done via the DSS Unit (#1) which is used as a data entry/display device. Normal key system operation is unaffected while updating system memory. Optional printers may also be used to display this information when using the DSS as a programming device.

Upon entering the program mode, the DSS BUTTONS/LED's are redefined by software into 3 different and distinct areas:

1. **Overlay Entry Field** – Used to enter the particular overlay to be programmed (station, exception tables, CO line, system).
2. **Numeric Key Pad** – Used to enter numeric data.
3. **Data Field** – Each overlay contains unique data fields to be programmed.

At the time the system is installed, the system should be initialized to load default data into memory (Switch 8 is turned ON). See Table 7-1 for default values. After initialization, customer data may then be entered to suit a particular customer need.

There are 3 data base areas involved in call processing, customer updating, and hard restart: (Figure 7.11)

1. **Default data base area** – See Table 7-1 for default values. All customer modifications are applied to this data.
2. **Dynamic data base area** – A temporary memory area which administers the customer database update procedures. This area is created by copying the operational memory to a dynamic work space when programming mode is entered.
3. **Operational data base area** – Contains the permanent data base memory. This area is referenced during call processing and is under software and hardware write-protect logic. The contents of the operational data base depends upon the state of the write-protect logic. If enabled (switch 8 is ON), it will contain default data. If disabled (switch 8 is OFF), it will contain previous customer data base values. The result of a hard restart depends on the position of

switch 8. If switch 8 is on, the system will load default data; if it is off, it will load previously entered customer data.

A hard restart occurs when the system is powered up or when the reset button on the CPB is pushed.

*Switch 1 on the CPB is the write-memory switch. This switch should remain ON at all times. Switch 8 should be ON only to load default data. When all eight red LED's on the CPB are lit (refer to Section 6.02 G), switch 8 should be turned OFF to protect the Customer Data Base. Switch 8 should be left off when updating the customer data base. Refer to Figure 4.7 for the location of these switches.

700.20 MEMORY BATTERY BACKUP

The NORTHCOM 1648 utilizes a lithium battery for memory backup in the event of a commercial power failure. The battery has an approximate life of 5 years and is located on the CPB.

Optional system battery backup can also be provided to ensure full system operation during power failure with the addition of a 24 volt battery package. (See Section 400.50 for optional Battery Charging Board)

700.30 DSS BUTTON REDEFINITION

Once entrance to the data base programming mode is accomplished, the bottom two (2) rows of function buttons are redefined.

The upper row of buttons become Overlay Selection Keys (Station CO Line, Exception Tables, System Parameters, and Update Perm). The bottom row of buttons become Function Keys (Enter, Initialize, and Display).

The following is a description of the Function buttons involved. Refer to Figures 7.7 to 7.10 for the location of these buttons.

TABLE 7-1
DEFAULT DATA

FUNCTION	DEFAULT VALUE
Attendant Override	Disabled
Baud Rate Select	Set at 300 baud
Call Forward – Preset	None assigned
Call Forward Timer	Set at 20 seconds
CO Line Class of Service	All lines set at COS 0
CO Line Ringing (Day)	All lines ring at station 10
CO Line Ringing (Night)	All lines ring at station 10
Conference Time Out	Set at 90 minutes
Diagnostic Start Time	Set at 2525 hours
Display	Enabled at all stations
Ex-Hold Recall Timer	Set at 60 seconds
Exception Tables	None assigned
External Night Ring	Disabled
Flash Timer	Set at 2.0 seconds
Hunt Groups	None assigned
Internal Paging/Call Pickup Zones	All stations in zone 1
Internal/External Paging Time Out	Set at 60 seconds
Last Number Redial – SLT's	Enabled
Line Type (CO/PBX)	All lines assigned as CO
Loud Bell Control	Set for night only
Month/Day Setting	Set for month/day format
Outgoing CO line groups (7)	All CO lines in group 1
PBX Dialing Codes	None assigned
Pulse (CO line signalling)	Disabled (all lines set DTMF)
SMDR	All calls recorded
Station Do-Not-Disturb Mode	Enabled for all key stations
Station Class of Service	All stations set for COS 0
Station Call Forward	Enabled for all stations
Station Line Group	All stations in group 1
System Speed Numbers	None assigned
System Hold Recall Timer	Set at 600 seconds
System Speed Access	Enabled for all stations
Time Setting	Set for 12 hour format
Transfer Recall Timer	Set at 60 seconds
Universal Night Answer	Enabled for all CO lines

**TABLE 7-2
NUMBERING PLAN FOR THE NORTHCOM 1648**

DIAL	DESCRIPTION
0	Abbreviated Dialing to Attendant (Station 10)
6	SLT Zone Pickup and Directed Call Pickup (Preceded by Station Number)
9	SLT Line GROUP 1 Access
00-09, 90-99	Station Speed Access Codes – Preceded with SPEED button
10-45, 50-89	System Speed Access Codes – Preceded with SPEED button
11	Secondary DSS position
10-57	Station Directory Numbers
46	Setting Time and Date
70	All Call Page – Internal Zones
71	Internal Page – Zone 1
72	Internal Page – Zone 2
73	Internal Page – Zone 3
74	Internal Page – Zone 4
75	All Call Page – External Zones
76	External Page – Zone 1
77	External Page – Zone 2
78	All Call Page – External and Internal
81	SLT Line Group 2 Access
82	SLT Line Group 3 Access
83	SLT Line Group 4 Access
84	SLT Line Group 5 Access
85	SLT Line Group 6 Access
86	SLT Line Group 7 Access
88	SLT Universal Night Answer Code
* 10- * 45	SLT System Speed Number Selections
#	SLT Ex-Hold Access Code
#	Last Number Redial-Preceded with SPEED button
* #	Single Line Telephone-Last Number Redial

1. **ENTER:** The 'ENTER' button is used at the end of programming the data for each overlay. Valid data will be entered into the dynamic data base. If valid data has been entered, a steady confirmation tone will be heard when this key is depressed. If the data is invalid, an interrupted tone will be heard.

When programming numeric data such as recall timers, conference and paging timers, etc., the ENTER button must be depressed after each numeric entry in order to enter the data.

2. **INIT:** Pressing the 'INIT' button followed by the 'ENTER' button will return that specific data field to default values. Pressing the 'INIT' button and then the 'ENTER' button following any overlay selection key will return that entire overlay to default values.

3. **DISPLAY PERM:** This function will display the contents of the operational memory on the LED display. If a printer is installed, the information will be displayed and printed. This function will print an entry if one has been selected, and print an entire overlay if a specific entry has not been selected. The LED's will not display unless this button is pressed.
4. **DISPLAY TEMP:** To display changes made in temporary memory prior to entering into permanent memory with UPDATE PERM button. Will ensure changes were made correctly.
5. **UPDATE:** The 'UPDATE PERM' key will transfer the dynamic memory to the operational data base when the following conditions have been satisfied:
 - a. The write memory switch (1) was turned on.
 - b. The programming mode was entered.
 - c. Valid data base entered.
 - d. The UPDATE PERM key was the last key pressed before leaving the programming mode.
 - e. The Data Entry button, recessed on the underside of the DSS, is depressed thereby leaving the programming mode.
6. **DISPLAY MODE:** This LED is lit whenever the display mode has been entered. Depressing this button while ON will cancel the display status and return the programmer to status before the display mode was entered.
7. **DUPE:** The 'DUPE' button may be used to duplicate the data from the last entry to the current entry. If no data has been entered, then this function will not be performed. The 'ENTER' or 'NEXT' button must be pressed to store the 'DUPE' (duplicate) information.
8. **NEXT:** Stations or CO lines may be programmed sequentially by using this button (i.e. after programming station 10, depress NEXT and that data will be stored and station 11 automatically ready for programming).

700.40 IMPLEMENTATION

Before attempting any programming, a completed set of customer database sheets should be prepared and available during programming.

700.41 PROGRAM MODE ENTRY

Entering the data base programming mode is achieved by depressing the recessed 'DATA' button on the underside of the primary DSS console. This will cause all of the LED's to illuminate. The 'RELEASE' button should then be pressed five (5) times within ten (10) seconds. This action will extinguish the LED's for approximately five (5) seconds. When the LED's light the second time, overlay selection can begin. If the 'RELEASE' button is not pressed five (5) times within ten (10) seconds, the DSS will automatically return to the idle state. Refer to Figure 7.6.

During the programming mode, the primary DSS will no longer function as an attendant console for processing calls. However, the associated key telephone (station 10) will remain operational.

700.42 ENTERING THE OVERLAY PROGRAMMING MODE

Entry is made by depressing the appropriate parameter button (Station, System, Exception, and CO Line). That LED will remain lit (to indicate which field is being updated) until another parameter is selected. No information is transferred to dynamic memory until the ENTER key is depressed. A solid tone indicates valid data was entered. An interrupted tone means there was an error in data entry.

The following pages give step by step instructions for programming each parameter using the appropriate overlay. Examples of the overlays, Figures 7.7 through 7.10 are also included for reference purposes.

700.50 SYSTEM PARAMETERS

Upon entry into the system parameters overlay, the current data (default or programmed) is displayed. In the case of yes-no values, a lit LED indicates a yes value. By depressing the button associated with the entry, the LED will toggle between off and on. It is not necessary to press the 'Enter' button after changing a yes-no value within a parameter. All yes-no values may be selected and then the 'Enter' button pressed once to enter the data.

Where numeric data is required, the button is depressed and the data is entered on the numeric key pad. Exceeding the correct number of digits will cause an error tone when the 'ENTER' button is depressed. System timers can be deactivated by entering zeros for the timer values.

After each numeric data entry, the 'Enter' button must be depressed. If confirmation is received, proceed to the next data field within the system parameters.

700.51 SELECTIONS – SYSTEM PARAMETERS

1. **Exclusive Hold Recall:** This entry reflects the time elapsed before a call placed on exclusive hold will recall the station activating this feature. If unanswered for the same elapsed time, this call will then ring the attendant. The default value is set at 060 seconds and is variable from 001 to 255 seconds.

The entry format requires three (3) digits. This timer can be deactivated by entering '000' as the timer value.

2. **Transfer Recall:** This entry reflects the time elapsed before an unanswered call transfer is recalled to the station that initiated the transfer. If unanswered for the same elapsed time, this call will then ring the attendant. The default value is set at 060 seconds and is variable from 001 to 255 seconds.

The entry format requires three (3) digits. This timer can be deactivated by entering '000' as the timer value.

3. **System Hold Recall:** This entry reflects the time elapsed before an unanswered system hold is recalled to the station that initiated the hold. If unanswered for the same elapsed time, this call will then ring the attendant. The default value is set at 600 seconds and is variable from 001 to 600 seconds.

The entry format requires three (3) digits. This timer can be deactivated by entering 000 as the timer value.

4. **Flash Timer:** This timer reflects the duration of a simulated hookswitch flash. This feature has particular applications when the NC-1648 is interfaced with an EPABX. The default value is two (2) seconds and is variable from 0.1 to 9.9 seconds.

Two (2) digit entries are made allowing increments of 1/10 of a second (i.e. 15 equals

1.5 seconds). References to the min/max values of the associated EPABX should be made when setting this timer.

5. **Paging Time-Out:** This timer determines the amount of time all paging circuits will stay seized. This includes both internal and external zones. When setting this timer, the maximum length of a page should be considered. The default value is set at 60 seconds and is variable from 01-99 seconds.

This entry format requires two (2) digits. This timer can be deactivated by entering '000' as the timer value.

6. **Conference Time-Out:** This timer reflects the amount of time the conference circuit will remain active if the initiator of the conference is no longer in the circuit. A warning tone will be presented to the remaining users 15 seconds prior to shutdown. A warning tone and flashing conference button will warn the conference controller 30 seconds prior to shutdown. The default value is set at 99 minutes and is variable between 001 and 099 minutes. The timeout clock is automatically reset to zero whenever the conference initiator re-enters the conference.

The entry format requires a three (3) digit entry. This timer can be deactivated by entering '000' as the timer value.

7. **Hunt Groups:** The system can be programmed for up to six (6) hunt groups of up to eight (8) stations each. The hunt groups are circular in nature and search the entire group regardless of the entry point. When an intercom or transferred CO line to a station in a hunt group receives a busy, the system will search sequentially for an idle station. It will then ring that idle station. A station in Call Forward will receive the ring at the forwarded station. If all stations in a hunt group are busy, the calling station can camp-on to the original busy station. The same station may not be in more than one group.

By default no stations are assigned to a hunt group. Depress Hunt Group Number, then enter the 2 digit station numbers on the numeric pad one right after another up to a maximum of 8 stations. When all stations in a hunt group have been entered, depress the ENTER button. To clear a hunt group, depress Hunt Group number, then the INIT button.

8. **Diagnostic Start Time:** This entry is the actual time (24 hour format) that on-line diagnostics will begin. The default value is set at 2525 hours. This invalid time effectively disables on-line diagnostics.
Entries can vary from 0000 to 2359.
To enter depress DIAG TIME button.
Then enter a four (4) digit number to indicate time diagnostics will begin.
9. **Preset Forward Timer:** This entry works with Preset Forward (station parameters). The timer starts when a CO line begins to ring in. If the line is answered prior to expiration of the timer, the timer is discontinued. Once the timer has expired, the forwarded station will ring until answered or disconnected by the calling party.
The default value is set at 20 seconds and is variable from 01 to 40 seconds. The entry format requires a 2 digit entry.
10. **External Night Ring:** This entry when set at 'YES' activates the external night ring feature. When the CO line UNA feature is also set to 'YES', tone will be output to both external paging ports when an incoming call occurs on that line during night mode operation.
By default this entry is set at 'NO' (LED off). To activate depress EXNITE RING button so that LED lights up.
11. **Attendant Override:** This entry when set at 'YES' activates the attendant override feature, allowing DND override tone and CO line delayed barge-in at both DSS positions.
By default this entry is set at 'NO' (LED off). To activate depress ATO OVRD button so that LED lights up.
12. **Loud Bell Control:** Setting this entry to DAY & NIGHT and setting the individual CO line UNA to 'YES' allows external bell control in both day and night mode.
Setting this entry to NIGHT and setting the individual CO line UNA to 'YES' allows external bell control in the night mode only.
When connected, the LBC contact closure will provide an interrupted sequence of one second on (closed) and four (4) seconds off (open).
By default this entry is set to NIGHT (LED off). To change entry to Day & Night, depress LBC button so it lights up.
13. **Baud Rate Select:** This entry controls the baud rate of the printer output. F=fast or 1300 baud. S=slow or 300 baud. The default setting for this entry is 300 baud. When displayed on the DSS Console, the LED will be lit for 300 baud and extinguished for 1200 baud. The BAUDRATE LED should be OFF (1200 baud) for proper mini-printer operation.
14. **Hour Format:** This controls the display format of the time. The standard display of system time is HH:MM which is the default setting (LED off). To change the hour range of 12 through 11 to 00 through 24, depress the 24 HR button so the LED lights up.
15. **Month/Day Format:** This controls the display format of the date. The standard display of system date is MM/DD/YY which is the default setting (LED off). To reverse the display to DD/MM/YY, depress the DD/MM button so the LED lights up.
16. **Last Number Redial – Single Lines:** This entry allows single line telephones to have the ability to automatically redial the last number dialed. By default this entry is enabled (LED on). To deny SLT's the ability to last number redial, depress the LNR-SLT button so the LED extinguishes.
17. **LCD Display:** If display phones are not used in the system, this option can be turned off to improve system performance and speed up communications processing time.
By default this option is enabled (LED on).
18. **SMDR:** This entry allows selection of the type of calls that will be provided by SMDR. A YES entry means that all calls, both incoming and outgoing, local and long distance, will be recorded. A NO entry means that only outgoing calls that have a 0 or 1 as the first or second digit dialed or any number dialed that contains more than 9 digits will be recorded.
The default value is the (LED on), all calls will be recorded.

19. **PBX Codes:** The system will allow five (5) 1 and 2 digit PBX access codes to be entered into memory. When dialed, these codes signal the system that a PBX access code is being dialed. Toll restriction will apply at the next dialed digit. If one of the codes is not dialed, toll restriction does not apply. This allows the dialing of PBX extensions 100, 110, 111, etc.

To enter these codes, depress PBX CODE button and then enter 2 digit code numbers one right after the other. Then press ENTER. A one digit entry should be followed by the STOP button. STOP means that only the one digit code will be used. DON'T CARE means the code will be 2 digit but the second digit can be any number (i.e. 7 plus Don't Care means that 71, 72, 73, etc. can be dialed as the access code).

NOTE: For these codes to work, CO lines must be marked as PBX in CO Line programming (Section 700.06)

700.52 SELECTION ENTRY – SYSTEM PARAMETERS

The following steps should be taken when programming the system parameters.
(See Figure 7.7)

- A. Place system parameters overlay on the DSS console.
- B. Depress the SYS PARAM button.
- C. Select the desired data field (depress button of timer or feature to be programmed).
- D. Enter the desired timer value if required or access the desired feature by depressing that button. Refer to Customer Data Base Sheets for the correct programming format.
- E. Depress the ENTER button. Validation tone should be heard. If interrupted (error) tone is heard, repeat from step C.
- F. To continue, repeat from step C.
- G. To enter Hunt Groups, depress Hunt Group number. Then enter the 2 digit station numbers, one right after another up to 8 stations (16 digits).
- H. Depress ENTER button.
- I. To display entries, depress the STA PARAM button and the DISPLAY TEMP button. The contents of the temporary memory for that

overlay will be printed on an external device or displayed on the DSS through the display procedure.

- J. When all entries have been entered/displayed, select the next overlay or refer to Permanent Update Procedures (Sec. 700.10).

700.60 CO LINE DATA

The CO Line Display contains all data base information necessary to program CO/PBX lines into the 1648 system. The following is a brief description of the items required for entry (See Figure 7.2).

1. **Group:** Eight (8) groups are available for CO line assignment. Groups should be assigned according to trunk type (i.e. local WATS, FX, etc.). For valid trunks, groups 1-7 are available for use. Any uninstalled trunk should be removed from all line groups by placing it in group '0'.
2. **Class of Service:** There are five (5) possible classes of service that can be assigned to a CO line which can alter a station's normal class of service. They are:

Class 0 – Unrestricted, station class of service has priority.

Class 1 – ALLOW/DENY Table 1 is applied.

Class 2 – ALLOW/DENY Table 2 is applied.

Class 3 – Restricts 0/1/*/# as first dialed digit and does not allow dialing of over 7 digits.

Class 4 – Overrides station class of service 0-4.

Enter the COS desired for each CO line on the data base form. Under default data all lines are given COS 0.

The following rules should be remembered when determining CO line class of service: (Table 7-3)

- a. Station class of service 5 is not affected by any CO Line class of service.
- b. When CO Line COS 4 is assigned, it has priority over station COS 1, 2, 3 & 4.
- c. When CO Line COS 3 is assigned, it has priority over station COS 0, 1, 2, & 3.
- d. When CO Line COS 0 is assigned, only station COS applies. In general, station COS 3 with CO COS 0 is one large table combining tables 1 & 2.
- e. When CO Line COS 1 is assigned, only station COS 1 & 3 are affected, and only when there are entries in Table 1.

**TABLE 7-2
CO LINE CLASS OF SERVICE**

STATION		COS 0	COS 1	COS 2	COS 3	COS 4
	COS 0	Unrestricted	Unrestricted	Unrestricted	Restricts 0/1, #, * & over 7 digits	Unrestricted
	COS 1	Table 1 Governs	Table 1 Governs	Unrestricted Not Governed by Table 1	Restricts 0/1, #, * & over 7 digits	Unrestricted
	COS 2	Table 2 Governs	Unrestricted Not Governed by Table 2	Table 2 Governs	Restricts 0/1, #, * & over 7 digits	Unrestricted
	COS 3	Tables 1 & 2 Govern	Table 1 Governs	Table 2 Governs	Restricts 0/1, #, * & over 7 digits	Unrestricted
	COS 4	Restricts 0/1, #, * & over 7 digits	Restricts 0/1, #, * & over 7 digits	Restricts 0/1, #, * & over 7 digits	Restricts 0/1, #, * & over 7 digits	Unrestricted
	COS 5	In house only	In house only	In house only	In house only	In house only

* A station's normal class of service restrictions can be altered depending on the class of service applied to the CO line being used.

CO LINE CLASS OF SERVICE

Class 0 – Unrestricted, station COS has priority.

Class 1 – Table 1 is applied.

Class 2 – Table 2 is applied.

Class 3 – Restricts 0/1 as first dialed digit & over 7 digits.

Class 4 – Overrides station COS 0-4.

Class 5 –

STATION CLASS OF SERVICE

Unrestricted use of long distance, local & intercom dialing digits.

The first 8 dialed digits are compared to ALLOW/DENY 1 tables for violation checks. Intercom numbers are allowed.

The first 8 dialed digits are compared to ALLOW/DENY 2 tables for violation checks. Intercom numbers are allowed.

The first 8 dialed digits are compared to ALLOW/DENY 1 & 2 tables for violation checks. Intercom numbers are allowed.

Seven (7) digit local area dialing & intercom numbers allowed only. No 0 or 1.

Intercom calls only.

**TABLE 7-3
CO LINE CLASS OF SERVICE**

- f. When CO Line COS 2 is assigned, only station COS 2 & 3 are affected, and only when there are entries in Table 2.
3. **CO/PBX Line:** This entry defines the CO line type. The types available are CO line or PBX. When marked PBX, a two (2) digit dialing code may be used (see system parameters programming), after which toll restriction applies to the next dialed digit. By default all entries are assigned as CO lines (LED off).
4. **Day Ring Station Number:** Up to forty-eight (48) key telephones can be assigned to ring on each CO line.
5. **Night Ring Station Number:** Up to forty-eight (48) key telephones can be assigned to ring on each CO line. These can be the same as or different from the key telephones programmed to ring during the day.
6. **UNA:** A 'YES' entry allows night service answering of incoming CO/PBX calls on UNA assigned lines from single line telephones. Key telephones not normally assigned access to the CO lines because of line group access restrictions can answer the specified CO lines by direct button access.
7. **Pulse:** This field determines the signalling method used by the CO line. A 'YES' entry indicates dial pulse signalling. A 'NO' entry indicates DTMF (Tone) signalling. The proper KTU card (COB-P or COB-T) must be installed to match the entry.
- E. Depress LINE COS button if the line COS is to be changed. On the numeric key pad, the number of the assigned COS will be flashing. To change depress the number of the COS to be assigned. That number will start flashing.
- F. Depress ENTER button. Validation tone should be heard. If error tone is heard, repeat process.
- G. Depress the CO/PBX button if the line is to be a PBX line. Default value is CO line and the LED is OFF.
- H. Depress STATION RING – DAY if required. Enter desired key station numbers for day mode operation on the numeric keypad. All entries should be made consecutively (i.e. enter 10, 11, 12, 13 to program stations 10, 11, 12, 13 to ring during the day). Station 10 is preassigned (default) as one of the stations. If an additional entry is required, station 10 must be re-entered.
- I. Depress ENTER button. Validation tone should be heard. If error tone is heard, repeat process.
- J. Depress STATION RING – NIGHT if required. Enter desired key station numbers for night mode operation the same as for day ringing stations. Stations assigned with this function will only ring at night. Station 10 is assigned by default.
- K. Depress ENTER button. Validation tone should be heard. If error tone is encountered, repeat process.
- L. Depress UNA if not required. The default value is yes and LED is ON.
- M. Depress PULSE button if this line requires outpulsing to the Central Office facilities. The default value for this feature is Tone and the LED is off. If outpulsing is required, a COB-P must be equipped in the NORTHCOM 1648 Key System.
- N. Press ENTER button.
- O. To program additional CO lines, go to item C and repeat. If an error is made during program entry, return to invalid item and re-enter.
- P. To check all entries, depress DISP TEMP and the contents of the temporary memory for that overlay will be printed on an external device or displayed on the DSS through the display procedure.

700.61 CO LINE DATA BASE ENTRY

Refer to the Customer Data Base Sheets and Figure 7.8 for the correct programming information.

All default data will be illuminated upon entry to this parameter. In the case of yes/no values, continued depression of the applicable button will cause the LED to toggle between on and off.

- A. Place the CO Line Overlay on the DSS Console.
- B. Depress the CO ATTRIB button.
- C. Depress desired CO Line button.
- D. Depress desired CO LINE GROUP button.
A line can be assigned to one line group only.

- Q. When all CO lines have been entered/displayed, select the next overlay or refer to Permanent Update Procedures.

700.70 STATION DATA

The Station Overlay contains all data base information necessary to program each individual station into the 1648 system. The following is a brief description of the items required for entry. (See Figure 7.3)

1. **Class of Service (COS):** Governs a stations restriction. When assigned a COS, different degrees of toll restriction can be applied. There are six (6) classes of service available and they are defined as follows:
 - Class 0 – Unrestricted usage of long distance, local and intercom dialing digits.
 - Class 1 – The first eight (8) dialed digits are compared to ALLOW/DENY Table 1 for violation checks. Intercom numbers are allowed.
 - Class 2 – The first eight (8) dialed digits are compared to ALLOW/DENY Table 2 for violation checks. Intercom numbers are allowed.
 - Class 3 – The first eight (8) dialed digits are compared to ALLOW/DENY Table 1 and Table 2 for violation checks. Intercom numbers are allowed.
 - Class 4 – Seven (7) digit local area dialing and intercom numbers only are allowed. No 0/1/*/# as the first dialed digit.
 - Class 5 – Only intercom numbers are allowed.

Enter the COS desired for each station on the data base form. Under default data, all stations are given COS 0.
2. **Page/Pickup Zone:** Enter the assigned intercom page zones for each key telephone. Users may receive all zones or, by not assigning any zone, be restricted from receiving any paging announcements. This entry reflects which key telephone will be paged when the Zone or All Call feature is used.
3. **CO Line Group:** Enter the line group(s) each station is allowed to access. CO line groups were established on the CO Line Overlay sheet.

Key telephones not allowed access to CO lines will not receive an LED indication of the line's status.

4. **System Speed:** A YES entry indicates that this station is allowed the system speed dial feature. Toll restriction does not apply to system speed numbers in bins 10-45. System speed numbers in bins 50-89 are subject to class of service assignments of the station originating the call.
5. **DND:** A YES entry indicates that this station is allowed the Do-Not-Disturb feature.
6. **Station Call Forwarding:** A station allowed this feature can have intercom and transferred CO lines forwarded to another station. A forwarded call will signal the receiving station in the TONE mode regardless of the intercom signalling switch position. A YES entry indicates that this station is allowed to call forward.
7. **Preset Call Forward:** The system may be programmed so that ringing CO lines can be forwarded to another predetermined station if the original station is busy or does not answer. CO lines programmed to ring at a designated station will ring for a programmable period (see system parameters). During this time period, the busy station will hear muted (CAMP-ON) ringing. CO lines not answered during that time period will be forwarded to the predetermined station. The same preset forward number may be assigned to more than one station.

700.71 STATION DATA BASE ENTRY

The following steps should be followed when programming station lines. Refer to the Customer Data Base sheets and Figure 7.9 for the correct programming information.

- A. Place the Station Overlay on the DSS Console.
- B. Depress the STA ATTRIB button.
- C. Depress the STA NUM button.
- D. Enter the desired station number via the DSS keypad. Upon entry, the ten's digit will be lit steady and the units digit will flash to signify which station is being programmed. Only a steady light is visible, both digits are identical.
- E. Depress the appropriate CLASS OF SERVICE button.

- F. Depress the desired PAGE/PICKUP button(s). A station user can be in more than one zone. Subsequent depression of these buttons will have a toggle effect and will allow/deny paging announcements on a particular zone.
- G. Depress the desired CO LINE GROUP button. A station user can have access to any variety of CO line groups. Subsequent depression of these buttons will have a toggle effect and will allow/deny access to a particular group. If the station was assigned to ring for a particular CO line in the CO overlay program, this station must be assigned access to the associated CO line group in order to answer the ringing line during day mode operation. Refer to UNA for night mode operation.
- H. Depress the SYS SPD button if access to system numbers is not allowed. Since the default value for this feature is ALLOW, the LED will be illuminated upon entry. Therefore, a depression of this button will extinguish this LED thus denying this feature.
- I. Depress the DND button if this feature is not desired. Since the default value for this feature is ALLOW, the LED will be illuminated upon entry to this mode for the station being programmed. Therefore, a depression of this button will extinguish the LED, thus denying this feature.
- J. If the station is to have the ability to forward transferred CO line calls or intercom calls to another station, the STA FWD button should be lit. To deny this ability, depress that button so the LED extinguishes.
- K. If the station is assigned incoming CO line ringing and is to have those calls forwarded to a predetermined station, depress PRE FWD button. Then depress the number of the station to receive the forward on the overlay keypad. The ten's digit will light steady and the units digit will flash. This entry works with Preset Forward Timer (system parameters).
- L. Depress the ENTER button.
- M. If further stations are to be programmed, the NEXT button may be pressed to program the next station in sequence and continue from step E. If stations are not being programmed in sequence, go back to step D.

- N. To display all entries, depress the STA ATTRIB button and the DISP TEMP button, and the contents of the temporary memory for this overlay will be displayed (Refer to Section 7.11).
- O. When all station lines have been entered/displayed, select the next overlay or refer to Permanent Update Procedures (Section 700.10).

700.80 EXCEPTION TABLE DATA

The ALLOW/DENY tables are organized into two set of tables to allow the NORTHCOM 1648 system to support two different toll plans at one installed site. Allow/Deny table 1 is referenced whenever a station is assigned Class of Service 1 and Allow/Deny table 2 is referenced whenever a station is assigned Class of Service 2 (Refer to Figure 7.5, Use Table 7-4 for reference).

The system provides two allow tables and two deny tables. The allow tables may contain up to 20 entries (8 digits in length), and the deny tables may contain up to 10 entries (8 digits in length). Any number of digits up to 8 maximum may be entered. The Don't Care entry (depressing the DON'T CARE button) counts as a digit.

Less than 8 digits may be entered. For example, the installer needs only to dial '0' and press ENTER to program the 8 digit field for operator restriction.

**TABLE 7-4
ALLOW/DENY TOLL TABLES**

	ALLOW TABLE	DENY TABLE	CONDITIONS AND RESULTS			
			DIALED NO.	A/D	DIALED NO.	A/D
RULE 1	NO ENTRIES	NO ENTRIES	ALLOW			
RULE 2	ENTRIES	NO ENTRIES	FOUND	A		
			NOT FOUND	D		
RULE 3	NO ENTRIES	ENTRIES			FOUND	D
					NOT FOUND	A
RULE 4	ENTRIES	ENTRIES	FOUND	A		
			NOT FOUND	D		
			ALLOW TABLE	DENY TABLE		

The following rules should be remembered when setting up the Exception Tables.

- Rule 1. If there are no entries in the Allow or Deny Tables, then any number dialed will be allowed.
- Rule 2. If an entry is made in the Allow Table only, the COS restriction is to 'allow only' those dialed numbers that match the programmed entry in the Allow Table. Any number not found in the Allow Table, will be denied.
- Rule 3. If an entry is made in the Deny Table only, the COS restriction is to 'deny only' the numbers in the Deny Table. Any number not found in the Deny Table will be allowed.
- Rule 4. If entries are made in both Allow and Deny Tables, the sequence is as follows: search the Allow Tables, if the dialed number is found, the call is allowed. If it is not found, the Deny Table is searched. If the number is found in the Deny Table, then it is denied. If it is not found in the Deny Table, it is allowed.

The ALLOW ONE/DENY ONE and ALLOW TWO/DENY TWO Tables are reserved for COS 1 and COS 2 respectively.

700.81 EXCEPTION TABLE DATA BASE ENTRY

The following steps should be followed when programming Exception Table entries. Refer to the Customer Data Base sheets and Figure 7.10 for correct programming information.

- A. Place Exception Tables Overlay on the DSS Console.
- B. Depress the EXCEPT ATRIB button (button lights). PAGE 1 button will also light.
- C. Depress the desired Allow/Deny bin location (button will light).
- D. Enter the exception number on the numeric key pad.
- E. Press the ENTER button (validation tone is heard).
- F. Select the next bin location. If the information is to be entered into bins 11-20 in the Allow Table and 6-10 in the Deny Table, press the PAGE 2 button, then press the desired bin location.

- G. Return to Page 1 by pressing PAGE 1 button and repeat steps C through G for programming additional tables.
- H. When all Allow/Deny numbers have been entered, select another Overlay or update information into Permanent Memory.

700.90 PERMANENT UPDATE PROCEDURES

The following procedures should be followed to permanently store all data base entries into memory.

- A. Depress the UPDATE PERM button on the DSS console.
- B. Depress program switch on underside of DSS console.

Customer data has now been stored.

The DSS console has been restored to normal service. Make sure DIP switch 8 on the CPB PCB is OFF to ensure data base protection.

700.100 DISPLAY PROCEDURES

The NORTHCOM 1648 provides (through the Mini-Printer, the RS-232C connector, or DSS button illumination) a status of the temporary or permanent data base. The following is a detailed procedure for obtaining this information.

700.101 HARD COPY PRINTOUT

In order to obtain a hard copy printout of the present data base, a compatible listing device can be connected to the RS-232C connector. Or the optional NC-1648 Mini-Printer may be utilized for data base printout. Refer to Figure 5.18 for proper cabling connections.

Changes made prior to the UPDATE PERM procedure can be displayed by depressing the DISP TEMP button. This will ensure that the changes were made correctly prior to permanent update.

Proceed with the following instructions:

- A. Enter the program mode.
- B. Depress desired overlay button.
- C. Depress DISP TEMP button.
The entire data base contents for the selected overlay will be displayed on the listing device.

To see how the system was previously programmed, the DISPLAY TEMP button can be pressed while the programmer is in the middle of programming a parameter – DO NOT press the Enter button.

Pressing the MODE button will stop the printing at any point in the printing process.

Figure 7.14 through 7.18 are examples of a typical system data base printout.

System speed numbers can be displayed by entering the System Parameters overlay and depressing the SPD (DISP) button. Then depress the DISP PERM button. All bins programmed with a speed number will print, followed by a list of all empty bins. To display just one bin, depress the SPD (DISP) button, followed by the bin number, and then the DISP PERM button.

700.102 DATA BASE DISPLAY WITHOUT A LISTING DEVICE

Temporary and permanent data bases can be displayed by observing the status of the LED's on the DSS console.

Upon entering a particular parameter, permanent data is copied in the temporary (dynamic) area. Refer to Figure 7.11. At that point, the contents of the temporary & permanent areas will be the same. Only when changes have been made prior to a permanent update will they differ.

Because each overlay displays differently, each is outlined below.

700.103 SYSTEM PARAMETERS DISPLAY

1. Depress SYS PARAM button.
2. Depress desired timer button (that button flashes).
3. Depress either DISP TEMP or DISP PERM button (MODE button will light). The first digit of the timer value will be displayed on the appropriate dial pad LED.
4. For subsequent digits, continue to depress the timer button and observe which LED's light. When all digits have been displayed, continued depression will result in error tone.
5. To display other timer values, repeat steps 2 through 4.

6. Yes/no values will be displayed by the associate button LED being lit or unlit.
7. Upon entering the system overlay, LED's will be lit for those hunt groups with stations assigned.
 - a. Depress the desired hunt group number and the first station will be displayed. The ten's digit will light steady and the units digit will flash.
 - b. Subsequent depressions will display the rest of the stations in that hunt group.
 - c. When all stations have been displayed, error tone will be heard.
8. IF PBX codes have been assigned, the PBX CODE button will be illuminated. If already in the display mode, depress the PBX CODE button. That LED will flash and the first digit of the PBX code number will be displayed on the numeric keypad. Continued depressions will display subsequent digits. All PBX codes will have 2 digits. For a one digit code, the STOP button will flash as the 2nd digit.
9. When all data fields have been displayed, continue displaying other parameters or make desired changes or exit programming.

700.104 CO LINE DATA DISPLAY

1. Depress the CO ATTRIB button.
2. Depress the desired CO line button. All data for the selected line will be displayed, except ring assignments and class of service. As soon as new data is programmed, that data is displayed. To see what was previously programmed, press DISP PERM button.
3. Ring assignments are displayed as follows:
 - a. Depress the DAY or NIGHT ring button.
 - b. Depress either TEMP or PERM button. The first station of the assigned stations will display on the keypad. The ten's digit will light steady & the units digit will flash.
 - c. Subsequent depressions of the DAY or NIGHT button will display the remaining assigned stations.
 - d. Error tone will be heard when all stations have been displayed.

4. CO line class of service is displayed as follows:
 - a. Depress LINE COS button.
 - b. The assigned COS number for that CO line will flash on the numeric key pad.
5. To continue displaying CO line data, depress the desired CO line button and that line will be displayed.
6. When all CO lines have been displayed, continue displaying other parameters or make desired changes or exit programming.

700.105 STATION DATA DISPLAY

1. Depress the STA ATTRIB button.
2. Depress the STA NUM button.
3. Dial selected station number on DSS dial pad. The ten's digit will light steady and the units digit will flash for the selected station number.
4. Associated data for the selected station will be indicated by illuminated LED's. Prior to PERM UPDATE temporary data will be displayed. To see what was programmed previously, press the DISP PERM button. After doing a display perm procedure, depress the MODE button to return to displaying other stations.
5. If the selected station has been programmed to forward to another predetermined station when busy or not answering. The PRE FWD button will be lit. To determine the forwarded to station, depress the PRE FWD button. All other LED's will extinguish and the station number will be lit on the dial pad. The tens digit will light steady & the units digit will flash. Depress the PRE FWD button again to go back to station display.
6. To display the data for the next station, depress the station number on the numeric key pad.
7. When all desired stations have been displayed, continue displaying other parameters or make desired changes or exit programming.

700.106 SPEED DIAL DATA DISPLAY

System speed dial numbers cannot be displayed without a printer or a display phone.

700.107 EXCEPTION TABLE DATA DISPLAY

1. Depress EXCEPT ATTRIB button.
2. Depress the desired bin location (if bin location is on Page 2, depress the PAGE 2 button first, then the bin location button).
3. Depress either the TEMP button for display of temporary data, or the PERM button for display of permanent data.
4. Depress the selected bin location again. The first digit will then display on the numeric keypad. Continued depressions will display subsequent digits. When all digits have been displayed, continued depression will result in error tone.
5. To display another bin, depress that bin location. The first digit will be displayed on the numeric keypad. Continued depressions will display subsequent digits.
6. When all desired bin locations have been displayed, make changes as desired. To continue programming, select another overlay. To terminate the unit from the programming mode, depress UPDATE/PERM button and press the recessed data switch on the underside of the DSS console. This returns the DSS to normal operation.

700.110 ATTENDANT SPECIAL PROGRAMMING

This section describes attendant programming of system speed dial numbers and setting of the system date and time through the attendant's keyset telephone.

700.111 PROGRAMMING SYSTEM SPEED DIAL NUMBERS

The following steps should be taken when programming system speed dial numbers from the attendant's station (10). There are 76 system speed dial numbers of up to 24 digits each.

- A. At station 10, lift handset or press ON/OFF button.
- B. Press the asterisk (*) key twice.
- C. Dial the two digit location code (10-45, 50-89) on the dial pad.

- D. Dial the complete telephone number, including pauses. Each pause entered will provide 2 seconds of pause in the dialing sequence.
- E. Press the asterisk (*) key twice.
- F. Hang up to complete programming or repeat steps B through E to continue entering additional system speed dial numbers.

NOTE: To program a flash into system speed dial numbers, use the FLASH button.

To program a pause use the PICKUP button. To protect confidential numbers in speed dial memories, the HOLD button may be pressed before entering the telephone number. All digits stored after that will not be displayed and the NO DISPLAY prompt will appear on the LCD.

*The * and the # may be entered as actual digits in speed dial numbers.*

700.112 PROGRAMMING SYSTEM TIME AND DATE

The system date and time are displayed on the NC-1648 LCD Display Phone and must be programmed from the attendant's station keyset (10). The following steps should be taken when programming system date and time.

- A. At station 10, lift handset or press ON/OFF button.
- B. Press the asterisk (*) key twice.
- C. Dial the two digit program code "46" on the dial pad.
- D. Enter the system date and time on the dial pad in the following format:
YY/MM/DD/HH/MM where
YY = last 2 digits of year in the range 80-99
MM = month in the range 01-12
DD = day in the range 01-31
HH = hours in the range 00-23
MM = minutes in the range 00-59
- E. Hang up to complete programming.

PARAMETER	FORMAT	DEFAULT	NEW VALUE
EXCLUSIVE HOLD RECALL	000-255 SEC	060 SEC	
TRANSFER RECALL	000-255 SEC	060 SEC	
SYSTEM HOLD RECALL	000-600 SEC	600 SEC	
FLASH TIMER	0.1-9.9 SEC	2.0 SEC	
PAGING TIME OUT	00-99 SEC	60 SEC	
CONFERENCE TIME OUT	000-090 MIN	090 MIN	
HUNT GROUP 1	UP TO 8 STA	NONE	
HUNG GROUP 2	UP TO 8 STA	NONE	
HUNT GROUP 3	UP TO 8 STA	NONE	
HUNT GROUP 4	UP TO 8 STA	NONE	
HUNT GROUP 5	UP TO 8 STA	NONE	
HUNT GROUP 6	UP TO 8 STA	NONE	
DIAGNOSTIC START TIME	0000-2359	2525	
PRESET FORWARD TIMER	01-40 SEC	20 SEC	
EXTERNAL NIGHT RING	Y/N	N (LED off)	
ATTENDANT OVERRIDE	Y/N	N (LED off)	
BAUD RATE SELECT	S/F (300/1200)	S (LED on)	
HOUR FORMAT	24/12	12 (LED off)	
MONTH/DAY FORMAT	DDMM/MMDD	MMDD (LED off)	
LOUD BELL CONTROL	D/N (DAY & NITE/NITE)	N (LED off)	
LAST NUMBER REDIAL-SLT	Y/N	Y (LED on)	
SMDR	Y/N (ALL. LONG DIST)	Y (LED on)	
LCD DISPLAY	Y/N	Y (LED on)	
PBX CODES	UP TO 5	NONE	

FIGURE 7.1
CUSTOMER DEFINITION SHEET
(SYSTEM PARAMETERS OVERLAY)

TRUNK #	GROUP (0-7)	COS (0-4)	CO/PBX LINE	DAY RING STATION #	NIGHT RING STATION #	UNA (Y/N)	PULSE (Y/N)	REMARKS
CO 01								
CO 02								
CO 03								
CO 04								
CO 05								
CO 06								
CO 07								
CO 08								
CO 09								
CO 10								
CO 11								
CO 12								
CO 13								
CO 14								
CO 15								
CO 16								
01-16	1	0	CO (LED OFF)	10	10	Y	N	DEFAULT

NOTES:

1. A CO/PX LINE MAY ONLY BE IN ONE CO LINE GROUP.

FIGURE 7.2
 CUSTOMER DEFINITION SHEET
 (CO LINE OVERLAY)

STATION #	COS 0-5	PAGE ZONE 0, 1, 2, 3, 4	LINE GROUP 0, 1, 2, 3, 4, 5, 6, 7	SYS SPD Y/N	DND Y/N	STA FWD Y/N	*PRE FWD STA #	REMARKS
10								
11								
12								
13								
14								
15								
16								
17								
18								
19								
20								
21								
22								
23								
24								
25								
26								
27								
28								
29								
30								
31								
32								
33								
34								
35								
36								
37								
38								
39								
40								
41								
42								
43								
44								
45								
46								
47								
48								
49								
50								
51								
52								
53								
54								
55								
56								
57								
10-57	0	1	1	Y	Y	Y	-	DEFAULT

*PRE FWD is for incoming CO ringing only.

FIGURE 7.3
 CUSTOMER DEFINITION SHEET
 (STATION OVERLAY)

BIN #	TELEPHONE NUMBER (MAX 24 DIGITS INCLUDING PAUSES)	
10		52
11		53
12		54
13		55
14		56
15		57
16		58
17		59
18		60
19		61
20		62
21		63
22		64
23		65
24		66
25		67
26		68
27		69
28		70
29		71
30		72
31		73
32		74
33		75
34		76
35		77
36		78
37		79
38		80
39		81
40		82
41		83
42		84
43		85
44		86
45		87
50		88
51		89

FIGURE 7.4
 CUSTOMER DEFINITION SHEET
 (SYSTEM SPEED NUMBERS)

TABLE #	BIN #	NUMBER TO ALLOW/DENY (8 DIGITS MAX)	BIN #	NUMBER TO ALLOW/DENY (8 DIGITS MAX)
	PAGE 1		PAGE 2	
ALLOW 1	1		11	
ALLOW 1	2		12	
ALLOW 1	3		13	
ALLOW 1	4		14	
ALLOW 1	5		15	
ALLOW 1	6		16	
ALLOW 1	7		17	
ALLOW 1	8		18	
ALLOW 1	9		19	
ALLOW 1	10		20	
DENY 1	1		6	
DENY 1	2		7	
DENY 1	3		8	
DENY 1	4		9	
DENY 1	5		10	
ALLOW 2	1		11	
ALLOW 2	2		12	
ALLOW 2	3		13	
ALLOW 2	4		14	
ALLOW 2	5		15	
ALLOW 2	6		16	
ALLOW 2	7		17	
ALLOW 2	8		18	
ALLOW 2	9		19	
ALLOW 2	10		20	
DENY 2	1		6	
DENY 2	2		7	
DENY 2	3		8	
DENY 2	4		9	
DENY 2	5		10	

FIGURE 7.5
 CUSTOMER DEFINITION SHEET
 (EXCEPTION TABLE OVERLAY)

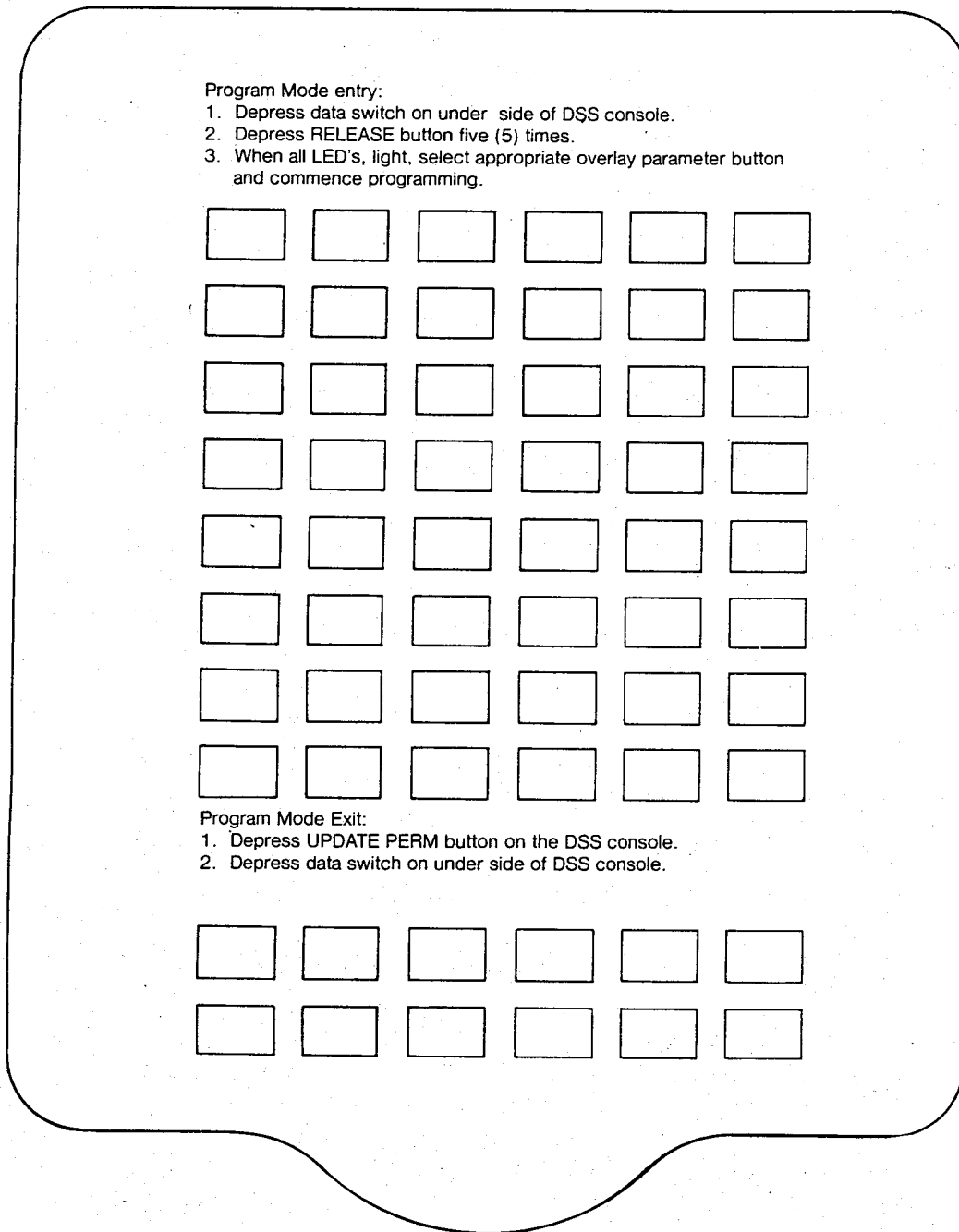

FIGURE 7.6
INSTRUCTION OVERLAY

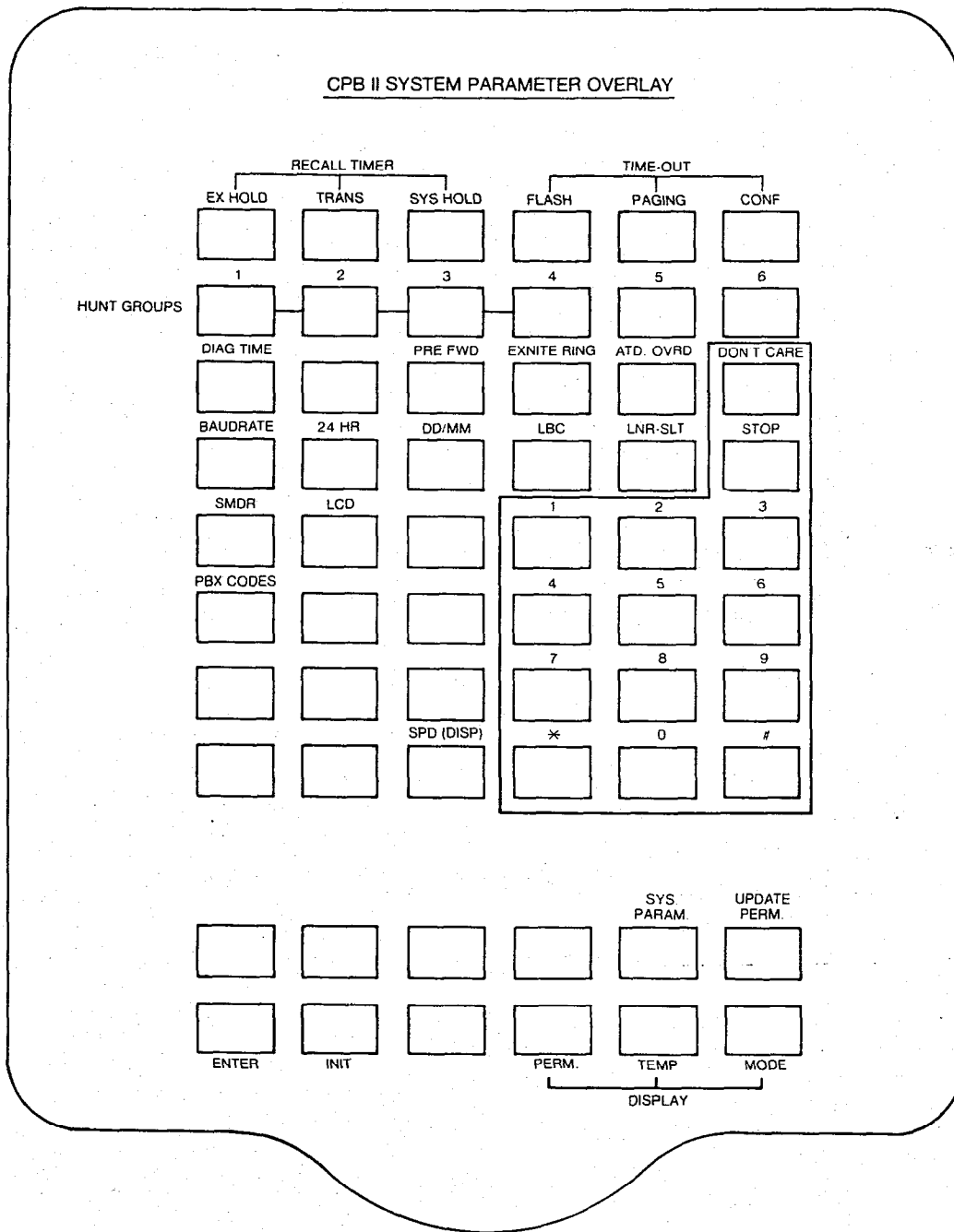

FIGURE 7.7
SYSTEM PARAMETER OVERLAY

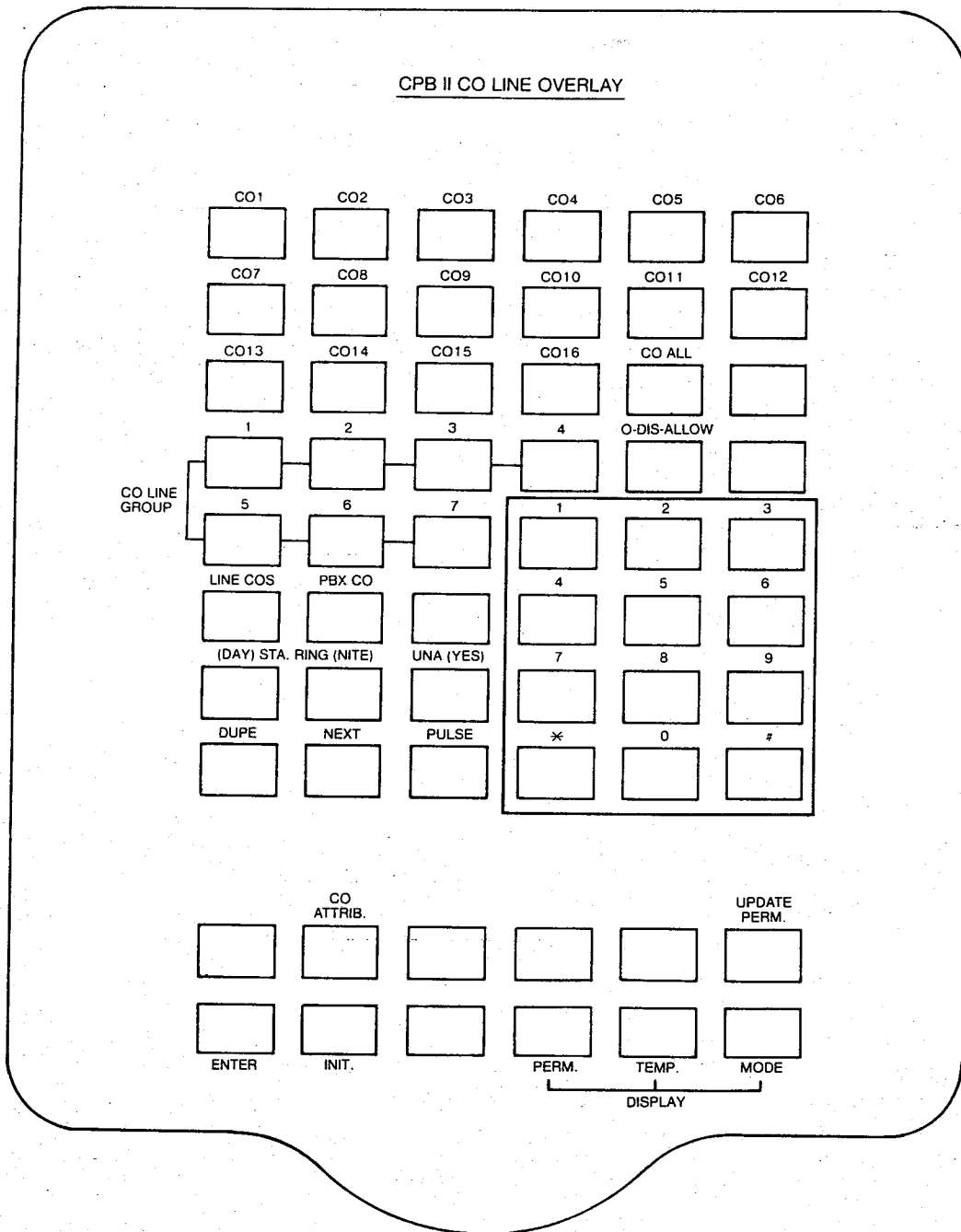
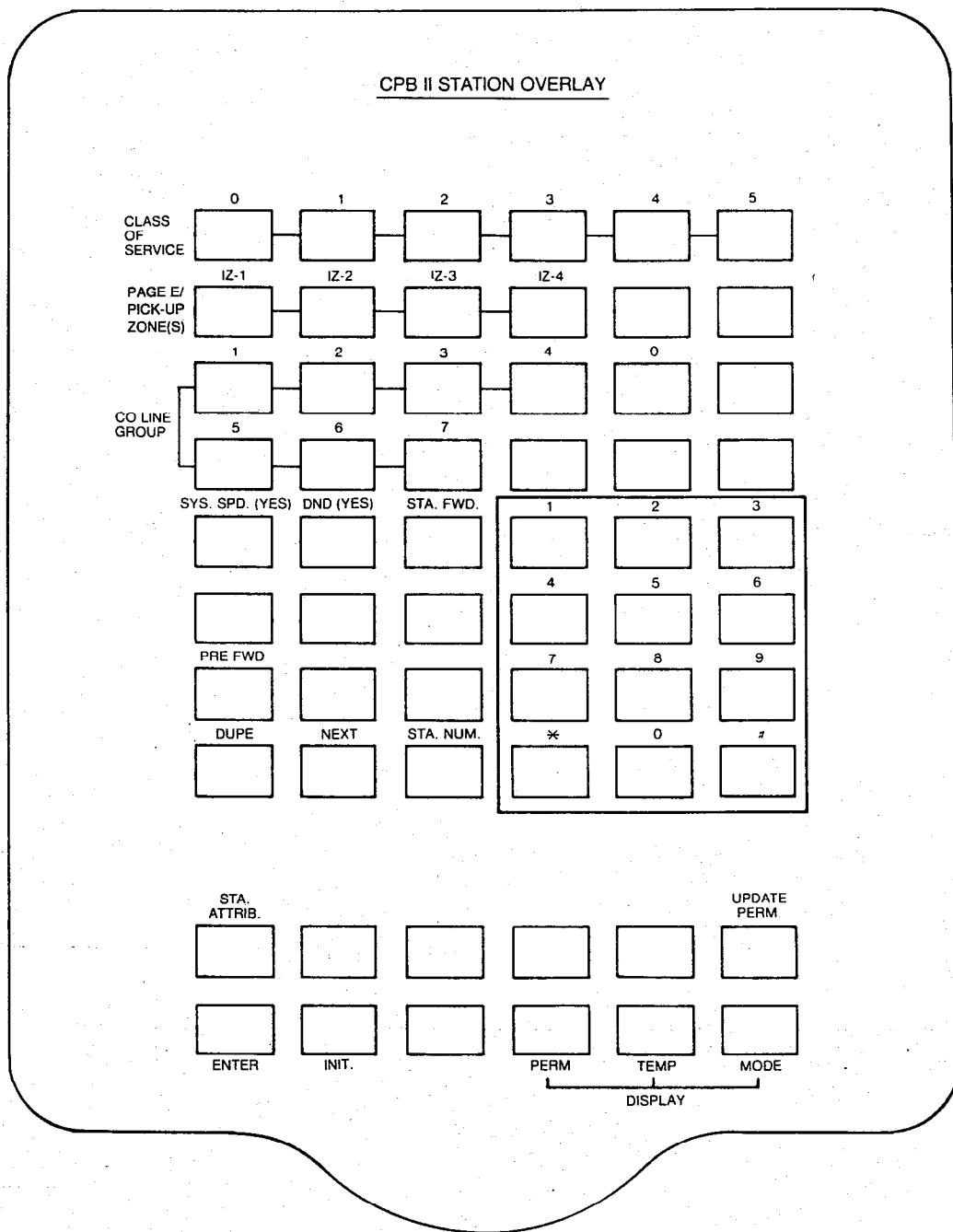

FIGURE 7.8
CO LINE OVERLAY



**FIGURE 7.9
STATION OVERLAY**

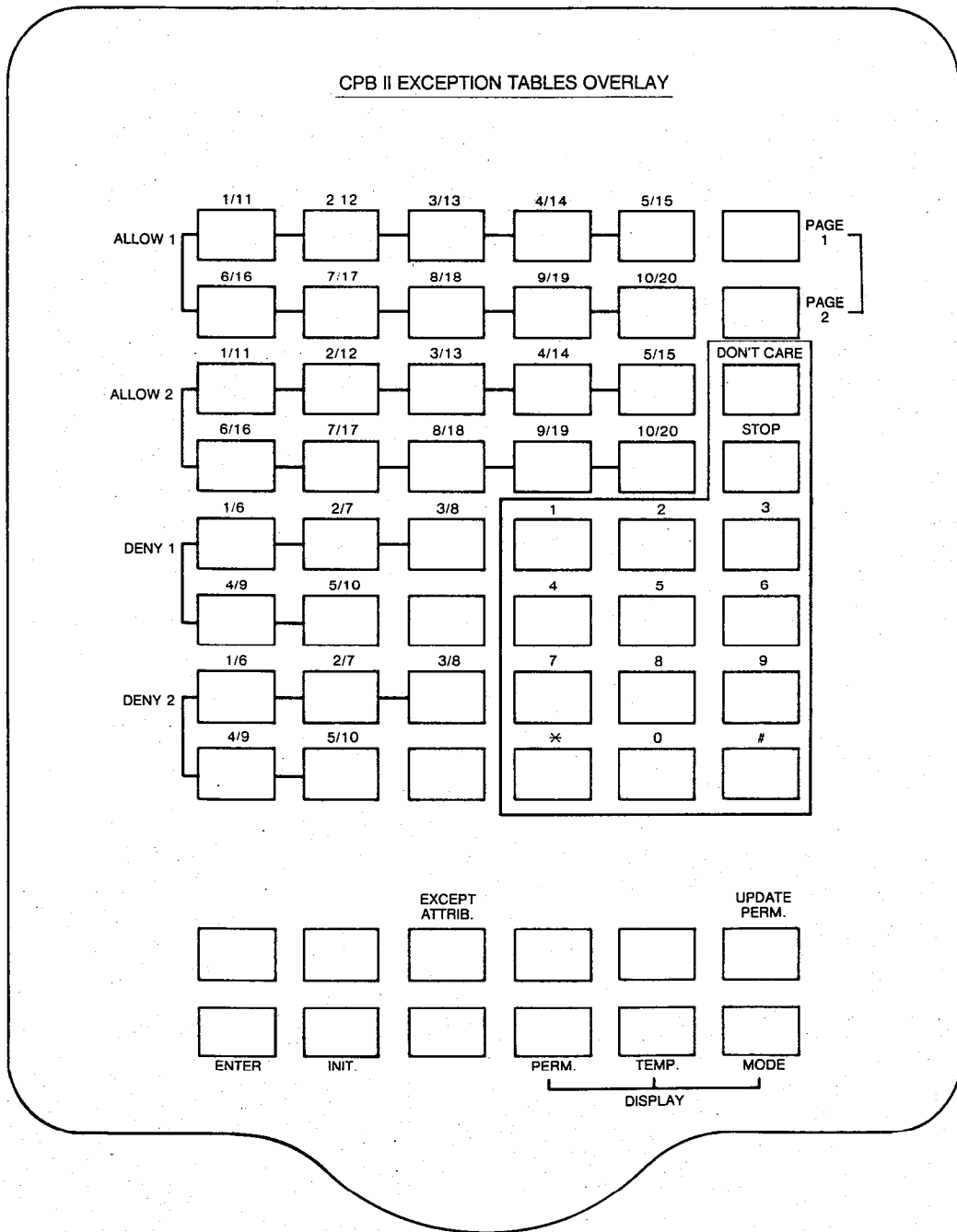

FIGURE 7.10
EXCEPTION TABLES OVERLAY

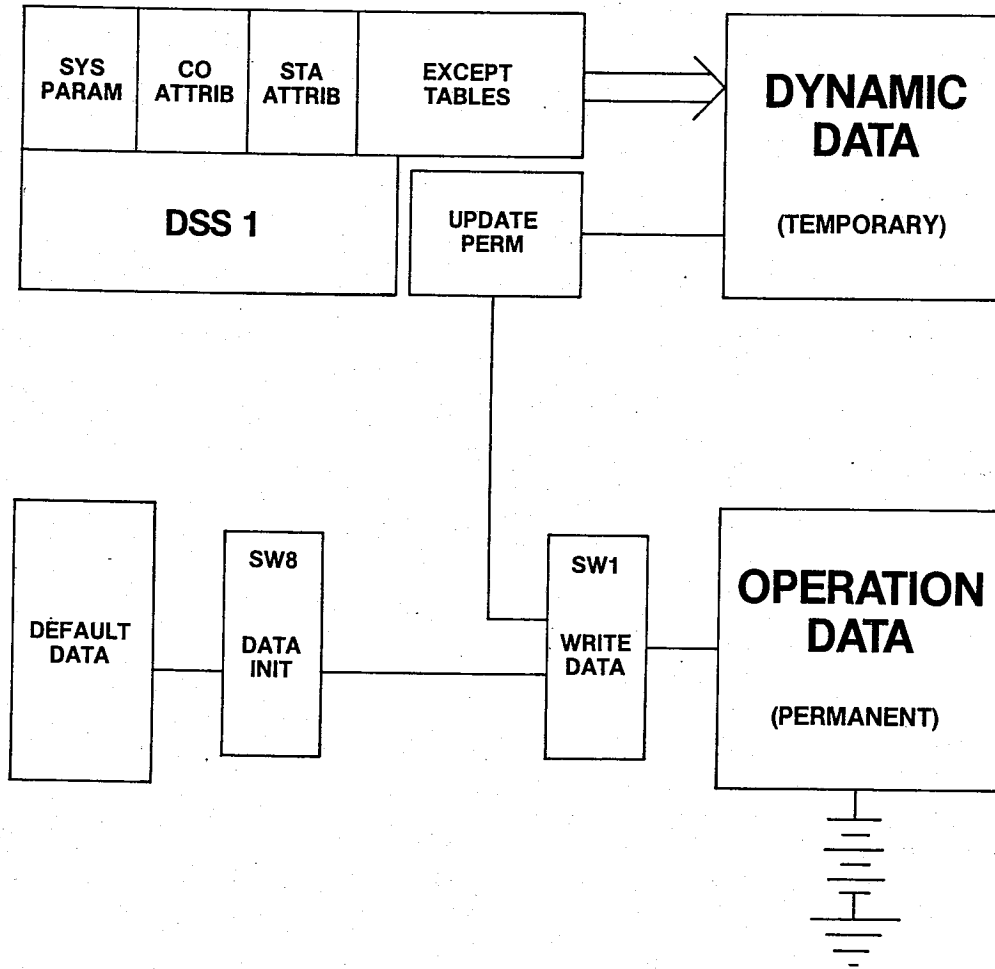

FIGURE 7.11
DATABASE FUNCTIONAL DIAGRAM

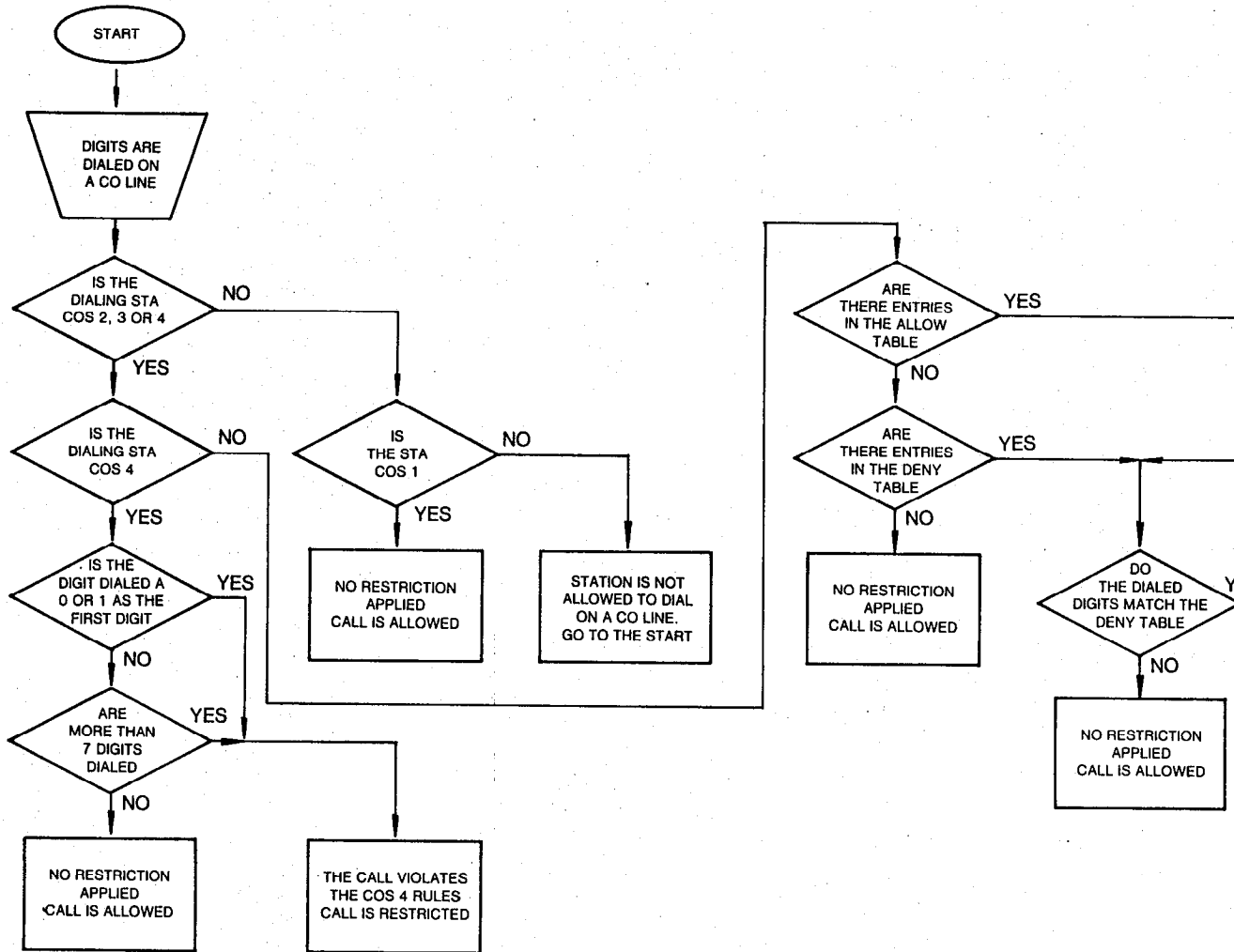

FIGURE 7.12
TOLL RESTRICTION
FLOWCHART

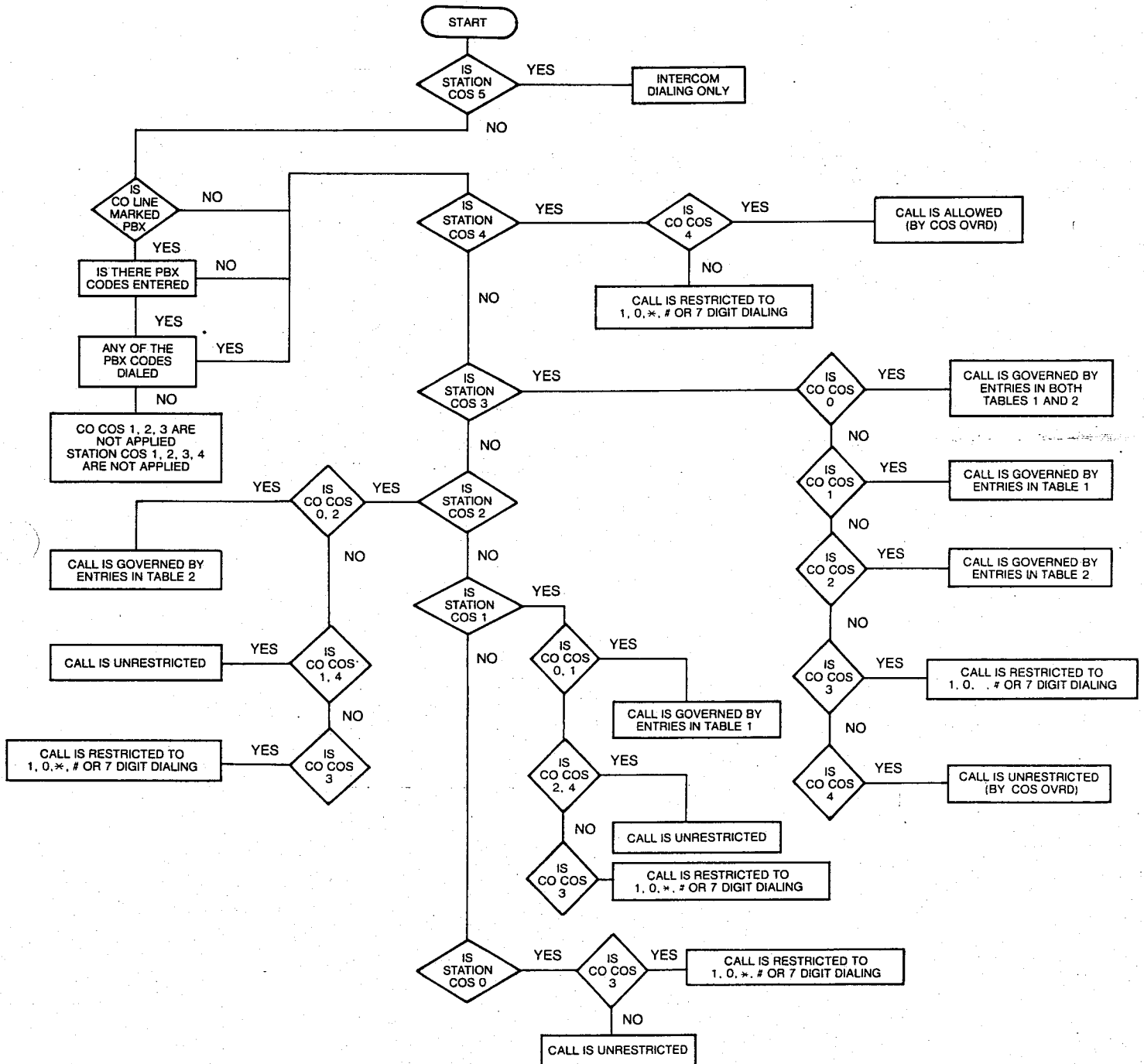

FIGURE 7.13
CLASS OF SERVICE FLOW CHART

NORTHCOM 1648 KEYSSET SYSTEM
 COPYRIGHT 1985 VERSION *
 DATE: 04/16/86 TIME: 10:39:05

SYSTEM - TEMP - **
 TIME: RECALL DISCONNECT
 EXCL XFER SYST FLSH PAGE CONF
 060 060 600 20 60 090

HUNT GROUPS
 1 : 10 11 12 13 14 15 16 17
 2 : 10 18 19 20
 3 : 10 21 22 23 24 25 26 27
 4 : ..
 5 : ..
 6 : ..

DIAG	PRE	ENR	ATO	BAUD	24
STRT	FWD			RATE	HR
12:00	20	Y	Y	S	Y
DD		LNR		LCD	
MM	LBC	SLT	SMDR	DSP	
N	D	Y	Y	Y	

PBX: 12 13 14

* DENOTES SOFTWARE VERSION.
 ** CAN BE TEMP (TEMPORRY MEMORY)
 OR PERM (PERMANENT MEMORY).

**SYSTEM PARAMETERS RECORD
 FIGURE 7.14**

SYSTEM SPEED TABLE - PERM -

ENTRY NUMBER
 10 : 16029982200
 11 : 18005551212

EMPTY ENTRIES:
 12 13 14 15 16 17 18 19 20 21 22
 23 24 25 26 27 28 29 30 31 32 33
 34 35 36 37 38 39 40 41 42 43 44
 45 50 51 52 53 54 55 56 57 58 59
 60 61 62 63 64 65 66 67 68 69 70
 71 72 73 74 75 76 77 78 79 80 81
 82 83 84 85 86 87 88 89

**SYSTEM SPEED NUMBERS RECORD
 FIGURE 7.15**

ALLOW TABLE 1 - PERM -

01	11
02	12
03	13
04	14
05	15
06	16
07	17
08	18
09	19
10	20

DENY TABLE 1 - PERM -

01	06
02	07
03	08
04	09
05	10

ALLOW TABLE 2 - PERM -

01	11
02	12
03	13
04	14
05	15
06	16
07	17
08	18
09	19
10	20

DENY TABLE 2 - PERM -

01	06
02	07
03	08
04	09
05	10

**EXCEPTION TABLES RECORD
 FIGURE 7.16**

STATION STATUS - PERM -

NUM	COS	CO	GROUP	ZONE	PRE. FWD
10	0	1	1	1	..
	SPEED	DND	STAFWD		
	Y	Y	Y		
11	0	1	1	1	..
	SPEED	DND	STAFWD		
	Y	Y	Y		
12	1	123456	1234	1234	45
	SPEED	DND	STAFWD		
	Y	Y	Y		
13	5	0	0	0	..
	SPEED	DND	STAFWD		
	N	N	N		
14	0	1	1	1	..
	SPEED	DND	STAFWD		
	Y	Y	Y		

CO LINE STATUS - TEMP -

NUM	GROUP	COS	PBX	UNA	PLS
01	1	0	N	Y	N
	DAY RING:				
	10				
	NIGHT RING:				
	10				
02	1	0	N	Y	N
	DAY RING:				
	10				
	NIGHT RING:				
	10				
03	4	3	Y	N	N
	DAY RING:				
	10 11 12 13				
	NIGHT RING:				
	24 28 29 56 27				
04	2	6	N	N	N
	DAY RING:				
	11				
	NIGHT RING:				
	57				
05	1	0	N	N	N
	DAY RING:				
	10				
	NIGHT RING:				
	10				
06	1	1	N	N	N
	DAY RING:				
	10				
	NIGHT RING:				
	10 11				

STATION RECORD
FIGURE 7.17

CO LINE RECORD
FIGURE 7.18

In order to help you understand some of the features of Feature Package II and how they function, the following case study has been devised. Based upon the instructions in these manual pages, fill out the worksheets to determine how this system should be programmed.

Answers will be found on the back pages.

WHEAT GRAIN DISTRIBUTERS OLATHE, KS

Stations: 8 LCD keysets
22 standard keysets
7 single line telephones

CO Lines: 5 "Centron" lines (PBX)
2 US Sprint lines
2 Out WATS, Band 0 (Intrastate)
3 In WATS, 1-800 numbers
1 private line

1. The system will be equipped with a mini-printer to record long distance calls only.
2. Centron lines require a 9 and an 8 as access codes. A 700 ms flash is used for call transfer. These lines should be toll restricted but allow 1-800 numbers.
3. US Sprint lines should allow out of state calls only, denying any instate calls (instate calling is to be placed on Band 0 WATS.)
4. Centron lines day ring at station 10 and night ring at stations 10 and 11.
5. In WATS day ring at station 11 and night ring at station 10 & 11.
6. Private lines will day ring at station 19, night ring at station 20 and after 10 seconds be forwarded to station 57.
7. Deny UNA on In WATS and the private line.
8. Attendant #1 and #2 should be in all page zones and be denied DND.
9. All stations have access to the centron lines. Stations 10-29, 36-39, and 57 have access to the US Sprint and Band 0 WATS lines.
10. The In WATS are to appear on stations 10, 11, 19, 20, 21, 22 & 30-35 only. The private lines is to be accessed by stations 19, 20 and 57.
11. Stations 20, 22, & 57 are to be unrestricted, station 19 & 21 are to be restricted on US Sprint lines only.
12. Warehouse phones 51-56 are to be restricted to local calls only.
13. All other stations are to follow the restrictions on the Centron and US Sprint lines.
14. Put stations 12-18 in page zone 1. Stations 19, 21, 23-29 are in page zone 2. Stations 30-38 are in page zone 3 and 39, 51-56 are in page zone 4.
15. Deny system speed dial on stations 23-29 and 51-56.
16. Deny DND on stations 30-35.
17. Put stations 30, 31, 32, 33, 34, 35 in a hunt group.

PARAMETER	FORMAT	DEFAULT	NEW VALUE
EXCLUSIVE HOLD RECALL	000-255 SEC	060 SEC	
TRANSFER RECALL	000-255 SEC	060 SEC	
SYSTEM HOLD RECALL	000-600 SEC	600 SEC	
FLASH TIMER	0.1-9.9 SEC	2.0 SEC	
PAGING TIME OUT	00-99 SEC	60 SEC	
CONFERENCE TIME OUT	000-090 MIN	090 MIN	
HUNT GROUP 1	UP TO 8 STA	NONE	
HUNG GROUP 2	UP TO 8 STA	NONE	
HUNT GROUP 3	UP TO 8 STA	NONE	
HUNT GROUP 4	UP TO 8 STA	NONE	
HUNT GROUP 5	UP TO 8 STA	NONE	
HUNT GROUP 6	UP TO 8 STA	NONE	
DIAGNOSTIC START TIME	0000-2359	2525	
PRESET FORWARD TIMER	01-40 SEC	20 SEC	
EXTERNAL NIGHT RING	Y/N	N (LED off)	
ATTENDANT OVERRIDE	Y/N	N (LED off)	
BAUD RATE SELECT	S/F (300/1200)	S (LED on)	
HOUR FORMAT	24/12	12 (LED off)	
MONTH/DAY FORMAT	DDMM/MMDD	MMDD (LED off)	
LOUD BELL CONTROL	D/N (DAY & NITE/NITE)	N (LED off)	
LAST NUMBER REDIAL-SLT	Y/N	Y (LED on)	
SMDR	Y/N (ALL. LONG DIST)	Y (LED on)	
LCD DISPLAY	Y/N	Y (LED on)	
PBX CODES	UP TO 5	NONE	

**FIGURE 7.1
CUSTOMER DEFINITION SHEET
(SYSTEM PARAMETERS OVERLAY)**

TRUNK #	GROUP (0-7)	COS (0-4)	CO/PBX LINE	DAY RING STATION #	NIGHT RING STATION #	UNA (Y/N)	PULSE (Y/N)	REMARKS
CO 01								
CO 02								
CO 03								
CO 04								
CO 05								
CO 06								
CO 07								
CO 08								
CO 09								
CO 10								
CO 11								
CO 12								
CO 13								
CO 14								
CO 15								
CO 16								
01-16	1	0	CO (LED OFF)	10	10	Y	N	DEFAULT

NOTES:

1. A CO/PX LINE MAY ONLY BE IN ONE CO LINE GROUP.

FIGURE 7.2
 CUSTOMER DEFINITION SHEET
 (CO LINE OVERLAY)

STATION #	COS 0-5	PAGE ZONE 0, 1, 2, 3, 4	LINE GROUP 0, 1, 2, 3, 4, 5, 6, 7	SYS SPD Y/N	DND Y/N	STA FWD Y/N	*PRE FWD STA #	REMARKS
10								
11								
12								
13								
14								
15								
16								
17								
18								
19								
20								
21								
22								
23								
24								
25								
26								
27								
28								
29								
30								
31								
32								
33								
34								
35								
36								
37								
38								
39								
40								
41								
42								
43								
44								
45								
46								
47								
48								
49								
50								
51								
52								
53								
54								
55								
56								
57								
10-57	0	1	1	Y	Y	Y	—	DEFAULT

*PRE FWD is for incoming CO ringing only.

**FIGURE 7.3
CUSTOMER DEFINITION SHEET
(STATION OVERLAY)**

TABLE #	BIN #	NUMBER TO ALLOW/DENY (8 DIGITS MAX)	BIN #	NUMBER TO ALLOW/DENY (8 DIGITS MAX)
		PAGE 1		PAGE 2
ALLOW 1	1		11	
ALLOW 1	2		12	
ALLOW 1	3		13	
ALLOW 1	4		14	
ALLOW 1	5		15	
ALLOW 1	6		16	
ALLOW 1	7		17	
ALLOW 1	8		18	
ALLOW 1	9		19	
ALLOW 1	10		20	
DENY 1	1		6	
DENY 1	2		7	
DENY 1	3		8	
DENY 1	4		9	
DENY 1	5		10	
ALLOW 2	1		11	
ALLOW 2	2		12	
ALLOW 2	3		13	
ALLOW 2	4		14	
ALLOW 2	5		15	
ALLOW 2	6		16	
ALLOW 2	7		17	
ALLOW 2	8		18	
ALLOW 2	9		19	
ALLOW 2	10		20	
DENY 2	1		6	
DENY 2	2		7	
DENY 2	3		8	
DENY 2	4		9	
DENY 2	5		10	

FIGURE 7.5
 CUSTOMER DEFINITION SHEET
 (EXCEPTION TABLE OVERLAY)

PARAMETER	FORMAT	DEFAULT	NEW VALUE
EXCLUSIVE HOLD RECALL	000-255 SEC	060 SEC	
TRANSFER RECALL	000-255 SEC	060 SEC	
SYSTEM HOLD RECALL	000-600 SEC	600 SEC	
FLASH TIMER	0.1-9.9 SEC	2.0 SEC	0.7
PAGING TIME OUT	00-99 SEC	60 SEC	
CONFERENCE TIME OUT	000-090 MIN	090 MIN	
HUNT GROUP 1	UP TO 8 STA	NONE	30, 31, 32, 33, 34, 35
HUNT GROUP 2	UP TO 8 STA	NONE	
HUNT GROUP 3	UP TO 8 STA	NONE	
HUNT GROUP 4	UP TO 8 STA	NONE	
HUNT GROUP 5	UP TO 8 STA	NONE	
HUNT GROUP 6	UP TO 8 STA	NONE	
DIAGNOSTIC START TIME	0000-2359	2525	
PRESET FORWARD TIMER	01-40 SEC	20 SEC	10
EXTERNAL NIGHT RING	Y/N	N (LED off)	
ATTENDANT OVERRIDE	Y/N	N (LED off)	
BAUD RATE SELECT	S/F (300/1200)	S (LED on)	F1200 (LED off)
HOUR FORMAT	24/12	12 (LED off)	
MONTH/DAY FORMAT	DDMM/MMDD	MMDD (LED off)	
LOUD BELL CONTROL	D/N (DAY & NITE/NITE)	N (LED off)	
LAST NUMBER REDIAL-SLT	Y/N	Y (LED on)	
SMDR	Y/N (ALL. LONG DIST)	Y (LED on)	N (LED only)
AUTOMATIC SELECT	Y/N	Y (LED on)	
LCD DISPLAY	Y/N	Y (LED on)	
PBX CODES	UP TO 5	NONE	9S9S

**CUSTOMER DEFINITION SHEET
(SYSTEM PARAMETERS OVERLAY)
FIGURE 7.1**

TRUNK #	GROUP (0-7)	COS (0-4)	CO/PBX LINE	DAY RING STATION #	NIGHT RING STATION #	UNA (Y/N)	PULSE (Y/N)	REMARKS
CO 01	1	1	PBX	10	10, 11			Centron
CO 02	1	1	PBX	10	10, 11			Centron
CO 03	1	1	PBX	10	10, 11			Centron
CO 04	1	1	PBX	10	10, 11			Centron
CO 05	1	1	PBX	10	10, 11			Centron
CO 06	2	2						US Sprint
CO 07	2	2						US Sprint
CO 08	3							Out Wats Band 0
CO 09	3							Out Wats Band 0
CO 10	4			11	10, 11	N		In Wats 1800
CO 11	4			11	10, 11	N		In Wats 1800
CO 12	4			11	10, 11	N		In Wats 1800
CO 13	5			19	20	N		Private Line
CO 14	0							
CO 15	0							
CO 16	0							
01-16	1	0	CO (LED OFF)	10		Y	N	DEFAULT

NOTES:

1. A CO/PBX LINE MAY ONLY BE IN ONE CO LINE GROUP.

**CUSTOMER DEFINITION SHEET
(CO LINE OVERLAY)
FIGURE 7.2**

STATION #	COS 0-5	PAGE ZONE 0-4	LINE GROUP 0-7	SYS SPD Y/N	DND Y/N	STA FWD Y/N	PRE FWD STA #	REMARKS
10	3	1 2 3 4	1 2 3 4		N	N		Attendant #1
11	3	1 2 3 4	1 2 3 4		N			Attendant #2
12	3	1	1 2 3					
13	3	1	1 2 3					
14	3	1	1 2 3					
15	3	1	1 2 3					
16	3	1	1 2 3					
17	3	1	1 2 3					
18	3	1	1 2 3					
19	2	2	1 2 3 4 5					Secretary
20	0	0	1 2 3 4 5				57	Executive
21	2	2	1 2 3 4					Secretary
22	0	0	1 2 3 4					Executive
23	3	2	1 2 3	N				Sales
24	3	2	1 2 3	N				Sales
25	3	2	1 2 3	N				Sales
26	3	2	1 2 3	N				Sales
27	3	2	1 2 3	N				Sales
28	3	2	1 2 3	N				Sales
29	3	2	1 2 3	N				Sales
30	3	3	1 4		N			Customer
31	3	3	1 4		N			Service
32	3	3	1 4		N			Service
33	3	3	1 4		N			Service
34	3	3	1 4		N			Service
35	3	3	1 4		N			Service
36	3	3	1 2 3					
37	3	3	1 2 3					
38	3	3	1 2 3					
39	3	4	1 2 3					Warehouse Sup.
40								
41								
42								
43								
44								
45								
46								
47								
48								
49								
50								
51	4	4	1	N				Warehouse
52	4	4	1	N				Warehouse
53	4	4	1	N				Warehouse
54	4	4	1	N				Warehouse
55	4	4	1	N				Warehouse
56	4	4	1	N				Warehouse
57	0	0	1 2 3 4 5					OPS-Executive
10-57	0	1	1	Y	Y	Y	-	DEFAULT

* PRE FWD is for incoming co ringing only.

**CUSTOMER DEFINITION SHEET
(STATION OVERLAY)
FIGURE 7.3**

TABLE #	BIN #	NUMBER TO ALLOW/DENY (8 DIGITS MAX)	BIN #	NUMBER TO ALLOW/DENY (8 DIGITS MAX)
		PAGE 1		PAGE 2
ALLOW 1	1	1800	11	
ALLOW 1	2		12	
ALLOW 1	3		13	
ALLOW 1	4		14	
ALLOW 1	5		15	
ALLOW 1	6		16	
ALLOW 1	7		17	
ALLOW 1	8		18	
ALLOW 1	9		19	
ALLOW 1	10		20	
DENY 1	1	0	6	
DENY 1	2	1	7	
DENY 1	3		8	
DENY 1	4		9	
DENY 1	5		10	
ALLOW 2	1		11	
ALLOW 2	2		12	
ALLOW 2	3		13	
ALLOW 2	4		14	
ALLOW 2	5		15	
ALLOW 2	6		16	
ALLOW 2	7		17	
ALLOW 2	8		18	
ALLOW 2	9		19	
ALLOW 2	10		20	
DENY 2	1	1316	6	1*6
DENY 2	2	1*2	7	1*7
DENY 2	3	1*3	8	1*8
DENY 2	4	1*4	9	1*9
DENY 2	5	1*5	10	

**CUSTOMER DEFINITION SHEET
(EXCEPTION TABLE OVERLAY)
FIGURE 7.5**