

STATION DOOR PHONE V-5324004

INTRODUCTION

The Station Door Phone is specifically designed to communicate with a telephone system that provides Primeline, Off-hook ring-down, Hotline and Elevator Call capabilities.

The Station Door Phone connects to a standard telephone system analog station port to allow the caller at the door speaker to have a two-way conversation with someone inside the building. The weather resistant enclosure is ideal for indoor or outdoor environments.

SPECIFICATIONS

FEATURES

- Push Button - to initiate signalling
- LED - lights up to indicate activation
- Two-way handsfree voice communication
- Volume Control - adjusts speaker volume
- No external power required
- Stainless steel faceplate with tamper resistant hardware
- Weather resistant enclosure
- VOX circuit - to turn unit off with lack of voice activity
- Turns off if button is depressed a second time
- Alert tone emits from speaker when accessed

Dimensions/Weight

- 4.63"W x 4.63"H x 1.75"D
(11.76cm x 11.76cm x 4.45cm)
- 1.52 lbs. (0.68 kg) with gang box
- 0.72 lbs. (0.32 kg) without gang box

OPERATION

Off-Hook Ring-down, Hotline, Primeline

The Station Door Phone operates much like a telephone without a dial-pad. It connects to an analog station port on a telephone system. When the Station Door Phone push button is pressed,



this unit provides an off-hook condition to the telephone system analog station port, the faceplate LED lights, and an alert tone beeps at the speaker.

Some telephone systems provide a programmable auto-dial/ring-down feature. When used with these telephone systems, the phone system will automatically dial a telephone number (preprogrammed into the phone system software) when the Station Door Phone push button is pressed. The person answering the ringing phone inside is automatically connected to the caller at the Station Door Phone.

To call the Station Door Phone from a telephone, dial the extension number, just as you would dial a telephone extension.

NOTE: See Figure 5 for normal default Dip Switch settings.

Auxiliary Alert

The Station Door Phone can be used to activate an Auxiliary Alert device (such as a door bell or chime) instead of ringing a telephone.

VOX Operation

The Station Door Phone is equipped with a VOX (voice activated switch) circuit. This feature is provided to automatically drop communications to the

door speaker when there is no audio detected, for more than 24 seconds, from the telephone extension within the building. Visitors talking into the door speaker will not affect the VOX circuit.

INSTALLATION

There are two surface mount methods to secure the Station Door Phone to a wall. The first method utilizes mounting brackets. The gang box mounting brackets (included) can be screwed to the back plate so they protrude out the sides of the box. Position the screws through the bracket holes and secure the box to the wall.

Another method to attach the gang box to the surface of a wall is to drill mounting holes (4) directly into the back of the box. Position the screws through the inside of the box and secure to the wall.

NOTE: All conduit and closure plug connections should be adequately sealed (i.e., pipe joint compound) for wet location installations.

Do not allow conduit to protrude into rear opening of outlet box to avoid interference with Station Door Phone. Wire length should be kept to 6 inches to avoid interferences during installation. For maximum protection from ESD or lightning, connect the outlet box to earth ground via the conduit.

CONNECTIONS

The Station Door Phone back panel has two sets of terminals; one set is labeled ALERT, and the other labeled TIP/RING (see Figure 1). The TIP/RING terminals that connect to your telephone system must use twisted pair phone wire. See Figure 2 for wiring diagram. Follow steps below:

NOTE: Check National Electrical Code and applicable local codes and ordinances for exact wiring requirements for your area.

1. Loosen each of the terminal block screws and insert exposed wire ends into appropriate terminal block locations. Tighten screws and ensure wire connections are correct before continuing.

2. Place the dip switch in the position shown in Figure 5 (factory default setting). Program your telephone system for the phone number(s) to be called when the Station Door Phone button is activated.

Dipswitch Features

Guard Mode - Alerts the guard with the second DPDT (Double Pole, Double Throw) contacts and disables off-hook control.

Elevator Mode - Depressing button activates the unit and can not be turned off (on-hook) and disables VOX timeout.

Push On-Push Off Mode - Depress button to activate, press again to cancel. 24 second VOX timeout. Factory default position.

Line Flash Ring Mode - Depress button to activate. Press again to flash (800ms) to signify "telephone" host system to re-ring.

Push On Only Mode - Depressing button activates unit and can not be turned off, unit returns on-hook status after 24 second timeout period.

Momentary Page Mode - Push to activate.

NOTE: Total length of wire from the door phone unit to the telephone system is not to exceed 1500 feet.

3. Connect the Station Door Phone wires to the designated station port on the telephone system.
4. Test the system by having an assistant call the designated extension number of the Station Door Phone. Adjust the speaker volume (see Figure 3) to an appropriate level.
5. Place poly-fil pad in designated position for good sound quality (see Figure 3).
6. Secure Station Door Phone and faceplate to double-gang outlet box with four mounting screws (included).

INSTALLATION INSTRUCTIONS CUSTOMER PROVIDED OR EXISTING DOOR ALERT (SIGNALLING UNIT)

These instructions apply to the use of a customer provided auxiliary alert or an existing door alert (signaling) unit.

1. Connect Station Door Phone to existing door alert push button so that existing button is in parallel with Station Door Phone Terminals 1 and 2 (see Figure 2).

NOTE: While Station Door Phone button or existing door bell button is depressed some types of alerting devices will continue to sound or operate.

If desired, the existing door bell button can be removed thus allowing the Station Door Phone button to replace the function of the existing door bell button. Connect wires from existing door bell button to Terminals 1 and 2 on the Station Door Phone (see Figure 4).

NOTE: When using Auxiliary Alert option, all four wires must be connected.

TECHNICAL ASSISTANCE

When calling, have a VOM and a telephone test set available and call from the job site. Call (800) 782-5266 for PagePac Technical Support, or visit our websites at <http://www.pagepac.com> and www.valcom.com.

Should repairs be necessary, attach a tag to the unit clearly stating company name, address, phone number, contact person, and the nature of the problem. Send the unit to:

Valcom, Inc.
PagePac® Repair Dept.
5614 Hollins Road
Roanoke, VA 24019-5056

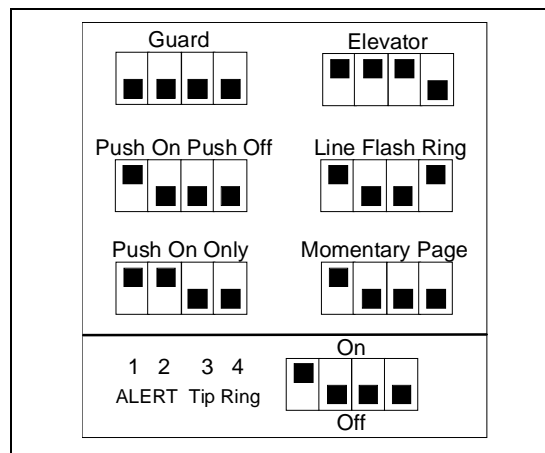

Figure 1. Station Door Phone Terminal Block and Dip Switches

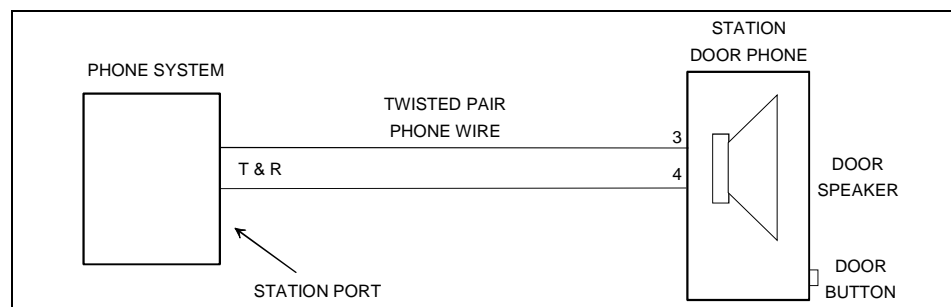

Figure 2. Station Door Phone Wiring Diagram

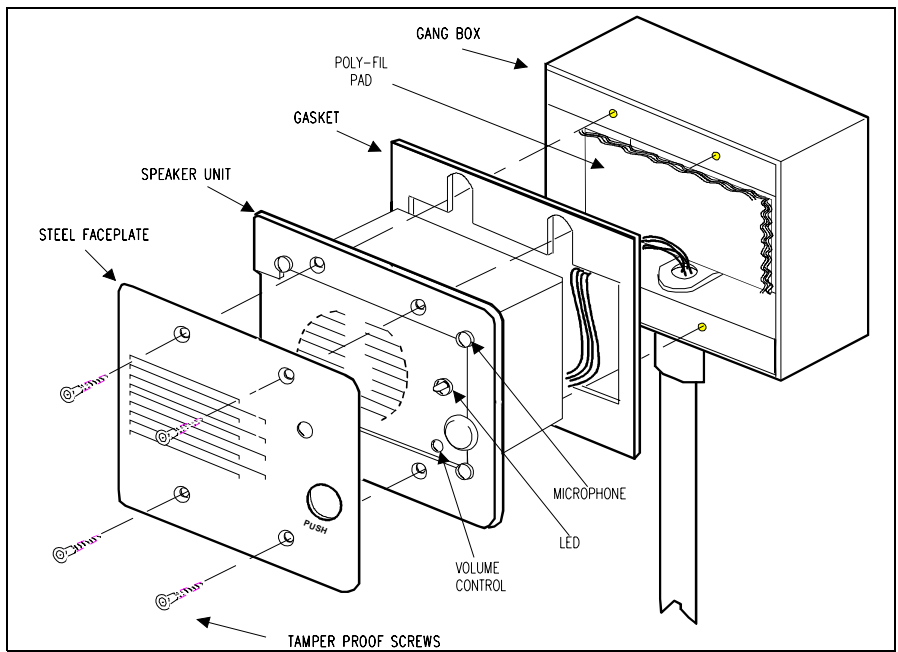

Figure 3. Attach Station Door Phone and Faceplate

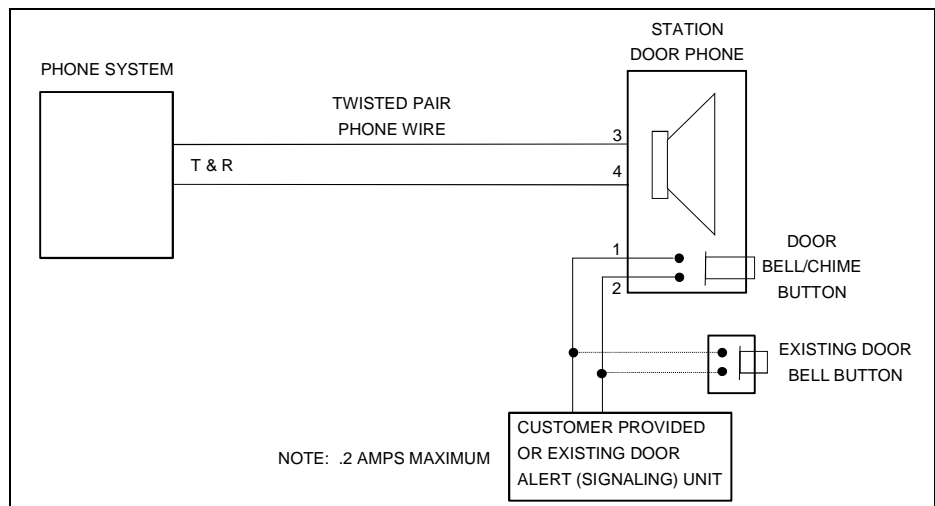

Figure 4. Wiring Diagram for Customer Provided or Existing Alerters

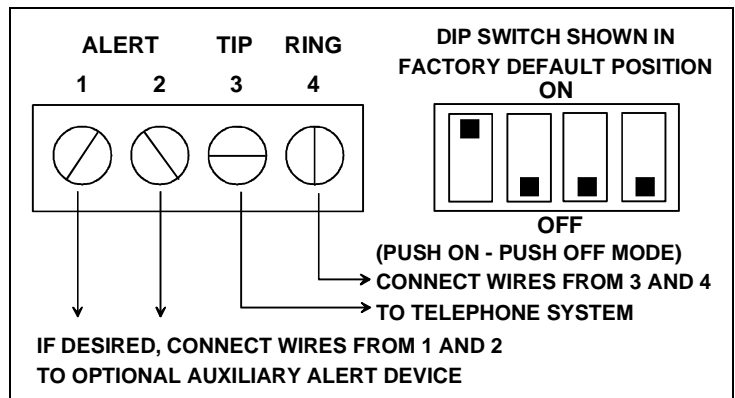

Figure 5. Station Door Phone Back Panel Connections