

# Panasonic

Automatic Telephone  
Answering System

## KX-T1450

MODEL NO. **KX-T1451**

**EASA-PHONE**

### OPERATING INSTRUCTIONS

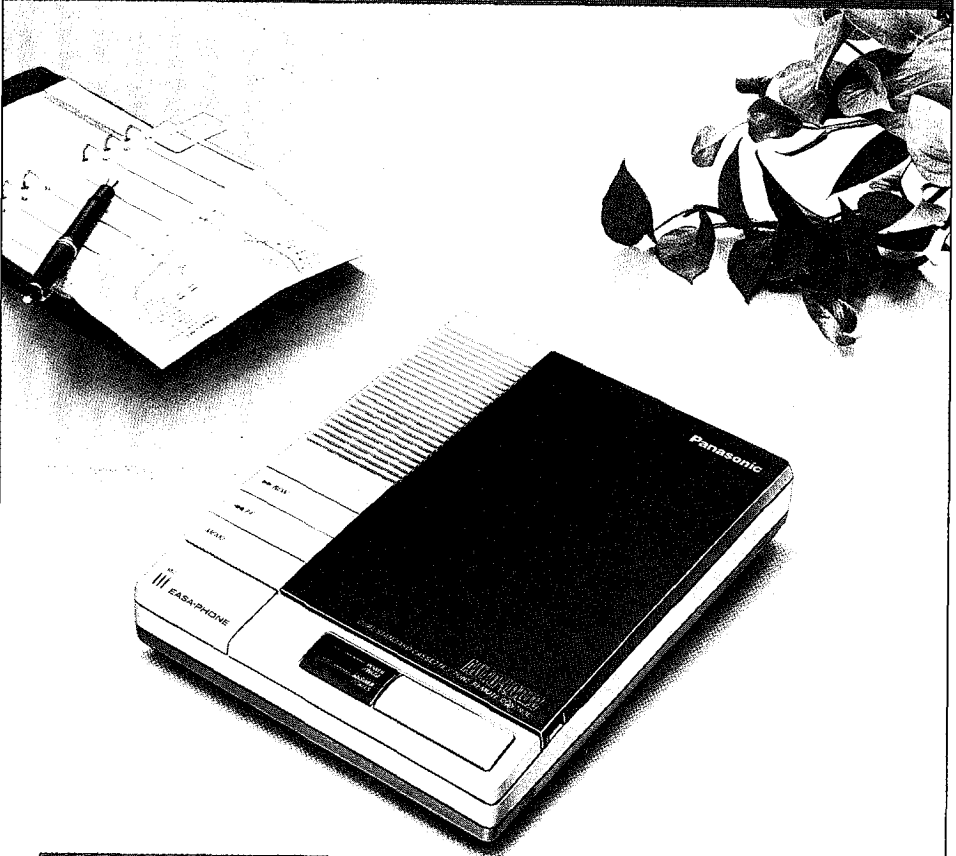

**Please read before use.**

La referencia rápida en español puede ser encontrada en las páginas 21~23.  
(Spanish Quick Reference can be found on pages 21~23.)

The unit in this picture is the  
KX-T1450.

## AUTO-LOGIC™

# Table of Contents

---

Locations of the Controls .....	2
Introduction .....	3
Preparation	
CONNECTION .....	4
INITIAL SETTINGS .....	5
TOLL SAVER .....	5
CASSETTE TAPE INSTALLATION .....	6
How to Record an Outgoing Message (OGM)	
RECORDING THE OGM .....	7
CHECKING YOUR OGM .....	8
SAMPLE OGMS .....	8
Setting Prior to Leaving	
RECORDING THE CALLERS' MESSAGES .....	9
PREPARING THE ICM TAPE .....	9
Listening to the Recorded Messages	
LISTENING TO THE MESSAGES .....	10
RE-PLAYING BACK ALL THE MESSAGES .....	10
Other Features	
RECORDING A PERSONAL MESSAGE (MESSAGE MEMO) .....	11
SAVING THE RECORDED MESSAGES .....	12
ERASING THE RECORDED MESSAGES .....	13
MONITORING THE INCOMING CALLS .....	13
How to Operate from a Remote Phone	
SETTING THE REMOTE CODE .....	14
PLAYING BACK MESSAGES .....	15
PLAYING BACK NEWLY-RECORDED MESSAGES (MEMORY PLAYBACK) .....	15
REWINDING/FAST FORWARDING TAPE WHILE HEARING THE MESSAGES .....	16
RECORDING A MARKER MESSAGE .....	16
RESETTING THE ICM TAPE FOR FUTURE MESSAGES .....	17
MONITORING ROOM SOUND .....	17
CHANGING THE OUTGOING MESSAGE .....	18
SKIPPING THE OGM FOR ICM RECORDING .....	18
SETTING/CANCELLING THE ANSWER MODE .....	19
Troubleshooting Guide .....	20
Referencia Rápida (Spanish Quick Reference) .....	21
Maintenance .....	24
Cassette Tape .....	24
Others .....	25
Accessory Order Information .....	25
Important Information .....	26

# Location of the Controls

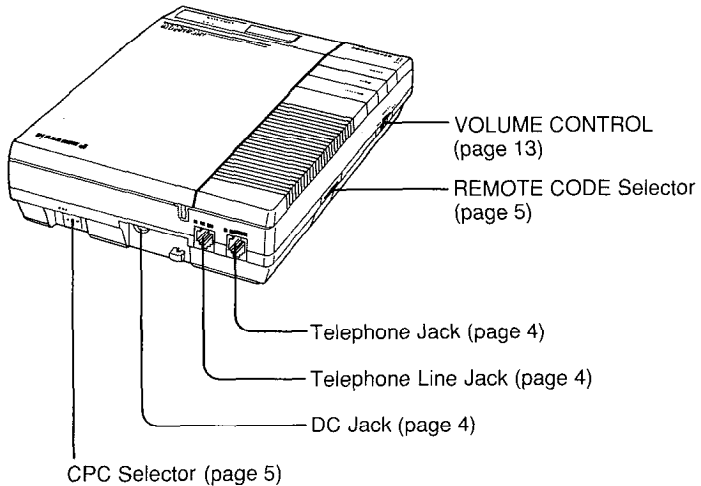
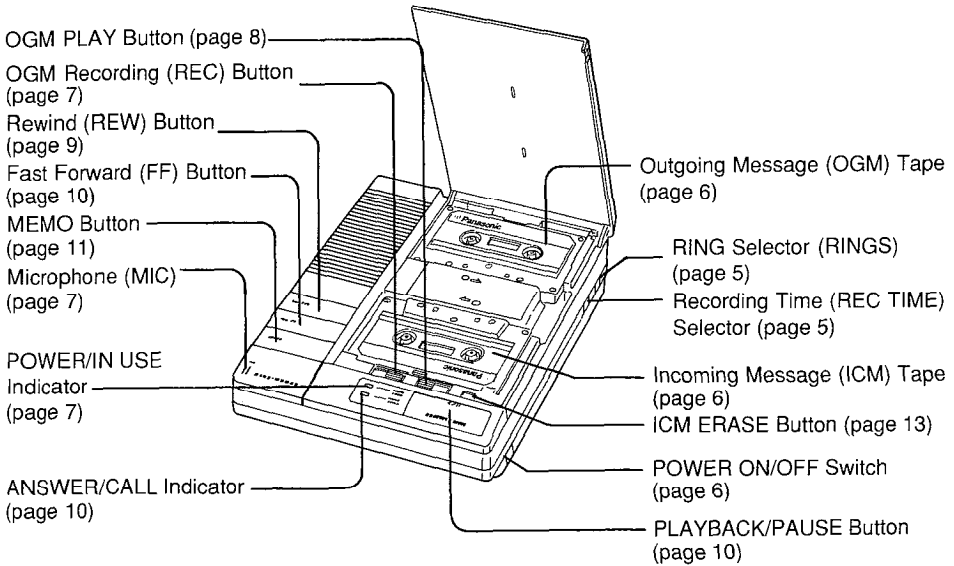

**Keep this overleaf unfolded while you are reading this Operating Instructions. This makes it easier to locate the controls and switches mentioned in the instructions.**

# Introduction

---

*Thank you for purchasing the Panasonic Telephone Answering System.*

***You can use this Model KX-T1450/KX-T1451 to:***

- Answer calls and record messages when you cannot answer the telephone or do not want to be disturbed
- Monitor (screen) calls
- Record your personal messages

***By using the advanced remote-control features of your KX-T1450/KX-T1451, you can also***

- Call in from another touch tone telephone to listen to your messages
- Record a new Outgoing Message even when you are away from your unit
- Leave a message while you are away from your unit

**We recommend that you read these Operating Instructions all the way through before you set up and use your Answering System.**

## **Accessories**

- AC Adaptor . . . . . one
- Telephone Cord . . . . . one
- Outgoing Message Tape  
(Standard Cassette) . . . . . one
- Incoming Message Tape  
(Standard Cassette) . . . . . one

# Preparation

## CONNECTION

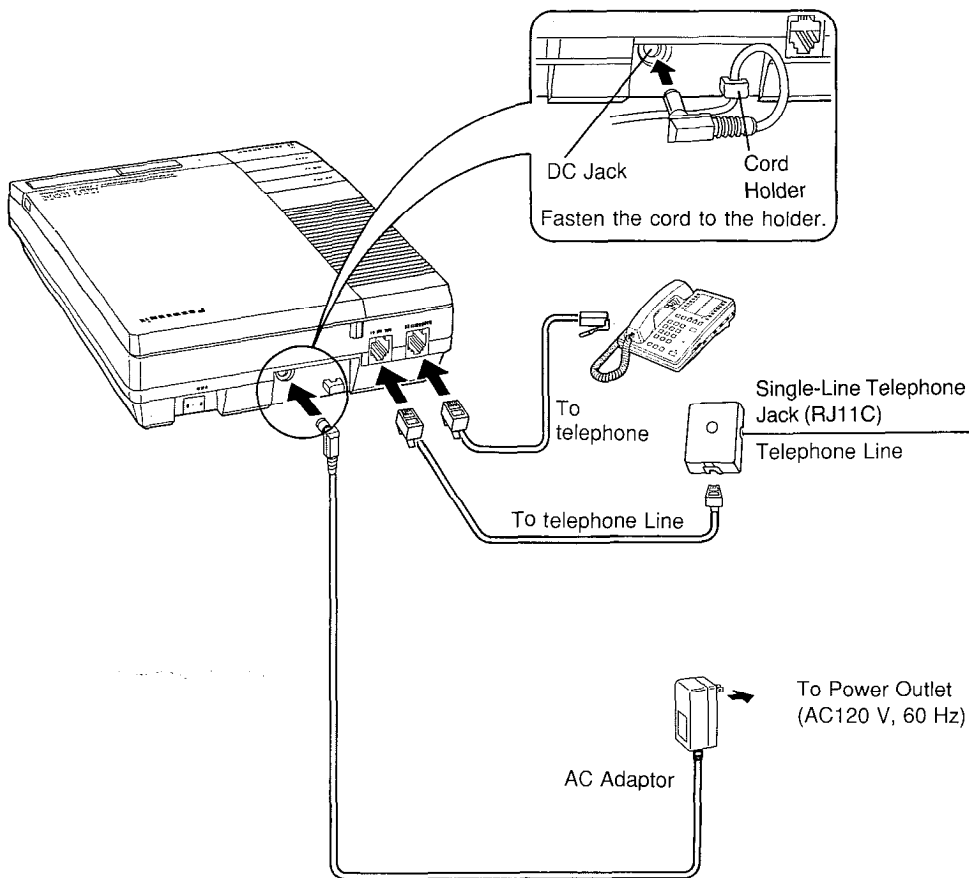

***Do not connect the AC adaptor to the AC outlet before inserting the OGM and ICM tapes. (See page 6.)***

- **USE ONLY PANASONIC AC ADAPTOR KX-A11.**
- The unit must not be connected to a coin operated line. If you are on a party line, check with your local telephone company.
- While operating the unit, the cabinet of the AC Adaptor may feel warm, this is a normal condition.

---

## INITIAL SETTINGS

---

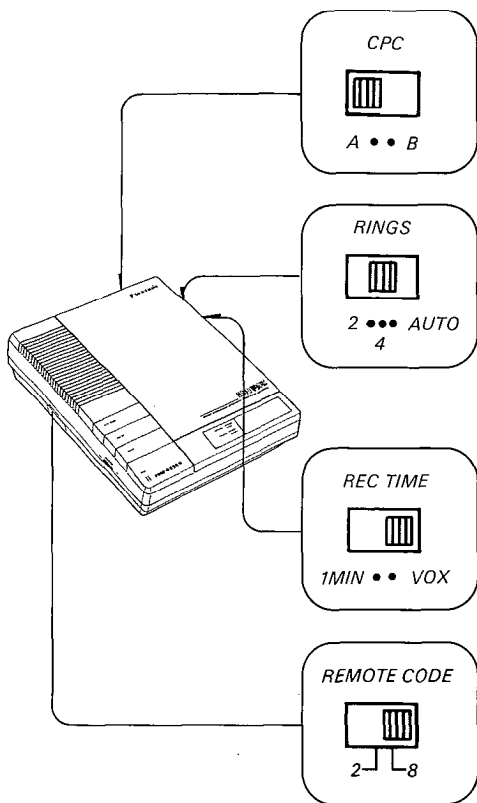

### Calling Party Control (CPC) Setting

Set to "A". (no call waiting service line.)

If you have call waiting service or some Incoming Messages are interrupted, set to "B".

### Number of Rings

- 2..... The unit will answer a call on the second ring.
- 4..... The unit will answer a call on the fourth ring.
- AUTO..... See "TOLL SAVER" on this page.

### Recording Time Selector

- VOX..... The unit will record for as long as the caller speaks.
- 1 minute.. The unit will record up to 1 minute. (1 MIN)

### Remote Code

The remote code number is made up of 2 digits.

The first digit is factory preset, and the second digit is selectable. (2 or 8)

Also, refer to page 14 for your remote code setting.

---

## TOLL SAVER

---

The TOLL SAVER feature lets you avoid a toll charge when you call your unit and no messages have been recorded.

1 Set the number of rings to **AUTO**.

●If the unit does not pick up on the third ring, hang up immediately. This means that you have no messages and you have saved a toll charge.

■ The unit picks up **on the second ring**:

It means that at least one message has been recorded.

■ After you have played back all the messages from a remote phone, **the unit will pick up the next call on the fourth ring**. If the unit picks up on the second ring, it means that at least one new message has been recorded.

## CASSETTE TAPE INSTALLATION

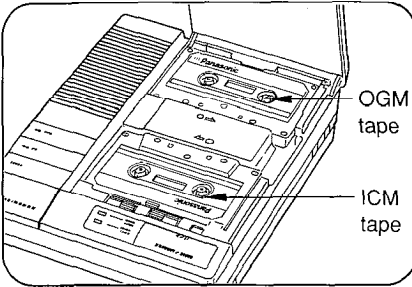

1 Open the panel, and insert the Outgoing Message (OGM) and Incoming Message (ICM) tapes as shown.

- Two cassette tapes are included. Use C15 for OGM and C60 for ICM.
- Do not use endless loop cassette tape.

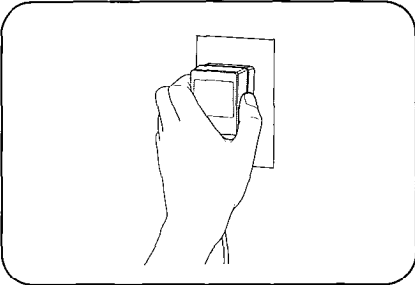

2 Connect the AC adaptor to the AC outlet.

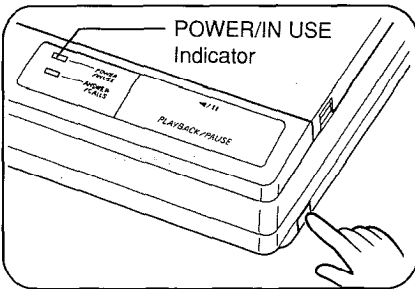

3 Set the POWER ON/OFF switch to ON.

- The unit will start to reset the OGM tape.

### NOTES:

- **3 minutes** after connecting the AC adaptor, the unit will be powered ON automatically and reset the OGM tape even when the **POWER ON/OFF** switch is not set to ON.
- **After you have changed the OGM tape:** Push **OGM PLAY** and **REW** simultaneously to reset the OGM tape.

# How to Record an Outgoing Message (OGM)

Before operating your unit, you must record an Outgoing Message (OGM). The OGM will inform the calling party of your absence and your message.

## RECORDING THE OGM

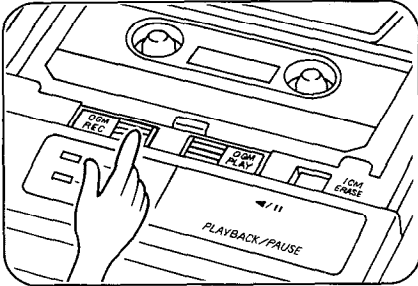

- 1 Push **OGM REC** until a long beep is heard, then release it.

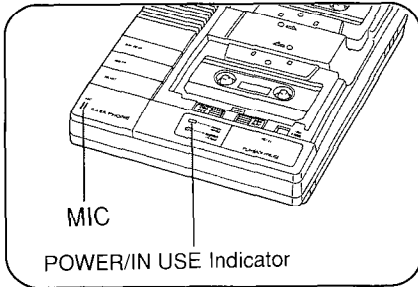

- 2 After the long beep, speak clearly and loudly into the microphone (MIC), approximately 8 inches away.

- The IN USE indicator will flash.
- The recording time is up to the tape length that you use.

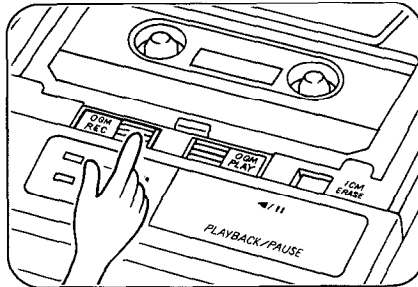

- 3 When recording is finished, push **OGM REC** again.

- The unit will rewind the tape to the beginning, and be ready for Incoming Calls.

### NOTE:

*If you pause for over 2 seconds while recording, you will hear a series of warning tones (6 beeps) and the unit will start rewinding the tape. If this happens, start with step 1 again after the unit stops rewinding.*



---

## CHECKING YOUR OGM

---

You can check your OGM at any time.

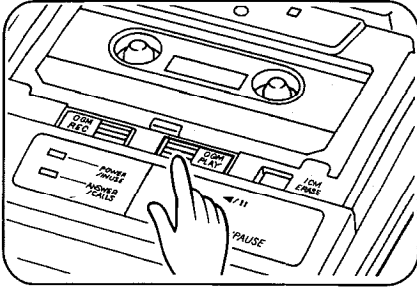

### 1 Push **OGM PLAY**.

- The unit will play back the OGM, then rewind the tape to the beginning.
- Use the **VOLUME** control on the left side of your unit to regulate the volume during playback if necessary.
- To stop the operation while playing back the OGM, push the **OGM PLAY** button.

### NOTES:

- The unit will automatically change to the Answer mode 7 seconds after completing the OGM recording or checking.
- Answer mode:**  
When a call is received, the unit will automatically answer and record Incoming Messages on the ICM tape.

---

## SAMPLE OGMS

---

When you have set **the Recording Time to "VOX"**

(For setting the recording time, see page 5.):

"Hello, this is the Smith residence. We cannot come to the phone right now. If you would like us to call you back, please leave a message, including your name and telephone number after the beep. Thank you for calling."

"This is the Panasonic (your name or business) Sales Company. We are glad that you called but our office is closed until 9 o'clock in the morning. If you leave a message, including your name and telephone number after the beep, we will return your call as soon as we can. Thank you."

When you have set **the Recording Time to "1 MIN"**:

"Hello, this is (your name, business and/or telephone No.).

I am sorry I am not here to speak to you at the moment. Please leave a message after the beep. **You have up to 1 minute for recording.** Thank you."

# Setting Prior to Leaving

## RECORDING THE CALLERS' MESSAGES

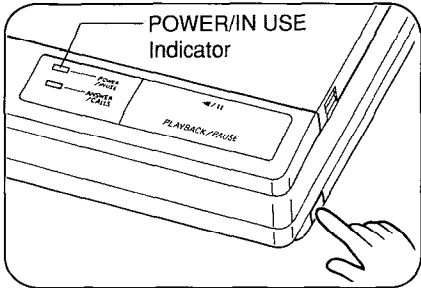

- 1 Push **POWER ON/OFF** to **ON**.
  - The POWER indicator will light.

### NOTES:

- The unit will automatically switch itself to the Answer mode 7 seconds after you set the POWER ON/OFF switch or you complete some other operations. When the telephone rings, the unit will play back your OGM, then it will record the callers' messages on the tape.
- If you do not want to set the unit to the Answer mode, set the POWER ON/OFF switch to OFF.

## PREPARING THE ICM TAPE

After reviewing the Incoming Messages, the unit will automatically reset itself to the Answer mode.

- To record future messages after the last message; leave the unit as is. All calls will be saved.
- To record the future messages from the beginning of the tape;

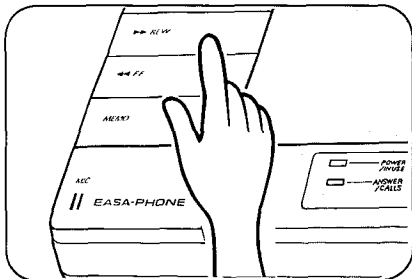

- 1 Push **REW**.

# Listening to the Recorded Messages

---

- When Incoming Messages have been recorded, the ANSWER/CALL indicator will flash. (Three flashes followed by a pause means that 3 messages were recorded.)
- In case of a power interruption, the ANSWER/CALL indicator will flash slowly after the power is restored.

---

## LISTENING TO THE MESSAGES

---

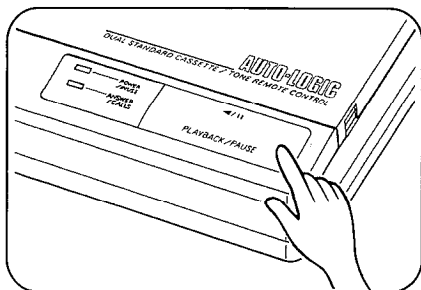

### 1 Push **PLAYBACK/PAUSE**.

- The playback volume is adjustable using the **VOLUME** control (left side on your unit).

### **AUTO-LOGIC (One-Touch Operation):**

At the touch of the **PLAYBACK/PAUSE** button, the unit will automatically rewind and play back all the recorded messages. At the end of the last message, you will hear 3 beeps. After 7 seconds, the unit will reset itself to the Answer mode. All calls will be automatically saved.

- **Future Incoming Messages will be recorded after the last message.**
- **To record the future messages from the beginning of the tape, push the **REW** button.**
- To stop the tape temporarily during playback, push the **PLAYBACK/PAUSE** button once. The IN USE indicator will flash. The tape will pause until you restart by pushing it again.
- To rewind the tape, push the **REW** button.
- To fast forward the tape, push the **FF** button.

---

## RE-PLAYING BACK ALL THE MESSAGES

---

- 1 Wait until the ANSWER/CALL indicator is lit after playing back all the messages.
- 2 Push **PLAYBACK/PAUSE**.

- The unit will play back all the recorded messages again.
- If you push the **PLAYBACK/PAUSE** button before the ANSEWR/CALL indicator is lit, push the **REW** button to rewind the tape. Within 7 seconds after rewinding, push the **PLAYBACK/PAUSE** button to re-play back all the messages.

# Other Features

## **RECORDING A PERSONAL MESSAGE (MESSAGE MEMO)**

You may record a personal message any time at home on the ICM tape. It will be heard by anyone retrieving messages from the unit.

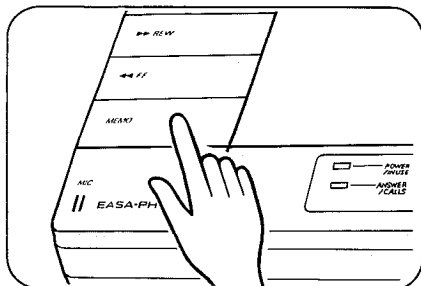

1 Push **MEMO** until a beep is heard.

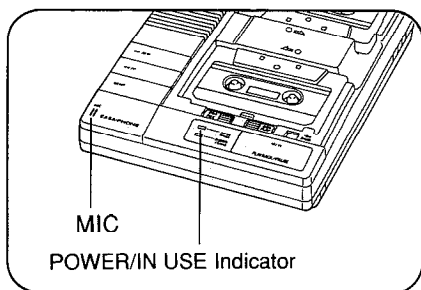

2 **Speak** into the MIC.

- The IN USE indicator will flash.

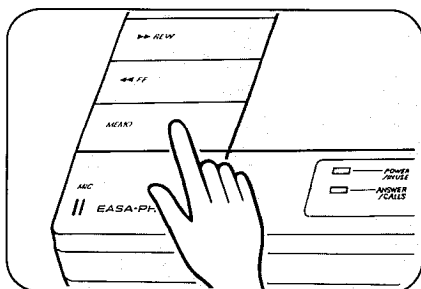

3 When finished recording, push **MEMO** again.

- The IN USE indicator will stop flashing.
- The ANSWER/CALL indicator will flash to show that your message was recorded, and the unit will be ready to answer the phone call.
- New messages will be automatically recorded after your memo.

## SAVING THE RECORDED MESSAGES

You can save the desired messages.

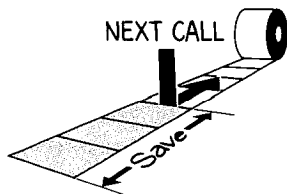

1 Play back the tape through the message you want to save.

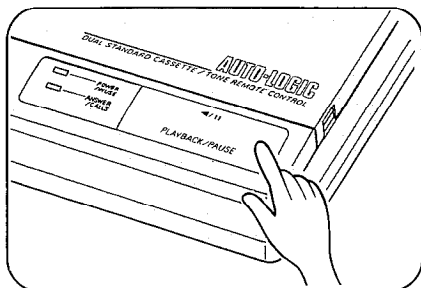

2 Push **PLAYBACK/PAUSE** to pause.

- The IN USE indicator will flash.

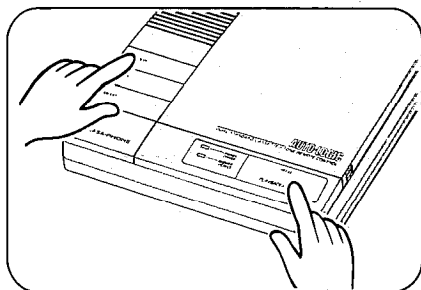

3 Push **PLAYBACK/PAUSE** and **REW** simultaneously.

- The IN USE indicator will stop flashing.
- The ANSWER/CALL indicator will light.



# How to Operate from a Remote Phone

On the following pages, we explain how to:

- SETTING THE REMOTE CODE
- PLAYING BACK MESSAGES
- PLAYING BACK NEWLY-RECORDED MESSAGES (MEMORY PLAYBACK)
- REWINDING/FAST FORWARDING TAPE WHILE HEARING THE MESSAGES
- RECORDING A MARKER MESSAGE
- RESETTNG THE ICM TAPE FOR FUTURE MESSAGES
- MONITORING ROOM SOUND
- CHANGING THE OUTGOING MESSAGE
- SKIPPING THE OGM FOR ICM RECORDING
- SETTING/CANCELLING THE ANSWER MODE

---

## SETTING THE REMOTE CODE

---

To get remote access, you must set and remember your remote code number. The REMOTE CODE number is made up of 2 digits, the first digit is factory preset, and the second digit is selectable. ("2" or "8")

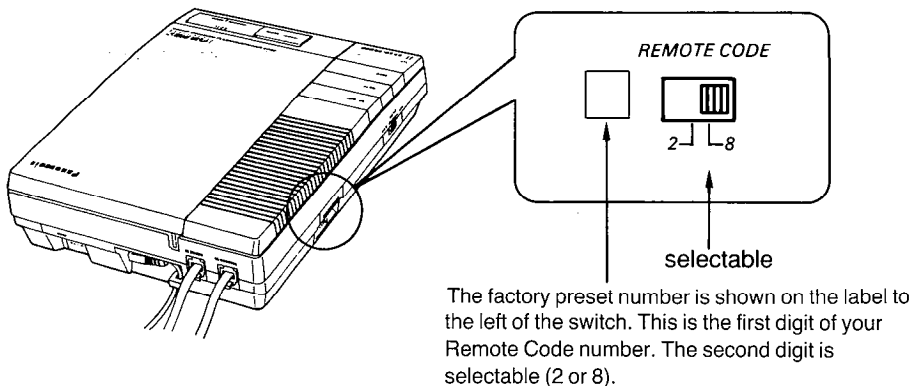

**EXAMPLE:** If the factory preset number is "4", then your code number may be either "42" or "48", depending on the position of the selectable REMOTE code switch.

---

## PLAYING BACK MESSAGES

---

You can listen to the recorded messages **by simply pushing your own code number.**

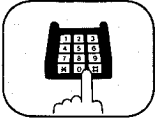

- 1 Call your unit, and push **the Code No.** (2 digits) during the OGM.
  - A beep will sound, then other beeps will sound to tell you the number of recorded messages, up to 8 times.
  - The unit will rewind the tape to the beginning. After a series of short beeps, you will hear all the messages on the tape.



- 2 Listen to the recorded messages.
  - 3 beeps will be heard after the last message.



- 3 Hang up.
  - All calls will be saved automatically.

---

## PLAYING BACK NEWLY-RECORDED MESSAGES (MEMORY PLAYBACK)

---

When you have already heard the messages from a remote phone, you can skip them and **listen to the newly-recorded messages.**

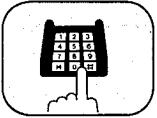

- 1 Call your unit, and push **the Code No.** during the OGM.



- 2 Push "4" right after you hear the beep tones indicating the number of the recorded messages.
  - The unit will play back the new messages.
  - Even during the playback of previously heard messages, you can skip them by pushing "4".

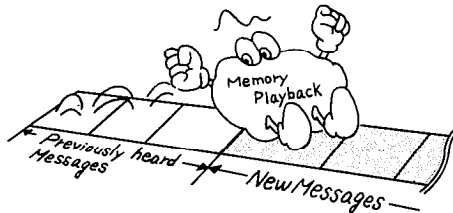



---

## REWINDING/FAST FORWARDING TAPE WHILE HEARING THE MESSAGES

---

### To Back Space

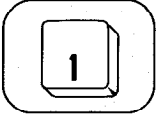

1 Push "1".

- The tape will be rewound for approximately 15 seconds corresponding to the playback time.

### To Skip Forward

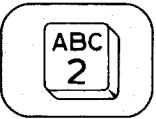

1 Push "2".

- The tape will be skipped forward for approximately 15 seconds corresponding to the playback time.

---

## RECORDING A MARKER MESSAGE

---

After reviewing all the messages, you can leave your index message on the tape. It can be heard by anyone retrieving messages.

1 Start to talk right after the last 2 beeps.

2 When recording is finished, hang up.

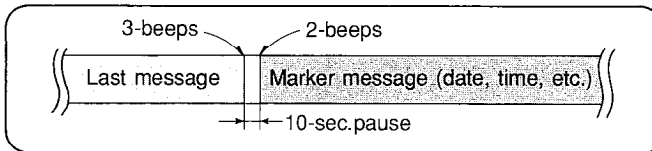

---

## RESETTING THE ICM TAPE FOR FUTURE MESSAGES

---

To record new Incoming Messages from the beginning of the tape, after the recorded messages are played back or while they are being played;

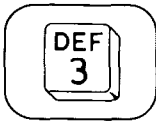

- 1 Push "3".
  - The unit will rewind the tape to the beginning and a beep tone will be heard when the tape has been reset.



After all the messages have been played back.

### If you have used Memory Playback



- 1 Push "3".
  - The unit will rewind the tape to the beginning of the **newly-recorded messages** and a beep will be heard.

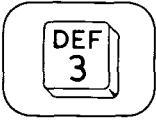

- 2 Push "3" again.
  - A beep tone will be heard and the future messages will be recorded from the beginning of the ICM tape.

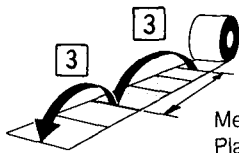

After you have used the Memory Playback.

### If you have reset the tape by mistake

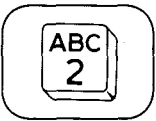

- 1 Push "2" after the tape has been reset (one-beep), then hang up.
  - The unit will advance the tape to the end of the recorded messages.

---

## MONITORING ROOM SOUND

---

You can screen any sound in the room where the unit is installed for 30 seconds.

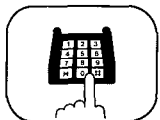

- 1 Call your unit and push the **Code No.** during the OGM.

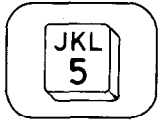

- 2 Push "5" right after you hear the beep tones indicating the number of the recorded messages.
  - You can listen for 30 seconds.
  - To listen further, push "5" again within 10 seconds of hearing one beep.

---

## CHANGING THE OUTGOING MESSAGE

---

You can re-record the Outgoing Message from a remote phone.

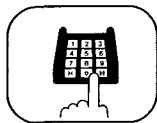

- 1 Call your unit, and push **the Code No.** during the OGM.



- 2 Push “7” right after you hear the beep tones indicating the number of recorded messages.
- Short beeps will be heard continuously until the OGM tape has been reset, and then a long beep will be heard.



- 3 Speak clearly and loudly after you hear the long beep.



- 4 When recording is finished, push “9”.
- The new Outgoing Message will be played back. So you can check or amend it.

### NOTE:

If you pause for over 2 seconds while recording, you will hear a series of warning tones (6 beeps). If this happens, push “7” within 10 seconds of hearing these beeps, and repeat from step 2 again.

---

## SKIPPING THE OGM FOR ICM RECORDING

---

If you or the caller does not want to hear the Outgoing Message, the unit **can be switched promptly to the Incoming Message mode.**



- 1 Call your unit.

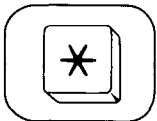

- 2 Push “\*” during the OGM.



- 3 **Speak** clearly and loudly after you hear the long beep to record your Incoming Message.

---

## SETTING/CANCELLING THE ANSWER MODE

---

You can easily set or cancel the Answer mode from a remote phone.

### To Set

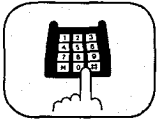

1 Call your unit.



2 Wait for **15 rings**.  
●OGM will be heard, then hang up.  
●The unit will be ready to answer the next phone call.

### To Cancel

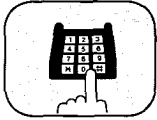

1 Call your unit, and push **the Code No.** (2 digits) during the OGM.

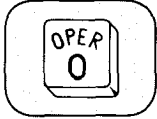

2 Push **"0"**.  
●The unit will not pick up any calls.

# Troubleshooting Guide

---

## Problem

## Cause & Remedy

<ul style="list-style-type: none"><li>●The unit does not work when I push any buttons.</li><li>●I cannot remove the cassette from the unit.</li></ul>	Plug in the AC adaptor then switch the power on.
The unit has been set to the Answer mode, but no Incoming Message is recorded.	<ul style="list-style-type: none"><li>●The OGM or ICM cassette is cut or is not inserted. Replace the cassette with a new one.</li><li>●The OGM is recorded improperly. Record a new OGM.</li></ul>
The unit does not function. However, the beep sounds 6 times and the ANSWER/CALL indicator flashes on and off quickly.	<ul style="list-style-type: none"><li>●OGM cassette might be broken. Replace it with a new one.</li><li>●Clean the heads. (See page 24.)</li></ul>
While recording an Outgoing Message, the beep sounds 6 times.	Re-record your Outgoing Message. Speak clearly and loudly, and do not pause for over 2 seconds while recording.
When the Outgoing Message or the Incoming Message tape is played back, the sound level is low, even if the VOLUME control is turned up fully.	<ul style="list-style-type: none"><li>●Clean the Heads. (See Maintenance instruction on page 24.)</li></ul>
I have played back all the recorded messages and I want to record the next phone call after the last previously recorded message.	<ul style="list-style-type: none"><li>●Wait for 7 seconds. The unit will be ready to record the next phone call.</li><li>●In case of the remote operation, just hang up.</li></ul>
I push the button of a remote phone, but the unit does not respond.	<ul style="list-style-type: none"><li>●Make sure that you are entering your correct Code number.</li><li>●Record the Outgoing Message in a quiet place.</li></ul>
Some Incoming Messages have not been recorded up to their end.	Set the CPC switch to "B". (See page 5.)
The ICM tape continues to run after a caller hangs up.	Set the recording time selector to "1 MIN".

# Referencia Rápida

---

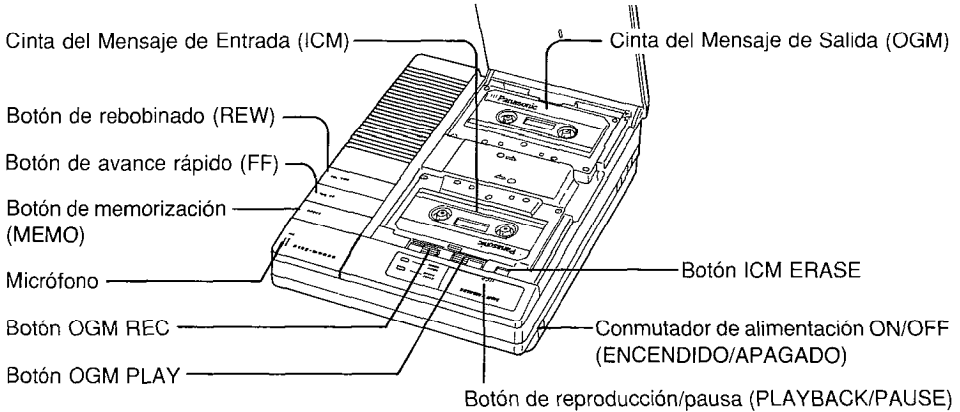

---

## PUESTA DE LA CINTA DEL CASETE

---

- 1 Abra el panel e inserte las cintas OGM e ICM.
  - 2 Conecte el adaptador de CA en el terminal de CA.
  - 3 Coloque el conmutador **POWER ON/OFF** en la posición **ON**.
- Cuando cambie la cinta OGM: presione los botones **OGM PLAY** y **REW** simultáneamente.

---

## GRABACIÓN DEL MENSAJE DE SALIDA

---

- 1 Presione **OGM REC** hasta que se escuche un pitido largo, luego deje de presionarlo.
- 2 Hable con voz clara y firme por el MIC.
  - El tiempo de grabación OGM varía según la duración de la cinta empleada.
  - No haga pausas de más de 2 segundos mientras graba.
- 3 Cuando acabe de hablar, presion el **OGM REC**.

---

## VERIFICACIÓN DEL MENSAJE DE SALIDA

---

- 1 Presione el **OGM PLAY** para confirmar el mensaje de salida.
  - La unidad reproducirá el Mensaje de Salida y luego rebobinará la cinta hasta el comienzo.
  - La unidad cambiará automáticamente a la Modalidad de contestación después de 7 segundos de la reproducción del MS.

---

## **PARA ESCUCHAR LOS MENSAJES**

---

Cuando el teléfono suene, la unidad reproducirá el mensaje de salida (OGM) y luego grabará el mensaje de la persona que llama en la cinta.

1 Presione el **PLAYBACK/PAUSE** (Reproducción/Pause).

### ■ **Auto-Lógico (Función de un solo toque)**

Un solo toque del botón **PLAYBACK/PAUSE** hace posible que la unidad reproduzca los mensajes y suene 3 pitidos después del último mensaje. Luego, después de diez segundos, la unidad rebobinará la cinta y estará lista para grabar nuevos mensajes desde el comienzo de la sección ICM de la cinta.

---

## **MEMORIZACIÓN DEL MENSAJE**

---

Para grabar un mensaje que va a ser oído por alguien usando el control remoto.

1 Presione el **MEMO** hasta que suene un pitido.

2 Hable por el MIC.

3 Cuando termine, presione el **MEMO**.

---

## **MONITOREO DE LOS MENSAJES DE LLEGADA**

---

Usted puede escuchar el mensaje de llegada mientras se esté grabando.

1 Ajuste el control de volumen.

- Si desea hablar a la persona que llama durante la grabación del mensaje, levante el microteléfono y hable.

---

## **ALMACENAMIENTO DEL MENSAJE GRABADO**

---

1 Reproduzca la cinta hasta el mensaje que desee almacenar.

2 Presione el **PLAYBACK/PAUSE** para hacer una pausa.

- El indicador IN USE destellará.

3 Presione el **PLAYBACK/PAUSE** y **REW** simultáneamente.

- El indicador IN USE dejará de destellar.

---

## **BORRADO DE LOS MENSAJES GRABADOS**

---

1 Presione **ICM ERASE**.

- La unidad rebobinará la cinta y a la vez, la unidad borrará los mensajes previos. Los nuevos mensajes serán grabados desde el comienzo de la cinta.

---

## PARA ESCUCHAR MENSAJES DESDE OTRO TELEFONO A DISTANCIA

---

No. de código es de dos dígitos.

El primer dígito es preajustado en la fábrica y el segundo lo seleccionará Ud.

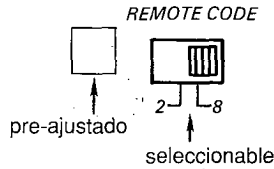

### Control Remoto del Tono

- 1 Marque el número de teléfono con sólo un tono telefónico.
  - 2 Cuando empiece el mensaje de salida, presione el número de código (2 dígitos) firmemente y sonará otro pitido.
    - Sonará un pitido para decirle el número de mensajes grabados.
    - El contestador rebobinará la cinta de los mensajes de salida y los reproducirá.
    - Después de haberse reproducido el último mensaje, sonará 3 pitidos.
  - 3 Cuelgue el microteléfono.
    - El mensaje siguiente se grabará después del último mensaje.
    - Para grabar el mensaje de llegada (ICM) desde el comienzo de la cinta, pulse el botón "3" y cuelgue el teléfono.
- **Retrosceso:**  
Presione el botón "1" para rebobinar unos 15 segundos de la cinta y reproducirla.
- **Avance por salto:**  
Presione el botón "2" para hacer que la cinta avance unos 15 segundos y para reproducirla.



# Maintenance

Because the head and capstan assemblies are in contact with the tape, dirt and residue from the tape can easily adhere to these parts, causing distortion. These parts should be cleaned periodically in the manner described below.

● **Clean the head surface, pinch roller and capstan with a cotton swab.**

If these surfaces are extremely dirty, dampen the cotton swab with alcohol.

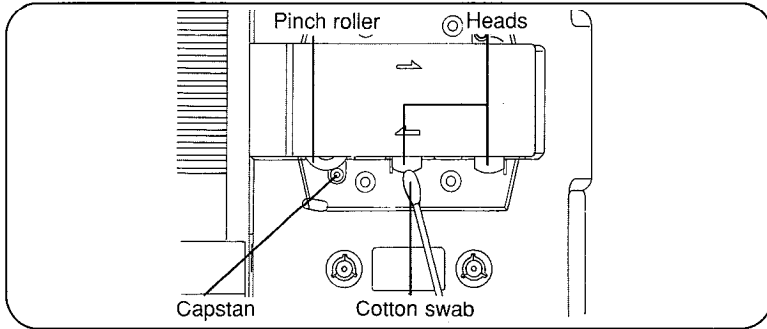

- Do not bring magnetic or metal objects, such as a screwdriver, near the head assemblies, as such objects could magnetize the heads.
- Do not oil any part of the unit.

## Cassette Tape

- For optimum sound quality and performance, we recommend that you **use side two after six months and replace the tape every year** assuming that the unit answers about ten calls a day.
- Should the cassette tape break or become worn, replace it with a high quality "NORMAL" tape. Use Panasonic (C30, C60, C90), TDK or MAXELL cassette tape. Metal or chrome tape cannot be used.
- Never place a cassette tape near a magnetic source, such as a magnet or a TV set, because it may erase the tape.
- Slack in the tape can be tightened by rotating the tape reel with a pencil, as shown.

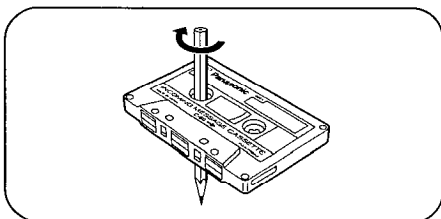

### QUICK REFERENCE CARD FOR TONE REMOTE CONTROL

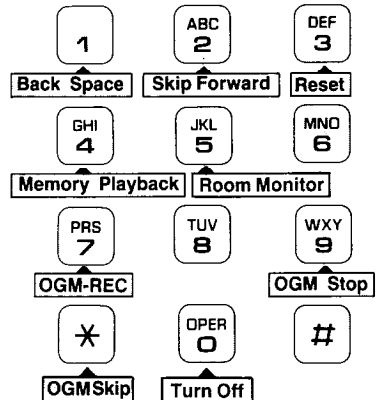

■ To set to the Answer mode remotely

1. Dial the phone number.

2. Wait until 15 rings and hang up.

■ To turn off the unit remotely

1. Dial the phone number.

2. Push [Code No.] [Listen to a beep] 0 and then hang up.

# Others

- If there is any trouble, disconnect the unit from the telephone line and connect a known working phone. If the known working phone operates properly, have your Panasonic unit repaired by one of the specified Panasonic Factory Service Centers. If the known working telephone does not operate properly, consult with your telephone company.
- Do not use benzine, thinner, or similar solvents. Do not use abrasive powder to clean the cabinet. Wipe it with a soft cloth.
- Keep the unit away from heating appliances and electrical noise generating devices such as fluorescent lamps, motors and television. These noise sources can interfere with the performance of the unit.
- The unit should be kept free of dust, moisture, high temperature and vibration, and should not be exposed to direct sunlight.
- Never attempt to insert wires, pins, etc. into the vents or other holes of this unit.

## Accessory Order Information

- Replacement parts and accessories are available through your local authorized parts distributor.
- For the authorized distributors in your area, call toll free: 1-800-545-2672

Part No.	Description	Comment
KX-C300	OGM Tape	
KX-C600	ICM Tape	

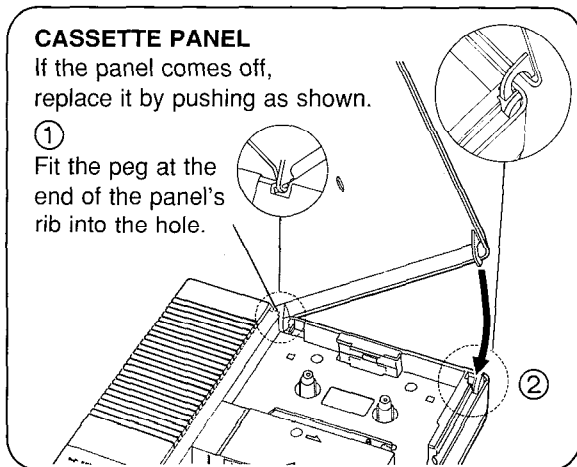
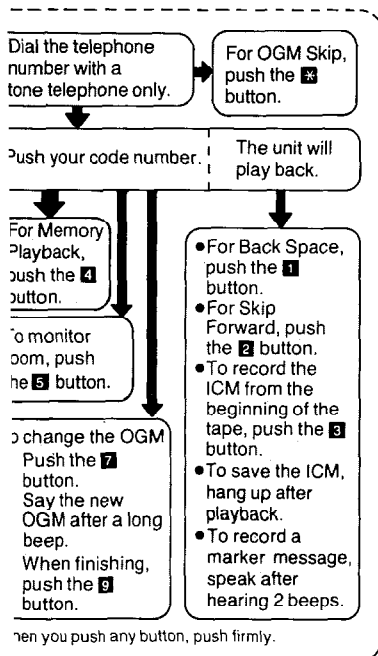

# Important Information

---

If requested by the Telephone Company, inform them as follows:

- FCC Registration No. . . . . . (found on the bottom of the unit)
- Ringer Equivalence . . . . . 0.4 B
- The particular telephone line to which the equipment is connected.

In the event terminal equipment causes harm to the telephone network, the telephone company should notify the customer, if possible, that service may be stopped.

However, where prior notice is impractical, the company may temporarily cease service providing that they:

- (a) Promptly notify the customer.
- (b) Give the customer an opportunity to correct the problem with their equipment.
- (c) Inform the customer of the right to bring a complaint to the Federal Communication Commission pursuant to procedures set out in F.C.C. Rules and Regulations Subpart E of Part 68.

The Telephone Company may make changes in its communications facilities, equipment, operations or procedures, where such action is reasonably required in the operation or its business and is not inconsistent with the rules and regulations in F.C.C. Part 68.

If such changes can be reasonably expected to render any customer terminal equipment incompatible with telephone company communications facilities, or require modification or alteration of such terminal equipment, or otherwise materially affect its use or performance, the customer shall be given adequate notice in writing, to allow the customer an opportunity to maintain uninterrupted service.

“This equipment has been tested and found to comply with the limits for a Class B computing device in accordance with the specifications set forth in Subpart J of Part 15 of the F.C.C. Rules.

If this equipment does cause interference to radio or television reception which can be determined by turning the equipment on and off, use the equipment in another location and/or utilize an electrical outlet different from that use by the receiver.”

## **Ringer Equivalence No. (REN):**

The REN is useful in determining the quantity of devices you may connect to your telephone line and still have all of those devices ring when your telephone line and still have all of those devices ring when your telephone number is called. In most, but not all areas, the sum of the REN's of all devices connected to one line should not exceed five (5.0). To be certain of the number of devices you may connect to your line, as determined by the REN, you should contact your local telephone company to determine the maximum REN for your calling area.

## **WARNING:**

TO PREVENT FIRE OR SHOCK HAZARD, DO NOT EXPOSE THIS PRODUCT TO RAIN OR ANY TYPE OF MOISTURE.

# Servicenter Directory

To locate an Authorized Servicenter in your area within the U.S.A.  
**DIAL TOLL FREE: 1-800-545-2672**

24 Hours a Day, 7 Days a Week

Consumers requiring assistance with service matters should contact the appropriate Regional Administration Office:

**NORTHEAST**

2250 Cabot Blvd., West  
Langhorne, PA 19047  
215-741-0676

**MIDWEST**

425 East Algonquin Road  
Arlington Heights, IL 60005  
708-981-4842

**WESTERN**

6550 Katella Avenue  
Cypress, CA 90630  
714-373-7440

**SOUTHERN**

1854 Shackelford Court,  
Suite 4105  
Norcross, GA 30093  
404-717-6860

**Covers:**

CT, DE, ME, MD, MA, NH,  
NJ, NY, PA, RI, VT, VA,  
DC, WV, Eastern OH

**Covers:**

IL, IN, IA, KS, KY, MI,  
MN, MO, NE, ND, SD, WI,  
Western OH

**Covers:**

AK, AZ, CA, CO, ID, MT,  
NV, NM, OR, UT, WA, WY,  
HI

**Covers:**

AL, AR, FL, GA, LA, MS, NC,  
OK, SC, TN, TX

Consumers requiring product information of operating assistance with a consumer product should contact:

**CONSUMER AFFAIRS DEPARTMENT 2F-3**

50 Meadowland Parkway, Secaucus, N.J. 07094 (201) 348-9090

Your product is designed and manufactured to ensure a minimum of maintenance. However, should your unit ever require service, a nationwide system of FACTORY SERVICENTERS and AUTHORIZED INDEPENDENT SERVICENTERS is maintained to support your product's warranty.

Service in the U.S.A....

Factory Servicenters

**MATSUSHITA SERVICES COMPANY**

Division of Matsushita Electric Corporation of America

50 Meadowland Parkway, Secaucus, New Jersey 07094

**ALABAMA**

2523-5th Avenue, South  
Birmingham, AL 35233  
205-252-4195

**CALIFORNIA**

6550 Katella Avenue  
Cypress, CA 90630  
714-373-7426  
930 South Mt. Vernon Ave.  
Suite 200

Colton, CA 92324  
714-825-3110  
800 Dubuque Avenue  
So. San Francisco,  
CA 94080

415-871-6373  
20201 Sherman Way  
Suite 102

Canoga Park, CA 91306  
818-709-1775

3878 Ruffin Rd., Suite A  
San Diego, CA 92123  
619-560-9200

**COLORADO**

1640 South Abilene  
Suite D  
Aurora, CO 80012  
303-752-2024

**FLORIDA**

4115 W. Kennedy Boulevard  
Tampa, FL 33609  
813-289-9726

**GEORGIA**

4245 International Blvd.  
Suite C  
Norcross, GA 30093  
404-717-6880

**HAWAII**

99-859 Iwaiwa Street,  
Aiea, HI 96701  
808-488-1996

**ILLINOIS**

425 E. Algonquin Road  
Arlington Heights, IL 60005  
708-981-4840

**MARYLAND**

Sulphur Spring Business  
Park,  
1638 Sulphur Spring Road,  
Baltimore, MD 21227  
301-242-2807

**MASSACHUSETTS**

383 University Avenue  
Westwood, MA 02090  
617-329-4280

**MICHIGAN**

8760 Hall Road  
Rosati Heights Plaza  
Sterling Heights, MI 48314  
313-739-1330

**MINNESOTA**

7850-12th Avenue, South  
Airport Business Center,  
Bloomington, MN 55425  
612-854-8624

**MISSOURI**

11982 Dorsett Road  
Maryland Heights,  
MO 63043  
314-739-5301  
**OHIO**  
1196 W. Kemper RD  
Cincinnati, OH 45240  
513-851-4180

**PENNSYLVANIA**

2250 Cabot Blvd., West  
Langhorne, PA 19047  
215-741-0661  
Campbell's Run  
Business Center  
500 Business Center Drive  
Pittsburgh, PA 15205  
412-788-2174

**TENNESSEE**

919-8th Avenue, South  
Nashville, TN 37203  
615-244-4434

**TEXAS**

7420 Harwin Drive  
Houston, TX 77036  
713-781-1528  
4500 Amon Carter Blvd.  
Fort Worth, TX 76155  
817-685-1060  
**WASHINGTON**  
20425-84th Ave., South  
Kent, WA 98032  
206-872-7922

Service in Puerto Rico

**MATSUSHITA ELECTRIC OF PUERTO RICO, INC.**

Panasonic Sales Company/Factory Servicenter

San Gabriel Industrial Park, 65th Infantry Avenue KM 9.5 Carolina, Puerto Rico 00630 (809) 750-5135

---

## ***Panasonic Telephone Products Limited Warranty***

---

Panasonic Company, Panasonic Company (West) of America or Panasonic Sales Company (collectively referred to as "Panasonic") will repair this product with new or rebuilt parts, free of charge, in the U.S.A. or Puerto Rico for one (1) year from the date of original purchase in the event of a defect in material or workmanship.

Carry-in or mail-in service in the U.S.A. can be obtained during the warranty period from a Matsushita Services Company (MSC) Factory Servicenter listed in the Servicenter Directory. Or call 1-800-545-2672, toll free, to locate an authorized MSC Servicenter. Carry-in or mail-in service in Puerto Rico can be obtained during the warranty period by calling the telephone numbers listed in the Servicenter Directory. This warranty is extended only to the original purchaser. A purchase receipt or other proof of date of original purchase will be required before warranty performance is rendered. This warranty only covers failures due to defects in materials or workmanship which occur during normal use. It does not cover damage which occurs in shipment or failures which are caused by products not supplied by Panasonic or failures which result from accident, misuse, abuse, neglect, mishandling, misapplication, alteration, modification, or commercial use of the product, or service by anyone other than an MSC Factory Servicenter or authorized MSC Servicenter, or damage that is attributable to acts of God.

---

### ***Limits and Exclusions***

---

There are no express warranties except as listed above. PANASONIC SHALL NOT BE LIABLE FOR INCIDENTAL OR CONSEQUENTIAL DAMAGES RESULTING FROM THE USE OF THIS PRODUCT, OR ARISING OUT OF ANY BREACH OF THIS WARRANTY. ALL EXPRESS AND IMPLIED WARRANTIES, INCLUDING THE WARRANTIES OF MERCHANTABILITY AND FITNESS FOR A PARTICULAR PURPOSE, ARE LIMITED TO THE APPLICABLE WARRANTY PERIOD SET FORTH ABOVE. Some states do not allow the exclusion or limitation of incidental or consequential damages, or limitations on how long an implied warranty lasts, so the above exclusions or limitations may not apply to you.

This warranty gives you specific legal rights and you may also have other rights which vary from state to state. If a problem with this product develops during or after the warranty period, you may contact your dealer or Servicenter. If the problem is not handled to your satisfaction, then write to the Consumer Affairs Division at the company address indicated back cover.

***If you ship the product***

Carefully pack and send it prepaid, adequately insured and preferably in the original carton.  
Attach a postage-paid letter, detailing the complaint, to the outside of the carton.  
*DO NOT send the product to the Executive or Regional Sales offices. They are NOT equipped to make repairs.*

***Product Service***

Panasonic Servicenters for this product are listed on page 27.  
Consult your authorized Panasonic dealer for detailed instructions.

***For your future reference***

Serial No. \_\_\_\_\_ (found on the bottom of the unit)

Name of Dealer \_\_\_\_\_

Date of Purchase \_\_\_\_\_

Dealer's Address \_\_\_\_\_



— PANUG-020

**Panasonic Company,  
Division of Matsushita Electric Corporation of America**  
One Panasonic Way, Secaucus, New Jersey 07094

**Panasonic Company (West) of America,  
Division of Matsushita Electric Corporation of America**  
6550 Katella Avenue, Cypress, California 90630

**Panasonic Sales Company ("PSC"),  
Division of Matsushita Electric of Puerto Rico, Inc.**  
San Gabriel Industrial Park, 65th Infantry Avenue, KM 9.5, Carolina, Puerto Rico 00630