

Section 200

General Description

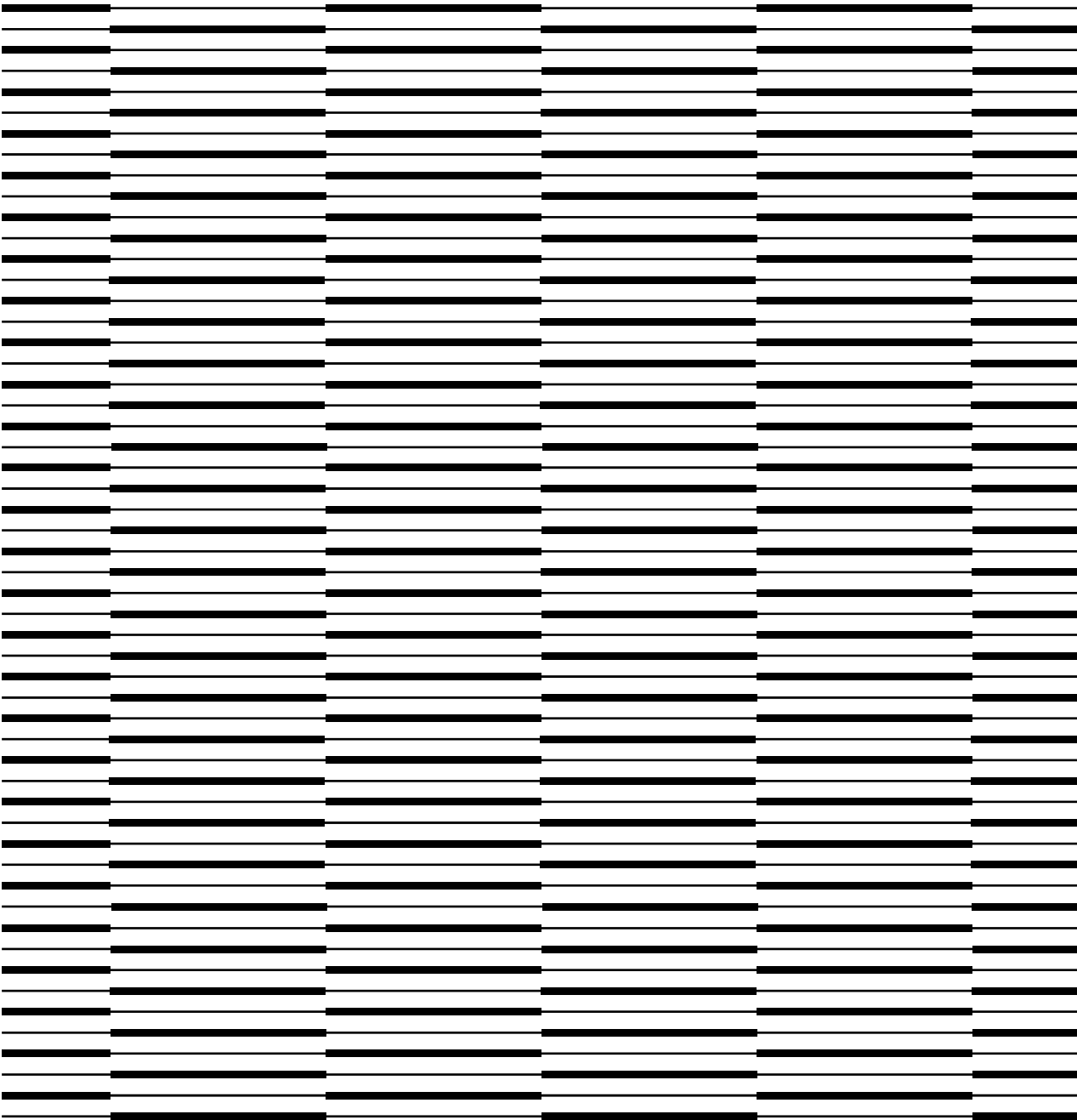

The contents of this document are subject to change without notice and do not constitute a commitment on the part of Matsushita Communications Industrial Co, Ltd (MCI) Every effort has been made to ensure the accuracy of this document. However, due to ongoing product improvements and revisions, Panasonic cannot guarantee the accuracy of printed material after the date of publication, nor can it accept responsibility for errors or omissions. Panasonic will update and revise this document as needed.

The software and hardware described in this document may be used or copied only in accordance with the terms of the license pertaining to said software or hardware.

© 1998 by Matsushita Communications Industrial Co., Ltd. (MCI)

All rights reserved.

Panasonic Telecommunications Systems Company
Business Telephone Systems Division

Publication Information

At the time of this document's publication, the covered product (DBS 576) was still under development. Although every effort was made to present this product as accurately as possible, the information contained in this document is subject to change without notice and should not be construed as a commitment by the Panasonic Telecommunications Systems Company (PTSC). PTSC reserves the right, without notice, to make changes to equipment design as advances in engineering and manufacturing methods warrant.

The software and hardware described in this document may be used or copied only in accordance with the terms of the license pertaining to said software or hardware.

Reproduction, publication, or duplication of this manual or any part thereof, in any manner mechanically, electronically, or photographically, is prohibited without permission of PTSC.

©Copyright 1997 by Panasonic Telecommunications Systems Company, Division of Panasonic Communications & Systems Company, a unit of Matsushita Electric Corporation of America.

Win32s, Windows, Windows 95, and Windows NT are either trademarks or registered trademarks of Microsoft Corporation in the United States and/or other countries.

Reference to third-party products is for information only and does not constitute an endorsement or recommendation. Panasonic does not assume responsibility for the performance of third-party products.

PREFACE - REQUIREMENTS

OVERVIEW

This section provides information the telephone company may require before providing you with service. Additionally, important notices and warnings are listed for your knowledge and safety.

FCC REGISTRATION NUMBERS

The Federal Communications Commission (FCC) has established rules which permit the DBS 576 to be directly connected to the telephone network. To ensure that the DBS 576 complies with these FCC rules, the local telephone company may ask you for the FCC registration numbers when attaching their equipment to the DBS 576.

The DBS 576 can be configured as either a KEY or PBX telephone system. The way you register your system depends on how you use the system. First, determine how you will be operating the system, and then refer to the table below for FCC registration numbers. The following tables also list additional information that may be required by your local telephone company.

KEY Operation

A KEY system requires you to manually select an outside line to make an outgoing call. Typically, line keys on a telephone represent the specific lines that are attached to the system (for example, Key 1 represents line 1; Key 2 represents line 2; etc.).

PBX Operation

A PBX system allows automatic selection of outgoing lines, such as pooled key operation, dial access, least cost routing (LCR), etc. (for example, depress a key to select from a pool of lines; or dial 9 to select an outside line).

REGISTRATION INFORMATION (DBS values shown below - DBS 576 t/b plugged in later)

System	Operation	Ringer Equivalence	Network Address Signaling Code	FCC Registration
DBS 576	KEY	.5B*	E	xxxxxn-nnnnn-xx-x
DBS 576	PBX	.5B*	E	xxxxxx-nnnnn-xx-x

* The Ringer Equivalence Number (REN) is used to determine how many devices can be connected to your telephone line. In most areas, the sum of the RENs of all devices on any one line should not exceed five (5.0). If too many devices are attached, they may not ring properly.

INTERFACE INFORMATION

The DBS 576 offers several types of interface cards that allow you to connect to different circuits offered by your telephone company. Listed below is additional information that the telephone company may require before providing you with these different services.

REGISTRATION INFORMATION (DBS info shown - DBS 576 t/b plugged in later)

Port Type	Type of Interface	USOC Jack Connector	Service Order Code	Facility Interface Code
Loop Start Trunk	2-wire loop	RJ21X	9.0F	02LS2
Ground Start Trunk	2-wire ground	RJ21X	9.0F	02GS2

Port Type	Type of Interface	USOC Jack Connector	Service Order Code	Facility Interface Code
DID Trunk	2-wire DID	RJ21X	9.0F	02RV2-T
T-1 Trunk	T-1	RJ48C	6.0F	04DU9-DN, 04DU9-1SN
ISDN	T-1	RJ48C	6.0F	04DU9-DN, 04DU9-1SN
E&M	Type I 2-wire Type I 4-wire Type II 2-wire Type II 4-wire	RJ1CX	9.0F	TL11M, 2-wire TL31M, 4-wire TL12-Type II, 2-wire TL32-Type II, 4-wire

DIRECT INWARD DIALING (DID) REQUIREMENTS

Operating this equipment in a manner that does not provide for proper answer supervision is a violation of Part 68 of the FCC Rules. Proper answer supervision occurs if this equipment returns answer supervision to the Public Switched Telephone Network (PSTN) when DID calls are:

- Answered by the called station
- Answered by the attendant
- Routed to a recorded announcement that can be administered by the Customer Premise Equipment (CPE) user
- Routed to a dial prompt.

T-1 REQUIREMENTS

This device must only be attached to the T-1 network connected behind an FCC Part 68 registered Channel Service Unit (CSU). Direct connection is not allowed.

ADDITIONAL PRECAUTIONS

- If the unit appears to be malfunctioning, it should be disconnected from the telephone lines until you determine if either your equipment or the telephone line is the source of the problem. If your equipment needs repair, it should not be reconnected until it is repaired.
- If the telephone company finds that this equipment is exceeding tolerable parameters, the telephone company may temporarily disconnect service, although they will attempt to give you advance notice if possible.
- Under the FCC Rules, no customer is authorized to repair this equipment. This restriction applies regardless of whether the equipment is in or out of warranty.
- The goal of the telephone company is to provide the best service it can. In order to do this, it may occasionally be necessary for them to make changes to their equipment, operations, or procedures. If these changes might affect your service or the operation of your equipment, the telephone company will give you notice, in writing, to allow you to make any changes necessary to maintain uninterrupted service.
- This equipment is capable of providing users access to interstate provider of operator services through the use of access codes. Modification of this equipment by call aggregators to block access dialing codes is a violation of the Telephone Operator Consumers Act of 1990.
- If you experience trouble with the DBS 576, please contact your Panasonic DBS authorized service provider for repair/warranty information. The telephone company may ask you to disconnect this equipment from the network until the problem has been corrected.

FCC WARNING

This equipment generates, uses, and can radiate radio frequency energy, and, if not installed and used properly, that is, in strict accordance with the instruction manual, may cause interference to radio and television reception. This equipment has been tested and found to comply with the limits for a Class A computing device in Subject J of Part 15 of FCC Rules, which are designed to provide reasonable protection against such interference in a residential installation. However, there is no guarantee that interference will not occur in a particular installation. If this equipment does cause interference, correct by one or more of the following measures:

1. Reorient the receiving antenna,
2. Relocate the key service unit and key telephones with respect to the receiver,
3. Move the equipment from the receiver,
4. Plug the key service unit into a different outlet so that the equipment and receiver are on different branch circuits.

BATTERY RECYCLING STATEMENT



The following statement applies if you purchased backup batteries with your system.

THE PRODUCT YOU HAVE PURCHASED MAY CONTAIN SEALED LEAD ACID BATTERIES WHICH ARE RECYCLABLE. AT THE END OF THEIR USEFUL LIFE, UNDER VARIOUS STATE AND LOCAL LAWS, IT IS ILLEGAL TO DISPOSE OF THESE BATTERIES INTO YOUR MUNICIPAL WASTE STREAM. PLEASE CALL 1-800-SAV-LEAD FOR INFORMATION ON HOW TO RECYCLE THESE BATTERIES.

IMPORTANT NOTICE: MUSIC-ON-HOLD SOURCE

In accordance with U.S. Copyright Law, a license may be required from the American Society of Composers, Authors and Publishers (ASCAP), or other similar organization, if radio or TV broadcasts are transmitted through the music-on-hold connection on this DBS 576 product. Panasonic Information & Communications Company/Business Telephones Systems Division, hereby disclaims any liability arising out of failure to obtain such a license.

TABLE OF CONTENTS

TABLE OF CONTENTS	3
--------------------------------	----------

CHAPTER 1 - SYSTEM OVERVIEW

Introducing the Next-Generation Phone System from Panasonic	7
System Technology	9
Power Requirements	9
Diagnostic Maintenance	9
Programming The Phone System	10
Supporting Documentation	10

CHAPTER 2 - SYSTEM HARDWARE

Overview	13
Cabinets.....	13
Common Cards.....	13
Telephone Company Interface Equipment.....	13
Station Interface Equipment	13
Optional and Miscellaneous Equipment	13
Station Equipment	13
System Hardware Connections	13
Cabinets	15
CAB-40 Base Cabinet (VB-44010)	15
CAB-96 Base Cabinet (VB-44020)	15
CAB-96B Expansion Cabinet (VB-44021)	16
Battery Backup (VB-44025)	17
Switch Box (VB-44023).....	17
Control Unit	17
CPC-96 (VB-44410).....	17
CPC-288 (VB-444201).....	17
CPC-576 (VB-444301).....	17
Time Switch - TSW-288 (VB-444202)	17
Time Switch - TSW-576 (VB-444302)	18
Connection Cable Kit - CBL Kit (VB-44450)	18
Building Block Expansion Cable Kit - CBL (VB-44451)	19
ICX to DBS Expansion Cable Kit - CBLDBS (VB-44452)	19
Network Synchronizing Unit - SYNC (VB-44460)	19
Trunk Line Cards	20
Loop Start Card - LS (VB-44510)	20
Primary Rate Interface Card (T-point) - PRI (VB-44540).....	20
Basic Rate Interface Card (S-point) - BRI (VB-44530)	20
Extension Cards	21
Digital Extension Card - DEC (VB-44610)	21
Analog Extension Unit (VB-44520)	21

BRI Unit (S-point) (VB-44630)	21
Primaty Rate Interface Card (S-point)-PRI (VB-44540)	21
Options	21
MFR Card (VB-44110)	21
8-Party Conference Card (VB-44120)	21
Built-In ACD Card (VB-44140)	21
Built-In Voice Mail Voice Storage Card (VB-44170)	22
Voice Processing Card (4 circuits) (VB-44160)	22
Voice Processing Card (8 circuits) (VB-44150)	22
SCC Unit (VB-44181)	22
Power Failure Transfer Unit (VB-43703)	23
1 Line SLT Adaptor (VB-44100)	23
Station Equipment	23
Overview	23
Model Options	24
Model Descriptions	24
Digital Single Line Telephone (VB-41200)	24
12 Key Speakerphone (VB-44221)	25
12 Key Display Speakerphone (VB-44223)	25
12 Key Display Speakerphone with Voice Response - (VB-44224)	25
12 Key Large Screen Display Speakerphone- (VB-44225)	25
24 Key Display Speakerphone (VB-44233)	26
24 Key Expansion Module (VB-44310)	26
72 Button DSS/BLF (VB-44320)	26
Optional Terminal Devices	26
Voice Recognition Unit Adapter (VB-44101)	26
PC Phone (VB-44332) (Future Feature)	26
PC Attendant Console/96 (VB-44330) (Future Feature)	27
PC Attendant Console/384 (VB-44331) (Future Feature)	27
Telephone Key Layout	28

CHAPTER 3 - SYSTEM FEATURES **33**

Popular System Features	33
Auto Day/Night Mode	33
Automatic Route Selection (ARS)	33
Call Traffic Reporting	34
Caller ID (CID)	34
Class of Service (COS) Restriction	34
Computer Telephony Integration (CTI)	35
Conferencing	35
Data Security	35
Delayed Ringing	36
Direct Inward System Access (DISA)	36
Distinctive Ringing	36
Flexible Dial Plan	36
Flexible Ringing Assignment	37
“Howler” Tone	37
Hunt Groups	37
Multiple Direct Inward Dial (DID) Assignment (for ISDN)	38
Recall Timers	38

Slide Ringing.....	38
Station Message Detail Recording (SMDR)	39
System Speed Dialing (SSD).....	40
Toll Restriction Service (TRS).....	41
Walking TRS.....	41
List of Available System Features	42

CHAPTER 4 - STATION FEATURES 45

Overview.....	45
Popular Station Features	45
Account Code Capability	45
Alarm Ringing	46
Alarm Tone for Lengthy Calls.....	46
Attendant Calling	46
Auto-Repeat Dialing.....	47
Background Music (BGM).....	47
Busy Override (“Barge-In”)	47
Call Duration Display	48
Call Forwarding.....	48
Call Park	48
Call Pick-up.....	49
Caller ID Call log.....	49
Callback Request.....	49
Camp-On (Call Waiting).....	50
Conference Calls	50
Do-Not-Disturb (DND).....	50
DP-to-DTMF Signal Conversion	50
DSS/BLF Keys.....	51
Dual-Color LEDs.....	51
Flexible Feature Keys (“FF-Keys”).....	51
Hands-Free Answerback	52
Headset Capability.....	52
Hold	52
Hot Line	53
Meet-Me Answer.....	53
Message-Waiting/Callback	53
Mute.....	53
Name Assignment	54
Off-Hook Monitoring	54
Off-Hook Signaling.....	54
On-Hook Dialing	54
Off-Hook Voice Announce (OHVA)	55
One-Touch Keys	55
Paging.....	55
Prime Line Preference	55
Ringling Line Preference	56
Soft Key Variable Mode	56
Speed Dialing	56
Transfer	56

List of Available Station Features57

CHAPTER 5 - SPECIAL APPLICATIONS 61

Overview61
Computer Telephony Integration (CTI) (Future Feature).....61
 PC Phone61
 PC Attendant Console62
Voice Mail64
 Built-In Voice Mail with 2-Way Call Recording64
Automatic Call Distribution (ACD)64
 Built-In ACD64

CHAPTER 6 - SPECIFICATIONS 67

Overview67
 Electrical Characteristics67
 Environmental Requirements67

CHAPTER 1 - SYSTEM OVERVIEW

INTRODUCING THE NEXT-GENERATION PHONE SYSTEM FROM PANASONIC

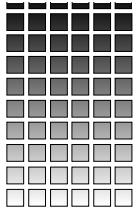

Our telephony customers know what they're looking for -- real product solutions to meet the very real demand for an effective, responsive, user-friendly telephone system. They know that the phone system is their most important link to the outside world -- and often their "welcome mat" for it. They're dead in the water without a good one.

To provide them with such a phone system, they need a company who's already out there on the front lines. With a solid reputation for reliability. Flexibility. Feature-rich options. Expansion capability. New technology, smartly applied. And all of this at an affordable price.

We hear you, loud and clear.

As the world's largest consumer electronics company, Matsushita Electronics (Panasonic's parent company) has established a worldwide reputation for solid reliability and innovative design in their products. And true to form, Panasonic's Communications division has become a major world-class manufacturer of electronic telecommunications products.

With the Digital Business Systems product line, we're currently one of the largest suppliers of business telephone systems. Our products are known for their cost-effective digital technology, dependable functionality, and user-oriented design.

And we're listening to them. They're asking for a phone system that can expand to accommodate a larger phone base. They want ISDN. Computer Telephony Integration. Automatic Call Distribution. Two-way call recording. Networking. Voice recognition.

We make it better.

So we responded. As a result, Panasonic is proud to introduce the next-generation phone system in the DBS product line -- the **ICX**. It's a robust, feature-rich, flexible, reliable phone system that can grow with the company it serves. At the best price/performance combination available.

Here's just a few of the cutting-edge features of this new Key/PBX system:

q Supports a larger phone base.

The ICX is expandable from 96 ports (per cabinet) up to 576 ports (6 cabinets total). The maximum port configuration for each cabinet can range from 0 trunks + 96 extensions, to 88 trunks + 8 extensions.

q Simple cabinet structure.

The two types of cabinets - base and expansion - have exactly the same card slot structure, so there's no confusion where to install cards. Many of the parts in these two cabinets are also the same.

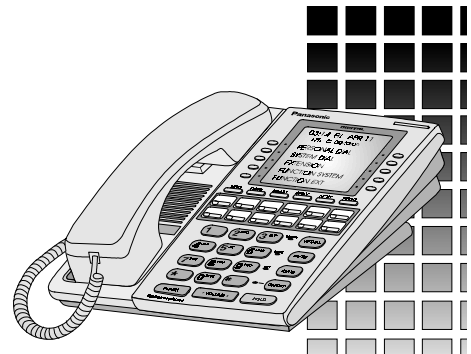

q **Universal ports.**

The ICX offers flexible slot configuration. You can mount Trunk or Extension Cards in any of the 12 Free Slots in the cabinet. (CPC cards and option cards have their own designated slots.) Trunk and Extension Cards are not limited to a particular slot assignment; you mount them where you want them. Then tell the system (in programming) how each slot is configured. You control the system; the system doesn't control you.

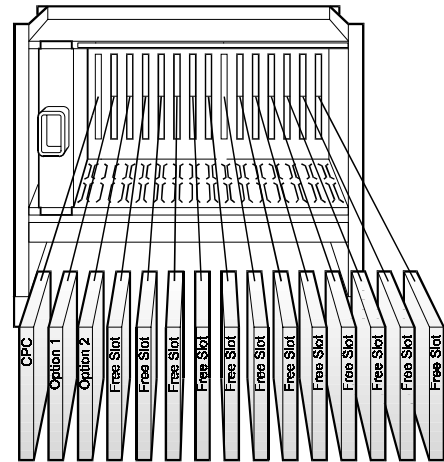

q **Seamless expansion capabilities.**

You can start with one cabinet, then pile on more cabinets later. The expansion will be transparent to end-users -- except they will suddenly be able to plug in more phones. You don't have to re-program the entire system when you add on (just the new additions). Nor do you have to use another type of phone.

q **Flash memory upgrades.**

No more chip change-outs. No more complicated hookups. No more waiting forever to download/upload from the phone system. To upgrade your ICX system, use what's called a PCMCIA card. It looks like a credit card. Take it to the phone system site, and plug it into the CPC card. Upgrade the system with a few simple programming steps. Then, either remove the card (for a CPC-96 or CPC-288 configuration) or leave it plugged in (for a CPC-576). That's it.

q **Existing DBS phones will work with the ICX.**

If you already have a DBS system, you don't have to buy new phones for the ICX (unless you need more). It'll work with the phones you already have.

q **Existing A series/VB-9 phones will work with ICX. (Future Feature)**

If you already have a A series or VB-9 system, you can connect those phones to ICX. Although there is some limitation on featurewise.

q **New "Voice Recognition" phones available.**

With these new phones and ICX technology, users can literally *tell* their phones what to do. Instead of dialing your home phone number, for example, press the Voice Recognition key and say, "Home." The phone will automatically call your house.

q **Dynamic Bandwidth Allocation for digital signaling.**

The ICX provides the ability to split up a single bandwidth, and allocate it to several different sources. The allocation is achieved via hardware installations of special ISDN adapters. This powerful technology can be used to conduct advanced applications from one phone outlet, such as video-conferencing, data transmission, multiple phones, voice, etc.

q **Computer Telephony interface capability. (Future Feature)**

We've developed proprietary software for several Computer Telephony applications, in which the desktop phone and the PC computer merge together into a single entity. The merger works like this: Install a special board inside the computer. Install our proprietary software in Windows. Plug the phone's handset into the board. Plug the board into the phone jack. Presto! you now have a computer phone that can be used to click-and-drag call transfers, monitor extension status, generate call traffic reports, etc.

Panasonic offers two **PC Console applications for the Attendant position**. One is a low-end product (supports up to 96 extensions) and the other is high-end (up to 384 extensions). The PC Console controls the system's calls from the computer; the attendant can watch everything on the

- r PC monitor.

Panasonic also offers proprietary software for a **PC Phone**, which replaces the desktop extension phone. End-users can control their own phone calls using the computer.

- r **Automatic Call Distribution is built-in.** You don't have to go to a third-party provider to get ACD. With the ICX's proprietary ACD option, calls can be automatically distributed to the least-busy extension first, or on a next-available-extension basis. If the extension doesn't answer the call, you can program the system to continue searching, transfer to a particular extension, transfer to Voice Mail, or disconnect the call. You can control what the caller hears while he/she is waiting. Supervisors can instantly access the current status of all agents right from their desk using a Large-Display telephone - no need for costly computer programs to provide "real-time reporting." MIS reports can also be generated.
- r **2-Way Call Recording is available.** It's in the ICX's Built-In Voice Mail option. Users can record phone conversations, and store them (like messages from callers) in mailboxes.

SYSTEM TECHNOLOGY

The ICX is a completely digital system. Information is exchanged between the major system components using Pulse Code Modulation (PCM). The conversation exchange between digital telephones is also digital, converting the digital information to analog just before it reaches your handset or speaker.

Stored Program Control (SPC) is accomplished via a 16-bit processor (for CPC-96 and CPC-288 configurations) or 32-bit processor (for CPC-576). This technology controls the powerful system features of the ICX. Each processor's customized memory (program settings) is backed up by an on-board, 6-year lithium battery which is field-replaceable.

The system provides maximum protection from outside power surges with built-in triple surge protection for CO outside line connectors.

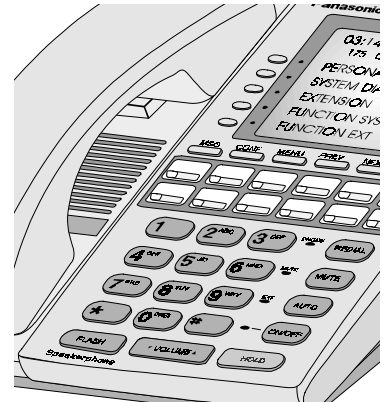

POWER REQUIREMENTS

The system must be connected to an input power source of 100~240V AC (+/-10%), 60 Hz. Each cabinet's power supply automatically generates 5V DC and 24V DC necessary to power the various printed circuit boards for station and peripheral equipment. Optional backup batteries are available, and are designed to safely fit into the cabinet. The power supply contains a charger that maintains a full charge to the backup batteries, which have a 3-year life and can support the phone system for up to 30 minutes at a time.

DIAGNOSTIC MAINTENANCE

The printed circuit board (PCB) cards are designed to slide easily into slots within the ICX cabinet. By using diagnostic troubleshooting, small problems can be isolated to specific cards. Some cards are designed to be installed and extracted from slots without turning off the power, allowing system maintenance to be completed without interrupting the entire system.

For example, say you're having a problem with one of the trunks on a Loop Start Trunk Card. Instead of having to turn off the power, or reprogram anything, or alert anyone get off the phone, all you have to do is throw a Maintenance switch on the Card. This will busy-out the trunks on that Card that aren't being used at the moment, but will leave the trunks in use alone, allowing people to finish their phone calls without any disruption. The LEDs on the Card will tell you when the trunks become vacant. When all LEDs are extinguished, the Card can be replaced.

PROGRAMMING THE PHONE SYSTEM

System programming can be accomplished in several ways without disrupting the system. Most programming changes take place as you are programming, what we refer to as "live" programming.

q **Programming from a display telephone.**

Programming can be performed on any small-display or large-display extension phone. A large-display phone is recommended because its LCD buttons can perform special one-touch functions in programming (such as "stepping" through addresses, entering a pause in a speed-dial number, etc.). The user must enter a valid password to enter programming mode.

q **Programming from the RS232 port.**

A PC computer or laptop can be connected to the ICX phone system, via a DB9-pin RS232 port on the SCC card inside the cabinet. Then, from the computer, you can program the phone system with our proprietary PC-based software, **PC Customize Tool**.

q **Programming from a remote location.**

Again using PC Customize Tool, the ICX can be programmed from a remote location, using an offsite computer terminal to call into the phone system.

*Take advantage of our **PC Customize Tool**, a software package designed to maintain your ICX program settings on a computer. With this Windows-based software, you can backup and restore phone system databases, as well as perform "live" programming and maintenance.*

SUPPORTING DOCUMENTATION

Panasonic provides extensive documentation for the ICX, including the following manuals.

Section 300 - Installation

This manual provides hardware installation instructions for the main components of the ICX. (Additional reference manuals, listed below, may be required for optional equipment.)

Section 400 - Programming

This manual is a general reference for programming the ICX using a display phone. The manual is organized to match the programming configuration.

Section 450 - Programming Forms and Tables

This manual contains forms that are designed to assist you in planning and implementing a ICX phone system. Typical users of this manual are Customer Service representatives and Installers.

Section 510 - Built-In Voice Mail Reference

This manual provides complete instructions on installing and programming the optional Built-In Voice Mail package, which provides simplified Voice Mail/Auto Attendant functionality, along with 2-way call recording capability.

Section 520 - Built-In ACD Reference

This manual provides complete instructions on installing and programming the optional Built-In ACD (Automatic Call Distribution) package, which provides simple ACD functionality.

Section 530 - PC Attendant Console Reference

This manual provides installation and operating instructions for the PC Attendant Console, a computer telephony product that merges the computer and a DSS/72 together into a single entity.

Section 550 - ISDN Reference

This manual contains installation and programming instructions for the various aspects of ISDN options, including T-point/S-point PRI and BRI.

Section 700 - Feature Operation

This is a general operating reference guide for the ICX. It describes system and telephone features. It is designed for use by both the dealer and the end-user.

Section 720 - SLT Phone Quick-Reference

This is a quick-reference guide for Analog devices such as the SLT phone. It covers only the most commonly-used features, and is intended for the end-user.

Section 751 - Digital Key Phone/DSLTL Quick-Reference

This is a quick-reference guide for Digital Key Telephones and DSLTLs (Digital Single-Line Telephones). It covers only the most commonly-used features, and is intended for the end-user.

Section 770 - Voice Recognition Telephone Adapter User Guide

This is a user guide describing the additional features of the Voice Recognition Telephone. It is intended for the end-user.



Integrated Communication eXchange

**The products you need. The services you deserve.
From the name you trust.**

CHAPTER 2 - SYSTEM HARDWARE

OVERVIEW

This section describes the purpose and functionality of the main components of the system. By understanding how these components work, you can easily configure a system that meets your specific needs.

This section is divided into the following categories:

Cabinets

The ICX cabinets are explained in detail below. Both the base cabinet and the expansion cabinet share the same PCB cards. Both cabinets can attach to any of the proprietary telephone sets offered by Panasonic. Each cabinet includes its own power supply, and is designed with dedicated slots for CPC and option cards, and free slots for trunk, extension, and built-in option cards.

Common Cards

The common cards control the signalling and features used by all other cards in the system. Without common cards, other cards cannot function. The common card which is considered the "brains of the system" is called the Central Processor Card, or CPC. Each phone system requires a processor to operate. With the exception of a few distinct features which are clearly defined in Chapters 3 (System Features) and 4 (Station Features) of this document, the software for all processors function the same way.

Telephone Company Interface Equipment

Panasonic offers a wide variety of interface circuits which allow the ICX to attach to Central Office (CO) and/or common carrier equipment. This interface equipment is explained here in Chapter 2.

Station Interface Equipment

The ICX allows for connection of Panasonic proprietary telephones as well as various analog telephones and devices provided by other manufacturers. This chapter includes descriptions of the cards and equipment needed to accomplish these connections.

Optional and Miscellaneous Equipment

The cards and interfaces that provide optional services, and all miscellaneous equipment, are explained in this chapter.

Station Equipment

All Panasonic proprietary stations are explained in this chapter.

System Hardware Connections

Shown on the next page is an illustration of ICX trunk and extension line connections, as well as some of the more popular peripheral connections.

System Connections (trunks, extensions, peripheral equipment)

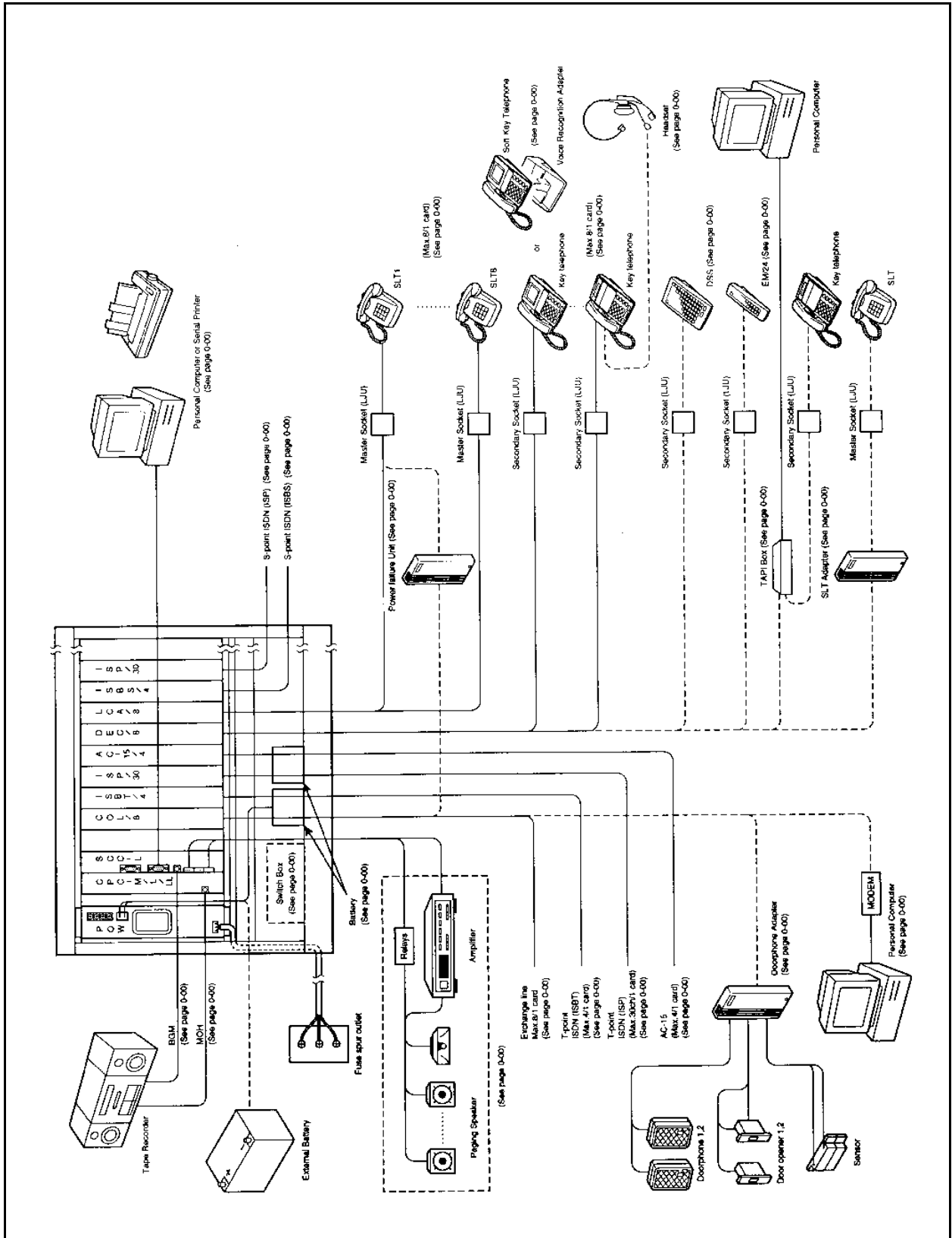

CABINETS

CAB-40 Base Cabinet (VB-44010)

Each CAB-40 Base cabinet supports up to 40 ports using flexible or universal card slots. Dual system connection (CAB-40 + CAB 40) is available using connection cable kit.

Multiple slot types are used in the CAB-40 Base cabinet. These slot types are as follows:

Slot type	# of slots	Unit type to be installed
Power slot	1	Accommodates the cabinet power supply. The power supply comes installed in the cabinet.
CPC slot	1	CPC in first Base cabinet (CPC-96);
Flexible slots	5	Accommodates trunk cards, extension cards, other cards (such as MFR), etc.
Option slots	2	The option slots support common control cards (such as MFR, SCC, and TSW).

Optional backup batteries can be installed for system operation in the event of a power failure.

CAB-90 Base/Expansion Cabinet

Two types of cabinets are used in the ICX:

- 1) the CAB-96 **Base cabinet** (VB-44020)
- 2) the CAB-96B **Expansion cabinet** (VB-44021).

Each cabinet provides 96 universal ports. Systems can be configured with one to six cabinets in a "building-block" fashion. The bottom cabinet in a column is the **Base** cabinet. The middle and top cabinets in a column must be **Expansion** cabinets.

The maximum configuration for a fully expanded (6-cabinet) system supports a maximum of 576 ports, and contains two Base cabinets and four Expansion cabinets (see figure below).

Maximum 6-Cabinet Configuration

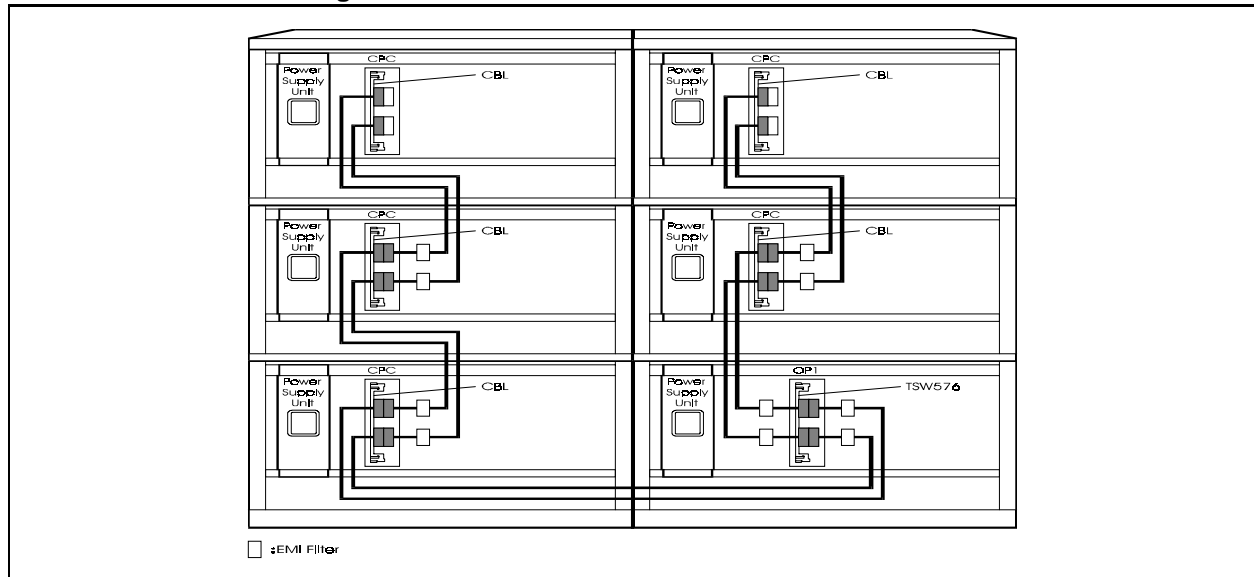

CAB-96 Base Cabinet (VB-44020)

Each CAB-96 Base cabinet supports up to 96 ports using flexible or universal card slots. Up to two CAB-96 Base cabinets can be installed in a system.

Multiple slot types are used in the CAB-96 Base cabinet. These slot types are as follows:

Slot type	# of slots	Unit type to be installed
Power slot	1	Accommodates the cabinet power supply. The power supply comes installed in the cabinet.
CPC slot	1	CPC in first Base cabinet (can be either CPC-96, CPC-288, or CPC-576); CBL (expansion interconnection card) in second Base cabinet.
Flexible slots	12	Accommodates trunk cards, extension cards, other cards (such as MFR), etc.
Option slots	2	The option slots support common control cards (such as MFR, SCC, and TSW).

Optional backup batteries can be installed for system operation in the event of a power failure.

The CAB-96 Base Cabinet

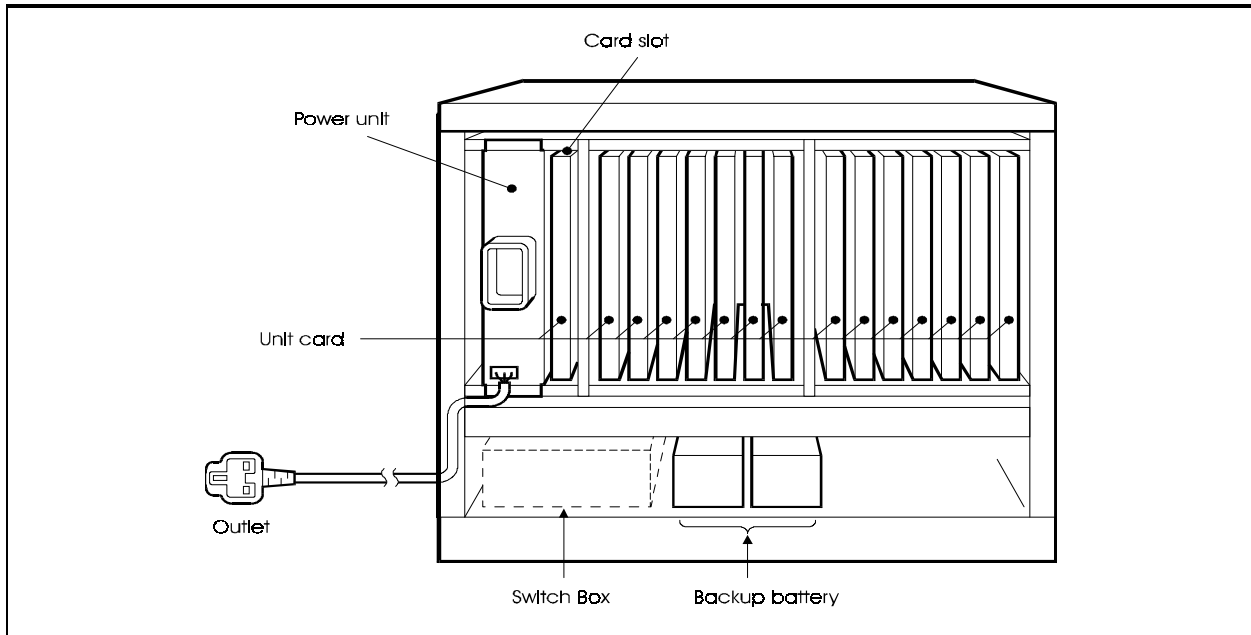

CAB-96B Expansion Cabinet (VB-44021)

Each added CAB-96B Expansion cabinet expands the system capability by an additional 96 ports. One or two CAB-96B Expansion cabinets can be installed on top of a CAB-96 Base cabinet. Up to four CAB-96B's can be installed in a fully equipped, 6-cabinet system.

Multiple slot types are used in the CAB-96B Expansion cabinet. These slot types are as follows:

Slot type	# of slots	Unit type to be installed
Power slot	1	Accommodates the cabinet power supply. The power supply comes installed in the cabinet.
CPC slot	1	Accommodates the CBL (expansion interconnection) card.
Flexible slots	12	Accommodates trunk cards, extension cards, and other cards (such as MFR).
Option slots	2	The option slots support common control cards (such as MFR and SCC).

Optional back-up batteries can be installed for system operation in the event of a power failure.

Fittings for Building Block Connection (VB-44024)

These fittings are for interconnecting cabinets in the building-block configuration. The fittings are normally shipped with the Expansion cabinets.

Battery Backup (VB-44025)

The backup batteries supply power to the system in the event of a power failure. If the Battery Backup option is chosen for the system, each cabinet requires its own set of batteries (1 kit per cabinet, 2 batteries per kit). The batteries can back up the system for up to 30 minutes.

Switch Box (VB-44023)

The Switch Box installs in the Base cabinet, and controls power for the Base cabinet and the Expansion cabinet(s) installed above it. When the power supply is turned on or off in the Base cabinet, power is also turned on or off for the Expansion cabinet(s).

CONTROL UNIT

CPC-96 (VB-44410)

The CPC-96 supports a single cabinet (40/ 96ports) and utilizes a 16-bit Central Processor Unit (CPU).

Included are the time switch (4HW X 4HW), 4 MFR circuits (DTMF receivers), 8 pairs of conference circuit (3 Member), service tones, DTMF generators, an input terminal for external holding tone source (RCA jack), connecting terminals for network synchronous package, I/F connector for an external PC card and a built-in modem (300 bps).

Since the time switch is built into the CPC-96 card, a separate time switch card is not required.

CPC-288 (VB-444201)

The CPC-288 supports up to three cabinets (288 ports) and utilizes a 16-bit CPU.

Included are 4 MFR circuits (DTMF receivers), an input terminal for external hold tone source (RCA jack), I/F connector for an external PC card and a built-in modem (300bps).

The CPC-288 requires the TSW-288 Time Switch Card.

CPC-576 (VB-444301)

This unit supports up to six cabinets (576 ports) and utilizes a 32-bit CPU.

It provides 4 circuits MFR (DTMF receivers), an input terminal for external hold tone source (RCA jack), an I/F connector for a customized PCMCIA memory card, and a built-in modem (300bps).

The CPC-576 requires the TSW-576 Time Switch Card.

Program downloads are performed to the internal memory of the system through the attached customized PCMCIA card. The PCMCIA card is necessary during normal operating time and cannot be removed during normal operation.

Time Switch - TSW-288 (VB-444202)

The TSW-288 provides the time switch circuitry required for up to 288 ports. This card must be used with the CPC-288. This unit installs in the first option slot of the first Base cabinet. Only one card can be installed in a system.

The TSW-288 provides the time switch (14HWx14HW), service tones, DTMF generator, connecting terminals for network synchronizing unit interface, and 8 pairs of 3-party conference circuits.

Time Switch - TSW-576 (VB-444302)





The TSW-576 provides the time switch circuitry required for up to 576 ports. This card must be used with the CPC-576. This card installs in the first option slot of the first Base cabinet. Only one card can be installed in a system.

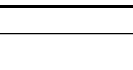

The TSW-576 provides the time switch (24HWx24HW), service tones, DTMF generator, connecting terminals for network synchronizing unit interface, and 8 pairs of 3-party conference circuits.

Connection Cable Kit - CBL Kit (VB-44450)

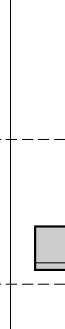
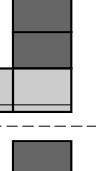
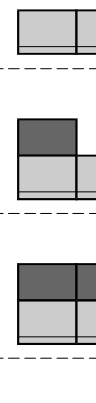
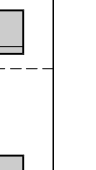
This card supports the interconnection between CAB40 and CAB40. Two connection cable cords, one for master cabinet, the other for slave cabinet and cables are packed.

Connecting CAB40 Dual system

Ports	Method of System Expansion		
	Single System	Dual System	Building Blocks
40		—	—
72	—		—
96		—	—
192	—	—	
288	—	—	
384	—	—	
480	—	—	
576	—	—	

CAB40 : 
 CAB96 : 
 CAB96B (Expand Cabinet) : 

Building Block Expansion Cable Kit - CBL (VB-44451)

This card supports the interconnection between cabinets when multiple cabinets are used. This card establishes the connection between PCM-HW bus and terminal control bus of the Base cabinet and additional cabinets, as well as the connection to the time switch unit (TSW-288/TSW-576) in the first Base cabinet.

Each cabinet after the first cabinet requires a CBL kit. The supplied card must be installed in the CPC slots of all but the first cabinet. The supplied inter-cabinet connection cable is used with each added cabinet.

ICX to DBS Expansion Cable Kit - CBLDBS (VB-44452)

The CBLDBS card supports the interconnection between cabinets when DBS cabinets are connected to the ICX. This card establishes the connection of the PCM-HW bus and terminal control bus between the base ICX cabinet and the DBS cabinet(s), and also the connection to the time switch unit (TSW-288/TSW-576) installed in the first Base cabinet.

NOTE: The ICX-to-DBS configuration can support a maximum of 528 ports, including the ports in the DBS cabinet. A maximum of two DBS cabinets can be included in the configuration. DBS DEC (Digital Extension Cards) are supported, but there is no DBS TRK (trunk) card support. A special MDF board is required; it is included with the CBLDBS kit.

The CBLDBS card installs in the AUX1 slot of each connected DBS cabinet. An inter-cabinet connection cable is used with each cabinet.

Connecting the ICX to a DBS system

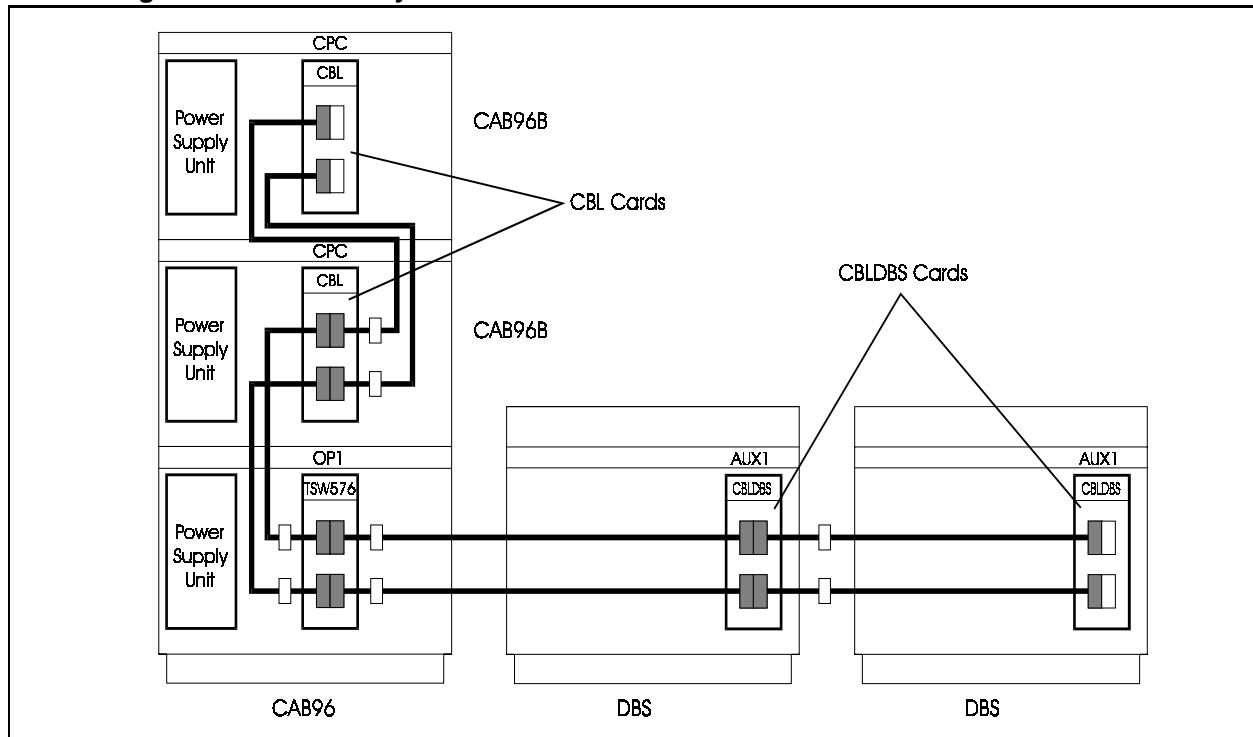

Network Synchronizing Unit - SYNC (VB-44460)

This unit provides network synchronization and is required with digital circuits such as ISDN. The SYNC card synchronizes the PCM clock with an outside resource. When digital circuits are used, one SYNC card is required and installs on the CPC-96, TSW-288, or TSW-576 card.

TRUNK LINE CARDS

Loop Start Card - LS (VB-44510)

The Loop Start Card supports up to 8 loop start CO lines and can be installed in any flexible slot. This card provides lightning arresters and UL1459 safety circuitry, and can be directly connected to CO lines.

Caller-ID Unit (CID)(VB-44513)

This card supports Caller ID on loop start trunks. This unit installs directly on top of the Loop Start Trunk Card(VB-44510), and supports all 8 of that Card's circuits for Caller ID.

Primary Rate Interface Card (T-point) - PRI (VB-44540)

T-point primary rate interface requires a DSU for connection to the carrier circuit. A Network Sync card is also required.

A lightning arrester is built into the PRI card.

Basic Rate Interface Card (T-point) - BRI (VB-44530)

This supports T-point Integrated Services Digital Network (ISDN) Basic Rate Interface (BRI) (2B+D:144 or 192kbps). This card can be installed in any flexible slot.

The functions supported are as follows:

- q **Dial Type** Enblock setting and enblock setting at the sub-address.
- q **Information transferring capability** (speech and data) at the CO trunk.

The BRI T-Point connects through a DSU to the T-point ISDN Basic Rate Interface.

A lightning arrester is built into the BRI card.

This supports T-point Integrated Services Digital Network (ISDN) Primary Rate Interface (PRI) (23B+D/24B:1544kbps) (30B+D/31B:1984kbps) and also S-point ISDN Primary Rate Interface.

The PRI card can be set to support either 8, 16, 23/24 or 30 channels. When the card is set for 16 channels, the card logically occupies 2 flexible card slots. When the card is set for 23/24 or 30 channels, the card logically occupies 3 or 4 flexible card slots.

Unlike other most other cards, due to the interaction between card slots, the PRI card must be installed in selected flexible card slots. Up to 3 PRI cards can be installed in a single cabinet. A fully configured 6-cabinet system can support up to 18 PRI cards.

E&M Trunk Card - E&M (VB-44560)

This card supports E&M type private line interface (Speech pass 4W/2W, Control line 4W). The signaling methods that are supported include Immediate and Wink methods.

When installed in any flexible slot, the E&M Trunk Card supports call signal detection and answer from other PBX or carrier equipment, calling to the E&M private line, dial sending and speech.

Each E&M card includes 4 circuits.

An internal -48V Power Supply (VB-44022) must be installed in the same cabinet with the E&M Trunk Card.

The E&M interface can connect to another PBX with E&M capability. However, this unit does not support connection to an E&M that provides only Type 1.

This unit contains a built-in lightning arrester; however, external safety devices (available from standard telecommunications suppliers) are required when installing outside the building.

DID Trunk Card - DID (VB-44520)

This card supports 8 DID incoming CO lines using Immediate and Wink signaling methods. The DID can be either Dial Pulse (10PPS) or DTMF (only for Wink). MFR circuits are used when the Wink method is selected.

An internal -48V Power Supply (VB-44022) must be installed in the same cabinet with the E&M Trunk Card.

A lightning arrester is built into the DID TRK card.

T1 Trunk Card - T1 (VB-44550)

The T1 interface is a digital CO line card that provides up to 24 voice channels over a four-wire circuit.

The T1 card can be set to support either 8, 16, or 24 channels. When the card is set for 16 channels, the card logically occupies 2 flexible card slots. When the card is set for 24 channels, the card logically occupies 3 flexible card slots.

Unlike most other cards, due to the interaction between card slots, the T1 card must be installed in selected flexible card slots. Up to 3 T1 cards can be installed in a single cabinet. A fully configured 6-cabinet system can support up to 18 T1 cards.

The T1 interface requires a CSU for connection to the carrier circuit. A Network Sync card is also required.

A lightning arrester is built into the T1 card.

EXTENSION CARDS

Digital Extension Card - DEC (VB-44610)

This card provides 8 digital circuits. Each circuit supports the Panasonic Digital Key Telephone, Digital Single Line Telephone, DSS/72, and EM/24. Supply voltage for the telephones is supplied by the digital circuits.

This card can be installed in any flexible slot.

Analog Extension Unit (VB-44520)

This card provides 8 analog circuits. Each circuit supports standard analog telephone devices such as analog telephones, answering machines, fax machines, modems, cordless telephones, etc. The connected device(s) can be either pulse dial (rotary) or DTMF. Ringer circuitry is built into the card.

A lightning arrester is built into the analog circuits.

BRI Unit (S-point) (VB-44630)

This unit supports Basic Rate Interface (2B+D:144 or 192kbps) for S-point ISDN. Each card provides 4 BRI circuits.

This card can be installed in any flexible slot.

The system supplies +40V to the ISDN terminal which is connected to S-point interface card.

A lightning arrester is built into the BRI circuits.

Primary Rate Interface Card (S-point)-PRI (VB-44540)

Same card as T-point.

OPTIONS

MFR Card (VB-44110)

The Multi-Frequency Receiver (MFR) card accepts dialled DTMF tones and determines the dialled digits. Each card contains 8 receiver circuits.

This card can be installed in either an option slot or any flexible slot. A maximum of one card can be installed in a cabinet, with up to 6 cards in a fully configured system.

8-Party Conference Card (VB-44120)

This card provides a set of 8-party conference circuit. (These are in addition to the 3-party conference circuits built into the CPC-96, TSW-288 and TSW-576.)

This card is installed in a flexible slot. A maximum of one card can be installed in a cabinet, with up to 6 cards in a fully configured system.

Built-In ACD Card (VB-44140)

This card, combined with the Voice Processor Unit card (4 circuits) (VB-44160), provides simplified Automatic Call Distribution functions. MIS (Management Information System) reports can be output from the RS232C port of the ACD card. The reports can be printed out by connecting a printer to the RS232C port. However, a PC and printer cannot be simultaneously connected to the RS232C (the RS232C cable must be used exclusively for one connection).

Only one Built-In ACD can be installed in a cabinet. A maximum of two Built-In ACDs can be installed in a system.

Built-In Voice Mail and Built-In ACD cannot be installed in the same cabinet, since they use the same flexible slots.

Built-In Voice Mail Voice Storage Card (VB-44170)

This is one of two cards required for Built-In Voice Mail. One or two Voice Processing Cards (VB-44160 for 4 circuits; or VB-44150 for 8 circuits) are also required for Built-In Voice Mail.

The Voice Mail Voice Storage Card provides most of the functions of Built-In Voice Mail, including hard disk storage of the voice data.

Only one Built-In Voice Mail can be installed in a single cabinet. A maximum of four Built-In Voice Mails can be installed in a fully configured system.

Don't install the Voice Mail Unit from the top cabinet, otherwise the unit will be damaged by heat.

Built-In Voice Mail and Built-In ACD cannot be installed in the same cabinet, since they use the same flexible slots.

Voice Processing Card (4 circuits) (VB-44160)

Two sizes of voice processing cards are available for use with the ICX. The VB-44160 voice processing card contains four voice processing circuits and can be used with Built-In Voice Mail and Built-In ACD. The other voice processing card, the VB-44150 Voice Processing Card, contains eight voice processing circuits and can only be used with Built-In Voice Mail. One or two voice processing cards (any combination of types) are required for Built-In Voice Mail. One VB-44160 four-port Voice Processing Card is required for ACD.

Only one Built-In Voice Mail can be installed in a single cabinet. A maximum of four Built-In Voice Mails can be installed in a system. Built-In Voice Mail and Built-In ACD cannot be installed in the same cabinet, since they use the same flexible slots.

Voice Processing Card (8 circuits) (VB-44150)

Two sizes of voice processing cards are available for use with the ICX. The VB-44150 Voice Processing Card contains eight voice processing circuits and can only be used with Built-In Voice Mail. The VB-44160 voice processing card contains four voice processing circuits and can be used with Built-In Voice Mail and Built-In ACD. One or two voice processing cards (any combination of types) are required for Built-In Voice Mail.

Only one Built-In Voice Mail can be installed in a single cabinet. A maximum of four Built-In Voice Mails can be installed in a system. Built-In Voice Mail and Built-In ACD cannot be installed in the same cabinet, since they use the same flexible slots.

SCC Unit (VB-44181)

The Service Circuit Card provides enhanced service functions such as two RS232C ports (9600bps), a Background Music input, and the external paging control.

Only one Service Circuit Card can be installed in a system.

RS232C port:	2 ports (maximum 9600bps)
BGM input terminal:	1 port (with RCA jack)
On/Off control of the external amplifier:	One contact
Number of contacts for on/off control of external equipment:	5 contacts
Maximum current of control board:	.25mA (total charge)

Power Failure Transfer Unit (VB-43703)

The four-line power failure transfer is designed to switch outside dial tone from the telephone company direct to a single line telephone when power is lost. The power failure transfer unit connects four SLTs to four CO lines.

1 Line SLT Adaptor (VB-44100)

By connecting the 1 line SLT Adaptor to the DEC/8 card, you can connect an SLT instead of an extension keyphone. One SLT can be connected to one 1 line SLT Adaptor unit.

STATION EQUIPMENT

Overview

The full line of Panasonic ICX phone systems offer a wide variety of critically acclaimed telephones. All telephones work with all models of ICX systems.

As the user interface, the station instrument is a crucial element of the communications system. All ICX telephones are designed to provide easy access to system features and functions. A mixture of fixed and programmable feature keys allow the station to be specifically customized to accommodate the needs of each user. A wide variety of telephones are offered with different combinations of programmable keys, speakerphones, and liquid crystal displays to provide a complete solution to any telecommunication requirement. The advanced economic design and quality manufacturing assure longevity of the ICX system and stations, protecting the investment of the end-user.

All telephones are designed with the following features:

- q Key lettering is a part of the key mold, making it impossible for lettering to fade or rub off.
- q Special film coating enables displays to be seen under extremely bright lighting conditions.
- q Adjustable display contrast levels adapt to different lighting conditions.
- q Adjustable base for 3 different LCD viewing positions.
- q Photo optic controlled hookswitch, which extends the life of the hookswitch.
- q Unique one-board design that allows for a more compact, durable product.
- q Special material separating the keys from the PCB reduces damage from liquid spills.
- q Built-in processors provide automatic identification when plugged in at any digital port, assuring instant operation.
- q Above-standard cords contain clamps to attach to the telephone's base, alleviating stress on modular connectors.
- q Hearing-aide compatible.
- q Headset compatible.
- q Built-in wall mounting capability in the base of the telephone.
- q Textured finish on selected high-contact areas reduces scratching and fingerprinting.
- q Moulded with an extremely durable, high-impact polymaterial for break resistance.

- q Telephone handsets allow easy installation of handset cord swivels.

Model Options

Panasonic offers a wide variety of options for telephones so that you can select the one that is just right for you. All display phones come with a built-in speaker phone. Hands-Free Answerback (HFAB, described in detail in Chapter 4 - Station Features) is standard on all phones except the Digital Single Line. Flexible Function (FF) keys containing dual-coloured LEDs are user programmable to access outside lines or execute system and station features. Listed below are some of the options available with the different models:

- 12 key-Speakerphone VB-44221
- 12 key-Display Speakerphone VB-44223
- 12 key-Large Display Speakerphone VB-44225
- 12 key-Soft key Display Speakerphone VB-44224
- 24 key-Display Speakerphone VB-44233
- EM24-24 key Expansion Module VB-44310
- DSS-72 Key DSS/BLF VB-44320
- Digital Single Line telephone VB-41200

UK, HK,
Indonesia,
Malaysia:

In addition to the above digital telephone module, the System supports the complete of the DBS proprietary VB-3411/3611 series telephones and VB-3011 Digital SLT.

Taiwan:

The former DBS proprietary telephone are not available to connect to ICX systems without modification. Please consult to your order.

MODEL DESCRIPTIONS

Digital Single Line Telephone (VB-41200)

Provides single line service on a digital telephone. Buttons include hold, on/off, Memory, redial, RECALL/FLASH and conference. Large message waiting light. Slide controls for volume adjustment. Does not support handsfree answerback on intercom. Requires one digital port.

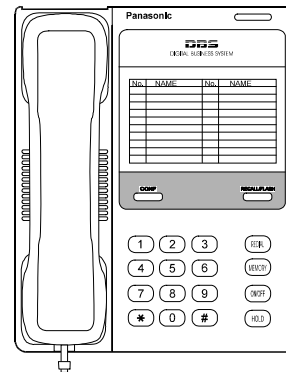

12 Key Speakerphone (VB-44221)

Provides 12 flexible feature/line keys (dual coloured LED) and 10 personal speed dial keys. Supports handsfree speakerphone, off hook voice announce, and headsets. Requires one digital port. Wall-mountable.

12 Key Display Speakerphone (VB-44223)

Provides 12 flexible feature/line keys (dual coloured LED) and 10 personal speed dial keys with an integrated handsfree speakerphone and 2 line liquid crystal display(LCD). 4 programmable soft keys are included with the display to provide access to advanced system features. Supports handsfree answerback on intercom, off hook voice announce, and headsets. Requires one digital port. Wall-mountable.

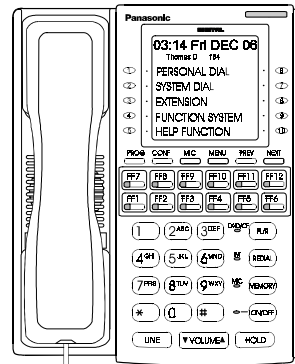

12 Key Display Speakerphone with Voice Response - (VB-44224)

Provides 12 flexible feature/line keys (dual coloured LED) and 10 personal speed dial keys with an integrated handsfree speakerphone and 2 line liquid crystal display(LCD). 4 programmable softkeys are included with the display to provide access to advanced system features. Supports handsfree answerback on intercom, off hook voice announce, and headsets. Requires one digital port. Wall-mountable. Internal circuitry for Voice Recognition feature.

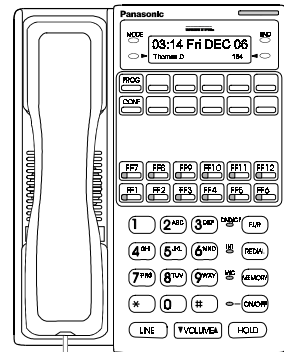

12 Key Large Screen Display Speakerphone- (VB-44225)

Provides 12 flexible feature/line keys (dual coloured LED) with a 7 line Liquid Crystal interactive display. The top line of the display contains 15 characters. The remaining 6 contain 16 characters per line. There are 10 softkeys to interact with the large screen display. User definable screens can be assigned to provide ultimate user-friendly flexibility. This telephone comes equipped with a built-in speakerphone for handsfree conversation on outside line calls and a handsfree answerback circuit for responding to intercom calls. This telephone also supports off hook voice announce and headsets. Requires one digital port. This telephone is wall-mountable.

24 Key Display Speakerphone (VB-44233)

Provides 24 flexible feature/line keys (dual coloured LED) and 10 personal speed dial keys with an integrated handsfree speakerphone and 2 line liquid crystal display(LCD). Supports handsfree answerback on intercom, off hook voice announce, and headsets. Requires one digital port. Wall-mountable.

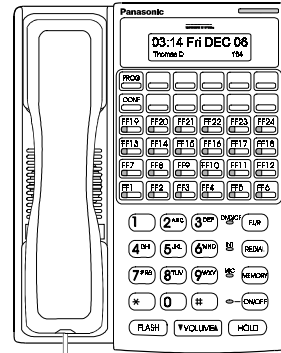

24 Key Expansion Module (VB-44310)

Provides 24 flexible feature/line/Direct Station Selection (DSS)/Busy Lamp Field (BLF) keys (dual coloured LED). This unit is used in conjunction with a digital station. Comes equipped with a joining bracket to connect it to the telephone to give the appearance of one complete unit. Requires one digital port. Wall-mountable. Includes elevation supports.

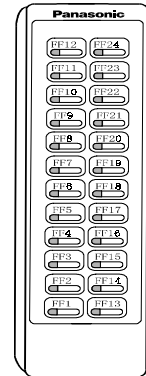

72 Button DSS/BLF (VB-44320)

Provides 72 flexible feature/line/Direct Station Selection (DSS) Busy Lamp Field (BLF) keys (dual coloured LED). Normally used in conjunction with attendant console positions, but can be used for any extension port. Comes equipped with a joining bracket to connect it to the attendant telephone to give the appearance of one complete unit. Requires one digital port. Wall-mountable. Includes elevation supports.

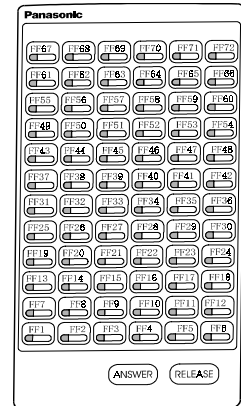

OPTIONAL TERMINAL DEVICES

Voice Recognition Unit Adapter (VB-44101)

Working in conjunction with the 12 key Display Speakerphone with Voice Response Telephone (VB-44224), this adapter adds voice response functions to the telephone. The user can program the telephone to automatically dial numbers based on the user's voice commands.

PC Phone (VB-44332) (Future Feature)

The PC Phone is designed to replace an extension phone, adding telephony capability to a desktop PC. It is comprised of a PC card installed inside the computer; application software; and various connections to the computer (e.g., handset, headset, etc.). The PC Phone then plugs into a ICX extension port, and becomes a sophisticated "on-screen" phone for the end-user. For more information, see Chapter 5 - Special Applications.

PC Attendant Console/96 (VB-44330) (Future Feature)

This is one of two PC Attendant Consoles offered by Panasonic; both consoles are designed to replace an Attendant phone and add telephony capability to a desktop PC. The PC Attendant Console/96 is a 2-port solution that is equivalent to one key phone (either a 24-key small-display phone, or a 12-key large-display phone) with one DSS/72; it can monitor up to 96 extension ports. For more information, see Chapter 5 - Special Applications.

PC Attendant Console/384 (VB-44331) (Future Feature)

This is one of two PC Attendant Consoles offered by Panasonic; both consoles are designed to replace an Attendant phone and add telephony capability to a desktop PC. The PC Attendant Console/384 is a 6-port solution that is equivalent to one key phone (either a 24-key small-display phone, or a 12-key large-display phone) with five DSS/72 consoles; it can monitor up to 384 extension ports. For more information, see Chapter 5 - Special Applications.

TELEPHONE KEY LAYOUT

12-Key Small-Display Telephone key layout

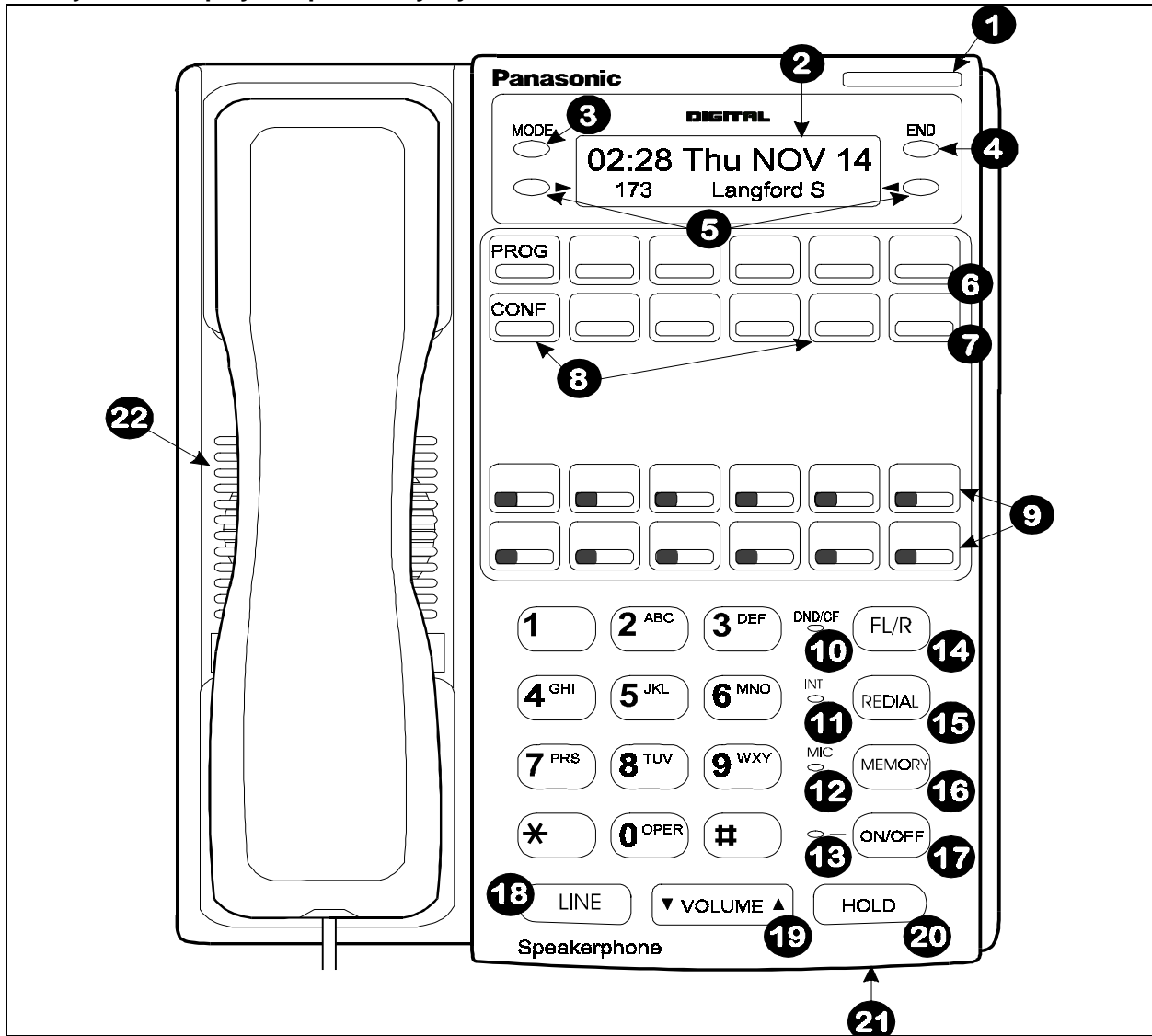

Small-Display Telephone Features

No.	Feature	Description
1	Message Waiting Indicator	Indicates that you have a message.
2	Display	Displays information about the phone's status, menus, and dialling directories.
3	MODE Key	Used to change display modes from Default Mode to Speed Dial Mode or Extension Directory Mode.
4	END Key	Used to exit Directory Mode and return the display to Default Mode.
5	Soft Keys	Used to select speed dial directories, or extension numbers.

No.	Feature	Description
6	PROG Key	Used to program Flexible Function (FF) and one-touch keys, to adjust ringer volume, and to send a flash signal. Depending on the setup of your system, may also be used to transfer calls.
7	CONF Key	Used to establish conference calls and to check FF key and one-touch features.
8	One-Touch Keys	Used to make outside calls or to access system features.
9	Flexible Function (FF) Keys	Used to access outside lines or to access system features.
10	DND/CF Indicator	Indicates that Do-Not-Disturb (DND) or Call Forwarding is set.
11	EXT Indicator	Lights when you are on a call and flashes when you hold a call.
12	MIC Indicator	Indicates that your microphone is activated. Lights solid when your hands-free microphone is activated.
13	ON/OFF Indicator	Lights when the ON/OFF key has been pressed.
14	FL/R Key	Used to end an outside call and to either restore outside dial tone or switch to external dial tone status without hanging up the receiver.
15	REDIAL Key	Used to redial the last number dialed.
16	MEMORY Key	Used to access speed dialing or enter account codes.
17	ON/OFF Key	Used to make a call without lifting the handset or to turn the speaker on and off.
18	LINE Key	Used to seize a free line from MCO outgoing group.
19	VOLUME Key	Used to adjust the level of tones, background music, ringing, receiver volume, and display contrast.
20	HOLD Key	Used to hold calls, to retrieve held calls, and to complete FF key programming.
21	Microphone	Used to talk to another party without using the handset.
22	Speaker	Outputs tones and voice at your extension.

12-Key Large-Display Telephone key layout

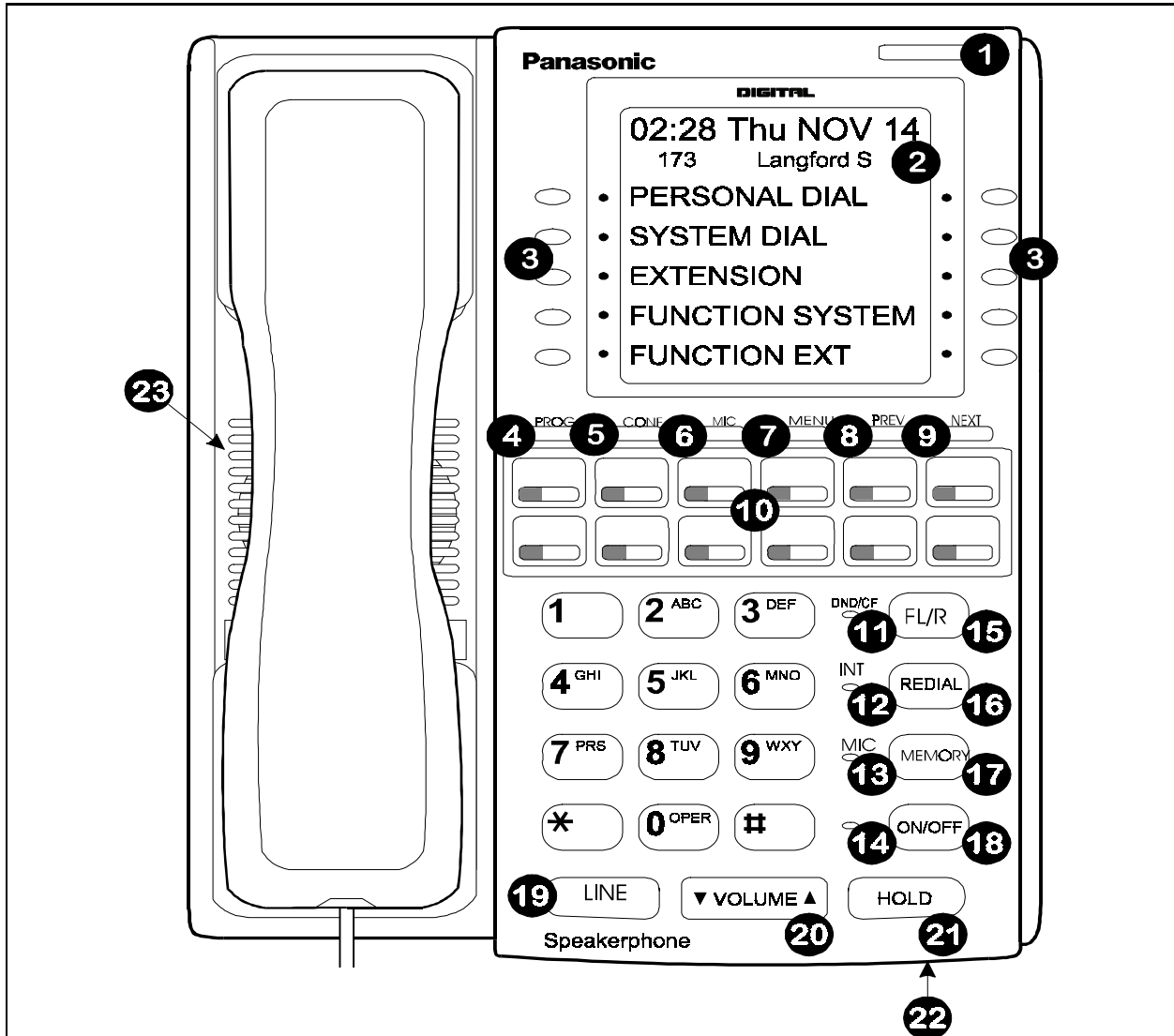

Large-Display Telephone Features

No.	Feature	Description
1	Message Waiting Indicator	Indicates that you have a message.
2	Display	Displays information about the phone's status, menus, and dialing directories.
3	Soft Keys	Used to select menus, directories, speed dial numbers, and to access call-handling features.
4	PROG Key	Used to program FF and one-touch keys, to adjust ringer volume and to send a flash signal. Depending on the setup of your system, may also be used to transfer calls.
5	CONF Key	Used to establish conference calls and to check Flexible Function (FF) and one-touch key settings.
6	MIC Key	Used to turn on the microphone to answer back with hands-free.

No.	Feature	Description
7	MENU Key	Used to return to the default Main Menu screen which contains the following items: <ul style="list-style-type: none"> • Personal Dial • System Dial • Extension • Function System • Function Ext
8	PREV Key	Used to return to the previous screen.
9	NEXT Key	Used to advance to the next screen.
10	Flexible Function (FF) Keys	Used to access outside lines or to access system features.
11	DND/CF Indicator	Indicates that Do-Not-Disturb (DND) or Call Forwarding is set.
12	EXT Indicator	Lights when you are on a call and flashes when you hold a call.
13	MIC Indicator	Indicates that your microphone is activated. Lights solid when your hands-free microphone is activated.
14	ON/OFF Indicator	Lights when the ON/OFF key has been pressed.
15	FL/R Key	Used to end an outside call and to either restore outside dial tone or switch to external dial tone status without hanging up the receiver.
16	REDIAL Key	Used to redial the last number dialed.
17	MEMORY Key	Used to access speed dialing or enter account codes.
18	ON/OFF Key	Used to make a call without lifting the handset or to turn the speaker on and off.
19	LINE Key	Used to seize a free line from MCO outgoing group.
20	VOLUME Key	Used to adjust level of tones, background music, ringing, receiver volume, and display contrast.
21	HOLD Key	Used to hold calls, to retrieve held calls, and to complete FF key programming.
22	Microphone	Used to talk to another party without using the handset.
23	Speaker	Outputs tones and voice at your extension.

CHAPTER 3 - SYSTEM FEATURES

OVERVIEW

This chapter describes the numerous system-wide features that are available with the ICX. The first part of this chapter highlights the most popular features in alphabetical order. Following these highlights is a complete list of system features and the ICX versions to which they apply.

POPULAR SYSTEM FEATURES

AUTO DAY/NIGHT MODE

Description:

The ICX system provides three different modes of operation. We call them Day 1, Day 2 and Night mode. Each of these modes can have a different Attendant as well as different ringing position assignments for extensions. The system can be programmed to automatically switch in and out of any one of these modes at a preset time each day. Weekends, holidays, and other special days can also be programmed with their own separate modes.

Benefits:

- Enables the system's ringing and dialling capabilities to change automatically when the mode is switched.

Applications:

- Lines that need to be switched over to an answering machine or Voice Mail system after-hours
- Lines that require toll restrictions after-hours so unauthorized personnel cannot dial long distance
- Different mode for lunchtime operation

AUTOMATIC ROUTE SELECTION (ARS)

This feature enables the system to select the most appropriate route for an outgoing call (i.e., the cheapest one). Working in conjunction with Toll Restriction Service (TRS), the call can also be denied based on the TRS level for the station (or user) placing the call.

There are three levels of ARS, based on the number dialled after the ARS access code:

- **Direct Route Selection.** The simplest form of ARS routing. Directly selects the trunk group and (if programmed) modifies the dialled number by deleting some of the first digits dialled, and/or adding digits to the beginning or end of the dialled number.
- **Route List Selection.** A more complex routing method that includes up to 5 alternative levels of route selection, and includes a TRS check.
- **Time List Selection.** The most complex routing method that determines the appropriate route list based on the day and time.

For "exceptions to the rule" such as holidays, up to 20 Special Days can be defined in programming with their own separate ARS routing methods.

Itemized Codes (used when sending the calling extension's number to the CO) and Authorization Codes (used when sending a system identifier code to the CO) can be defined in ARS

programming, and entered as part of the digits automatically added to the beginning or end of the dialled phone number. (The user won't even know these Codes are being dialled.)

Forced ARS (where the user must dial an ARS access code to be able to dial-out) can be enabled/disabled via the Extension COS assignment.

Benefits:

- Lets the customer (management) control the routing of outgoing calls by defining the route to be selected.
- Provides an effective means of cost control for expensive long-distance calls.
- Provides greater security, as end-users don't need to know the Itemized Codes or Authorization Codes used to place calls to the CO.

CALL TRAFFIC REPORTING

Description:

Traffic data can be stored and printed for intercom calls, incoming trunk calls, and outgoing trunk calls.

Benefits:

- Information can be used to evaluate CO line usage and control costs.

CALLER ID (CID)

Description:

Caller Identification (CID) is an optional service offered by your local telephone company which adds the following functions to a display phone:

- q **LCD indication of caller information.** Users can see calling number information displayed while the incoming call is ringing their extension. This includes ISDN digital messaging through the D-channel.
- q **Log of caller information.** The Call Log keeps a record of the last 10 CID calls received at an individual phone, and allows the user to view the Log and select from it to place a call. Up to 20 phones per cabinet can have the Call Log feature.
- q **SMDR recording.** CID information can be sent to the RS232C serial port so that it can be printed to a serial printer or call accounting system.
- q **CID notice to CTI.** CID information sent by the CO can be output to TAPI and other CTI devices.

Benefits:

- Allows users to handle calls more efficiently by knowing who is calling before they answer.
- Enables users to return calls that ring unanswered at their phones.

CLASS OF SERVICE (COS) RESTRICTION

Description:

Specific feature restrictions can be placed on extensions or on trunks. There are up to 16 definable classes of service for extensions, and 16 more for trunks. If no COS is assigned, all features are allowed.

Benefits:

- Allows users to have telephones more customized to their needs.

Applications:

- Users with Single Line Telephones (SLTs) or those who need to limit access to various features on selected telephones

COMPUTER TELEPHONY INTEGRATION (CTI)

Description:

For desktop computer-driven applications on a station-to-station basis, the Panasonic ICX offers powerful computer/phone integrations for the Attendant position (via our **PC Attendant Console**) as well as end-user phones (via our **PC Phone**). For more information about these CTI applications, see Chapter 5 - Special Applications in this document.

Benefits:

- Enables customers to operate more efficiently by taking advantage of the latest telephone and computer convergence. These industries are coming together to offer a more intelligent and streamlined way to do business.

Applications:

- Control and pull up information on your “on-screen” phone based on caller information
- Allows computer applications to control telephone operation

CONFERENCING

Description:

A user can conference up to three parties per conference or with additional hardware, up to eight parties per conference. Since the system is digital, there is no internal dB loss. However, additional dB gain/loss settings can be programmed for conference calls.

The ICX offers two types of conference calls. With **3-party conferencing**, there is a maximum of 2 outside lines per conference. With **8-party conferencing**, one outside line and up to 7 extensions can conference-in.

Benefits:

- Enables users to create their own conference calls without the use of auxiliary equipment.
- Saves time and money associated with conferencing geographically separated employees/customers.

Applications:

- System accommodates up to eight simultaneous three party conference calls. (The Busy Override function can be used to set up conference calls.)

DATA SECURITY

Description:

Data Security makes it possible to prevent interruptions on a phone. This feature is often used when the phone is hooked up to a modem, but it could also be used for confidential or sensitive calls. Data Security can be implemented for all phone usage, or it can apply only to outside line use.

Benefits:

- Ensures confidentiality on important calls.
- Protects data transmissions from being interrupted or cut off.

Applications:

- Modem phones
- Sensitive accounts (i.e., lawyers, doctors, etc.) where confidentiality is important

DELAYED RINGING

Description:

An incoming or transferred call as well as intercom calls can be programmed to ring at a secondary answering position if the call rings the primary answering position more than a specified length of time. The call can be programmed to ring at one or more delay ringing positions (including phones with BLF keys).

Benefits:

- Ensures that a call does not go unanswered or ring for an extended period of time.

Applications:

- Any company that experiences short, temporary periods of high traffic and needs to ensure that calls are answered

DIRECT INWARD SYSTEM ACCESS (DISA)

Description:

Any number of CO lines can be assigned to DISA lines which after being accessed, will enable the incoming caller to dial any extension within the system. Or, if the proper security code is entered, the caller will be able to access outside lines. Remote programming can also be done over these lines after entering a password.

Benefits:

- Allows internal personnel to access the system without tying up the attendant or other lines coming into the system.

Applications:

- Field sales people, repeat customers, etc.

DISTINCTIVE RINGING

Description:

Distinctive CO line ringing patterns can be set up for each extension, so the user can tell which trunk is ringing. If no distinctive ringing is assigned, then the ringing pattern of the CO line will be heard.

Benefits:

- Allows users to recognize the ring of their individual telephones or of the group of telephones that are in their group.

Applications:

- Companies with separate departments or large, open bullpen areas

FLEXIBLE DIAL PLAN

Description:

The ICX's dial plan is flexible. This means that the system comes with a default set of feature codes, which can be changed. (For example, the default Call Forward-All Calls feature code is 721. But you can change it to 7, or 2#, or ***, or anything else between 1 and 4 digits long.)

It also means that you can have two different sets of feature codes for each system, dividing extensions into two different groups (for example, SLT phones can have a different set of feature codes from digital extensions). Each extension can be assigned Dial Plan #1 or Dial Plan #2.

Benefits:

- Analog and digital phones can each have a unique set of feature codes.

Applications:

- When the ICX replaces another PBX system, the ICX feature codes can be programmed to match the old PBX's codes (one less thing for end-users to learn)

FLEXIBLE RINGING ASSIGNMENT

Description:

Ringling assignment is completely flexible so any CO line can be assigned to ring at any station with a line-appearance key. This ringling assignment can differ in Day 1, Day 2, and Night modes depending on user requirements. In addition, Virtual keys can be used for second, third, etc. ringling positions on a single phone.

Benefits:

- Assures coverage for outside lines, increasing customer satisfaction.
- Allows for customization of the system in order to meet a wide variety of applications.

Applications:

- Any organization that is separated from main answering position
- Departments that continue operations after receptionist switches system into Night mode can continue to make and receive calls

“HOWLER” TONE

Description:

If any phone is unintentionally left off-hook, the phone will emit a “howler” tone so someone nearby will notice and hang it up. This feature can be enabled/disabled system-wide, and the timer for it is also programmable.

Benefits:

- Helps keep phones or trunk lines from being inadvertently tied up because someone didn't put the handset back in the cradle.

HUNT GROUPS

Description:

Calls can be automatically transferred via one of 4 different automatic hunting modes. If a telephone is busy, the call hunts the next telephone in the group. If all members of the hunt group are busy, the call is queued until one of the members becomes available. Or, if the call remains unanswered, it is sent to the next member after a programmable period of time. The call can also be sent to another group or extension after exceeding the hunt group overflow timer. This timer can be set from 1 to 255 seconds; or the timer can be set to 0 so the call will not leave the group.

Up to 72 hunt groups of 20 members each can be set up for each ICX system (maximum 12 hunt groups per cabinet), with each hunt group having its own characteristics. If desired, Next Extension / Hunt Group lets you specify which extension or Hunt Group search after the Queuing Timer expired.

Benefits:

- Allows calls to hunt among a group of extensions designated as attendants, or customer service groups where a group of people answer the same calls, or for integration with Voice Mail or Automated Attendants.

Applications:

- Customer service departments, sales & marketing divisions, technical support groups

MULTIPLE DIRECT INWARD DIAL (DID) ASSIGNMENT (FOR ISDN)

Description:

This feature allows a DID number to ring on more than one telephone through the use of virtual ports. Also, one telephone can have multiple DID numbers assigned to it.

Benefits:

- Improves coverage of DID numbers and allows more flexibility in how an end-user can program the numbers.

Applications:

- Executive suites, travel agencies, answering services

RECALL TIMERS

Description:

The ICX is equipped with various system-wide recall timers that help direct unanswered (maybe forgotten) calls to someone who can answer them:

- q **Start Recall from Hold** - how long a call will remain on hold before recalling (ringing at) the extension, SLT, or Attendant that put it on hold. Each of these destination types has its own separate recall timer.
- q **Start Recall from Transfer** - the maximum amount of time a transferred call will ring unanswered before it goes back (starts ringing at) the phone that made the transfer. Attendants have their own Transfer Recall Timer, separate from extensions and SLTs.
- q **Recall Duration** - how long a recall will ring before reverting to the default phone position (usually the Attendant).
- q **Reversion Duration** - how long a reverted call rings the Attendant Group before being disconnected (this can be set to “ring indefinitely”).

Benefits:

- Improves call handling efficiency and ensures that held/transferred calls will not be lost or forgotten.

SLIDE RINGING

Description:

This is a type of delayed ringing for CO line FF-keys. You can program a CO line to ring incoming calls on certain phones first, then (if they remain unanswered) have them start ringing on phones that have a CO line FF-key appearance for that trunk. You can enable/disable this feature on individual extensions and individual trunks. You can also set a timer for determining when Slide Ringing begins on the FF-keys.

Benefits:

- Provides delayed ringing for multiple line-appearance calls.

STATION MESSAGE DETAIL RECORDING (SMDR)

Description:

By attaching a serial printer to the RS232C port, a detailed record of all incoming and outgoing calls, can be kept for future reference.

Through programming, the titles for each page can be removed to allow for connection to call accounting services.

The following is an explanation concerning the output format and display contents for call data:

Output Data Format

<u>Format #1</u>										
<u>T</u>	<u>MM/DD</u>	<u>HH:MM:SS</u>	<u>HH:MM:SS</u>	<u>NNNN</u>	<u>TTT</u>	<u>dddddddddddddddddddd</u>	<u>aaaaaaaa</u>	<u>vvvvv</u>	<u>H</u>	
①	②	③	④	⑤	⑥		⑦	⑧		
<u>Format #2</u>										
<u>T</u>	<u>MM/DD</u>	<u>HH:MM:SS</u>	<u>HH:MM:SS</u>	<u>NNNN</u>	<u>TTT</u>	<u>dddddddddddddddddddd</u>	<u>dddddddddddddddd</u>	<u>aaaaaaaa</u>	<u>v</u>	
①	②	③	④	⑤	⑥		⑨		⑦	
<u>vvvv</u>	<u>ccccccc</u>	<u>H</u>								
⑧	⑩									

① Condition Code:

Incoming Calls	Outgoing Calls
I: Incoming call	F: Call forward outside call
D: DID.DDI incoming call	H: Hold outgoing call
h: Hold incoming call	L: LCR outgoing call
N: Network incoming call	O: Outgoing call [Non LCR]
S: DISA incoming call	T: Transfer outgoing call
t: Transfer incoming call	W: Network outgoing call

② Call Start Time:

MM = 01 to 12 / DD = 01 to 31 / HH = 00 to 23 / MM = 00 to 59 / SS = 00 to 59

③ Call Duration Time:

HH = 00 to 23 / MM = 00 to 59 / SS = 00 to 59

④ Extension No.:

Extension No.: 0 to 9999

⑤ CO Line No.:

CO line No.: 1 to 576 / When CO line is disconnected while the call is on hold: *1 to *576

⑥ Dialed No.:

24 digits max. including **0-9**, *, and #. Cannot display Flash or Pause. If a number is hidden, * will appear instead of digits. * will stay with the call even if the call is transferred.

⑦ Accounting Code (Unverified):

10 digits max.

- ⑧ **Accounting Code (Verified):**
Verified ID code table number V001 to V400
 - ⑨ **Caller Data:**
Format #2 only
 - ⑩ **ISDN Charge Data:**
Format #2 only - originator number applies to ISDN only
- H Carriage return line feed

NOTE: Centrex and PBX codes, as well as ARS access codes, do not appear as dialled digits. If the Caller ID Feature is installed and enabled, "Private" appears for calls with restricted Caller ID display, and "Out of Area" for long-distance calls that do not provide Caller ID information.

Benefits:

- Provides accounting management tool for allocation of telephone expenses.
- Identifies areas for system or feature upgrade.
- Provides customer with record of telephone usage which can be used in making budgetary and planning forecasts.
- Prevents telephone abuse and misuse by identifying unauthorized outgoing calls.
- Provides personnel evaluation tool to measure amount of employee's time spent on the telephone.

Applications:

- Customers whose operation requires call tracking capabilities (e.g., lawyers, consultants, etc.)

SYSTEM SPEED DIALING (SSD)

Description:

The system can store anywhere from 80 to 800 SSD bin numbers that can be accessed by any user. Selected users can program the SSDs on their extension phones (the phones can be enabled for it in programming). The phone numbers stored inside the SSD bins can be up to 24 digits in length. End-users can "chain" up to 6 SSDs together inside a PSD (Personal Speed Dial) bin, to handle phone numbers that are longer than 24 digits.

On a proprietary telephone, the SSD numbers would be accessed by either pressing a programmed Flexible Feature (FF) key, or by dealing "MEMORY" and the SSD bin number (00-79 or 000-799). Or, on display phones, a user can select an SSD to dial by displaying an SSD Index, showing a list of current SSDs in the system. Individual phones can be programmed to display (or not display) the phone number being dialled when the user enters the SSD bin number to place the call. SSDs can be used to override toll restriction, if allowed in system programming.

Benefits:

- Saves time and increases productivity by allowing the user to use abbreviated dealing to access frequently called numbers.

Applications:

- General business environment where many people call the same locations or customers

TOLL RESTRICTION SERVICE (TRS)

Description:

TRS lets you control user access to outside lines on a per-station and per-line basis. It can be combined with ARS to block calls based on the number dialed, the outside line used, the extension phone used, the time of day (via Day, Night and Night 2 modes), and/or the day of the week/month/year.

- q A TRS Class can be assigned to each extension and trunk. Up to 50 different TRS Classes are available.
- q Each TRS Class is then assigned to a TRS Level. It is this Level that is used as the basis for allowing/restricting calls.
- q There are 10 TRS Levels available. Level 0 denies all calls. Levels 1-8 can be partially restrictive per assignments. Level 9 allows all calls.
- q TRS can restrict the number of digits dialed (1-20 digits, or no limit).
- q TRS can restrict the use of SSDs for outdialing, based on TRS Class assignments. Either all SSDs or a range of them can be restricted.
- q TRS can also restrict the dialling of * and #, again based on TRS Class assignments.
- q The same phone can have different TRS restrictions during Day and Night modes.

Benefits:

- Controls toll calling expenses by allowing the customer to define an individual station's capability to use outside CO line groups.
- Prevents toll calling abuse by providing automatic blocking of calls placed to restricted phone numbers.

Applications:

- Cost-conscious customers who wish to control telephone expenses

WALKING TRS

Description:

A user can use his or her calling privileges at another extension by entering a 4-digit (0-9) ID code. This enables the other extension to temporarily have CO line access capabilities which are defined by the Toll Restriction Service (TRS) data of the user's extension. When the user hangs up the telephone, the extension returns to its original TRS type. (This allows a user to make a call from a telephone that is normally restricted, such as a warehouse phone or lobby phone.)

NOTE: The Walking TRS code must be programmed at the user's extension before it can be entered at a different extension. The same code can be programmed on multiple extensions.

The entered Walking TRS code will show up on the SMDR report as: "Wnnnn" (W means Walking TRS code; nnnn is the 4-digit code).

Since a phone can have a different TRS Class assignment during Day, Night and Night 2 modes, the Walking TRS codes will follow these assignments. So, for example, long-distance calls can be allowed on the phone during the day, but restricted at night.

Benefits:

- Allows a telephone to be restricted, but still allows certain users to override the restriction.

Applications:

- Warehouse telephones, waiting area, etc. Warehouse telephones, waiting area, etc.

LIST OF AVAILABLE SYSTEM FEATURES**System Features**

Features	Notes
Alarm Ringing for Unanswered Calls	
Alarm Tone for Lengthy CO Calls	
Analog Device Compatibility	
Attendant Group	not applicable on Single Line Telephones (SLTs)
Auto Day/Night Mode	
Automatic Route Selection (ARS)	
Automatic Trunk-to-Trunk Transfer	
Background Music (BGM) / Music-on-Hold Separation	
Battery Backup	
Behind PBX/Centrex Compatibility	
BLF Ringing	
Building Block (up to 6 cabinets)	
Built-In 2-Way Voice Mail	
Built-In ACD	
Call Progress Tones	
Caller ID (for ISDN)	available on display phones only
Class of Service (COS) - CO/TIE Feature	
Class of Service (COS) - EXT-EXT Restriction	
Class of Service (COS) - Extension Feature	
Class of Service (COS) - TRK-TRK Restriction	
CO Trunk Interface (ISDN BRI)	
CO Trunk Interface (ISDN PRI)	
CO Trunk Interface (Loop Start)	
Computer Telephony Integration (CTI) Capability	
Data Security	
Delayed Ring	
Delayed Ring - Day/Night Modes	
Digital Pad Settings for Automatic Volume Adjustment	
Direct Inward System Access (DISA)	
Distinctive Ringing for Incoming CO Line Calls	not applicable on Single Line Telephones (SLTs)
Door Box Connection (CO Connection)	
Door Opener	
Flexible Numbering	1-4 digits in Extension Nos. changeable Feature Access Codes
Flexible Station Functions	available on large-display phones only
Free Slot	
Hot Line	
Howler Tone for Lengthy Off-Hook/Dial Tone	
Hunt Group Pilot Number	

Features	Notes
Hunt Groups - Circular	
Hunt Groups - Pilot Distributed	
Hunt Groups - Pilot Terminal	
Hunt Groups - Switch Back	
Integrated Services Digital Network (ISDN)/BRI S-Point Interface	
Integrated Services Digital Network (ISDN)/PRI S-Point Interface	
Maintenance (local and remote)	
MCO Tenant Group	
Memory Backup	
Multiple Ringing	
Music-On-Hold - Internal	
Music-On-Hold - External	
Non-blocking Architecture	
Page Zones - External	up to 5 External page zones per system
Page Zones - Internal	up to 10 Internal page zones per system
PC Based Programming	
Port/Channel Close	
Power Fail Transfer	
Power On Maintenance (Extension/Trunk)	
Program Data Output	
Recall Timers	
Slide Ringing	
Soft Key Operation	available on display phones only
Speed Dialling	
Station Message Detail Recording (SMDR)	
Station Name Assignment	
System Fault Recording	
System Speed Dial (SSD)	up to 800 SSDs per system
System Speed Dial (SSD) Name Assignment	available on display phones only
System Speed Dial (SSD) Toll Restriction Override	
Telephone Programming	available on display phones only
Toll Restriction	
Traffic Measurement	
Trunk Group	
Trunk Name Assignment	available on display phones only
Virtual Port (Floating Park)	
Virtual Port (Virtual Extension)	
Voice Mail Integration	
Voice Recognition	requires Adapter Kit for each phone

CHAPTER 4 - STATION FEATURES

OVERVIEW

soft keys soft keys ICX This chapter describes the many features that end-users can perform on ICX station phones. Some of the most popular functions are highlighted below. A complete list of Station Features is included at the end of this chapter.

POPULAR STATION FEATURES

ACCOUNT CODE CAPABILITY

Description:

This feature works with Station Message Detail Recording (SMDR). During a phone call, a station user can silently enter an accounting or client billing code. The entered Code will display on the phone's LCD as it's dialed, so the user can tell it's being registered. Then later, the SMDR reports will show the Code dialed for each call, and even sort the report by these Codes.

There are two different types of account codes you can use in the ICX:

Non-Verified Account Codes

Non-Verified Codes aren't checked by the system for validity; the user can enter anything from 1-10 digits long. Individual phones can be programmed to accept *forced* Account Codes (the user must enter a code for every call) or *voluntary* Account Codes (the user can enter a code, but doesn't have to, for each call).

Non-Verified Account Codes can be assigned to incoming and/or outgoing calls. For incoming calls, the user can enter the Code one-time during the call. For outgoing calls, the user either enters the Code before accessing an outside line (for *forced* Codes), or one-time during the call (for *voluntary* Codes).

Verified Account Codes

Verified Account Codes entered by phone users must match a 4-digit code that has been preprogrammed into an Account Code Table. (It is possible to enter up to 10 digits for a Verified Account Code; however, only the first 4 digits will be used to verify the code.) These codes can also be either *forced* or *voluntary*. You can program these codes with their own Toll Restriction Service (TRS) Class assignment so that, when entered, they will override the extension's TRS Class. Thus, Verified Account Code users can "float" from phone to phone, placing calls that would normally be restricted on that phone.

Benefits:

- Provides a way to allocate telephone expenses (outgoing calls) to specific clients/ departments as a cost accounting tool.
- Doesn't limit the expense allocation by phone; the Account Codes are specific to the phone *users*, not to the *phones*.
- Displays the entered Account Code on the phone's LCD, allowing the user to verify it immediately.

- Provides record-keeping confidentiality by allowing the user to enter the Account Code while the call is in progress, without interrupting the conversation or showing any other indication to the outside party.

Applications:

- Customers who need to track outgoing calls so they can bill clients such as lawyers, accountants, etc.
- Customers who allocate phone call expenses by project

ALARM RINGING

Description:

If an incoming trunk call rings unanswered for a (programmable) period of time, the call's ringing pattern and dB level changes automatically so users can tell which calls have been ringing longer. You can program the pattern and level of the ringing. You can also enable this feature on some trunks, and disable it on others.

Benefits:

- Users can distinguish between calls that have been ringing longer than others.

Applications:

- Noisy office environments; heavy call traffic

ALARM TONE FOR LENGTHY CALLS

Description:

If a user is on a phone call for a long time, an alarm tone sounds intermittently in the handset receiver. This feature can be turned on/off system-wide in programming. If you turn it on, you can also enable/disable individual phones and trunks for it, as well as programming the amount of time before the alarm goes off.

Benefits:

- The ICX can automatically monitor call duration, and let users know when they've been on a phone call too long.

ATTENDANT CALLING

Description:

With this feature, multiple phones can serve as Attendant consoles via a programmed Attendant Hunt Group. When a phone user dials "0" to reach an operator, the first Attendant member phone in the Hunt Group rings. If it continues to ring unanswered, the call goes to the next Attendant member; and so on. Or you can program some of the members to ring simultaneously.

Up to 20 extensions can be members of the Attendant Hunt Group. You can program a different Attendant Hunt Group to ring during Day1, Day2, and Night mode. If someone dials the member's actual extension number, the call won't enter the Hunt Group.

Benefits:

- The Attendant position isn't limited to just one phone. Different phones can act as the system operator position, depending on the time of day.
- Other phones can serve as backup positions for the Attendant phone.

AUTO-REPEAT DIALLING

Description:

If a user places an outside phone call and gets a busy tone, he/she can stay on the line and press REDIAL. The ICX will automatically hang up, re seize the trunk line, redial the call, and wait to detect busy or answer while the user is waiting. If it's still busy, the system will try again (at programmable intervals) until the called party answers, the user hangs up, or 14 more redials are attempted.

You can turn this feature on/off for individual extensions, and also enable/disable it on individual trunks. You can also program the amount of time the system waits to detect busy or answer, as well as the interval between redial attempts.

Benefits:

- An automatic feature that helps phone users save time and reduce dialling errors.

BACKGROUND MUSIC (BGM)

Description:

Users can set their phones to play Background Music on-speaker while the phone is idle. If the phone receives a call, or the user goes off-hook, BGM will go away until the phone becomes idle again. BGM can be turned off by dialling the same code that turned it on. BGM can have a different sound source than Music-On-Hold (MOH) (what callers hear when they get put on hold).

Applications:

- One sound source for employees (BGM, typically music), another for callers (MOH, such as recorded advertisements).

BUSY OVERRIDE (“BARGE-IN”)

Description:

An extension user can barge into a call on another extension, whether it's an outside or intercom call. Phones set to Do-Not-Disturb (DND) can also be barged into; see **DO NOT DISTURB** for more information.

When a barge-in occurs, a 3-party conference call is created; all three parties can hear each other and talk to each other. There are two ways to barge-in on a call:

- q **Extension Busy Override**, where the user dials the extension, gets busy tone, and dials a code to barge-in.
- q **CO Key Busy Override**, where the user presses the lit CO line key on his/her phone that represents the call in progress.

You can program the ICX to send an alert tone to all parties when the barge-in occurs. You can also allow/block the phone's ability to perform this feature based on the phone's Class of Service assignment (see **CLASS OF SERVICE** for more information).

Benefits:

- Allows operators, secretaries, bosses, etc. to interrupt calls in progress with urgent information or other calls that need to be answered.
- Provides a way to establish a 3-party conference between two users and an outside party, or between three users.

CALL DURATION DISPLAY

Description:

The length of a call in progress (minutes and seconds) is tracked and displayed on the phone's LCD.

Benefits:

- Users can tell how long they've been on a call -- and what the SMDR report is going to show for that call.

CALL FORWARDING

Description:

Call Forwarding allows users to automatically send their calls to another extension, to an outside line, or to Voice Mail. There are several different types of call forwarding to choose from (see chart below). All types can be set or canceled manually by the phone user. The user can also clear the phone of all of its Call Forward and DND settings with a single code. (Even if a telephone is in DND, a call can be transferred to it; the call will automatically go to the Call-Forward destination.) Users can also set/clear Call Forward settings on other extensions from their own phones.

Call Forwarding Types

Call Types to be Forwarded
All Calls
Busy
No Answer
Busy/No Answer
External Calls Only

Benefits:

- Provides a way to pick up calls for absent personnel who are not part of a call coverage group.
- Allows for integration of Voice Mail systems.

Applications:

- Sales, marketing, customer service, etc.
- Companies using Automated Attendant and/or Voice Mail

CALL PARK

Description:

This feature is often used with Paging. It's a type of transfer that doesn't involve the phone ringing; you simply "move" the call to another location. There are two types of Call Park:

- q **Virtual Call Park.** Also known as Park Orbit. Users can park the call to a Virtual extension, and page the person to pick up the call from any extension by dialling a Park Pickup code and the orbit number.
- q **Station Call Park.** The call can be parked onto another (physical) extension, when the user wants to walk over to another desk and conduct the call from there.

If the parked call isn't picked up, a programmable timer determines when it will return to the original extension.

Benefits:

- Better call handling capabilities.
- When a party cannot be reached at his/her phone, a user can “park” the call and page the party to pick up the call.

CALL PICK-UP

Description:

Phone users can pick up calls ringing on another (single) extension, other (multiple-ringing) extensions, in an Extension Group, on a specific trunk, or in an MCO Trunk Group. Almost any type of call can be picked up, including DID/DISA calls, network calls, and voice intercom calls.

Benefits:

- Allows phone users to pick up calls, no matter where they’re ringing, without leaving their workstations.

Applications:

- Customers who need call coverage for unattended stations
- Organizations with department structure
- Customers who presently have a key system operating behind a PABX to provide group pick-up capability

CALLBACK REQUEST

Description:

A phone can alert its master (the user) when another, busy extension becomes free. Say Extension “A” calls Extension “B” who is busy. “A” can dial a Callback Request code, hang up, and concentrate on other things. When “B” becomes free, “A” will ring. When the “A” user picks up the handset, the “A” phone will automatically ring the “B” phone.

Benefits:

- The user doesn’t have to keep redialing a busy extension. The phone does all the work.

CALLER ID CALL LOG

Description:

The Call Log keeps a record of Caller ID calls to individual phones. The Call Log allow you to view Caller ID calls that have been sent to your phone and, if desired, return or call. per CCU, 20 extension can use this feature. Max. 10 logs per extension.

CAMP-ON (CALL WAITING)

Description:

You can program phones to be able to “camp-on” calls to other extensions. This in effect “queues” the call onto a busy extension. On phones that are programmed for **Automatic Camp-On**, put the call on hold, dial the extension to transfer the call to, and hang up. (For **Manual Camp-On**, users dial a Camp-On code before hanging up.) The busy extension will receive a splash tone in the receiver, and/or a confirmation tone on-speaker (both tones can be turned on/off in programming).

To pick up a camped-on call, either hang up from the current call and then go off-hook again, or put the current call on hold. You’ll be automatically connected to the caller.

Benefits:

- Users only have to call a busy extension once. They don't have to wait for the station to become free, or interrupt the current call, to transfer a waiting call to it.

Applications:

- Any user who wants to be notified of another call, without the current caller being aware of it
- Attendants who don't have time to wait for extensions to become free before transferring calls to them

CONFERENCE CALLS

Description:

Users can include other parties in an existing call. The ICX offers **3-Party Conferencing** which can consist of:

- q 1 extension + 2 CO lines
- q 2 extensions + 1 CO line
- q 3 extensions.

There's also **8-Party Conferencing** with 1 CO line and up to 7 extensions, or up to 8 extensions. This requires an extra Conference Card (VB-44120) installed in the ICX cabinet.

Applications:

- Employees in separate buildings who want to hold meetings over the phone
- Telemarketing applications where a station user needs to conference-in a Supervisor for assistance

DO-NOT-DISTURB (DND)

Description:

DND enables station users to stop all transferred intercom and CO calls from ringing their station, but still be able to make outgoing calls. Anyone who calls the DND station will hear a distinctive busy signal. But individual phones can be programmed with the ability to override DND settings on other phones.

Benefits:

- Enables a user to quickly and easily initiate privacy for important meetings, etc.

DP-TO-DTMF SIGNAL CONVERSION

Description:

While on a DP (dial pulse) trunk, a user can switch to DTMF (dual tone multi-frequency) signaling by pressing the Q or # key. DTMF signaling is required whenever additional digits are dialed after connecting to an automated answering system such as Voice Mail, Auto Attendant, etc.

You can program the ICX to automatically change DP to DTMF tones based on incoming and outgoing timer programming.

Benefits:

- Users can send DTMF signal to the other party (such as a bank computer or Voice Mail) to specify service numbers.

Applications:

- Users dialling into a Voice Mail or Auto-Attendant system on a DP trunk. They'll need to switch to DTMF signaling to select Voice Mail options by dialing numbers on the

phone when prompted. (for example, they'll hear: "To reach Sales, press 1. To reach Purchasing, press 2.")

DSS/BLF KEYS

Description:

With the Direct Station Select/Busy Lamp Field feature, a phone's FF-key can be programmed to represent another extension. The phone user can perform the following using DSS/BLF keys:

- q **Monitor the extension's current status.** The DSS/BLF key will be lit red when the extension it represents is currently busy. It'll flash when there's an incoming call ringing to that extension. Or, it'll be blank (unlit) while the extension is idle.
- q **Call the extension.** Just press the (unlit) DSS/BLF key to ring the extension. Or, transfer a call to the extension. No pressing Hold, no dialing the extension number, no transfer codes. Just press the DSS/BLF key. It's that simple.
- q **Pick up the extension's calls.** Again, just press the DSS/BLF key while it's flashing. You'll immediately connect to the caller.
- q **Delay-ring the extension's calls to your phone.** After a programmable period of time, your phone will ring for the extension's unanswered calls. Press the flashing DSS/BLF key to answer the call.

Benefits:

- Users can monitor calls to other extensions, and answer them if no one else does.
- Users can transfer calls to an extension simply by pressing the DSS/BLF key for it.

Applications:

- Receptionists, secretaries, operators -- anyone who needs a quick and simple way to get calls to, and receive them from, other extensions

DUAL-COLOR LEDS

Description:

Each LED key has dual colors underneath. Red is a busy CO line and green is the CO line you are speaking on. These dual colors are utilized to indicate busy or DND stations.

Benefits:

- Lets users know what CO line they're talking on, especially when they put the call on hold.
- Helps users monitor the status of stations (if the key is being used as a DSS/BLF).

Applications:

- Systems that are designed as "squared," and multiple lines appear on telephones
- Boss/secretary applications

FLEXIBLE FEATURE KEYS ("FF-KEYS")

Description:

Every FF-key on a telephone can be programmed by the end-user for a variety of one-touch features. The following is a list of some of those features:

- | | | | |
|-----------------|-----------------------------|----------------------------|-------------------------|
| • Account Codes | • Conferencing | • Headset On/Off | • Paging |
| • Alarms | • Dial Tone On/Off | • Intercom Calling | • Pooled CO Line Access |
| • Answer Key | • Direct Appearing CO Lines | • Least Cost Routing (LCR) | • Release Key |
| • Barge-In | • Direct Call Pickup | • Meet-Me Answer | • Speed Dialing |
| • BGM | • DND | • Message-Waiting Send | • Station Lockout |

- Call Forwarding
- DSS/BLF
- Mute Key
- Switch to Voice Calling
- Group Call Pickup
- Night Transfer
- Voice Mail Access

Benefits:

- Flexibility to custom-configure a telephone to suit the individual user's needs.
- Easy one-touch feature access, instead of having to remember (and dial) codes.

HANDS-FREE ANSWERBACK

Description:

Station users receiving an intercom call can answer a Voice call on-speaker, without picking up the handset or otherwise touching the phone. Individual phones can be initially set for Voice calling via the Extension COS (Class of Service) assignment in programming. Extensions can also be individually enabled or disabled for Send Voice Calls and Receive Voice Calls (again, via the Extension COS assignment). If a user begins a Tone call, he/she can switch to Voice calling by dialing "1". A "splash" tone alerting the called party of the on-speaker condition can be enabled/disabled system-wide.

Benefits:

- Users can answer intercom calls without touching the phone.

HEADSET CAPABILITY

Description:

A proprietary phone's FF-key can be programmed for activating/deactivating Headset Mode on the phone. When it's activated, all audio (including the speaker) is switched to the Headset jack, and the "RELEASE" and "ANSWER" buttons replace handset on/off-hook functions.

Benefits:

- Increases user efficiency by allowing headset operation from any proprietary telephone, eliminating the need to lift or hang up the handset.

Applications:

- Attendant position, customer service, etc.

HOLD

Description:

With its Call Holding features, the ICX lets you control who can pick up a call on hold:

- q **System Hold:** Anyone can retrieve the held call from their own phone.
- q **Exclusive Hold:** Only the person who put the call on hold can retrieve it.
- q **Floating Hold:** A kind of System Park where the user can transfer the call to a Floating Hold key, and any phone with that key (set according to a programmable dial plan) can pick up the call.
- q **Brokers Hold:** A user can toggle between two calls by pressing HOLD (one call is current, the other is on hold).

Benefits:

- You can limit the number of people who can pick up a call on hold.
- You can allow anyone to be able to pick it up, no matter where it's put on hold.
-
-
-

HOT DIAL PAD

Description:

A user can simply walk up to a digital phone and start dialing without picking up the headset. The call immediately switches to the phone's speaker, and the entire call can be conducted on it. Of course, the user can pick up the headset anytime to take the call off-speaker.

This feature can be enabled/disabled on individual extensions in programming. There is no limitation on the number of digital phones that can have Hot Dial Pad. It'll work whenever the phone is idle, has another call on hold, or is receiving a page.)

Benefits:

- Calls can be initiated hands-free (no headset required).

Applications:

- Fast-paced environments
 - Emergency-dial situations
-

HOT LINE

Description:

Phones can be programmed to immediately connect to a preassigned extension or speed-dial number when somebody lifts the handset. (The user doesn't dial any digits.)

Applications:

- Lobby areas, elevators, etc. (for example, a sign above the phone that reads "For assistance, pick up the phone")
-

MEET-ME ANSWER

- Hot Line

Description:

Phones can be programmed to immediately connect to a preassigned extension or speed-dial number when somebody lifts the handset. (The user doesn't dial any digits.)

Applications:

- Lobby areas, elevators, etc. (for example, a sign above the phone that reads "For assistance, pick up the phone")
-

MEET-ME ANSWER

Description:

With Meet-Me Answer, a user can answer a page from any extension without having to run to a certain phone. All the user has to do is pick up the handset on the nearest phone, and dial the universal Meet-Me Answer Code (the default Code is ##) to connect to the initiator of the page.

Benefits:

- Users can answer their calls from any phone in the building.
- Attendants don't have to chase people down to relay important messages.

MESSAGE-WAITING/CALLBACK

Description:

This is similar to Call Waiting. The difference is, the called party isn't as obligated to call you back when they get off the phone. The Message-Waiting LED will be blinking on the called party's phone, and its LCD will also indicate the Message-Waiting callback request. The called party can go off-hook and press the MSG key to call you back. Or, he/she can ignore it. (The indications won't go away, but they won't interrupt anything else from happening on the phone, either.)

Benefits:

- A more polite, less urgent way to ask someone to call you back, when they get a minute.

Applications:

- Voice Mail. Whenever the user gets a new message in his/her mailbox, this is how the phone lets them know.

MUTE

Description:

Mute is often used as an alternative to putting a caller on hold. Say a station user is on a call. The boss walks up and start silently mouthing words to the user. Instead of putting the caller on hold, the user can press an FF-key programmed for Mute, to block audio to the outside party (or, if the call is on-speaker, press the MIC key). During that period MIC LED is blinking. The user can still hear the outside party. But the outside party can't hear the user. Or the boss, who can now speak freely. The user can re-establish audio by pressing the FF-key or MIC key again. MIC LED is changed to solid Red.

Benefits:

- There is no indication to the outside party (other than silence) that he/she can't hear the station user anymore.

NAME ASSIGNMENT

Description:

The ICX lets you create a more user-friendly, personalized system by allowing various name assignments that will display on phone LCDs. You can assign names to:

- q CO Lines
- q DID/DNIS Numbers
- q Extensions
- q Extension Index
- q Personal Speed Dial (PSD) Codes
- q System Speed Dial (SSD) Codes
- q SSD Index

Benefits:

- Customizes the various system features to your specific needs.

Applications:

- Executive suites, doctors offices, travel agencies

OFF-HOOK MONITORING

Description:

With Off-Hook Monitoring, a call can be conducted through the handset and on-speaker at the same time. After lifting the handset and placing/answering a call, the user can press the ON/OFF key to “share” the call on-speaker. The outside party can be heard both in the handset receiver and through the speaker. But the outside party can only hear the user talking through the handset. (The speaker won’t transmit.) This feature isn’t available during Headset Mode.

Benefits:

- Others nearby (such as Supervisors) can listen in on a call without conferencing-in.

OFF-HOOK SIGNALING

Description:

This applies to calls with multiple-line appearances (those calls that ring on multiple phones). Off-Hook Signaling sends a tone to a busy extension to indicate that another CO call has arrived. Off-Hook Signaling applies to direct calls, Automatic Camp-Ons, and Manual Camp-Ons.

Benefits:

- The user knows when a second or third call is ringing in (especially helpful for the Attendant).

ON-HOOK DIALING

Description:

With this feature, station users can dial out without picking up the handset, by pressing the ON/OFF key and then dialing the number. They’ll hear everything -- dial tones, DTMF signals, talk, etc. -- through the phone speaker. To take the call off speaker, just lift the handset.

Benefits:

- Easier dialing.
- Hands-free phone conversations on speakerphones.

OFF-HOOK VOICE ANNOUNCE (OHVA)

Description:

This is a type of barge-in that doesn’t include the outside party. A station user calls a busy extension and wants to break in. He/she dials a code, and is able to tell the busy extension of the important message through the handset. The busy extension user can (if desired) press a preprogrammed OHVA key to mute conversation to the outside party, and respond to the extension trying to relay the message. In the meantime, the outside party doesn’t hear what’s going on behind-the-scenes. To resume normal conversation with the outside party (and disconnect from the extension that broke in), press the OHVA key again.

Benefits:

- Allows more flexibility for users who want to be alerted that there are other calls or important messages waiting, without putting the outside caller on hold.
- Confidentiality.

Applications:

- Boss/secretary relationship

ONE-TOUCH KEYS

Description:

ICX phones have several different types of keys that can be programmed to execute features or store frequently-dialled numbers. Instead of dialing a series of digits, the user can just press the key. There are **FF-keys** (with LEDs that flash red or green, indicating certain features or phone status), **Labelled Keys** (that perform a specific function such as Hold, Flash, Mute, etc.), **Soft Keys** (surrounding the phone's LCD, that execute the feature name that's displayed on the LCD), and **One-Touch Feature Keys** (solid one-touch keys, not available on some phones, that store additional feature codes or frequently-dialled numbers).

Benefits:

- Gives users many one-touch options for performing features such as CO line access, camp-ons, barge-ins, etc.

PAGING

Description:

The ICX allows users to make both *internal pages* (heard on phone speakers) and *external pages* (heard over a loudspeaker system). Users can respond to pages for calls on hold with Meet-Me Answer. You can create up to 10 different internal and 5 different external paging zones, and an extension can belong to more than one of them. Paging Override settings are also available.

Benefits:

- Improves operating efficiency by providing dial access to paging equipment and to stations in designated paging zones.
- Improves customer satisfaction by facilitating a faster response to callers on hold.

PRIME LINE PREFERENCE

Description:

A phone can be programmed to automatically access an MCO trunk when the user goes off-hook or presses ON/OFF.

Applications:

- Users who need instant access to an outside line.

RINGING LINE PREFERENCE

Description:

This feature gives station users the ability to answer a ringing incoming call simply by lifting the handset or pressing ON/OFF. If this feature is disabled on the phone, the user must press the flashing CO line key to answer the call.

Benefits:

- Users can pick up calls quickly.

Applications:

- Easier access to ringing calls

SOFT KEY VARIABLE MODE

Description:

Soft Key Variable Mode allows Small-Display phone users to access frequently-used features through their soft keys, while the phone is in different call states such as during intercom call, during CO dial tone, during a trunk call, and during busy tone (after calling a busy extension).

Benefits:

- Provides easy feature access via customized phone keys.
- Displays the feature name next to the soft key during the call state in which it's available.

SPEED DIALING

Description:

Users can program any of their one-touch keys for speed-dialing. There's **Personal Speed Dial** codes which can be different on each extension (up to 20 SSDs per phone). There's also **System Speed Dial** codes (up to 800) that can be used by everyone. Some of the wonderful things you can do with these speed-dial codes in programming:

- q Set individual extensions to be able to override TRS restrictions with SSD numbers.
- q Chain SSDs and SSDs together (useful for entering account codes, navigating through automated answering machines, etc.).
- q Divide the SSDs into blocks and assign them to different phone areas.
- q Set the system to automatically select a trunk whenever an SSD or PSD is dialed.

Benefits:

- Saves time and increases productivity by allowing one-touch dialing of frequently-called numbers.

TRANSFER

Description:

The ICX's Transfer feature allows station users to transfer their outside line or inter-station calls without attendant intervention. Transferring calls can be either *supervised* by the user (who waits for the third party to answer, then announces the call before transferring it) or *unsupervised* (user hangs up before the third party answers). If the third party doesn't pick up, the call will return to the extension that originated the transfer. If that extension doesn't answer it either, the call will return to the Attendant Group.

Benefits:

- Provides efficient, user-friendly call handling capabilities.

WALKING TRS

Description:

By entering a Walking TRS (Toll Restriction Service) code on any phone, a station user can temporarily have access to the less-restrictive call capabilities of his/her own phone. For example, the user can walk over to another phone that is set to restrict long-distance calls, pick up the handset and dial his/her Walking TRS code (which is associated with the user's own phone), and be able to make a long-distance call. When the user hangs up, the -phone will return to its original TRS setting.

Benefits:

- Allow a telephone to be restricted, but still allows certain users to override the restrictions.

Applications:

- Warehouse phones, waiting areas, etc..

LIST OF AVAILABLE STATION FEATURES

Station Features

Features	Notes
Account Codes - 10-digit (Forced)	
Account Codes - 10-digit (Voluntary)	
Account Codes - 4-digit (Forced/Verified)	
Account Codes - 4-digit (Verified)	
Attendant Group Calling	
Auto Busy Redial	
Background Music	
Busy Lamp Field/Direct Station Select (BLF/DSS) Keys	
Busy Override ("Barge-In")	
Callback Request	
Call Duration Display	
Call Forward-All Calls	
Call Forward-Busy	
Call Forward-No Answer	
Call Forward-Outside	
Call Forward Destination Display	available on display phones only
Call Forward Set by Other Extension	
Call Forward Source Display	available on display phones only
Call Pickup - Direct (Extension/Trunk)	
Call Pickup - Group (Extension/Trunk)	
Call Pickup - Multiple Line Appearance	
Camp-On (Automatic)	
Camp-On (Manual)	
Conference (3-party)	
Conference (8-party)	requires Conference Card (VB-44120)
Dial Tone Shut-Off	
Direct CO Line Access	
Direct CO Line Answer	
Direct Station Selection Module - DSS/72	
Directory Display (Extension, PSD, SSD)	
Display - Call Status	
Display - Called Party	
Display - Calling Party	
Display - Date and Time	
Distinctive Ringing for CO Line Calls	

Features	Notes
Do Not Disturb	
Do Not Disturb Set by Other Extension	
DP-to-DTMF Signal Conversion	
Dual-Color LEDs	
Extension Directory	
Extension Module Connection - EM/24	
Flash	
Flexible Feature Keys	
Hands-Free Answerback	
Hands-Free Operation	
Headset Operation	
Hold (Brokers)	
Hold (Exclusive)	
Hold (Floating)	
Hold (System)	
Hot Line	
Interactive Screens	available on Large-display phones only
Intercom Calling - Tone	
Intercom Calling - Voice	
Key Bank Hold by DSS	
Line Appearances	
MCO Line Preference	
MCO Trunk Access	
Meet-Me Answer	
Message Waiting/Callback	
Mute	
Off-Hook Monitoring	
Off-Hook Signaling	
On-Hook Dialing	
One-Touch Keys	
Paging - Internal (Receive)	
Paging - Internal/External (Access)	
Personal Speed Dial (PSD)	up to 20 PSDs per phone
Personal Speed Dial Directory	
Personal Speed Dial Name Assignment	up to 7 characters
Prime Line Preference	
Redial Last Number	
Ringing Line Preference	
Speakerphone	available on speakerphones only
Speed-Dial Chaining	
Station Callback Display	available on display phones only
Station Function List	available on Large-display phones only
Step Calling	
System Speed Dial (SSD)	up to 800 SSDs per system

Features	Notes
System Speed Dial Directory	
Time & Date Display	available on display phones only
Time Reminder	
Transfer - Screened	
Transfer - Unscreened	
Trunk Queuing	
Trunk-to-Trunk Connection	
Voice Mail Transfer Key	
Voice Recognition	requires Adapter Kit for each phone
Volume Control - Handset	
Volume Control - Monitor (speaker)	
Volume Control - Ringing	

CHAPTER 5 - SPECIAL APPLICATIONS

OVERVIEW

The ICX is designed to accommodate a wide variety of features as described throughout this document. However, this powerful phone system is also designed to support fast-emerging technological trends and specialized 3rd-party product integrations. Listed below are some examples.

COMPUTER TELEPHONY INTEGRATION (CTI) (Future Feature)

CTI technology ties computers and phone systems together, allowing phone users to combine the advantages of both technologies for fast, accurate, effective response to incoming callers. It's a powerful tool for increasing customer satisfaction, which in turn increases sales for the company that has CTI built into their phone system. For example:

- q Customer information could be automatically displayed on a Customer Representative's computer screen, based on the caller's phone number.
- q A computer-based phone directory could be used to look up a phone number, and select it on-screen to automatically place the call.
- q PBX features such as call transfers, pickups, forwarding, etc. could be executed by clicking on a computer icon or responding to a screen prompt (no more trying to remember a feature access code or sequence).

Panasonic is constantly developing new, more powerful CTI applications to work with the ICX. These are the CTI products that are currently available:

PC PHONE

Our **PC Phone** is effectively a "Super-Executive Keyphone" which is designed to replace an extension phone. Comprised of a PC card (installed inside the computer), application software, and various connecting items (leads, handset, headset, etc.), the PC Phone connects to a ICX extension port and provides a sophisticated "on-screen" phone for the end-user. Some of the PC Phone's many features are:

- q **Flexible configuration.** It's easily configured by size or by features, to provide a simple interface that the end-user can customize to his/her exact requirements.
- q **Easy to use.** ICX features are easily selected via on-screen menus, tool bars, and programmable keys, without the need to consult a user guide.
- q **Online help.** An easy-to-search help facility is available that describes all PC Phone features.
- q **Directory.** An unlimited database of contacts that can be searched by name, address, etc., allowing easy dealing of internal or external calls.
- q **Caller ID.** End-users can identify incoming callers by the number they're calling from (if the CO supports Caller ID functionality).
- q **Call logging.** The PC Phone can record and report every incoming and outgoing call with time, date, duration, calling/called name from directory, etc.

System Requirements for PC Phone

- CPC-96, CPC-288, or ICX (all versions)
- an 80486 or compatible processor, running at 33 MHz or higher
- 8MB of RAM
- 1.44MB (3-1/2") floppy disk drive
- Microsoft Windows Version 3.1x (using Win 32s), Windows 95, or Windows NT Version 3.51
- Windows-compatible mouse
- 1 spare ISA expansion slot

PC Phone Connectivity

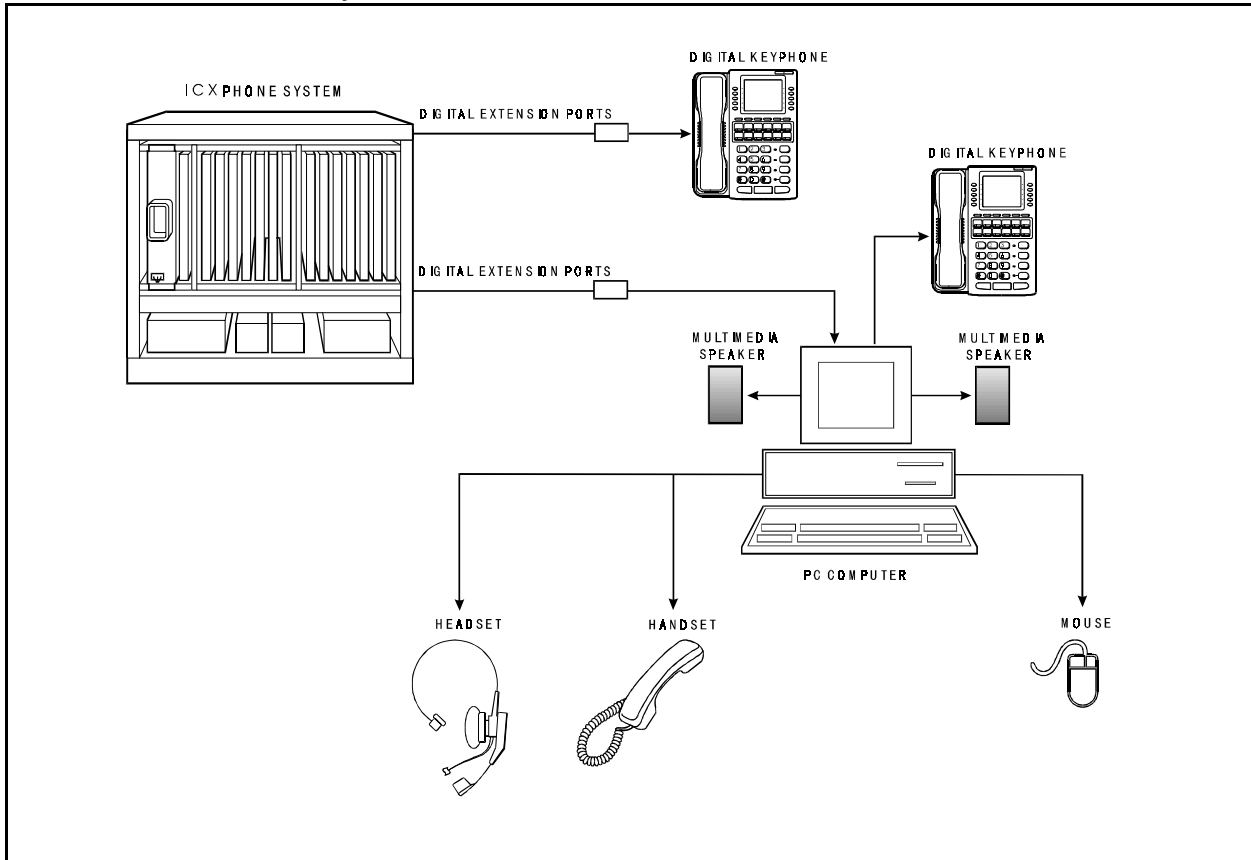

PC ATTENDANT CONSOLE

The **PC Attendant Console** is for the receptionist/operator position. It is designed to replace the DSS/72 console & keyphone combination that's commonly used as the Attendant.

This product is offered in two capacities: a **2-port solution** (equivalent to one 24-key phone with one DSS/72 console) which is capable of monitoring up to 96 ports; and a **6-port solution** (equivalent to one 24-key phone with five DSS/72 consoles) which supports a maximum of 384 ports.

In addition to providing all the features of a PC Phone, the PC Attendant Console will also offer:

- q **Flexible, scalable Busy Lamp Field (BLF)**. One Console can display up to 384 BLFs.

- q **Line prioritization.** The PC Attendant Console can assign priorities to incoming calls independent and separate from ICX priorities.
- q **Reporting.** The PC Attendant Console can produce graphical and text reports on system and operator performance.

**System Requirements for PC Attendant Console/96
(same as PC Phone)**

- CPC-96, CPC-288, or CPC-576 (all versions)
- an 80486 or compatible processor, running at 33 MHz or higher
- 8MB of RAM
- 1.44MB (3-1/2") floppy disk drive
- Microsoft Windows Version 3.1x (using Win 32s), Windows 95, or Windows NT Version 3.51
- Windows-compatible mouse
- 1 spare ISA expansion slot

System Requirements for PC Attendant Console/384

- CPC-96, CPC-288, or CPC-576 (all versions)
- an 80486 or compatible processor, running at 33 MHz or higher
- 8MB of RAM
- 1.44MB (3-1/2") floppy disk drive
- Microsoft Windows Version 3.1x (using Win 32s), Windows 95, or Windows NT Version 3.51
- Windows-compatible mouse
- 3 spare ISA expansion slots

PC Attendant Console Connectivity

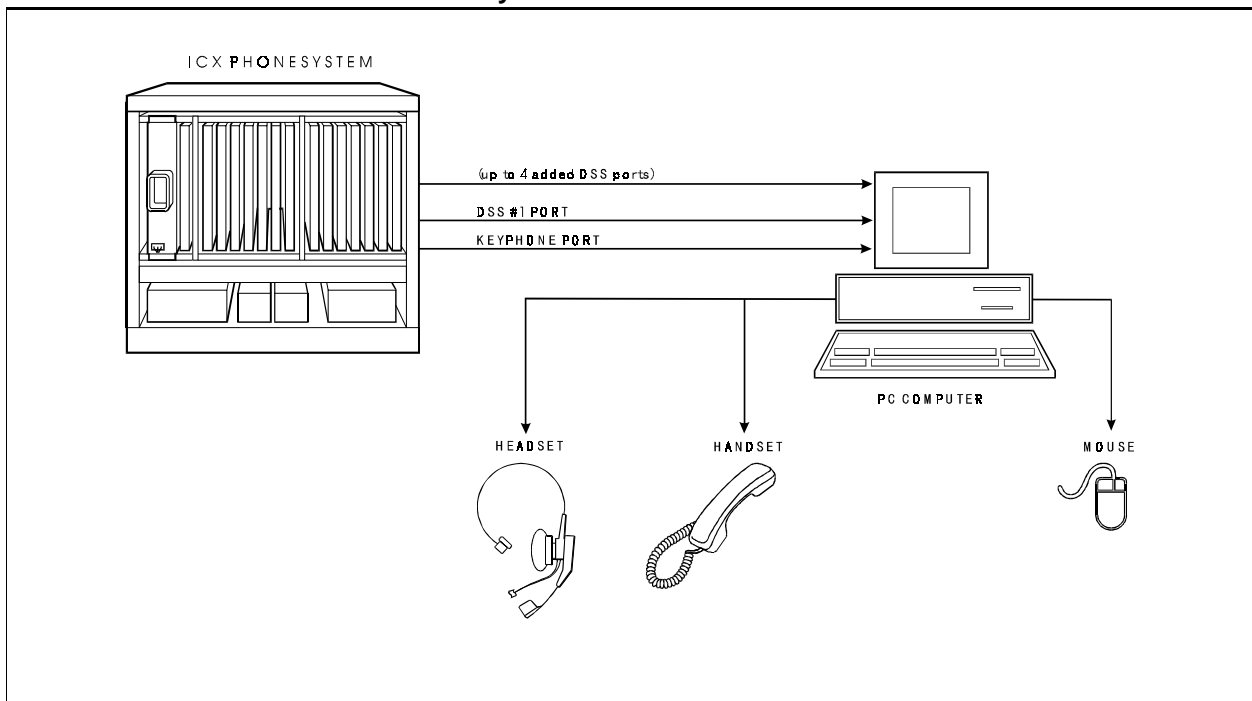

VOICE MAIL

With the ICX, Voice Mail can either be built-in (installed and programmed internally) or built-out (a third-party application hooked up to the phone system). Both are explained below.

BUILT-IN VOICE MAIL WITH 2-WAY CALL RECORDING

The ICX's Built-In Voice Mail option provides simplified Voice Mail functionality. Hardware for this option is installed inside the ICX cabinet, and it is customized in system programming.

Each Built-In Voice Mail system supports up to 248 private extension mailboxes, plus another 6 for general use. Up to 16 users can simultaneously access a single Voice Mail system. A multiple-cabinet system can support up to 4 Voice Mail systems (minimum 4-cabinet configuration).

These are some of the functions of Built-In Voice Mail:

- q Extensions can be automatically assigned mailboxes (the mailbox number is the same as the extension number).
- q General-use mailboxes can be set up.
- q Basic functions of Auto Attendant and backup call answering can be programmed.
- q Messages can be "broadcast" (copied) to multiple extensions.
- q Calls can be evenly distributed to different mailboxes during auto-answer mode.
- q 2-way call recording can be performed. A recording can be either automatically or manually stored as a message in any mailbox.
- q 1-digit intercom dealing can be used during Voice Mail service (for example, the caller wants to transfer himself to another extension after leaving a message).
- q Automatic notification of a mailbox message to an outside pager or phone number can be programmed.

Specifications for Built-In Voice Mail:

Maximum Number of Mailboxes: 254

Maximum Message Storage Time: 40 hours

AUTOMATIC CALL DISTRIBUTION (ACD)

ACD provides efficient presentation, handling, and management of incoming calls for phone systems that experience heavy call traffic. Calls can be evenly (or fairly) distributed to different groups of specialized users, called "agents." And call traffic data can be sent to a PC computer or printer through the ICX's RS232C serial port.

BUILT-IN ACD

Panasonic's Built-In ACD offers low-cost, easy installation, programming, and operation of ACD functionality. Some of the strong points of this product are:

- q **One-vendor solution.** There is only one place you have to call - Panasonic - to support and service your ACD. Saves time and eliminates miscommunication.

- q **Easy installation.** This is a card-type product. All you have to do is insert the unit into the ICX cabinet, and enter a few program settings for it. You don't need to wire any cable or install any awkward, extra equipment.
- q **Simple operation.** Agents can use our Large-LCD phones to handle calls efficiently. Agent features can be performed simply by following the prompts displayed on the LCD.
- q **Easy programming and flexibility.** Use a Large-LCD phone to enter the DBS 576 programming mode, and go to one area of settings specifically for ACD. No special equipment or complicated programming is required.
- q **Powerful ACD functionality.** Incoming calls can be routed to the first available agent, or transferred to Voice Mail. Supervisors can instantly access the current status of all agents. MIS reports can be generated.

Specifications for Built-In Voice Mail:

Maximum no. of ACD Units per System: 2 (in a 2+ cabinet configuration)

Agent Groups per ACD Unit: 2

Agent IDs per Group: 32

Maximum Agent IDs per ACD Unit: 50

Number of Agents Simultaneously Logged In: 32

Supervisor IDs per Group: 1

Supervisor IDs per ACD Unit: 2

Voice Ports per Group: 4

Voice Ports per ACD Unit: 4

Music Ports: 1 (on main unit/external MOH source)

MIS Monitor Ports: 1 (RS232C 9600bps)

Number of Recording Messages: 6 (maximum 14 seconds per message)

Fixed Message: 5 minutes

CHAPTER 6 - SPECIFICATIONS

OVERVIEW

This chapter provides a detailed lists of all system specifications in an easy-to-follow table format.

Note: The following specifications are subject to change without notice.

Electrical Characteristics

Input Power

Equipment	Power Requirements
All ICX Cabinets	100-240V AC \pm 10% 60 Hz
ICX key telephones	3 watts maximum (powered from the ICX)

Power Consumption and Heat Generation

System Status	1 Cabinet	2 Cabinets	3 Cabinets	4 Cabinets	5 Cabinets	6 Cabinets
Power Requirements (Watts)						
Maximum Traffic	TBD	TBD	TBD	TBD	TBD	TBD
Heat Generation (Btu per hour)						
Maximum Traffic	TBD	TBD	TBD	TBD	TBD	TBD

Environmental Requirements

Battery Backup Capacity

System	Battery Pack	Capacity (with maximum traffic)
ICX	VB-44025	30 minutes

Temperature and Humidity Requirements for System Operation (excluding Built-In Voice Mail)

Environmental Conditions	Requirements
Temperature	32 to 104 degrees F (0 to 40 degrees C)
Relative Humidity	30 to 90%

Temperature and Humidity Requirements for Built-In Voice Mail Operation

Environmental Conditions	Requirements
Temperature	41 to 95 degrees F (5 to 35 degrees C)
Relative Humidity	30 to 90%

Dimensions and Weight for Single-Cabinet Systems and Telephones

	Base Cabinet	Expansion Cabinet
Dimensions (H x W x D in inches)		
Cabinet	26 3/4" W x 10 7/8" D x 20 5/16" H (including top panel)	26 3/4" W x 10 7/8" D x 17 2/16" H (not including top panel)
VB-44225	4 1/8 x 7 3/8 x 9	
Other key telephones	3 3/4 x 7 3/8 x 9	
DSL T	3 1/8 x 7 3/8 x 9 1/8	
DSS/72	2 15/16 x 4 13/16 x 9 3/16	
EM/24	2 15/16 x 2 3/8 x 9 3/16	
Weight (lbs)		
Cabinet	Approximately 44	Approximately 44
VB-44225	2.3	
Other key telephones	2.2	
DSL T	1.6	
DSS/72	1.2	
EM/24	.95	

Resource Maximums

System Resources	1 Cabinet	2 Cabinets	3 Cabinets	4 Cabinets	5 Cabinets	6 Cabinets
CO line ports	96	192	288	384	480	576
Station ports	96	192	288	384	480	576
CO line/Station Speech path switching	nonblocking					

Feature Related Capacities

Resource	Maximum for					
	1 Cabinet	2 Cabinets	3 Cabinets	4 Cabinets	5 Cabinets	6 Cabinets
CPU configuration	CPC-96	-----	-----	-----	-----	-----
	CPC-288			-----	-----	-----
	CPC-576					
Cabinet connection	-----	1	2	3	4	5
Loop Start	96	192	288	384	480	576
ISDN BRI	48	96	144	192	240	288
ISDN PRI(8/16/24)	3	6	9	12	15	18
Analog Ext.	96	192	288	384	480	576
Digital Ext.	96	192	288	384	480	576
ISDN BRI	48	96	144	192	240	288
ISDN PRI	3	6	9	12	15	18
EM 24	96	192	288	384	480	576
DSS	12	24	36	48	60	72
3 Member Conf. x 8	1	1	1	1	1	1
8 Member Conf. x 1	1	2	3	4	5	6
DTMFR Unit	1	2	3	4	5	6
API Unit	1	1	1	1	1	1

Resource	Maximum for					
	1 Cabinet	2 Cabinets	3 Cabinets	4 Cabinets	5 Cabinets	6 Cabinets
ACD Unit	1	1	1	2	2	2
VM/AA Unit	1	2	3	4	4	4
Traffic Condition	6 OHCS					
Speech Pass	Time division PCM method					
MCO Tenant	12	24	36	48	60	72
MCO Trunk Group	99	99	99	99	99	99
Max. System Speed Dial	800	800	800	800	800	800
Max. Personal Speed Dial	20	20	20	20	20	20
Max. Digits of Speed Dial	24	24	24	24	24	24
Max. Name Digits of SPD	16	16	16	16	16	16
Max. Name Digits of PSD	7	7	7	7	7	7
Max. Name Digits of TRK	10	10	10	10	10	10
Max. Name Digits of EXT.	10	10	10	10	10	10
Attendant Group	1	1	1	1	1	1
Max. Attendant Member	20	20	20	20	20	20
Max. Hunting Group	12	24	36	48	60	72
Max. Hunting Member	20	20	20	20	20	20
External Page port	1	1	1	1	1	1
External Relay Control Port	5	5	5	5	5	5
Message Waiting Set (High) (Per Extension)	1	1	1	1	1	1
Message waiting set (Normal) (Per Extension)	4	4	4	4	4	4
Max Hot Line Setting	20	20	20	20	20	20
Floating	96	192	288	384	480	576
Ext. Class Of Service Group	16	16	16	16	16	16
Trk. Class Of Service Group	16	16	16	16	16	16
TRS Class	50	50	50	50	50	50
TRS/LCR 10/Leading Dial	100	100	100	100	100	100
Table TRS/LCR 8 digits Following Digits	500	500	500	500	500	500
LCR Time Pattern	4	4	4	4	4	4
LCR Time List (Per Time Pat.)	50	50	50	50	50	50
LCR Route List	100	100	100	100	100	100
LCR Dial Modification Pattern	50	50	50	50	50	50
Authorization ID	5	5	5	5	5	5
ISDN S point DID Table	200	200	200	200	200	200
Account Code Max. Digits	10	10	10	10	10	10
Verified Account Number	500	500	500	500	500	500
Verified Account Max. Digits	4	4	4	4	4	4
Pickup Group	10	10	10	10	10	10
Max. Paging Group	99	99	99	99	99	99
Max. Paging Member	72	72	72	72	72	72

Hardware Maximums

Type	Item	Name (Abbreviated name)	Model No.	External dimensions (approximate mm)			Weight (approximate kg)	Supply voltage (V)	Maximum power dissipation (W) Current (A)
				W	H	D			
Main Cabinet	40 ports Main Cabinet	CAB40	VB-44010	405	495	260	13		205W 2.3A
	96 ports Main Cabinet	CAB96	VB-44020	680	515	260	20		380W 4.3A
	96 ports Expand Main Cabinet	CAB96B	VB-44021	680	455	260	20		
Power supply	Switch Box	SWBOX	VB-44023	163 145	66 59	121 130	0.8		1.0A
Control	CPC-M Card	CPC96	VB-44410	26	250	178	0.5	+5 +24	600mA 10mA
	CPC-L Card	CPC288	VB-444201	26	250	178	0.5	+5 +24	800mA 10mA
	CPC-LL Card	CPC576	VB-444301	26	250	178	0.5	+5 +24	1500mA 10mA
	Connection Cable Card-M	CBLMST	VB-444501	26	250	178	0.5	+5	100mA
	Connection Cable Card-S	CBLSLV	VB-444502	26	250	178	0.5	+5	350mA
	Connection Cable Kit	CBLKIT	VB-44450				0.5	+5	350mA
	Building Block Card	CBL	VB-44451	26	250	178	0.5	+5	350mA
	Connection Cable Card- DBS	CBLDBS	VB-44452	26	250	178	0.5	+5	350mA
	Service Control Card	SCC	VB-44181	26	250	178	0.5	+5 +24	80mA 25mA
	Time Switch Card /L	TSW288	VB-444202	26	250	178	0.5	+5	885mA
Time Switch Card /LL	TSW576	VB-444302	26	250	178	0.5	+5	910mA	
Trunks	Loop Start Trunk Card	LTRK/8	VB-44510	26	250	178	0.5	+5 +24	0.5W 2W
	BRI Card	TBRI/4	VB-44530	26	250	178	0.5	+5 +24	150mA 130mA
	PRI Card	PRI/23	VB-44540	26	250	178	0.5	+5 +24	100mA 120mA
	DID Trunk Card	DIDTR8	VB-44520	26	250	178	0.5		
	E&M Card	E&M	VB-44560	26	250	178	0.5		

Type	Item	Name (Abbreviated name)	Model No.	External dimensions (approximate mm)			Weight (approximate kg)	Supply voltage (V)	Maximum power dissipation (W) Current (A)
				W	H	D			
Extension lines	Digital Extension Card	DEC/8	VB-44610	26	250	178	0.4	+5 +24	100mA 1.6mA
	Analog Extension Card	AEC/8	VB-44620	26	250	178		+5 +24	500W 12W
	BRI Unit (S-Point)	SBRI/4	VB-44630	26	250	178	0.5	+5 +24	150mA 130mA
	PRI Card	PRI/30	VB-44540	26	250	178	0.5	+5 +24	100mA 120mA
Options	8 DTMF Receiver Card	MFR/8	VB-44110	26	250	178	0.5	+5	110mA
	Conference Card	CONF	VB-44120	26	250	178	0.5	+5	100mA
Audio applications	ACD Card	ACD	VB-44140	26	250	178	0.5	+5	150mA
	8 Voice Processing Card	VPU/8	VB-44150	26	250	178	0.5	+5	700mA
	4 Voice Processing Card	VPU/4	VB-44160	26	250	178	0.5	+5	350mA
	Voice Storage Service Card	VSSC	VB-44170	47	250	178	1.0	+5	2.2A
	HDD for replacement	VSSCHD	VB-44171	90	122	23	0.2	+5	2.7W 1.3A
On-card packages	Sync Package/Network Unit	SYNC	VB-44460	70	70	1.6	0.1	+5	50mA
	Remote Administration Unit	RAI	VB-44182	70	70	1.6	0.1	+5	50mA
	PC Card 96	PCCM1	VB-44410A						
	PC Card 288	PCCL1	VB-444201A						
	PC Card 576	PCCLL1	VB-44431						

Type	Item	Name (Abbreviated name)	Model No.	External dimensions (approximate mm)			Weight (approximate kg)	Supply voltage (V)	Maximum power dissipation (W) Current (A)
				W	H	D			
Phone systems	Key Telephone (12key-SPU)	12CO/STD	VB-44220	186	90	233	1	+27	2.7W
	Key Telephone (12key-LCD/SPU)	12CO/D/SPU	VB-44223	186	90	233	1	+27	2.7W
	Key Telephone (12key-LLCD/SPU)	12CO/LD/SPU	VB-44225	186	90	233	1	+27	2.7W
	Key Telephone (12key-LCD/Soft key/Voice/SLT/SPU)	12CO/D/SK/VR/SLT/SPU	VB-44224	186	90	233	1	+27	2.7W
	Key Telephone (24key-LCD/SPU)	24CO/D/SPU	VB-44233	186	90	233	1	+27	2.7W
	Digital Single Line Telephone	D-SLT	VB-41200	186	90	233	1	+27	2.7W
	DSS	DSS	VB-44320	123	74	233	0.5	+27	3.3W
	EM24	EM24	VB-44310	60	74	233	0.5	+27	1.1W
	Voice Recognition Adapter	VRADP	VB-44101	163	73	178	0.5	+5 +27	3.6W 3.6W
External optional equipment	Doorphone Adapter	DPH-ADP	VB-3473						
	Doorphone	DPH	VL-568GPEX, VL-582APEX						
	Power Failure Unit	PFU	VB-43703	120	240	45	0.4	+24	
Battery	Battery	BATT96	VB-44025						
Miscellaneous	Connection Metal Kit	MTLKIT	VB-44024						