

PRICE \$3.00



**Assembling
and Using Your...**

Heathkit

**"SENECA" AMATEUR
TRANSMITTER**

MODEL VHF-1

HEATH COMPANY

A Subsidiary of Daystrom Inc.

BENTON HARBOR, MICHIGAN

595-212

ASSEMBLY AND OPERATION OF THE HEATHKIT "SENECA" AMATEUR TRANSMITTER MODEL VHF-1



SPECIFICATIONS

Power Input:.....	6 meters 140 watts CW, 120 watts Phone (peak) 2 meters 110 watts CW, 95 watts Phone (peak)
Output Impedance:.....	50-72 Ω (non-reactive)
Output Coupling:.....	Link (coaxial)
Operation:.....	Crystal-VFO, CW-Phone
Band Coverage:.....	50-54 MC, 144-148.3 MC
Audio:.....	Screen modulated, controlled carrier
Tube Complement:.....	5R4GY HV rectifier 5V4G LV rectifier OA2 voltage regulator 12AX7 speech amplifier 6DE7 modulator, carrier control 6AU6 VFO 6AN8 crystal oscillator-multiplier 2E26 driver 2-6146 push-pull power amplifier 6AQ5 clamp
Power Requirements:.....	117 volts AC, 60 cycles
Standby (phone, CW):.....	120 watts
Full load (phone, CW):.....	400 watts (intermittent)
Cabinet Size:.....	16 5/8" wide x 10 1/8" high x 10" deep
Net Weight:.....	50 lbs.
Shipping Weight:.....	62 lbs.

INTRODUCTION

The Heathkit Model VHF-1 "Seneca" Transmitter was designed to extend the transmitting complement of the amateur radio station into the VHF region. It features up to 120 watts input on phone and 140 watts input on CW in the 6-meter band. In the 2-meter band, these ratings are reduced slightly to prolong final amplifier tube life. It includes controlled carrier phone operation, has built-in VFO for both 6 and 2 meters, and four switch-selected crystal positions. Panel controls allow VFO or crystal control, phone or CW operation on both amateur bands.

The "Seneca" consists of two power supplies, five radio frequency stages, and two dual-triode audio stages. A pair of 6146's, operating push-pull in the final amplifier, uses quarter wave tuned lines or a split-tank inductor, with a tunable link output coupling for 50 or 72 Ω transmission line.

Complete RF shielding from the VFO circuit to the final amplifier is incorporated in this Transmitter. Feed-through type bypass capacitors are used on all power leads entering the RF compartments for greater TVI protection and transmitter stability.

The front panel controls consist of an Xtal-VFO switch, meter switch, two antenna loading controls (antenna tuning and antenna coupling), buffer tuning, multiplier tuning, driver tuning, final amplifier tuning, function switch, band switch, VFO tuning, and a spotting push button switch. The VFO slide rule type dial is edge illuminated and with vernier tuning provides ample bandspread and accurate frequency settings.

The mike connector, output connector, key jack, and auxiliary socket are located on the rear chassis apron. The auxiliary socket is so connected to allow remote control of the Transmitter such as using voice control with a Heathkit Voice Control Unit, and also has connections for receiver muting and for operating an antenna relay.

The following block diagram and circuit description will give the builder a better understanding of the Transmitter. This knowledge is an invaluable aid to construction and as such, is well worth reading thoroughly.

IN A TRANSMITTER OF THIS SIZE, LETHAL VOLTAGES ARE PRESENT. CONSEQUENTLY, GREAT CARE MUST BE EXERCISED WHEN ANY TESTS OR ADJUSTMENTS ARE MADE.

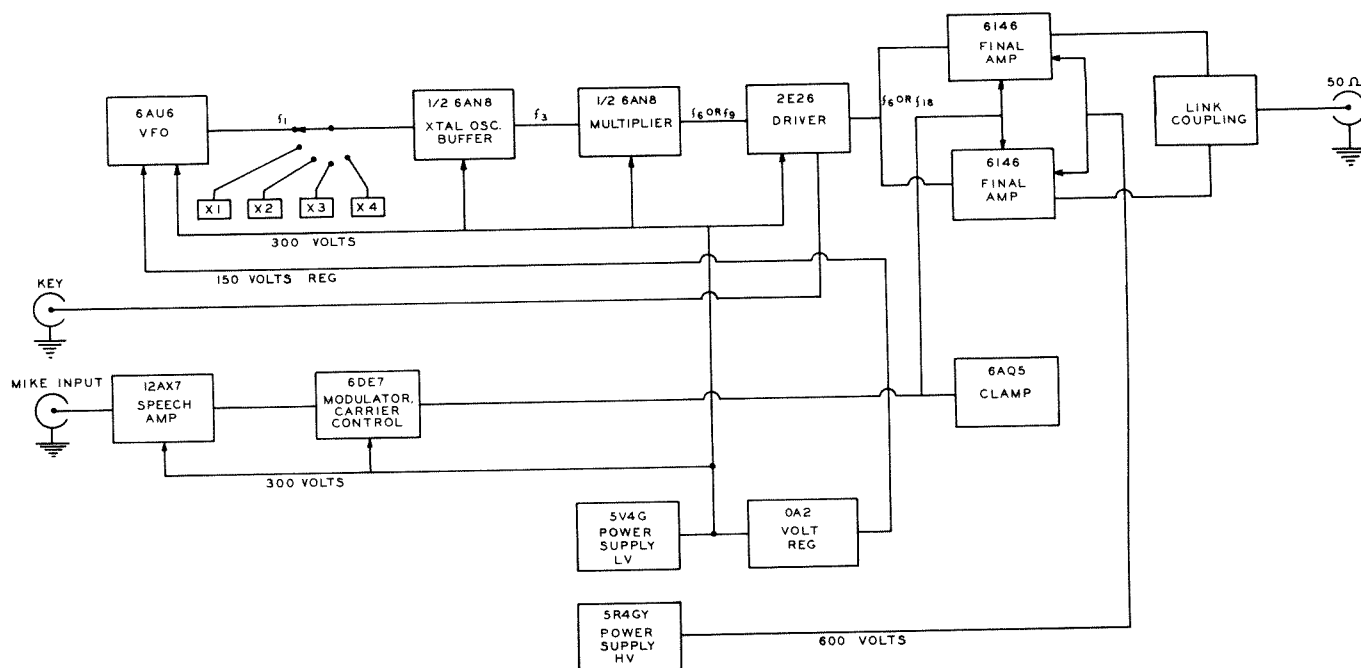

Figure 1

VFO

The VFO circuit consists of a 6AU6 tube operating as a Clapp oscillator in the frequency ranges of 8.000 to 8.222 mc and 8.333 to 9.000 mc. Undue heating effects are prevented by mounting the tube on top and outside of the VFO enclosure. Also, the VFO subchassis is located away from all other heat generating components in the final assembly to further decrease heating effects upon the enclosure. A double bearing ceramic insulated dual tuning capacitor is used as the frequency control. The dual capacitor, consisting of two stator assemblies of different capacity, permits a large bandspread on both bands. Two ceramic insulated air trimmers for bandspread adjustment prevent initial drift during calibration.

The VFO frequency determining coil (L-1) is wound on a heavy ceramic slug-tuned form, heavily doped and baked. This combination achieves high-Q, low drift, and decreases the effect of humidity. A temperature compensating capacitor (C-1) of the negative type is mounted in close proximity to the coil. Thus, a rise in temperature of the coil will increase the inductance, and this same temperature rise will decrease the capacity of the temperature compensating capacitor. By properly proportioning these components, the effects of one cancel the other and the frequency remains constant with a change in temperature.

The VFO switch has solid coin silver contacts for minimum of contact resistance and long life. It is operated by a linkage mechanism on the band switch, which correlates the VFO output frequency with the band in use.

The Clapp or series-tuned Colpitts oscillator circuit is a high-Q circuit obtained by tapping the tube across only a small portion of the oscillating tank circuit, resulting in very loose coupling between tube and circuit. Three capacitors connected in series across the coil (consisting of the two large fixed value capacitors (C-3, C-4) and the tuning capacitor with their respective padding capacitors in parallel) provide the taps across which the tube is connected. These large capacitances also lessen the effect of input tube capacitance upon frequency. The 6AU6 tube essentially operates as an electron-coupled oscillator with the tube's screen grid as the oscillator plate. The screen grid voltage is stabilized at 150 volts by an OA2 regulator in the power supply. With the screen grid operating as the oscillator plate, the actual tube plate is coupled to the oscillator only by the electron stream in the tube and is further shielded from the oscillator by the grounded suppressor grid. This effectively isolates the oscillator circuit from the following stages and lessens the effect of loading on the VFO frequency.

The output of the VFO is also band switched between two slug-tuned coils (L-2 and L-3), tuned with the distributed capacity of the coaxial cable which is fed to one position of the Xtal-VFO switch in the multiplier subchassis. A 47 Ω resistor (R-2), in series with the output coils, broadens the circuit and therefore the RF output voltage from one end to the other of both bands is fairly constant in amplitude.

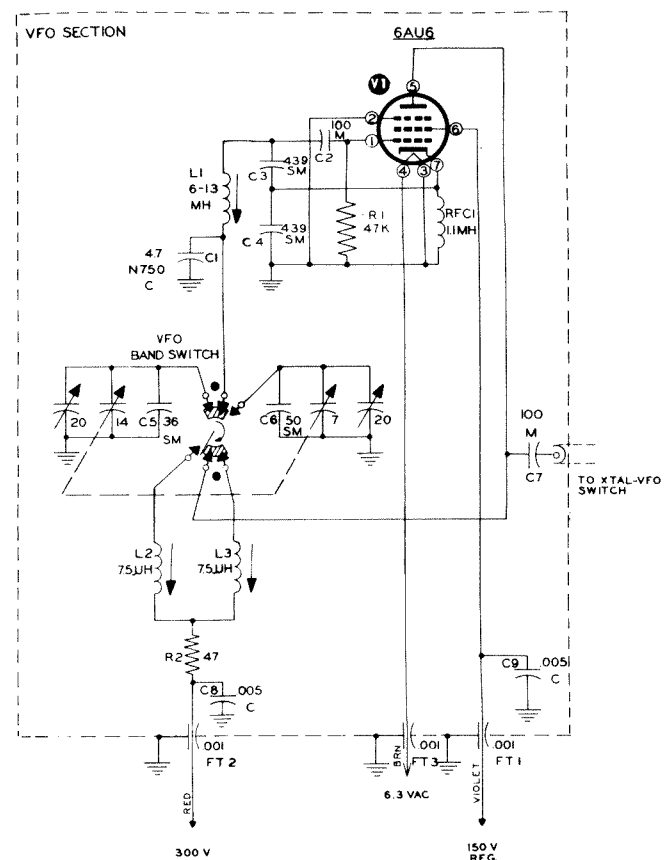

Figure 2

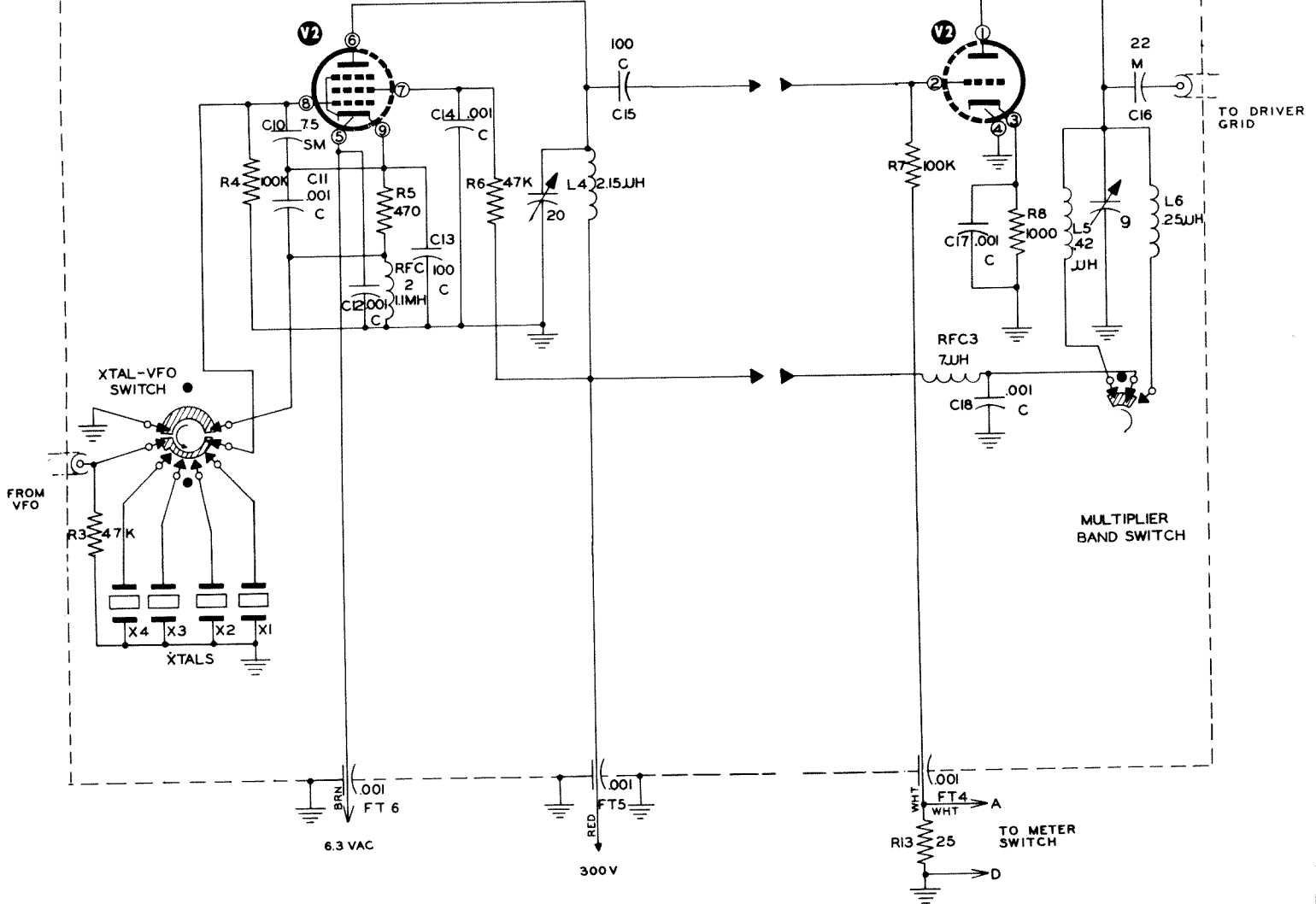

Figure 3

Figure 4

CRYSTAL OSCILLATOR-BUFFER

The pentode section of a 6AN8 is operated in a tuned-plate circuit, the oscillating circuit being equivalent to a grounded-plate Colpitts, with the crystals connected between grid and ground. A 7.5 mmf capacitor (C-10) connected between grid and cathode increases excitation and prevents sluggish crystal operation. Four crystals may be switched into the circuit by means of the Xtal-VFO switch. In the VFO position, the output of the VFO is connected between grid and ground and the cathode RF choke (RFC-2) is short circuited in this position. A 470 Ω resistor (R-5) in the cathode circuit provides self-bias to prevent exceeding plate dissipation with loss of excitation. The plate circuit is tuned to three times the input frequency with an air wound high-Q coil (L-4) and a 20 mmf variable capacitor. The capacitor is brought out to the front panel for tuning this stage from 24 mc to 27 mc. The output is capacity coupled to the triode section of the 6AN8.

MULTIPLIER

The triode section of the 6AN8 operates as a doubler to the 6-meter band and as a tripler for the 2-meter band. A meter shunt resistor (R-13) is permanently connected in the grid circuit of this stage and the meter switched across it when reading drive from the crystal oscillator-buffer stage.

This stage also has self-bias, using a $1\text{ K}\Omega$ resistor (R-8) in the cathode circuit. The multiplier switch, which is operated by a linkage mechanism on the band switch, switches the B+ voltage for the plate circuit between two tank coils. With the multiplier switch in the 6-meter position, a 15 mmf variable capacitor, which is brought out to the front panel, tunes the 6-meter tank coil (L-5) from 50 mc to 54 mc . In the 2-meter position, the same 15 mmf variable capacitor tunes the 2-meter tank coil (L-6) from 72 mc to 74.15 mc . An RF choke (RFC-3), in series with the tank coils, prevents RF from feeding back into the B+ line. The output of this stage is capacity coupled to the driver stage through a coaxial cable. Both the crystal oscillator-buffer and second multiplier circuits are completely enclosed for shielding and all leads entering the subchassis assembly are bypassed with feed-through type capacitors.

DRIVER

A 2E26 operates straight through on six meters, and doubles to two meters to drive the final amplifier. As in the preceding stage, grid drive is measured and the stage is self-biased. Cathode keying is employed with the cathode circuit being connected to the key jack. It is also connected to the spotting push button switch and the function switch. Closing the key, depressing the spotting push button switch, or placing the function switch in phone position all complete the cathode circuit to ground to put the stage into operation.

Due to the fact that the driver operates straight through on 6 meters, more than ample drive is provided so it is necessary to reduce this drive to prevent damage to the grids of the final amplifier. This is accomplished by reducing the screen voltage to the 2E26 by means of a voltage divider network, consisting of a $23.5\text{ K}\Omega$ resistor (R-11) which is connected in series with a $10\text{ K}\Omega$ resistor (R-12) through the driver band switch. With the band switch in the 2-meter position, the $10\text{ K}\Omega$ resistor is disconnected and normal screen voltage is applied for maximum output from this stage. By properly proportioning the two values of screen voltages, the drive appearing at the grids of the final amplifier will be approximately the same on both bands.

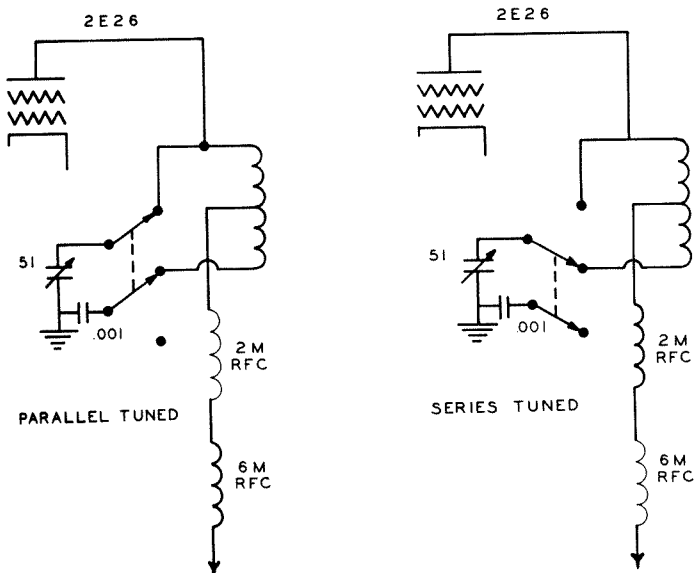
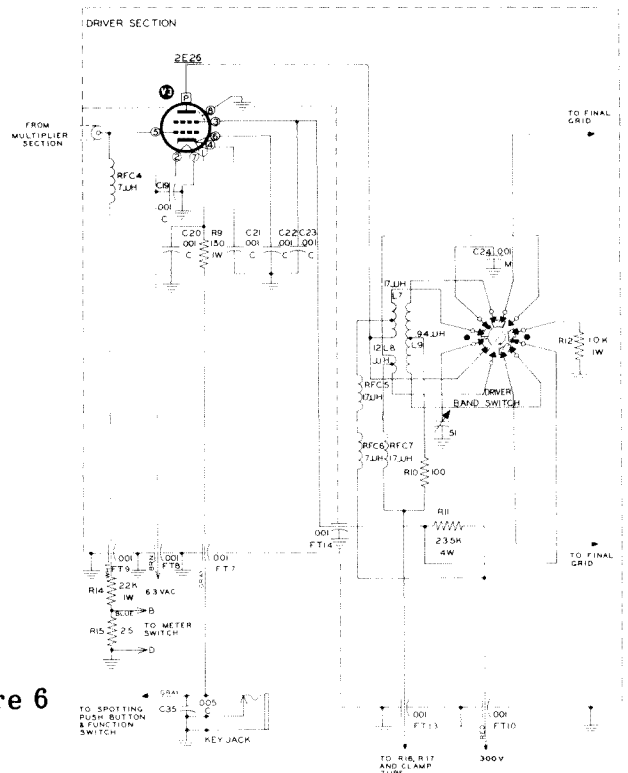

Figure 5

Figure 6



Referring to Figure 5, the plate circuit of the 2E26 is switched from a "parallel tuned" tank circuit on 6 meters to a "series tuned" tank circuit on 2 meters. A 51 mmf variable capacitor tunes this circuit from 50 to 54 mc in the 6-meter band and 144 to 148.3 mc in the 2-meter band.

A 2-meter RF choke (RFC-5) which is connected to the tank coil offers high impedance to the 2-meter energy and a 6-meter RF choke (RFC-6) connected in series with the 2-meter RF choke offers high impedance to the 6-meter energy.

The output of the driver stage is transformer coupled to the grids of the final amplifier tubes. This stage is also completely shielded, using feed-through type capacitors for all leads entering the compartment.

FINAL AMPLIFIER

Two 6146 type tubes operate in push-pull in the final amplifier stage which operates straight through on both bands.

The grid circuits are switched between two grid tank coils, one which is tuned to 6 meters (L-9) and the other which is tuned to 2 meters (L-8), using the input capacities of the final tubes. Both coils are mounted on the driver band switch wafer using inductive coupling for maximum energy transfer from the driver stage. In addition, these double tuned circuits help to reject high order oscillator and multiplier harmonics.

Neutralization is employed on both bands for maximum stability of the final amplifiers. The self-neutralizing frequency of the 6146 is in the neighborhood of 100 mc, making a switched neutralization circuit mandatory. With the band switch in the 6-meter position, conventional cross-neutralization is employed, but with the band switch in the 2-meter position, neutralization is accomplished by increasing the effective grid-to-plate capacitance of each tube in order to cancel the screen-lead inductance. With the 6146's operating in the 2-meter band, the screen-lead inductance becomes quite appreciable, allowing a considerable amount of energy leak-through from plate to grid even though the screen is carefully bypassed. Screen neutralization could have been employed, but because of its frequency sensitivity, another operating control would be required.

The final amplifier tubes are protected by clamp action, using a 6AQ5 as a clamp tube. With the function switch in the CW position, the screen voltage to the 6146's is obtained through a dropping resistor (R-32) from the high voltage plate supply and the 6AQ5 tube plate is connected at the 6146 screens. The 6AQ5 cathode is grounded and its grid is common to the grid circuits of the 6146 stage. As long as grid excitation is obtained from the driver stage, the bias voltage developed keeps the clamp tube cut off and it does not draw current. If excitation to the final tubes is lost, the 6AQ5 grid voltage goes to zero and the tube draws heavy current, dropping the screen voltage to the 6146's to a very low value, thus keeping the final amplifiers well below the maximum plate dissipation. With the function switch in the phone position, the screen voltage is obtained from the cathode circuit of the 6DE7 carrier control tube and the 6AQ5 clamp tube action is the same as above.

The plate tank circuit of the final amplifier is enclosed in a separate compartment for complete shielding and to reduce radiation loss from the tuned lines. The plate circuit is composed of a shorted quarter-wave section of transmission line for the 2-meter band. A double ended

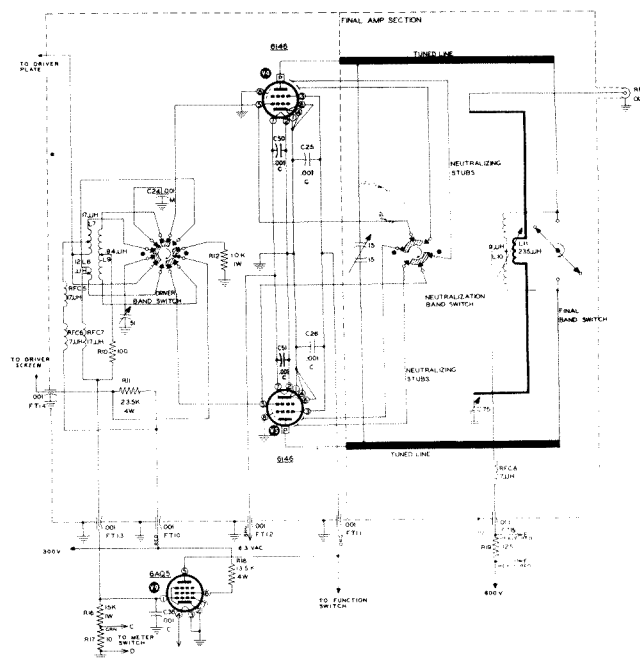

Figure 7

knife action type switch (final band switch) located at the ends of the silver plated tuned lines acts as the shorting bar and is connected to the band switch linkage mechanism. With the band switch in the 6-meter position, the tuned lines are unshorted and merely act as extended plate leads for the 6-meter split tank coil. The 6-meter tank coil also acts as a pair of 2-meter RF chokes connected at the low potential RF point on the tuned lines when operating on 2 meters. The tuned lines and the tank coil are resonated at the tube end by a "butterfly" type variable capacitor. The rotor of the "butterfly" capacitor is left ungrounded to prevent possible stray resonances and parasitic oscillations that may appear higher than the operating frequency.

Quarter-wave tuned lines were chosen over half-wave tuned systems because of the space limitations and also the fact that in push-pull circuits, the third order harmonic is prominent. Thus, a strong third harmonic of 50 megacycle energy from the final amplifier could result using a half-wave system.

Link coupling is used on both bands by the use of a dual purpose link. A one turn coil in the center of the hairpin loop couples into the center of the 6-meter tank coil, and the hairpin loop coupling to the end of the tuned lines. The RF output is fed to a coaxial jack on the rear apron of the Transmitter and a 75 mmf variable capacitor connected between the link and ground tunes out any reactance that may be present.

MODULATOR

A 12AX7 tube is used as a high gain two stage resistance coupled speech amplifier. The output of the speech amplifier is coupled to the 6DE7 through a low capacity coupling capacitor (C-30). This low capacity coupling, along with the 470 K resistor (R-27) and 100 mmf capacitor (C-31) which forms the feedback circuit from the modulator cathode back to the speech amplifier cathode, shapes the response to favor the voice frequencies, thus allowing a higher average level to be maintained where it will be the most effective.

The audio energy from the speech amplifier is coupled to the grid of one triode section of a 6DE7. This tube contains two dissimilar triode sections. One triode section is rated at 1.5 watts dissipation and the other at 7 watts dissipation. The lower rated triode is used as a direct coupled driver, its plate being tied to the control grid of the heavier duty triode which forms the modulator. This second triode is biased sufficiently to limit its conduction and therefore the screen voltage on the final is of a low value, which results in a low resting carrier.

With modulation the conduction of the heavy duty triode section is varied in accordance with the average voice level. This gives a controlled carrier effect by varying the screen voltage on the 6146 tubes, at the same time the audio signal is superimposed on this variable voltage. The net result is to produce a carrier output which increases with the percentage of modulation applied.

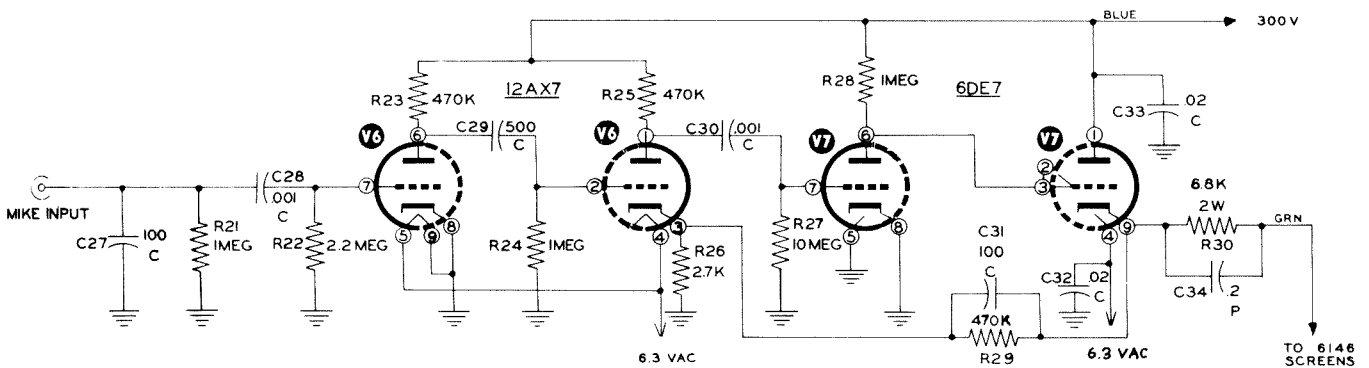

Figure 8

A single transformer is utilized for both the high voltage and low voltage power supplies. It also contains all of the filament windings.

The low voltage supply uses a 5V4G rectifier with a choke input filter which delivers 300 volts at 125 ma to the modulator and all RF sections, except the final amplifier.

The high voltage supply consists of a 5R4GY rectifier, choke input filter, two 125 mfd electrolytic capacitors in series, and a center-tapped bleeder resistor which also balances the series capacitors.

The two 125 mfd 450 volt electrolytic capacitors connected in series result in a filter capacity of 62.5 mfd at 900 volts, offering sufficient capacity for good dynamic regulation under varying load conditions and a good safety factor on voltage breakdown. The use of paper or oil capacitors becomes impractical at these values of capacity. The supply delivers 600 volts at 250 ma to the plates of the final amplifier.

Both sides of the AC line are fused in a special line plug and all circuits entering or leaving the transmitter chassis with 117 volts AC on them are bypassed with special AC line bypass capacitors.

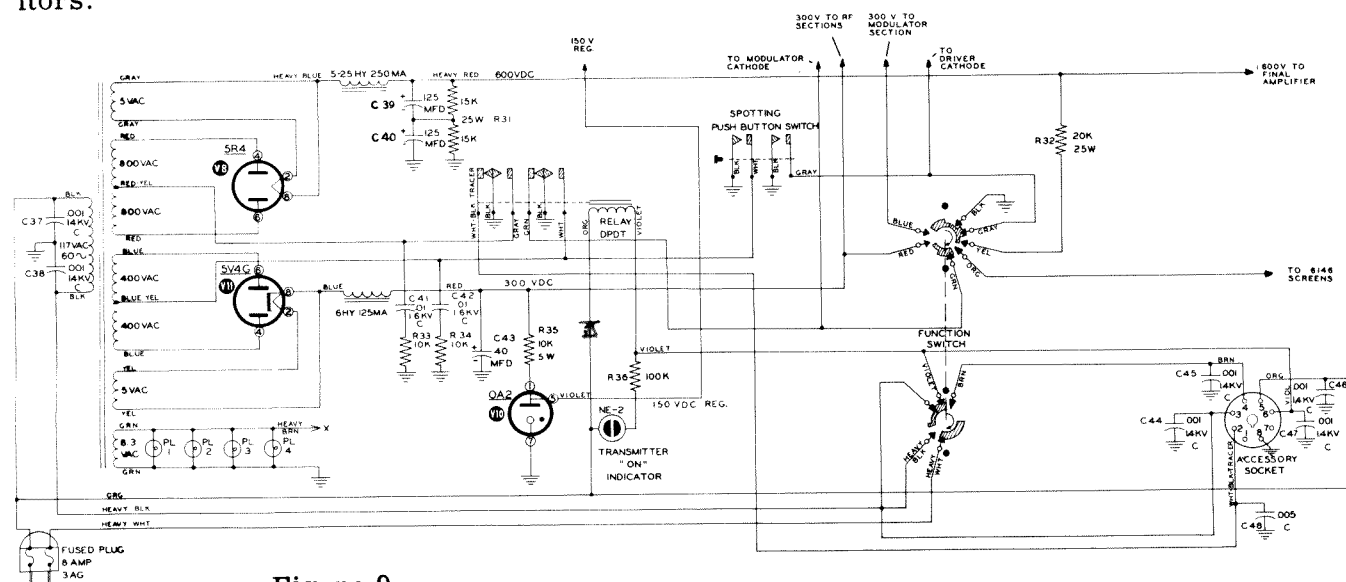

Figure 9

CONSTRUCTION NOTES

This manual is supplied to assist you in every way to complete your kit with the least possible chance for error. We suggest that you retain the manual in your files for future reference, both in the use of the Transmitter and for its maintenance.

UNPACK THE KIT CAREFULLY AND CHECK EACH PART AGAINST THE PARTS LIST. In so doing, you will become acquainted with the parts. Refer to the charts and other information shown on the inside covers of your manual to help you identify the components. If some shortage or parts damage is found in checking the Parts List, please read the REPLACEMENT section and supply the information called for therein, and include all inspection slips in your letter to us. Hardware items are counted by weight and there may be a few more or less than the quantity specified. If a few are missing, please obtain them locally if at all possible.

In order to expedite delivery to you, we are occasionally forced to make minor substitution of parts. Such substitutions are carefully checked before they are approved and parts supplied will work satisfactorily. In checking the Parts List for resistors, for example, you may find

that a resistor with a 5% tolerance has been substituted for a resistor with a 10% tolerance, as shown on the Parts List. These changes are self-evident and are mentioned here only to prevent confusion in checking the contents of your kit.

Resistors generally have a tolerance rating of 10% unless otherwise stated in the Parts List. Tolerances on capacitors are generally even greater. Limits of +100% and -50% are common for electrolytic capacitors.

PROPER SOLDERING TECHNIQUES

Only a small percentage of Heathkit purchasers find it necessary to return an instrument for factory service. Of these instruments, by far the largest proportion of malfunctions are due to poor or improper soldering.

Correctly soldered connections are essential if the performance engineered into a kit is to be fully realized. If you are a beginner with no experience in soldering, a half hour's practice with some odd lengths of wire may be a worthwhile investment.

For most wiring, a 30 to 100 watt iron or its equivalent in a soldering gun is very satisfactory. A lower wattage iron than this may not heat the connection enough to flow the solder smoothly over the joint. Keep the iron tip clean and bright by wiping it from time to time with a piece of steel wool or a cloth.

WIRING AND SOLDERING PROCEDURE

NOTE: ALL GUARANTEES ARE VOIDED AND WE WILL NOT REPAIR OR SERVICE INSTRUMENTS IN WHICH ACID CORE SOLDER OR PASTE FLUXES HAVE BEEN USED. WHEN IN DOUBT ABOUT SOLDER, IT IS RECOMMENDED THAT A NEW ROLL PLAINLY MARKED "ROSIN CORE RADIO SOLDER" BE PURCHASED.

1. Unless otherwise indicated, all wire used is insulated (hookup wire). If bare wire is to be covered with insulating sleeving, the instructions will state "Use sleeving".
2. Leads on resistors, capacitors and transformers are generally much longer than they need to be to make the indicated connection. In these cases, cut the lead off as specified in the step when connecting the part because in VHF equipment excessive lead length could impair operation.
3. Crimp or bend the lead (or leads) around the terminal to form a good joint without relying on solder for physical strength. If the wire is too large to allow bending, position the wire so that a good solder connection can still be made.

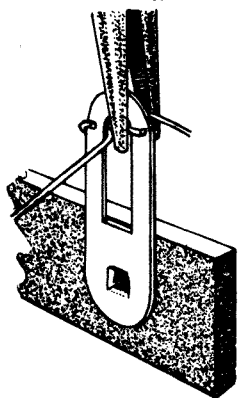

CRIMP WIRES

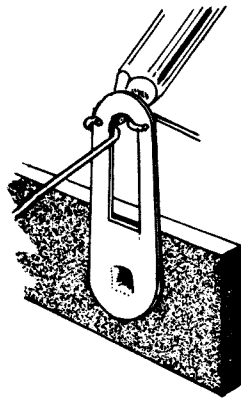

HEAT CONNECTION

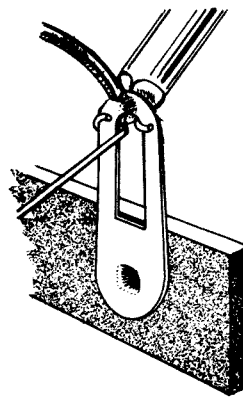

APPLY SOLDER

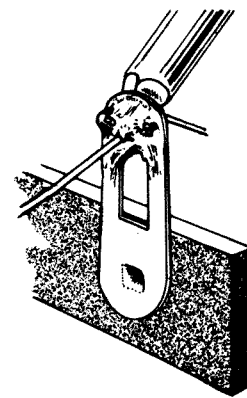

ALLOW SOLDER
TO FLOW

Mount the final amplifier housing on the chassis. Insert the eight spade bolts through the eight matching 5/32" holes in the chassis. Secure the housing, using #6 lockwashers under 6-32 nuts. Mount a 5-lug terminal strip on the protruding spade bolt at location DD, (see Pictorial 14 on page 38) using a #6 lock-washer under the mounting foot and under the nut.

- (✓) Loosen the two nuts holding the insulated tuning capacitor bracket in place and slide the bracket so that the "butterfly" capacitor shaft lines up with the insulated coupling. Push the insulated rod so that the coupling slips over the shaft and tighten the Allen setscrew.
- (✓) Locate the 5" long control shaft with two E grooves and a flat on one end of the shaft. Insert this end through the bottom shaft bushing in front of the housing and through the shaft bushing on the insulated bracket. Position the shaft until the two E grooves appear on each side of the two shaft bushings. Place E washers in each of the two grooves on the shaft.
- (✓) Tighten the two nuts holding the insulated tuning capacitor bracket in place, positioning the bracket so that the two shafts turn freely.
- (✓) Locate the slotted band switch linkage plate and start an 8-32 x 1/4" Allen setscrew in the hub. Place the linkage plate on the flat end of the shaft with the hub toward the insulated bracket. Position the slot over the driver band switch linkage plate, as shown in Detail 13. Rotate the shaft until the flat is in line with the setscrew, then tighten the setscrew.
- (✓) Bend the two bottom lugs 3 and 9 down at right angles on the neutralization band switch wafer. Cut the two top lugs off close to the ceramic wafer.
- (✓) Cut two lengths of #16 bare wire to 3 1/4" and two lengths to 2 7/8". Form the two long wires as shown in Detail 14A, and the two short wires as shown in Detail 14B.

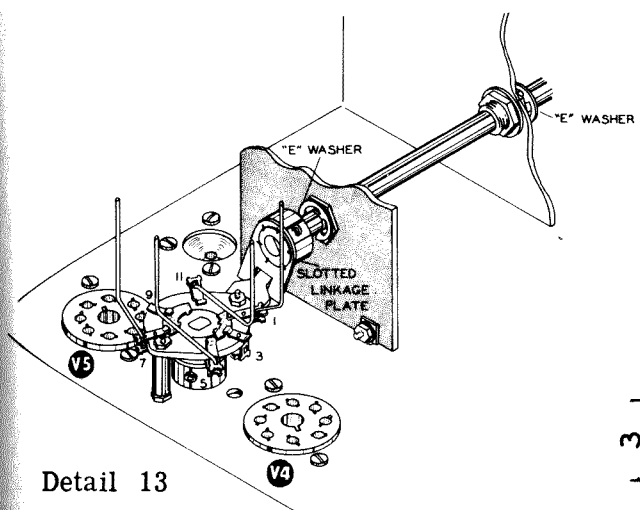

NEUTRALIZATION STUBS

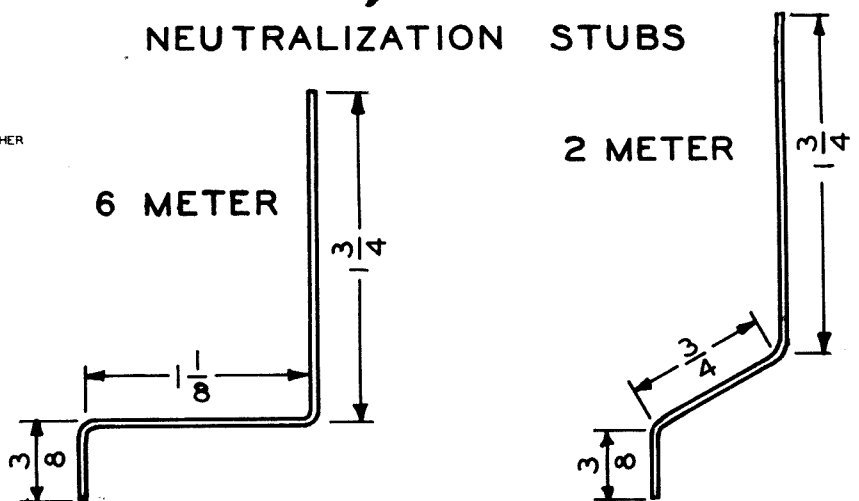

DETAIL 14A & B

- (✓) Mount the two 6-meter neutralizing stubs on the neutralization band switch at lugs 5 and 11. Insert the 3/8" end through both the top and bottom lugs, positioning the stubs as shown in Pictorial 13 and Detail 13, and solder in place.
- (✓) Repeat the above procedure for the 2-meter neutralizing stubs, except mount at lugs 1 and 7, as shown.
- (✓) Locate the two aluminum plate caps and start 6-32 x 1/8" setscrews in the tapped holes on the side of the caps. Place the caps, one each, on the plate connections of the 6146 final amplifier tubes and secure with the setscrews. Use care to prevent damage to the tubes.

- (✓) Connect the other end of the bare wire from ground lug 2 of V8 to lug 3 of the 30 K Ω center-tapped bleeder resistor (S-1).
- (✓) Cut an orange hookup wire to 7" in length and strip both ends 1/4". Connect one end to lug 2 of the 30 K Ω center-tapped bleeder resistor (S-1), and connect the other end to the top outer lug of filter capacitor EB (S-2).
- (✓) Cut an orange hookup wire to 4" in length. Strip one end 3/4" and the other end 1/4". Pass the 3/4" stripped end through lug 2 of the 20 K Ω screen dropping resistor and connect to lug 1 of the 30 K Ω center-tapped bleeder resistor. Solder both connections. Connect the other end to the center lug of filter capacitor EB (S-3).
- (✓) Connect the yellow lead from BO#15 to lug 1 of the 20 K Ω screen dropping resistor (S-1).
- (✓) Install the fuse plug on the other end of the line cord as follows: Open the plug to expose the screw terminals. Split the line cord approximately 1" back from the end and separate the leads. Strip the end of the leads to 1/2" and tin. Position the cord in the "bell" of the plug, run the leads along the separate channels provided and connect the wires to the screw terminals with a hook in the same direction as the screw rotation. Reassemble the plug and install two type 3AG fuses rated not higher than 8 amperes.

This completes all wiring of the Kit. The two orange leads connected to FT11 on the outside of the driver housing, and the heavy red lead connected to FT15 on the outside of the final amplifier housing, are purposely left unsoldered at this time. Disconnect these leads from the feed-through capacitors and position them so they don't short out to other components. These leads are left disconnected until neutralization of the final amplifiers is accomplished.

METER SW. POS	MEASURES	SCALE
GRD 1	MULTIPLIER GRID CURRENT	0 - 6 MA *
GRD 2	DRIVER GRID CURRENT	0 - 6 MA *
GRD 3	FINAL GRID CURRENT	0 - 6 MA
PLATE	FINAL PLATE CURRENT	0 - 400 MA
BY	FINAL PLATE VOLTAGE	0 - 1000 VOLTS

*Tune for peak meter reading.

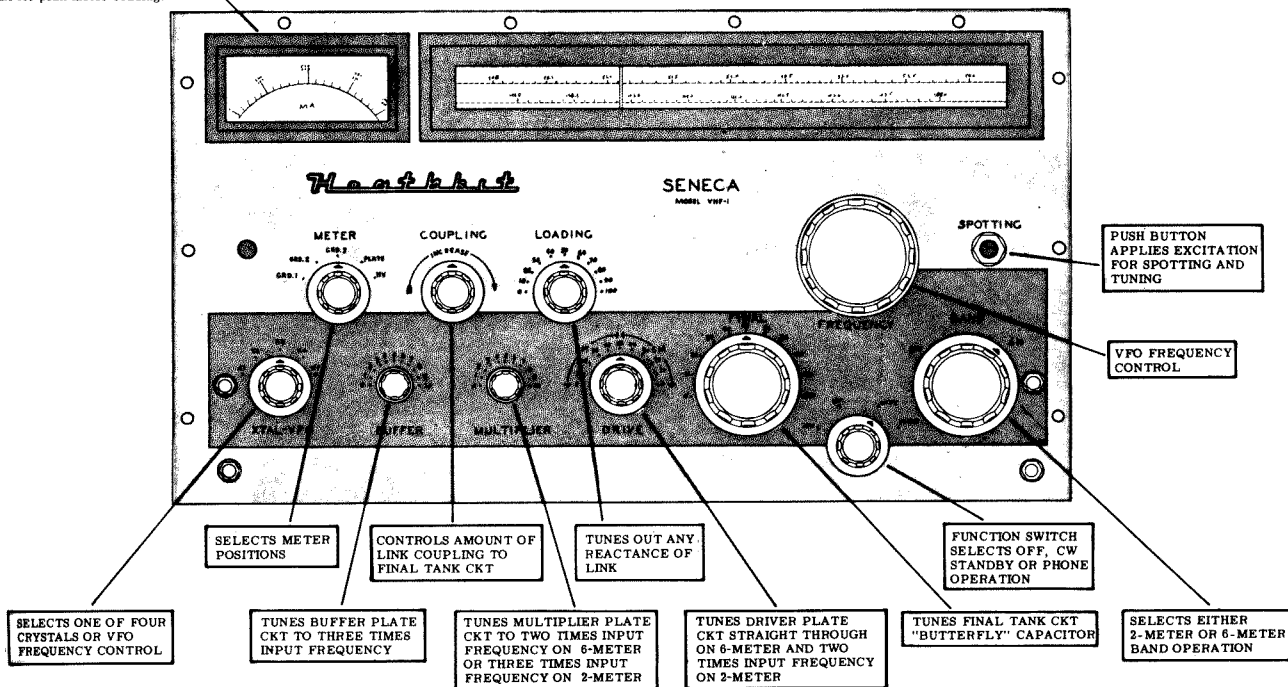

Pictorial 31

- (✓) Install the short length of coaxial cable between the multiplier subchassis and the driver housing.
- (✓) Rotate the shafts of the **BUFFER**, **MULTIPLIER**, **DRIVE**, **FINAL** and **LOADING** capacitors for full mesh of the plates. Refer to Pictorial 31 on page 77 for knob placement.
- (✓) Locate the two split bushings and place over the **BUFFER** and **MULTIPLIER** shafts with the split facing toward the bottom edge of the panel. Now install the two small knobs over the split bushings with the pointers on the knobs facing the "0" marking on the panel and secure, using 8-32 x 1/8" Allen setscrews.
- (✓) Locate the six 1 1/4" diameter knobs and start 8-32 x 1/4" Allen setscrews in each. Install three of the knobs on the **XTAL-VFO**, **METER** and **FUNCTION** switch shafts, positioning the pointer on the knobs opposite the flats on the shafts. Then tighten the setscrews.
- (✓) Install the other three 1 1/4" diameter knobs on the **COUPLING**, **LOADING** and **DRIVE** shafts. Position the pointer of the knob at the **LOADING** location at the "0" marking, and the pointer of the knob at the **DRIVE** location at the "0" marking on the "6M" side of the scale. The **COUPLING** knob does not require any special positioning.
- (✓) Install the large VFO knob at the **FREQUENCY** location, making sure there is clearance between the knob and the front panel escutcheon.
- (✓) Install the remaining 1 3/4" diameter knob on the **FINAL** tuning shaft with the pointer at the "0" marking.
- (✓) A drop of light machine oil on all shaft bushings will insure smooth and easy operation. **CAUTION:** Do not get oil on the dial cord grooves of those shafts that are used to drive dial cords, as slippage will result.

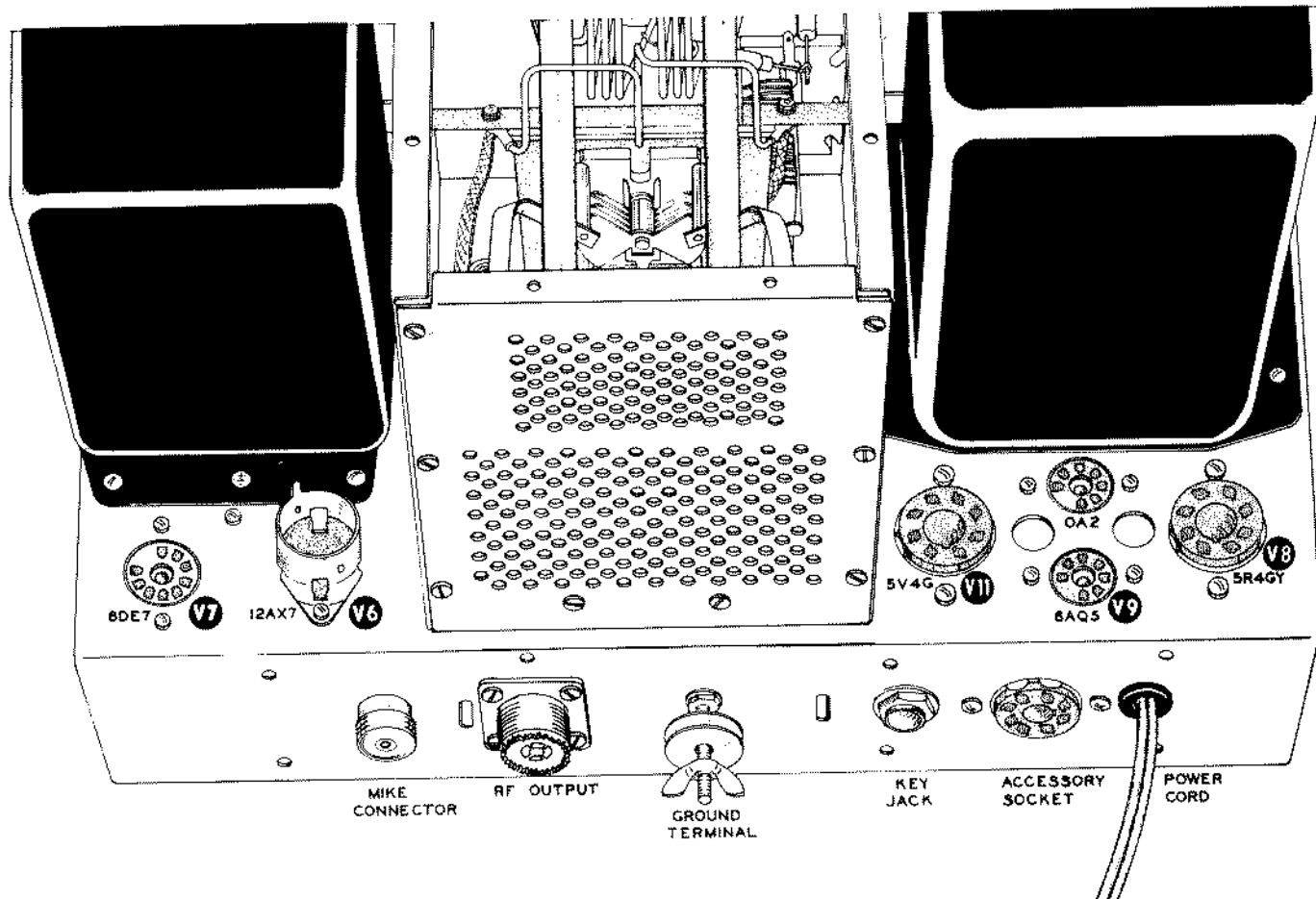

- ✓ Reinstall the 6146 tubes in their sockets V4 and V5. Insert 6-32 x 1/4" screws through the slotted holes in the tabs connected to the tuned lines, then through the silver plated strips connected to the "butterfly" capacitor and secure to the plate caps. Make sure the silver plated strips don't come in contact with the tuned lines other than at the plate caps. Also position the tuned lines so that the ends don't come in contact with the plate caps.
- ✓ Locate the final amplifier back shield. This is the square perforated shield with a 3/8" flange across the top. Mount to the back of the final amplifier housing, using six #6 self-tapping screws and two 6-32 x 1/4" screws.
- ✓ Insert all remaining tubes in their sockets, except the 5R4GY HV rectifier. See Pictorial 32 for identification of sockets. Also install the remaining tube shield over the 12AX7 tube at V6.

PRELIMINARY OPERATION CHECKS

Before applying power to the Transmitter, examine your wiring very carefully for possible shorts, such as tube pins touching, resistor or capacitor leads contacting the chassis or shield housings, and switch contacts shorting to the switch frame. Also be sure no wire clippings or solder drops are still in the chassis.

If there are any short circuits, serious damage will result to the tubes and components when power is applied. As an additional check, connect an ohmmeter from pins 8 of V8 and V11 to ground, with the power off. It should read approximately 30 K Ω or above in all positions of the function switch. Any abnormal low reading must be completely investigated before applying power.

Again, before applying power, check all solder connections. Make sure none have been missed except for the three connections mentioned previously, and that all are good electrical connections. Check the three coaxial cables for continuity and also for possible "shorts" to the coaxial shield.

TESTING, ADJUSTMENT AND CALIBRATION INSTRUCTIONS

Due to the fact that the "Seneca" Transmitter can be operated by three types of licensed amateurs (General, both bands; Technicians, 6-meter band; Novice, 2-meter band 75 watts maximum input, crystal control only), the following adjustments need only pertain to the band that will be used. For the general licensee who wishes to operate both bands, start the adjustment procedure on the 6-meter band and then repeat on the 2-meter band.

See Pictorial 31 on page 77 for a description and the location of all operational controls on the Transmitter before beginning the tuning procedure. A knowledge of each control function will assist in accomplishing the tuning without difficulty.

If crystals are unavailable or are not going to be used refer to page 83 and proceed with the VFO calibration first. Then come back to this page and proceed with the following steps except use the VFO, tuning it from one end of the band to the other, in place of the crystals.

- ✓ Select two crystals, preferably near the band edges, and plug in the *crystal sockets X3 and X4. See Table 1 on page 104. Place the lower frequency crystal in X3 and the high frequency crystal in X4. This will help prevent mixup when checking from one end of the band to the other.

*The crystal socket located near the edge of the multiplier subchassis corresponds to the X4 position on the Xtal-VFO switch, with the second crystal socket from the edge corresponding to X3, etc. When placing crystals in the crystal sockets, remove the line cord from the outlet to prevent possible shock hazard.

(✓) Before applying power, set the controls and switches as follows:

XTAL-VFO:	X3 (or VFO).
BUFFER:	Pointer at "0" setting.
MULTIPLIER:	Pointer at "0" setting.
DRIVE:	Pointer at "50" setting.
FINAL:	Any setting.
FUNCTION:	STBY position.
BAND:	Set band switch to proper band for crystals being used.
METER:	GRD 1 position.
COUPLING:	Full CCW.
LOADING:	Pointer at "0" setting.
FREQUENCY:	No special setting at this time unless VFO is being used.

(✓) At this point, the meter should be studied carefully to determine just how the meter reads for the various positions of the meter switch. First note that the meter has three scales: bottom scale, 0-6 ma; center scale 0-400 ma; top scale 0-1000 volts. The scales should be interpreted as follows:

METER SWITCH POSITION	MEASURES	RANGE OF READING
GRD 1	Multiplier grid current	0-6 ma*
GRD 2	Driver grid current	0-6 ma*
GRD 3	Final grid current	0-6 ma
PLATE	Final plate current	0-400 ma
HV	Final plate voltage	0-1000 volts

* Tune for peak meter reading.

CAUTION: BEFORE APPLYING POWER TO THE TRANSMITTER, IT SHOULD BE NOTED THAT LETHAL VOLTAGES ARE PRESENT BOTH ABOVE AND BELOW THE CHASSIS. CARE SHOULD BE EXERCISED NOT TO TOUCH ANY HIGH VOLTAGE POINTS WITH YOUR HANDS. WELL INSULATED TOOLS SHOULD BE USED FOR ANY ADJUSTMENTS BEHIND THE PANEL.

- (✓) Place the Transmitter upside down for the following steps.
- (✓) Plug the Transmitter into a 117 volt AC, 50-60 cycle outlet and check to be sure that all tubes and dial lights light up. Unplug the line cord if any overheating is observed.
- (✓) If nothing unusual is observed under these conditions after a short time, depress the spotting push button switch and adjust the buffer tuning control for a peak reading on the meter. The average crystal should give a reading to about midscale on the meter.
- (✓) Now move the meter switch to the GRD 2 position. Depress the spotting push button switch again and adjust the multiplier tuning control for a peak reading on the meter. With the band switch in the 6-meter position you should get almost a full scale indication, and in the 2-meter position you should get about a midscale indication. If more than one meter indication occurs, always tune for the largest indication.
- (✓) At this point, change crystal positions and repeat the two above steps. If the readings obtained on the meter with the meter switch in the GRD 2 position differ, between the two crystals, by a large margin and the meter indication shows about equal indications in the GRD 1 position, check the LC ratio of the multiplier plate tank circuit. If the multiplier tuning capacitor plates are completely meshed for peak meter indication when using the

low frequency crystal, compress the turns on the tank coil slightly. (If the band switch is in the 6-meter position this will be the coil with six turns, and with the band switch in the 2-meter position it will be the three turn coil.) If the tuning capacitor plates are completely open for peak meter indication when using the high frequency crystal, spread the turns on the tank coil slightly.

Now move the meter switch to the GRD 3 position. Depress the spotting push button switch and adjust the drive tuning control for peak meter indication but do not exceed 6 ma. Normal final grid current should be about 4.5 ma on both bands. Again, if normal meter indication occurs with one crystal but not with the other, check the LC ratio of the driver tank circuit. NOTE: With the band switch in the 2-meter position and with a crystal operating at the high end of the band, the driver tank capacitor will be almost completely out of mesh; the reverse is true with the band switch in the 6-meter position, using a crystal at the low end of this band.

If the driver tank coil has to be adjusted, the turns will only have to be spread or compressed slightly. If the LC ratio of the driver tank circuit has been corrected or appeared to be correct and still sufficient final grid drive cannot be obtained, it will be necessary to adjust the position of the final grid tank coupling coils. See Detail 23 for identification of the coils. Only a slight adjustment of the coils for coupling is necessary.

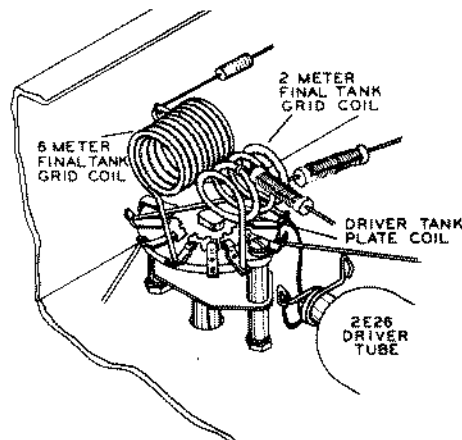

CAUTION: Use an insulated tool when making these adjustments. If adjustment of the final grid tank coils was necessary, there will be some interaction to the driver tank coil and its turns may have to be readjusted.

Detail 23

- 1) When proper operation of the multiplier and driver circuits is obtained, install the multiplier bottom shield to the multiplier subchassis and secure with six #6 self-tapping screws. Be sure the screw ends do not come in contact with any components in the subchassis.
- 2) Locate the driver bottom shield. This is the shield with perforations in the center and a 1/4" flange at one end. Butt the flange end against the rear apron of the chassis and secure in place with six #6 self-tapping screws.
- 3) Turn the transmitter over in its normal position.

NEUTRALIZATION ADJUSTMENT

The final amplifier tubes are neutralized to reduce to a minimum the RF driver voltage fed from the input of the final amplifier to the output tank circuits through the grid plate capacitance and the inherent inductance of the screen leads within the tubes to prevent self-oscillation or regeneration. This is done by adjusting carefully, bit by bit, the neutralizing stubs in the final amplifier compartment until an RF indicator coupled to the final plate tank circuits reads minimum. Both neutralizing stubs are adjusted simultaneously and to approximately the same physical positions until minimum RF is indicated for resonant settings of both the drive and final tuning capacitors.

(✓) Refer to Detail 24 and notice that the two stubs that cross over the top of the switch wafer are the 6-meter neutralizing stubs and the other two are the 2-meter neutralizing stubs.

(✓) Select a crystal frequency near the low end of the band being used, or if normal operation is proposed in one section of the band, select a crystal in the middle of that section. Turn the function switch to the CW position. You should hear the relay being energized. Tune the buffer, multiplier, and drive tuning controls as before for peak meter indications. Loosely couple an RF indicator (a grid dip meter or a wave meter are ideal instruments) to the final tank circuit. Adjust the final tuning control for a peak indication on the RF indicator. Now adjust the neutralizing stubs (using an insulated tool such as the nut starter) for a null or minimum indication on the RF indicator. Readjust the final tuning control for peak indication again, and again adjust the neutralizing stubs for minimum indication. As neutralization is accomplished, it will be necessary to couple the RF indicator closer to the tank circuits for ample indication. Repeat the above procedure until further adjustments produce no further minimum indication. With the meter switch in the GRD 3 position, adjust the Final tuning control slowly through resonance and if the meter indication on the front panel remains constant, good neutralization is indicated. A further check of neutralization will be made later.

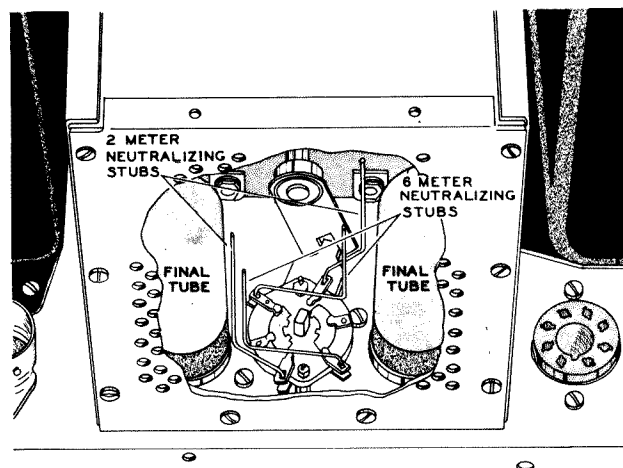

Detail 24

(✓) Turn the function switch back to STBY and unplug the line cord.

(✓) Connect the heavy red lead back on FT15 (S-1).

(✓) Connect the two orange leads back on FT11 (S-2).

(✓) Locate the octal plug and connect a bare wire jumper from pin 3 to pin 4. Solder both connections. Snap the octal plug shield in place. Install the octal plug in the accessory socket.

(✓) Install the 5R4GY HV rectifier tube in socket V8. Apply power to the Transmitter with the function switch in STBY position and allow to warm up a few minutes.

(✓) If a 50 or 72 Ω pure resistive load is available, connect it to the RF coaxial output connector on the rear apron of the chassis. An alternate load can be made up, using a 60 watt light bulb. Unfortunately, the common light bulb has high inductive reactance at these frequencies, but if the light bulb load is made up as shown in Detail 25, it will suffice for preliminary adjustments of the Transmitter. NOTE: The brilliance of the light bulb is not a true indication of the actual power output capabilities of the Transmitter. If the light bulb load is used, install directly on the coaxial connector at the rear of the chassis.

(✓) Rotate the coupling tuning control CW and check to be sure the link coupling does not come in contact with the tuned lines or the 6-meter tank coil during its travel. Return the link coupling coil to its original position.

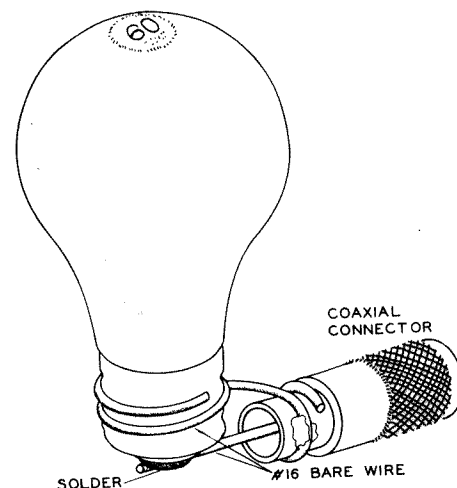

Detail 25

✓ To test the final amplifier, be sure the preceding stages are all tuned for peak meter indication (GRD 3 maximum of 6 ma). Move the meter switch to the "Plate" position and turn the function switch to the CW position. Return the switch to STBY immediately in case of an arc, apparent overload, or an excessive meter reading (over 350 ma). Adjust the final tuning control quickly for a minimum meter indication. Now slowly adjust the coupling control CW while maintaining a minimum meter indication with the final tuning control. As the coupling is increased, the minimum meter indication should increase, as should the light bulb's brilliance. At the same time, adjust the loading control for maximum meter indication. Repeat this procedure, adjusting the three individual controls until a normal operating load of 230 ma of plate current indication is reached. Recheck the amount of grid drive. If the reading has dropped, readjust the drive control for maximum grid indication (not over 6 ma), then recheck the final plate current. Depending upon the type of light bulb being used for a dummy load, you may find it difficult to load the final amplifier to the normal load of 230 ma. In this case, adjust for maximum bulb brilliance at minimum plate current indication. Return the function switch back to STBY position.

✓ Connect a crystal, ceramic, or high impedance dynamic microphone to the mike connector on the rear apron of the chassis. Move the function switch to the "Phone" position. Notice the plate current indication is about 50 ma. Now speak into the mike. The plate current should swing upscale to about 200 ma with the light bulb varying in brilliance each time you speak into the mike. Return the function switch back to STBY position.

✓ To check CW operation, insert the plug from a key into the key jack. Move the function switch back to the CW position. With the meter switch still in "Final" position, notice that the resting plate current is about 50 ma. This indicates that the 6AQ5 clamp tube is operating properly. Now depress the key and the light bulb should light with the plate current rising to the normal operating load of 230 ma.

The tuning procedure just outlined will also apply when loading an actual antenna. Antenna and grounding considerations will be covered later.

VFO CALIBRATION

An electronic counter of good quality, a frequency standard such as the surplus LM or BC series, or a 100 KC crystal calibrator are all excellent pieces of equipment for calibration, if properly used and checked against WWV. For those kit builders that do not have access to the type of equipment just mentioned, a selection of crystals, preferably near the band edges, should be accumulated.

NOTE: Not all crystals are exactly on frequency as marked on the crystal holder due to aging, poor original calibration or oscillator circuit variations. This is particularly true of the surplus type of crystals.

The crystals may be installed in the *crystal sockets of the Transmitter and compared to the VFO frequency by means of a nearby receiver having a BFO. If a frequency meter or a crystal calibrator is used, it can beat against the VFO frequency in the receiver. A frequency counter, of course, can count and display the VFO frequency directly. (Do not use ordinary radio service generators.) The receiver must be capable of tuning between 8000 KC and 9000 KC, or the harmonics of these frequencies such as 16, 24, 32,, 50 or 144 MC.

*The crystal socket located near the edge of the multiplier subchassis corresponds to the X4 position on the Xtal-VFO switch, with the second crystal socket from the edge corresponding to X3, etc. When placing crystals in the crystal sockets, remove the line cord from the outlet to prevent possible shock hazard.

Before beginning calibration, remove the 5R4GY high voltage rectifier tube and insert the plug from a key in the key jack. Leave the key open during the calibration procedure. With the function switch in STBY position, allow the Transmitter, frequency meter or crystal calibrator, if used, and receiver to warm up for at least one half hour or more.

During the calibration procedure, the function switch should be on the CW position and the meter switch in the GRD 1 position. If a frequency meter is used for calibration, the frequency meter signal and the VFO signal should be zero beat against each other in a receiver with the BFO off. Be sure to avoid setting the receiver on image frequencies. Under these conditions the VFO frequency is the same as the frequency meter. See Figure 10A. If crystals are being used for calibration, set the receiver to the crystal frequency with the BFO on and zero beat the BFO in the receiver against the crystal oscillator signal from the Transmitter. Then set the VFO to zero beat against the receiver, which is still tuned to the crystal frequency. Under these conditions, the VFO frequency is the same as the crystal frequency. See Figure 10B.

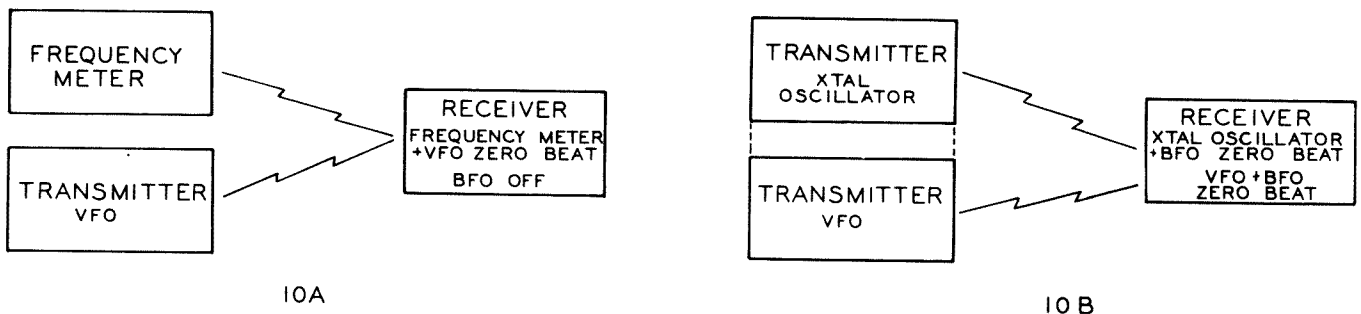
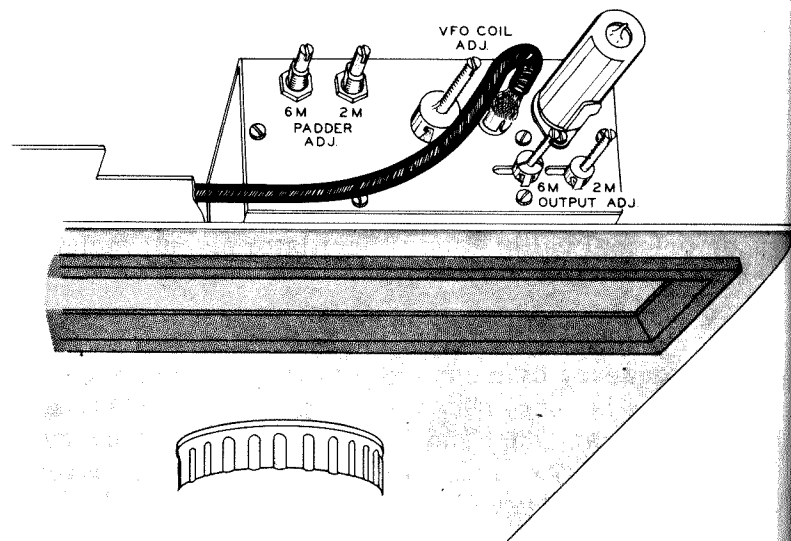

Figure 10A & 10B

If a crystal calibrator is used for calibration, be sure you know which marker is the proper frequency. Aside from these slight differences in measurement technique, the following procedure may be used for either method of calibration. Refer to Pictorial 33 for location and identification of the various calibrating adjustments.

NOTE: It should be noted that the trimmer capacitors (6M and 2M in Pictorial 33) are used to set the bandspread covered on the dial while the VFO coil slug is used to set a definite frequency point on the dial. The slug is set to the calibration frequency near the low end of the dial and the trimmers are adjusted so that the calibration frequency at the high end of the band coincides with the dial reading. These two adjustments interact with each other and, therefore, will have to be adjusted alternately until optimum overall calibration is obtained. Both trimmer capacitors should be set to full



Pictorial 33

open (both plates completely unmeshed) before starting calibration, as indicated by the marks placed on the shafts and chassis when the VFO subchassis was mounted. Make sure the steps regarding the setting of the VFO tuning capacitor in relation to the dial mechanism were not overlooked or done improperly.

CALIBRATION WITH FREQUENCY METER

For 6-meter calibration, adjust the VFO tuning so that the dial pointer sets over the 50.0 marking. Set both the frequency meter and the receiver to 8334 KC with the receiver BFO off. Adjust the VFO coil slug for zero beat against the frequency meter signal in the receiver. Now set the dial pointer over the 54.0 marking and set the frequency meter to 9000 KC. Tune the receiver toward 9000 KC with the BFO on and note the dial reading where the VFO zero beats with the receiver. Then set the receiver to 9000 KC with the BFO off and adjust padder 6M for zero beat in the receiver. Return the dial pointer to the 50.0 mark and reset the frequency meter and receiver to 8334 KC. Readjust the VFO coil slug for zero beat once again. Move the dial pointer back to the 54.0 calibration mark and when tuning the receiver back to 9000 KC with the BFO on again, it should be found that the dial reading for zero beat is closer to the actual frequency than before. Adjust padder 6M again for zero beat with the frequency meter and receiver reset to 9000 KC and repeat this process until calibration is achieved at both ends of the band.

For 2-meter calibration, move the band switch to the 2M position. Adjust the VFO tuning so that the dial pointer sets over the 144.0 marking. Set both the frequency meter and receiver to 8000 KC and adjust padder 2M only for zero beat. This is the only adjustment necessary if the 6-meter calibration has been done properly, since the VFO coil is common to both bands.

CALIBRATION WITH CRYSTALS

The calibration procedure outlined above using a frequency meter can be repeated using crystals, except the receiver will be set to zero beat, with the BFO on constantly, against the Transmitter crystal oscillator frequency. Move the Xtal-VFO switch to the low frequency crystal position and zero beat the receiver. Now move the Xtal-VFO switch to the VFO position and tune the VFO so that the dial pointer sets over the dial marking which corresponds to the crystal frequency. (Refer to Page 104 at the back of the manual for interpolation of the dial readings against the fundamental frequency of the VFO.) Adjust the VFO coil slug for zero beat in the receiver, with the receiver still tuned to the crystal frequency. Now move the Xtal-VFO switch to the high frequency crystal and tune the receiver to zero beat against this crystal frequency. Return the Xtal-VFO switch back to VFO position and set the VFO dial pointer over the dial mark corresponding to the high frequency crystal. Adjust padder 6M for zero beat in the receiver with the receiver still tuned to the high frequency crystal. As mentioned before, repeat this process until calibration is achieved. For 2-meter calibration, use the proper crystal frequency for that band.

- () After VFO calibration is complete, adjustment of the output coils may be accomplished. Move the band switch to the 6M position and set the VFO dial pointer to the middle of the band (52 mc). Tune the buffer control for maximum meter indication (meter switch in GRD 1 position). Now adjust output coil slug 6M for maximum meter indication.
- () Move the band switch to the 2M position and repeat the above step except adjust output coil slug 2M. Meter indication on both bands should read about half scale.

NOTE: Peaking the output coils may affect VFO calibration, therefore it may be necessary to touch up VFO calibration.

- () If the TESTING and ADJUSTMENT INSTRUCTIONS have not been followed, refer back to Page 79. Otherwise this completes testing, adjustment and calibration of your VHF-1 Transmitter.

INSTALLATION OF TRANSMITTER IN CABINET

- () Mount the final amplifier top shield, with the larger perforation area towards the back of the housing, using eight #6 self-tapping screws.
- () Install the four large rubber feet on the cabinet. Use 8-32 x 3/8" screws, inserting the screws through the rubber feet and then through the cabinet bottom. Use #8 lockwashers under the nuts and tighten securely.
- () Place the Transmitter in front of the cabinet and pass the line cord through the opening in the back of the cabinet. Now slide the Transmitter onto the rails and into the cabinet while guiding the line cord through the opening in the back. Use ten #10-32 Phillips head screws to fasten the front panel to the cabinet, and eight #6 sheet metal screws through the back of the cabinet into the rear chassis apron.
- () Place the rear apron diagram adhesive label on the back of the cabinet, just above the opening on the solid metal between the two center sheet metal screws.

Your Heathkit VHF-1 Transmitter is now ready for installation and operation.

OPERATION

NOTE: It should be noted that an Amateur Radio Operator and Station License is required to place this transmitter on the air. Information regarding licensing and amateur frequency allocations may be had from publications of the Federal Communications Commission or the American Radio Relay League.

The tuning procedure outlined previously will also apply when loading an actual antenna. A point not covered under the tuning procedure is the method by which the VFO may beat against an incoming signal without placing the Transmitter on the air. When operating either PHONE or CW, depressing the spotting push button on the front panel will provide a signal from the exciter stages of the Transmitter that can be picked up on the receiver. Then the VFO can be tuned for zero beat against the incoming signal. If the frequency excursion is more than 200 kc, it may be necessary to retune the buffer, multiplier, and driver stages. When the Transmitter is again placed on the air, the final amplifier may require touching up to compensate for the frequency change.

For operation on 2-meters, reduce the loading to 185 ma of final plate current in order to prolong longer final amplifier tube life.

Novice Operation: At the press time of this manual the maximum power input for novice operation is 75 watts crystal control only between the frequency ranges of 145 to 147 megacycles. Either PHONE or CW operation is permissible within this frequency range. Maximum loading point for 75 watts input is 125 ma of final plate current.

A further check on the neutralization can be made by noting whether maximum grid current indication occurs at the same point of tuning on the final tuning capacitor as minimum plate current indication. As the final tuning capacitor is detuned slightly from resonance on either side, the grid current of the final stage should decrease the same amount and without any sudden jumps on either side of resonance. This indicates accurate neutralization provided the load is non-reactive at the operating frequency.

Be sure and check the neutralization each time a final amplifier tube is replaced.

Accessory Socket

See Figure 11 for a diagram of the accessory socket. This is the octal socket located on the rear apron of the chassis. It provides connections for external duplication of the function switch and provides 117 volts AC for antenna or receiver muting relay. It also has a connection for receiver muting which is wired "normally closed".

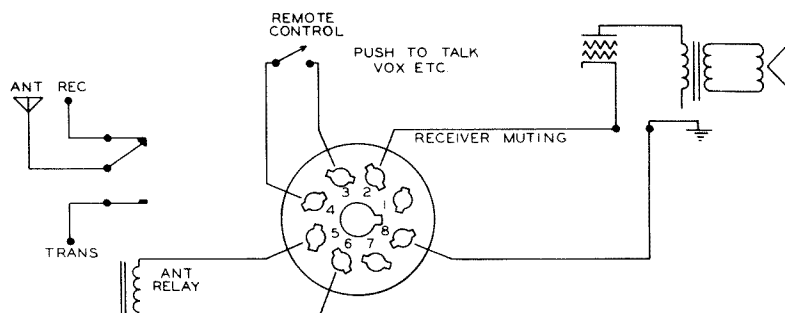

Figure 11

Antennas and Grounding

The link coupling network output circuit of the VHF-1 Transmitter will match pure resistive loads from approximately 50 to 72 Ω . Therefore, the Transmitter will match antennas and unbalanced transmission lines within these limits, provided such antennas or transmission lines are non-reactive. Most commercial or "home-brewed" antennas, including beams, and verticals in use today are designed to be fed with 50 or 72 Ω coaxial cable. If an antenna with a balanced transmission line is desired, it is recommended that an antenna coupler be obtained or a balun be made up. Such units are available commercially or can be built from published literature at a reasonable cost. An antenna coupler is almost a necessity to properly match transmission lines of high impedance used to feed antennas such as the "V" or rhombics, but a simple balun can be made of coaxial cable to match the Transmitter output to a balanced feed line. Such a system is shown in Figure 12. NOTE: Baluns of this type offer only a 4:1 impedance match. Thus, an antenna which is matched to a 300 Ω balanced transmission line, should have a balun made of 72 Ω coax, with the unbalanced line connected to the Transmitter being of 72 Ω coax also. Either transmission line may be of any length.

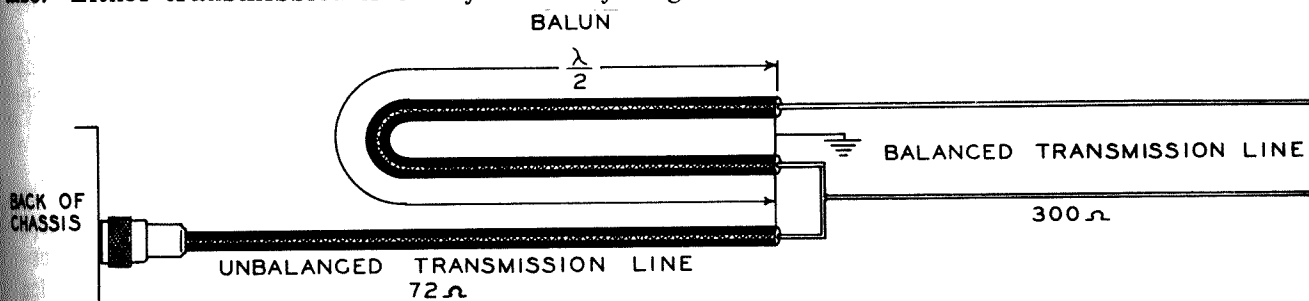

Figure 12

Low Pass Filters

The harmonic rejection of the link coupling output circuit of the VHF-1 is good and will attenuate harmonics considerably when the Transmitter is properly grounded and carefully tuned. However, additional harmonic attenuation may be had with the use of a low pass filter connected between the output of the Transmitter and the feed line to the antenna. Such a filter should be designed to handle the maximum power output of the Transmitter and must be operated into its nominal impedance.

Grounding

Proper grounding techniques are very important at these frequencies. A flexible braid or copper strap at least 1/2" wide should be connected to the ground lug of the Transmitter located on the rear apron of the chassis and connected to a ground rod which extends into the earth at least 6 feet. Make the run as short and direct as possible. If the Transmitter location and ground rod are over a half wave length away from each other at the operating frequency, a system of three or more grounding straps, each one a different length, should be connected to the ground rod. Do not use gas pipes, electrical conduit or water pipes that are a part of the structure of a dwelling. Water pipes are not good grounds, because of the pipe compound used on pipe joints and the corrosion that develops between the joints.

Much has been published on the subject of antennas and matching devices and excellent articles can be found in the various radio journals and magazines.

Whatever type of antenna system is used, the maximum loading point of 230 ma of final plate current should not be exceeded.

IN CASE OF DIFFICULTY

Mistakes in wiring are the most common cause of difficulty. Consequently, the first step is to recheck all wiring against the pictorials and schematic diagrams. Often having a friend check the wiring will locate an error consistently overlooked.

With miniature sockets, there is a possibility of shorts between adjacent socket terminals due to the close spacing. This should be checked and if any doubt exists, the terminals should be pried apart until obvious spacing can be seen between them.

Sometimes apparently good solder connections will have an insulating coating of rosin between the wire, the terminal and the solder. This is often the case when insufficient heat was applied in soldering. An ohmmeter check of any questionable connections will test for this condition. Naturally, all voltages should be "off" for such tests.

The Transmitter is fused at the line cord plug. A type 3AG fuse is required on each side of the line plug with a rating not in excess of 8 amperes. Should it be found that fuses consistently blow whenever the equipment is plugged in and the function switch is in STBY, resistance tests of both power supplies should be made. Check the primary circuits, filament circuits, and the relay circuits for possible shorts. If a fuse blows whenever the function switch is in either PHONE or CW position, the resistance tests of both B+ circuits should be made and both rectifier tubes should be checked. In either case, it is important that the line plug be removed from the outlet when the resistance measurements are made. As additional insurance against shock, a screwdriver blade should be used to short from the chassis to the hot end of the bleeder resistor and from the center lug to one of the outer lugs of each filter capacitor so that they will be thoroughly discharged.

Be sure to reread the circuit description on Page 3 so that "cause and effect" reasoning may be employed as the search for trouble progresses. If some difficulty still persists after the steps outlined have been completed, attempt to localize the trouble to a particular stage in the Transmitter circuit. Use the tuning procedure and voltage chart on Page 102 as a basis for localization and refer to the block diagram and schematic to visualize circuit relationships. The panel meter and station receiver are extremely valuable tools to use in locating trouble.

The receiver and/or appropriate converters may be used to check each RF section of the Transmitter by connecting a short length of insulated wire to the receiver and/or converter antenna terminal and bringing the wire near the RF section. Tune the receiver with the BFO on, to determine if a signal is being generated by the respective section. A grid dip meter and wave meter are ideal instruments for checking the RF circuits. Coupling either instrument to the RF section in question will determine if the proper signal is being generated. Last, but not least, a Volt-ohm-milliampere meter (preferably 20,000 ohm/volt) should be available for measuring voltage, resistance, and current.

Due to the complexity of the VHF-1 Transmitter, certain difficulties could arise. Outlined below are some of the possible indications of improper operation and their causes.

TROUBLE

No meter indication in GRD1 position with Xtal-VFO switch in proper crystal position.

POSSIBLE CAUSES

Bad crystal - try different crystal.
Xtal-VFO switch in unused crystal socket position.

TROUBLE

No meter indication in GRD 1 position, with Xtal-VFO switch in VFO position, but have proper meter indication when using crystals.

No meter indication in GRD 2 position.

No meter indication in GRD 3 position.

POSSIBLE CAUSES

Defective 6AN8 tube (pentode section).
Xtal-VFO switch wired incorrectly.
RFC 2 open.

VFO not calibrated properly.
VFO band switch wired incorrectly.
VFO output coils detuned.
Coaxial cable between VFO subchassis and multiplier subchassis either shorted or open.
Xtal-VFO switch wired incorrectly.
RFC 1 open. *
Defective 6AU6 tube.
Defective OA2 regulator tube.

*RFC 1 can be checked for continuity by removing the 6AU6 VFO tube from its socket and inserting the ohmmeter probe into pin 7. Connect the other ohmmeter probe to the VFO subchassis. You should have a reading of about 20 Ω .

Coaxial cable between multiplier subchassis and driver housing either shorted or open.
Defective or improper bypass capacitor C18.
Multiplier tank coils L5-L6 not adjusted properly.
Multiplier band switch not moving into position properly.
Band switch in wrong position for crystal frequency being used.
Band switch linkage mechanism adjusted improperly.
2E26 driver tube cathode circuit open (incorrect wiring or defective spotting push button switch).
Defective 6AN8 tube (triode section).
Defective 2E26 tube.

Driver band switch in wrong position for crystal frequency being used.
Band switch linkage mechanism improperly adjusted.
Driver tank coil L7 not adjusted properly.
Incorrect wiring to driver band switch.
Coils improperly wired to driver band switch.
The #16 bare wire leads going through the 5/16" holes in the main chassis shorting to the chassis.
Lug 3 or 9 on the neutralization band switch shorting to the base sleeves of the final amplifier tubes.
Neutralization stubs shorting to the band switch mounting screws, base sleeve of the final amplifier tubes, or to the amplifier back shield.
Defective 2E26 driver tube.
Defective 6146 final amplifier tube.

TROUBLE

Insufficient grid drive (low meter indication in GRD 3 position).

Unable to dip final amplifier (meter switch in PLATE position).

Excessive plate current.

Unable to load Transmitter properly.

Insufficient plate current would indicate low plate voltage and this can easily be checked with the panel meter in the HV position. You should have a meter indication of approximately 600 volts. If not, possible causes could be: incorrect wiring of high voltage circuit; defective 5R4GY tube; open HV filter choke; filter capacitors EA and EB wired incorrectly or are leaky; defective meter multiplier resistor R20.

Other possible causes for the above outlined troubles could be defective meter shunts or meter.

POSSIBLE CAUSES

Check all possible causes mentioned above. Improper coupling (positioning) of grid tank coils L8-L9.

Improper or defective bypass capacitors C25-C26 from the screen circuits of the final amplifier tubes to ground.

Improper lead dress of leads connected from screens of final amplifier tubes (pins 3 of V4 and V5) to FT11. (Dress these leads close to the chassis and away from RF circuitry as much as possible.)

Final tank band switch (rotor) in wrong position for band being used.

With band switch in 6M position, LC ratio of final 6-meter tank coil L10 incorrect. (Using a grid dip meter or a wave meter, check resonant frequency range of final tank circuit.)

Defective 6146 tube.

Final tank circuit not tuned to resonance.

Link coupling coil shorting to tuned lines or 6-meter tank coil.

Shorted feed-through capacitor FT15.

Loading increased too much.

Incorrect neutralization.

Defective RF choke RFC 8.

Final tank band switch in wrong position for crystal frequency being used. *

Defective 6146 tube. *

*These two possible causes also indicate trouble in the 6AQ5 clamp circuit which could be due to a defective 6AQ5 tube or incorrect wiring in the clamp circuit.

Coaxial cable from final amplifier housing to output connector either open or shorted. Impedance of transmission line incorrect, (must be 50 to 72 Ω from Transmitter).

Impedance match of antenna or dummy load to transmission line incorrect.

Open or shorted transmission line.

(See discussion of Antennas on Page 87.)

Final amplifiers not neutralized.

Defective 6146 tube.

Handwritten notes: 1200, 1300, 1400, 1500, 1600, 1700, 1800, 1900, 2000, 2100, 2200, 2300, 2400, 2500, 2600, 2700, 2800, 2900, 3000, 3100, 3200, 3300, 3400, 3500, 3600, 3700, 3800, 3900, 4000, 4100, 4200, 4300, 4400, 4500, 4600, 4700, 4800, 4900, 5000, 5100, 5200, 5300, 5400, 5500, 5600, 5700, 5800, 5900, 6000, 6100, 6200, 6300, 6400, 6500, 6600, 6700, 6800, 6900, 7000, 7100, 7200, 7300, 7400, 7500, 7600, 7700, 7800, 7900, 8000, 8100, 8200, 8300, 8400, 8500, 8600, 8700, 8800, 8900, 9000, 9100, 9200, 9300, 9400, 9500, 9600, 9700, 9800, 9900, 10000.

If resistance checks of the shunts are made, make sure the meter is disconnected from the circuit. This can be done by moving the meter switch off of the meter shunt circuit being checked.

Inability to obtain modulation could be indicative of trouble in the speech amplifier or modulator circuits, or may simply show a defect in the microphone or cable. Isolate the trouble by disconnecting the microphone connector from the mike input and touch the center portion of the mike input with your finger. The meter will move upscale if the speech amplifier and modulator circuits are all right, pointing to trouble in the microphone or cable. If the meter does not move upscale, this could indicate incorrect wiring of the modulator circuits, or of the function switch. Refer to the voltage chart for checking the modulator circuit.

To aid in trouble shooting, the cable harness leads are marked as to color on the schematic.

SERVICE

If, after applying the information contained in this manual and your best efforts on the unit, you are still unable to obtain proper performance from the Transmitter, it is suggested that you take advantage of the technical facilities which the Heath Company makes available to its customers.

The Technical Consultation Department is maintained for the purpose of providing Heath customers with a personalized technical consultation service; this service is available to you without charge. The technical consultants are thoroughly familiar with all details of the Transmitter and can usually localize the trouble from a suitable description of the difficulty encountered. It is, of course, necessary that you provide full and complete information concerning your problem when writing to the Technical Consultation Department for assistance. For instance, clearly identify the kit involved, giving the purchase date and, if possible, the invoice number; describe in detail the difficulty that you have encountered; state what you have attempted to do to rectify the trouble, what results have been achieved, and include any information or clues that you feel could possibly be of value to the consultant who handles your problem. Failure to provide complete descriptive details may lead to incorrect assumptions on the part of the consultant and needless delay in the solution to your problem. Quite frequently, when the information given the consultant is complete, concise and reliable, a diagnosis of the difficulty can be made with confidence and specific instructions given for its correction. If replacement of a component is involved in the correction, the component will be shipped to you, subject to the terms and conditions of the Warranty.

The Factory Service facilities are also available to you, in case you are not familiar enough with electronics to provide our consultants with sufficient information on which to base a diagnosis of your difficulty, or in the event that you prefer to have the difficulty corrected in this manner. You may return the completed Transmitter to the Heath Company for inspection and necessary repairs and adjustments. You will be charged a fixed fee of \$20.00, plus the price of any additional parts or material required. However, if the Transmitter is returned within the Warranty period, parts charges will be governed by the terms of the Warranty. State the date of purchase and give invoice number, if possible.

Local Service by Authorized Heathkit Dealers is available and often will be your fastest, most efficient method of obtaining service for your Heathkits. Although you may find charges for local service somewhat higher than those listed in Heathkit manuals (for factory service), the amount of increase is usually offset by the transportation charges you would pay if you elected to return your kit to the Heath Company.

Heathkit dealers will honor the regular 90 day Heathkit Parts Warranty on all kits, whether purchased through a dealer or directly from Heath Company. It will be necessary that you verify the purchase date of your kit by presenting your copy of the Heath Company invoice to the authorized dealer involved.

Measurements made with Heathkit VOM (20,000 ohms/volt) meter with controls set as follows unless otherwise noted: Reading may vary $\pm 20\%$ of those listed.

Function Switch: STBY
 Band Switch: 6 M or as noted
 Xtal-VFO Switch: VFO

Adjust buffer, multiplier and drive controls for 4.5 ma in GRD 3 meter position.
 Adjust final, coupling and loading controls for 230 ma in PLATE METER position.

All voltages are DC unless otherwise noted.

All voltage checks are made by depressing spotting push button switch unless otherwise noted.

VOLTAGE CHART

TUBE	PIN 1	PIN 2	PIN 3	PIN 4	PIN 5	PIN 6	PIN 7	PIN 8	PIN 9	PLATE CAP
V1 (VFO 6AU6)	① -12	0	0	6.3 AC	300	150	.2	—	—	
V2 (Xtal Osc.) (Mult. 6AN8)	300	①② -70 ①③ -135	14	0	6.3 AC	300	180	① -9	8	
V3 (Driver 2E26)	4	6.3 AC	② 65 ③ 200	4	①② -55 ①③ -35	4	0	0	—	④ 300
⑦ V4 V5 (Final 6146's)	0	0	② 175 ⑧⑨ 50	0	⑤ -55	0	6.3 AC	0	—	⑥ 600
⑧⑨ V6 (Sp. Amp. 12AX7)	125	0	1.3	6.3 AC	6.3 AC	75	.3	0	0	
⑧⑨ V7 (Mod. 6DE7)	300	NC	20	6.3 AC	0	20	.5	0	70	
⑦ V8 (HV Rect. 5R4GY)	NC	⑩ 620	NC	800 AC	NC	800 AC	NC	⑩ 620		
⑦ V9 (Clamp 6AQ5)	⑤ -55 ⑪ 0	0	6.3 AC	0	⑪ 175 15	⑪ 300 145	NC			
V10 (Voltage Reg. OA2)	150	NC	NC	NC	150	NC	0			
V11 (LV Rect. 5V4G)	NC	⑩ 315	NC	400 AC	NC	400 AC	NC	⑩ 315		

The above readings will be slightly higher if a VTVM is used.

- ① These measurements were made with a RF choke of approximately 1 mh in series with the DC probe. The RF choke will detune the circuit slightly, so it is necessary to retune with the probe in the circuit.
- ② Band switch in 6M position.
- ③ Band switch in 2M position.
- ④ Measure at FT10.
- ⑤ Measure at FT13 (reading will vary, depending upon amount of grid drive).
- ⑥ Measure at FT15.
- ⑦ Function switch in CW position.
- ⑧ Function switch in PHONE position.
- ⑨ No audio signal input.
- ⑩ 5 volts AC measured across pins 2 and 8. Measure only if absolutely necessary. Be sure function switch is in STBY position when measuring across these pins.
- ⑪ Key inserted in key jack with key open.



XTAL. OSC AND MULTIPLIER SECTION

6AN8

DRIVER SECTION

2F26

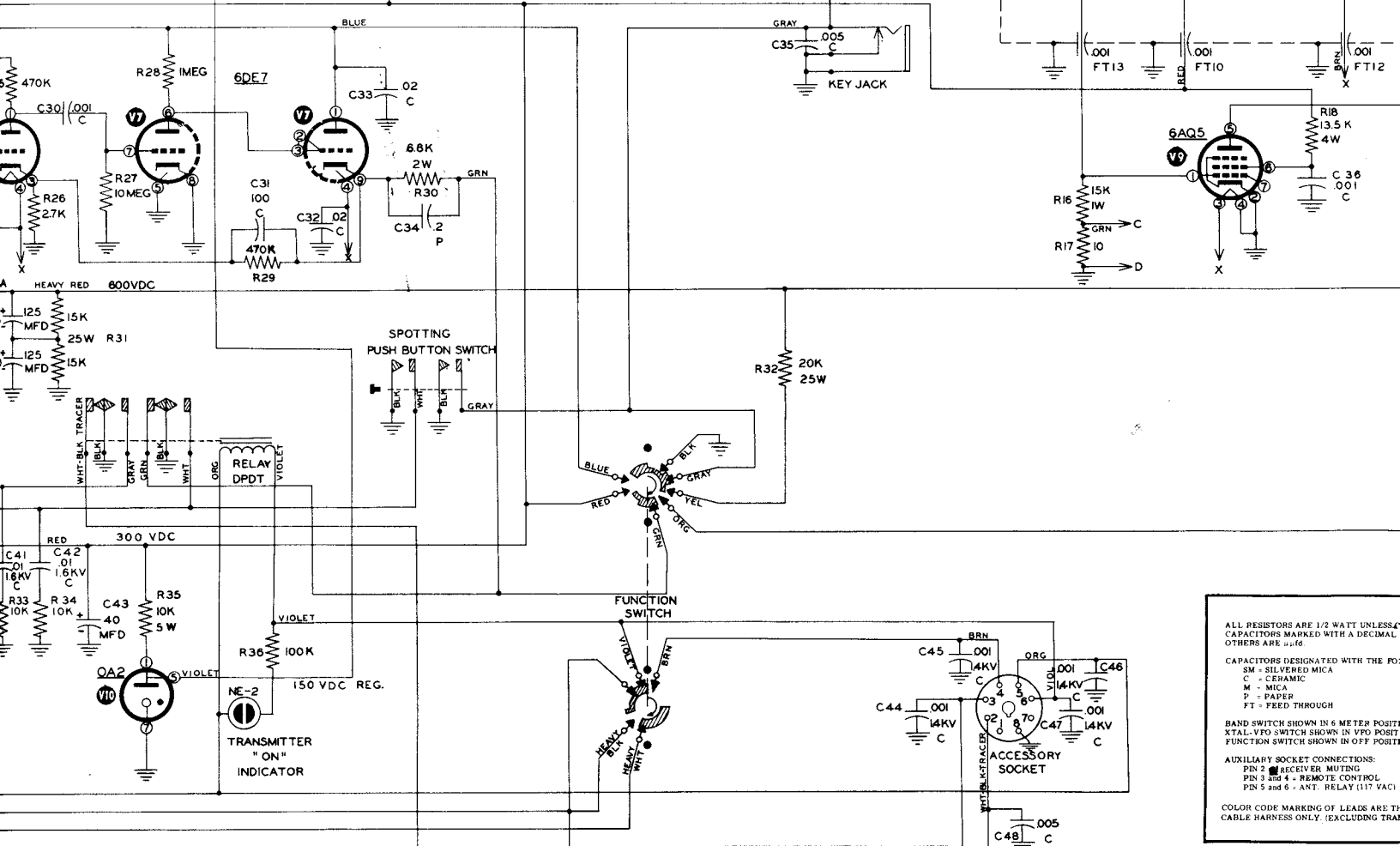
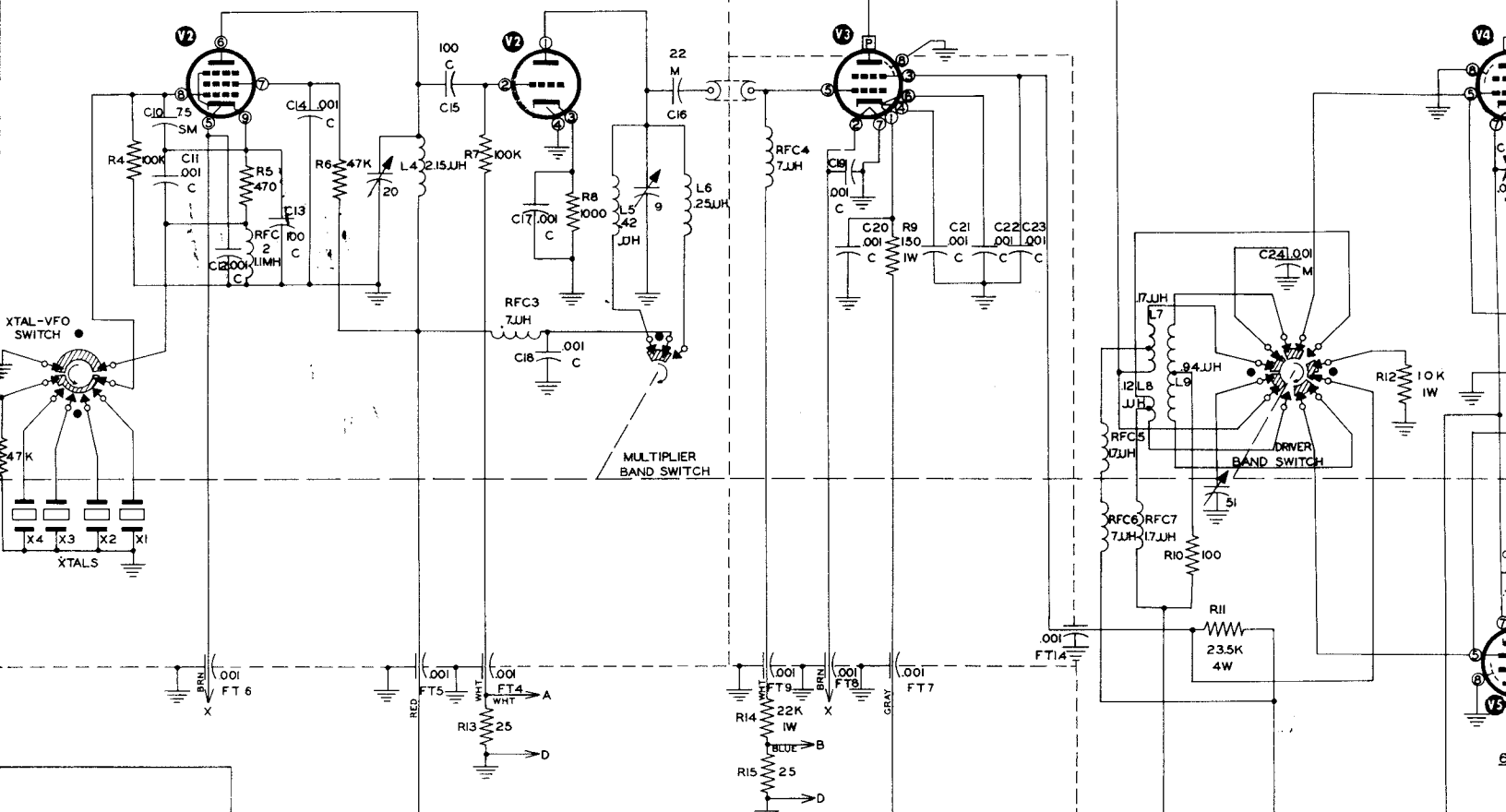

ALL RESISTORS ARE 1/2 WATT UNLESS CAPACITORS MARKED WITH A DECIMAL OTHERS ARE .01μF

CAPACITORS DESIGNATED WITH THE FOLLOWING:

- SM - SILVERED MICA
- C - CERAMIC
- M - MICA
- P - PAPER
- FT - FEED THROUGH

BAND SWITCH SHOWN IN 6 METER POSITION
 XTAL-VFO SWITCH SHOWN IN VFO POSITION
 FUNCTION SWITCH SHOWN IN OFF POSITION

AUXILIARY SOCKET CONNECTIONS:

- PIN 2 - RECEIVER MUTE
- PIN 3 AND 4 - REMOTE CONTROL
- PIN 5 AND 6 - ANT. RELAY (117 VAC)

COLOR CODE MARKING OF LEADS ARE THE CABLE HARNESS ONLY. (EXCLUDING TRACER)

Free Manual

Not to be resold

**Technology
Systems**

**PLEASE REPORT VOILATIONS TO
WWW.TECH-SYSTEMS-LABS.COM**