

**Robin Industrial Engines®**

# **SERVICE MANUAL**

**Models**

**DY30, DY35, DY41,**

1193S115



**ROBIN AMERICA, INC.**  
**ROBIN TO WISCONSIN ROBIN**  
**ENGINE MODEL CROSS REFERENCE LIST**

ROBIN

WISCONSIN ROBIN

SIDE VALVE

EY08	W1-080
EY15	W1-145
EY15V	W1-145V
EY20	W1-185
EY20V	W1-185V
EY23	W1-230
EY28	W1-280
EY35	W1-340
EY40	W1-390
EY45V	W1-450V
EY21	EY21W
EY44	EY44W
EY18-3	EY18-3W
EY25	EY25W
EY27	EY27W

OVERHEAD VALVE

EH11	WO1-115
EH12	WO1-120
EH15	WO1-150
EH17	WO1-170
EH21	WO1-210
EH25	WO1-250
EH30	WO1-300
EH30V	WO1-300V
EH34	WO1-340
EH34V	WO1-340V
EH43V	WO1-430V

TWO CYCLE

EC13V	WT1-125V
-------	----------

DIESEL

DY23	WRD1-230
DY27	WRD1-270
DY30	WRD1-300
DY35	WRD1-350
DY41	WRD1-410

# CONTENTS

<i>Section</i>	<i>Title</i>	<i>Page</i>
<b>1.</b>	<b>SPECIFICATIONS</b> .....	1
<b>2.</b>	<b>PERFORMANCE</b> . . . . .	3
2-1	Maximum Output . . . . .	3
2-2	Continuous Rated Output . . . . .	3
2-3	Maximum Torque and Fuel Consumption Ratio at Maximum Output . . . . .	3
<b>3.</b>	<b>FEATURES</b> . . . . .	5
<b>4.</b>	<b>GENERAL DESCRIPTION of ENGINE CONSTRUCTION</b> . . . . .	5
4-1	Crankcase . . . . .	5
4-2	Crankshaft . . . . .	6
4-3	Connecting Rod and Piston . . . . .	6
4-4	Cylinder and Cylinder Head . . . . .	6
4-5	Gear Case Cover . . . . .	7
4-6	Camshaft . . . . .	7
4-7	Tappet and Tappet Guide . . . . .	7
4-8	Rocker Arm . . . . .	7
4-9	Rocker Cover . . . . .	8
4-10	Governor System . . . . .	8
4-11	Lubrication System . . . . .	8
4-12	Cooling System . . . . .	9
4-13	Injection Pump . . . . .	9
4-14	Nozzle . . . . .	9
4-15	Combustion System . . . . .	10
4-16	Sectional View of Engine . . . . .	11
<b>5.</b>	<b>DISASSEMBLY and REASSEMBLY</b> . . . . .	13
5-1	Preparations and Suggestions . . . . .	13
5-2	Special Tools . . . . .	13
5-3	Disassembly Sequence . . . . .	14
5-4	How to Reassemble . . . . .	20
<b>6.</b>	<b>FUEL</b> . . . . .	28
6-1	Quality of Fuel . . . . .	28
<b>7.</b>	<b>GENERAL DESCRIPTION of AUXILIARY GADGETS and PARTS</b> . . . . .	29
7-1	Fuel Injection Pump Mechanism . . . . .	29
7-2	Fuel Injection Nozzle Holder . . . . .	33
7-3	Governor Mechanism and Operation . . . . .	36
7-4	Lubrication System and Oil Pump . . . . .	38
7-5	Oil Filter . . . . .	38
7-6	Electric Apparatus . . . . .	39
<b>8.</b>	<b>INSTALLATION</b> . . . . .	40
8-1	Installing . . . . .	40
8-2	Ventilation . . . . .	40
8-3	Exhaust Gas Discharge . . . . .	40
8-4	Fuel System . . . . .	40
8-5	Power Transmission to Driven Machines . . . . .	40
<b>9.</b>	<b>CHECKS and CORRECTIONS</b> . . . . .	41
<b>10.</b>	<b>TABLE of CORRECTION STANDARDS</b> . . . . .	42
<b>11.</b>	<b>MAINTENANCE and STORING</b> . . . . .	45
11-1	Daily Checks and Maintenance . . . . .	45
11-2	Every 25 Hours Checks and Maintenance . . . . .	45
11-3	Every 50 Hours (10 days) Checks and Maintenance . . . . .	45
11-4	Every 100 ~ 200 Hours (Monthly) Checks and Maintenance . . . . .	45
11-5	Every 500 ~ 600 Hours (Semiannual) Checks and Maintenance . . . . .	46
11-6	Every 1000 Hours (Yearly) Checks and Maintenance . . . . .	46
11-7	Every 1500 Hours (Overhauls) . . . . .	46
11-8	Preparation for Long Abeyance . . . . .	46
<b>12.</b>	<b>REDUCTIONS for B TYPE ENGINES</b> . . . . .	47
12-1	Configuration of 1/2 Reducer . . . . .	48
12-2	Structure of 1/2 Reducer . . . . .	49
12-3	Disassembly and Reassembly of 1/2 Reducer . . . . .	51

Model	DY30			DY35		
	DY30D	DY30DS	DY30B	DY30BS	DY35D	DY35DS
Type	Air-Cooled, 4-Cycle, Vertical, Overhead Valve, Single Cylinder Diesel Engine					
Bore x Stroke	76 mm x 66 mm (2.99" x 2.60")					
Piston Displacement	299 cc (18.25 cu. inch)					
Compression Ratio	21					
Continuous Rated Output	5 HP/3,000 rpm	5.5 HP/3,600 rpm	5 HP/1,450 rpm	5.5 HP/1,750 rpm	6 HP/3,000 rpm	6.5 HP/3,600 rpm
Maximum Output	6 HP/3,000 rpm	6.5 HP/3,600 rpm	6 HP/1,450 rpm	6.5 HP/1,750 rpm	7 HP/3,000 rpm	7.5 HP/3,600 rpm
Maximum Torque	1.55 kg-m/2,400 rpm					
Rotation	Counterclockwise facing to P.T.O. shaft					
Cooling System	Forced air cooling					
Lubrication	Forced oil lubrication type					
Lubricant	Diesel Engine Oil (Service Rank "CC" or better) SAE #30 . . . . . Ambient temperature: 10°C ~ 40°C SAE 10W30 . . . . . Ambient temperature: -10°C ~ 20°C					
Oil Pump	Trochoid gear type					
Injection Pump	Diesel Kiki K. K. PFRIKD55/2NP1 (Bosch type)					
Injection Nozzle	Diesel Kiki K. K. DLLA150PN000					
Fuel	Diesel light oil					
Fuel Consumption	200 g/HP-h (5 HP/3,000 rpm)	230 g/HP-h (5.5 HP/3,600 rpm)	200 g/HP-h (5 HP/1,450 rpm)	230 g/HP-h (5.5 HP/1,750 rpm)	200 g/HP-h (6 HP/3,000 rpm)	230 g/HP-h (6.5 HP/3,600 rpm)
Fuel Feed	Gravity type					
Fuel Tank Capacity	Approx. 4.5 liters (1.18 U.S. gal.)					
Combustion System	Direct injection type					
Speed Governor	Centrifugal flyweight type					
Lighting Capacity	—	12V-30W	—	12V-30W	—	12V-30W
Starting System	Starting by hand cranking	Electric starter	Starting by hand cranking	Electric starter	Starting by hand cranking	Electric starter
Dry Weight	41 kg (90.4 lbs.)	49 kg (108.0 lbs.)	47 kg (103.6 lbs.)	55 kg (121.2 lbs.)	41.5 kg (91.5 lbs.)	49.5 kg (109.1 lbs.)
Dry Weight with Balancer	42.2 kg (93 lbs.)	50.2 kg (110.7 lbs.)	48.2 kg (106.3 lbs.)	56.2 kg (123.9 lbs.)	42.7 kg (94.1 lbs.)	50.7 kg (111.8 lbs.)
	386 mm (15.2")	386 mm (15.2")	447 mm (17.6")	447 mm (17.6")	386 mm (15.2")	386 mm (15.2")
	370 mm (14.6")	404 mm (15.9")	402 mm (15.8")	404 mm (15.9")	370 mm (14.6")	404 mm (15.9")
Dimensions	450 mm (17.7")	450 mm (17.7")	450 mm (17.7")	450 mm (17.7")	450 mm (17.7")	450 mm (17.7")

Specifications are subject to change without prior notice.

Model	DY35			DY41		
	DY35B	DY35BS	DY41D	DY41DS	DY41B	DY41BS
Type	Air-Cooled, 4-Cycle, Vertical, Overhead Valve, Single Cylinder Diesel Engine					
Bore x Stroke	82 mm x 66 mm (3.23" x 2.60")					
Piston Displacement	348 cc (21.25 cu. inch)					
Compression Ratio	21					
Continuous Rated Output	6 HP/1,450 rpm	6.5 HP/1,750 rpm	7 HP/3,000 rpm	7.5 HP/3,600 rpm	7 HP/1,450 rpm	7.5 HP/1,750 rpm
Maximum Output	7 HP/1,450 rpm	7.5 HP/1,750 rpm	8 HP/3,000 rpm	8.5 HP/3,600 rpm	8 HP/1,450 rpm	8.5 HP/1,750 rpm
Maximum Torque	3.5 kg-m/1,150 rpm					
Rotation	Counterclockwise facing to P.T.O. shaft					
Cooling System	Forced air cooling					
Lubrication	Forced oil lubrication type					
Lubricant	Diesel Engine Oil (Service Rank "CC" or better) SAE #30 ..... Ambient temperature: 10°C ~ 40°C SAE 10W30 ..... Ambient temperature: -10°C ~ 20°C					
Oil Pump	Trochoid gear type					
Injection Pump	Diesel Kiki K. K. PFR1KD55/2NP1 (Bosch type)					
Injection Nozzle	Diesel Kiki K. K. DLLA150PN000					
Fuel	Diesel light oil					
Fuel Consumption	200 g/HP-h (6 HP/1,450 rpm)	230 g/HP-h 6.5 HP/1,750 rpm)	200 g/HP-h (7 HP/3,000 rpm)	230 g/HP-h (7.5 HP/3,600 rpm)	200 g/HP-h (7 HP/1,450 rpm)	230 g/HP-h (7.5 HP/1,750 rpm)
Fuel Feed	Gravity type					
Fuel Tank Capacity	Approx. 4.5 liters (1.18 U.S. gal.)					
Combustion System	Direct injection type					
Speed Governor	Centrifugal flyweight type					
Lighting Capacity	—	12V-30W	—	12V-30W	—	12V-30W
Starting System	Starting by hand cranking	Electric starter	Starting by hand cranking	Electric starter	Starting by hand cranking	Electric starter
Dry Weight	47.5 kg (104.7 lbs.)	55.5 kg (122.3 lbs.)	45 kg (99.2 lbs.)	53 kg (116.8 lbs.)	51 kg (112.4 lbs.)	58 kg (127.9 lbs.)
Dry Weight with Balancer	48.7 kg (107.4 lbs.)	56.7 kg (125 lbs.)	46.5 kg (102.5 lbs.)	55 kg (121.2 lbs.)	52.2 kg (115.7 lbs.)	59.2 kg (130.5 lbs.)
	Length	447 mm (17.6")	447 mm (17.6")	386 mm (15.2")	447 mm (17.6")	447 mm (17.6")
	Width	402 mm (15.8")	404 mm (15.9")	370 mm (14.6")	404 mm (15.9")	402 mm (15.8")
Dimensions	Height	450 mm (17.7")	478 mm (18.8")	478 mm (18.8")	478 mm (18.8")	478 mm (18.8")

Specifications are subject to change without prior notice.

## 2. PERFORMANCE

### 2-1 MAXIMUM OUTPUT

The maximum output of an engine is such standard power as developed by the engine, after its initial break in period with all the moving parts properly worn in, when operating with a fully open injection pump. Therefore, a new engine may not develop the maximum output in the beginning because the moving parts are not in a properly worn-in condition.

### 2-2 CONTINUOUS RATED OUTPUT

The continuous rated output of an engine is such power as developed by that engine when running continuously at an optimum speed, and most favorable from the viewpoint of engine life and fuel consumption ratio, with the governor in operation. It is suggested, therefore, that when designing a driving system for any mechanism, with this engine as prime mover, the continuous power requirement of that mechanism be kept below the continuous rated output specified.

### 2-3 MAXIMUM TORQUE and FUEL CONSUMPTION RATIO AT MAXIMUM OUTPUT

These mean the maximum torque of the output shaft and fuel consumption ratio at the maximum output of an engine.

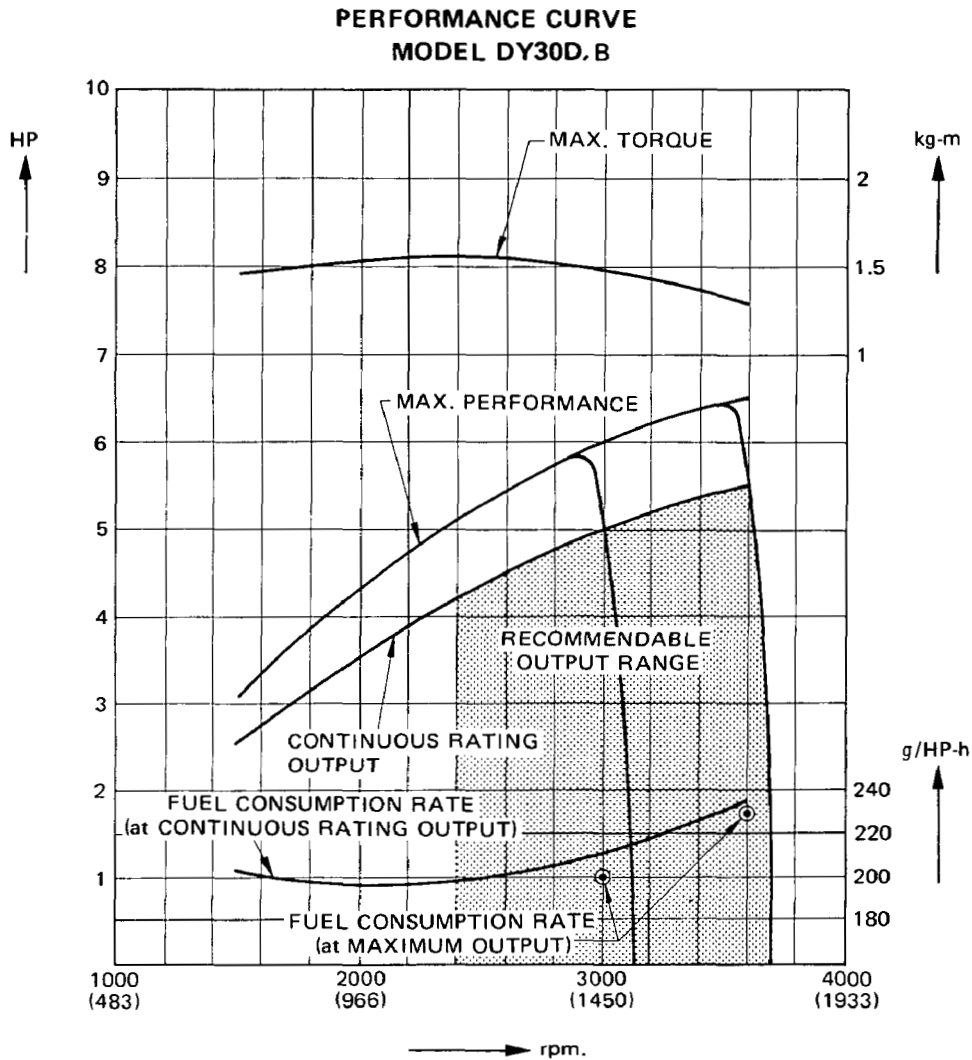

**PERFORMANCE CURVE  
MODEL DY35D,B**

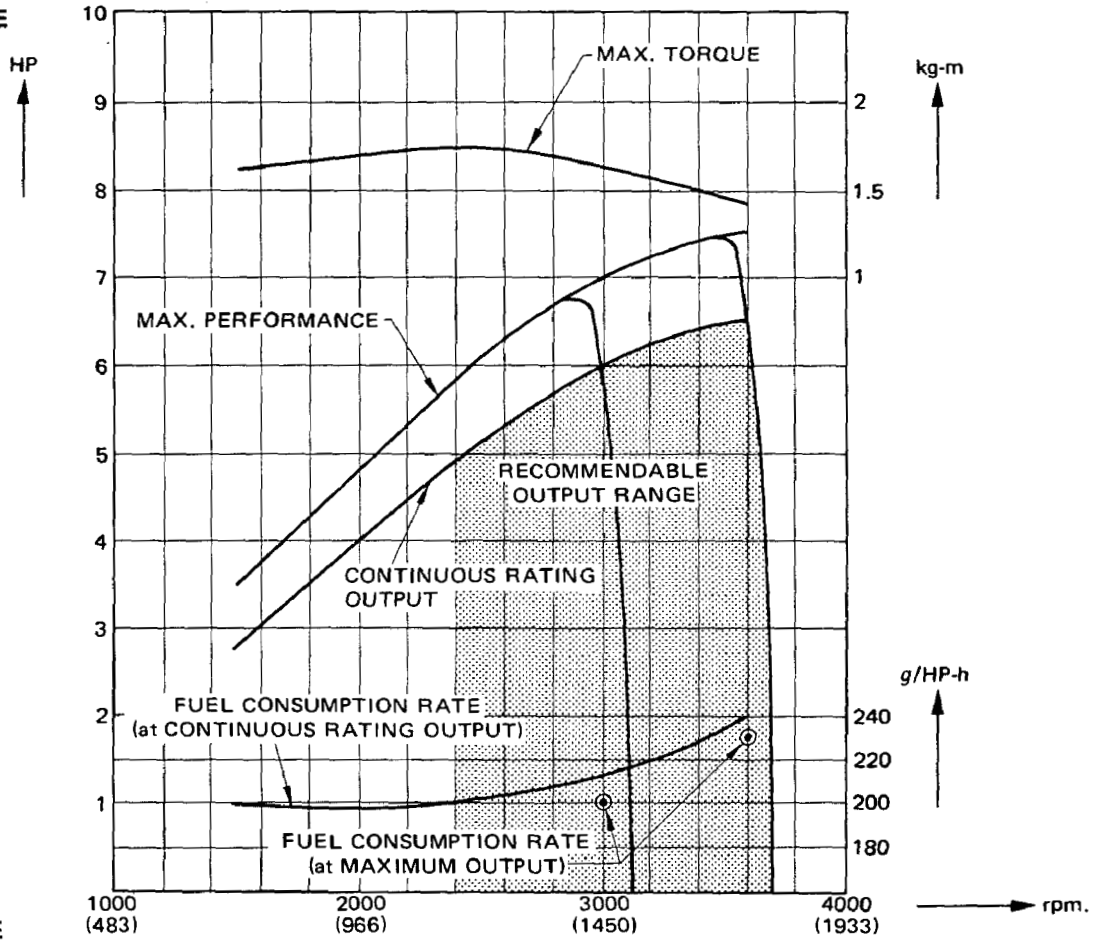

**PERFORMANCE CURVE  
MODEL DY41D,B**

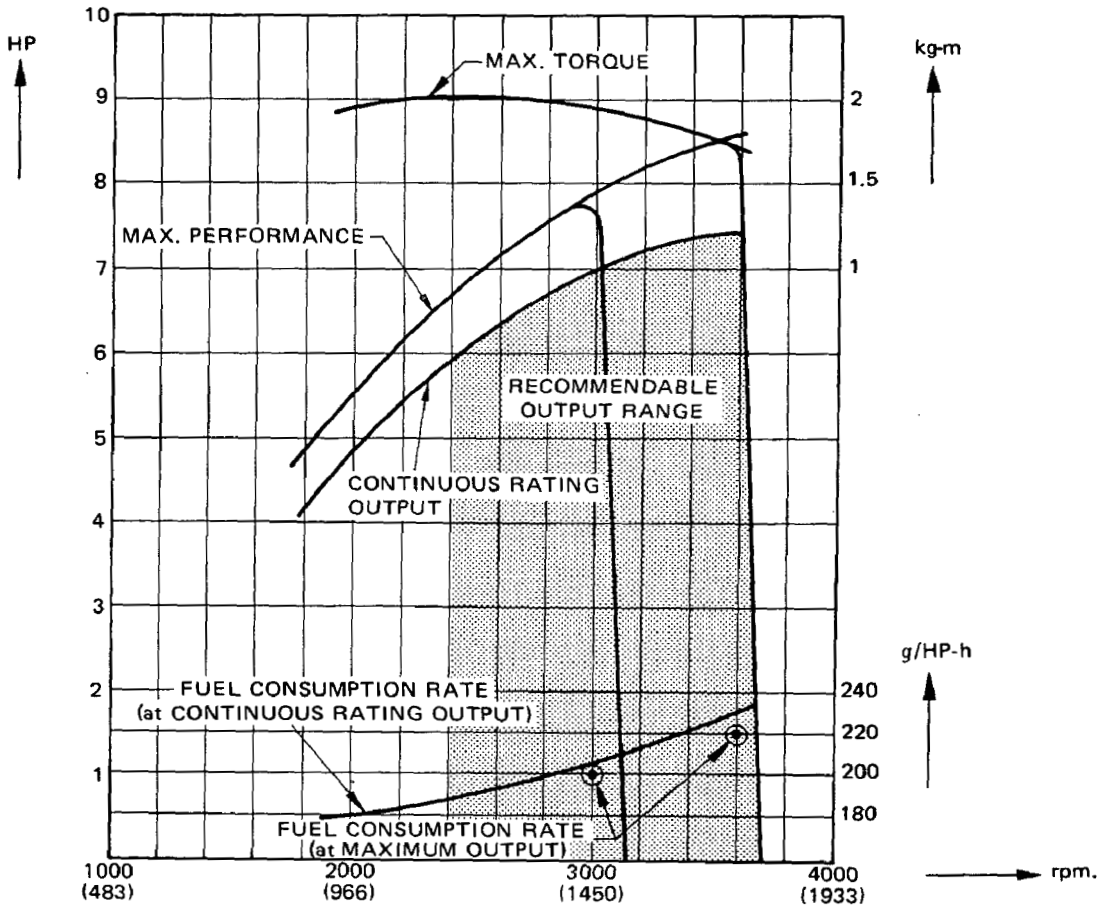

### 3. FEATURES

#### LIGHTWEIGHT and COMPACT

1. Lightweight because of aluminum alloy being used for various parts including the crankcase made of aluminum die casting
2. Compact in outside dimensions because—
  - a) the camshaft is assembled inside of the gear case cover, and accordingly total width of the engine is reduced,
  - b) the cooling fan and the flywheel are single piece die casting; and the cooling fan is set on the side of the case so that it may breathe in cooling air from the front, which means that the size of the fan casing becomes smaller and total length of the engine is also reduced.

#### FUEL ECONOMY and NOISELESS TYPE ENGINE

Low fuel consumption owing to improved fuel combustion system having adopted direct fuel injection; and noiseless operation owing to the highly effective muffler and air cleaner

As an optional part a balancer is available for minimizing vibration.

#### EASY to TAKE-OUT POWER

A faucet joint is set in the blower housing, which enables direct coupling with a machine. P.T.O. shaft is connected to the flywheel and accordingly this engine is very easy to handle. Furthermore, as cooling air is taken into from the front of case (reverse side of the machine coupled), it is unnecessary to arrange air-intake on the side of the machine. Therefore, it is easy to couple a machine to the engine.

### 4. GENERAL DESCRIPTION of ENGINE CONSTRUCTION

This engine is a Forced Air Cooled, 4-Cycle, Vertical, Single Cylinder, Overhead Valve Diesel Engine, and the combustion system is direct injection type.

#### 4-1 CRANKCASE

The crankcase is made of a one-piece aluminum alloy die casting. On the side of pump, bearing is press-fitted; and on the fan side cast iron bearing housing is arranged, and it supports the crankshaft by a ball bearing press-fitted to the shaft. Also, on the fan side, blower housing of aluminum die casting is fitted. This blower housing has a faucet joint and it enables direct coupling with a machine. (See Fig. 1.)

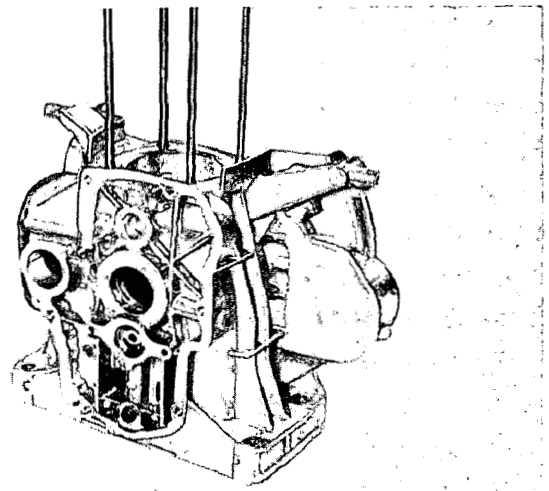

Fig. 1



## 4-2 CRANKSHAFT

The crankshaft is made of a forged chrome and molybdenic steel piece with the crank pins and the journals ground to high precision after induction hardening. It is fitted to the flywheel on the fan side, and connection of the drive shaft to it is also possible. In the center of the pins and the journals, holes for forced lubrication are drilled through.

(See Fig. 2.)

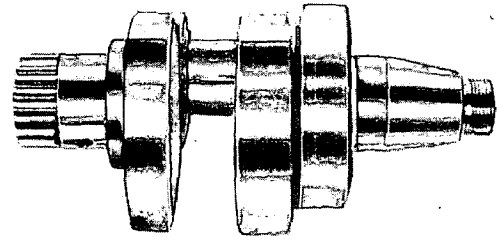

Fig. 2

## 4-3 CONNECTING ROD and PISTON

### 4-3-1 CONNECTING ROD

The connecting rod is made of forged pieces of aluminum alloy designed with sufficient strength to withstand buckling and tensile forces inflicted on it under high-load operating conditions. At the small end a bushing is forcefitted to withstand the pressure resultant from pitching during high-speed operation. At the larger end thin kelmet is fitted for increasing durability.

### 4-3-2 PISTON

Piston is made of cast aluminum alloy, and it has two compression rings and an oil ring. Combustion chamber arranged at the piston head, where combustion gas is made up by mixing atomized fuel and air, and ignites. (See Fig. 3.)

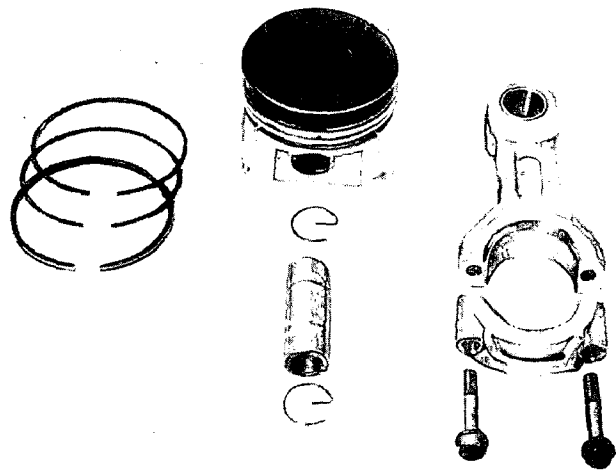

Fig. 3

## 4-4 CYLINDER and CYLINDERHEAD

### 4-4-1 CYLINDER

Cylinder is made of aluminum alloy die casting, in which special cast iron liner is cast, and is provided with many cooling fins designed for effective cooling.

### 4-4-2 CYLINDERHEAD

The most important part of the diesel engine is cylinderhead. It is a one-piece of aluminum alloy die casting, in which intake and exhaust ports, and rocker chamber are cast in the most ideal structure for the highest strength and the highest cooling efficiency. In the valve seats fine quality heat resistance seats are pressure-fitted considering high resistance to abrasion and corrosion at high temperature. (See Fig. 4.)

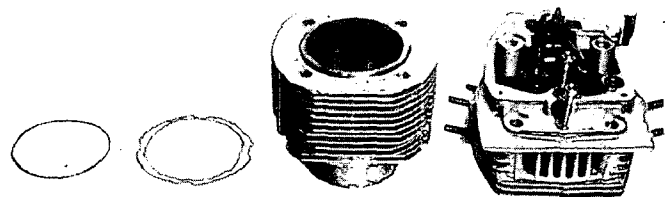

Fig. 4

#### 4-5 GEARCASE COVER

Gearcase cover is made of aluminum alloy die casting and is fitted on the reverse side of the flywheel. This cover embraces the injection pump, timing gear, operating lever and supports the camshaft as a bearing. To the gear case cover the tappet guide is fitted and then the tappets are assembled. (See Fig. 5.)

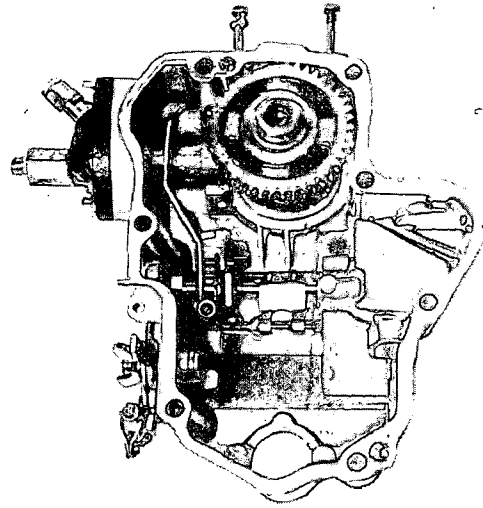

Fig. 5

#### 4-6 CAMSHAFT

The camshaft is made of forged chrome steel wholly sintered and then ground. It carries three cams, viz. one intake cam, one exhaust cam, and one fuel injection pump cam, and the shaft is supported by a ball bearing pressure-fitted in the gear case cover and by the gear case. The camshaft is assembled inside the gear case cover. To the shaft the relief valve and a pin are fitted. The pin is used when starting engine by hand cranking. (See Fig. 6.)

#### 4-7 TAPPET and TAPPET GUIDE

##### 4-7-1 TAPPET

Tappet is made of forged steel and wholly sintered, ground, and then tafride finished. The camshaft has oil holes for lubricating tappets.

##### 4-7-2 TAPPET GUIDE

Tappet guide is made of aluminum alloy die casting and determines tappet positions and is fitted to the gear case cover. In the crankcase there is a blow-by gas hole, which hole goes through up till rocker chamber via push rod sleeve. (See Fig. 6.)

#### 4-8 ROCKER ARM

Rocker arm is made of forged steel and is wholly sintered and then ground, and it is supported by the rocker shaft. At the one end it has valve clearance adjusting screw. With this screw valve clearance is adjusted to the specified gap and is fixed by lock nut. Lubrication of the rocker arm is carried out by the oil splash contained in the blow-by gas from the crankcase. Intake rocker arm has decompression mechanism. (See Fig. 6.)

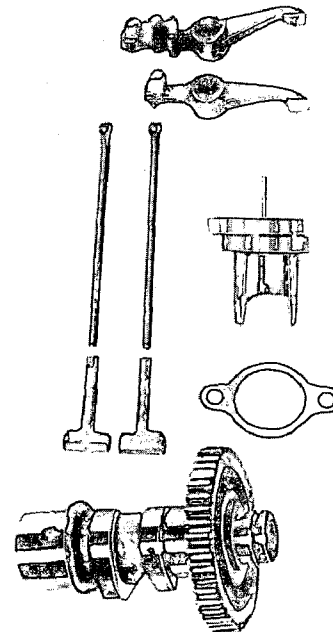

Fig. 6

#### 4-9 ROCKER COVER

Rocker cover is made of aluminum alloy die casting and it is fitted to the cylinderhead and covers the rocker chamber. Rocker cover has a breather; and the air breathed is brought to the intake port.

(See Fig. 7.)

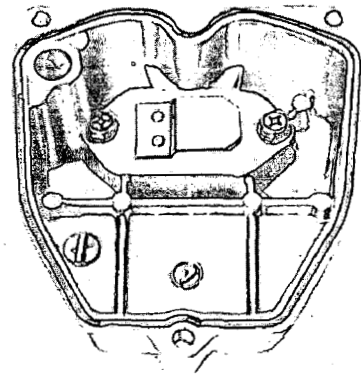

Fig. 7

#### 4-10 GOVERNOR SYSTEM

The governor is a centrifugal flyweight type and is installed on the governor gear. Through the lever it adjusts the rack of fuel injection pump and keeps constant operation at the selected speed against load variations.

(See Fig. 8.)

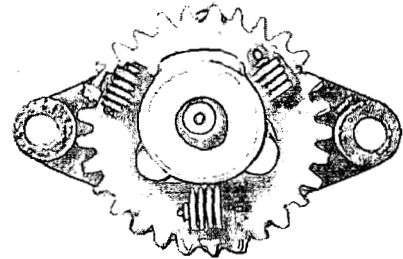

Fig. 8

#### 4-11 LUBRICATION SYSTEM

Lubrication is wholly filtered and pressurized lubrication system by trochoid type oil pump. From the main gallery in the crankcase the pressurized oil runs through the crank journals and crankpins, and from the larger part of the rod the oil is supplied in the form of splash to the parts necessary to be lubricated, while part of the oil also runs through the bearings of camshaft to lubricate both intake and exhaust cams, and tappets. This system includes the governor gears and it is installed in the crankcase.

(See Fig. 9.)

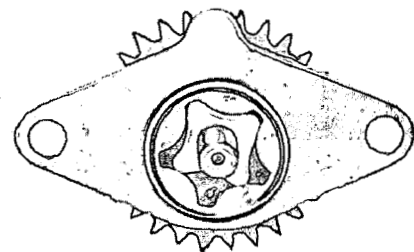

Fig. 9

#### 4-12 COOLING SYSTEM

The cooling fan and the flywheel are a single piece casting and it is fitted to the top end of the crankshaft. Cooling air produced by this fan blows through blower housing and cylinder baffle, and cools cylinder and cylinderhead.

(See Fig. 10.)

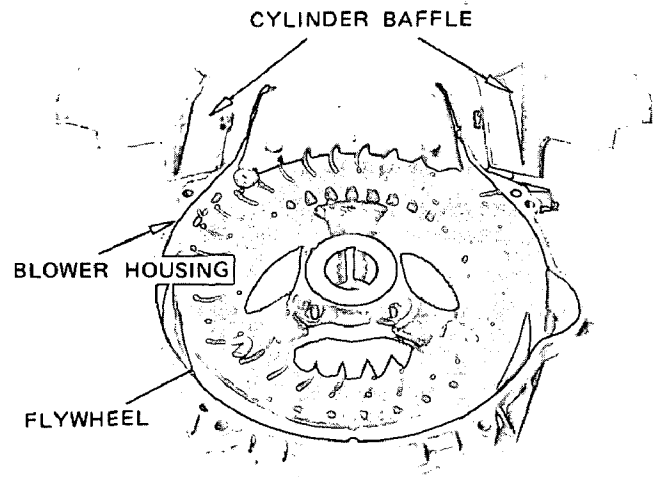

Fig. 10

#### 4-13 INJECTION PUMP

The plunger of the fuel injection pump is operated by the injection pump cam, and the fuel from the tank is pressurized in the pump and supplied to the nozzle via the high pressure pipe.

(See Fig. 11.)

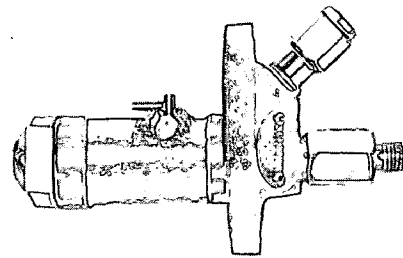

Fig. 11

#### 4-14 NOZZLE

Into the combustion chamber the nozzle injects the pressurized fuel supplied from the pump through the high pressure pipe.

(See Fig. 12.)

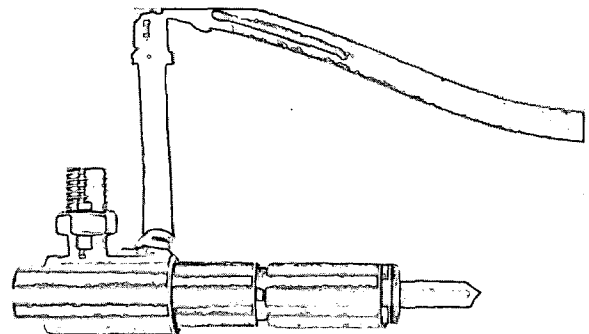

Fig. 12

## 4-15 COMBUSTION SYSTEM

For lower fuel consumption and easy starting of the engine, the direct injection system is adopted in the combustion chamber.

### 4-15-1 FORMING of COMBUSTION GAS and COMBUSTION

#### 1) SWIRL (Inspiring swirl)

In order to promote mixing injected fuel and air under the direct injection system, swirl flow is utilized for good combustion. Swirl is spiral flow of air generated in the cylinder during inspiring stroke, and it decreases during compressing stroke but it still remains and promotes mixing of fuel and air toward ignition timing. Spiral flow of air (swirl) is generated by the shape of intake port, which is called helical port or spiral port. Tail end of intake port, i.e. upper part of intake valve seat, is made in the spiral form; and while the inspired air is passing through this part, swirl is generated around the intake valve. Thus, intake port plays an important role in generating swirl. (See Fig. 13.)

#### 2) SQUISH (Squished air flow)

In the piston, combustion chamber (dish type combustion chamber) is formed. When the piston comes up to TDC (top dead center), air in the gaps is squished in the combustion chamber and air flow is generated, which is called "squish." (See Fig. 14.)

#### 3) FORMING of COMBUSTION GAS and COMBUSTION

For igniting quickly the fuel injected from the nozzle, it is essential to atomize very fine oil particles for distributing evenly in the combustion chamber. For this purpose, fuel should be injected through hole type nozzle by very high pressure, i. e.  $195 \text{ kg/cm}^2$ . The fuel, thus injected, is mixed with air by the flow of swirl and squish while piston is coming up. Accompanying crimb of the piston, combustion gas compressed further and finally it automatically begins igniting and while piston is going down, "squish" functions and promotes combustion.

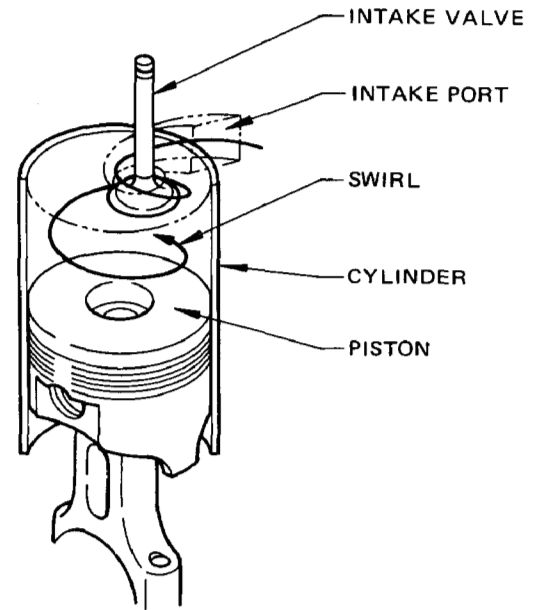

Fig. 13

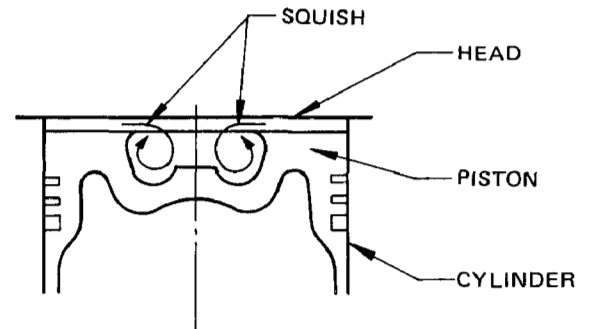
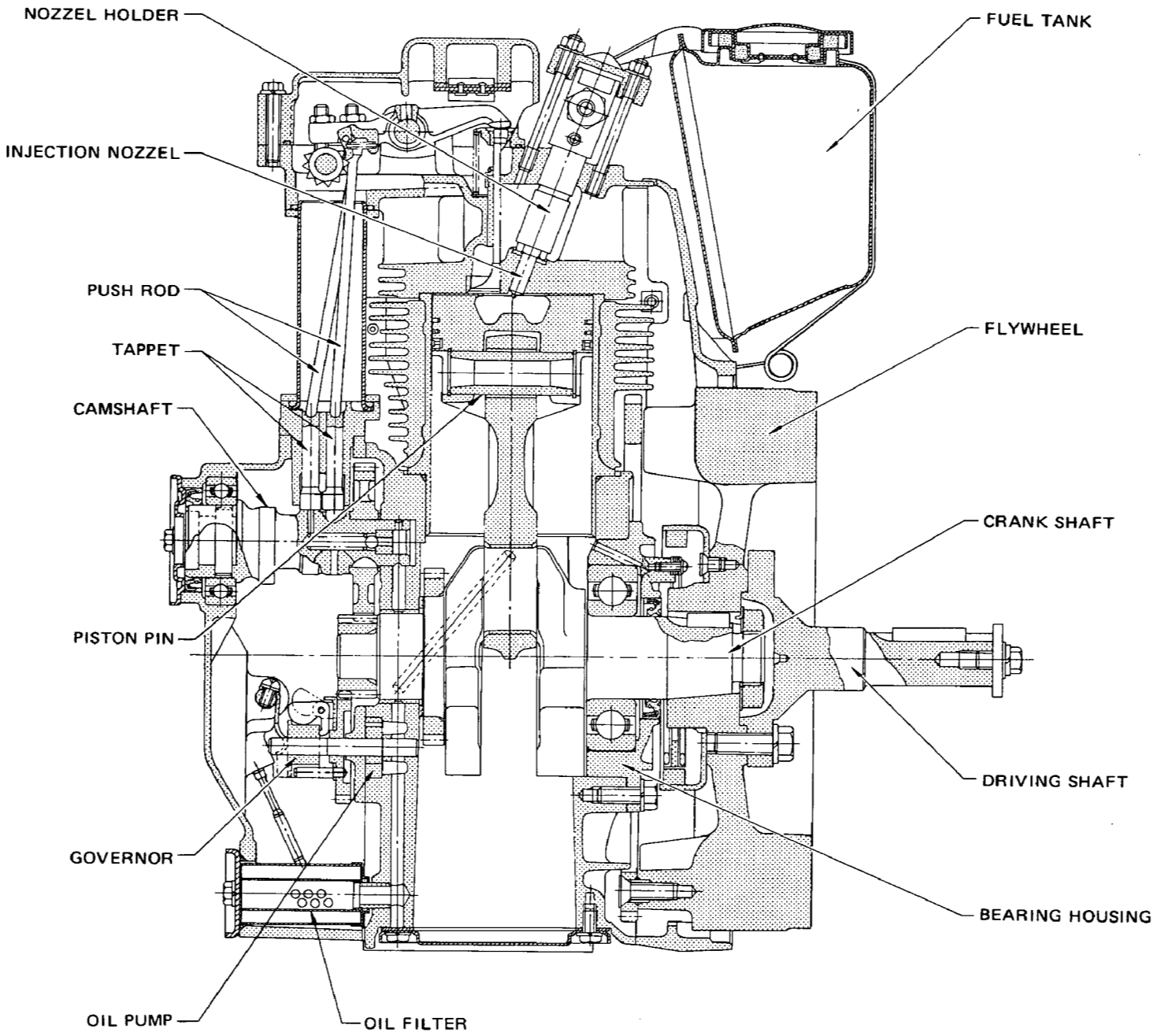
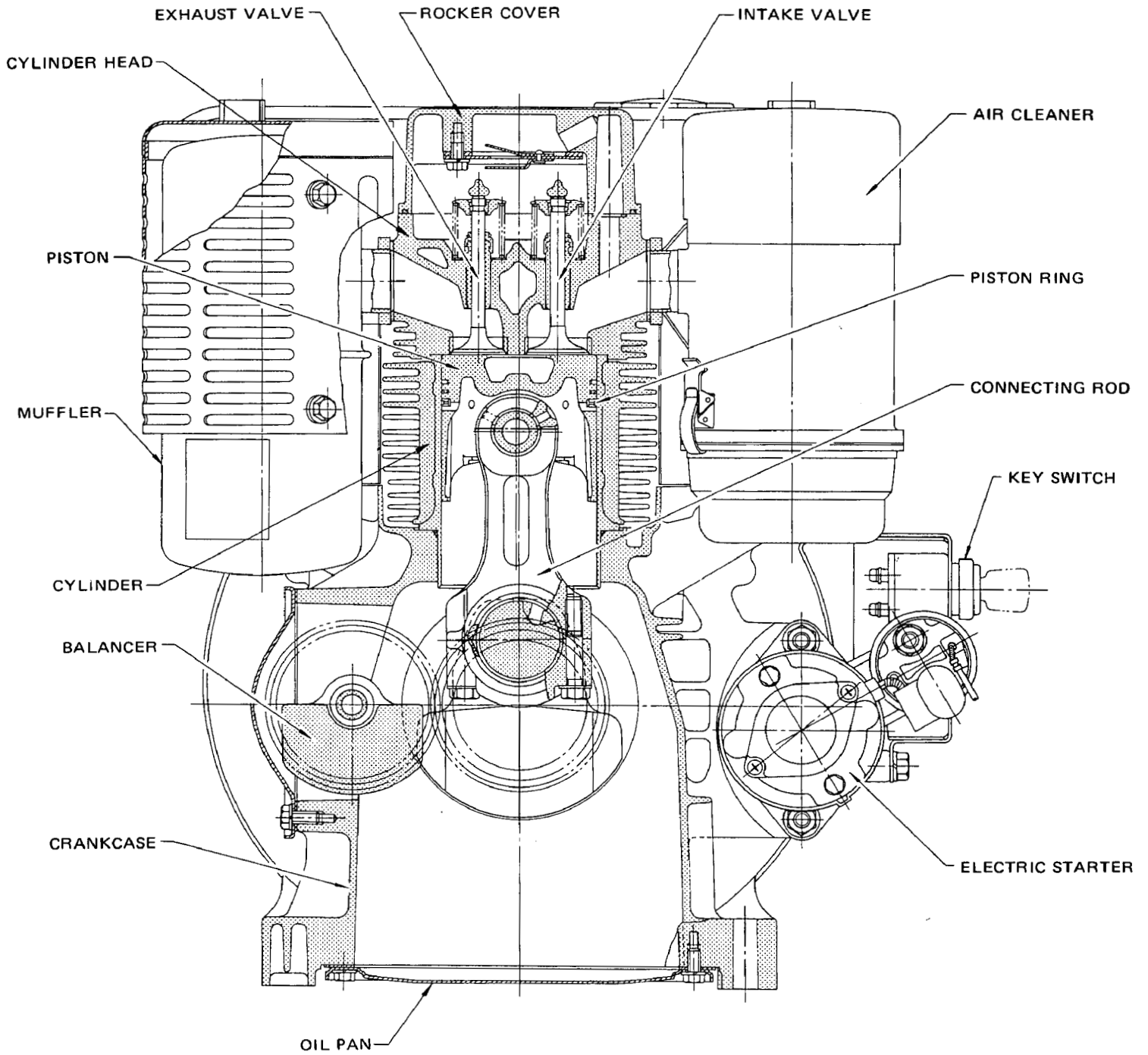

Fig. 14

4-16 SECTIONAL VIEW of ENGINE





## 5. DISASSEMBLY and REASSEMBLY

### 5-1 PREPARATIONS and SUGGESTIONS

- 1) When disassembling the engine, remember well the locations of individual parts so that they can be reassembled correctly. If you are uncertain of identifying some parts, it is suggested that tags should be attached to them.
- 2) Have boxes ready to keep disassembled parts by group.
- 3) To prevent missing and misplacing, temporarily assemble as much as possible each group or set of disassembled small parts such as bolts and nuts, etc.
- 4) Carefully handle disassembled parts, and clean them with washing oil.
- 5) Use the correct tools in the correct way.

### 5-2 SPECIAL TOOLS

Tool No.	Tool	Use
228 95001 07	Flywheel puller with bolt	For pulling off the flywheel
228 95002 07	Box wrench	For removing or fastening the flywheel nut
228 95003 07	Piston ring expander	For placing piston ring

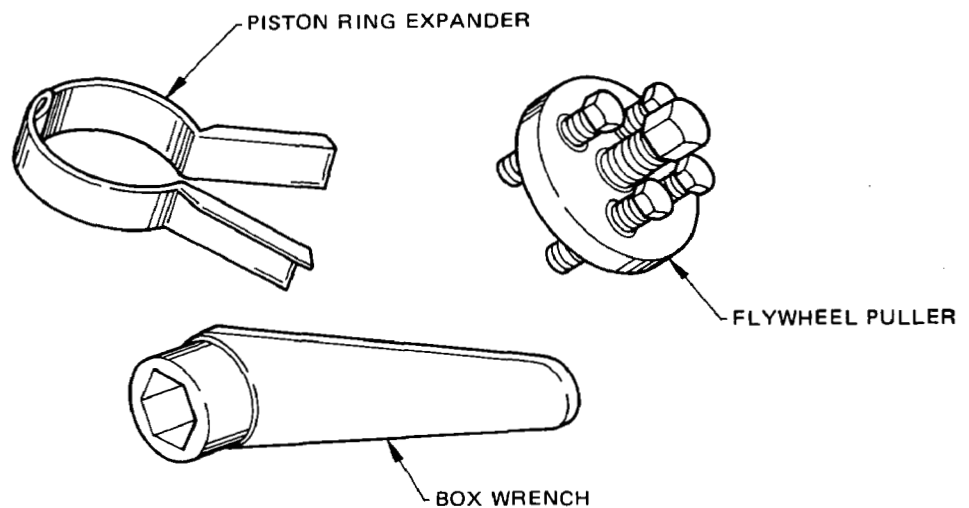

Fig. 15



### 5-3 DISASSEMBLING SEQUENCE

\*Length of the bolt indicates the length from the bolt head bottom surface to the threaded end.

\*\*SW → Spring water

\*\*\*W → Plain washer

Se- quence	Item	Procedures	Remarks	Bolts, nuts etc. used
1	Engine oil	Remove the oil drain plug and discharge oil. Oil drain plug locates under the gear case cover. (Remove oil filter.)	Be sure not to miss the "O" ring. The drain plug serves as an oil filter too. (See Fig. 16.)	6 mm hex. bolt . . . 2 pcs. SW . . . 2 pcs.
2	Fuel	Discharge fuel from the tank. Fuel pipe locates on the side of injection pump.	Be sure not to miss the gasket. (See Fig. 17.)	17 mm hex. bolt . . . 1 pce.
3	Fuel tank	Remove the fuel pipe.	Remove the banjo bolt on the side of the tank. There are 2 sheets of aluminum gasket.	8 x 18 banjo bolt . . . 1 pce.
		Remove the fuel return pipe.	There are 2 sheets of aluminum gasket.	
		Remove the tank band.		6 x 45 round head cross recess bolt . . . 2 pcs. No SW, W
4	Muffler	Remove the muffler cover.		6 x 8 mm flange bolt . . . 4 pcs.
		Remove the muffler.	Be sure not to miss the gasket.	
5	High pressure pipe	Remove the high pressure pipe on the side of injection pump and the nozzle.	Be careful to keep the inside of the pipe, pump, joint of nozzle free of dust.	12 mm nut . . . 2 pcs.
6	Air cleaner	Remove the air cleaner from the cylinder head.	The gasket is same as that of the muffler.	8 mm nut . . . 2 pcs. SW . . . 2 pcs.
7	Tank bracket	Remove the bracket from the crankcase, left and right, each.	Just loosen 8 mm nut.	8 x 16 7T bolt . . . 2 pcs.

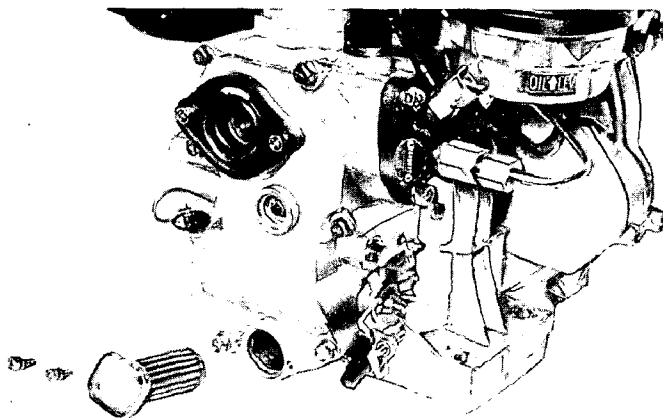

Fig. 16

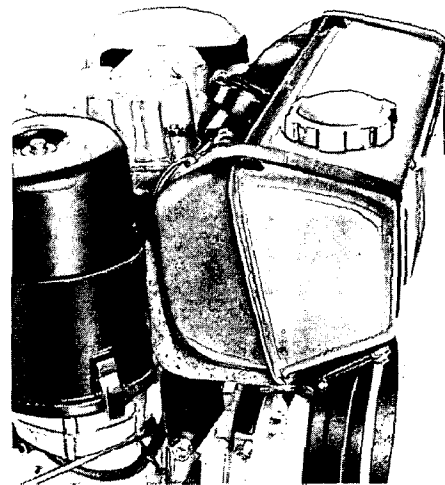

Fig. 17

Se- quence	Item	Procedures	Remarks	Bolts, nuts etc. used
8	Flywheel	Remove the flywheel cover. Remove the driving shaft.  Raise up lock washer, loosen lock nut (41 mm box spanner) and then remove the flywheel from the crankshaft using the flywheel puller.	Crankshaft, normal threading (See Fig. 18.)	8 x 16 4T bolt . . . 4 pcs. 10 x 30 bolt . . . 4 pcs.
9	Blower housing	Remove the blower housing from the crankcase.	Just loosen the flange bolts.	6 x 8 flange bolt . . . 2 pcs. No W. 8 x 55 7T bolt . . . 2 pcs. SW . . . 2 pcs. 8 x 40 7T bolt . . . 2 pcs. SW . . . 2 pcs.
10	Cylinder baffle	Remove the cylinder baffle from the cylinder.	Be sure not to miss 5 mm nut.	5 x 10 round head cross recess screw . . . 1 pce.
11	Rocker cover	Remove the rocker cover from the cylinderhead.		6 x 35 7T bolt . . . 3 pcs. SW . . . 3 pcs.
12	Nozzle holder	Remove the nozzle holder from the cylinderhead.	At the top end the gasket is fitted.	6 mm nut . . . 2 pcs. SW . . . 2 pcs.
13	Rocker arm	Loosen the nuts fastening the cylinderhead.  Pull out the rocker shaft from the cylinderhead and remove the rocker arm.	Loosen the tappet adjusting bolt and the decompression adjusting bolt, which latter is on the side of the intake valve. (See Fig. 19.)	
14	Cylinderhead	Loosen 6 mm nut which is fastening the push rod sleeve on the side of cylinderhead. Pull out the push rod.	Just loosen 6 mm nut.	6 mm nut . . . 2 pcs.

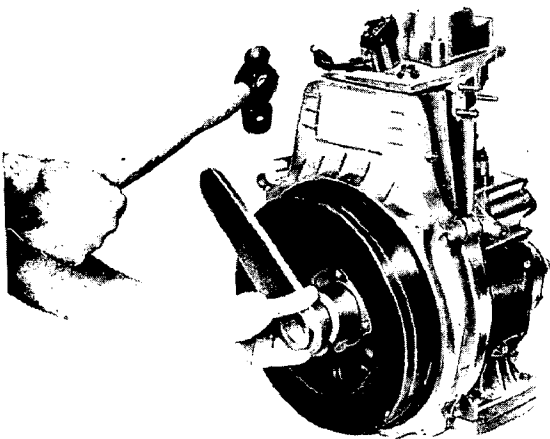

Fig. 18

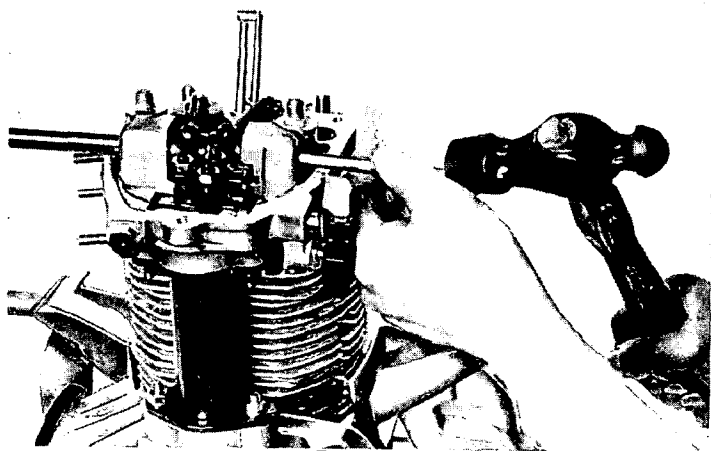

Fig. 19

Se- quence	Item	Procedures	Remarks	Bolts, nuts etc. used
15	Cylinder	Remove the cylinder.	Under the cylinder, there are rubber "O" ring and copper shim. (See Fig. 20.)	10 mm flange nut . . . 4 pcs.
16	Push rod sleeve	Remove the push rod sleeve from the gear case cover.		6 mm nut . . . 2 pcs. SW . . . 2 pcs.
17	Tappet guide	Remove the tappet guide from the gear case cover.	A holder is necessary for not let fall the tappet. (See Fig. 21.)	
18	Injection pump	Remove oil filler cap. Put the control rack at the center.  Remove the injection pump from the gear case cover.	Check the position of control rack. (See Fig. 22.)	8 mm nut . . . 3 pcs. SW . . . 3 pcs.
19	Gear case	Remove the handle guide.  Remove the gear case cover from the crankcase.	(See Fig. 23.)	6 x 6 hex. bolt . . . 2 pcs. SW . . . 2 pcs. 8 x 35 7T bolt . . . 4 pcs. 8 x 80 7T bolt . . . 3 pcs. SW . . . 3 pcs.

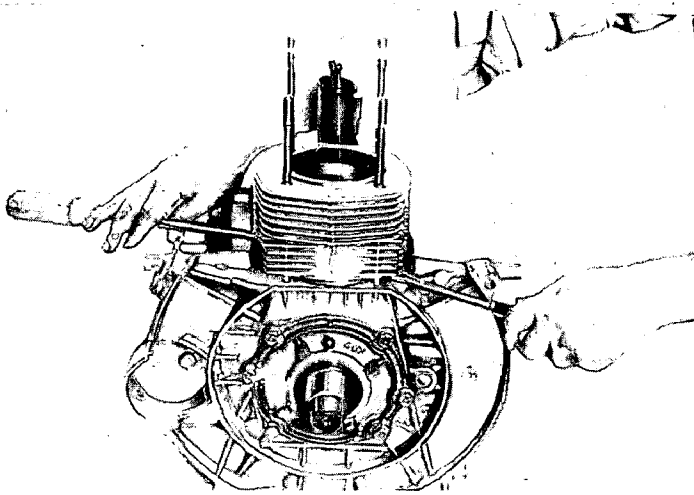

Fig. 20

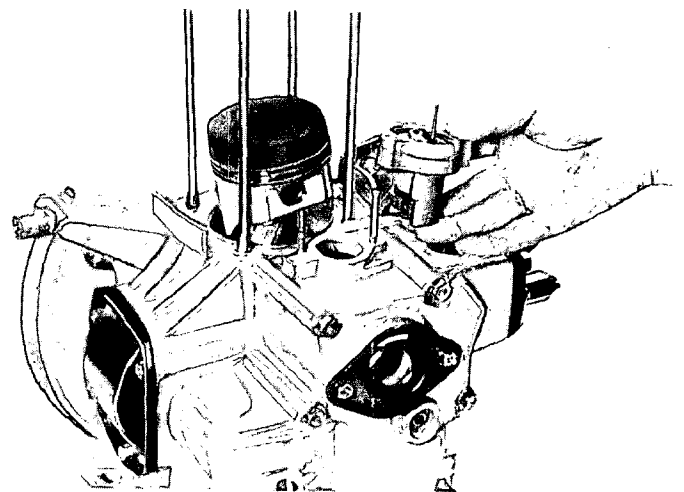

Fig. 21

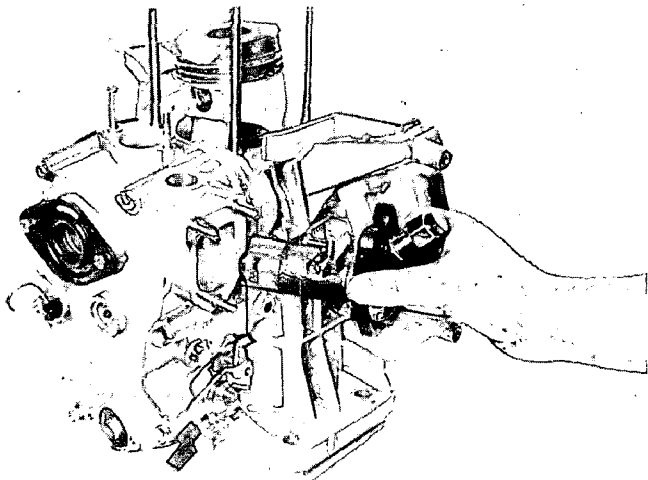

Fig. 22

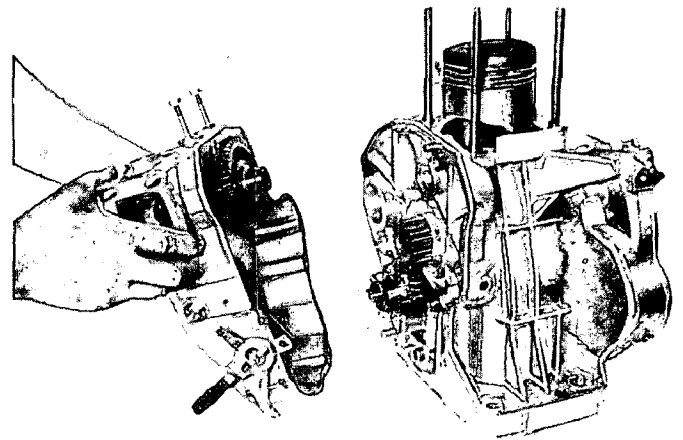

Fig. 23

Se- quence	Item	Procedures	Remarks	Bolts, nuts etc. used
20	Camshaft	Pull out the camshaft.	Between camshaft and gear case there is a shim. (See Fig. 24.)	
21	Piston	Remove the piston from the connecting rod. (Remove the clip and pull out the piston.)	Watch the direction of the clip, also pay attention to the direction of the piston. (→ mark indicates "toward the fan side.") (See Fig. 25.)	
22	Governor and oil pump	From the crankcase remove the governor and oil pump in the form of one piece.		6 x 20 7T bolt . . . 2 pcs. SW . . . 2 pcs.
23	Oil pan	Remove the oil pan from the crankcase.	Be careful of the packings.	6 x 12 bolt . . . 8 pcs. SW . . . 8 pcs.

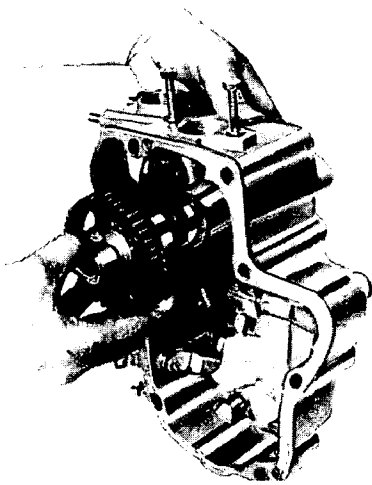

Fig. 24

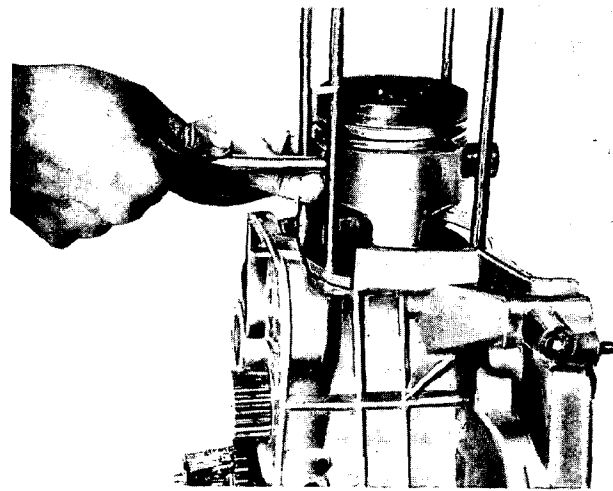

Fig. 25

Se- quence	Item	Procedures	Remarks	Bolts, nuts etc. used
24	Connecting rod	Remove the connecting rod from the crankshaft.	No lock washer. Be careful of the direction of rod. (Fan mark is on the side of the flywheel.) Be careful of the setting mark of the cap. (See Fig. 26.)	
25	Bearing housing and crankshaft	From the crankshaft remove the key on the side of fan.	Be careful of the copper shim and "O" ring between the bearing housing and the case.	8 x 22 7T bolt . . . 6 pcs. SW . . . 6 pcs.
		Remove the bolt fastening the bearing housing.	Also be careful of the hole for oil.	
		Pull the crankshaft together with the bearing housing. (Gently tap the side of crank gear with plastic hammer.)	After pulling out the crankshaft from the case, remove housing.  The bearing remains on the crankshaft. (See Figs. 27, 28 and 29.)	

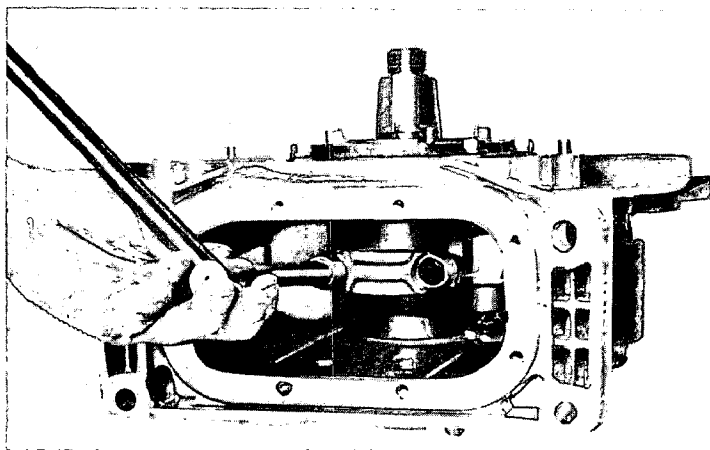

Fig. 26

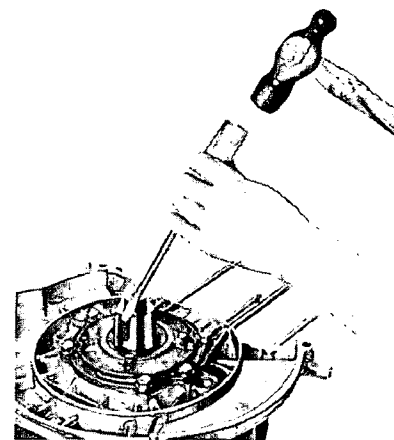

Fig. 27

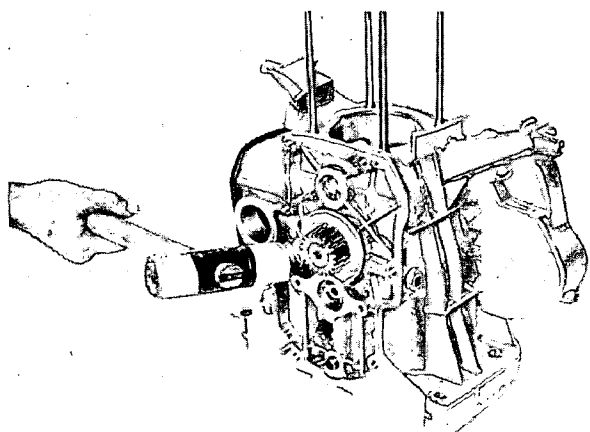

Fig. 28

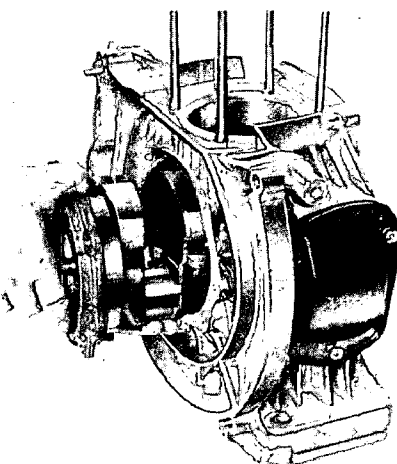

Fig. 29

Se-quence	Item	Procedures	Remarks	Bolts, nuts etc. used
26	Intake and exhaust valve	Remove the intake and exhaust valves from the cylinderhead.	On the side of intake valve, there is a stem seal. Be sure not to miss retainer lock. (See Fig. 30.)	

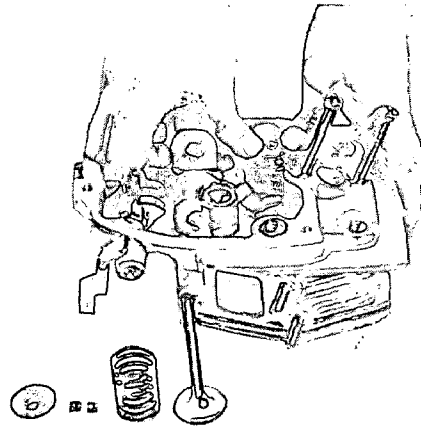

Fig. 30

⊙In case of the engine with the balancer, disassembling sequences after “Sequence No.25 – Pulling out the crankshaft” are as follows.

Se-quence	Item	Procedures	Remarks	Bolts, nuts etc. used
1	Snap ring	Remove the snap ring.	Be sure not to miss the snap ring. (See Fig. 31.)	
2	Balancer shaft	Remove the balancer shaft.	Gently tap with plastic hammer.	
3	Balancer	Remove the balancer from the case.	Be careful not to damage the thrust metal on the side of the pump. The gear and the needle bearing are in one piece. (See Fig. 32.)	

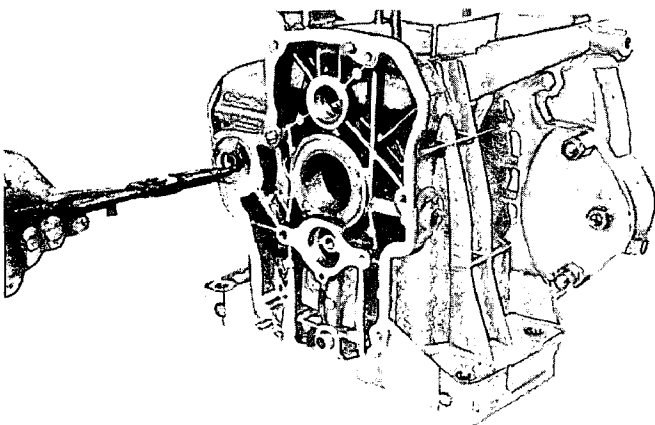

Fig. 31

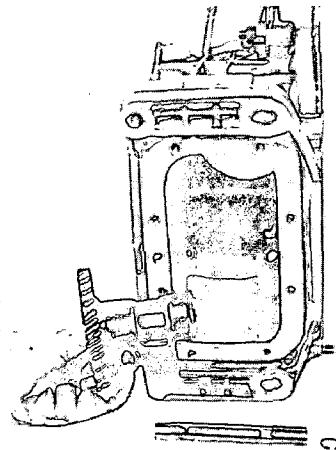

Fig. 32

## 5-4 HOW TO REASSEMBLE

### 1. PRECAUTION IN REASSEMBLING

- 1) Every and each part should be cleaned thoroughly. Especially, pay utmost care and attention to the cleanliness of the piston, cylinder, crankshaft, connecting rod and bearings.
- 2) Scrape completely off carbons from the cylinder head and the upper part of the piston; especially the carbon adhered in the groove of the piston ring should be carefully and completely taken out.
- 3) Carefully check the lip portion of every oil seal. If faulty one is found, replace it without slight hesitation.
- 4) Replace all the gaskets with new ones.
- 5) Replace the key, pin, bolt, nuts, etc. with new one, if necessary.
- 6) Whenever tightening torque is specified, conform to the specified figures.
- 7) Apply oil to the revolutionary parts and friction surfaces, when reassembling.
- 8) Check and adjust the clearances of variouts portions and then reassemble.
- 9) When some main portions are assembled in the course of reassembling, turn or move the gadgets by hand and pay attention to the frictional noise and resistance.

### 2. REASSEMBLING

- 1) Insert the crankshaft into the crankcase.

**CAUTION:** Be careful not to damage bearing metal on the side of injection pipe.

For the engine with the balancer, fit the balancer first to the crankshaft, and then put it into the crankcase.

**CAUTION:** When fitting, check the match mark.

(See Fig. 33.)

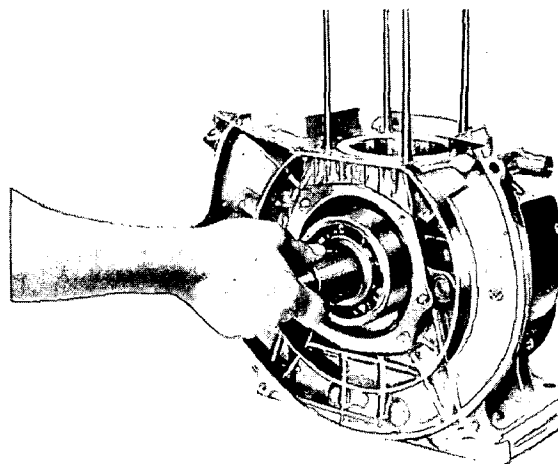

Fig. 33

- 2) Assemble the bearing housing.

8 x 22 7T bolt . . . . . 6 pcs.

Spring washer . . . . . 6 pcs.

**NOTE:** Apply oil or grease inside the housing oil seal.

**CAUTION:** Be sure to put "O" ring on.

**NOTE:** Set the bearing housing so that its oil hole may face upward.

(See Fig. 34.)

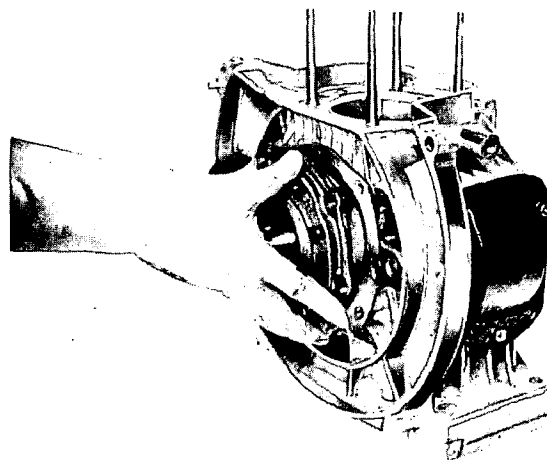

Fig. 34

**NOTE:** With the copper shim adjust the side clearance of the crankshaft be 0.1 ~ 0.2 mm.

Three kinds of shim are available, viz. 0.1 mm, 0.2 mm, and 0.3 mm thick.

[Tightening torque: 200 ~ 230 kg-cm]

(See Fig. 35.)

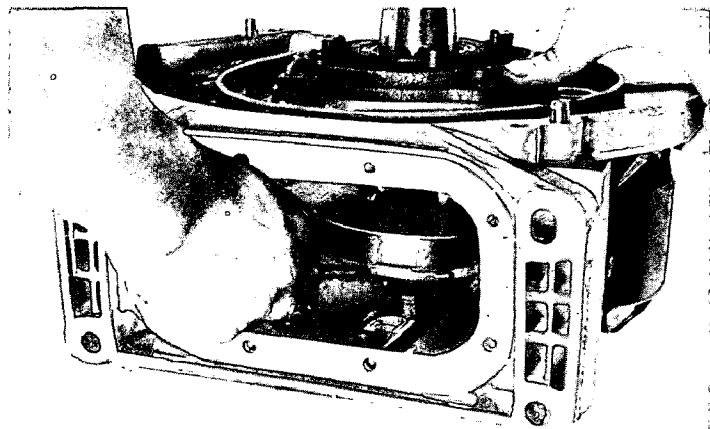

Fig. 35

3) Assemble the connecting rod.

**CAUTION:** Pay attention to the direction of the rod.

(FAN mark is to be set on the side of the flywheel.)

**NOTE:** Check the match mark on the cap.

**NOTE:** The lock washer is not used when fastening the bolt. [Tightening torque: 250 ~ 270 kg-cm]

(See Fig. 36.)

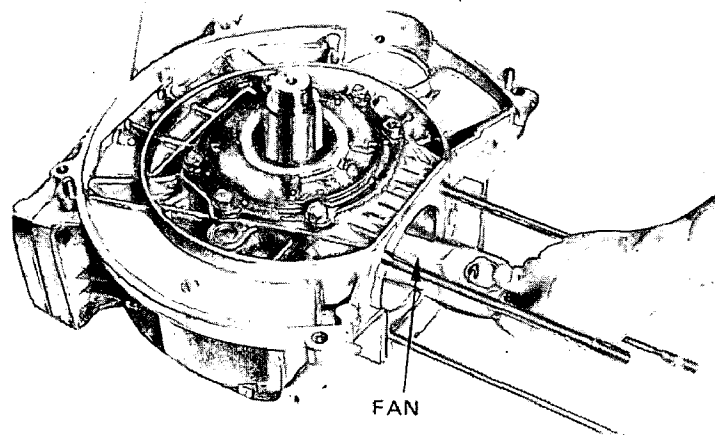

Fig. 36

4) Assemble the oil pan.

6 x 12 bolt . . . . . 8 pcs.

Spring washer . . . . . 8 pcs.

**NOTE:** Pay attention to the packings.

(See Fig. 37.)

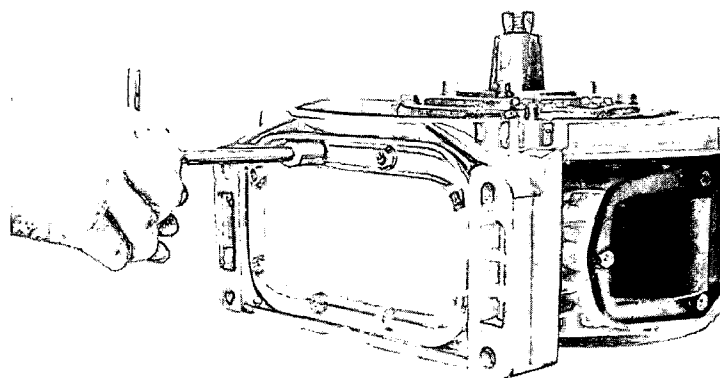



Fig. 37



5) Assemble the piston.

**NOTE:** → mark in the upper part of the piston is to be faced to the fan side.

**NOTE:** Piston rings are not assembled.

**NOTE:** Shape of the piston pin is .

(See Fig. 38.)

6) Assemble the cylinder

**NOTE:** Insert the piston into the cylinder (piston ring is not inserted.), and measure the dimensions of the head of piston and upper surface of the cylinder.

**NOTE:** The concave dimensions of the piston is  $-0.6 \sim -0.7$  mm from the upper surface of the piston.

**NOTE:** Adjustment of the concave dimensions is to be made by the shim underneath the cylinder, and available thickness of the shim are 0.1 mm and 0.2 mm.



**NOTE:** Fit the piston rings on the piston.

Punched mark "N" are to be faced up. Open end of each ring must avoid the direction toward the thrust side and it is to be set to the different three directions.

**NOTE:** Set the cylinder.

Be sure to fit rubber "O" ring and shim.

Notched portion of the cylinder skirt must be set on the side of the gear case cover. (See Figs. 39-1 and 39-2.)

TOP RING   
SECOND RING   
OIL RING 

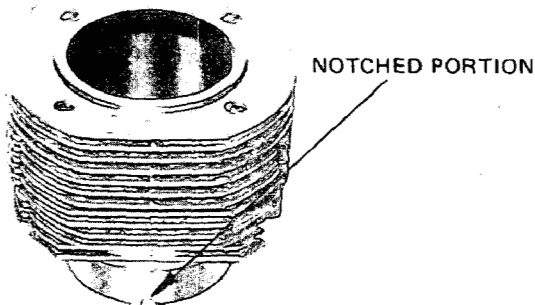

Fig. 39-1

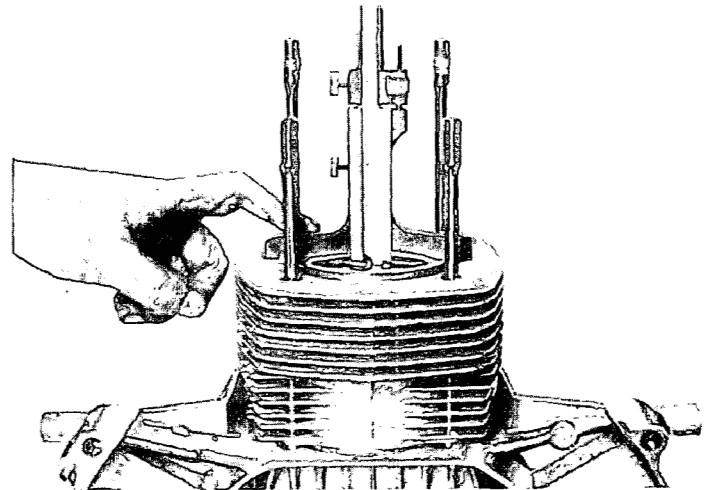

Fig. 39-2

7) Install the flywheel.

(Use 41 mm box wrench.)

**NOTE:** When putting lock washers on, be sure to bend the tabs securely.

[Tightening torque: 2,000 ~ 2,200 kg-cm]

(See Fig. 40.)

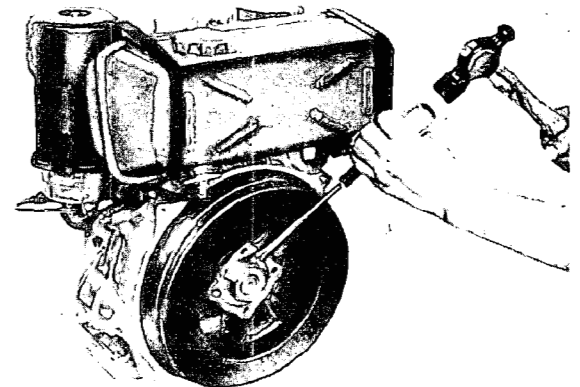

Fig. 40

8) Install the camshaft.

**NOTE:** Apply oil or grease to the inside of oil seal for the gear case cover.

**NOTE:** Set the match mark of the camshaft so as to fit to that of the crank gear. Side clearance is to be adjusted to 0.1 ~ 0.3 mm. Three kinds of shim are available, viz. 0.8 mm, 1.0 mm and 1.2 mm.

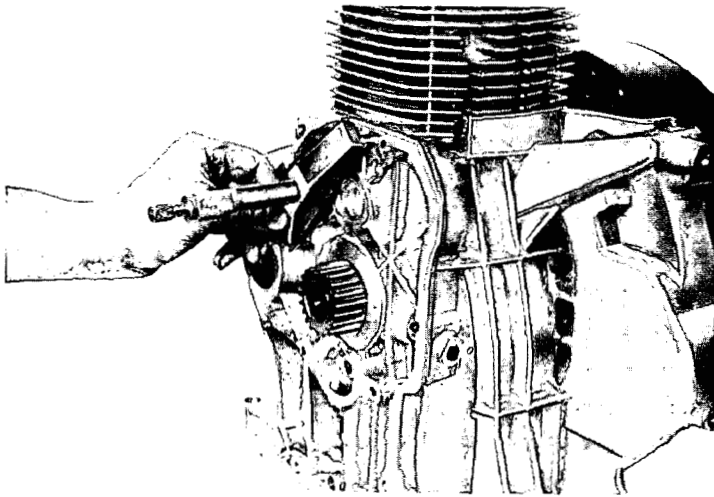

Fig. 41

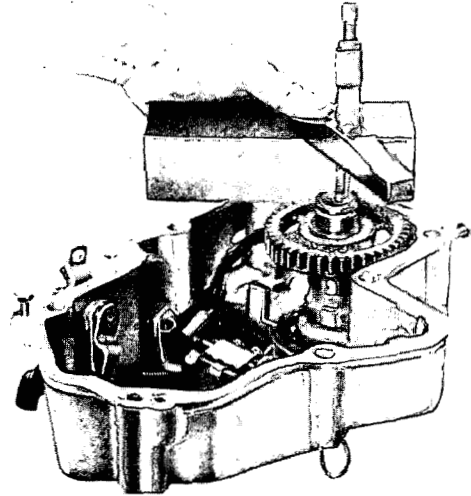

Fig. 42

9) Assemble the oil pump and the governor.

6 x 20 7T bolt . . . . . 2 pcs.

Spring washer . . . . . 2 pcs.

**NOTE:** The hole in the oil pump cover is to face downward.

**NOTE:** Check if the governor sleeve moves smoothly.

Outer surface of the trochoid pump must face the case side. (See Fig. 43.)

[Tightening torque: 80 ~ 100 kg-cm]

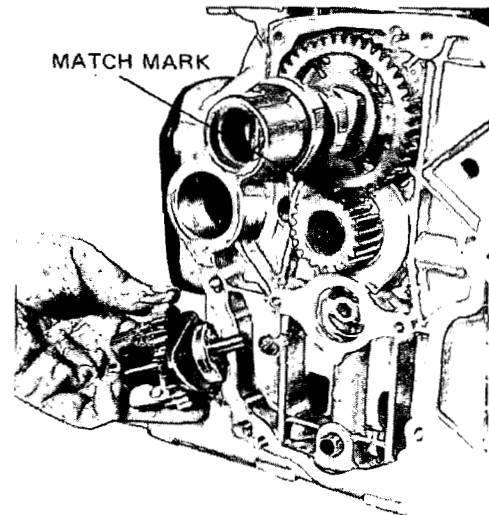

Fig. 43

10) Assemble the gear case cover.

8 x 5 7T bolt . . . . . 4 pcs.

Spring washer . . . . . 4 pcs.

**NOTE:** When the pin is replaced, apply "Three Bond" at the both ends of the pin for cranking. This pin locates at the top of the camshaft.

8 x 65 7T bolt . . . . . 3 pcs.

Spring washer . . . . . 3 pcs.

**NOTE:** Check if the governor link operates.

[Tightening torque: 200 ~ 230 kg-cm]

11) Assemble the injection pump.

8 mm nut . . . . . 3 pcs.

Spring washer . . . . . 3 pcs.

**NOTE:** Measure the distance between the face of the cam base and the surface to which the injection pump is to be fitted. And adjust it may become  $76 \pm 0.05$  mm, using the shims. Two kinds of the shim are available, viz. 0.1 mm, and 0.3 mm.

**CAUTION:** Remove the oil filler cap and check if the control rack comes off from the governor lever.  
(See Figs. 44 and 45.)

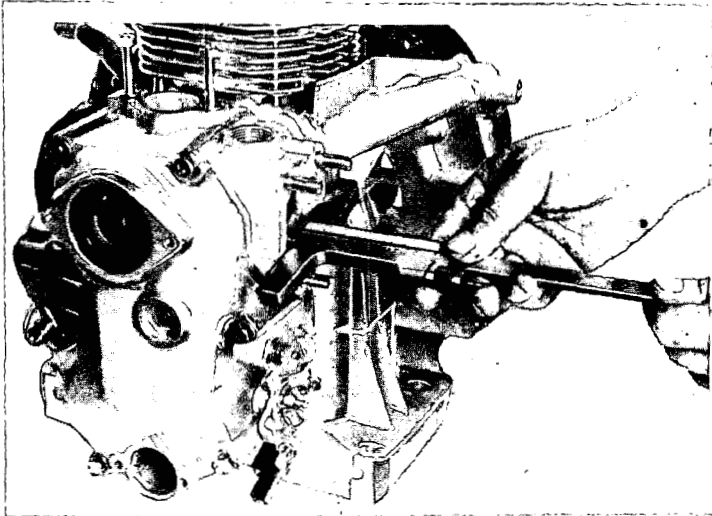

Fig. 44

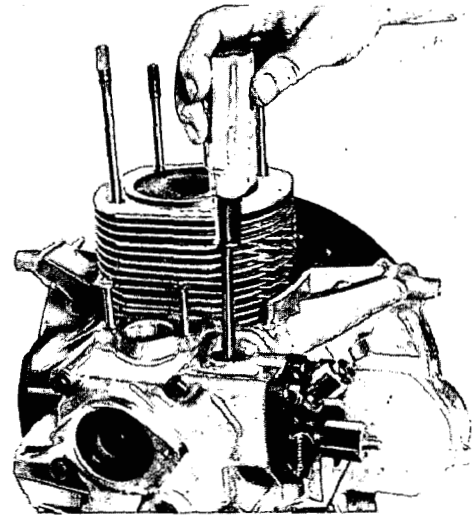

Fig. 45

12) Assemble the tappet guide.

**CAUTION:** Be careful not let the tappet fall in the case.

**NOTE:** The roll pin of the tappet guide is to be set at the right side as viewed from the gear case side.

(See Fig. 46.)

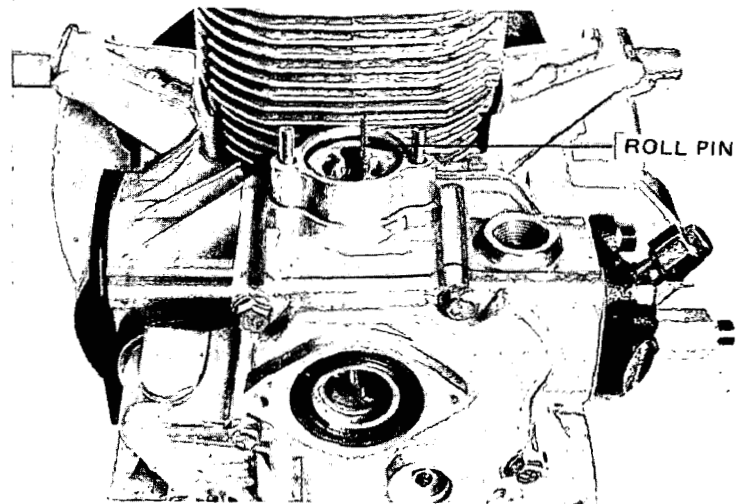

Fig. 46

13) Temporarily assemble the push rod sleeve.

6 mm nut . . . . . 2 pcs.

Spring washer . . . . . 2 pcs.

**NOTE:** 2 pcs. of the plate (push rod sleeve) are to be assembled temporarily.

14) Assemble the cylinderhead.

10 mm flange nut . . . . . 4 pcs.

Washer . . . . . 4 pcs.

**NOTE:** Install the intake and exhaust valves. On the intake side there is a stem seal.

**NOTE:** Insert the push rod. (Exhaust is on the side of the gear case.) Pay attention to the valve facing, upward or downward, and direction of intake and exhaust.

**NOTE:** Install the rocker arm to the cylinder.

It is advisable to insert the rocker shaft before clamping the head.

(See Fig. 47.)

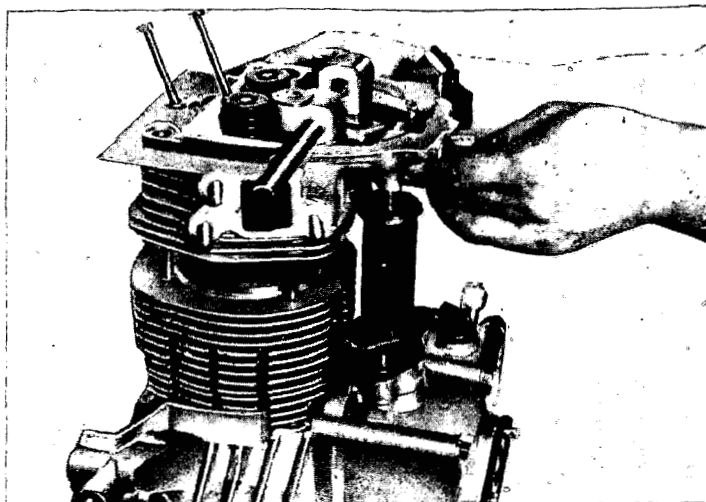

Fig. 47

**NOTE:** Clamp the head to the cylinder.

Apply "Three Bond #1215" to two pieces of the stud bolt (on the side of the rocker shaft) and upper and reverse surfaces of the washer, and then tighten the nuts.

[Tightening torque: 350 kg-cm]

Tightening of the nuts is to be done in three rounds, i. e.:

1st round . . . . . 100 kg-cm

2nd round . . . . . 200 kg-cm

3rd round . . . . . 330 ~ 350 kg-cm

**NOTE:** Fasten tightly the plate (push rod sleeve).

6 mm nut . . . . . 4 pcs.

(See Fig. 48.)

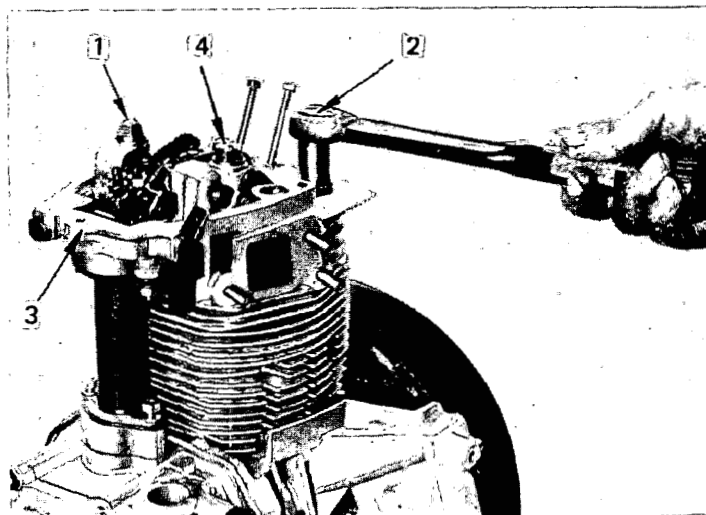

Fig. 48

15) Adjust the valve clearance.

**NOTE:** Turn the flywheel by hand to the compression at TDC (top dead center). At TDC the camshaft cranking pin stands vertically.

**NOTE:** Adjust the valve clearance to anywhere between 0.07 ~ 0.10 mm (both intake and exhaust), when the engine is cold.

(See Fig. 49.)

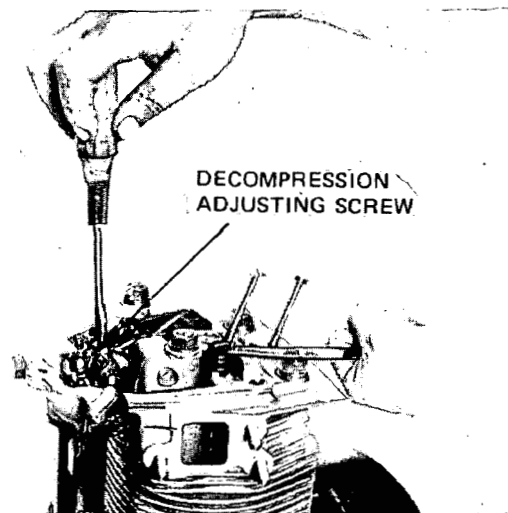

Fig. 49

## INTAKE, EXHAUST VALVE TIMING

When valve clearance is at 0.4 mm and the engine is heated,

intake valve opens at  $16^\circ$  before TDC,

intake valve closes at  $54^\circ$  after BDC,

exhaust valve opens at  $54^\circ$  before BDC, and

exhaust valve closes at  $14^\circ$  after TDC.

(See Fig. 50.)

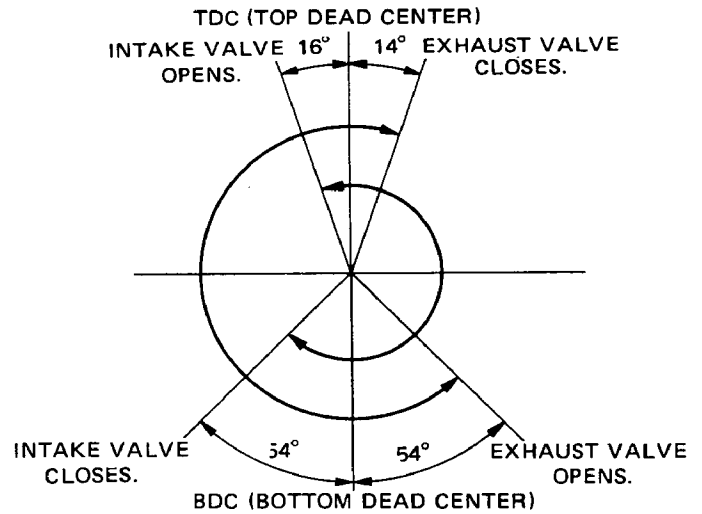

Fig. 50

- 16) Adjust the decompression clearance.

**NOTE:** The decompression device locates in the rocker arm on the intake valve side.

**NOTE:** Set the decompression lever at the position of decompression. (Push the lever to the horizontal position.)

**NOTE:** Clearance is about 0.5 mm. Turn the adjust screw until it touches the decompression shaft, and then make another half turn. Threading of this screw is 1.0 mm.

Turn the flywheel by hand and check a contact between the valve and the piston.

- 17) Assemble the rocker cover.

6 x 35 7T bolt . . . . . 3 pcs.

Spring washer . . . . . 3 pcs.

**NOTE:** Check if there is an "O" ring for breather hole on the surface of the head (intake breather's side).

**NOTE:** Check if the gasket for the rocker cover is put correctly in the groove.

- 18) Install the nozzle holder.

6 mm nut . . . . . 2 pcs.

Spring washer . . . . . 2 pcs.

**NOTE:** Pay attention to the gasket at the top. It is advisable to utilize the driver for easy installation.

[Tightening torque: 90 ~ 100 kg-cm]

- 19) Install the blower housing.

Upper part: 8 x 55 7T bolt . . . 2 pcs.

Spring washer . . . . 2 pcs.

Lower part: 8 x 40 7T bolt . . . 2 pcs.

Spring washer . . . . 2 pcs.

- 20) Install the driving shaft.

10 x 30 bolt . . . . . 4 pcs.

- 21) Assemble the flywheel cover.

8 x 16 bolt . . . . . 4 pcs.

- 22) Assemble the cylinder baffle.

6 x 8 flange bolt . . . . . 2 pcs.

5 x 75 round head cross recess

bolt and nut 5 mm . . . . . 1 pce. each

(See Fig. 51.)

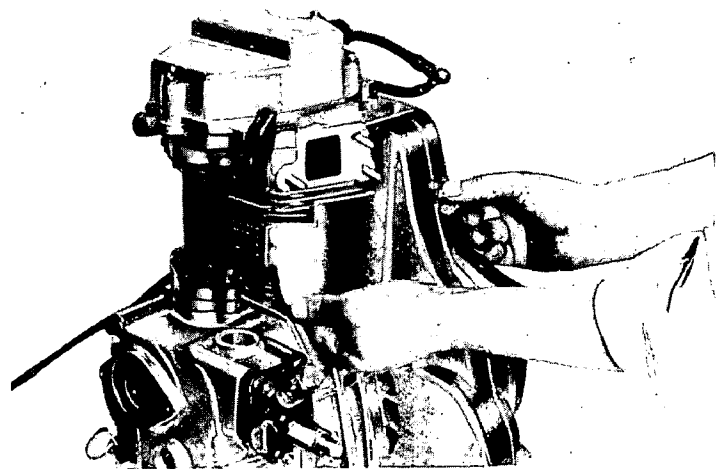

Fig. 51

- 23) Install the tank brackets, left and right.  
 8 x 16 7T bolt . . . . . 2 pcs.  
 Spring washer . . . . . 2 pcs.  
 8 mm nut bolt . . . . . 2 pcs. each

- 24) Connect the fuel pipe and fuel return pipe securely.  
 8 x 18 banjo bolt . . . . . 2 pcs.  
 Aluminum packing . . . . . 2 pcs.

**NOTE:** Connect the pipe to the nozzle first, and then connect the fuel pipe to the tank.

- 25) Install the air cleaner.  
 8 mm nut . . . . . 2 pcs.  
 Spring washer . . . . . 2 pcs.

**NOTE:** Pay attention to the gasket.

- 26) Install the muffler and the muffler cover.  
 Muffler: 8 mm brass nut . . . . . 2 pcs.  
           Spring washer . . . . . 2 pcs.  
 Muffler cover: 6 x 8 flang bolt . . 4 pcs.

**NOTE:** Pay attention to the gasket.

- 27) Connect the high pressure pipe. (See Fig. 52.)  
 It is advisable to remove the cap of the air cleaner and then connect.

- 28) Mount the fuel tank.  
 6 x 45 round head cross recess  
 screw . . . . . 2 pcs.  
 When installing the fuel filter once removed from the tank, fasten the filter by hand and then make 1/4 turn with a spanner.

- 29) Install the oil filter  
 6 x 12 bolt . . . . . 2 pcs.  
 Spring washer . . . . . 2 pcs.  
 The oil filter serves as the oil drain plug too.  
 Be sure to install "O" ring.

- 30) Install the handle guide.  
 6 x 12 bolt . . . . . 2 pcs.  
 Spring washer . . . . . 2 pcs.

- 31) Supply engine oil.  
 Upper level . . . . . 1.0 ℓ max.  
 Lower level . . . . . 0.6 ℓ min.  
 Also pour oil into the air cleaner, watching oil level.

- 32) Supply diesel light oil.  
 Fuel tank capacity . . . . . 4.5 ℓ

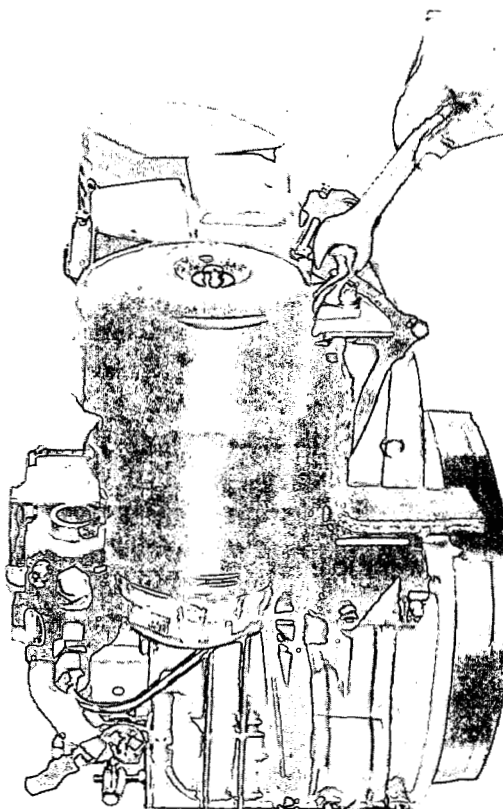

*Fig. 52*

## 6. FUEL

### 6-1 QUALITY of FUEL

Because of the high speed diesel engine, be sure to use the good quality diesel light oil. If improper fuel is used, the injection pump, nozzle, and piston develop troubles. (See Fig. 53.)

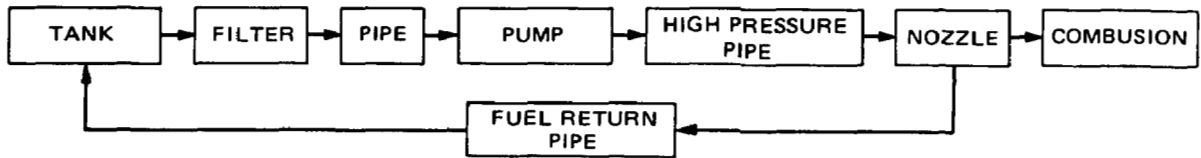
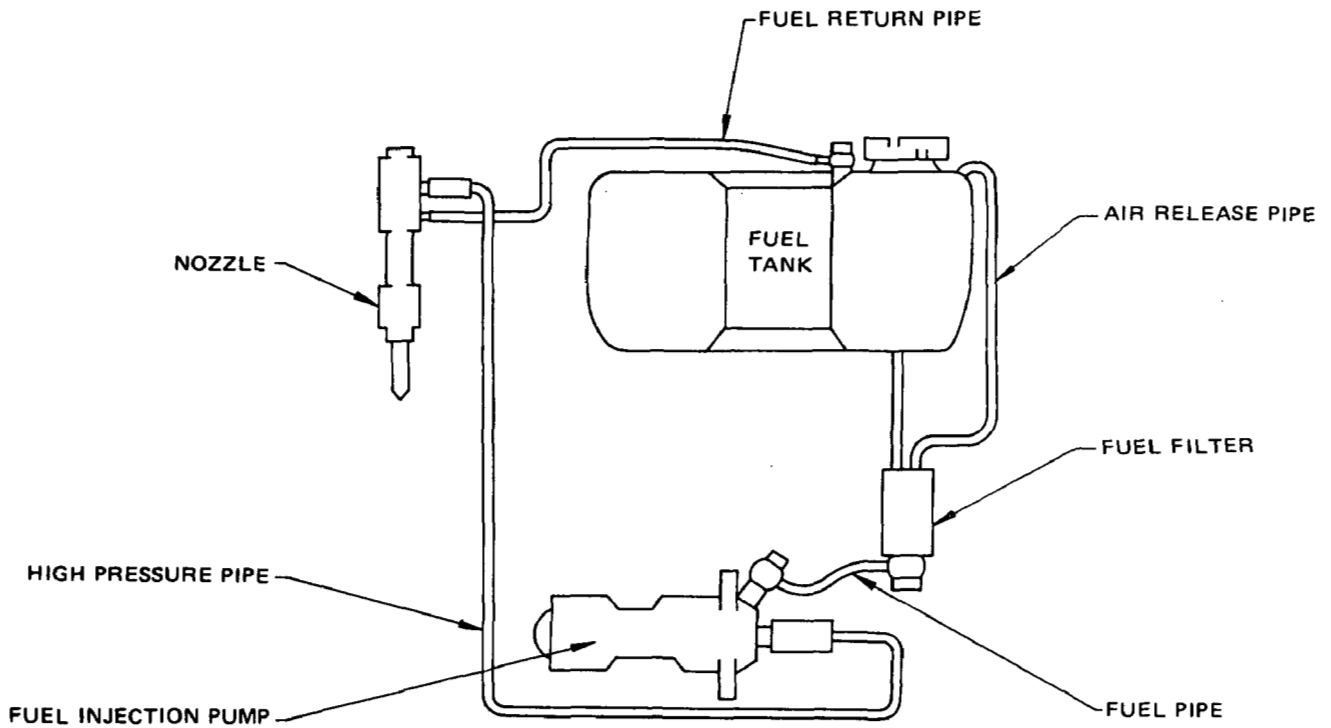

Fig. 53

## 7. GENERAL DESCRIPTION of AUXILIARY GADGETS and PARTS

### 7-1 FUEL INJECTION PUMP MECHANISM

It is not too much to say that the fuel injection pump is the heart of the diesel engine, and it must be precise enough to satisfy the following functions.

#### 1. Function

- 1) Injecting fuel, starting with high pressure and ending with low pressure.
- 2) Injecting the predetermined amount of fuel accurately at each stroke.
- 3) Injecting fuel at specified time within a specified time interval.
- 4) Quantity being injected is closely varied by the governor to suit to varying load.
- 5) This engine has no automatic advancing device, but in starting (max. delivery), the injection timing is to be delayed.

#### 2. Theory of the injection pump mechanism

The plunger of the injection pump is pushed up by the cam of the camshaft, and it is pushed down by the plunger spring. By this up and down motion in a stroke, suction and forced supply of fuel are conducted. (See Fig. 54.)

##### 1) Suction of fuel

Through the filter in the fuel tank, fuel is supplied and is in full around the intake port of the plunger barrel. When the top of the cam lobe passed the tappet and cam function ended, plunger spring pushes down the plunger.

When the plunger is pushed down passing the fuel intake, fuel is sucked into the barrel, and suction is continued until arrival of the plunger at the bottom of its stroke. This is on the stage of "suction."

##### 2) Forced supply of fuel

The camshaft rotates and pushes up the plunger. Forced supply of the fuel is started only when the upper part of the plunger closed the fuel intake in the course of being pushed up by the cam rotation. The fuel in the barrel is pressurized by a very strong force ( $100 \text{ kg/cm}^2$  and up), and as a result, the force of the fuel pushes up the delivery valve and the damping valve, and then it injects the fuel into combustion chamber. This is on the stage of "pressurized supply."

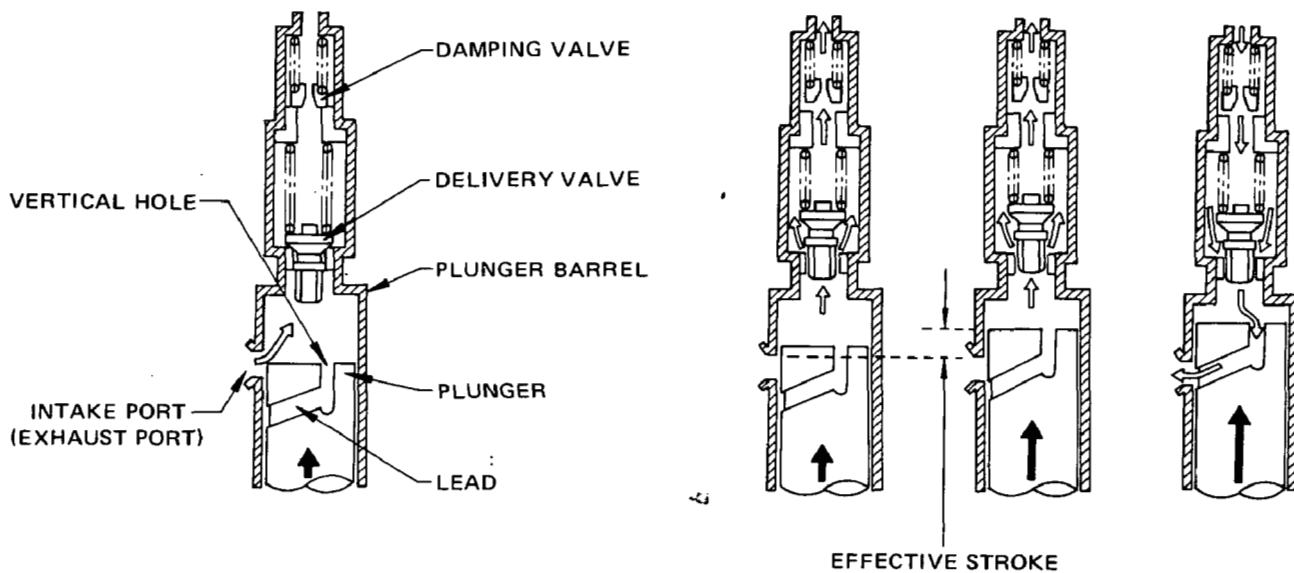

Fig. 54



### 3. Variation in quantity of fuel to be injected

The quantity of fuel injected varies according to the condition of the engine, i. e. high speed or low speed operation and loaded or unloaded operation. (See Figs. 55 and 56.)

The plunger lead is engraved on the surface of plunger in an inclined curve. By rotating the plunger, the distance between the upper part of the plunger and the suction port is varied. (Variation in effective stroke)

Rotation of the plunger is made by the control rack. When this control rack is shifted to left and/or right, the geared pinion rotates, which is connected to the plunger by means of the control sleeve. In other words, the plunger turns as much amount as the rack rotates. Accordingly, the effective stroke varies coincident with the position where the rack is set.

#### 1) Relation between the plunger and the barrel

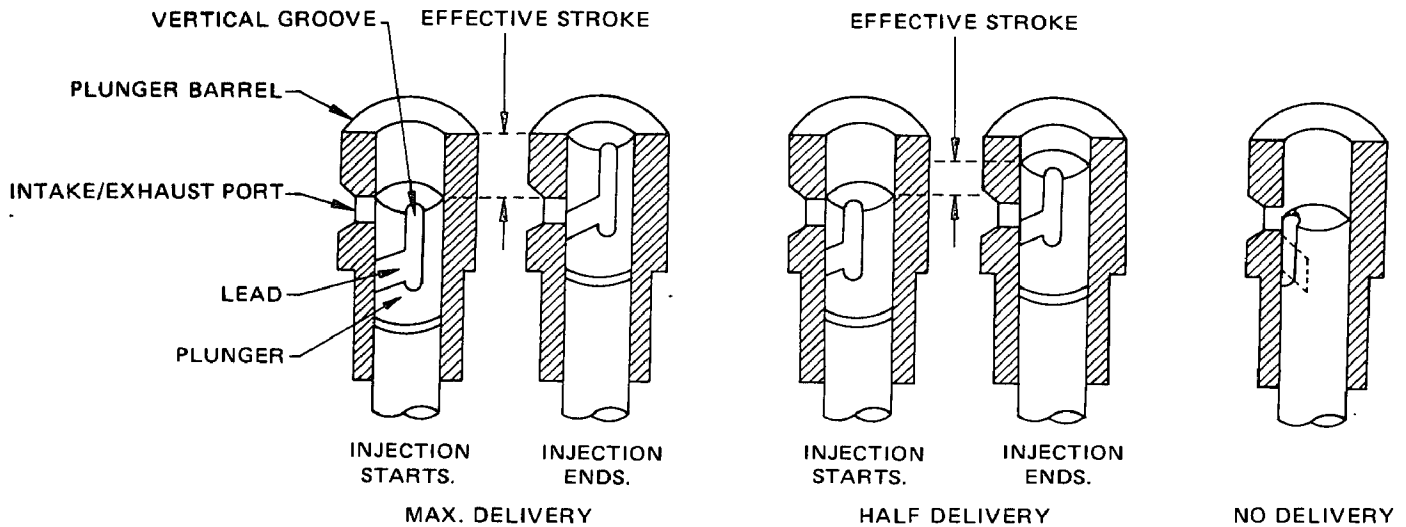

Fig. 55

#### 2) Relation between the plunger and the rack

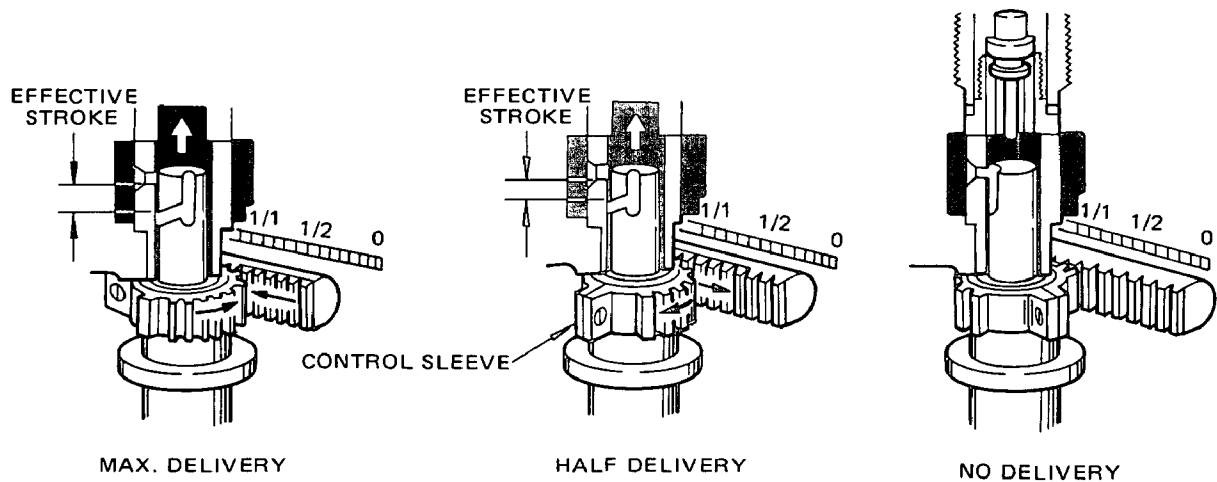
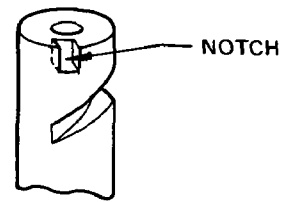

Fig. 56

#### 4. Injection timing and effective starting

When the plunger closes suction port of the barrel, forced delivery of fuel starts. But fuel is not injected from the nozzle at once because of contraction of fuel, etc.

Injection timing of this engine is fixed constant ( $23^\circ$  before TDC) irrespective of engine rpm. On the other hand, in starting, a proper delay from the timing for high speed running and increased fuel injection is indispensable for effective starting. For this purpose a notch is made at the plunger head, which reserves to delay the injection timing by nearly  $8^\circ$  to facilitate starting. (See Fig. 57.)



INSTALLED ONLY TO DY30

Fig. 57

#### 5. Function of the delivery valve

By the plunger stroke, fuel pressure is raised. And when it becomes higher than the pressure remained in the high pressure pipe, the delivery valve spring is pushed down and the valve opens. As the result, the fuel in the high pressure pipe is delivered forcibly. When the plunger lead meets suction port of the plunger barrel, delivery of fuel ends, and the delivery valve is closed by the spring tension of the valve. At this time, delivery valve prevents reverse flow of the fuel. Also suction back motion around the upper part of the plunger sucks back the fuel in the equal amount of the stroke [A] and decreases remaining pressure in the high pressure pipe. The nozzle jets the fuel clearly off and prevents after dripping. (See Fig. 58.)

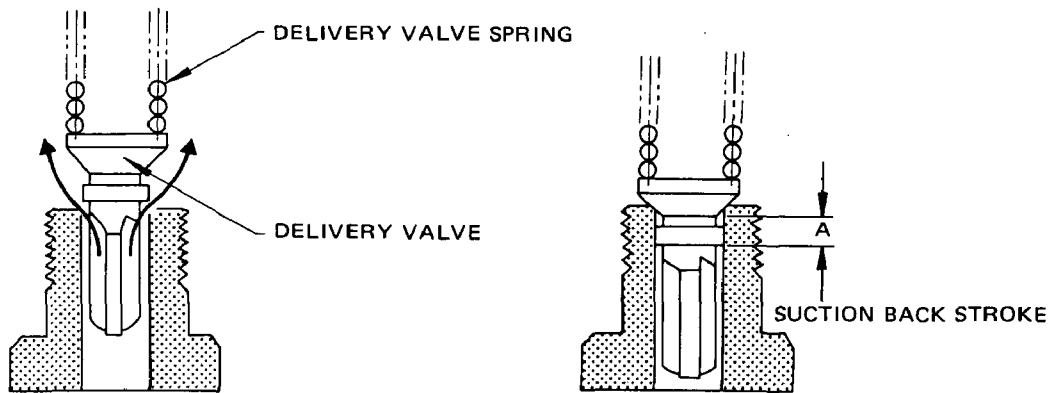

Fig. 58

#### 6. Function of the damping valve

The damping valve is assembled in the end of injection pump and it reaches the seat before arrival of delivery valve at the seat. The small orifice in the valve is the passage of fuel to the chamber in the delivery valve holder. Accordingly, descending velocity of the delivery valve is decreased, which prevents the negative pressure being produced suddenly. As a result, proper injection is conducted and the engine noise is decreased. (See Fig. 59.)

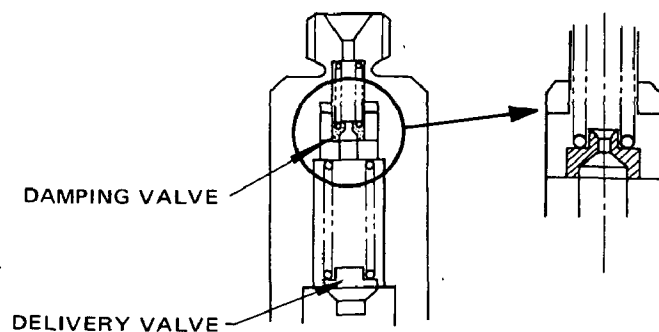

Fig. 59

● FUEL INJECTION PUMP

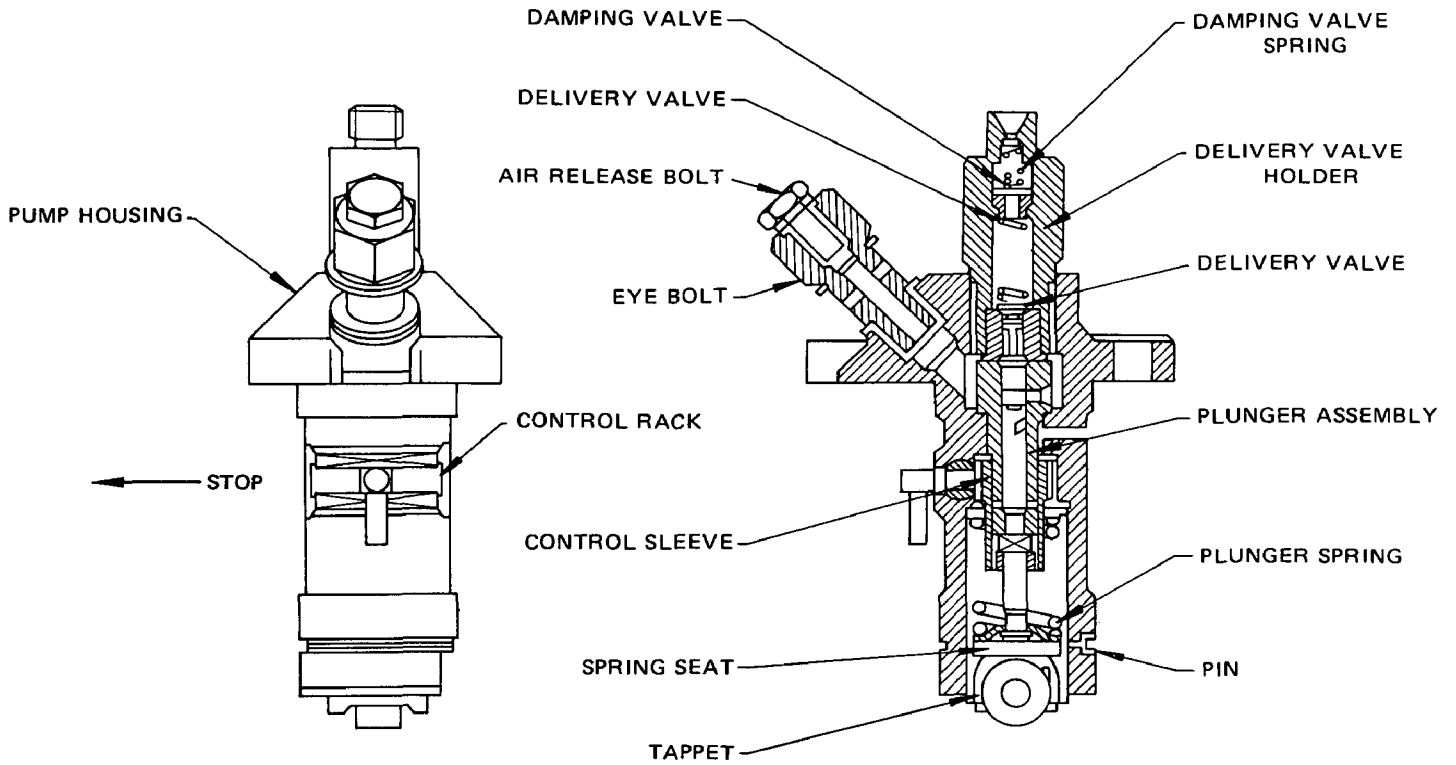

Fig. 60

● SPECIFICATIONS of FUEL INJECTION PUMP for THIS DIESEL ENGINE

Model	PFR1KD55/2NP1
Maker	Diesel Kiki K.K.
Plunger diameter	5.5 mm
Lift	7 mm
Lead	Right twist lead
Plunger spring arbitrary	2.46 kg/cm
Delivery valve opening pressure	27.5 kg/cm <sup>2</sup>
Delivery valve spring constant	0.51 kg/mm
Pump rack friction load	0.062 kg
Rack stroke	16 mm

## 7-2 FUEL INJECTION NOZZLE HOLDER

### 1. Specifications

Part Name	NOZZLE HOLDER
Part No.	105 11840 00
Identification mark	C
No. of nozzle hole (Diameter)	4 (0.22 mm)
Valve opening pressure	195 kg/cm <sup>2</sup>
Spring constant	13.2 kg/cm <sup>2</sup>

### 2. Features

Both the injection nozzle and the injection pump are very important parts for producing fuel fog for combustion. There are two types of injection nozzle, one is hole type and the other is pintle type. The injection nozzle for DY30 and DY35 Diesel engine is developed as a result of joint research and development project by Diesel Kiki, K. K. and our company, and it is direct combustion system, having the special hole type nozzle.

For producing better combustion gas, it utilizes swirl and squish flows and for producing the most proper fuel fog, injection pressure is raised up to 195 kg/cm<sup>2</sup>.

### 3. Structure of the ignition nozzle holder

This consists of the nozzle holder and nozzle. The nozzle holder fixes the nozzle to the cylinderhead and at the same time it plays the role of fuel passage to the nozzle. (The valve opening pressure of nozzle is adjustable. However, the nozzle for DY30 and DY35 engines includes spacer in it and it is unadjustable.)

The nozzle consists of the nozzle body and needle valve; and when the pressure reaches the limit to open the valve, nozzle for this diesel engine includes spacer in it and it is unadjustable.)

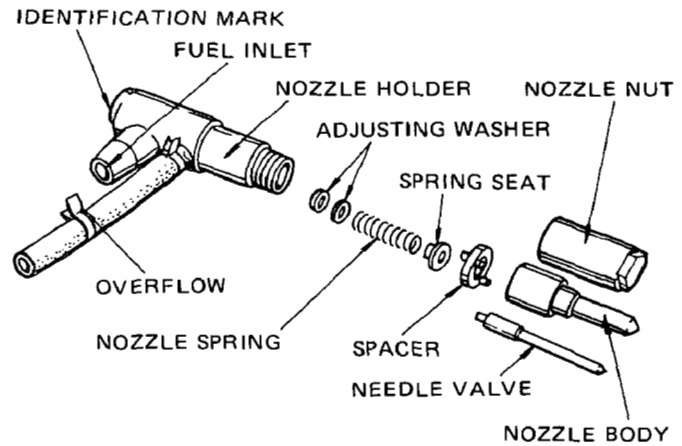

Fig. 61

### 4. Function of nozzle

Through the injection pump, fuel is delivered forcibly into the nozzle body and it raise up the needle valve and is atomized in the combustion chamber through the holes of the nozzle body. In case of the hole type nozzle, the size of the opening of the holes does not alter. (See Fig. 62.)

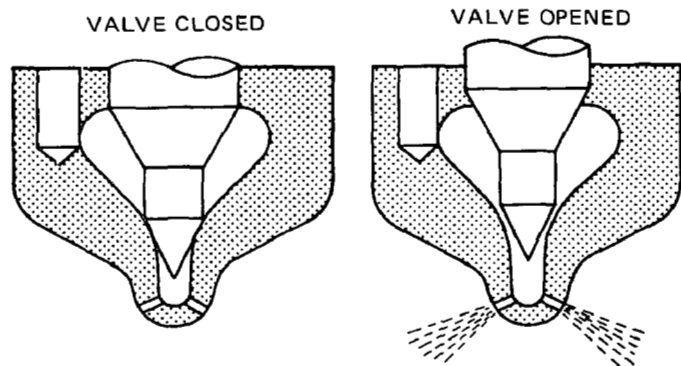

Fig. 62

## 5. Fuel passage

From the plunger pump fuel is sent through the high pressure pipe 1 to the fuel passage 2. Then, at the nozzle body 3, it is pressurized up till  $195 \text{ kg/cm}^2$  and it lifts up the needle valve 4 for 0.18 mm, and is sprayed into the combustion chamber via the jet hole 5.

An excess fuel which lubricated the inside of the nozzle and nozzle holder returns to the fuel tank via the needle valve → nozzle spring 6 → overflow pipe 7 → fuel tank.

(See Fig. 63.)

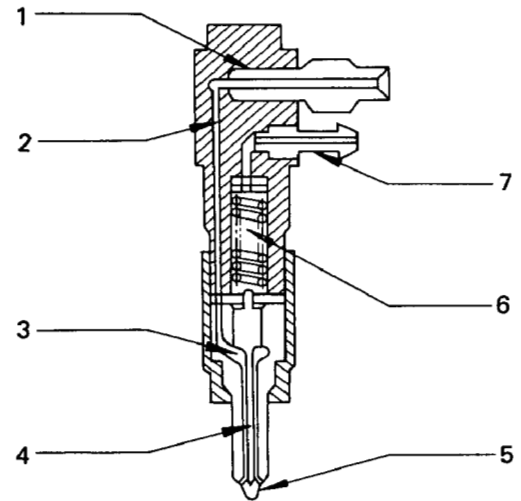

Fig. 63

## 6. Inspection and maintenance

Fuel spraying condition of the nozzle and the state of pressure at starting injection are quite influential to the engine malfunction, insufficient output, increase of noise and exhaust smoke. Use of improper fuel and contaminated fuel is one of the main courses of the nozzle trouble. Therefore, exert good care for management of fuel. As the nozzle is one of the very precisely processed parts, utmost care and attention must be paid when inspecting and checking.

### 1) Inspection

After cleaning nozzle holder outside, inspect in the below sequence.

#### a) Visual inspection

- \*Whether or not injection hole is damaged, or clogged with carbon.
- \*Whether or not injection hole is clogged with dust and carbon.

#### b) Inspection by nozzle tester

- \*Fit the nozzle holder to the nozzle tester.

**CAUTION:** When removing the nozzle from the engine or fitting it to the tester, be sure to keep the nozzle free of dust.

- \*Move the lever of the nozzle up and down for 2 ~ 3 times and suck the air inside the nozzle.

**CAUTION:** Never bring your face near the pressurized fog from the nozzle. Also keep away your hands from the fog.

- \*Gently push down the lever of the nozzle tester and read the pressure gauge just before the fuel being injected. If the figure coincides with the standard value, the nozzle is in a good condition.

- \*Push further and check whether or not the fuel fog is injected straight.

**CAUTION:** Good injection is straight forward. Just after injection, check "after dripping."

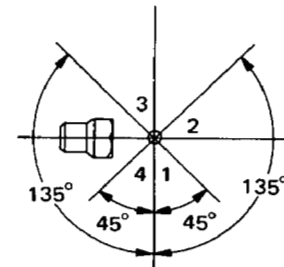

Fig. 64

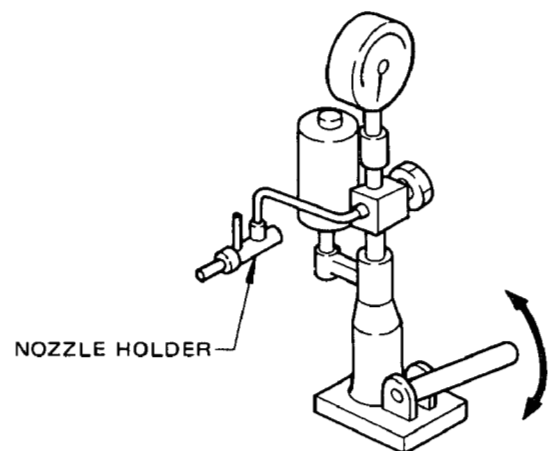
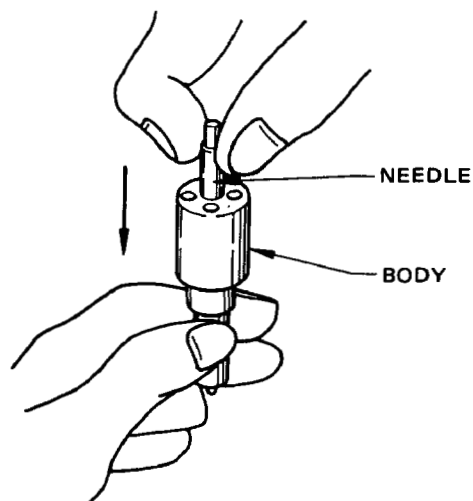

Fig. 65

## 2) Maintenance

If the test results are found not good (poor injection and “after dripping”), carefully check and repair in the following manner:

- a) Disassemble the nozzle holder and nozzle, and wash in clean light oil. When washing, use a wooden chip (for instance, wooden chopstick is servicable.) for peeling off the carbon adhered to the nozzle.
- b) After washing, pull out the needle halfway from the body of nozzle with your fingers and then let it go. And check if the needle sinks by its own dead weight.
- c) If it does not sink, replace it in the form of a set.
- d) Frinction surfaces of both the needle and nozzle body are ultra precise finish. So, be sure to keep the parts free of dust.
- e) If “after dripping” is found, it is poor contact between the needle valve and the seat. In such a case, it is advisable to replace it in the form of a set, needle valve and nozzle body. However, it is possible to coat chrome oxide on the tapered surface of the needle and get a good contact. Wash very carefully after correction.
- f) Adjustment of the valve opening pressure of the nozzle spring in the nozzle holder is unnecessary because it was already adjusted by the adjusting washer.
- g) The spacer is an important part to set positions of the nozzle holder and the nozzle body. Pay attention to the position of the pin.
- h) When fitting the nozzle body to the nozzle holder, conform to the specified tightening toruqe, viz.  
**[Tightening torque: 400 ~ 500 kg-cm]**
- i) Recheck with the nozzle tester, if necessary.



*Fig. 66*

### 7-3 GOVERNOR MECHANISM and OPERATION

#### 1. Mechanism

The governor is centrifugal flyweight type, which means a flyweight is fitted to the governor gear. The governor sleeve is assembled so that it may slide toward the direction of the axis of the pump shaft, and it is in contact with the flyweight. The governor sleeve gets in touch with the governor yoke, and through the governor lever it makes the control rack of injection pump operate. This mechanism enables to maintain constant operation irrespective of load variation.

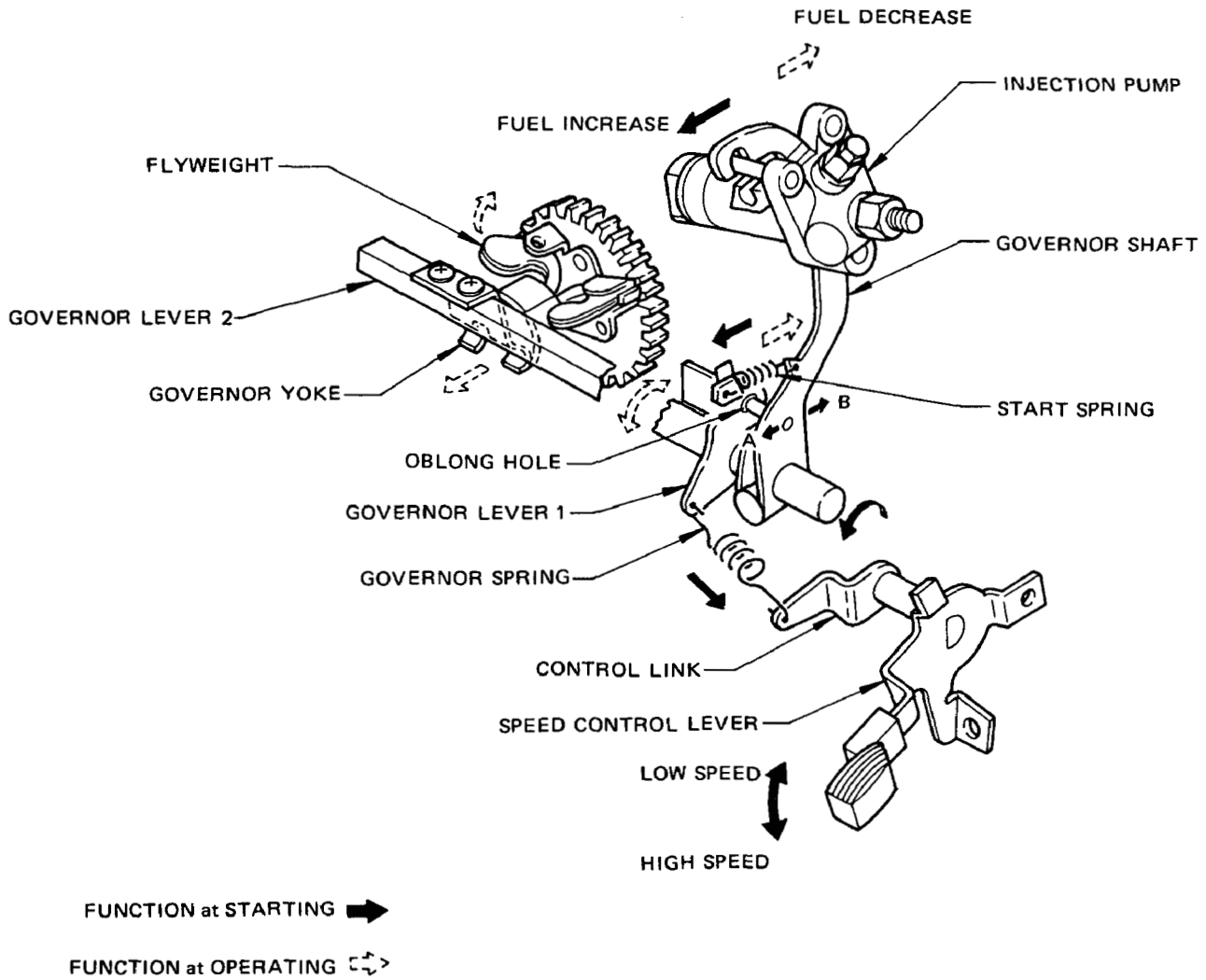

Fig. 67

## **2. Operation**

### **1) Starting**

When the speed control lever is set on the side of high speed, the governor spring is pulled via the control link. The governor levers **1** and **2** are pulled by the tension of the governor spring. The control rack of injection pump is pushed toward "fuel increase." The governor lever **1** has an oblong hole, and the governor lever **2** moves to the extent of this oblong hole by means of the start spring tension. The control rack of injection pump is pushed toward the maximum of "fuel increase." This movement within the extent of oblong hole is called "revolution playing angle," for which we will explain later.

### **2) After starting and during operation**

When engine starts up, centrifugal force acts on the flyweight and it pushes the governor sleeve. The governor yoke, governor shaft, and governor lever **2** are assembled in one piece, and accordingly the motion of the governor sleeve pushes the control rack of the injection pump toward "fuel decrease." The governor lever again moves to the extent of the oblong hole. Thereafter, the governor lever **1** and the governor lever **2** move simultaneously and are balanced at the specified revolution. Suppose that a load is put suddenly on, the fuel supply is as it is at that instance, accordingly the fuel supply is insufficient against the load. As a result, engine revolution decreases, which means that the centrifugal force on the flyweight decreases. Then the governor lever **2** moves to the position where it balances the tension of the governor spring. The control rack of injection pump is pushed toward "fuel increase" and engine revolution revives.

### **3) Stopping**

The governor plays a role exactly reverse to that of starting. When the speed control lever is set at the position of "Stop," it pushes the control rack of injection pump toward "No Injection" and the engine stops.

## **3. "Revolution Playing Angle"**

This mechanism is to supply more fuel than the maximum supply for normal high speed operation. This mechanism is developed for the purpose of improving starting ability.

Required amount of fuel supply is set by the governor lever **1**. The governor lever **1** has an oblong hole, to which pins of the governor lever **2** is fitted. As the start spring is pulling the governor lever **2**, it moves toward the arrow mark **A**. Then the control rack of the injection pump is pushed to "Maximum supply." The angle the governor lever **2** moves within the extent of oblong hole is called "Revolution Playing Angle."

At the time of starting, the governor does not function as yet and the governor lever **2** functions. However, during operation, the governor functions and accordingly the governor lever **2** moves toward the arrow mark **B** within the extent of oblong hole. The governor levers **1** and **2** incorporate each other and pushes the control rack of the injection pump.



#### 7-4 LUBRICATION SYSTEM and OIL PUMP

Lubrication is forced lubrication and wholly filtered system by trochoid type oil pump. The oil pump, and the governor are assembled in one piece, which is fitted to the crankcase.

Revolution of the crankshaft is reduced by the reduction gear (1 : 1.4) of the pump; and from the main gallery oil is forcibly lubricated to the crank journal. That oil will further be supplied to the crankpin, large end of the connecting rod, and then splashed to the piston, small end of the connecting rod, cylinder, etc. Also from the main gallery oil is forcibly supplied to the cam shaft bearing and is sent to cam lobe of intake and exhaust valves and lubricate the tappets. In the camshaft oil relief valve is assembled, and it adjusts the oil pressure at  $3 \text{ kg/cm}^2$ . Lubrication in the rocker chamber is conducted by the splash of oil pushed up by blow-by gas, which lubricates rocker arm, etc.

Furthermore, blow-by gas containing oil will pass through the breather, intake port and the cylinder, where it is finally burnt.

#### LUBRICATION CHART

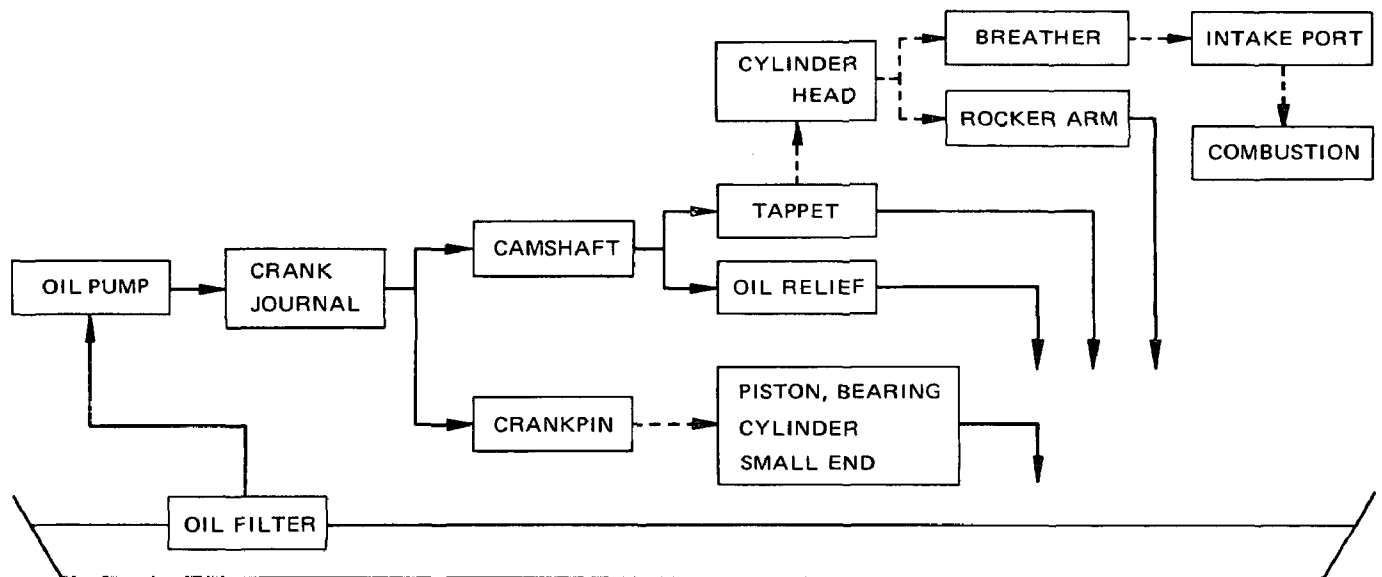

Fig. 68

#### 7-5 OIL FILTER

Oil filter is made of double sheets of wire netting, and it is less flow resistance type, and is called full-flow type. As the element is made of wire, it can be washed and used for many times.

## 7-6 ELECTRIC APPARATUS (Electric Starter)

### 1. Wiring diagram

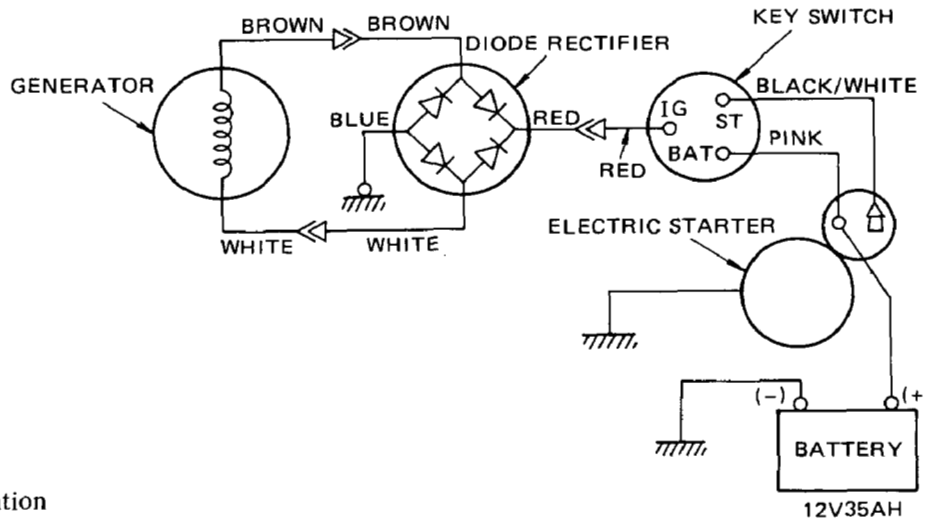

#### 1) Circulation

When starting by the electric starter, (Key is at the position of start.)

Battery (+) → BAT of key → ST of key → Starter → Battery (-) (earth)

Charging, operating (Key is at the position of operation.)

Generator → Rectifier → IG of key → BAT of key → Battery (+)

### 2. Lead wire for electric starter

When mounting the engine, location of the battery may come into question, but set the lead wire following method:

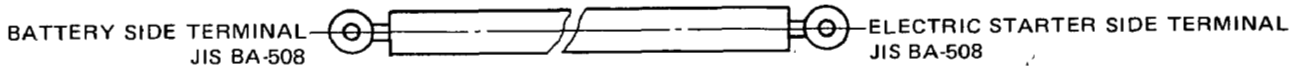

### 3. Earth band Plain woven lead wire sectional area 20 mm<sup>2</sup> and up.

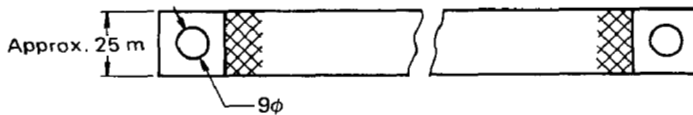

Fasten tightly to the place made of metal and not paint coated. The place must be electrically conducted completely to the crankcase of the engine.

### 4. Other remarks

- 1) All lead wires are classified by coloring, so when connecting, select and connect by color. Meantime, insert the connectors each other up till the roots.
- 2) The wire from (+) terminal of the battery must be connected to (+) terminal of the electric starter, and the wire from the (-) terminal must be connected to the earth of the engine body.
- 3) Select the wire from the below Table A, based on the required length of the wire.
- 4) When the key switch is set apart from the engine body, select the wire from below Table B, based on the required length of the wire between the key switch and the magnetic switch on the side of engine.

Length	Description	Outside dia.
1.5 m or shorter	AV15	7.3 mm
1.5 m ~ 2.5 m	AV20	8.5 mm
2.5 m ~ 3 m	AV30	10.8 mm

Table A

Length	Description	Outside dia.
1.5 m or shorter	AV1.25	1.5 mm
1.5 m ~ 3 m	AV2	1.9 mm
3 m ~ 5 m	AV3	1.4 mm

Table B

## **8. INSTALLATION**

Engine life, ease of maintenance and inspection, frequency of checks and repairs, and operating cost all depend on the way in which the engine is installed. Carefully observe the following instructions for installing the engine.

### **8-1 INSTALLING**

When mounting the engine, carefully examine its position, the method of connecting it to a load (machine), the foundation, and the method of supporting the engine.

### **8-2 VENTILATION**

Fresh air is necessary for cooling the engine and burning the fuel.

In cases where the engine is operated under a hood or in a small room, temperature rise in the engine room can cause vapor lock, oil deterioration, increased oil consumption, loss of power, piston seizure, shorter engine life, etc., making it impossible to operate the engine properly. It is necessary, therefore, to provide a duct or baffle to guide cooling air to the engine to prevent recirculation of the hot air used for engine cooling, and temperature rise of the load (machine).

Take steps as necessary to keep the engine room temperature below 60°C even in the hottest period of the year.

### **8-3 EXHAUST GAS DISCHARGE**

Exhaust gas is noxious. When operating the engine indoors, be sure to discharge the exhaust gas outdoors. If a long exhaust pipe is used in such a case, the internal resistance increases causing loss of engine power. Thus pipe inside diameter must increase in proportion to exhaust pipe length.

Exhaust pipe: Less than 3 m long, pipe inside diameter 30 mm,  
Less than 5 m long, pipe inside diameter 38 mm.

### **8-4 FUEL SYSTEM**

If the fuel tank is removed from the engine when mounting the engine with a machine, set the fuel tank 50 ~ 500 mm above the fuel injection pump. If the tank is set too low, the fuel will not be supplied.

When piping be careful of heat conduction, pipe size, bends, and leaks from the joints and make the fuel pipe as short as possible to prevent air and vapor from being trapped.

### **8-5 POWER TRANSMISSION to DRIVE MACHINES**

#### **1. Belt Drive**

Take the following notes into consideration.

- 1) V-belts are preferable to flat belts.
- 2) The driving shaft of the engine must be parallel to the driven shaft of the load.
- 3) The driving pulley of the engine must be in line with the driven pulley of the load.
- 4) Install the engine pulley as close to the engine as possible.
- 5) If possible, span the belt horizontally.
- 6) Disengage the load when starting the engine.

If no clutch is used, use a belt tension pulley or the like.

#### **2. Flexible Coupling**

When using a flexible coupling, runout and misalignment between the driven shaft and engine shaft must be minimized. Runout and misalignment tolerance are specified by the coupling manufacturer.

## 9. CHECKS and CORRECTIONS

After disassembling and cleaning the engine, check and repair, if necessary, according to the correction table. The correction table applies whenever the engines are repaired. It is important for the servicemen to be familiar with the contents of this table. Correct maintenance is recommended by observing the correction standards specified.

The meanings of the terms used in the correction table are as follows:

1) Correction

Repair, adjustment or replacement of any engine parts.

2) Correction Limit

The limit on wear, damage or functional deterioration of engine parts beyond which normal engine performance cannot be expected without repairing such parts.

3) Use Limit

The limit beyond which parts can no longer be used in respect of performance or strength.

4) Standard Dimensions

The design dimensions of new parts minus tolerance.

5) Correction Tolerance

Tolerance on the dimensions of engine parts refinished or adjusted.

### 10. TABLES of CORRECTION STANDARDS

ITEM			STANDARD DIMENSIONS	CORRECTION		USE LIMIT	REMARKS	CORRECTION METHOD
				TOLERANCE	LIMIT			
Cylinderhead	Flatness			0.03	0.05			
	Valve seat contact width	Intake	1.4		2.2			
		Exhaust						
Valve guide I.D.			7 dia.	+0.015 0	0.15			
Cylinder	Inside dia.	DY30D, B	76 dia.	+0.019 0	0.1	0.25		
		DY35D, B DY41D, B	82 dia.	+0.022 0				
	Roundness after boring				0.01			
	Cylindricity after boring				0.015			
Piston	O.D. at skirt, in thrust direction (Incl. over size)	S. T. D.	DY30D, B	75.96	0 -0.02	-0.1	-0.1	
			DY35D, B DY41D, B	81.94				
		Oversize A	DY30D, B	76.21				
			DY35D, B DY41D, B	82.19				
		Oversize B	DY30D, B	76.46				
			DY35D, B DY41D, B	82.44				
	Width of groove for the rings			Top	+0.060 +0.040	0.13	0.13	
				2nd				
				Oil	+0.025 +0.005	0.1	0.1	
	Piston pin hole			21 dia.	+0.008 +0.001	0.03	0.03	
Clearance between piston and cylinder	DY30D, B			0.040L~0.079L	0.15	0.15	Skirt portion	
	DY35D, B DY41D, B			0.060L~0.102L	0.2	0.2		
Clearance between piston ring and ring groove			Top	0.05L~0.09L	0.15	0.15		
			2nd					
			Oil	0.015L~0.055L	0.1	0.1		
Fit between piston and piston pin				0.005L~0.008L	0.05L	0.05L		
Piston Ring	Piston ring gap		Top	0.3 ~ 0.5				
			2nd					
			Oil	0.25 ~ 0.45				

ITEM		STANDARD DIMENSIONS	CORRECTION		USE LIMIT	REMARKS	CORRECTION METHOD	
			TOLERANCE	LIMIT				
Piston Ring	Piston ring width	Top 2		-0.1	-0.1			
		2nd 1.5						
		Oil 4						
Piston pin O.D.		21 dia.	+0.006 0	-0.02	-0.02			
Connecting Rod	Large end I.D.		43 dia.	+0.016 0				
	Metal thickness of large end		1.5	-0.005 -0.018	1.4	1.4	Metal in center	
	Clearance between large end and crankpin			0.01L~0.068L	0.1	0.1		
	Small end I.D. after the bush is force fitted.		21 dia.	+0.034 +0.013	0.05	0.05		
	Clearance between small end and piston pin			0.007L~0.034L	0.08	0.08		
	Large end side clearance			0.07L ~ 0.33L	0.5	0.5		
	Parallelism between large end and small end bores			0.06	0.1	0.1		
Crankpin O.D.		40 dia.	+0.040 +0.024	0.15	0.5			
Crankshaft	Crankpin O.D.	roundness		0.005				
		cylindricity						
		parallelism						0.008
	Journal diameter		42 dia.	0 -0.016	0.15	0.15		
	Journal roundness			0.005				
	I.D. after main bearing being force fitted			+0.076 +0.020	0.15	0.15		
	Main bearing			0.101L~0.060L				
Clearance between journal and main bearing			0.020L~0.092L					
Camshaft	Cam lobe height	Intake and exhaust cams	36.495	±0.05	-0.2	-0.2		
		Injection pump cam	40		-0.15	-0.15		
	Journal O.D.	Rear	22 dia.	-0.020 -0.041				
Front		35 dia.	-0.012 -0.023					
Valve	Valve stem O.D.	Intake	7 dia.	-0.063 -0.078	-0.15	-0.15	Use searcher and adjust with adjust screw.	
		Exhaust		-0.083 -0.098				

ITEM			STANDARD DIMENSIONS	CORRECTION		USE LIMIT	REMARKS	CORRECTION METHOD
				TOLERANCE	LIMIT			
Valve	Clearance between valve stem dia. and valve guide	Intake		0.063L ~ 0.093L	0.3	0.3		
		Exhaust		0.083L ~ 0.113L				
	Valve clearance both intake and exhaust (cool condition)			0.07 ~ 0.1				
Tappet	Stem O.D.		8 dia.	-0.013 -0.033	-0.07	-0.07		
	Guide I.D.			+0.015 0	+0.08	+0.08		
	Tapet guide clearance				0.013L ~ 0.048L	0.15	0.15	
Rocker Arm	Rocker shaft O.D.		12 dia.	-0.016 -0.034	-0.08	-0.08		
	Rocker arm hole dia.			+0.018 0	+0.07	+0.07		
	Rocker arm shaft clearance				0.016L ~ 0.052L	0.15	0.15	
Valve spring free length			36.5				-1.5	
Injection Pump	From injection pump flunge surface to cam base		76	±0.05			Adjust	
	Static injection timing		23° before TDC			±1°		
Nozzle	Injection starting pressure		195 kg/cm <sup>2</sup>					
	Nozzle dia. x number of nozzle		0.22 dia. x 4 pcs.					

TABLE of TIGHTENING TORQUE

Description	Tightening torque
Gear case cover	200 ~ 230 kg-cm
Blower housing fastening bolt	200 ~ 230 kg-cm
Cylinder head fastening bolt	330 ~ 350 kg-cm
Connecting rod cap fastening bolt	250 ~ 270 kg-cm
Flywheel fastening nut	2,000 ~ 2,200 kg-cm
Rear bearing fastening bolt	200 ~ 230 kg-cm
Oil pump cover fastening bolt	80 ~ 100 kg-cm
Nozzle bracket fastening nut	90 ~ 100 kg-cm

## 11. MAINTENANCE and STORING

The following maintenance jobs apply when the engine is operated correctly under normal conditions. The indicated maintenance intervals are by no means guarantees for maintenance free operations during these intervals.

For example, if the engine is operated in extremely dusty conditions, the air cleaner should be cleaned every day instead of every 50 hours.

### 11-1 DAILY CHECKS and MAINTENANCE

Checks and maintenance	Reasons for requiring them
Remove dust from whatever parts which accumulated dust.	To be contaminated with dust when disassembling each and every part.
Check external fuel leakage. If any, retighten or replace.	Not only wasteful but also dangerous
Check screw tightening. If any loose one is found, re-tighten.	Loose screws and nuts will result in vibration accidents.
Check oil level in crankcase and add up as necessary.	If the engine is operated without sufficient oil, it will fail.

### 11-2 EVERY 25 HOURS CHECKS and MAINTENANCE

Checks and maintenance	Reasons for requiring them
Change crankcase oil.	To remove run-in wear particles

### 11-3 EVERY 50 HOURS (10 DAYS) CHECK and MAINTENANCE

Checks and maintenance	Reasons for requiring them
Change crankcase oil.	Contaminated oil accelerates wear.
Clean oil filter.	If the engine is operated without sufficient oil, it will fail.

### 11-4 EVERY 100 ~ 200 HOURS (MONTHLY) CHECKS and MAINTENANCE

Checks and maintenance	Reasons for requiring them
Clean fuel filter and fuel tank.	If the fuel is contaminated, engine will be out of order, and injection pump as well as nozzle are seized.
Clean air filter, and replenish engine oil.	Clogged air filter and shortage of oil will cause engine trouble and make engine life shorter.
Check and adjust valve clearance.	The engine output drops.
Check and clean nozzle.	Engine will be out of order.



**11-5 EVERY 500 ~ 600 HOURS (SEMIANNUAL) CHECKS and MAINTENANCE**

Checks and maintenance	Reasons for requiring them
Remove cylinder head and remove carbon deposit.	The engine will be out of order.
Replace fuel filter.	The engine will be out of order.
Check valve seats both intake and exhaust and grind, if necessary.	The engine will be out of order.

**11-6 EVERY 1000 HOURS (YEARLY) CHECKS and MAINTENANCE**

Checks and maintenance	Reasons for requiring them
Change piston rings.	The engine output drops and become out of order.
Replace fuel pipe once a year.	To prevent from danger caused by the fuel leakage.

**11-7 EVERY 1500 HOURS (OVERHAULS)**

Checks and maintenance	Reasons for requiring them
Perform overhauls, clean, correct or replace parts.	The engine output drops and become out of order.

**11-8 PREPARATION for LONG ABEYANCE**

- 1) Perform the above 11-1 and 11-2 maintenance job.
- 2) Drain fuel from the fuel tank.
- 3) To prevent rust in the cylinder bore, apply oil through the breather hole on the surface of rocker cover and made cranking for 2 ~ 3 times and then fit the rocker cover. Don't apply too much oil as the excess oil will be collected in the combustion chamber of the piston.
- 4) Turn cranking handle and leave it where the restance is the heaviest.
- 5) Clean the engine outside with oiled cloth. Put a vinyl or other cover over the engine and store the engine in dry place.

## 12. 1/2 REDUCER

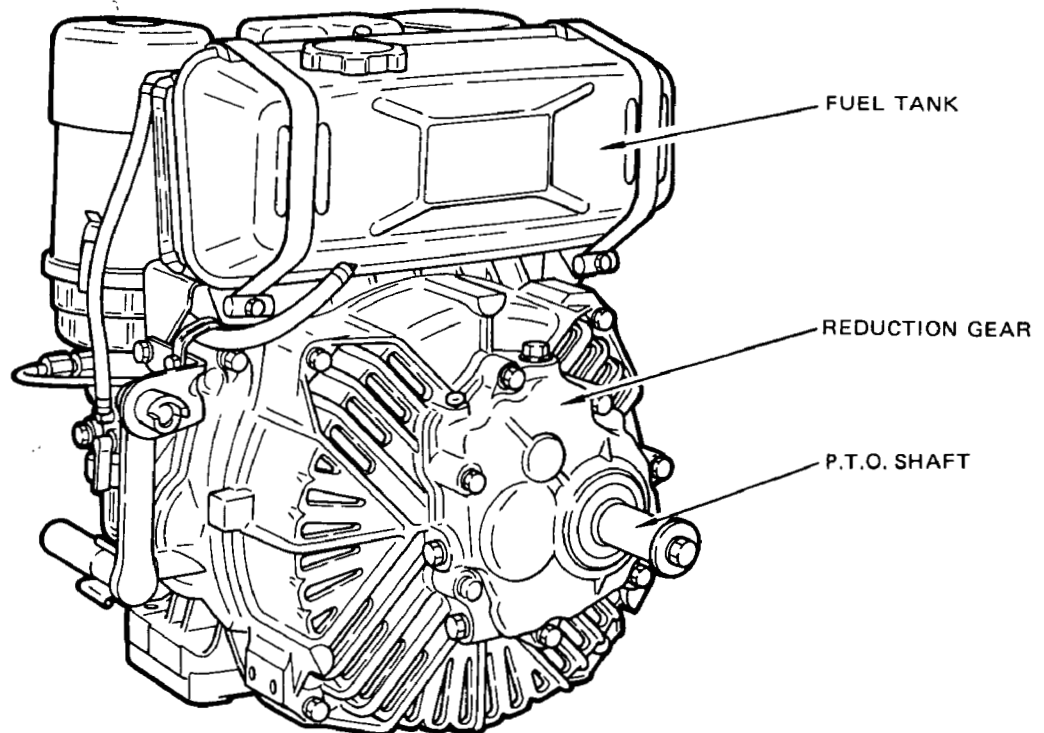
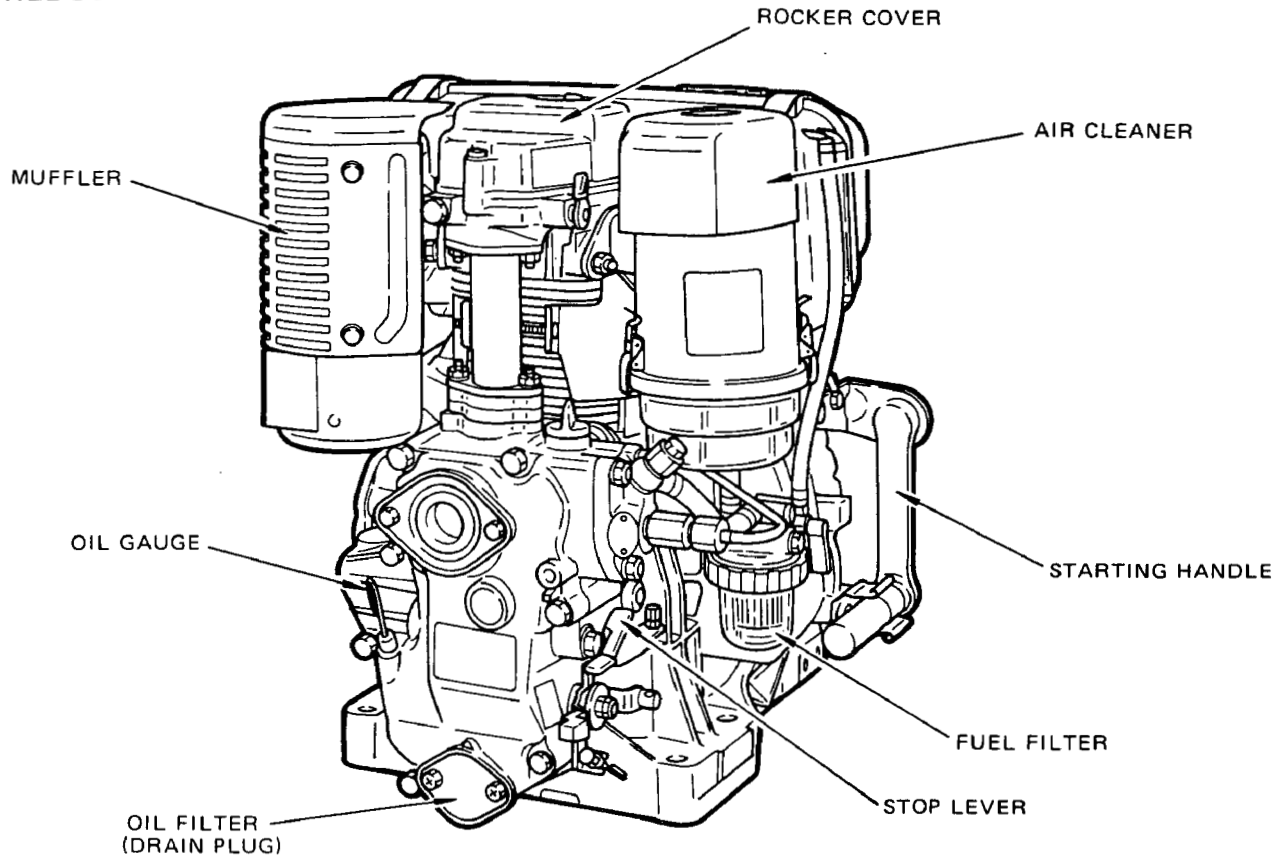

12-1 CONFIGURATION of 1/2 REDUCER

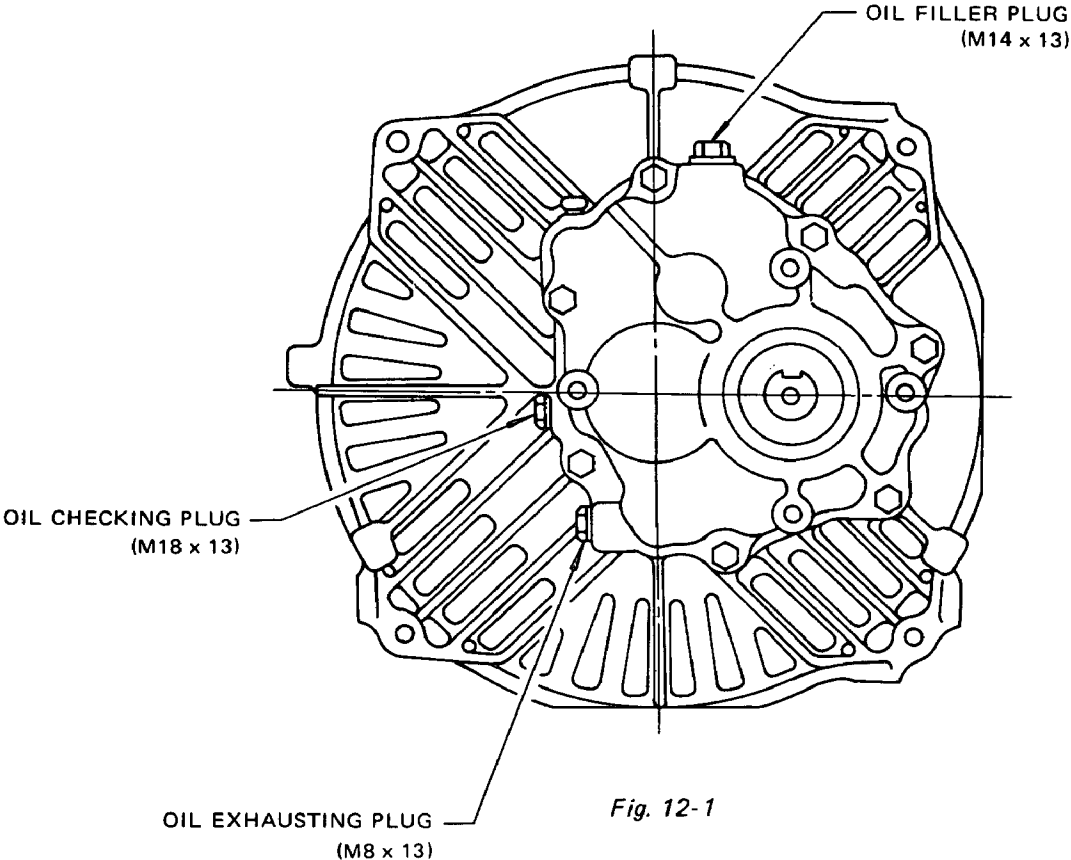

12-2 STRUCTURE of 1/2 REDUCER

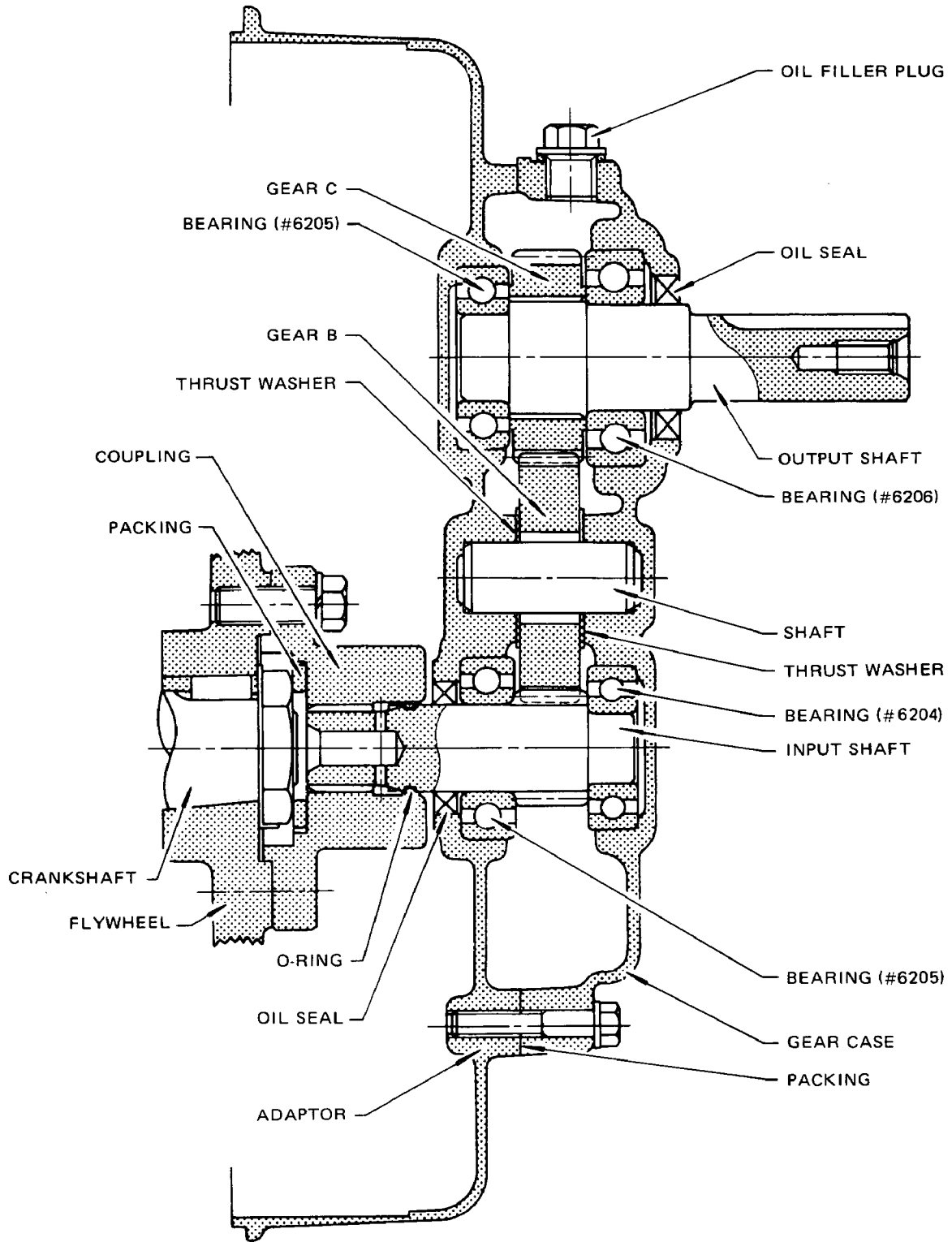

Fig. 12-2

#### 12-2-1 INPUT SHAFT

The input shaft is a wholly carburized product in which chrome-molybdenum steel is used, and the gear A and spline are built in it.

#### 12-2-2 OUTPUT SHAFT

The output shaft is made of carbon steel, and the gear C is fitted in spline engagement.

#### 12-2-3 SHAFT B

The shaft B is made of chrome-molybdenum steel, and wholly carburized.

#### 12-2-4 GEAR C and GEAR B

The gear C and the gear B are wholly carburized products, in which chrome-molybdenum steel is used, and are helical gears with module of 2.

#### 12-2-5 ADAPTOR and GEAR CASE

The adaptor and the gear case are components of a body of the 1/2 reducer, and are made of aluminum alloyed diecast.

#### 12-2-6 COUPLING

The coupling is a component to deliver output from the engine to the 1/2 reducer, and is fitted to the input shaft in spline engagement. The coupling is a wholly carburized product in which molybdenum steel is used.

**NOTE:** Grease is stored in the spline section, and the section is sealed with a packing and an O-ring.

## 12-3 DISASSEMBLY and REASSEMBLY of 1/2 REDUCER

### 12-3-1 DISASSEMBLY SEQUENCE

- Length of the bolt indicates the length from the bold head bottom surface to the threaded end.
- \* SW = Spring washer

Se- quence	Procedures	Main Item to be disassembled	Remarks	Bolts, etc. Used
1	Drain the gear oil.	The oil drain plug is located under the gear case cover.	Replace the gasket with a new one.	8mm hexagonal bolt Opposite side: 13 mm
2	Remove the clamping bolt from the adaptor.	8 mm bolt - - 4 pcs.		8 mm x 65 bolt - - 4 pcs.
3	Remove the 1/2 reducer assembly from the engine.			
4	Remove the clamping bolts from the coupling.	10 mm bolt - - 4 pcs.	Be careful not to lose the packing.	10 mm x 30 9T bolt - - 4 pcs.
5	Remove the clamping bolts of the gear case.	7 bolts on the gear case surface.	Be carefull not to lose the SWs.	8 x 40 7T bolt - - 6 pcs. 8 x 50 7T bolt - - 1 pce. with SWs
6	Remove the O-ring of the input shaft.			
7	Wind vinyl tape around the input/output shafts.		Cover whole surface of the shafts to protect the oil seal.	
8	Separate the gear from the adaptor.		Hold the output shaft and strike the adaptor with a wood hammer or a plastic hammer, and then separate the gear case from the adaptor. Don't insert a driver between the mating faces. If inserted, they may be damaged.	
9	Pull out the gear assembly from the case.			
10	Disassemble the input shaft assembly.	Separate the gear from the bearings.	Pull out the bearings by using a gear puller or a press.	
11	Disassemble the P.T.O. shaft assembly.	Separate the gear and the bearings from the P.T.O. shaft.	Pull out the bearings by using a gear puller or a press.	

## 12-3-2 REASSEMBLING SEQUENCE

### 1. Precautions in Reassembling

- Every and each part should be thoroughly cleaned. Especially, pay utmost care and attention to cleanliness of the bearing.
- Carefully check the lip portion of every oil seal. If damaged one is found, replace it with a new one.
- Replace all the gaskets with new ones.
- Replace the bolts, if necessary, with new ones.
- As for the places where tightening torque is specified, apply the specified torque.
- Apply oil to the revolutionary parts and friction surfaces, when reassembling.
- Check and adjust the clearances of various portions and then reassemble them.
- When some main portions are assembled in the course of reassembling, turn or move the gadgets by hand, paying attention to the frictional noise and resistance.

### 2. Reassembling

- Pressure-fit the bearings into the input shaft so that the bearing (#6205) is set in the spline side and the bearing (#6204) in the edge face side. Then, insert the shim between the bearing (#6205) and the gear so that the clearance between the two bearings after they have been pressure-fitted is from 49 mm to 48.9 mm. Two types of shim; 0.3 mm thick and 0.1 mm thick are available. (See Fig. 12-3.)

When installing the spline and the O-rings in the case, wind vinyl tape around their grooves to protect the oil seals. (See Fig. 12-4.)

#### INPUT SHAFT SHIM ADJUSTING POSITION

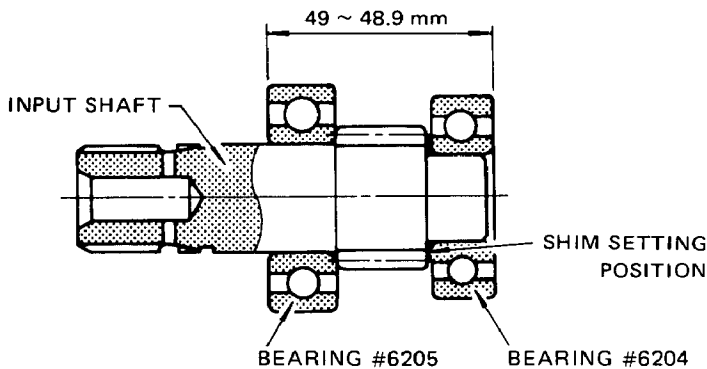

Fig. 12-3

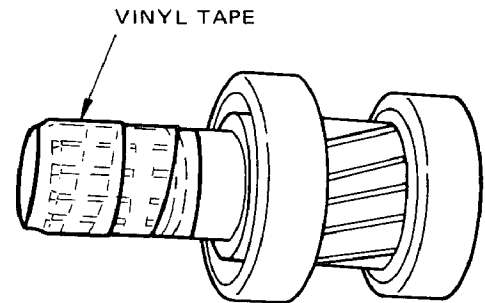

Fig. 12-4

#### OUTPUT SHAFT SHIM ADJUSTING POSITION

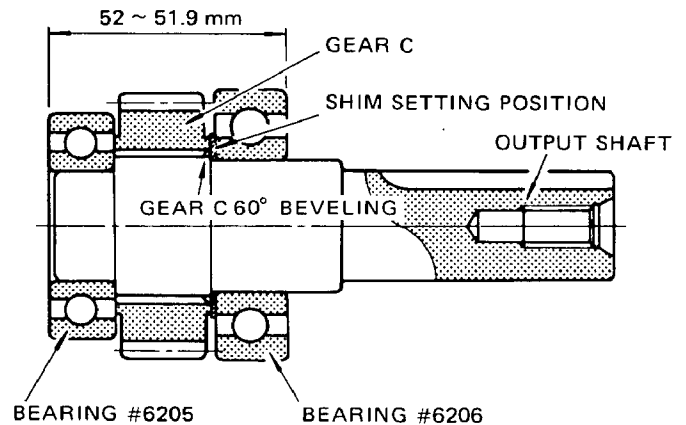

Fig. 12-5

- Pressure-fit the bearings and install the gear C into the output shaft so that the bearing (#6206) is set in the output side, the bearing (#6205) in the edge face side, and the 60 beveling of the gear C bore spline is faced to the bearing (#6206).

Then, insert the shim between the bearing (#6205) and the gear so that the clearances between bearings after they have been pressure-fitted is from 52 mm to 51.9 mm. Two types of shim; 0.3 mm thick and 0.1 mm thick are available. (See Fig. 12-5.)

- c) Pressure-fit the oil seals into the adaptor and the gear case.
- d) Set the shaft B with the thrust washer in the adaptor. (See Fig. 12-6.)
- e) Set the gear A and the gear B in the adaptor, under the condition that their teeth are engaged in each other. (See Fig. 12-7.)
- f) Set the thrust washer onto the edge face of the gear B.
- g) Set the output shaft assembly in the adaptor. (See Fig. 12-8.)
- h) Put the packing on the mating face of the case. (It is not necessary to supply sealing compound to the mating face.)
- i) Cover the gear case. (Don't give physical impacts with such tools as a hammer to compulsorily set it.) (See Fig. 12-9.)
- j) Clamp the case with six M8-40 7T bolts and an M8- 50 7T bolt. Never forget to set thrust washers for the bolts. Tightening torque: 250 kg.-cm  $\pm$ 50 kg-cm.
- k) Remove the vinyl tape around the input shaft, and then set the O-ring.

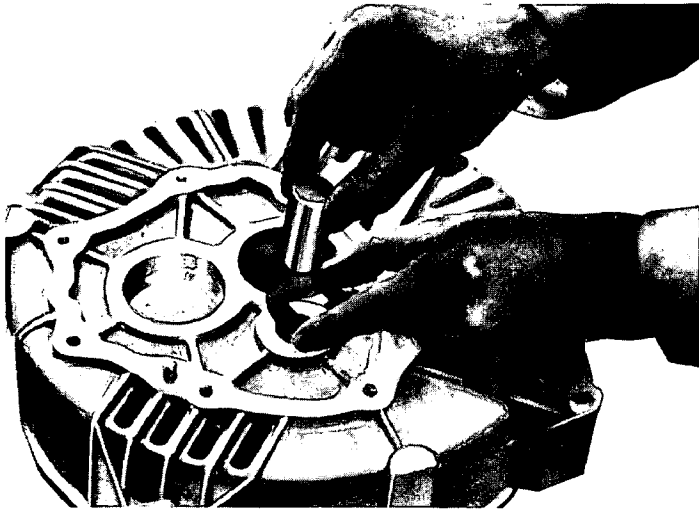

Fig. 12-6

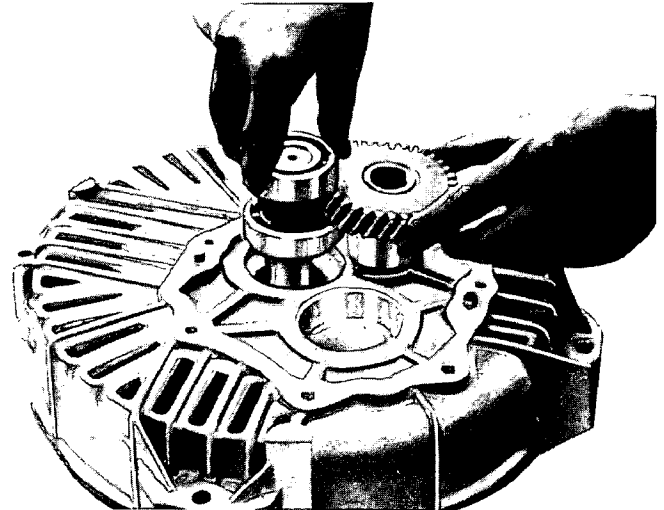

Fig. 12-7

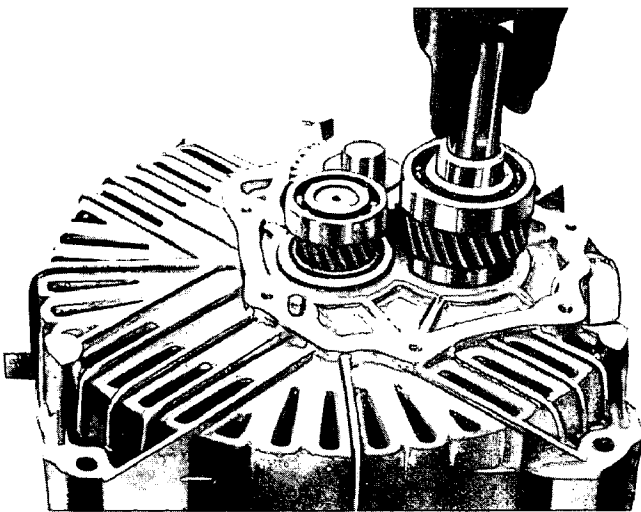

Fig. 12-8



Fig. 12-9



3. Mounting to Engine

- a) Supply grease into the grease filler hole (the section shown with inclined lines in the figure) of the input shaft.
- b) Set the packing in the coupling, and then clamp it to the engine's flywheel with four 10 mm x 30 9T bolts.  
Tightening torque: 550 – 700 kg-cm
- c) Apply grease to the coupling and spline gear teeth of the input shaft.
- d) Set the 1/2 reducer in the engine under the condition that the spline teeth are engaged, and clamp it with four 8 mm x 65 7T bolts. Tightening torque: 200 – 230 kg-cm.”

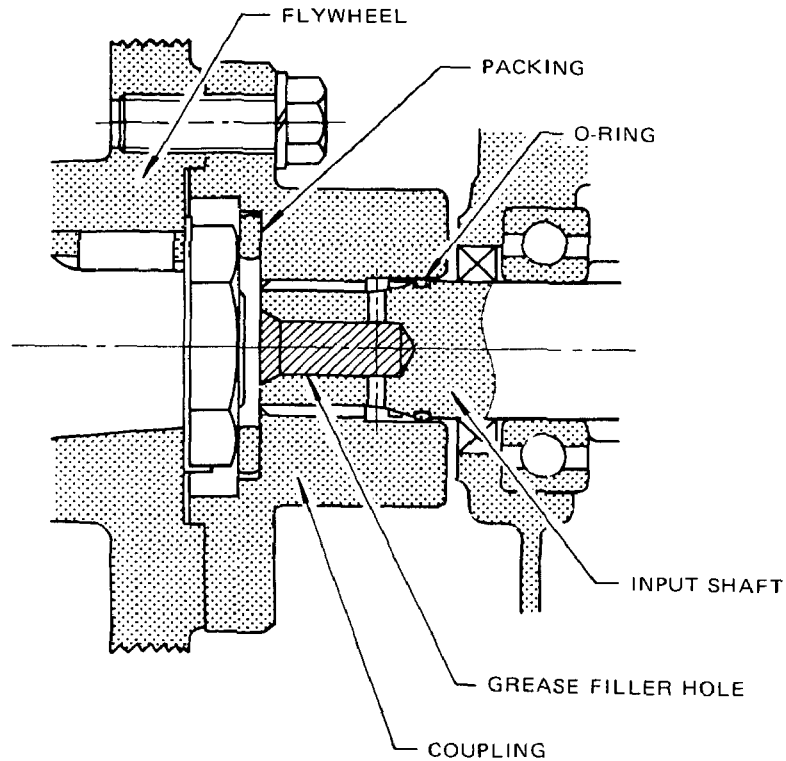

Fig. 12-10



**Robin** Engine

---



**Robin America, Inc.**

940 Lively Blvd., Wood Dale, IL 60191 • Tel: (708) 350-8200 • Fax: (708) 350-8212