

Robin Industrial Engines®

SERVICE MANUAL

Model

EH18V OHV

396S122



ROBIN AMERICA, INC.
ROBIN TO WISCONSIN ROBIN
ENGINE MODEL CROSS REFERENCE LIST

ROBIN

WISCONSIN ROBIN

SIDE VALVE

EY08	W1-080
EY15	W1-145
EY15V	W1-145V
EY20	W1-185
EY20V	W1-185V
EY23	W1-230
EY28	W1-280
EY35	W1-340
EY40	W1-390
EY45V	W1-450V
EY21	EY21W
EY44	EY44W
EY18-3	EY18-3W
EY25	EY25W
EY27	EY27W

OVERHEAD VALVE

EH11	WO1-115
EH12	WO1-120
EH15	WO1-150
EH17	WO1-170
EH21	WO1-210
EH25	WO1-250
EH30	WO1-300
EH30V	WO1-300V
EH34	WO1-340
EH34V	WO1-340V
EH43V	WO1-430V

TWO CYCLE

EC13V	WT1-125V
-------	----------

DIESEL

DY23	WRD1-230
DY27	WRD1-270
DY30	WRD1-300
DY35	WRD1-350
DY41	WRD1-410

CONTENTS

<i>Section</i>	<i>Title</i>	<i>Page</i>
1.	SPECIFICATIONS	1
2.	PERFORMANCE	2
2-1	Maximum Output	2
2-2	Maximum Torque	2
2-3	Performance Curves	2
3.	FEATURES	3
4.	GENERAL DESCRIPTION OF ENGINE COMPONENTS	3
4-1	Cylinder and Crankcase	3
4-2	Main Bearing Cover	3
4-3	Crankshaft	4
4-4	Connecting Rod and Piston	4
4-5	Camshaft	4
4-6	Valve Arrangement	5
4-7	Cylinder Head	5
4-8	Governor System	5
4-9	Cooling System	6
4-10	Lubrication	6
4-11	Ignition System	7
4-12	Carburetor	7
4-13	Air Cleaner	7
4-14	Decompression System	8
4-15	Sectional View of Engine	9
5.	DISASSEMBLY AND REASSEMBLY	11
5-1	Preparations and Suggestions	11
5-2	Special Tools	11
5-3	Disassembly Procedures	12
5-4	Reassembly Procedures	27
5-5	Break-in Operation	40
6.	MAGNETO	41
6-1	Flywheel Magneto	41
6-2	Basic Theory	41
6-3	Wiring Diagram	42
7.	AUTOMATIC DECOMPRESSION SYSTEM	43
8.	CARBURETOR	44
8-1	Operation and Construction	44
8-2	Disassembly and Reassembly	45
9.	STARTING SYSTEM	47
9-1	Recoil Starter	47

<i>Section</i>	<i>Title</i>	<i>Page</i>
10.	TROUBLESHOOTING	51
10-1	Starting Difficulties	51
10-2	Engine Misfires	52
10-3	Engine Stops	52
10-4	Engine Overheats	52
10-5	Engine Knocks	53
10-6	Engine Backfires Through Carburetor	53
11.	INSTALLATION	54
11-1	Installing	54
11-2	Ventilation	54
11-3	Exhaust Gas Discharge	54
12.	SERVICE DATA	55
12-1	Clearance Data and Limits	55
12-2	Torque Specifications	61
12-3	Oil Grade Chart	61
13.	MAINTENANCE AND STORAGE	62
13-1	Daily Maintenance (Every 8 Hours)	62
13-2	Initial 20 Hours Maintenance	62
13-3	Every 50 Hours (10 Days) Maintenance	62
13-4	Every 100-200 Hours (Monthly) Maintenance	63
13-5	Every 500-600 Hours Maintenance	63
13-6	Every 1000 Hours (Yearly) Maintenance	63
13-7	Engine Storage	63

1. SPECIFICATIONS

Model	EH18V
Type	Air-Cooled, 4-Cycle, Vertical Shaft, Overhead Valve, Gasoline Engine
Bore × Stroke	67 × 52 mm (2.64 × 2.05 in.)
Piston Displacement	183 cc (11.16 cu.in.)
Maximum Horsepower	4.4 / 3600 KW / rpm (6 / 3600 HP / rpm)
Maximum Torque	1.29 / 2700 kg•m / rpm (9.3 / 2700 ft. lbs / rpm)
Rotation	Counterclockwise As Viewd From PTO Shaft Side
Cooling	Forced Air Cooling
Lubrication	Oil Pump Type
Lubricant	Automobile Oil SAE #20, #30 or 10W-30
Carburetor	Horizontal Draft Type
Fuel	Automobile Gasoline
Fuel Feed	Gravity Type
Governor System	Centrifugal Flyweight Type
Ignition System	Flywheel Magneto (Solid State)
Spark Plug	CHAMPION L86C
Starting System	Recoil Starter
Dry Weight	17 kg (37.5 lbs.)
Dimensions Without P.T.O Shaft L × W × H	409 × 372 × 311 mm (16.10 × 14.65 × 12.24 in.)

Specifications and dimensions are subject to change without notice.

2. PERFORMANCE

2-1 MAXIMUM OUTPUT

The maximum output of an engine is such a standard power as produced by the engine with its throttle valve fully opened after its initial break-in period when all the moving parts are properly worn in. Therefore, a new engine may not produce the maximum output in the beginning because the moving parts are not in a properly worn-in condition.

2-2 MAXIMUM TORQUE

The maximum torque indicates the torque at the output shaft when the engine is producing the maximum output.

2-3 PERFORMANCE CURVES

●EH18V

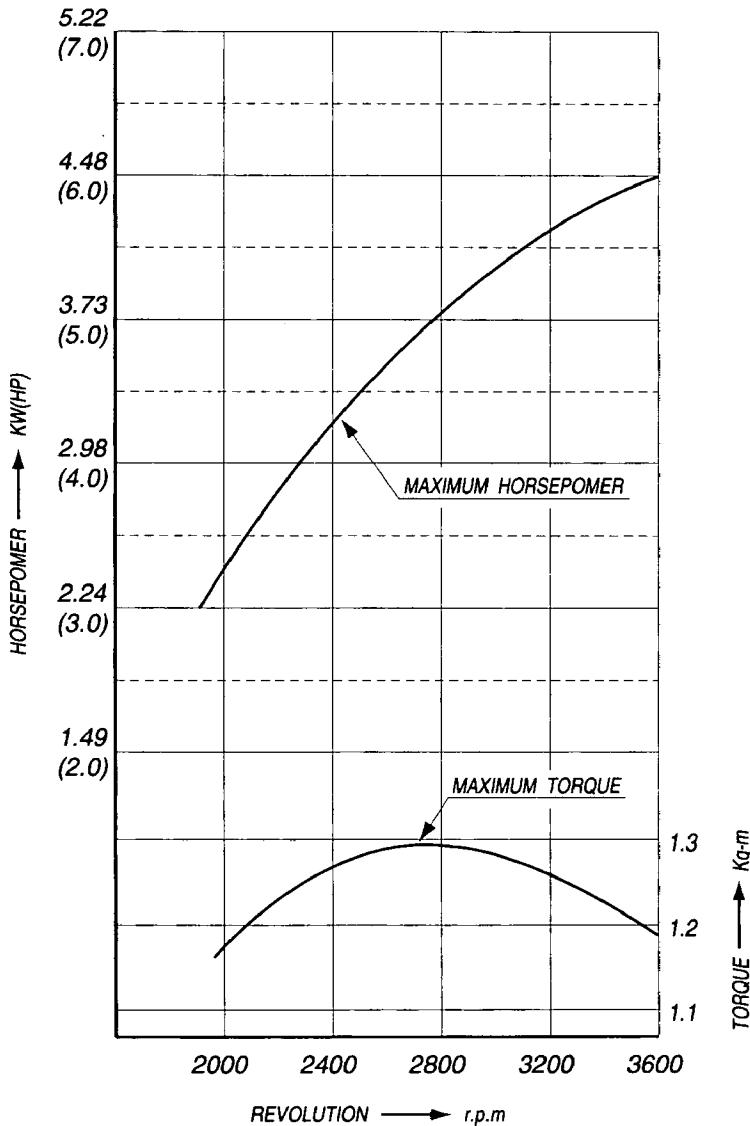

3. FEATURES

1. The overhead valve design offers compactness, light weight and ideal combustion characteristics resulting in more power from less fuel and prolonged engine life.
2. The parts such as a large capacity muffler, dual element air cleaner reduce noise to a minimum level.
3. The automatic decompression system offers easy and sure starting.
4. The muffler and carburetor are located on opposite sides, making the arrangements for cooling air flow much easier in the design of power equipment.
5. The oil pump and oil filter provide excellent lubrication regardless of engine posture during operation.
6. This engine is offered in two stylish versions.
7. The Pro-Poly version engine is covered with a stylishly designed shroud with the fuel tank incorporated into it.
8. The Classic Steel version does not have the shroud or combined fuel tank.

4. GENERAL DESCRIPTION OF ENGINE COMPONENTS

4-1 CYLINDER AND CRANKCASE

The cylinder and crankcase is single piece aluminum diecasting. The cylinder liner, made of special cast iron, is molded into the aluminum casting.

The crankcase has a mounting surface on the output shaft side, where the main bearing cover is attached. (See Fig. 4-1.)

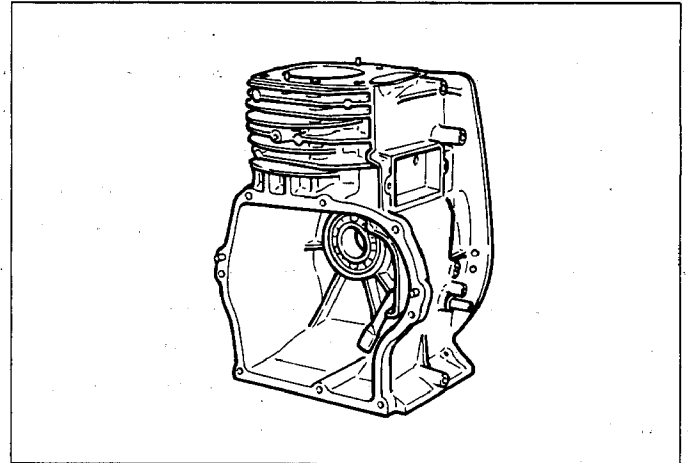

Fig. 4-1

4-2 MAIN BEARING COVER

The main bearing cover is an aluminum diecasting, which is mounted on the output shaft side of the crankcase. Remove the main bearing cover to inspect inside of the engine.

The main bearing cover also functions as an oil pan, with a trochoid oil pump and oil filler. (See Fig. 4-2.)

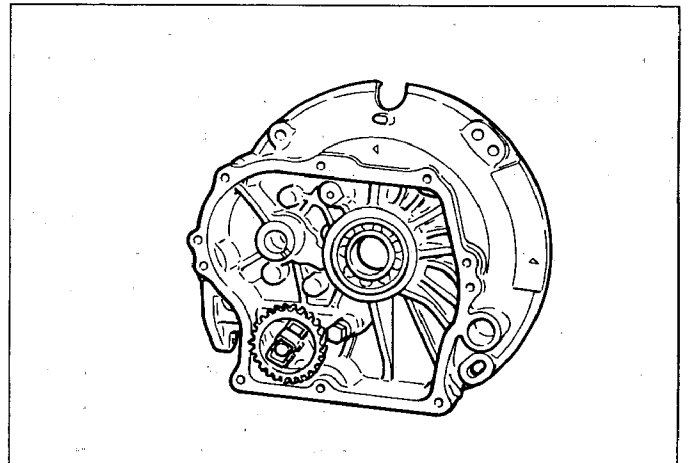

Fig. 4-2

4-3 CRANKSHAFT

The crankshaft is a forged carbon steel, and the crank pin is induction-hardened. The PTO end of the shaft has a crankshaft gear which is pressed into position. (See Fig. 4-3.)

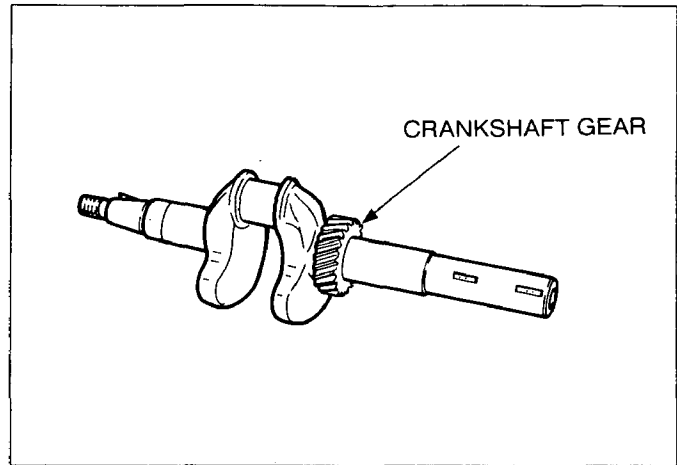

Fig. 4-3

4-4 CONNECTING ROD AND PISTON

The connecting rod is a forged aluminum alloy, and its large and small ends function as bearings. The piston is an aluminum alloy casting, and carries two compression rings and one oil ring. (See Fig. 4-4.)

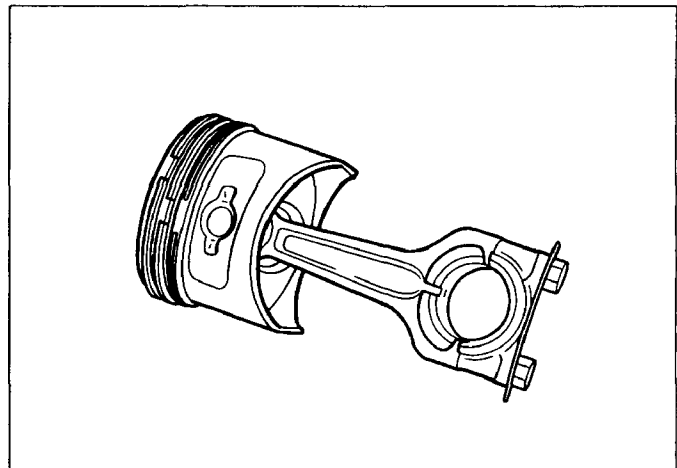

Fig. 4-4

4-5 CAMSHAFT

The camshaft is a hollow shaped and made of special cast iron with the camshaft gear casted together.

A centrifugal decompression lever is assembled on the camshaft. The lubrication oil pump is driven by the groove on the end of the camshaft.

(See Fig. 4-5.)

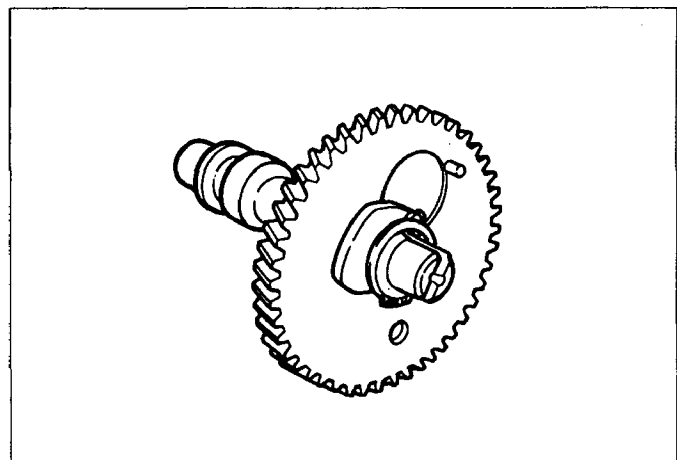

Fig. 4-5

4-6 VALVE ARRANGEMENT

The intake valve is located at flywheel side of the cylinder head.

Hard alloy valve seats are molded in the cylinder head and stellite is fused to the exhaust valve face. The cylinder baffle leads cooling air to the exhaust valve area for the optimum cooling.

(See Fig. 4-6.)

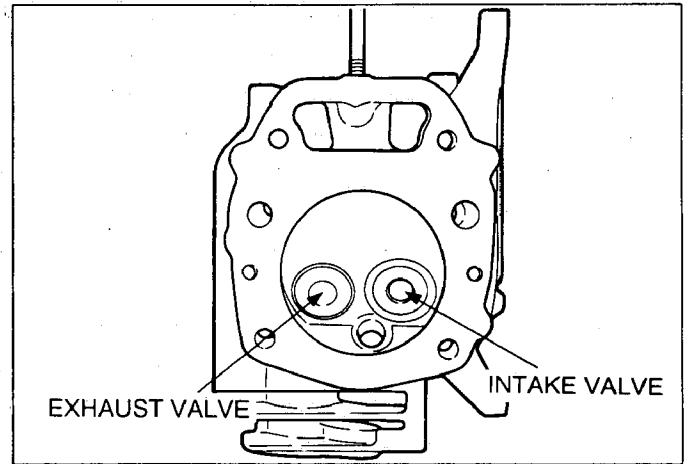

Fig. 4-6

4-7 CYLINDER HEAD

The cylinder head is an aluminum die casting, which utilizes wedge type combustion chamber for the highest combustion efficiency.

(See Fig. 4-7.)

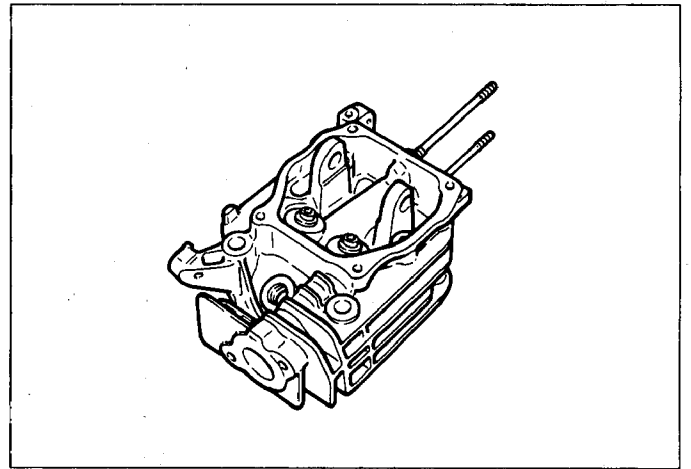

Fig. 4-7

4-8 GOVERNOR SYSTEM

The governor is a centrifugal flyweight type which ensures constant operation at the selected speed against load variations.

The governor gear with governor weights is installed on the bearing cover and driven by the camshaft gear. (See Fig. 4-8.)

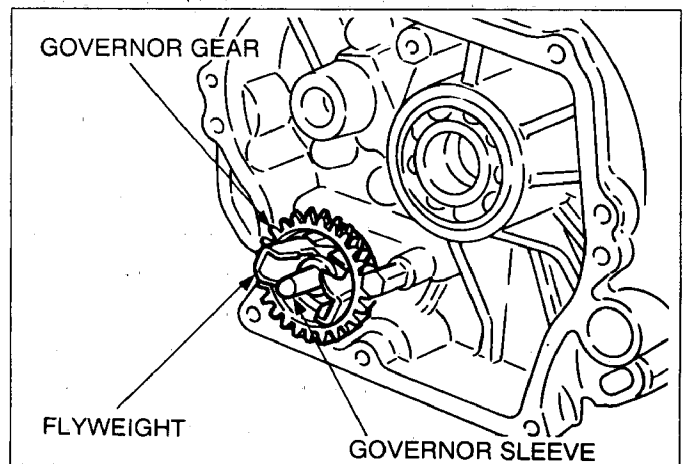

Fig. 4-8

4-9 COOLING SYSTEM

The large fins on the flywheel provide sufficient cooling air capacity for the inlet and exhaust area and cylinder.

The cylinder baffle helps the cooling air flow efficiently.

4-10 LUBRICATION

EH18V has a trochoid pump outside the main bearing cover that is driven by the camshaft.

EH18V uses forced splash type lubrication. (See Fig. 4-9.)

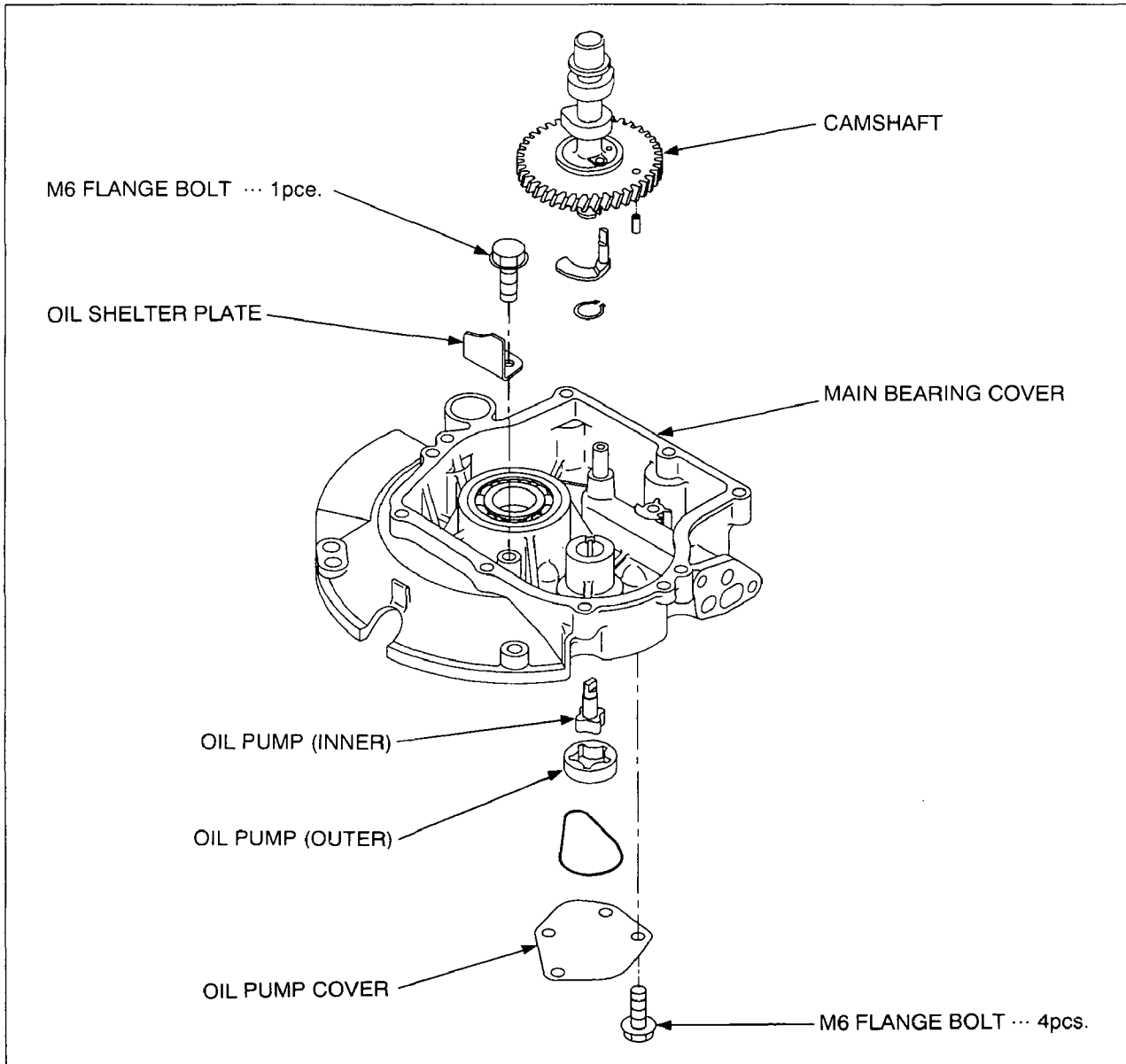

Fig. 4-9

4-11 IGNITION SYSTEM

The ignition system is a transistor controlled magneto ignition system which consists of a flywheel and an ignition coil with a built in transistor mounted on the crankcase.

This system has an automatic ignition timing advancing for easier starting. (See Fig. 4-10.)

For details, refer to page 39, section 6.

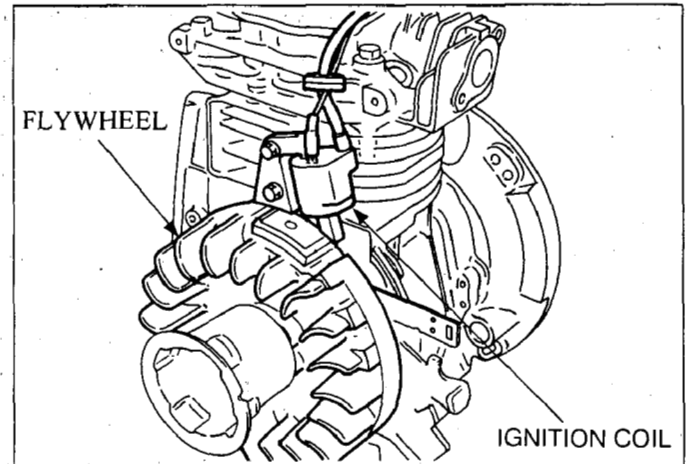

Fig. 4-10

4-12 CARBURETOR

The engines are equipped with a horizontal draft carburetor that has a float controlled fuel system and a fixed main jet.

The carburetors are calibrated carefully for the sure starting, good acceleration, low fuel consumption and sufficient output.

For the details, refer to page 42, section "8 CARBURETOR". (See Fig. 4-11.)

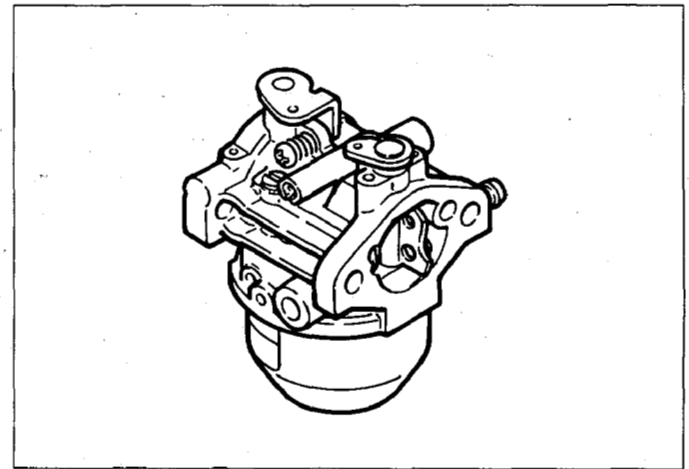

Fig. 4-11

4-13 AIR CLEANER

The air-cleaner is a heavy-duty type with a dual element system. (See Fig. 4-12.)

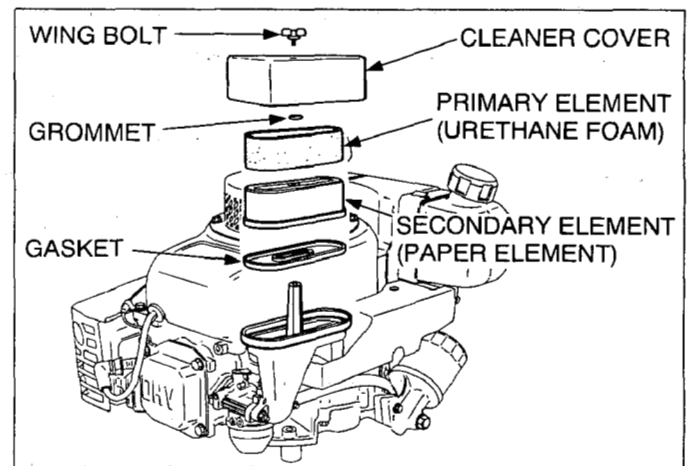

Fig. 4-12

4-14 DECOMPRESSION SYSTEM

An automatic decompression mechanism which opens exhaust valve before the piston reaches compression top is assembled on the camshaft for easy starting. (See Fig. 4-13)

For details, refer to page 41, section 7.

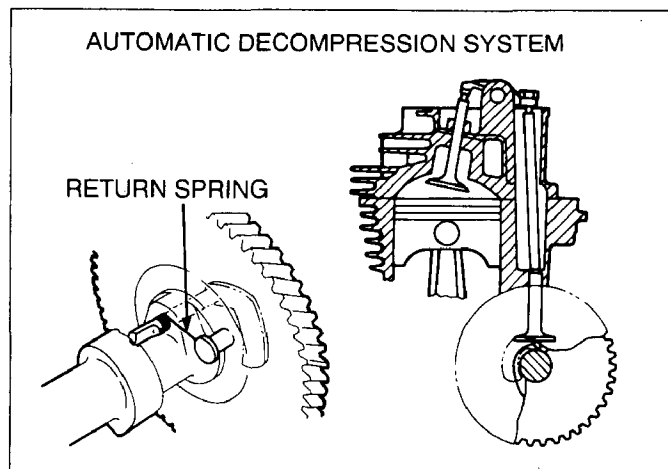
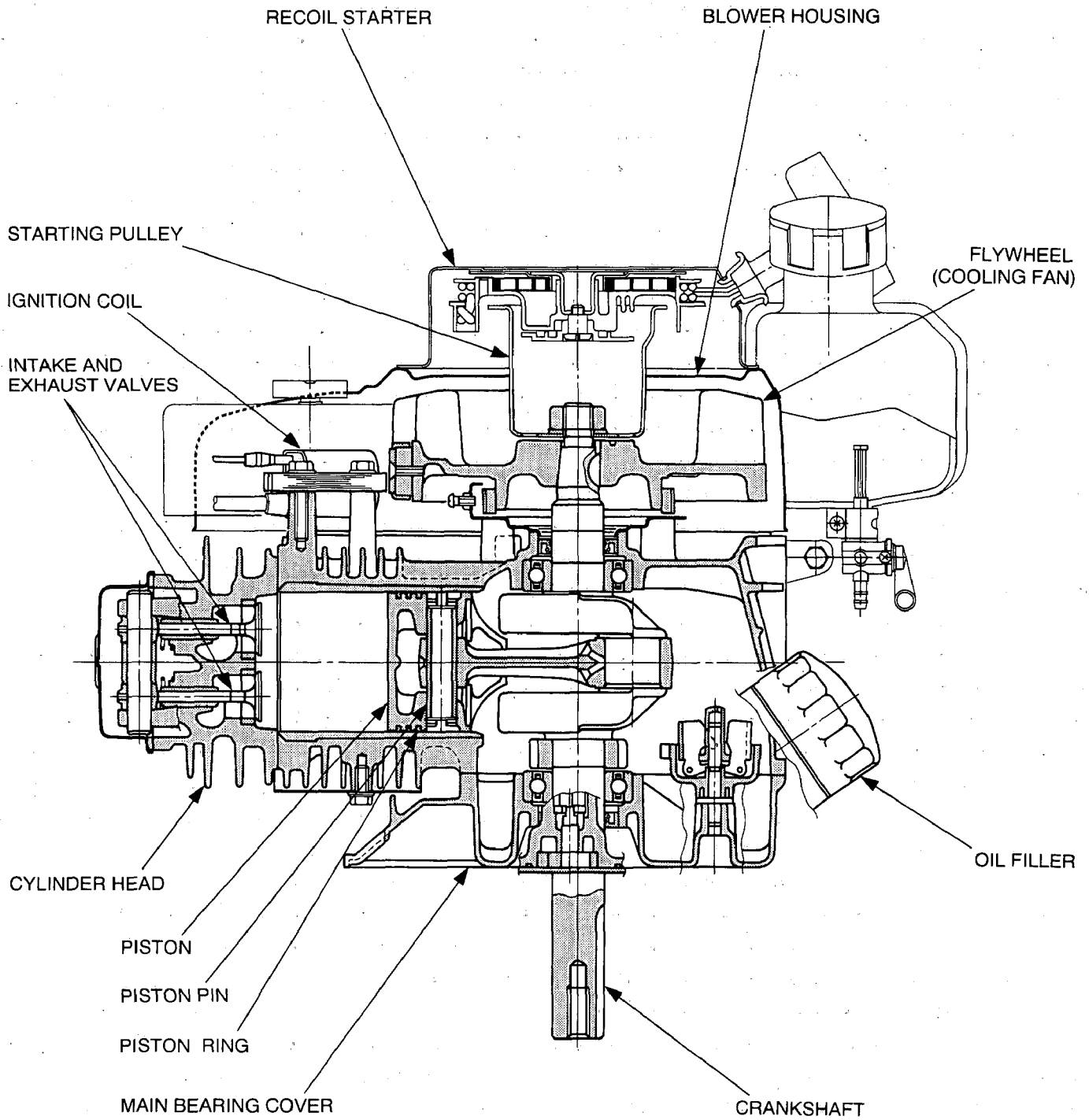
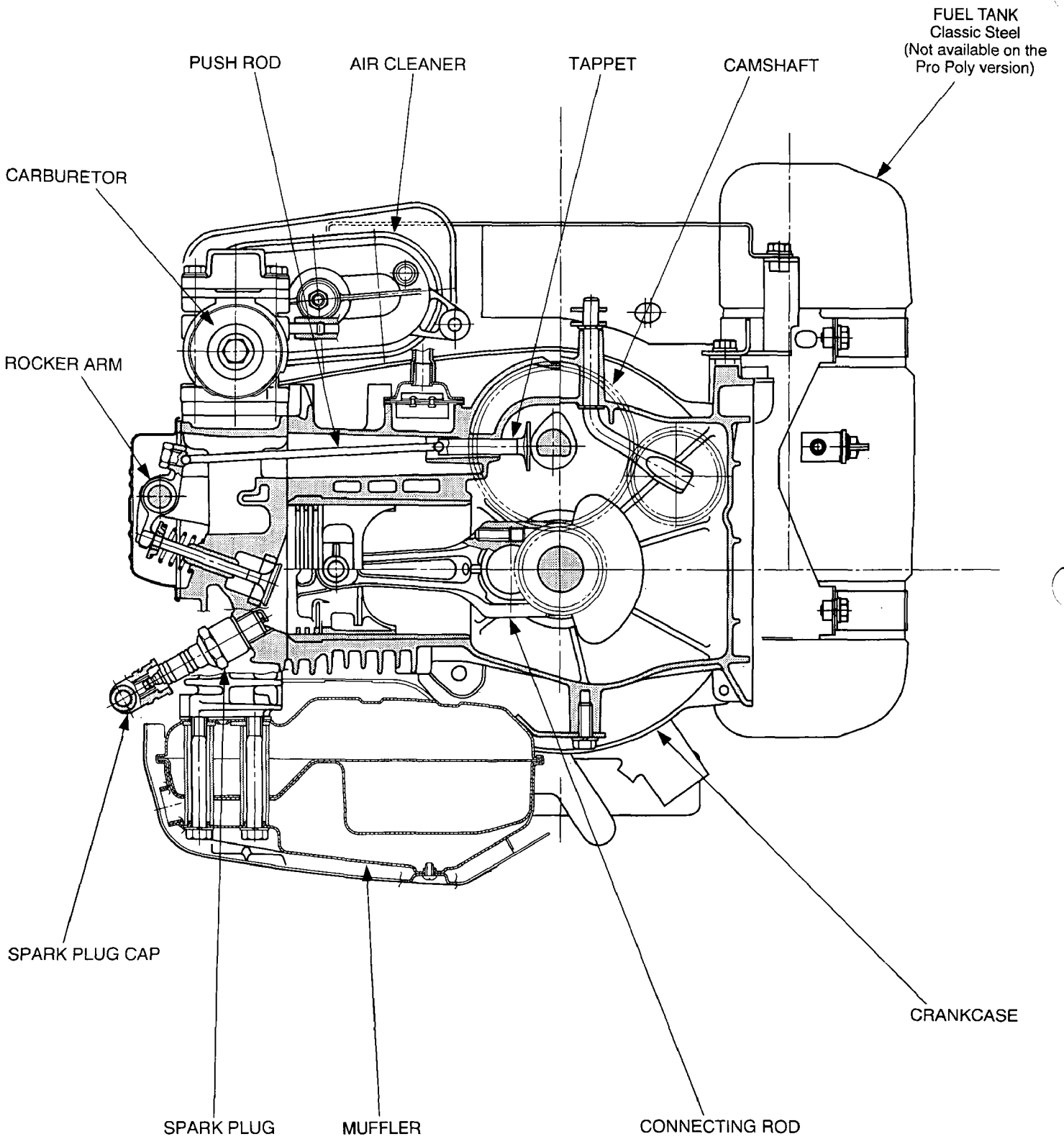

Fig. 4-13

4-15 SECTIONAL VIEW OF ENGINE





5. DISASSEMBLY AND REASSEMBLY

5-1 PREPARATIONS AND SUGGESTIONS

- 1) When disassembling the engine, remember the locations of the individual parts so that they can be reassembled correctly. If you are uncertain of identifying some parts, it is suggested that tags be attached to them.
- 2) Have boxes ready to keep disassembled parts by group.
- 3) To prevent missing and misplacing, temporarily assemble each group of disassembled parts.
- 4) Carefully handle disassembled parts, and clean them with oil if necessary.
- 5) Use the correct tools in the correct way.

5-2 SPECIAL TOOLS

Tool No.	Tool	Use
228-95003-07	Piston ring compressor	For placing piston ring
Market parts	Flywheel puller	For pulling off the flywheel

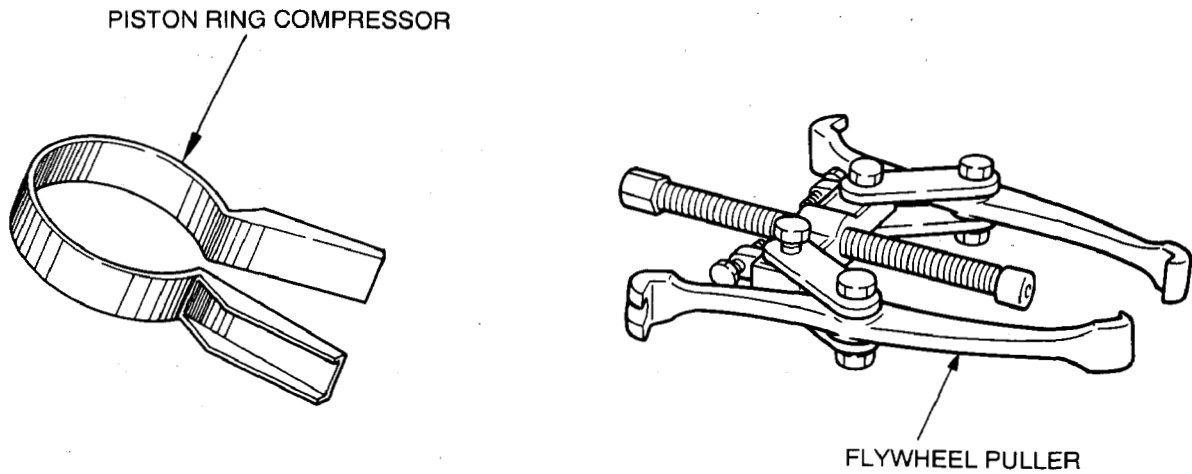

Fig. 5-1

5-3 DISASSEMBLY PROCEDURES (CLASSIC STEEL) / (PRO POLY)

Step	Part to remove	Procedures	Remarks	Tool
1	Spark plug	Remove spark plug cap and spark plug.		19mm plug wrench
2	Oil drain, oil filter and bracket	(1) Remove oil gauge. (2) Remove oil drain plug and drain oil. (3) Remove oil filter. (4) Remove oil filter bracket. M6×12mm bolt 2pcs.		14mm box wrench 10mm box wrench

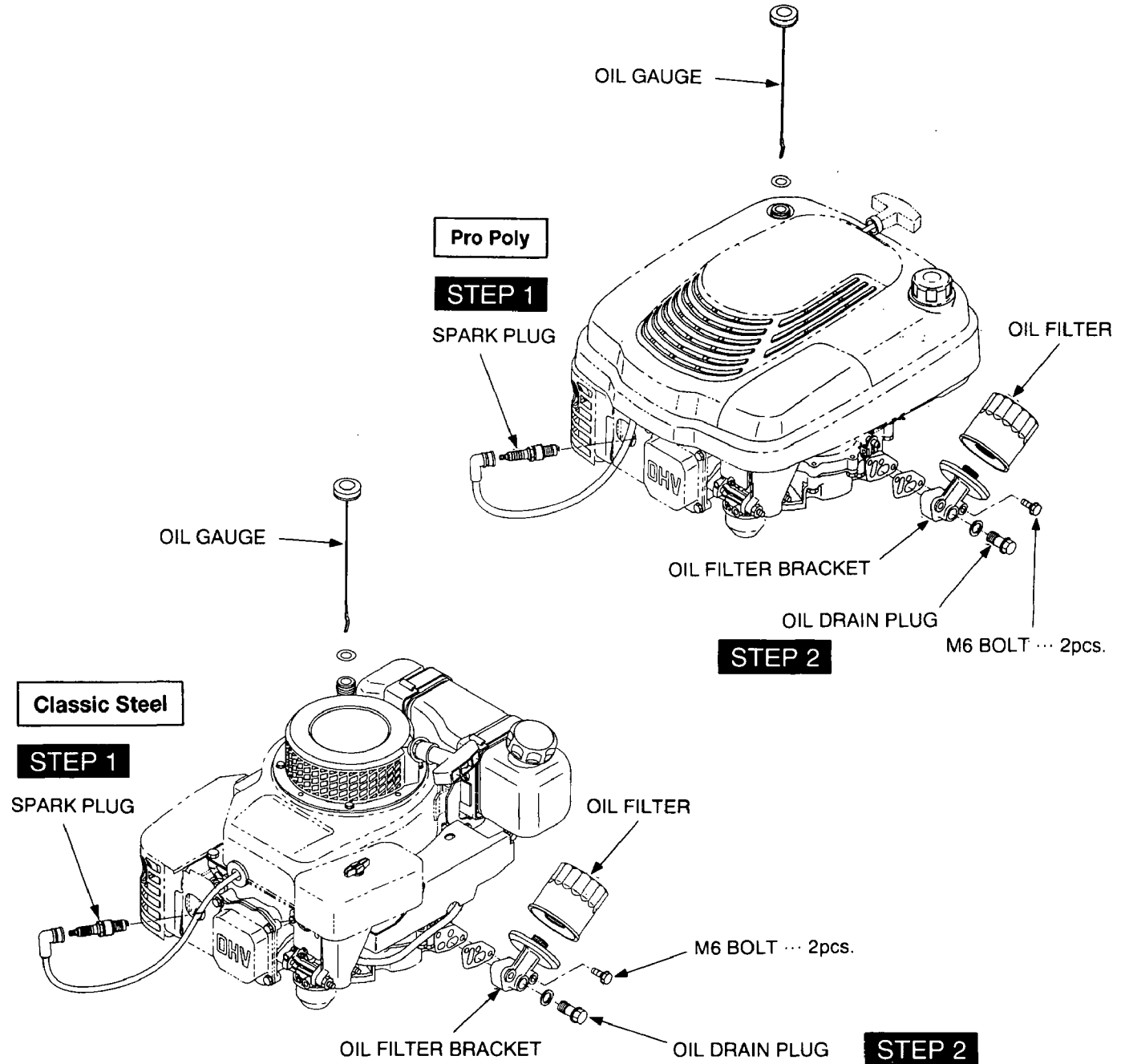

Fig. 5-2

5-3 DISASSEMBLY PROCEDURES (CLASSIC STEEL) – CONTINUED

Step	Part to remove	Procedures	Remarks	Tool
3	Recoil starter	Remove recoil starter from the engine. M6×8mm bolt 4pcs.		10mm box wrench
4	Fuel tank	(1) Remove fuel tank. M6×12mm bolt 2pcs. (2) Remove fuel pipe from the fuel tank. (3) Remove side guard. M6×12mm bolt 2pcs. (4) Remove bracket (fuel tank) M6×14mm bolt 1pce. (5) Remove cover (stop switch).		

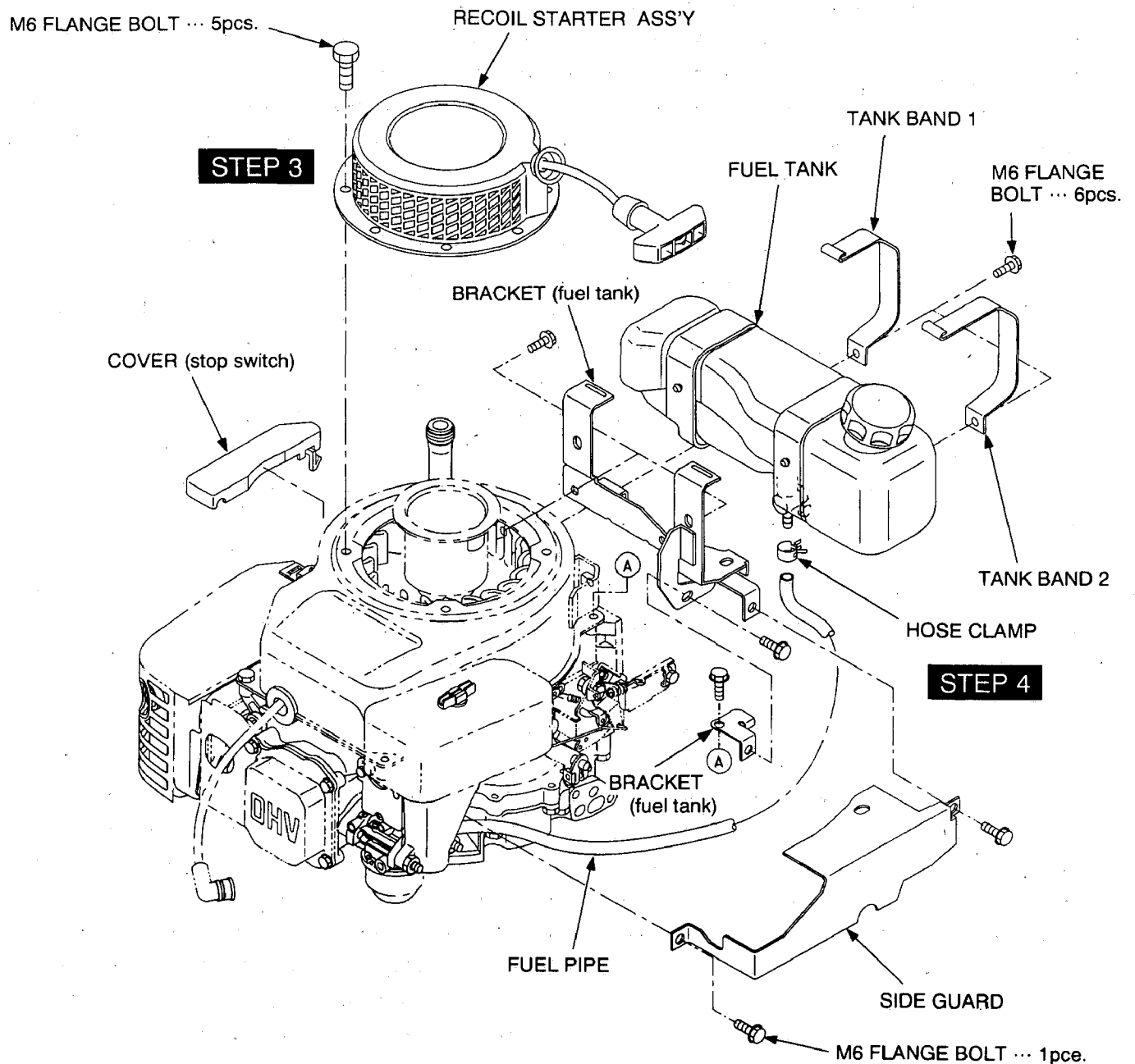

Fig. 5-3

5-3 DISASSEMBLY PROCEDURES (CLASSIC STEEL) – CONTINUED

Step	Part to remove	Procedures	Remarks	Tool
5	Air cleaner	(1) Remove air cleaner cover and air cleaner element M6 wing bolt 1pce. (2) Remove breather hose from cleaner base and crankcase. (3) Remove air cleaner base from air cleaner bracket. M6×12mm bolt 1pce. (4) Remove cleaner base and gasket (air cleaner) from carburetor. M6 nut 2pcs. (5) Remove bracket (A/C) from the engine. M6×12mm bolt 1pce. (6) Remove bracket (A/C cover) M6×14mm bolt 1pce. M6×14mm tapping bolt 1pce.		10mm box wrench 10mm box wrench 10mm box wrench 10mm box wrench

PROCEED TO STEP 7 OF DISASSEMBLY PROCEDURES

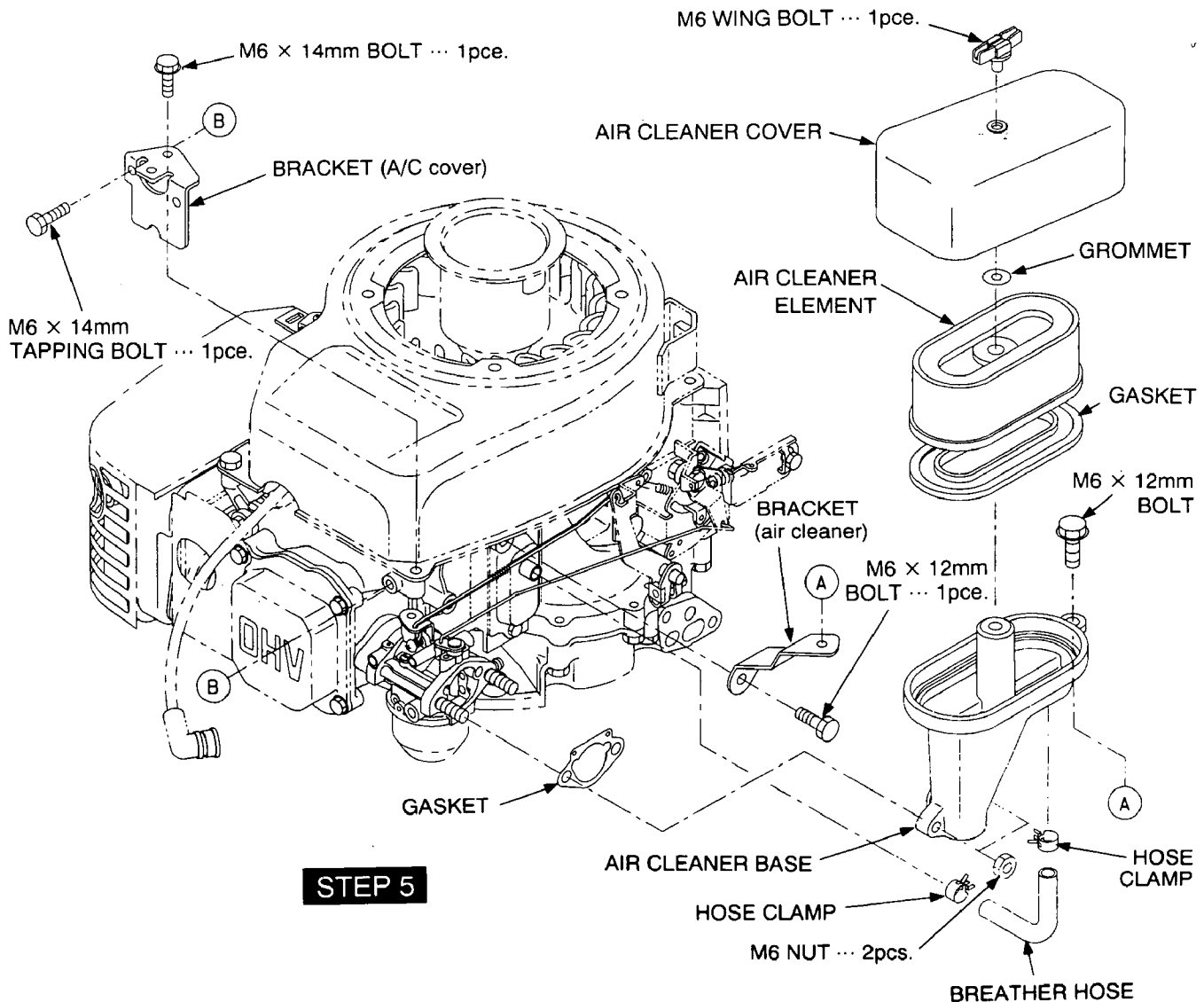

Fig. 5-4

5-3 DISASSEMBLY PROCEDURES (PRO POLY) – CONTINUED

Step	Part to remove	Procedures	Remarks	Tool
3	Top cover	Remove top cover from the engine. M5×16mm tapping screw 2pcs.		(+) driver
4	Recoil starter	Remove recoil starter from the engine. M6×12mm bolt 4pcs.		10mm box wrench
5	Air cleaner cover and engine shroud (with fuel tank)	(1) Remove air cleaner cover and element M6 wing bolt 1pce. (2) Remove fuel pipe from the fuel tank (engine shroud). (3) Remove engine shroud. M6×12mm bolt 1pce. (4) Remove bracket (A/C cover) M6×14mm bolt 1pce. M6×14mm tapping bolt 1pce.		10mm box wrench 10mm box wrench

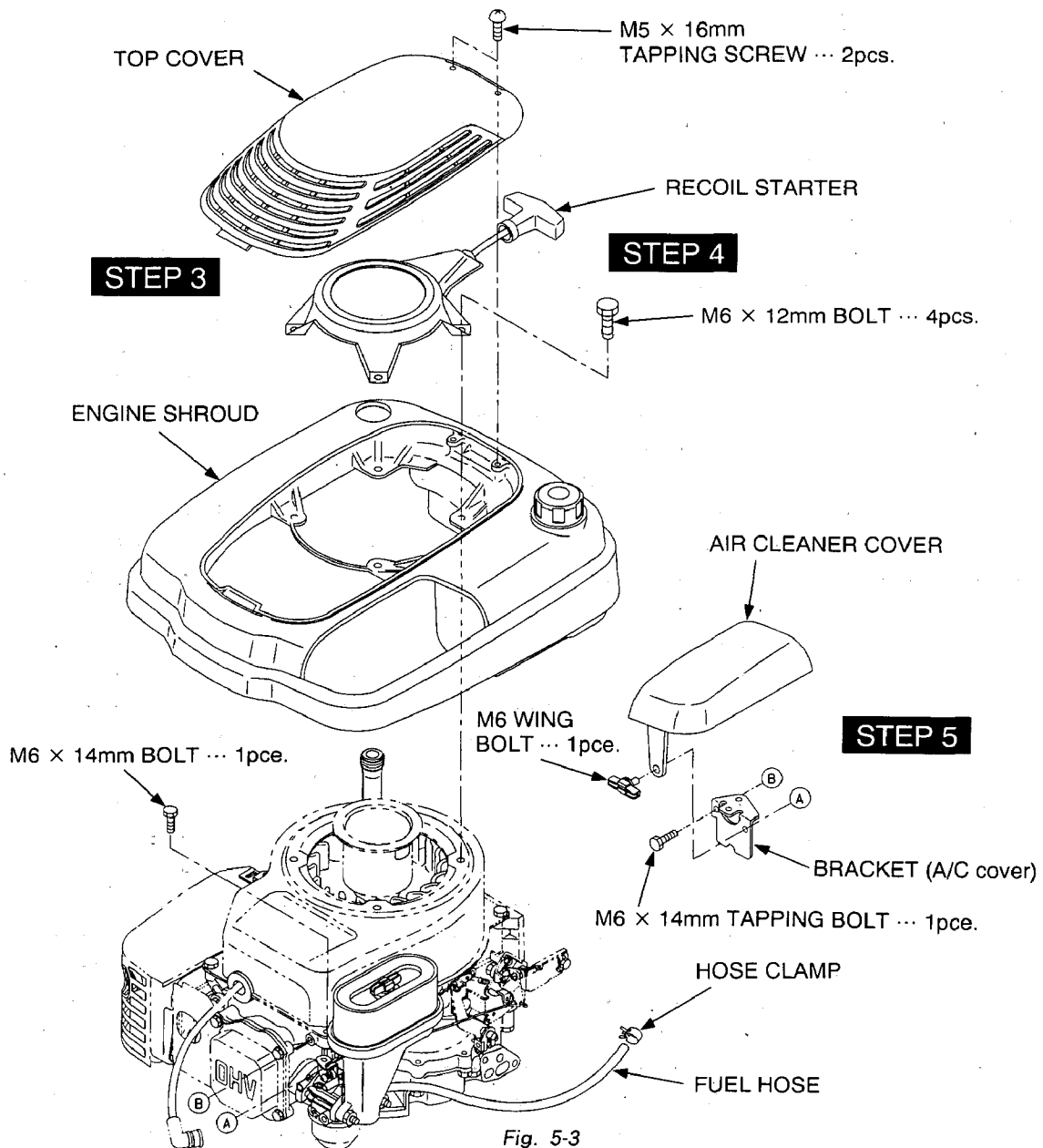

Fig. 5-3

5-3 DISASSEMBLY PROCEDURES (PRO POLY) – CONTINUED

Step	Part to remove	Procedures	Remarks	Tool
6	Air cleaner	(1) Remove air cleaner element M6 wing bolt 1pce. (2) Remove breather hose from cleaner base and crankcase. (3) Remove air cleaner base from air cleaner bracket. M6×12mm bolt 1pce. (4) Remove cleaner base and gasket (air cleaner) from carburetor. M6 nut 2pcs. (5) Remove bracket (A/C) from the engine. M6×12mm bolt 1pce.		10mm box wrench 10mm box wrench 10mm box wrench

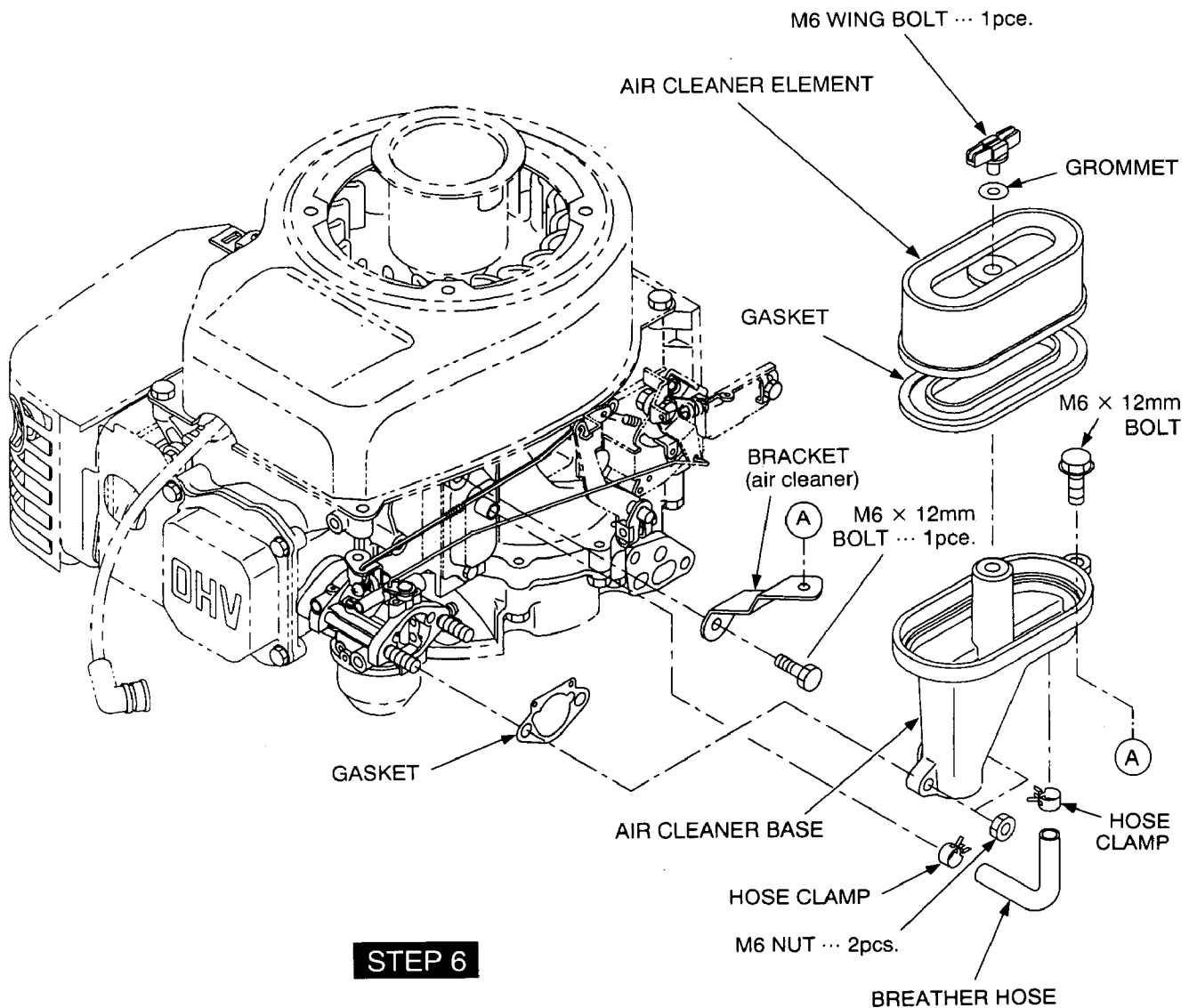

Fig. 5-4

5-3 DISASSEMBLY PROCEDURES (CLASSIC STEEL) / (PRO POLY)

Step	Part to remove	Procedures	Remarks	Tool
7	Speed control	(1) Remove speed control assembly from the crank case, then remove governor spring from the governor lever. M6×12mm bolt 2pcs. (2) Remove choke rod from speed control assembly, then remove choke rod from choke shaft of the carburetor.		10mm box wrench
8	Governor lever	(1) Remove governor lever from the governor shaft. M6×25mm bolt and washer assy 1pce. (2) Remove rod spring and governor rod from governor lever, then remove rod spring and governor rod from throttle shaft of the carburetor.		10mm box wrench

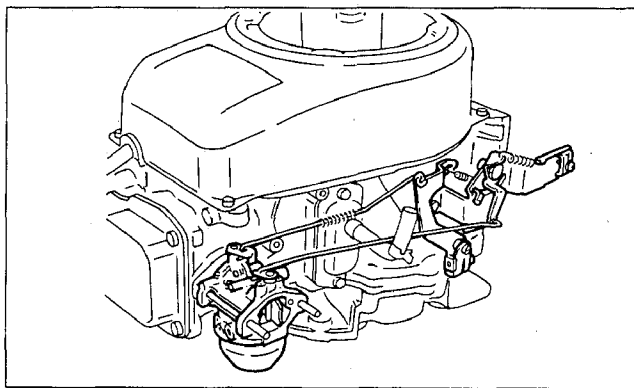

Fig. 5-6

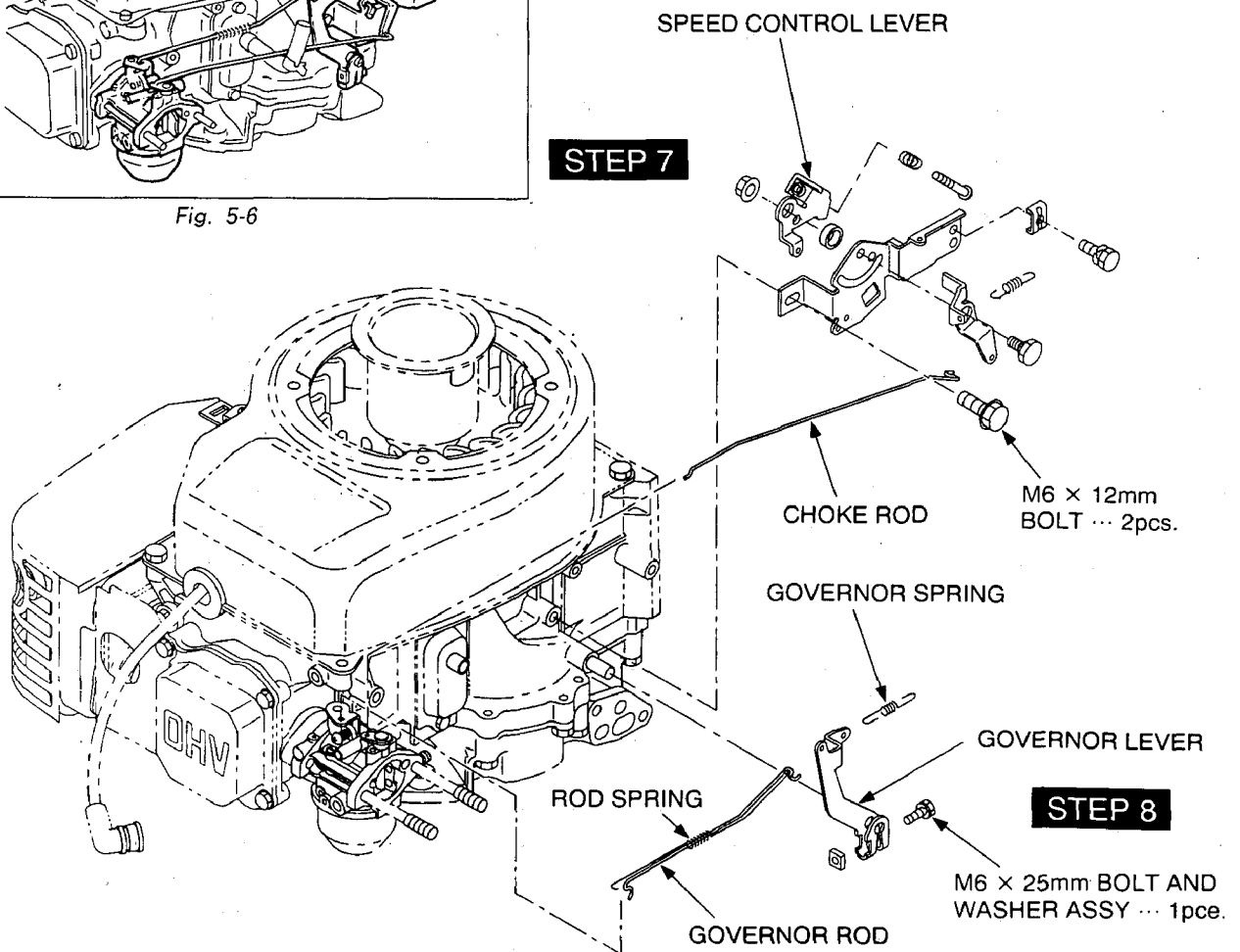

Fig. 5-5

Step	Part to remove	Procedures	Remarks	Tool
9	Carburetor	(1) Remove carburetor from stud bolts. (2) Remove gasket and insulator from stud bolts.		
10	Muffler	(1) Remove muffler cover from muffler. M5×10mm tapping screw 3pcs. (2) Remove muffler and gasket. (muffler) M8×70mm bolt and washer assy 2pcs. M8×16mm bolt and washer assy 1pce.		(+) driver 12mm box wrench

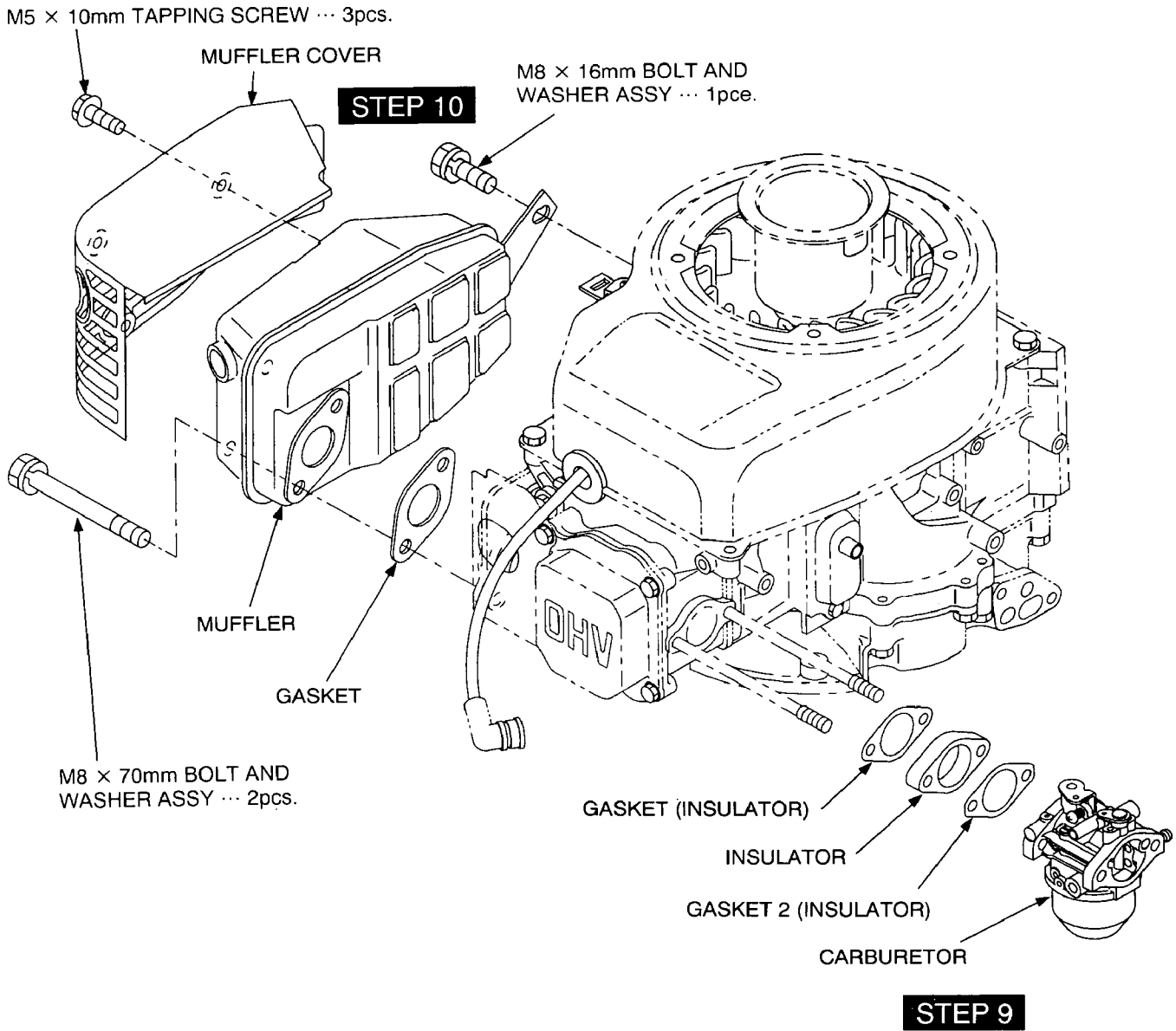

Fig. 5-7

Step	Part to remove	Procedures	Remarks	Tool
11	Oil filler	Remove the clamp from oil filler, and remove oil filler bracket. M6×12mm bolt 1 pce.		10mm box wrench
12	Blower housing	Remove the blower housing from the crankcase. M6×12mm bolt 2pcs. M6×14mm bolt 1pce.		10mm box wrench
13	Ignition coil	(1) Disconnect stop switch wire from stop switch. (2) Remove ignition coil from crankcase. M6×30mm bolt 2pcs.		10mm box wrench

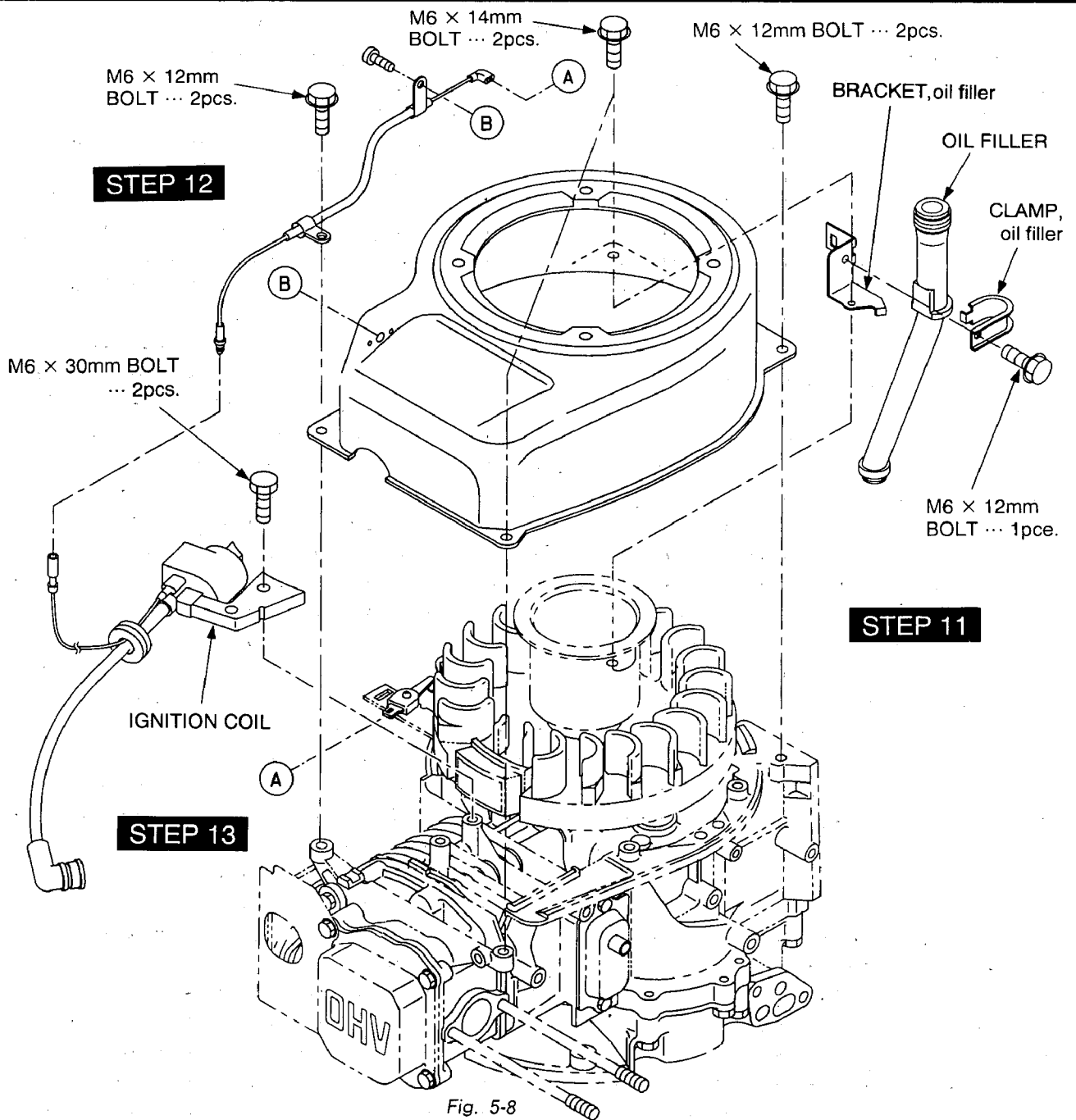

Fig. 5-8

Step	Part to remove	Procedures	Remarks	Tool
14	Flywheel	(1) Remove starter pulley from flywheel. M14 nut 1pce. (2) Remove flywheel from crankshaft. (See Fig. 5-11.) (3) Remove key from crankshaft.		18mm box wrench (-) driver

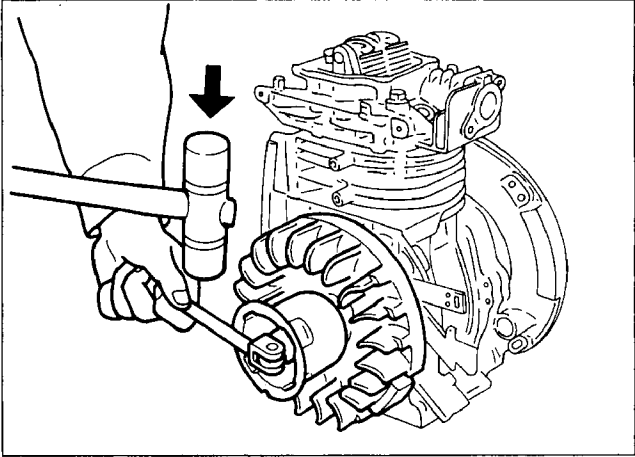
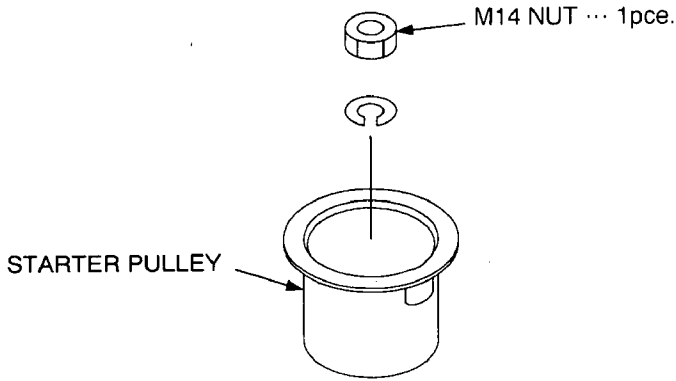
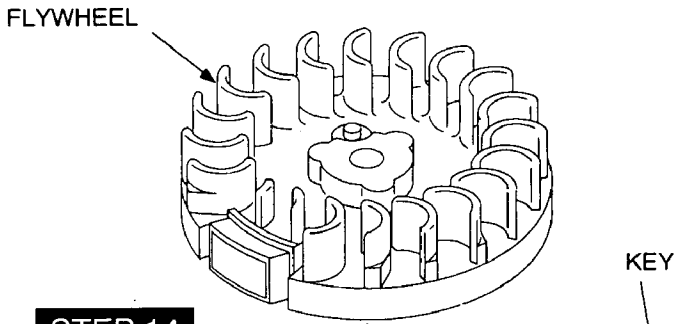

Fig. 5-10



STEP 14

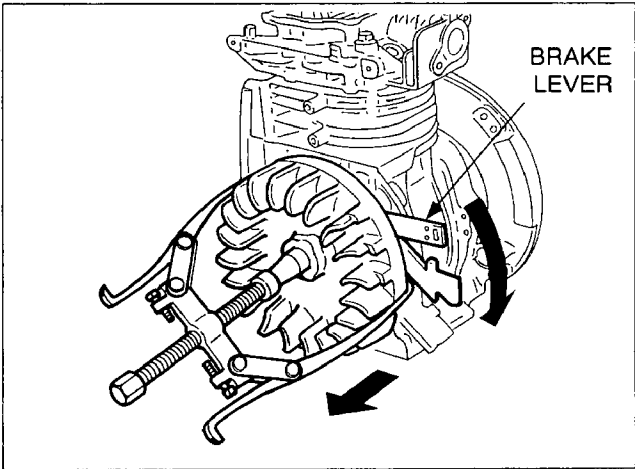

Fig. 5-11

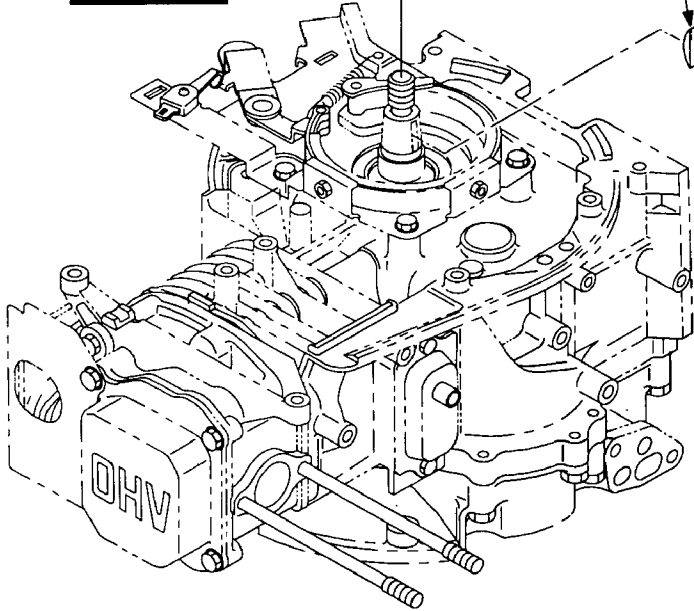

Fig. 5-9

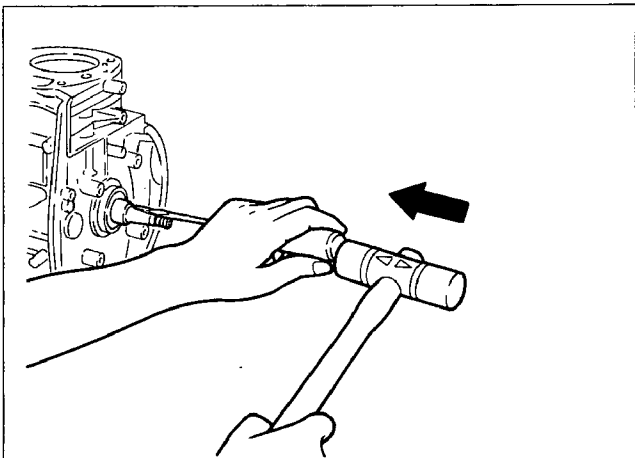

Fig. 5-12

Step	Part to remove	Procedures	Remarks	Tool
15	Brake assy	(1) Remove brake assy. M6×12mm bolt 4pcs.		10mm box wrench

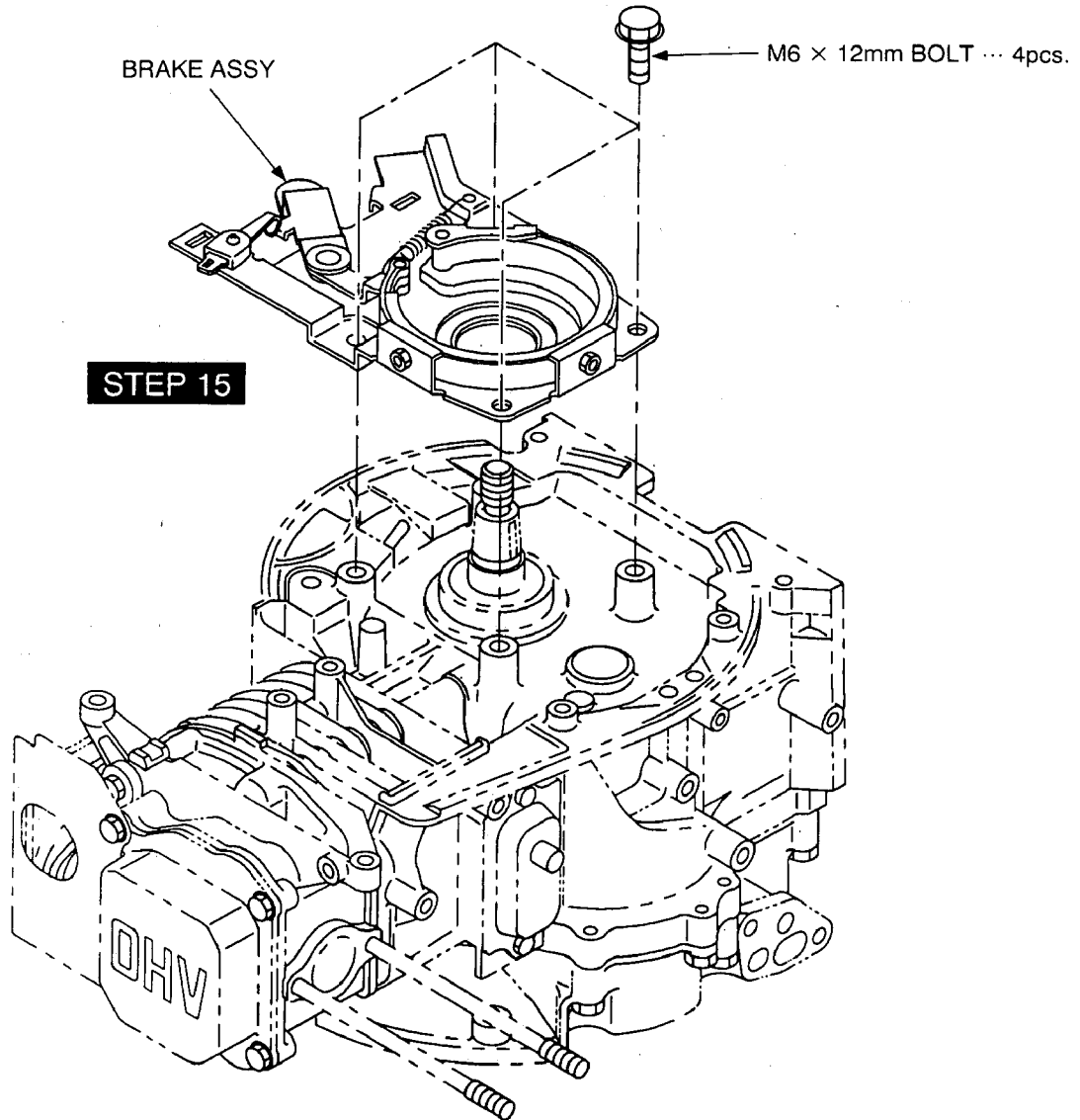

Fig. 5-13

Step	Part to remove	Procedures	Remarks	Tool
16	Cylinder	(1) Remove cylinder baffle. M6×8mm bolt 1pce.		10mm box wrench
17	Cylinder head	(1) Remove rocker cover and guide plate from cylinder head. M6×12mm bolt 4pcs. (2) Loosen lock nut for rocker arm adjusting screw. M8 lock nut 2pcs. (3) Slide off rocker arm shaft from the holder to the flywheel side, remove rocker arms. (See Fig. 5-15.) (4) Remove push rods. (5) Remove cylinder head and gasket. M8×65mm bolt 2pcs. M8×40mm bolt 1pce. M8 flange nut 1pce.		10mm box wrench 12mm box wrench 12mm box wrench

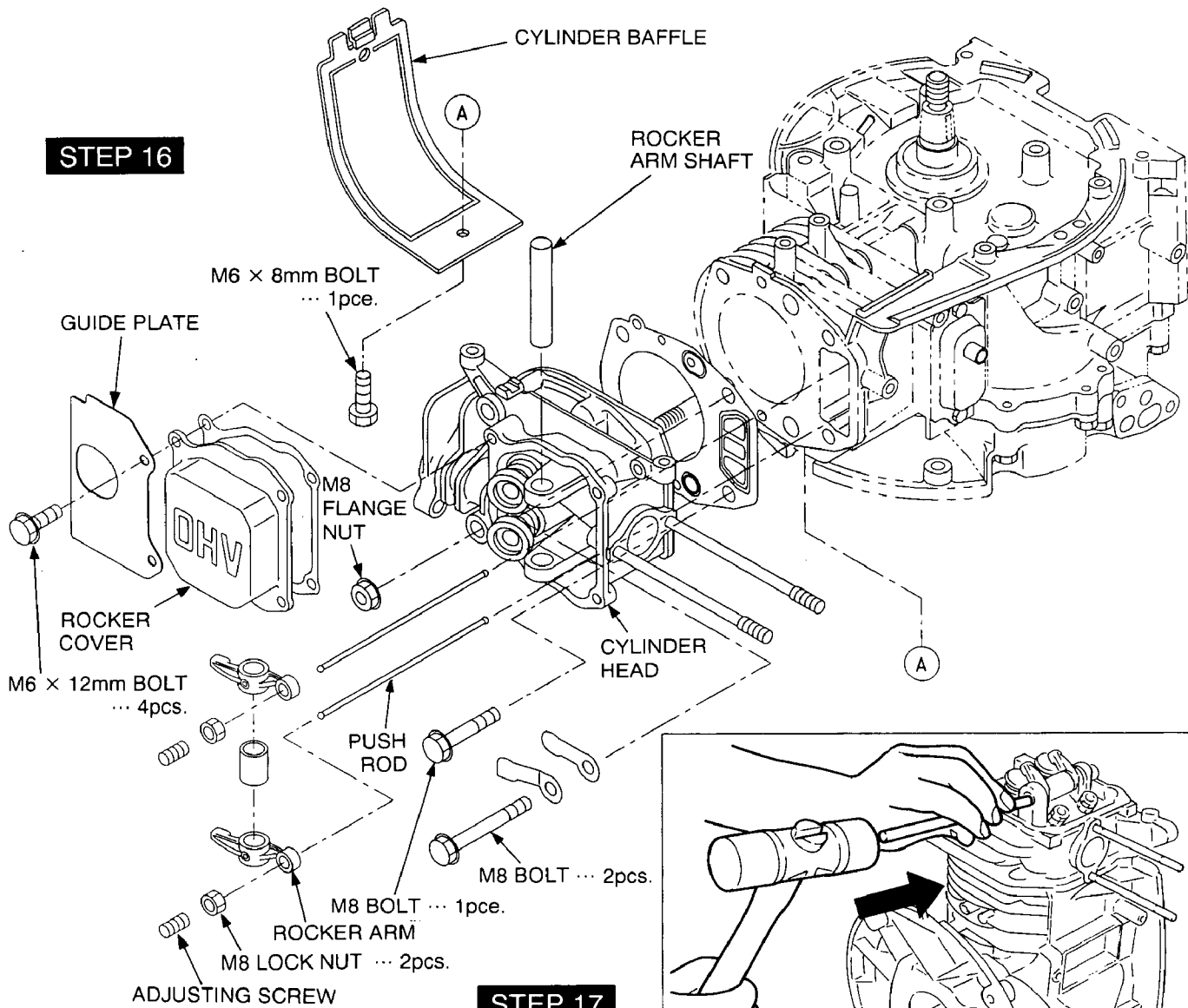

Fig. 5-14

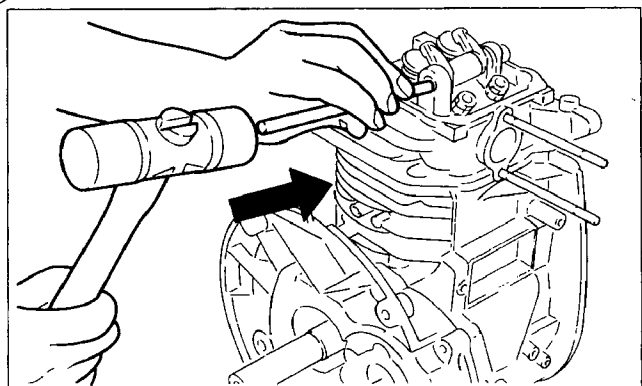

Fig. 5-15

Step	Part to remove	Procedures	Remarks	Tool
18	Intake and exhaust valve	(1) Press down spring retainer and slide it to release from the groove of valve stem, then remove spring retainer and valve spring. (See Fig. 5-16.) (2) Remove intake and exhaust valves from cylinder head.	Clean carbon and gum deposits from the valves, valve seats, ports and guides. Inspect valves, valve seats and guides.	
19	Breather	(1) Remove breather cover. M6×12mm bolt ... 2pcs. Remove gasket (tappet cover), breather plate and gasket (breather plate).		10mm box wrench

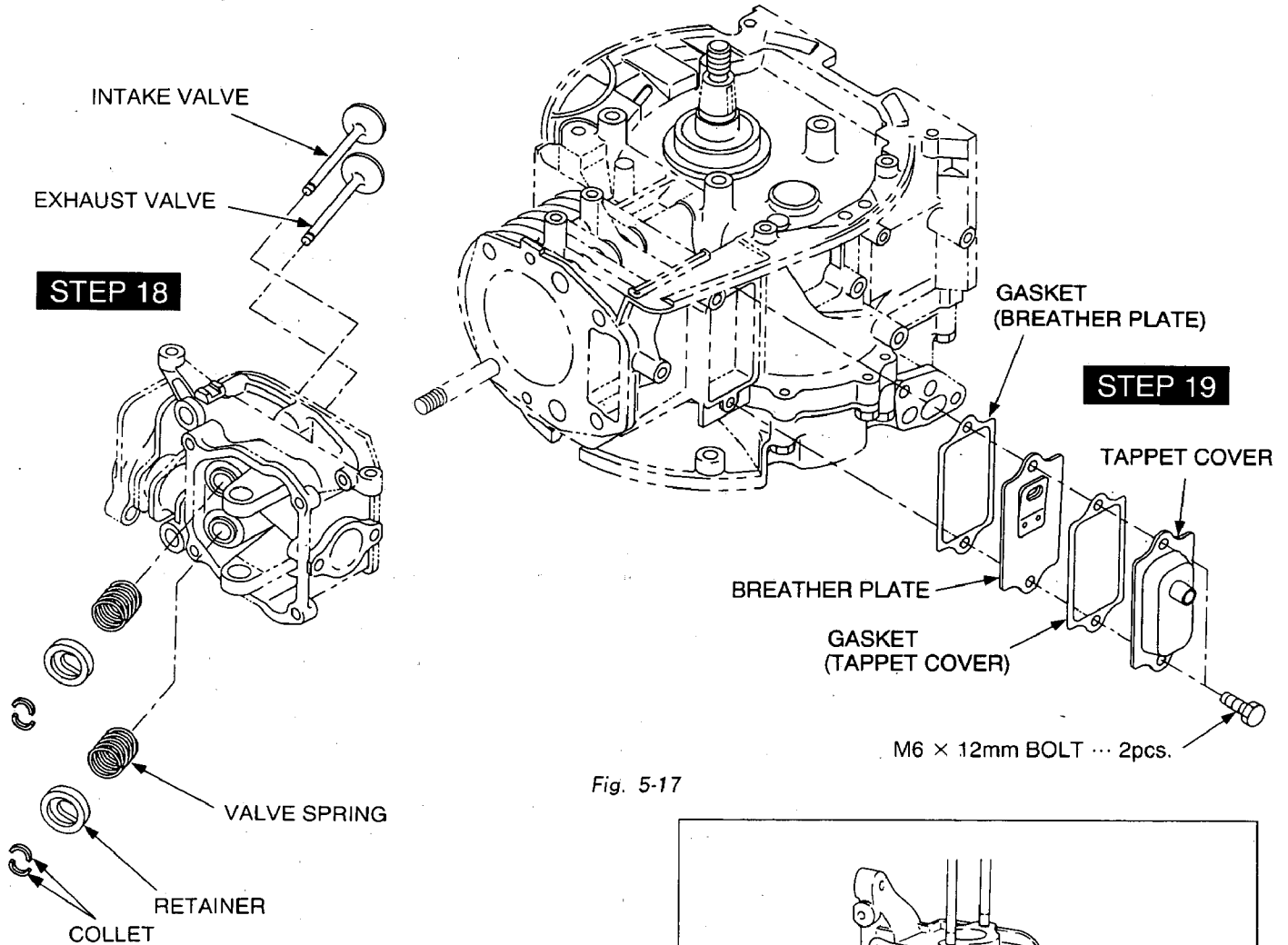

Fig. 5-17

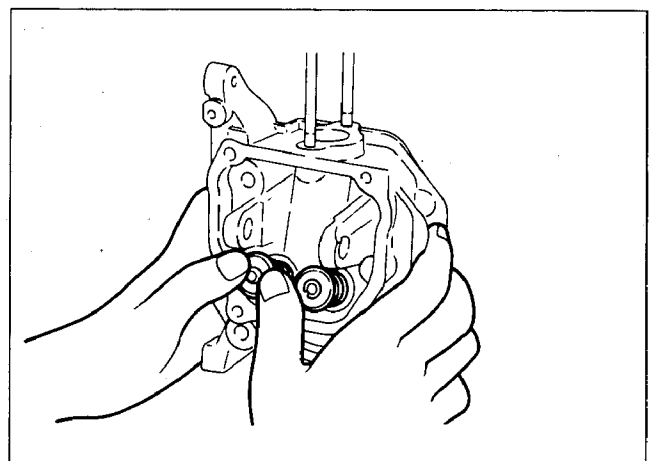

Fig. 5-16

Step	Part to remove	Procedures	Remarks	Tool
20	Main bearing cover	(1) Remove main bearing cover. (See Fig. 5-18.) M6×30mm bolt and washer assy 8pcs.	Do not lose spacer for crankshaft.	10mm box wrench
21	Oil pump	(1) Remove oil pump cover from main bearing cover. M6×12mm bolt 4pcs. (2) Remove oil pump (Inner) and oil pump (Outer).		10mm box wrench

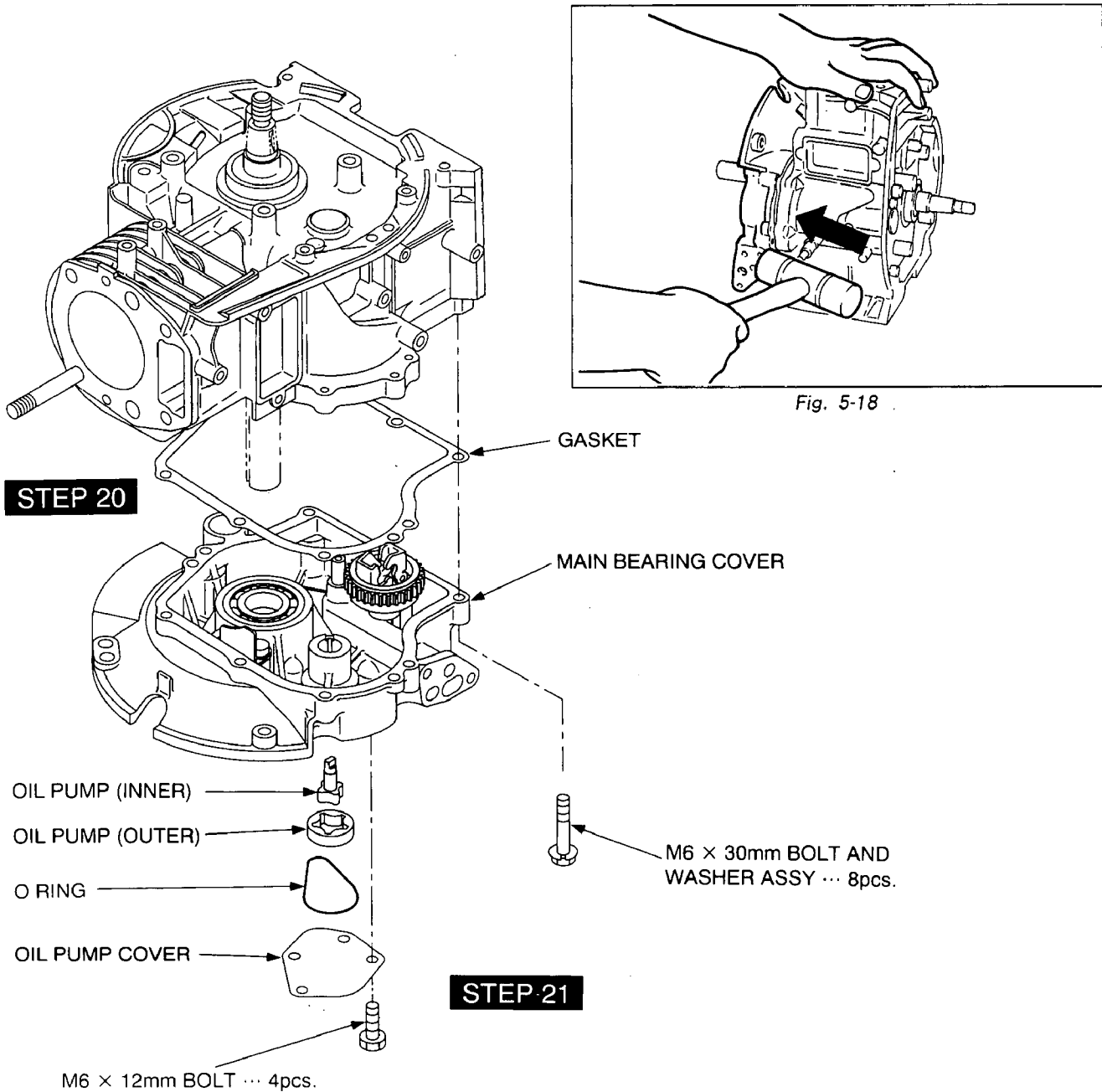

Fig. 5-19

Step	Part to remove	Procedures	Remarks	Tool
22	Camshaft and tappets	(1) Remove camshaft from crankcase. (See Fig. 5-20.) (2) Remove tappets from crankcase.	To prevent the tappets from getting damages, put the crankcase cylinder side down. (See Fig. 5-20.) Tappet must be installed in their original position. Mark tappets prior to removal to prevent error.	

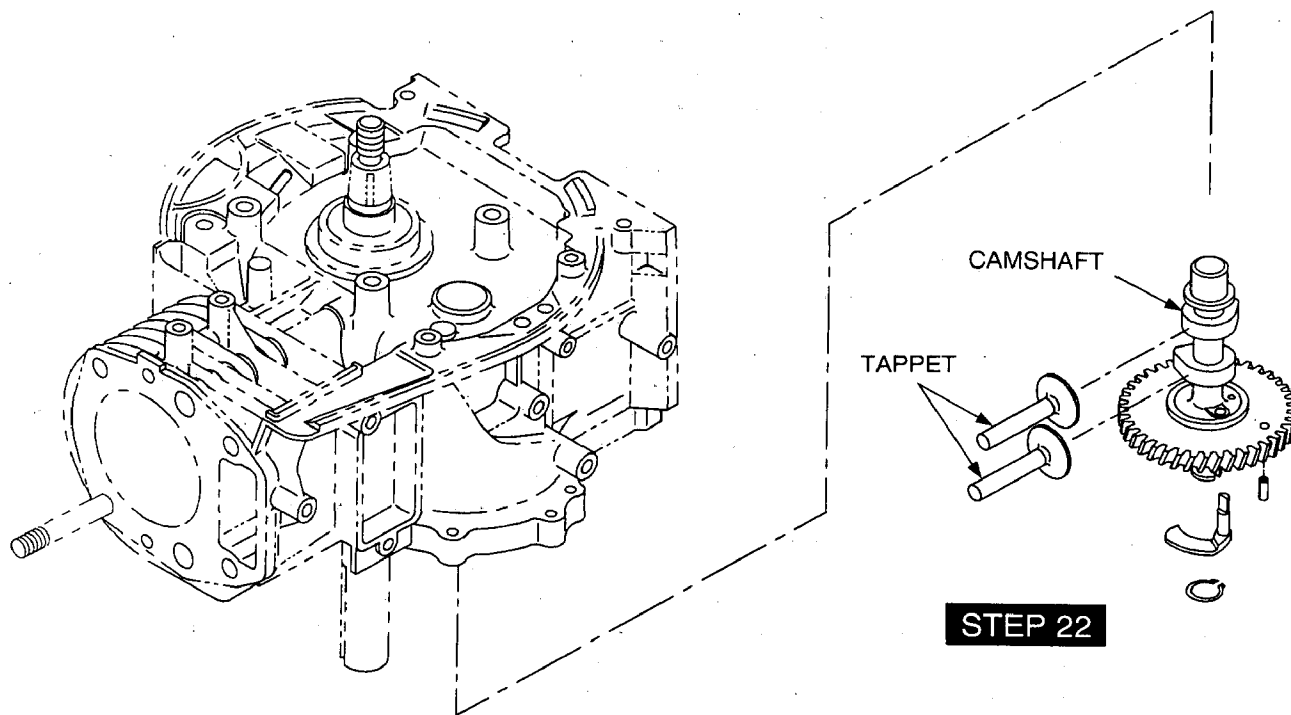

Fig. 5-21

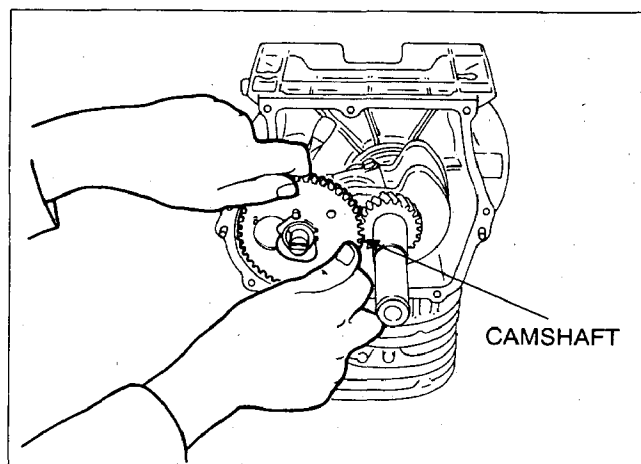

Fig. 5-20

Step	Part to remove	Procedures	Remarks	Tool
23	Connecting rod and piston	(1) Remove connecting rod bolts and connecting rod cap. Connecting rod bolt 2pcs. (2) Turn crankshaft until piston is at top dead center, push out connecting rod and piston assembly through top of cylinder. (3) Remove clips and piston pin to remove connecting rod from piston. (4) Remove piston rings from piston.	Scrape off all carbon deposits that might interfere with removal of piston from upper end of cylinder.	10mm box wrench Ring expander
24	Crankshaft	(1). Tap lightly on flywheel end of crankshaft to remove from crankcase. (See Fig.5-22.)		

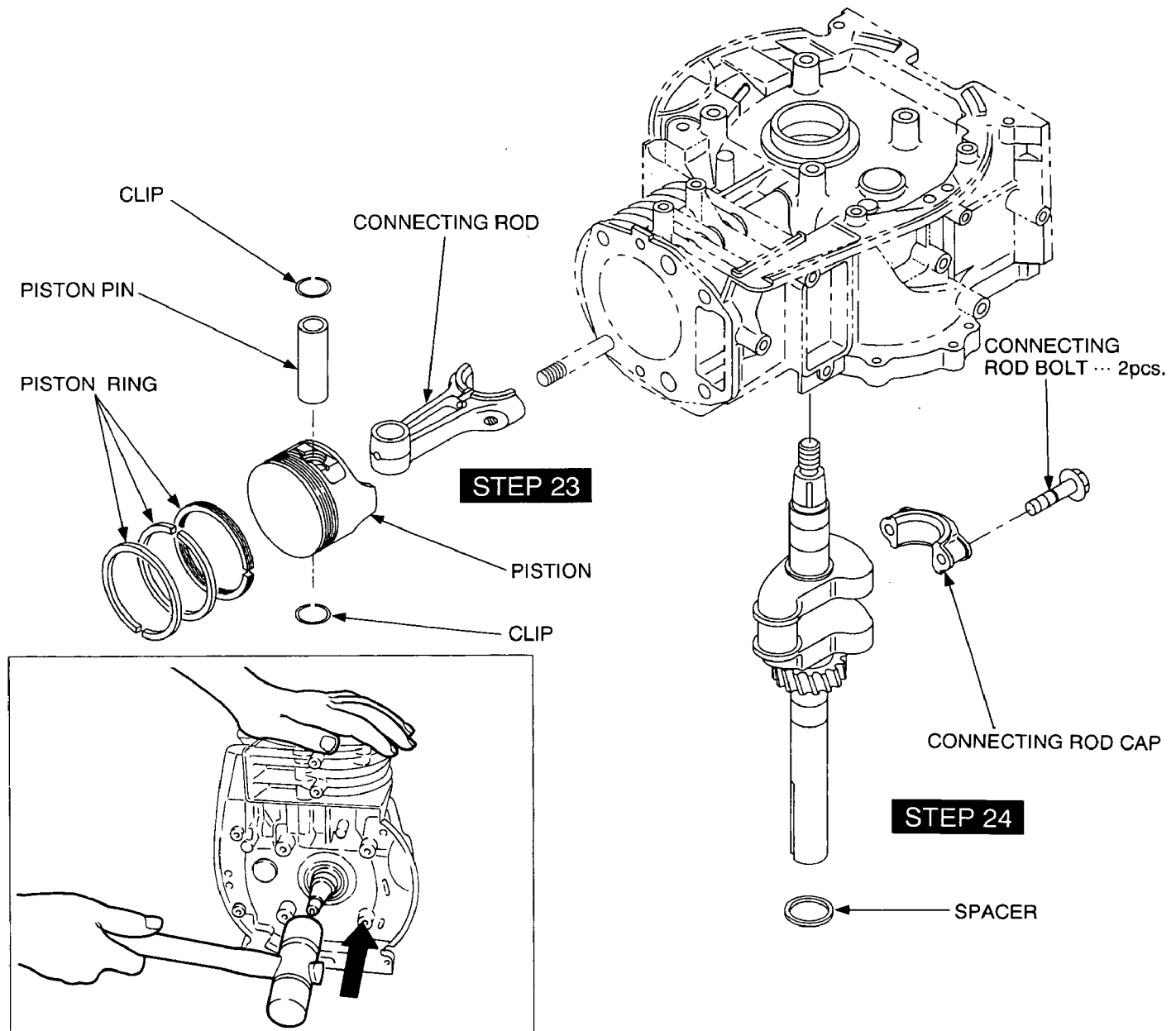

Fig. 5-22

Fig. 5-23

5-4 REASSEMBLY PROCEDURES

● PRECAUTIONS FOR REASSEMBLY

- 1) Clean parts thoroughly before reassembly.
Pay utmost attention to cleanliness of piston, cylinder, crankshaft, connecting rod and bearings.
- 2) Scrape off all carbon deposits from cylinder head, piston top and piston ring grooves.
- 3) Check lip of oil seals. Replace oil seal if the lip is damaged.
Apply oil to the lip before reassembly.
- 4) Replace all the gaskets with new ones.
- 5) Replace keys, pins, bolts, nuts, etc., if necessary.
- 6) Torque bolts and nuts to specification referring to page 59 "12-2 TORQUE SPECIFICATIONS".
- 7) Apply oil to rotating and sliding portions.
- 8) Check and adjust clearances and end plays where specified in this manual.

5-4-1 CRANKSHAFT

- (1) Install crankshaft on crankcase using an oil seal guide to avoid damage to crankshaft oil seal. (See Fig. 5-24.)

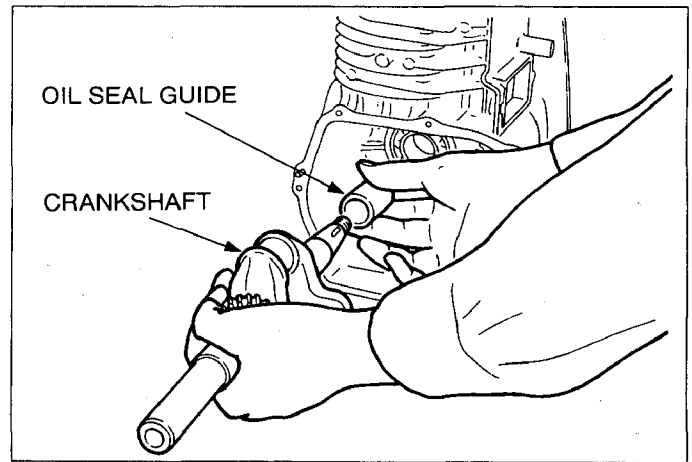

Fig. 5-24

5-4-2 PISTON AND PISTON RINGS

(1) Install oil ring first, then second ring and top ring. Spread ring only far enough to slip over piston and into correct groove. Use care not to distort ring. (See Fig. 5-26.)

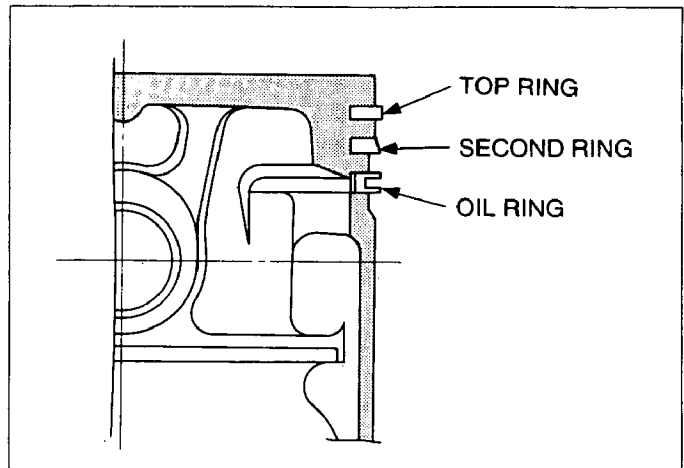

Fig. 5-25

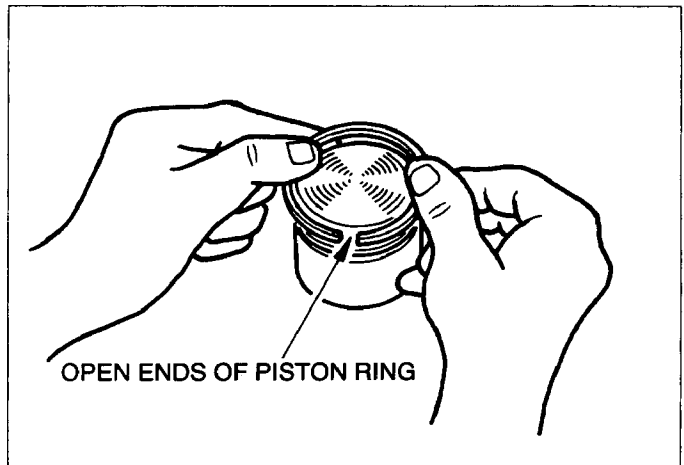

Fig. 5-26

5-4-3 PISTON AND CONNECTING ROD

Install piston on connection rod.

Oil the small end of connecting rod before installing piston and piston pin.

Use clips on both side of the piston pin to secure piston pin in position.

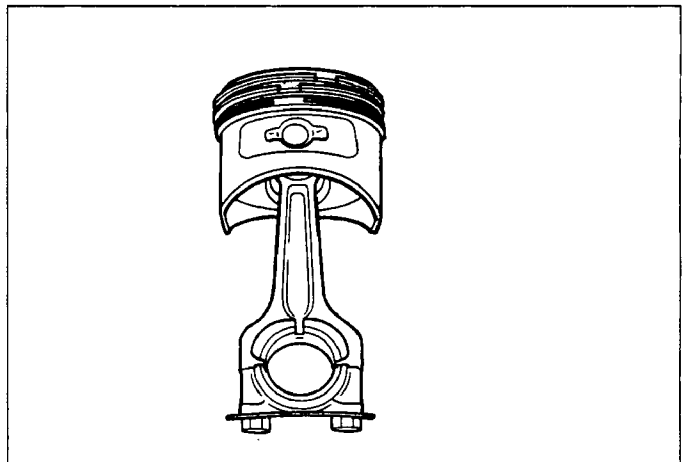

Fig. 5-27

5-4-4 CONNECTING ROD

- (1) Before installing the piston and connecting rod in the cylinder, oil the piston, piston rings and cylinder wall.
- (2) Stagger the piston ring gaps 90° apart around the piston. (See Fig. 5-28.)
Use a piston ring compressor when installing piston.
Install piston and rod with the "MA" marks on flywheel side of the crankcase.
(See Fig. 29.)
- (3) Turn crankshaft to bottom dead center, then tap lightly top of the piston until large end of the connecting rod meets crank pin.

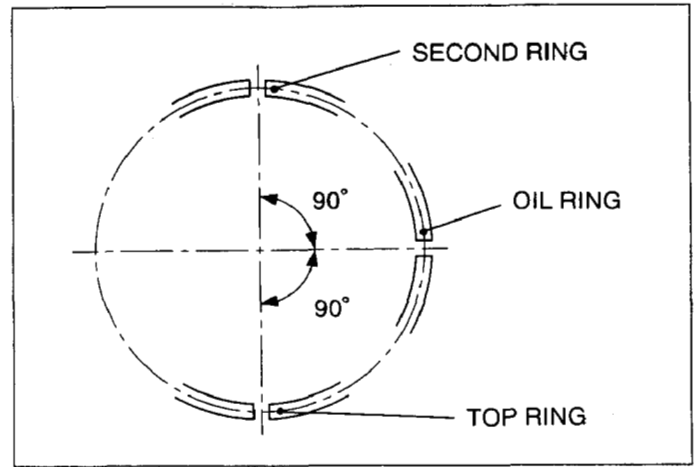

Fig. 5-28

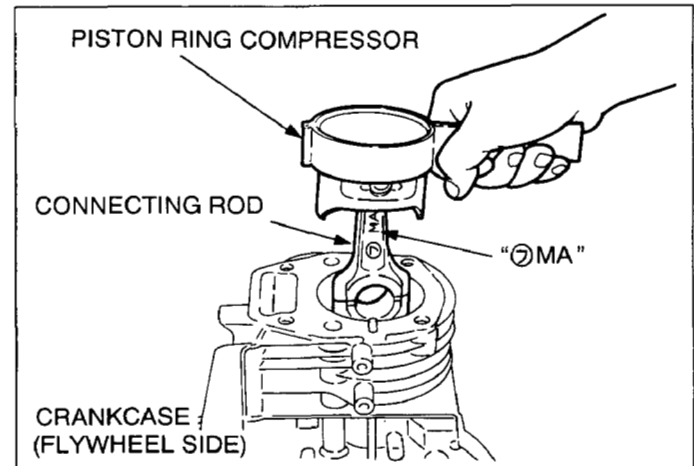

Fig. 5-29

- (4) Install connecting rod cap with the match mark on the main bearing cover side. (Match this mark with the one on the left side of connecting rod's large end viewed from main bearing cover side.) (See Fig. 30)

Connecting rod bolt 2 pcs.

Tightening torque
17~20 N·m
170~200 kg·cm
12.2~14.5 ft·lb

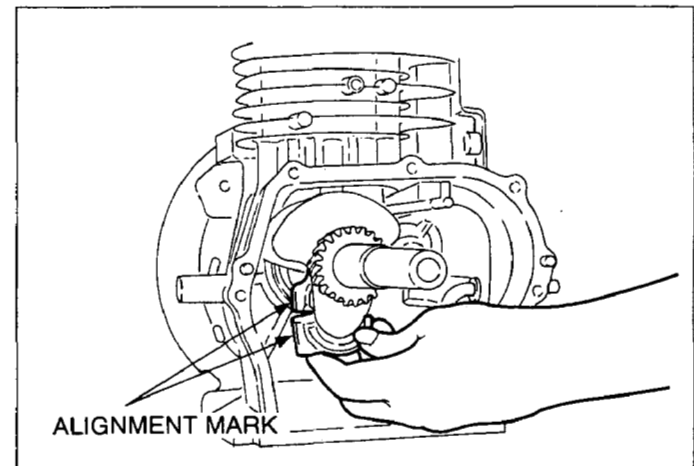

Fig. 5-30

[NOTE]

Check for free movement of connecting rod by turning crankshaft slowly.

5-4-5 TAPPET AND CAMSHAFT

- (1) Oil tappets and install in their original position.
Push in fully to avoid damage during camshaft installation.
- (2) Lubricate bearing surfaces of camshaft.
Align timing mark on crankshaft gear with timing mark on camshaft and install camshaft in the crankcase. (See Fig. 5-31.)

CAUTION

Incorrect valve timing will cause engine's malfunction.

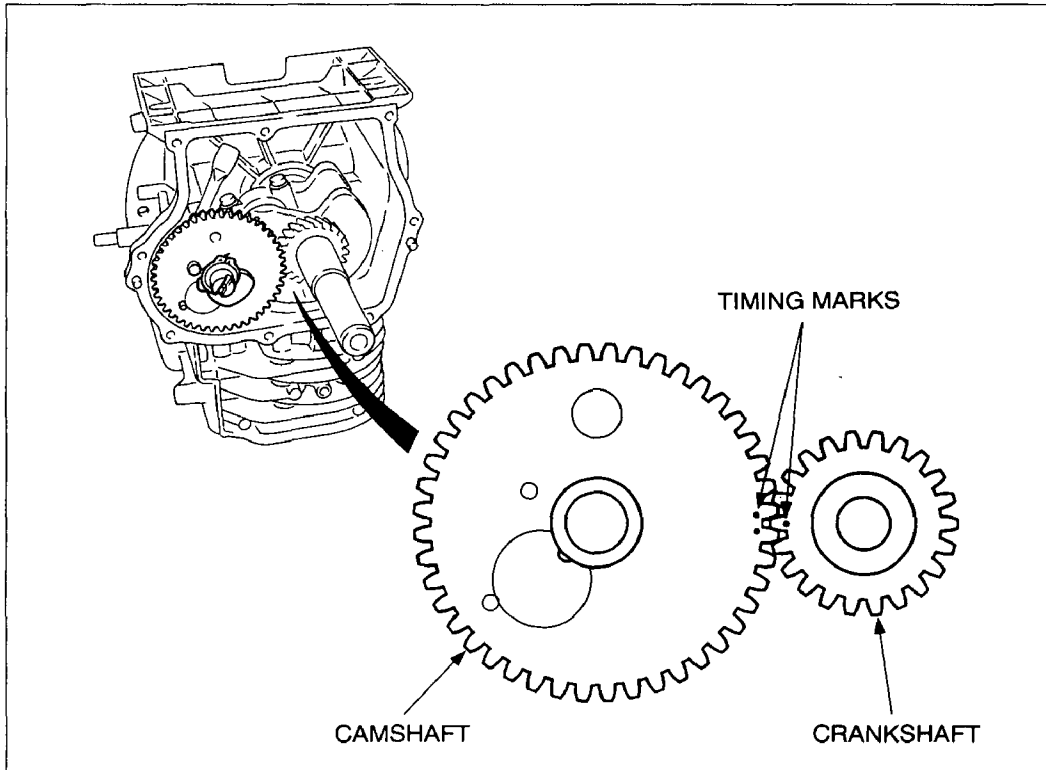

Fig. 5-31

5-4-6 ADJUST CRANKSHAFT END PLAY

- (1) Adjust end play to the specified values using the proper spacer.
The proper spacer may be determined by the following manner.

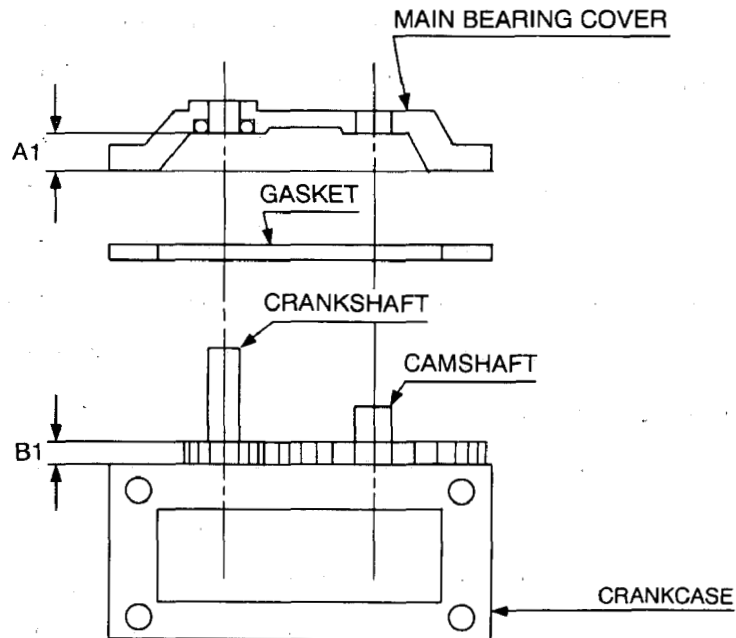

Fig. 5-32

● CRANKSHAFT END PLAY

- (1) Measure the depth "A1" (From the mating surface to the inner race of the ball bearing.)
 (2) Measure the height "B1" (From the mating to the crank gear.)
 $(A1+0.3) - B1 = \text{SIDE CLEARANCE (mm)}$
 $(\text{SIDE CLEARANCE}) - 0.2 = \text{THICKNESS OF CRANKSHAFT SHIM (mm)}$
 $(A+0.012) - B1 = \text{SIDE CLEARANCE (in)}$
 $\text{SIDE CLEARANCE} - 0.008 = \text{THICKNESS OF CRANKSHAFT SHIM (in)}$

Following are available spacer shims.

	CRANKSHAFT
SPACER SHIMS	$T=0.6 \text{ mm (0.024")}$ $T=0.8 \text{ mm (0.031")}$ $T=1.0 \text{ mm (0.039")}$

5-4-7 MAIN BEARING COVER

- (1) Install oil pump to the main bearing cover.
M6 × 12 mm bolt 4 pcs.

Tightening torque
8~9.5 N·m
80~100 kg·cm
6~7 ft·lb

- (2) Lubricate the oil seal and bearing surfaces. Add a light film of oil on the main bearing cover face to hold the gasket in place.
Place spacers chosen at procedure 5-4-6 on crankshaft.
Use an oil seal guide when installing the main bearing cover to avoid damaging the seal.
Tap the cover into place with a soft hammer.
Main bearing cover.
M6 × 30 mm bolt and washer 8 pcs.

Tightening torque
8~9.5 N·m
80~100 kg·cm
6~7 ft·lb

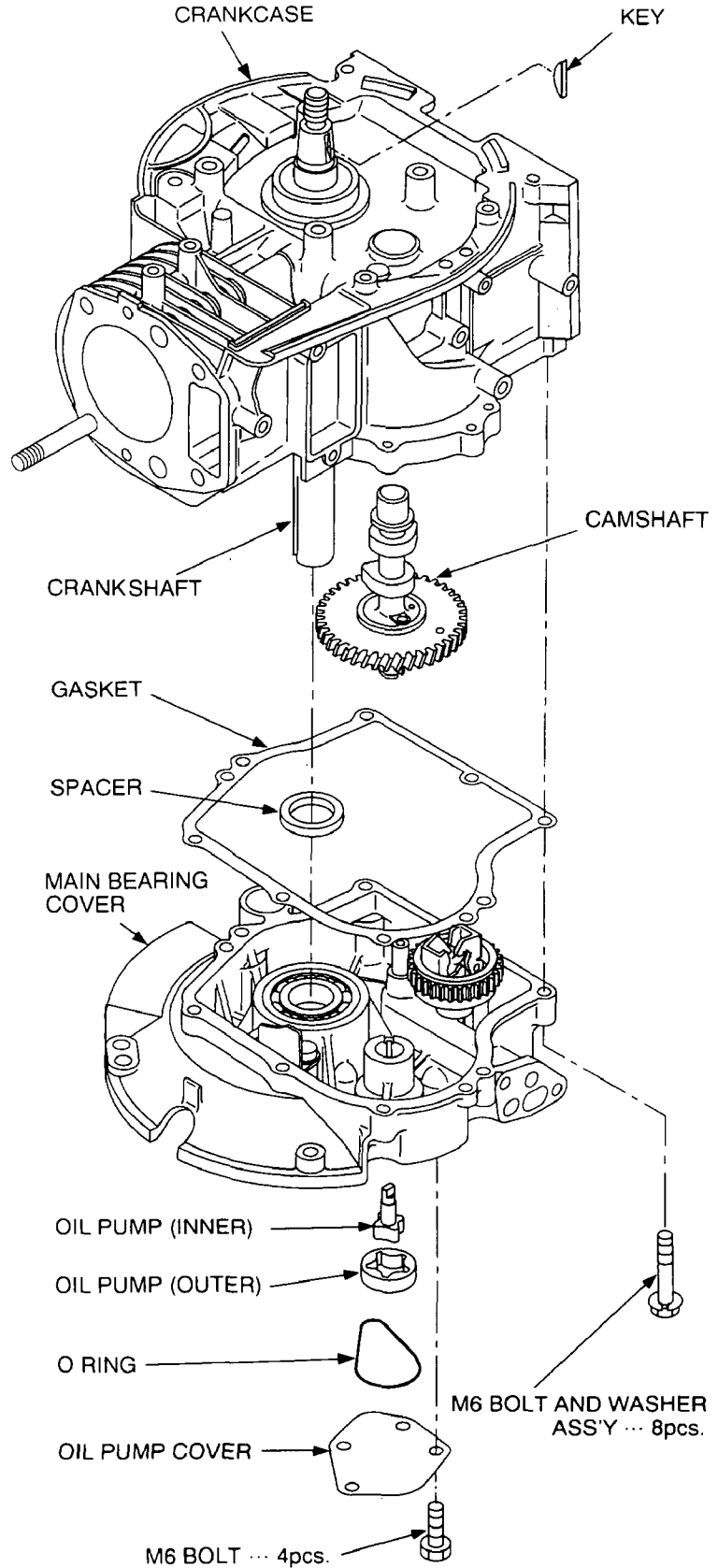

Fig. 5-33

5-4-8 BREATHER VALVE

Attach breather plate (breather valve) and breather cover to crankcase using proper gaskets.

(See Fig. 5-34.)

Replace gaskets with new ones if they are torn or damaged.

Replace breather hose at least once a year or when ever a crack was found.

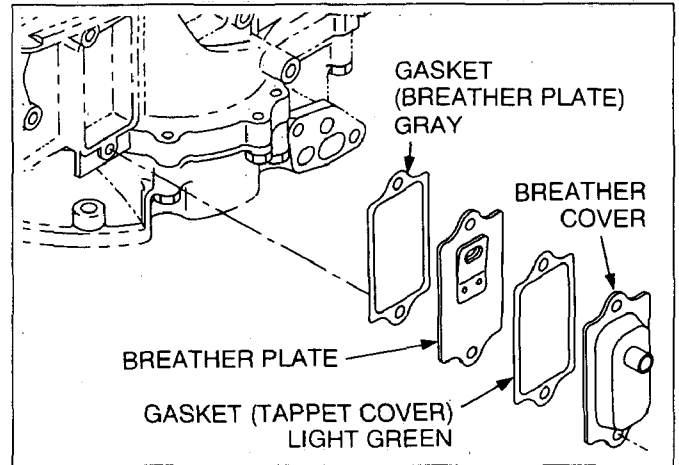

Fig. 5-34

5-4-9 CYLINDER HEAD

(1) Clean carbon and gum deposits from the valves, seats, ports and guides. Inspect the valves, valve seats and valve guides.

(2) Replace valves that are badly burned, pitted or warped.

(3) When installing the valves in the cylinder head, oil the valve stems and insert them into the valve guide. Then place the cylinder head on a flat table, install the washer, valve spring and spring retainer. (See Fig. 5-35.)

(4) Valve guides should be replaced when the valve stem clearance exceeds specifications (See "SERVICE DATA" page 57)

Draw the valve guides out and press the new guides in.

Refer to "SERVICE DATA" for clearance specifications.

After replacing the valves and guides, lap valves in place until a uniform ring shows around the face of the valve. Clean valves and wash cylinder head thoroughly.

(5) Install cylinder head to cylinder with new head gasket.

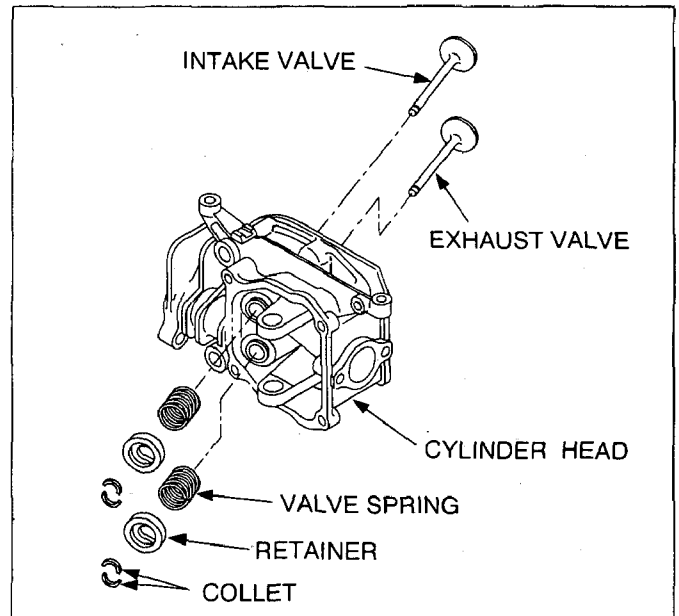

Fig. 5-35

[NOTE]

When installing head gasket, show Fig. 5-36.

Tighten three flange bolts and a flange nut evenly in three steps by the following tightening torque:

Cylinder head M8 × 65 mm bolt 2 pcs.
 M8 × 40 mm bolt 1 pce.
 M8 flange nut 1 pce.

Tightening torque		
1st step	2nd step	final step
5 N·m	10 N·m	23-26 N·m
50 kg·cm	100 kg·cm	230-270 kg·cm
3.6 ft·lb	7.2 ft·lb	17-30 ft·lb

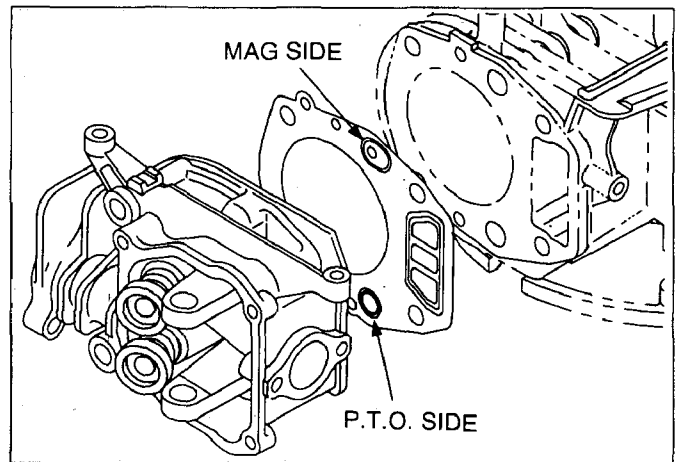

Fig. 5-36

5-4-10 ROCKER ARMS AND PUSH RODS

- (1) Insert push rods into crankcase.
Put push rod tip in the hollow of tappet top.
- (2) Apply oil to the rocker arms and assemble them to the cylinder head using the rocker shaft and spacer.

5-4-11 VALVE CLEARANCE ADJUSTMENT

- (1) Position the piston at the top dead center of the compression stroke. The top dead center may be obtained by placing the key slot on the power take off shaft to 45° from the center of cylinder.

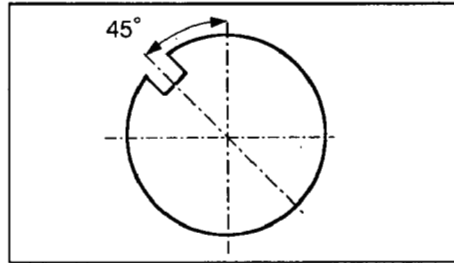

Fig. 5-37

- (2) Loosen the lock nut on the rocker arm and turn the adjusting screw to adjust the clearance between the rocker arm and the valve stem end. (See Fig. 5-38.)
Tighten the lock nut.

Valve clearance
0.085-0.115 mm
0.0034-0.0045 in.

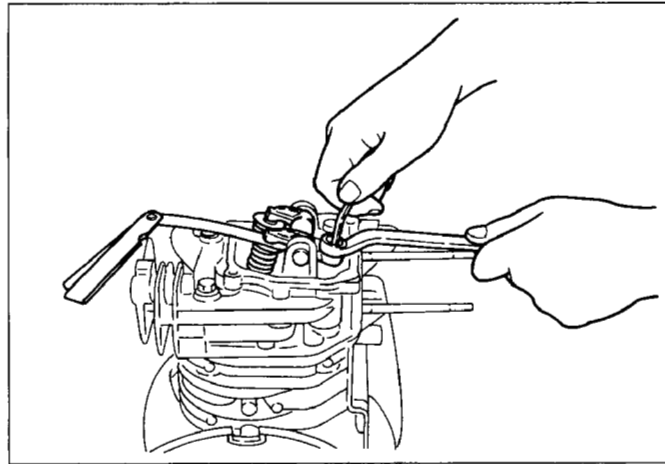

Fig. 5-38

[NOTE]

Check and adjust valve clearance with engine cold.
Check operation of valves by turning crankshaft .
Remeasure valve clearance.

- (3) Install guide plate and rocker cover using a gasket.
M6 × 12 mm bolt ···· 4 pcs.

5-4-12 BRAKE ASSEMBLY

Install brake assy to the engine.

M6 × 12 mm bolt ···· 4 pcs.

Tightening torque
8~9.5 N·m
80~100 kg·cm
6~7 ft·lb

Never apply oil or (grease) on the internal of flywheel and brake.

5-4-13 FLYWHEEL MAGNETO

- (1) Put the woodruff key in the key way of crankshaft.

Wipe off oil and de-grease thoroughly from the tapered portion of the crankshaft and the flywheel center hole.

- (2) Pull the brake lever.
(3) Install the flywheel to crankshaft.
Tighten the flywheel nut with the starter pulley. (See Fig. 5-39.)

Tightening torque
59~63 N·m
600~650 kg·cm
43~47 ft·lb

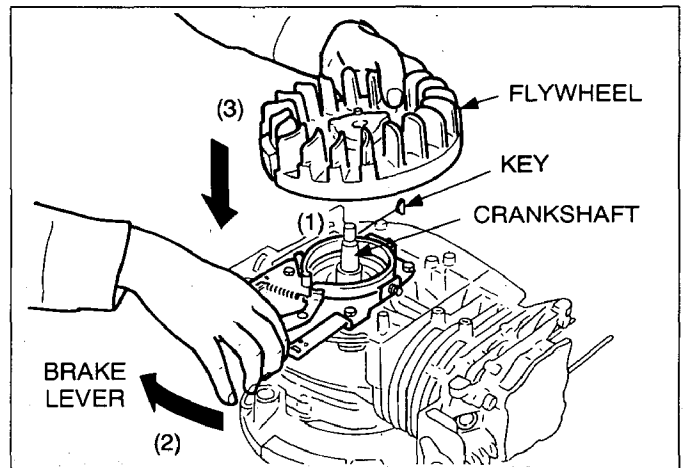

Fig. 5-39

5-4-14 IGNITION COIL

Install the ignition coil to the crankcase.

Adjust the air gap between the ignition coil and the flywheel using a thickness gauge (filler gauge) and tighten the bolts. (See Fig. 5-40.)

M6 × 30 mm bolt ···· 2 pcs.

Air gap
0.3~0.5 mm
0.012~0.020 in.

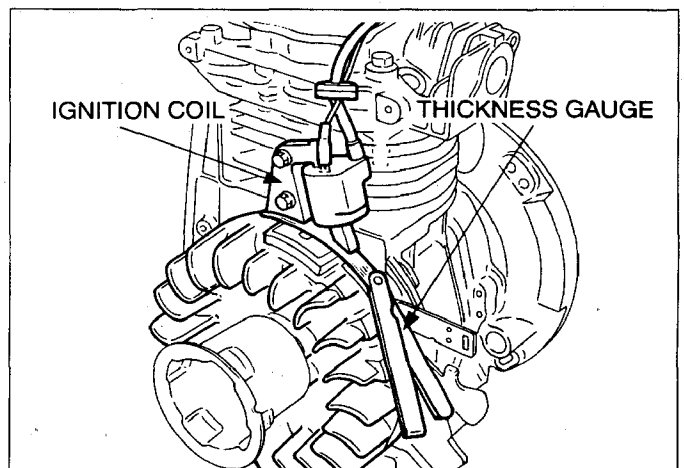

Fig. 5-40

5-4-15 BLOWER HOUSING AND BRACKETS

Install blower housing, oil filler bracket (fuel tank) and air cleaner bracket.

Classic Steel

M6 × 12 mm bolt 1 pce.

M6 × 14 mm bolt 3 pcs.

Pro Poly

M6 × 12 mm bolt 2 pcs.

M6 × 14 mm bolt 2 pcs.

5-4-16 CYLINDER BAFFLE

Install cylinder baffle.

M6 × 8 mm bolt 1 pce.

5-4-17 OIL FILLER

Install oil filler to the engine.

M6 × 12 mm bolt 1 pce.

5-4-18 CARBURETOR

Install the gaskets, insulator and carburetor.

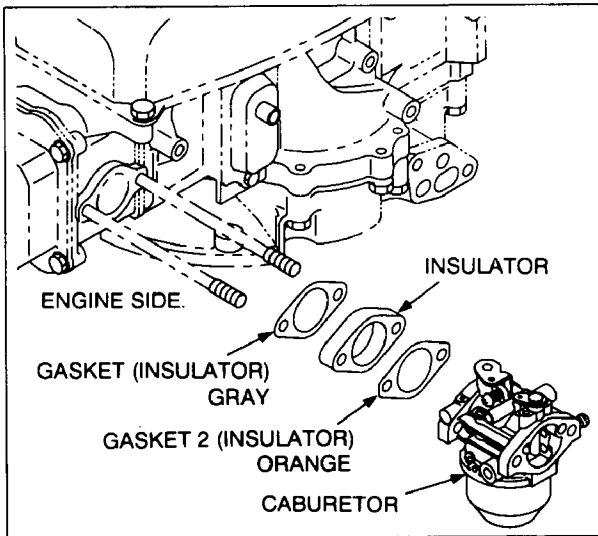

Fig. 5-42

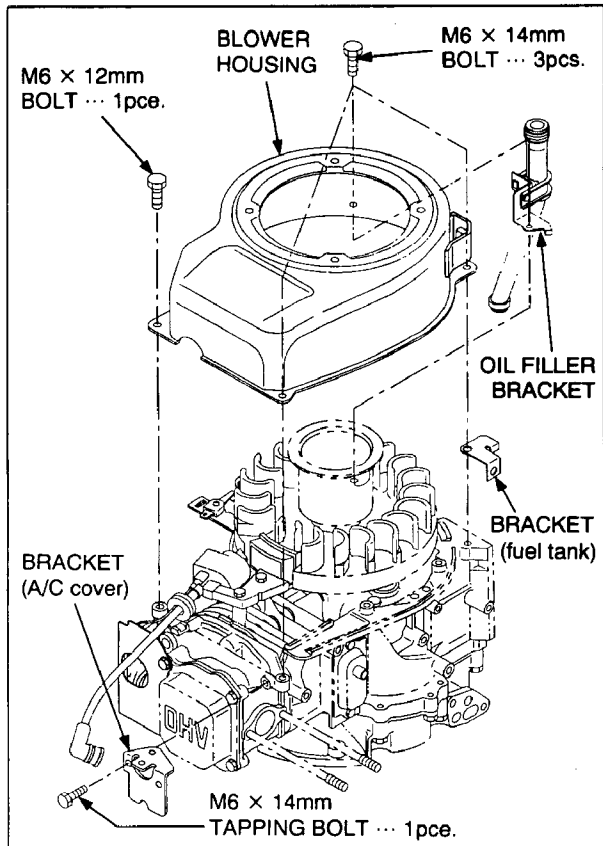

Fig. 5-41 (Classic Steel)

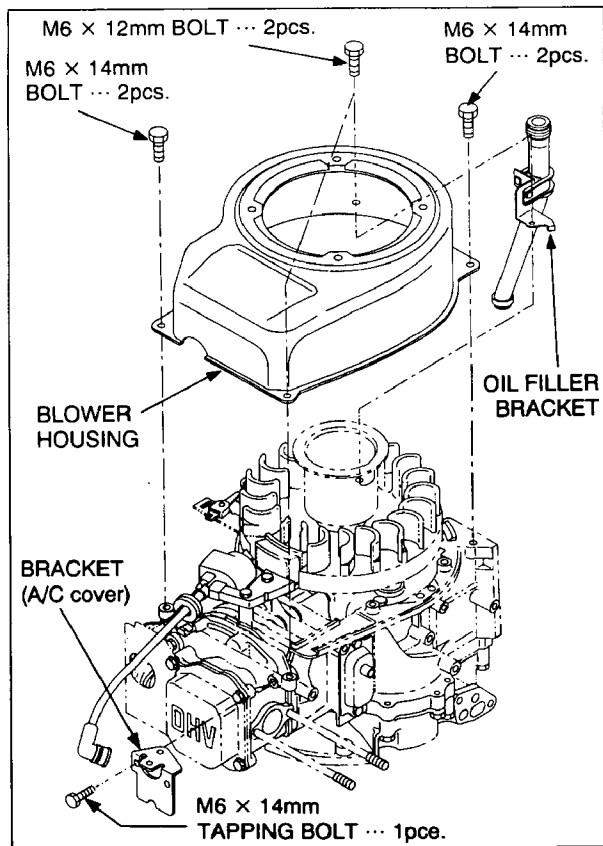

Fig. 5-41 (Pro Poly)

5-4-19 AIR CLEANER

(1) Install cleaner base on studs, install bracket, cleaner.

Tighten the clamp for stop switch wire together with cleaner bracket on crankcase side.

M6 Nut 2pcs.

Tightening torque
8-9.5 N·m
80-100 kg·cm
6-7 ft·lb

[NOTE]

Attach the air cleaner gasket to the carburetor flange when installing air cleaner base on the engine. (See Fig. 5-43.)

(2) Install cover and element to the air cleaner base.

M6 wing bolt 1pce.

(3) Connect a breather pipe between breather and air cleaner.

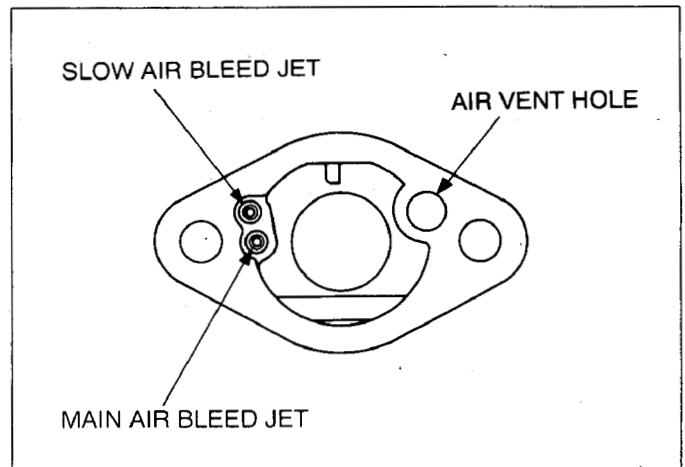

Fig. 5-43

5-4-20 GOVERNOR ADJUSTMENT

For correct carburetor throttle opening and governor regulation, the governor lever must be properly adjusted.

(1) Install throttle lever control linkage on governor lever and choke shaft control rod in choke lever.

(2) Hook spring from control lever hole (A) to the hole (B) in governor lever as shown in Fig. 5-44. Install bracket assembly on crankcase.

(3) Install governor lever on governor shaft but do not tighten clamp screw.

(4) Turn governor lever clockwise until throttle valve in carburetor is opened fully. Hold lever in this position. (See Fig. 5-45.)

[NOTE]

Check that governor lever clamp screw is loose so governor shaft can be turned independently of lever.

(5) Insert a screwdriver in slot at end of governor shaft. Turn clockwise as far as shaft can be turned. Tighten governor lever clamp screw.

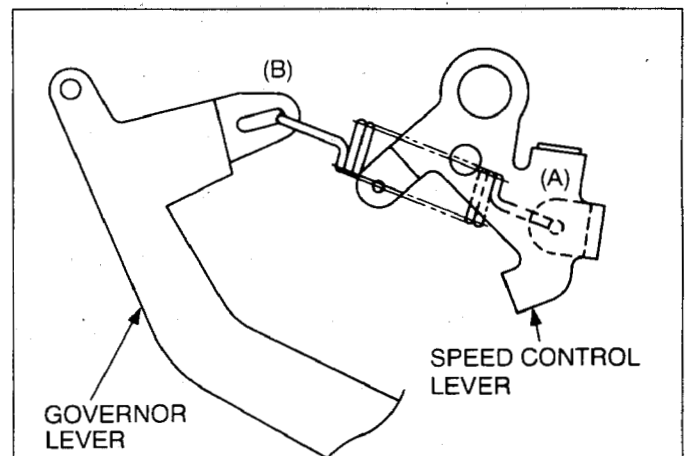

Fig. 5-44

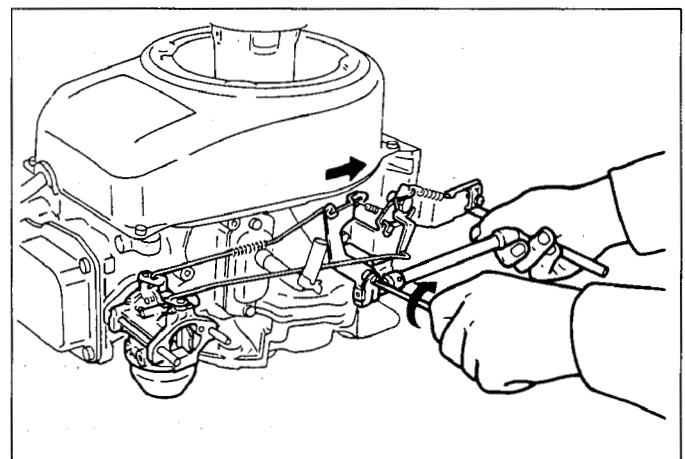

Fig. 5-45

5-4-21 MUFFLER AND MUFFLER COVER

- (1) Install muffler and muffler gasket.

M8 × 70 mm bolt and washer assy 2pcs.

M8 × 16 mm bolt and washer assy 1pce.

Tightening torque
22.5~26.5 N·m
230~270 kg·cm
16.6~19.5 ft·lb

- (2) Install muffler cover to the muffler.

M5 × 10 mm Tapping screw 3 pcs.

5-4-22 FUEL TANK (if applicable)

- (1) Install fuel tank bracket.

M6 × 12 mm bolt 2pcs.

- (2) Install fuel tank.

M6 × 12 mm bolt 2pcs.

- (3) Install side guard.

M6 × 12 mm bolt 2pcs.

- (4) Install cover (stop switch).

5-4-23 RECOIL STARTER AND ENGINE SHROUD

- (1) Install recoil starter and engine shroud.

M6 × 8 mm bolt 4pcs.

- (2) Connect fuel pipe between fuel cock and carburetor.

5-4-24 OIL FILTER BRACKET AND OIL FILTER

- (1) Install oil filter bracket

M6 × 12 mm bolt 2pcs.

Tightening torque
8~9.5 N·m
80~100 kg·cm
6~7 ft·lb

- (2) Tighten filter using a proper tool about 3/4 turn after gasket contacts mounting surface of engine.

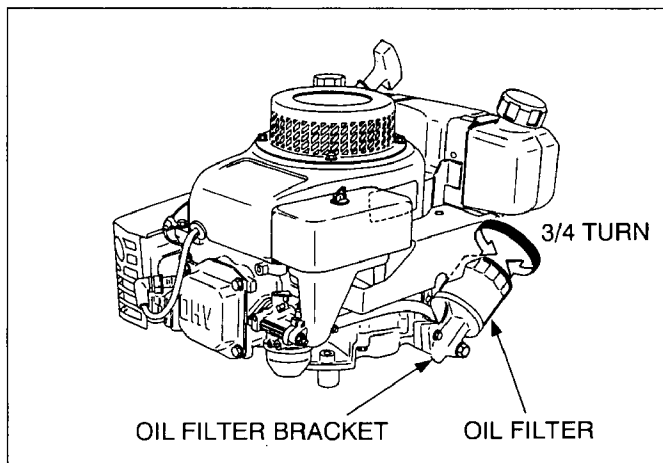

Fig. 5-46

[NOTE]

Check for leaks at test running after engine assembly is completed.

5-4-25 SPARK PLUG

(1) Install spark plug to the cylinder head.

Spark plug : CHAMPION L86C

Tightening torque	
New spark plug	Retightening
11.8~14.7 N·m	22.6~26.5 N·m
120~150 kg·cm	230~270 kg·cm
8.7~10.9 ft·lb	16.6~19.5 ft·lb

(2) Connect spark plug cap to the spark plug.

5-4-26 ENGINE OIL

After complete reassembly, turn the engine over and pull the recoil starter to check for any abnormal conditions or loose fitting parts.

Review and check wiring.

Fill crankcase with correct grade of oil. (See page 59, "OIL GRADE CHART")

Crankcase oil capacity : 500cc

5-4-27 CHOKE AND SPEED ADJUSTMENT

(1) Start the engine. (Operate the engine without load.)

(2) In order to fix the position of the speed control lever, insert a philips screw driver into the hole (A) of the speed control lever through the hole of the speed control bracket.

(3) Loosen the adjusting screw on the speed control lever.

(4) Check the engine speed by a tachometer or a revolution counter.

Correct engine speed is 3350 r.p.m.

(5) Loosen the bolts (B) and (C), Move the speed control bracket to the position where the engine speed become 3350 r.p.m.

In order to reduce the engine speed move the speed control bracket to the left.

(6) After adjusting the engine speed, re-tighten the two bolts (B) and (C) to fix the bracket.

(7) Tighten the adjusting screw until it contacts the choke lever.

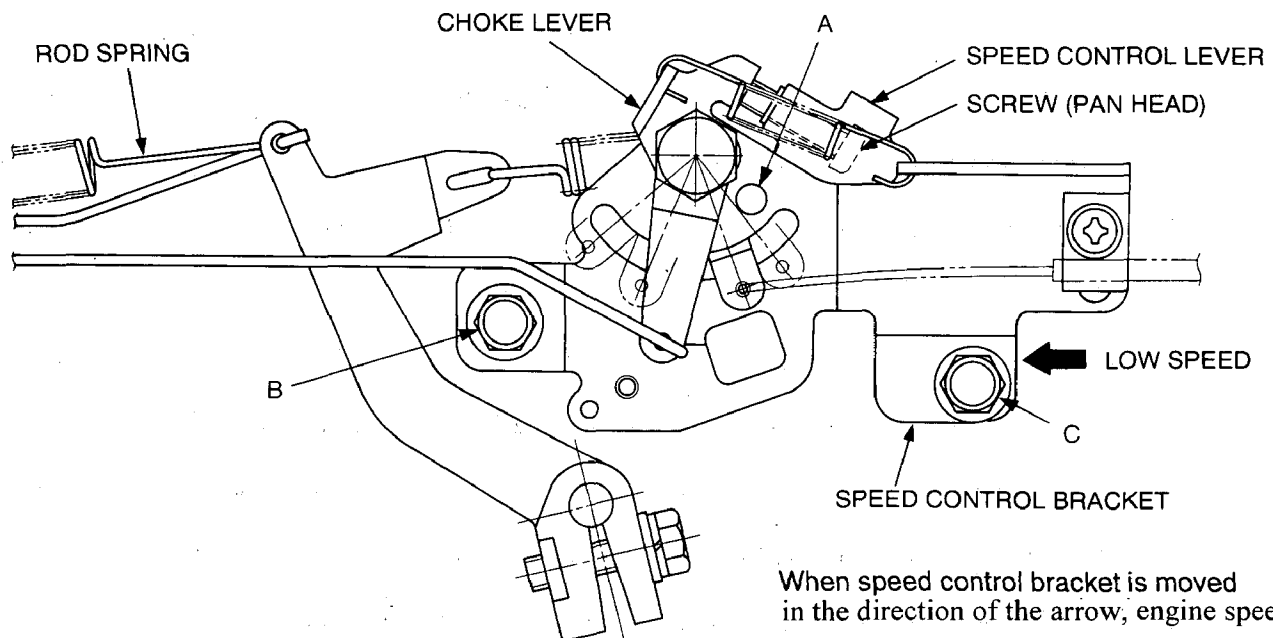

When speed control bracket is moved in the direction of the arrow, engine speed is reduced.

Fig. 5-47

5-5 BREAK-IN OPERATION

An engine that has been completely overhauled by being fitted with a new piston, rings, valves and connecting rod should be thoroughly RUN- IN before being put back into service.

Good bearing surfaces and running clearances between the various parts can only be established by operating the engine under reduced speed and loads for a short period of time.

While the engine is being tested, check for oil leaks.

Make final carburetor adjustment and regulate the engine operating speed.

Steps	Load	Engine speed	Time
Step 1	No load	2500 rpm	10 min
Step 2	No load	3000 rpm	10 min
Step 3	2.0HP	3000 rpm	30 min
Step 4	4.0HP	3000 rpm	60 min

6. MAGNETO

6-1 FLYWHEEL MAGNETO

The ignition system of the EH18V is a pointless flywheel magneto with an automatic advancing characteristic.

Being different from the breaker point type ignition system, this system is completely free from such troubles as starting-up failure due to dirty, burnt or corroded point surface. The electronic automatic advancing ensures extremely easy starts and stable high performance at operating speed by advancing the ignition timing to the most suitable point.

6-2 BASIC THEORY

To ensure the easy startability of the engine, the step advancing ignition timing system is incorporated in the ignition coil. This system enables the engine to have basically two different ignition timings according to the engine speed. Following are the explanation how the system works.

1) At lower speed of the engine

Rotation of the flywheel induces current I_1 , as this current flows through the base terminal of the power transistor, it is activated and the current I_2 starts flowing.

As the engine reaches the ignition timing, the ignition timing control circuit for the lower engine speed is activated and lets the current I_3 flow through the base terminal of the power transistor.

This generates the collector current I_4 which will bypass the current I_1 and abruptly shut off the current I_2 because the power transistor is turned off.

This sudden current change generates a big voltage on the secondary side of the ignition coil and which sparks the spark plug.

2) At the higher engine speed

Rotation of the flywheel generates the current I_1 as this current flows through the base terminal of the power transistor, it is activated and the current I_2 starts flowing.

As the engine reaches the ignition timing, the ignition timing control circuit for the higher engine speed is activated and provides the base current I_5 to the power transistor. This current induces the collector current I_6 and will bypass the current I_1 to shut down the current I_2 abruptly because the power transistor is turned off.

This sudden current change generates a big voltage on the secondary side of the ignition coil causing sparks at the spark plug.

The ignition timing control circuit for the higher engine speed is activated sooner than the control circuit for the lower speed and not activated when the engine speed is in a lower range.

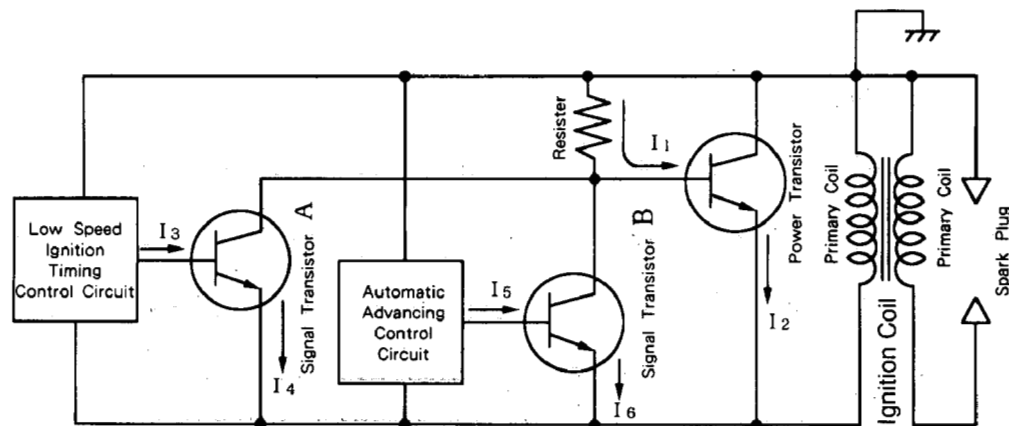

Fig. 6-1

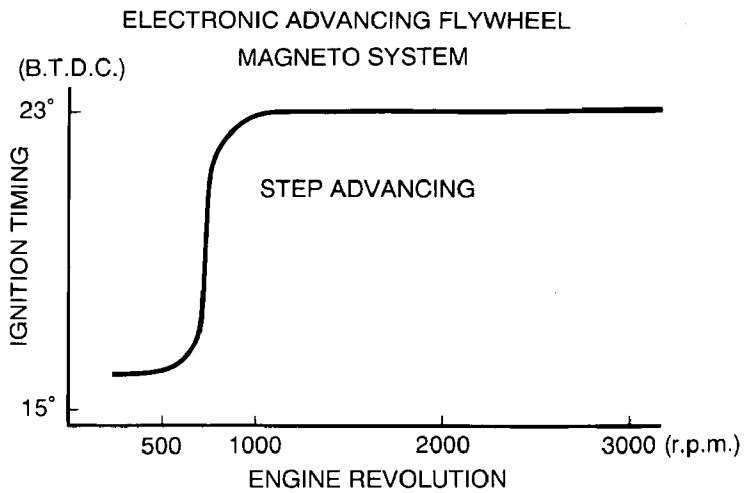

Fig. 6-2

6-3 WIRING DIAGRAM

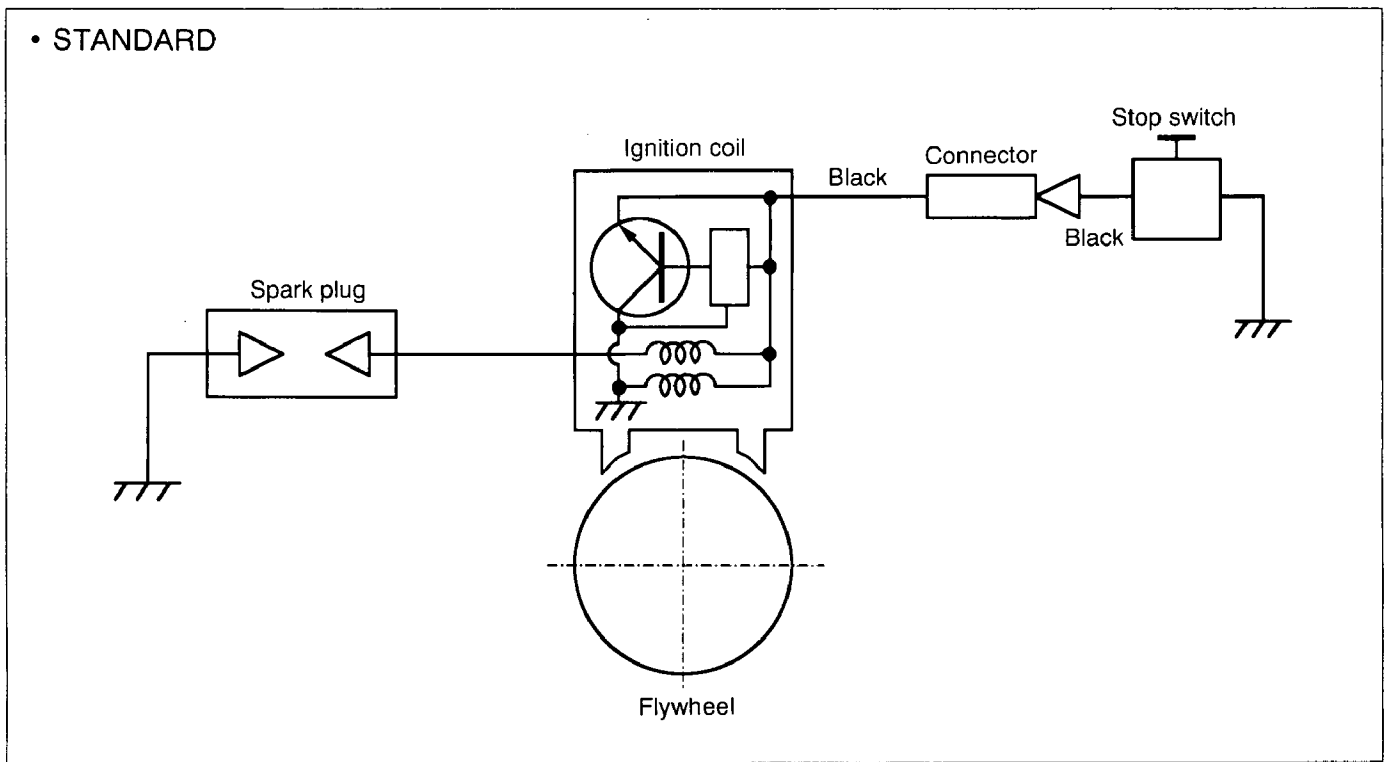

Fig. 6-3

7. AUTOMATIC DECOMPRESSION SYSTEM

The decompression system operates to release compression by lifting up the exhaust valve at starting. The release lever mounted on the camshaft has a flyweight at one end and a crescent cam at the other end. When starting the engine, the crescent cam juts out from the exhaust cam. The exhaust tappet rides over the crescent cam opening the exhaust valve to release compression. The exhaust tappet rides over the crescent cam opening the exhaust valve to release compression.

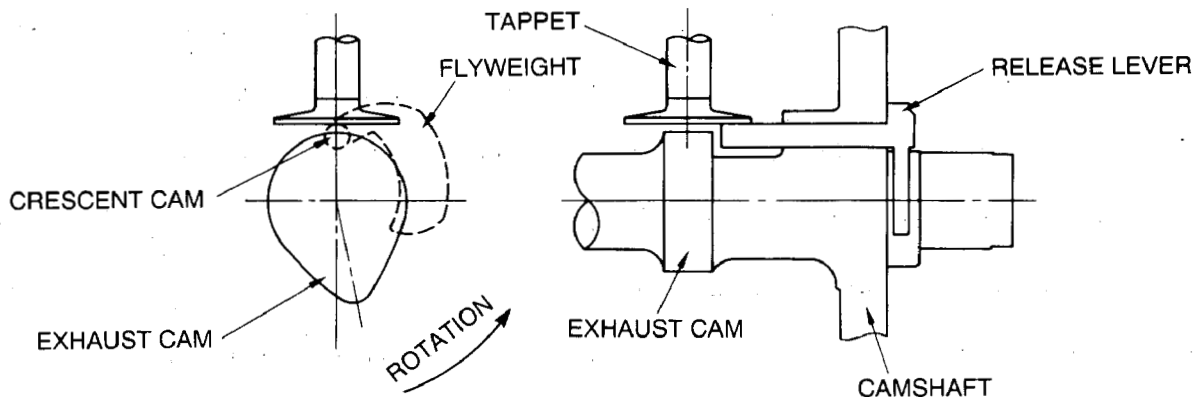

Fig. 7-1

When the crank speed reaches a certain revolution, the flyweight of the release lever moves outward by the centrifugal force turning the release lever to retract below the crescent cam. Thus the exhaust valve closes allowing a sufficient compression for the engine to start up.

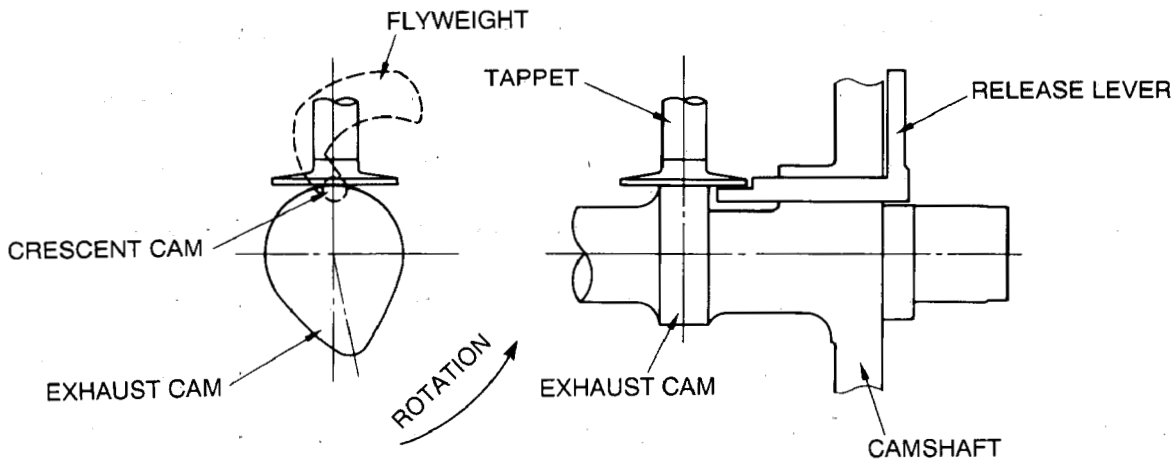

Fig. 7-2

8. CARBURETOR

8-1 OPERATION AND CONSTRUCTION (See Fig. 7-2. and 8-1.)

8-1-1 FLOAT SYSTEM

The float chamber is located just below the carburetor body and, with a float and a needle valve, maintains a constant fuel level during engine operation.

The fuel flows from the fuel tank into the float chamber through needle valve. When the fuel rises to a specific level, the float rises ; and when its buoyancy and fuel pressure are balanced, the needle valve closes to shut off the fuel, thereby keeping the fuel at the predetermined level.

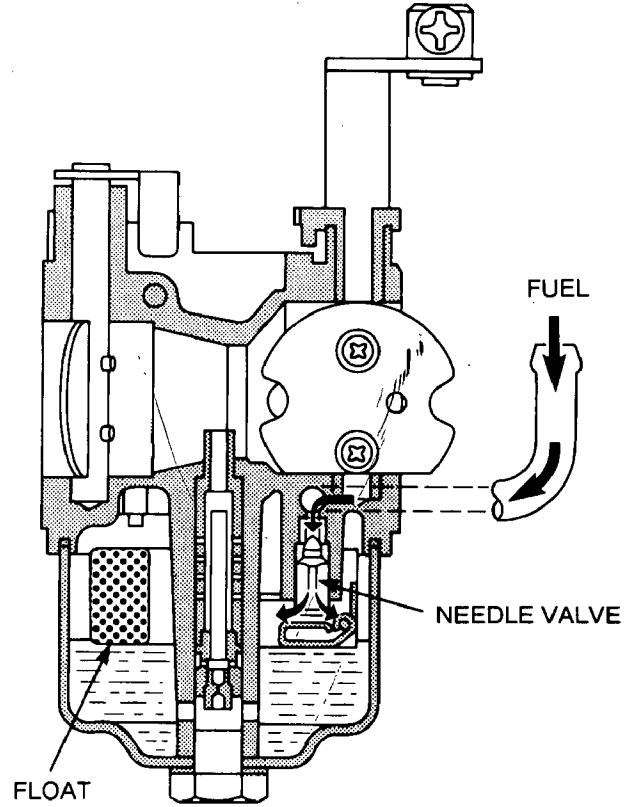

Fig. 8-1

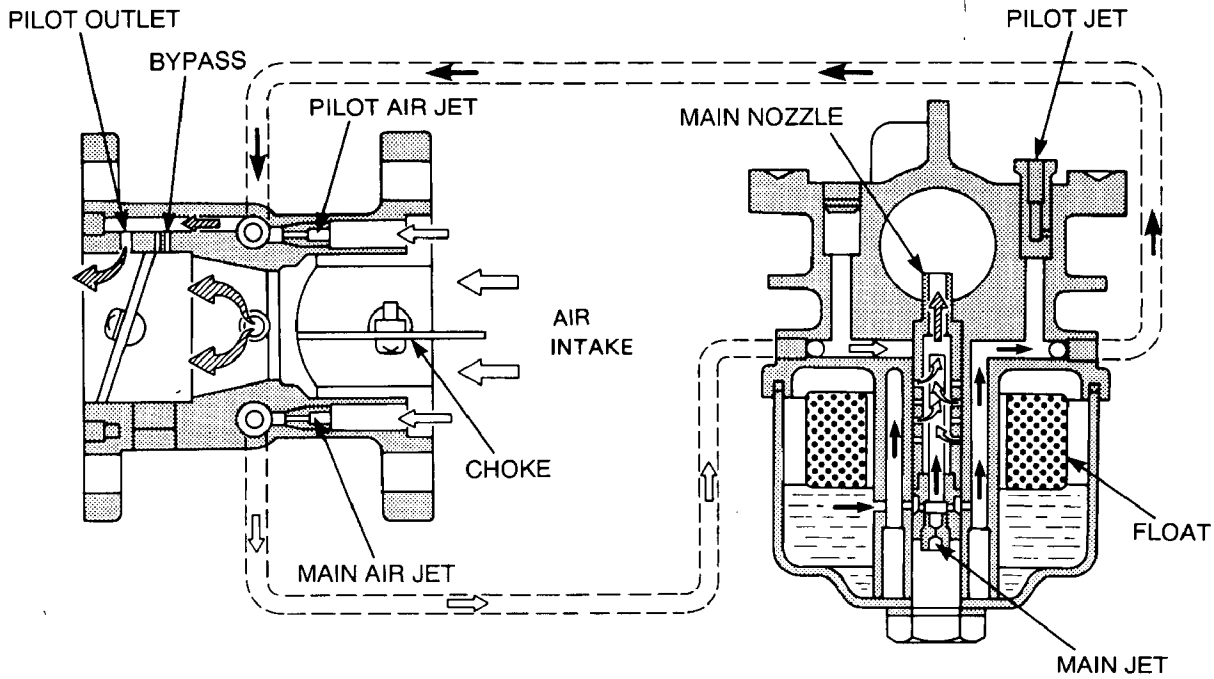

Fig. 8-2

8-1-2 PILOT SYSTEM

The pilot system feeds the fuel to the engine during idling and low-speed operation.

The fuel is fed through the main jet to the pilot jet, where it is metered, and mixed with the air metered by the pilot air jet.

The fuel-air mixture is fed to the engine through the pilot outlet and the bypass.

At idling speed, the fuel is mainly fed from the pilot outlet.

8-1-3 MAIN SYSTEM

The main system feeds the fuel to the engine at medium- and high-speed operation.

The fuel is metered by the main jet and fed to the main nozzle. The air metered by the main air jet is mixed with the fuel through the bleed holes in the main nozzle, and the mixture is atomized out of the main bore. It is mixed again with the air taken through the air cleaner into an optimum fuel-air mixture, which is supplied to the engine.

8-1-4 CHOKE

The choke is used for easy start when engine is cold. When the starter is operated with a closed choke, the negative pressure applied to the main nozzle increases and draws much fuel accordingly; thus easily start up the engine.

8-2 DISASSEMBLY AND REASSEMBLY

Apart from mechanical failures, most of carburetor troubles are caused by an incorrect mixing ratio, which may arise mainly due to a clogged up air or fuel passage in jets, or fuel level variations. In order to assure proper flow of air and fuel, the carburetor must be kept clean at all times. The carburetor disassembly and reassembly procedures are as follows : (See Fig. 8-2.)

8-2-1 THROTTLE SYSTEM

(1) Remove the philips screw (15) and throttle valve (14), and pull out the throttle shaft(13).

(2) The spring (19) can be taken out by removing the throttle stop screw (20).

* Exercise care not to damage throttle valve ends.

8-2-2 CHOKE SYSTEM

(1) Remove the clip (23) and choke valve (17), and pull out the choke shaft (16).

(2) When reassembling the choke shaft, make sure that the cutout in the choke valve faces the main air jet.

8-2-3 PILOT SYSTEM

(1) Remove the pilot jet (18), using correct tool to avoid damage to it.

(2) Reassembly

Tighten the pilot jet securely. Otherwise, the fuel may leak, causing engine malfunction.

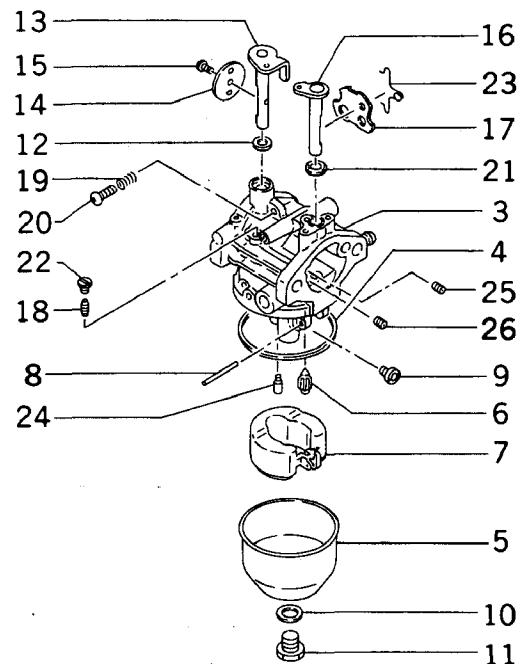

Fig. 8-3

8-2-4 MAIN SYSTEM

(1) Remove the bolt (11) and take out float chamber body (5).

(2) From the body (3) remove the main jet (9).

(3) Reassembly

a) Fasten the main jet securely to the body. Otherwise, the fuel may become too rich and cause engine malfunction.

b) The bolt tightening torque is 80 kg-cm.

8-2-5 FLOAT SYSTEM

(1) Pull out the float pin (8) and remove the float (7) and needle valve (6).

CAUTION

When cleaning the jets, use neither a drill nor a wire (because of possible damage to the orifice which will adversely affect fuel flow). Be sure to use compressed air to blow them clean.

(2) When removing the needle valve and floats, gently tap the reverse side using the rod more slender than the float pin and remove, since the float pin is calked to the carburetor body.

9. STARTING SYSTEM

9-1 RECOIL STARTER

When repairing recoil starter, disassemble and re-assemble in the following procedures.

Tools: Socket wrench, Needle nose pliers, Screw driver

9-1-1 HOW TO DISASSEMBLY

- (1) Remove recoil starter from engine.
- (2) Pull starter knob and pull out starter rope for 30-40cm to line up notch on reel with outlet hole for starter rope.

Hold reel with thumb and pull starter rope inside the starter case with screw driver.

(See Fig. 9-1 or 9-2.)

Rewind reel clockwise until the rotation stops.

When rewinding the reel, control the rotation by holding starter rope using the notch on the reel and pressing the reel with thumb.

- (3) Remove parts in the following order.

1. Return spring
2. Ratchet
3. Friction spring
4. Ratchet guide
5. Set screw

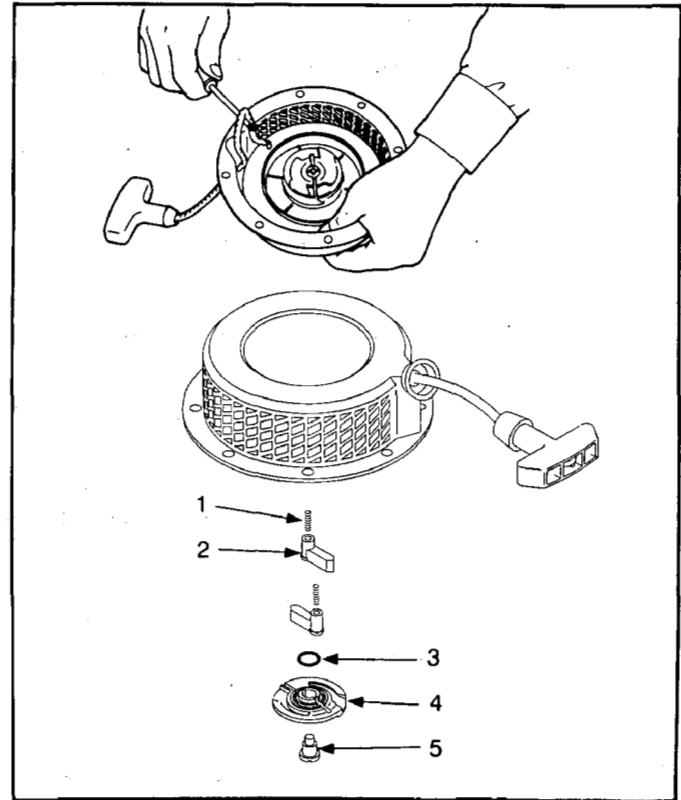

Fig. 9-1 (Classic Steel)

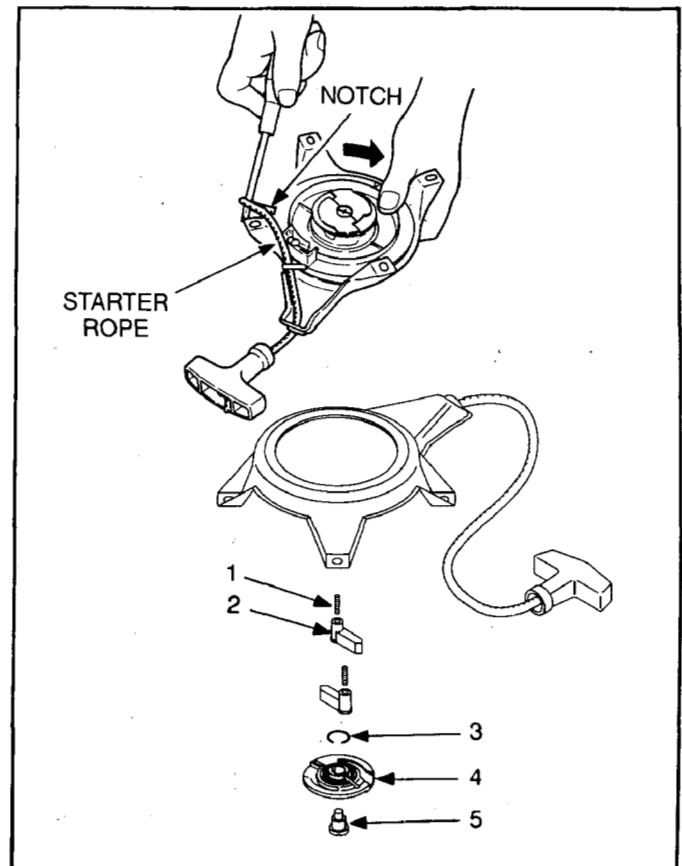

Fig. 9-2 (Pro Poly)

(4) Remove the reel from the starter case as shown in Fig. 9-3.

Take out the reel slowly turning it lightly towards the left and right to remove spring from the hook. Do not remove the reel quickly or the spring may escape from the starter case. Untie the starter rope from the knob and remove.

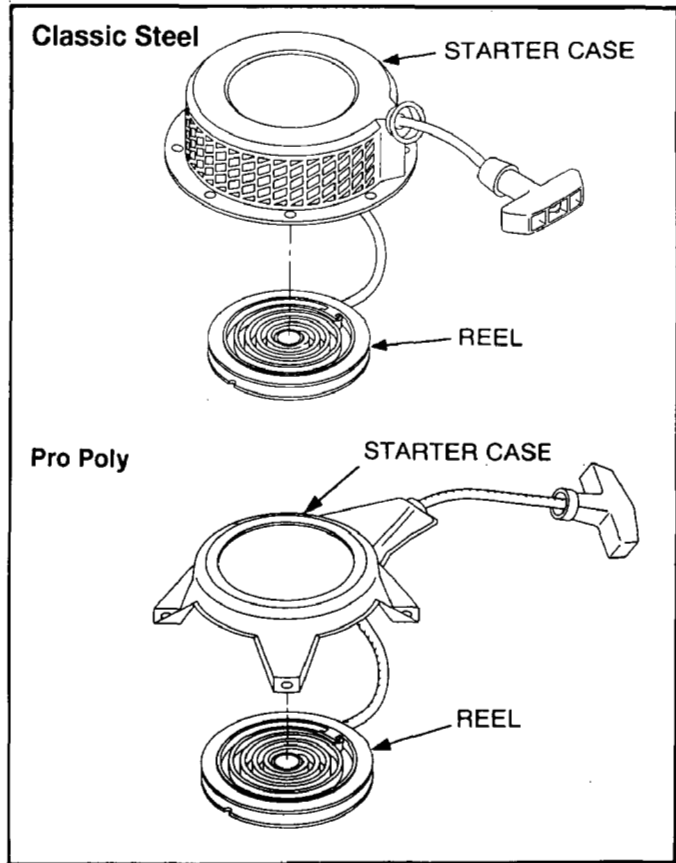

Fig. 9-3

9-1-2 HOW TO REASSEMBLE

(1) Put the starter rope through the starter knob and tie it as shown in Fig. 9-4. (Tie the rope tightly for the safety sake.)

Put the opposite side of the rope through the starter case and reel. Tie it in the same way as the starter knob end and put the knot in the reel completely.

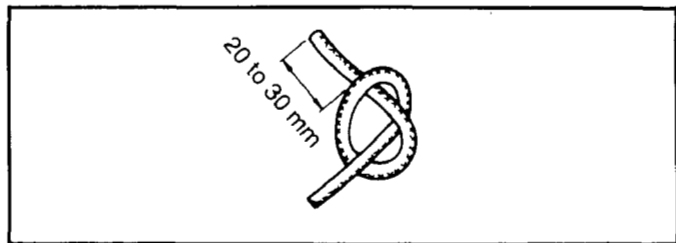

Fig. 9-4

(2) Check that the spring is securely set in the reel. Adjust the position of inner end of the spring so it hooks on hook in the starter case securely. The shape of starter spring inner end may be adjusted with a plier if necessary.

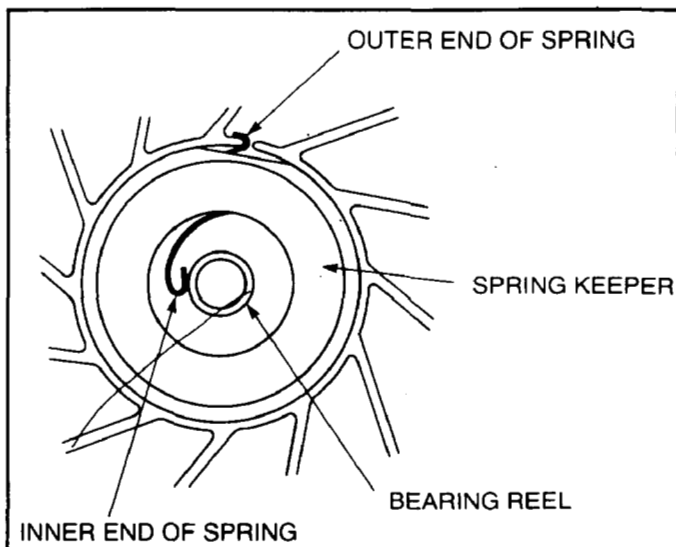

Fig. 9-5

- (3) Prior to installing the reel in the starter case, wind the starter rope in the reel for 2.5 turns in the arrowhead direction as shown in Fig. 9-6. Then let the rope out of the reel from the reel notch. Line up the reel hook with the inner end of the spring and install the reel in the starter case.

Check that the inner end of spring is securely hooked onto the hook.

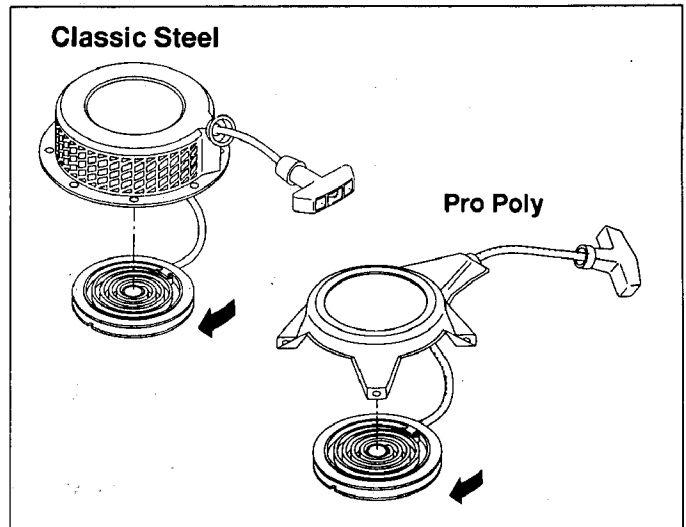

Fig. 9-6

- (4) Reassemble the parts in reverse order of disassembly.

Check that the ratchets are pushed by the ratchet springs toward the center of the recoil.

Install the friction plate with its two bosses set inside of the bent portion of ratchets.

Apply small amount of lock-tight to the center screw and torque it.

Thightening torque
3.9 N•m
4.0 kg•cm
2.9 ft•lb

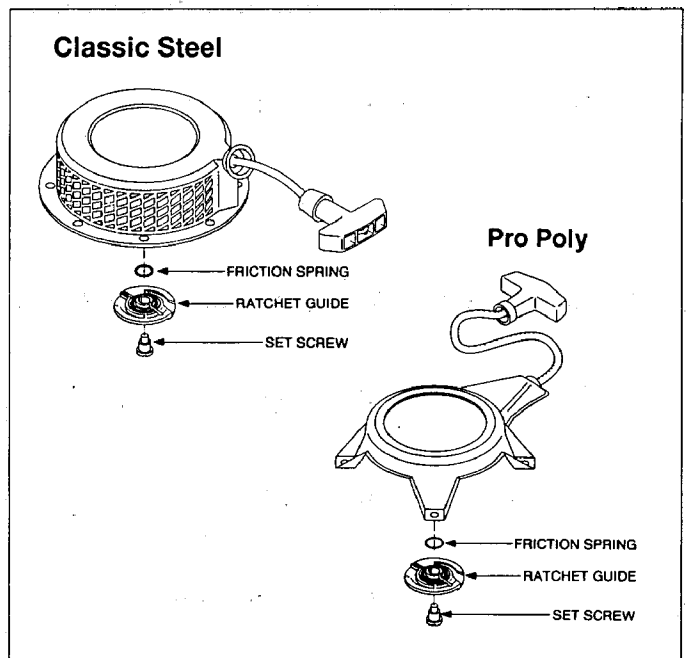

Fig. 9-7

- (5) Hold starter rope as shown in Fig. 9-8 and turn reel 4 times in the arrowhead direction.

Firmly press the reel not to allow reverse turn and pull starting knob to let starter rope out of starter case.

Return knob slowly to let starter rope rewind in reel.

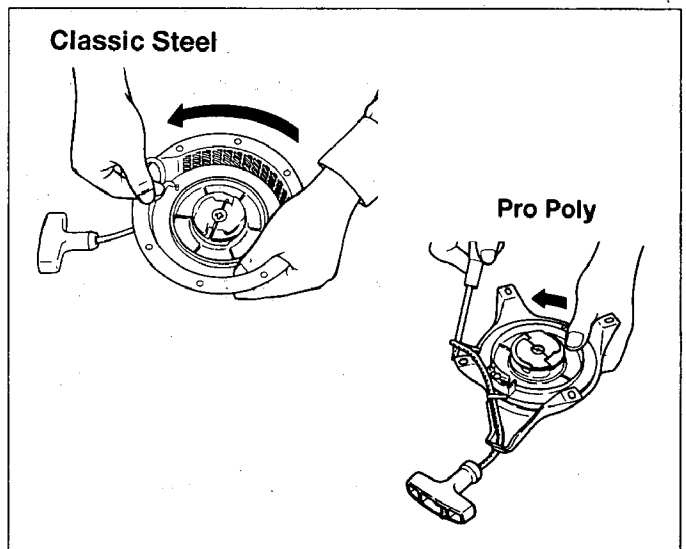

Fig. 9-8

- (6) Test the operation of the recoil starter to see if the rope recoils satisfactorily and the ratchets project and retract properly. Mount the recoil starter to the engine.
- (7) If the spring escapes from the reel when disassembling the recoil, hook the outer end of the spring onto the notch of the reel and rewind the spring into the housing.
- (8) Lubricate the rotating parts, sliding parts and spring with heat resistant grease or mobile oil when reassembling the recoil and prior to long term storage.

10. TROUBLESHOOTING

The following three conditions must be fulfilled for satisfactory engine start.

1. The cylinder filled with a proper fuel-air mixture.
2. Good compression in the cylinder.
3. Good spark, properly timed, to ignite the mixture.

The engine cannot be started unless these three conditions are met. There are also other factors which make engine start difficult, e. g., a heavy load on the engine when it is about to start at low speed, and a high back pressure due to a long exhaust pipe.

The most common causes of engine troubles are given below:

10-1 STARTING DIFFICULTIES

10-1-1 FUEL SYSTEM

- (1) No gasoline in the fuel tank ; or the fuel cock closed.
- (2) The carburetor is not choked sufficiently, especially when the engine is cold.
- (3) Water, dust or gum in the gasoline interfering the fuel flow to the carburetor.
- (4) Inferior grade gasoline or poor quality gasoline is not vaporized enough to produce the correct fuel-air mixture.
- (5) The carburetor needle valve is held open by dirt or gum. This trouble can be detected as the fuel flows out of the carburetor when the engine is idling. (Overflow)
This trouble may be remedied, depending on cases, by lightly tapping the float chamber with the grip of a screwdriver or the like.
- (6) If the carburetor overflows, excessive fuel runs into the cylinder when starting the engine, making the fuel-air mixture too rich to burn. If this happens, remove the spark plug, and turn the starting pulley a few turns in order to let the rich fuel-air mixture out of the spark plug hole into the atmosphere. Keep the carburetor choke open during this operation. Dry the spark plug well, screw it into place, and try to start again.

10-1-2 COMPRESSION SYSTEM

If starting difficulties and loss of power are not due to the fuel system or ignition system, the following must be checked for possible lack of compression.

- (1) Engine inside is completely dried up because of a long period of storage.
- (2) Loose or broken spark plug. This causes a hissing noise made by mixture gas running out of cylinder in compression stroke during cranking.
- (3) Damaged head gasket or loose cylinder head. A similar hissing noise is produced during compression stroke.
- (4) Incorrect valve clearance

If the correct compression is not obtained even after remedying the above, disassemble the engine and check further as follows:

- a) Valve stuck open due to carbon or gum on the valve stem.
- b) If the piston rings are stuck on the piston, remove the piston and connecting rod from the engine. Clean or replace the parts.

10-1-3 IGNITION SYSTEM

Check the followings for lack of spark .

- (1) Leads of the ignition coil or spark plug.
- (2) Ignition coil damaged and shorted.
- (3) Spark plug cable wet or soaked with oil.
- (4) Spark plug dirty or wet.
- (5) Spark plug electrode gap incorrect.
- (6) Spark plug electrodes are connected or bridged.
- (7) Incorrect spark timing.

10-2 ENGINE MISFIRES

- (1) Incorrect spark plug electrode gap. Adjust it to anywhere between 0.7 and 0.8mm.
- (2) Ignition cable worn and leaking.
- (3) Sparks weak.
- (4) Ignition wire connections loose.
- (5) Water in gasoline.
- (6) Insufficient compression.

10-3 ENGINE STOPS

- (1) Fuel tank empty. Water, dirt, gum, etc. in gasoline.
- (2) Vapor lock, i. e., gasoline evaporating in the fuel lines due to overheat around the engine.
- (3) Vapor lock in the fuel lines or carburetor due to the use of too volatile winter gas in the hot season.
- (4) Air vent hole in the fuel tank cap plugged.
- (5) Bearing parts seized due to lack of oil.
- (6) Magneto or ignition coil faulty.

10-4 ENGINE OVERHEATS

- (1) Crankcase oil level low. Add oil immediately.
- (2) Spark timing incorrect.
- (3) Low grade gasoline is used, or engine is overloaded.
- (4) Cooling air circulation restricted.
- (5) Cooling air path misdirected causes loss of cooling efficiency.
- (6) Cylinder head cooling fins clogged up with dirt.
- (7) Engine operated in an enclosed space without sufficient cooling air.
- (8) Exhaust gas discharge restricted, or carbon deposits in the combustion chamber.
- (9) Engine running on low - octane gasoline detonates due to heavy load at low speed.

10-5 ENGINE KNOCKS

- (1) Poor quality gasoline.
- (2) Engine operating under heavy load at low speed.
- (3) Carbon or lead deposits in the cylinder head.
- (4) Spark timing incorrect.
- (5) Loose connecting rod bearing due to wear.
- (6) Loose piston pin due to wear.
- (7) Engine overheated.

10-6 ENGINE BACKFIRES THROUGH CARBURETOR

- (1) Water or dirt in gasoline, or low-grade gasoline.
- (2) Intake valve stuck.
- (3) Valves overheated, or hot carbon particles in the combustion chamber.
- (4) Engine cold.

11. INSTALLATION

Engine life, ease of maintenance and inspection, frequency of checks and repairs, and operating cost all depend on the way in which the engine is installed. Carefully observe the following instructions for installing the engine.

11-1 INSTALLING

When mounting the engine, carefully examine its position, the method of connecting it to a machine, the foundation, and the method of supporting the engine.

When determining its mounting position, in particular, make sure that gasoline and oil can easily be supplied and checked, the spark plug can easily be checked, the air cleaner can easily be serviced, and that the oil can easily be discharged.

11-2 VENTILATION

Fresh air is necessary for cooling the engine and burning the fuel.

In the case the engine is operated under a hood or in a small room, temperature rise in the engine room can cause vapor lock, oil deterioration, increased oil consumption, loss of power, piston seizure, shorter engine life, etc., making it impossible to operate the engine properly. It is necessary, therefore, to provide a duct or baffle to guide cooling air to the engine to prevent recirculation of the hot air used for engine cooling, and temperature rise of the machine.

Keep the engine room temperature below 50°C even in the hottest period of the year.

11-3 EXHAUST GAS DISCHARGE

Exhaust gas is noxious. When operating the engine indoors, be sure to discharge the exhaust gas outdoors. If a long exhaust pipe is used in such a case, the internal resistance increases causing loss of engine power. Thus pipe inside diameter must be increased in proportion to exhaust pipe length.

Exhaust pipe: Less than 3m long, pipe inside diameter 25 mm,
Less than 5m long, pipe inside diameter 30 mm.

12. SERVICE DATA

“STD” in the following table is the parts dimension from the brand new engine or the spare parts. Whereas, “Limit” shows the maximum allowance for the parts to be used on the engine. If the measurement exceeds beyond the “Limit”, the part needs to be replaced and/or repaired.

12-1 CLEARANCE DATA AND LIMITS

Unit : mm (in)

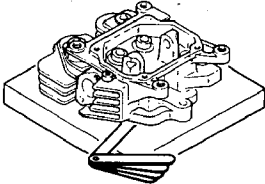
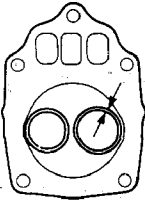
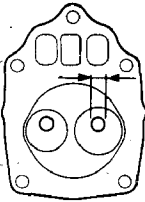
ITEM		STD	Limit
CYLINDER HEAD ● Flatness 		LESS THAN 0.05 (0.002)	0.1 (0.004)
● Valve seat contact width 	IN. EX.	0.7 ~ 1.0 (0.028 ~ 0.039)	2.0 (0.079)
● Valve guide inside dia. 		5.500 ~ 5.518 (0.2165 ~ 0.2172)	5.65 (0.2224)

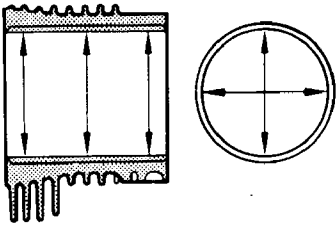
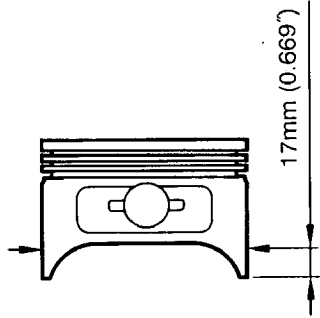
ITEM	STD	Lmit
<p>CYLINDER</p> <ul style="list-style-type: none"> ● Inside dia. 	STD	67.000 ~ 67.019 (2.6378 ~ 2.6385)
	1st re boring	67.250 ~ 67.269 (2.6476 ~ 2.6484)
	2nd re boring	67.500 ~ 67.519 (2.6575 ~ 2.6582)
<ul style="list-style-type: none"> ● Roundness after re boring. 		LESS THAN 0.01 (0.004)
<ul style="list-style-type: none"> ● Cylindricity after re boring. 		LESS THAN 0.015 (0.0006)
<p>PISTON</p> <ul style="list-style-type: none"> ● Piston size (At skirt in thrust direction) 	STD	66.96 ~ 66.98 (2.6362 ~ 2.6370)
	1st o/s	67.21 ~ 67.23 (2.6461 ~ 2.6469)
	2nd o/s	67.46 ~ 67.48 (2.6559 ~ 2.6567)

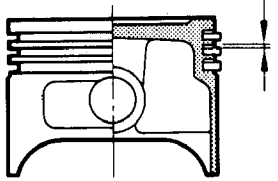
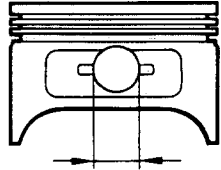
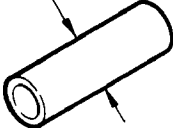
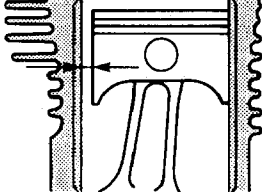
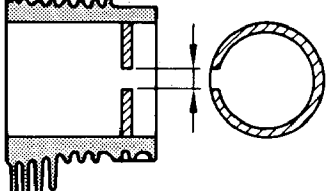
ITEM		STD	Limit
<ul style="list-style-type: none"> ● Ring groove side clearance 	Top	0.050 ~ 0.095 (0.0019 ~ 0.0037)	0.16 (0.006)
	2nd	0.040 ~ 0.085 (0.0016 ~ 0.0030)	0.16 (0.006)
	Oil ring	0 ~ 0.035 (0 ~ 0.0014)	0.12 (0.006)
<ul style="list-style-type: none"> ● Piston pin hole 		13.991 ~ 14.002 (0.5508 ~ 0.5513)	14.035 (0.6313)
<ul style="list-style-type: none"> ● Piston pin outside dia. 		13.992 ~ 14.000 (0.5508 ~ 0.5512)	13.960 (0.6284)
<ul style="list-style-type: none"> ● Clearance between piston and cylinder at skirt area. 		0.020 ~ 0.059 (0.0008 ~ 0.0023)	0.23 (0.010)
<ul style="list-style-type: none"> ● Piston ring end gap 			
	Top 2nd	0.05 ~ 0.25 (0.0020 ~ 0.098)	1.3 (0.0091)
	oil ring	0.3 ~ 0.9 (0.0118 ~ 0.0354)	2.1 (0.0591)

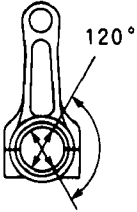
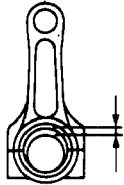
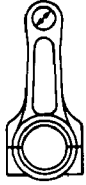
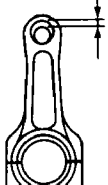
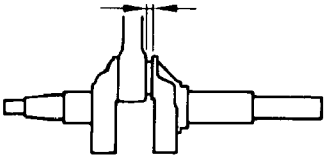
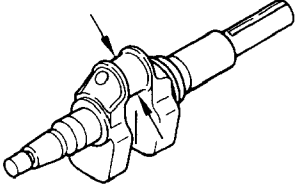
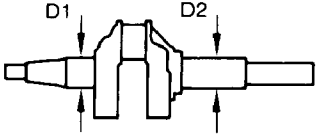
ITEM	STD	Limit
CONNECTING ROD ● Big end inside dia. 	26.000 ~ 26.013 (1.0236 ~ 1.0241)	26.1 (1.1850)
● Clearance between big end and crankpin 	0.037 ~ 0.063 (0.0015 ~ 0.0024)	0.2 (0.008)
● Small end inside dia. 	14.010 ~ 14.021 (0.5516 ~ 0.5520)	14.08 (0.6331)
● Clearance between small end and piston pin 	0.010 ~ 0.029 (0.0004 ~ 0.0011)	0.12 (0.0047)
● Big end side clearance 	0.1 ~ 0.3 (0.0039 ~ 0.0118)	0.5 (0.040)
CRANKSHAFT ● Crankpin outside dia. 	25.950 ~ 25.963 (1.0217 ~ 1.0221)	25.84 (1.1752)
● Journal dia. 	D1, D2 24.988 ~ 24.997 (0.9838 ~ 0.9841)	

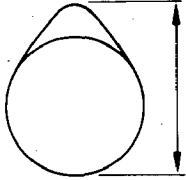
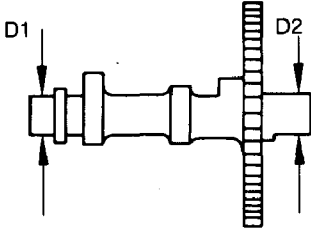
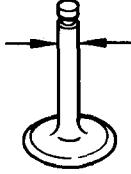
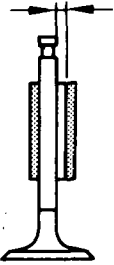
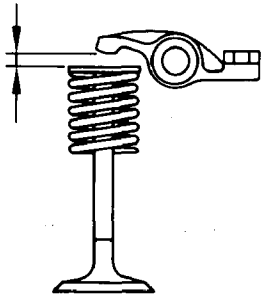
ITEM		STD	Limit
<p>CAMSHAFT</p> <ul style="list-style-type: none"> ● Cam height  <ul style="list-style-type: none"> ● Journal outside dia. "D" type 	IN.EX. CAMS	29.6 ~ 29.8 (1.165 ~ 1.173)	29.45 (1.159)
	D1	16.973 ~ 16.984 (0.6682 ~ 0.6687)	16.95 (0.6673)
	D2	14.973 ~ 14.984 (0.5895 ~ 0.5899)	14.95 (0.5886)
<p>VALVE</p> <ul style="list-style-type: none"> ● Valve stem outside dia.  <ul style="list-style-type: none"> ● Clearance between valve stem dia. and valve guide  <ul style="list-style-type: none"> ● Valve clearance 	IN.	5.440 ~ 5.455 (0.2142 ~ 0.2148)	5.35 (0.2106)
	EX.	5.426 ~ 5.444 (0.2136 ~ 0.2143)	5.35 (0.2106)
	IN.	0.045 ~ 0.078 (0.0018 ~ 0.0031)	0.3 (0.012)
	EX.	0.056 ~ 0.092 (0.0022 ~ 0.0036)	0.3 (0.012)
	IN./EX. (cold)	0.085 ~ 0.115 (0.0033 ~ 0.0045)	

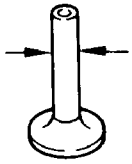
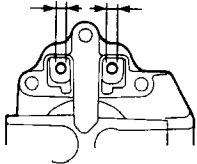
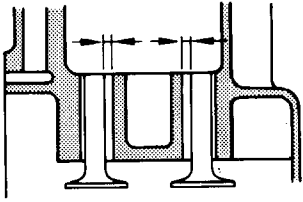
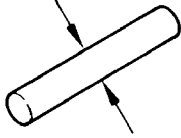
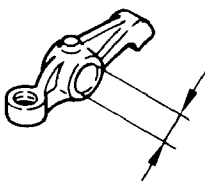
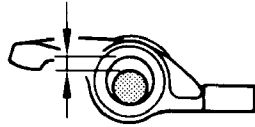
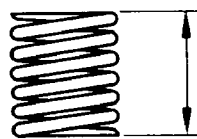
ITEM	STD	Limit
<p>TAPPET</p> <ul style="list-style-type: none"> ● Stem outside dia.  <ul style="list-style-type: none"> ● Guide inside dia.  <ul style="list-style-type: none"> ● Tappet guide clearance 	<p>7.960 ~ 7.975 (0.3134 ~ 0.3140)</p>	
<p>ROCKER ARM</p> <ul style="list-style-type: none"> ● Rocker shaft outside dia. 	<p>11.995 ~ 12.000 (0.4722 ~ 0.4724)</p>	<p>11.92 (0.4693)</p>
<ul style="list-style-type: none"> ● Rocker arm hole dia. 	<p>12.016 ~ 12.034 (0.4731 ~ 0.4738)</p>	
<ul style="list-style-type: none"> ● Rocker arm shaft clearance 	<p>0.016 ~ 0.039 (0.0006 ~ 0.0015)</p>	
<p>VALVE SPRING FREE LENGTH</p> 	<p>30.5 (1.2)</p>	<p>—</p>

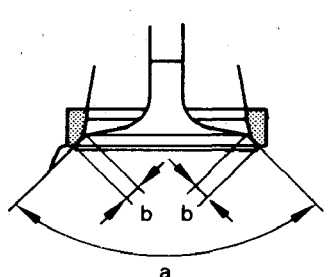
ITEM	STD	Limit
<ul style="list-style-type: none"> ● Valve cutter angle(a) ● Valve contact width(b) 	<p>a : 90° b : 0.7 ~ 1.0 (0.028 ~ 0.039)</p>	<p>2.0 (0.079)</p>

12-2 TORQUE SPECIFICATIONS

DESCRIPTION		TIGHTENING TORQUE		
		kg·cm	N·m	ft·lb
Cylinder head bolts		230 ~ 270	22.5 ~ 26.5	16.6 ~ 19.5
Connecting rod cap bolts		170 ~ 200	16.6 ~ 19.6	12.2 ~ 14.4
Flywheel nut		600 ~ 650	58.8 ~ 63.7	43 ~ 47
Main bearing cover bolts		80 ~ 100	7.8 ~ 9.8	5.7 ~ 7.2
Spark plug	New spark plug	120 ~ 150	11.8 ~ 14.7	8.7 ~ 10.9
	Retightening	230 ~ 270	22.6 ~ 26.5	16.6 ~ 19.5

12-3 OIL GRADE CHART

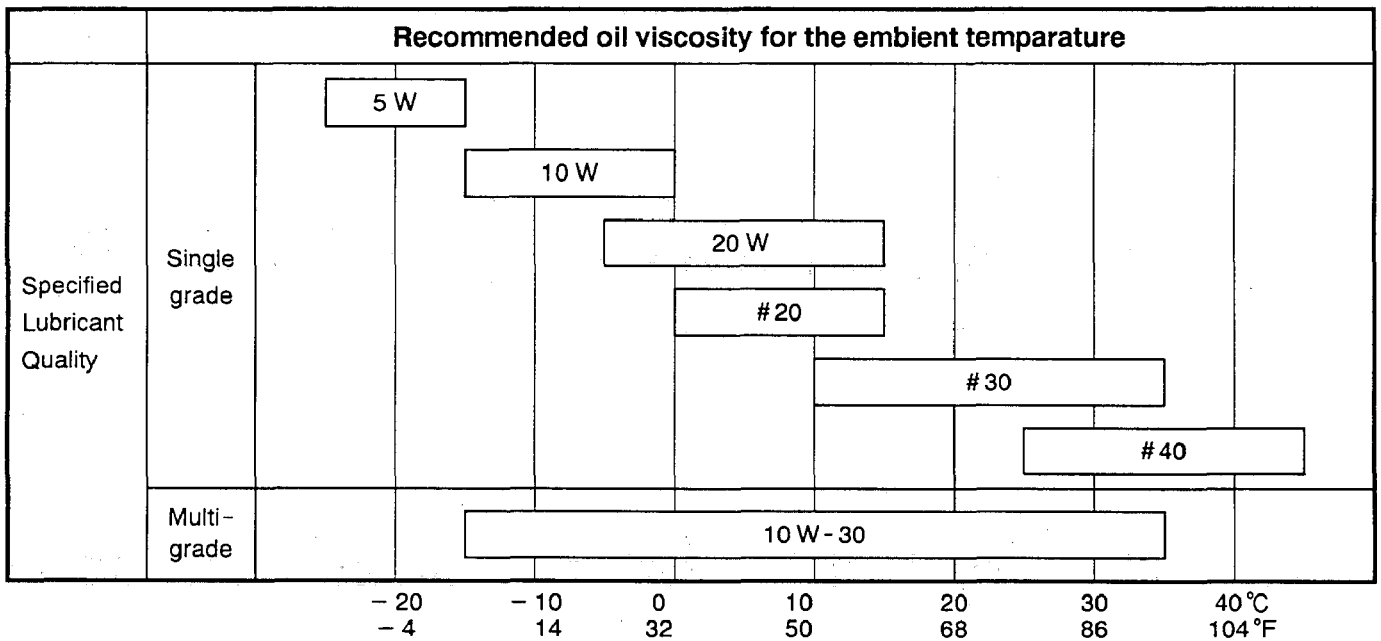

Use oil classified as SC or higher.

Multi-grade oil tends to increase its consumption at high ambient temperature.

13. MAINTENANCE AND STORAGE

The following maintenance jobs apply when the engine is operated correctly under normal conditions. The indicated maintenance intervals are by no means guarantee maintenance free operations during these intervals.

For example, if the engine is operated in extremely dusty conditions, the air cleaner should be cleaned every day instead of every 50 hours.

13-1 DAILY MAINTENANCE (EVERY 8 HRS.)

MAINTENANCE	REMARKS	REFER
1) Clean away dust and chaff from engine.	Governor linkage is especially sensitive to dust.	Read instruction for use.
2) Check fuel leakage from fuel system. If any, retighten fasteners or replace necessary parts.		Read instruction for use.
3) Inspect for loose hardware and retighten if necessary.	Loose bolts and nuts may come off and result in breakage of other parts.	Read instruction for use.
4) Check oil level and add to full mark.		Read instruction for use.

13-2 INITIAL 20 HOURS. MAINTENANCE

MAINTENANCE	REMARKS	REFER
1) Change crankcase oil.	To remove sludge from run-in operation.	Read instruction for use.

13-3 EVERY 50 HOURS. (10 DAYS) MAINTENANCE

MAINTENANCE	REMARKS	REFER
1) Change crankcase oil.	Contaminated oil quickens wear.	Read instruction for use.
2) Clean air cleaner.		Read instruction for use.
3) Check and clean spark plug.	If dirty, wash in gasoline or polish with emery paper.	Read instruction for use.
4) Clean cooling system.		Read instruction for use.

13-4 EVERY 100~200 HOURS. (MONTHLY) MAINTENANCE

MAINTENANCE	REMARKS	REFER
1) Inspect cooling system and remove dirt and chaff.	Remove blower housing and clean up between fins and housing.	Consult your nearest Robin dealer.
2) Clean and adjust spark plug gap.		Read instruction for use.
3) Change oil filter.		Read instruction for use.

13-5 EVERY 500~600 HOURS. MAINTENANCE

MAINTENANCE	REMARKS	REFER
1) Remove carbon from cylinder head.	Carbon deposits in combustion chamber causes lack of power.	Consult your nearest Robin dealer.
2) Disassemble and clean carburetor.		Consult your nearest Robin dealer.
3) Clean fuel tank.		Consult your nearest Robin dealer.
4) Adjust valve clearance.		Consult your nearest Robin dealer.
5) Replace spark plug.		Consult your nearest Robin dealer.
6) Overhaul engine		Consult your nearest Robin dealer.

13-6 EVERY 1000 HOURS. (YEARLY) MAINTENANCE

MAINTENANCE	REMARKS	REFER
1) Replace fuel lines once a year.	Avoid hazards caused by fuel leakage.	Consult your nearest Robin dealer.

13-7 ENGINE STORAGE

- (1) Perform the above 13-1 and 13-2 maintenance jobs.
- (2) Drain fuel from the fuel tank and carburetor float chamber.
- (3) To prevent rust in the cylinder bore, apply oil through the spark plug hole and turn the crankshaft several turns by hand. Reinstall the plug.
- (4) Turn the starting pulley by hand and leave it where the resistance is the heaviest.
- (5) Clean outside of the engine with oiled cloth.
- (6) Put a plastic cover or the like over the engine and store the engine in dry place.



Robin America, Inc.

940 Lively Blvd., Wood Dale, IL 60191 • Tel: (708) 350-8200 • Fax: (708) 350-8212