

Robin Industrial Engines®

SERVICE MANUAL

Models

**EH12-2, EH17-2,
EH25-2
Engines**

PUB-ES1154
Rev. 5/99

Robin
SUBARU

CONTENTS

<i>Section</i>	<i>Title</i>	<i>Page</i>
1.	SPECIFICATIONS	1
2.	PERFORMANCE	4
2-1	Maximum Output	4
2-2	Continuous Rated Output	4
2-3	Maximum Torque	4
2-4	Performance Curves	5
3.	FEATURES	8
4.	GENERAL DESCRIPTION OF ENGINE COMPONENTS	8
4-1	Cylinder And Crankcase	8
4-2	Main Bearing Cover	8
4-3	Crankshaft	9
4-4	Connecting Rod And Piston	9
4-5	Piston Rings	9
4-6	Camshaft	10
4-7	Valve Arrangement	10
4-8	Cylinder Head	10
4-9	Governor System	11
4-10	Cooling System	11
4-11	Lubrication	11
4-12	Ignition System	11
4-13	Carburetor	12
4-14	Air Cleaner	12
4-15	Balancer (Option for EH25-2)	12
4-16	Decompression System	13
4-17	Sectional View of Engine	14
5.	DISASSEMBLY AND REASSEMBLY	16
5-1	Cautions	16
5-2	Special Tools	16
5-3	Disassembly Procedures	17
5-4	Reassembly Procedures	32
5-5	Break-In Operation	43
6.	IGNITION SYSTEM	43
6-1	Type of Ignition System	43
6-2	Basic Theory	43
6-3	Wiring Diagram	45
7.	AUTOMATIC DECOMPRESSION SYSTEM	46
8.	CARBURETOR	47
8-1	Operation And Construction	47
8-2	Disassembly And Reassembly	48

<i>Section</i>	<i>Title</i>	<i>Page</i>
9.	STARTING SYSTEM	50
9-1	Recoil Starter	50
10.	TROUBLESHOOTING	54
10-1	Starting Difficulties	54
10-2	Engine Misfires	55
10-3	Engine Stops	55
10-4	Engine Overheats	55
10-5	Engine Knocks	56
10-6	Engine Backfires Through Carburetor	56
11.	INSTALLATION	57
11-1	Installing	57
11-2	Ventilation	57
11-3	Exhaust Gas Discharge	57
11-4	Power Transmission To Driven Machines	57
12.	SERVICE DATA	58
12-1	Clearance Data And Limits	58
12-2	Torque Specifications	70
12-3	Oil Grade Chart	71
13.	MAINTENANCE AND STORAGE	72
13-1	Daily Maintenance	72
13-2	Initial 20 Hours Maintenance	72
13-3	Every 50 Hours (10 Days)Maintenance	72
13-4	Every 100~200 Hours (Monthly) Maintenance	73
13-5	Every 500~600 Hours Maintenance	73
13-6	Every 1000 Hours (Yearly) Maintenance	73
13-7	Engine Storage	73

1. SPECIFICATIONS

Model		EH12-2			
		EH12-2B	EH12-2BS	EH12-2D	EH12-2DS
Type		Air-Cooled, 4-Cycle, Single-Cylinder, Horizontal P.T.O. Shaft, Gasoline Engine			
Bore × Stroke		60 × 43 mm (2.36 × 1.57 in.)			
Piston Displacement		121 cm ³ (7.38 cu.in.)			
Compression Ratio		9.0			
Output KW (HP)/rpm	Continuous	1.8 (2.5) / 1500	2.1 (2.8) / 1800	1.8 (2.5) / 3000	2.1 (2.8) / 3600
	Max.	2.9 (4.0) / 2000		2.9 (4.0) / 4000	
Max. Torque N·m (kgf·m)/rpm		15 (1.52) / 1300		7.5 (0.76) / 2600	
Direction of Rotation		Counterclockwise As Viewd From P.T.O. Shaft Side			
Cooling system		Forced Air Cooling			
Valve Arrangement		Overhead Valve			
Lubrication		Splash Type			
Lubricant		Automobile Oil SAE #20, #30 or 10W-30 ; Class SE, SF or higher			
Capacity of Lubricant		0.6 L (0.16 U.S. gal.)			
Carburetor		Horizontal Draft, Float Type			
Fuel		Automobile Gasoline			
Fuel Consumption Rate		310 g/KW·h (230 gr/HP·h) At Continuous Rated Output			
Fuel Feed System		Gravity Type			
Fuel Tank Capacity		3.6 L (0.95 U.S. gal.)			
Ignition System		Flywheel Magneto (Solid State)			
Spark Plug		NGK B6ES			
Charging Capacity		–	12V – 1.3A	–	12V – 1.3A
Starting System		Recoil Starter	Recoil and Electric Starter	Recoil Starter	Recoil and Electric Starter
Speed Reduction		2:1 Cam Shaft Drive		–	
Governor System		Centrifugal Flyweight System			
Dry Weight		15.5 kg (34.2 lb.)	18.0 kg (39.7 lb.)	15.0 kg (33.1 lb.)	17.5 kg (38.6 lb.)
Dimensions	Length	299 mm (11.77 in.)	299 mm (11.77 in.)	297 mm (11.69 in.)	297 mm (11.69 in.)
	Width	330 mm (12.99 in.)	341 mm (13.43 in.)	330 mm (12.99 in.)	341 mm (13.43 in.)
	Height	366 mm (14.41 in.)	366 mm (14.41 in.)	366 mm (14.41 in.)	366 mm (14.41 in.)

Model		EH17-2			
		EH17-2B	EH17-2BS	EH17-2D	EH17-2DS
Type		Air-Cooled, 4-Cycle, Single-Cylinder, Horizontal P.T.O. Shaft, Gasoline Engine			
Bore × Stroke		67 × 49 mm (2.64 × 1.93 in.)			
Piston Displacement		172 cm ³ (10.50 cu.in.)			
Compression Ratio		8.5			
Output KW (HP)/rpm	Continuous	2.6 (3.5) / 1500 2.9 (4.0) / 1800		2.6 (3.5) / 3000 2.9 (4.0) / 3600	
	Max.	4.4 (6.0) / 2000		4.4 (6.0) / 4000	
Max. Torque N·m (kgf·m)/rpm		21.4 (2.18) / 1300		10.7 (1.09) / 2600	
Direction of Rotation		Counterclockwise As Viewd From P.T.O. Shaft Side			
Cooling system		Forced Air Cooling			
Valve Arrangement		Overhead Valve			
Lubrication		Splash Type			
Lubricant		Automobile Oil SAE #20, #30 or 10W-30 ; Class SE, SF or higher			
Capacity of Lubricant		0.65 L (0.17 U.S. gal.)			
Carburetor		Horizontal Draft, Float Type			
Fuel		Automobile Gasoline			
Fuel Consumption Rate		310g/KW·h (230 gr/HP·h) At Continuous Rated Output			
Fuel Feed System		Gravity Type			
Fuel Tank Capacity		3.6 L (0.95 U.S. gal.)			
Ignition System		Flywheel Magneto (Solid State)			
Spark Plug		NGK B6HS			
Charging Capacity		–	12V – 1.3A	–	12V – 1.3A
Starting System		Recoil Starter	Recoil and Electric Starter	Recoil Starter	Recoil and Electric Starter
Speed Reduction		2:1 Cam Shaft Drive		–	
Governor System		Centrifugal Flyweight System			
Dry Weight		16.5 kg (36.4 lb.)	19.0 kg (41.9 lb.)	16.0 kg (35.3 lb.)	18.5 kg (40.8 lb.)
Dimensions	Length	301 mm (11.85 in.)	301 mm (11.85 in.)	299 mm (11.77 in.)	299 mm (11.77 in.)
	Width	330 mm (12.99 in.)	341 mm (13.43 in.)	330 mm (12.99 in.)	341 mm (13.43 in.)
	Height	380 mm (14.96 in.)	380 mm (14.96 in.)	380 mm (14.96 in.)	380 mm (14.96 in.)

Model		EH25-2			
		EH25-2B	EH25-2BS	EH25-2D	EH25-2DS
Type		Air-Cooled, 4-Cycle, Single-Cylinder, Horizontal P.T.O. Shaft, Gasoline Engine			
Bore × Stroke		75 × 57 mm (2.95 × 2.24 in.)			
Piston Displacement		251 cm ³ (15.31 cu.in.)			
Compression Ratio		8.5			
Output KW (HP)/rpm	Continuous	4.0 (5.5) / 1500	4.7 (6.4) / 1800	4.0 (5.5) / 3000	4.7 (6.4) / 3600
	Max.	6.3 (8.5) / 2000		6.3 (8.5) / 4000	
Max. Torque N·m (kgf·m)/rpm		33.1 (3.38) / 1300		16.6 (1.69) / 2600	
Direction of Rotation		Counterclockwise As Viewd From P.T.O. Shaft Side			
Cooling system		Forced Air Cooling			
Valve Arrangement		Overhead Valve			
Lubrication		Splash Type			
Lubricant		Automobile Oil SAE #20, #30 or 10W-30 ; Class SE, SF or higher			
Capacity of Lubricant		1.0 L (0.26 U.S. gal.)			
Carburetor		Horizontal Draft, Float Type			
Fuel		Automobile Gasoline			
Fuel Consumption Rate		310g/KW·h (230 gr/HP·h) At Continuous Rated Output			
Fuel Feed System		Gravity Type			
Fuel Tank Capacity		6.0 L (1.59 U.S. gal.)			
Ignition System		Flywheel Magneto (Solid State)			
Spark Plug		NGK B6HS			
Charging Capacity		–	12V – 1.3A	–	12V – 1.3A
Starting System		Recoil Starter	Recoil and Electric Starter	Recoil Starter	Recoil and Electric Starter
Speed Reduction		2:1 Cam Shaft Drive		–	
Governor System		Centrifugal Flyweight System			
Dry Weight		24.0 kg (52.9 lb.)	28.0 kg (61.7 lb.)	23.0 kg (50.7 lb.)	27.0 kg (59.5 lb.)
Dimensions	Length	333 mm (13.11 in.)	333 mm (13.11 in.)	332 mm (13.07 in.)	332 mm (13.07 in.)
	Width	380 mm (14.96 in.)	380 mm (14.96 in.)	380 mm (14.96 in.)	380 mm (14.96 in.)
	Height	440 mm (17.32 in.)	440 mm (17.32 in.)	440 mm (17.32 in.)	440 mm (17.32 in.)

2. PERFORMANCE

2-1 MAXIMUM OUTPUT

The maximum output is the output of an engine with its throttle valve fully opened under the condition that all the moving parts are properly worn in after the initial break-in period.

A new engine may not produce full maximum output while its moving parts are still not broken-in.

2-2 CONTINUOUS RATED OUTPUT

The continuous rated output is the output of an engine at optimum governed speed which is most favorable from the view point of engine's life and fuel consumption.

When the engine is installed on a certain equipment, it is recommended that the continuous output required from the engine be kept below this continuous rated output.

2-3 MAXIMUM TORQUE

The maximum torque is the torque at the output shaft when the engine is producing maximum output at certain revolution.

2-4 PERFORMANCE CURVES

● EH12D, B

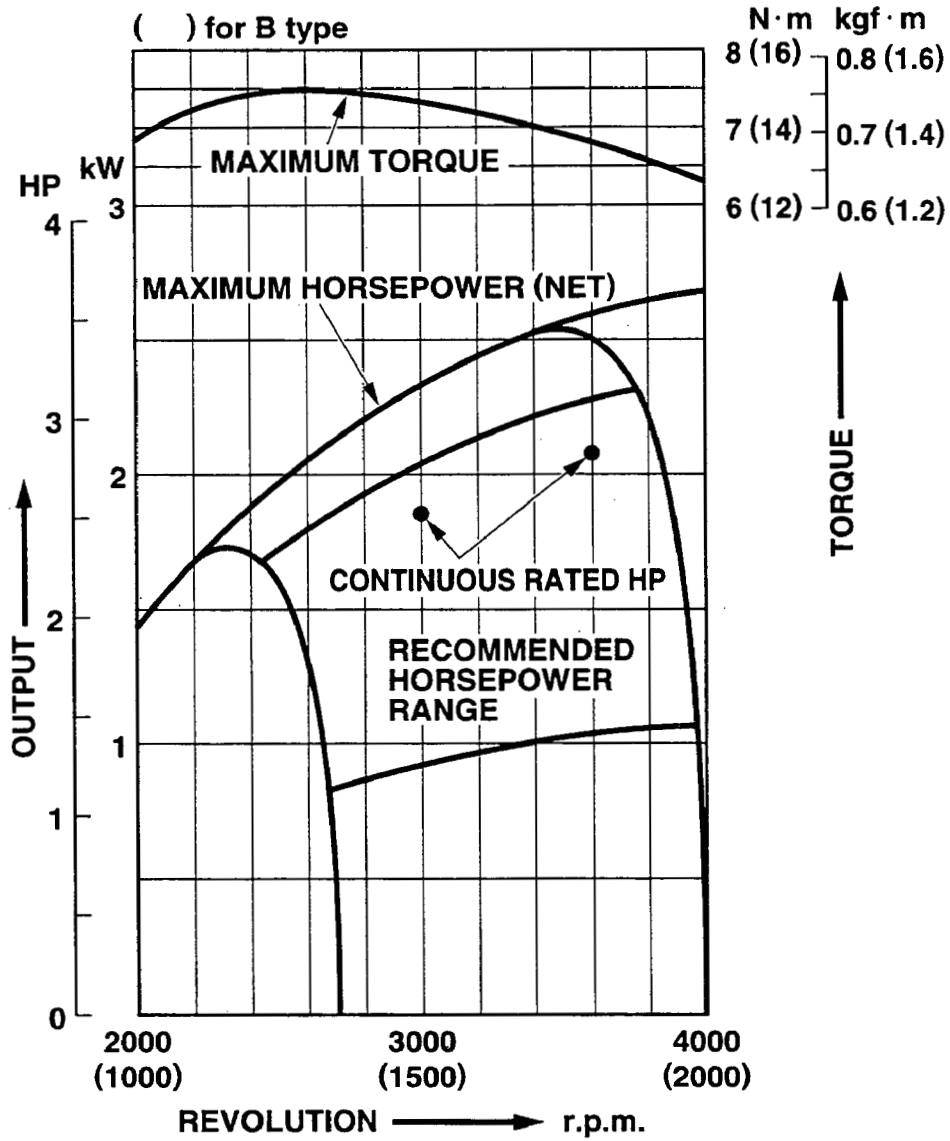

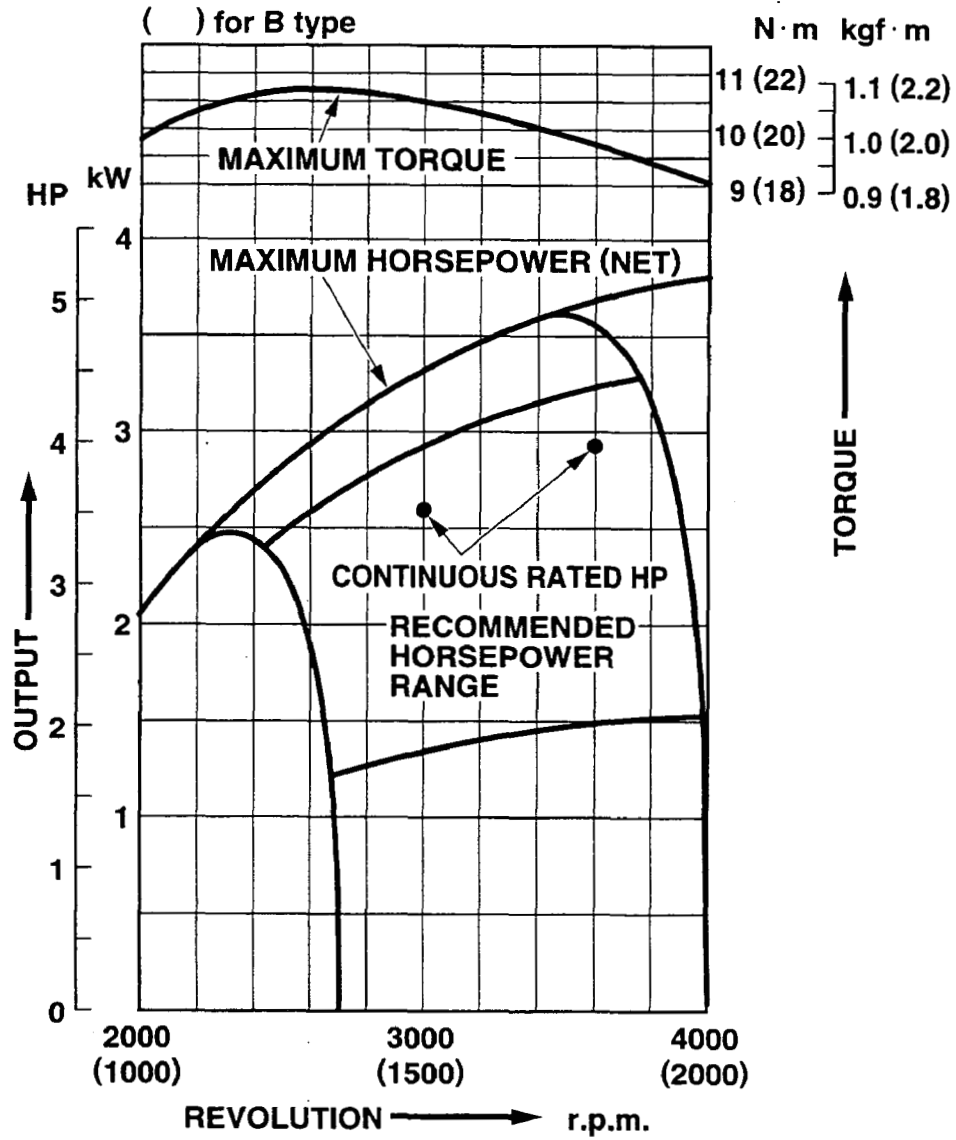

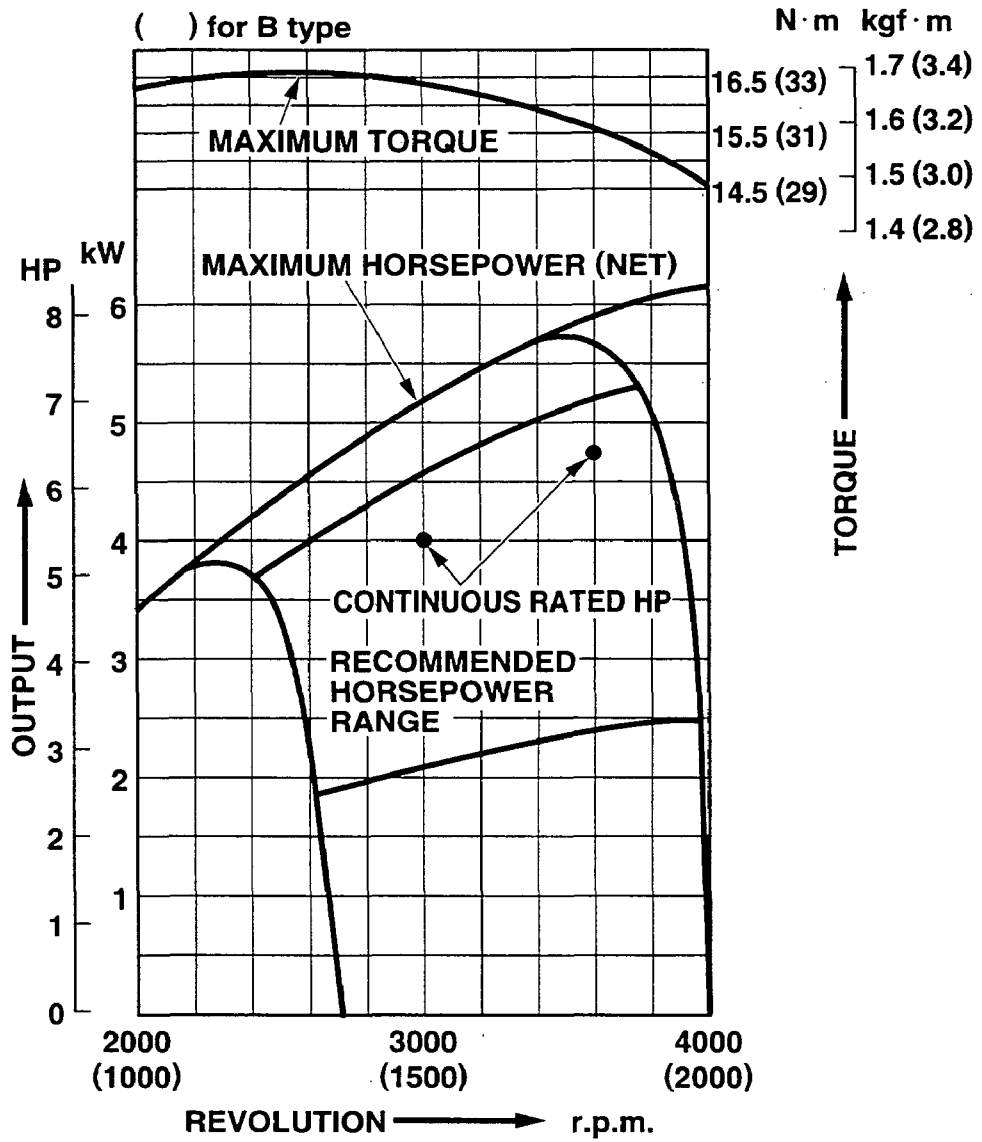

3. FEATURES

1. The overhead valve design offers a compactness, light weight and ideal combustion characteristics resulting in more power from less fuel and prolonged engine life.
2. An optimum lubrication and better tilted operation thanks to upright cylinder design.
3. A crossflow arrangement of intake and exhaust ports ensures stable performance under high ambient temperature.
4. The automatic decompression system lightens the recoil pull force by 40% comparing to the conventional SV engines.
5. An easy operation thanks to integrated engine control system. Improved throttle mechanism is adopted for easy starting.
6. Combustion and mechanical noises have been analyzed acoustically and improved for better tonal quality and lower engine noise.
7. Optimally designed reciprocating parts reduce the vibration level of the engine. EH25-2 engine equips single through-balancer shaft as an option.

4. GENERAL DESCRIPTION OF ENGINE COMPONENTS

4-1 CYLINDER AND CRANKCASE

The cylinder and crankcase is single piece aluminum diecasting. The cylinder liner, made of special cast iron, is molded into the aluminum casting.

The crankcase has a mounting surface on the output shaft side, where the main bearing cover is attached.

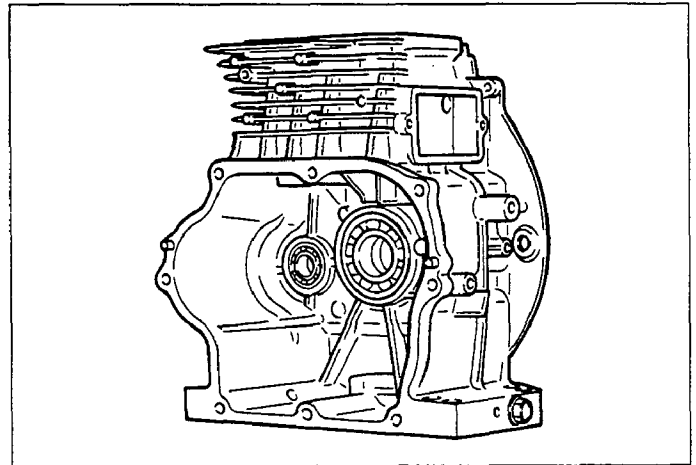

Fig. 4-1

4-2 MAIN BEARING COVER

The main bearing cover is an aluminum diecasting, which is mounted on the output shaft side of the crankcase.

Remove the main bearing cover to inspect the inside of the engine.

The pilots and bosses are machined on the cover for direct mounting of the engine onto such machines as generators and pumps.

Oil gauge (fillers) are on both sides of the cover for easy maintenance.

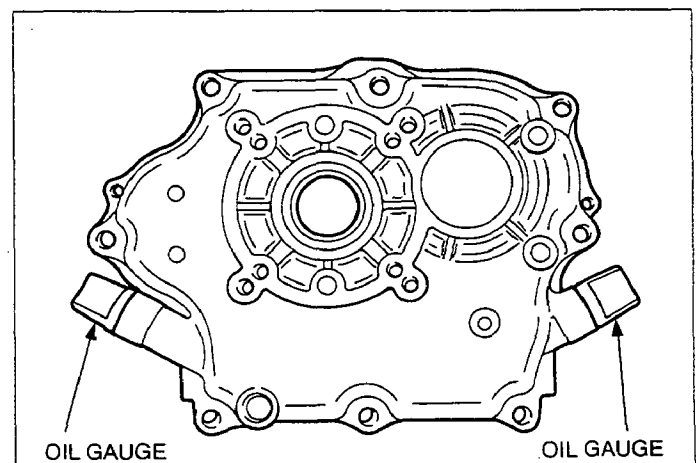

Fig. 4-2

4-3 CRANKSHAFT

The crankshaft is forged carbon steel, and the crank pin is induction-hardened.

The output end of the shaft has a crankshaft gear, and balancer gear for EH25-2 which are pressed into position.

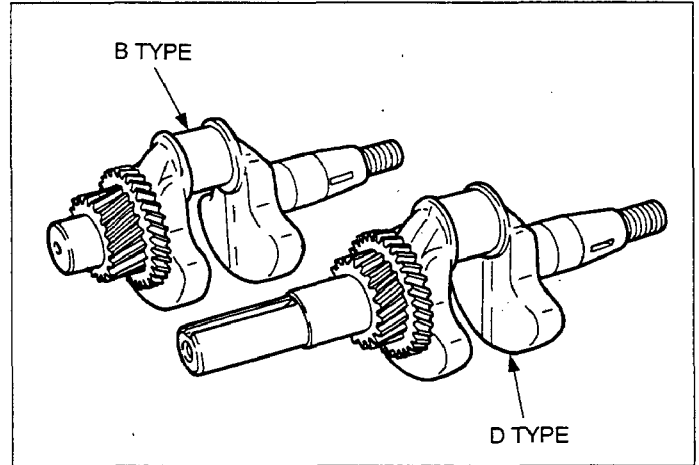

Fig. 4-3

4-4 CONNECTING ROD AND PISTON

The connecting rod is an aluminum alloy diecasting, and its large and small ends function as bearings. The piston is an aluminum alloy casting, and carries two compression rings and one oil ring.

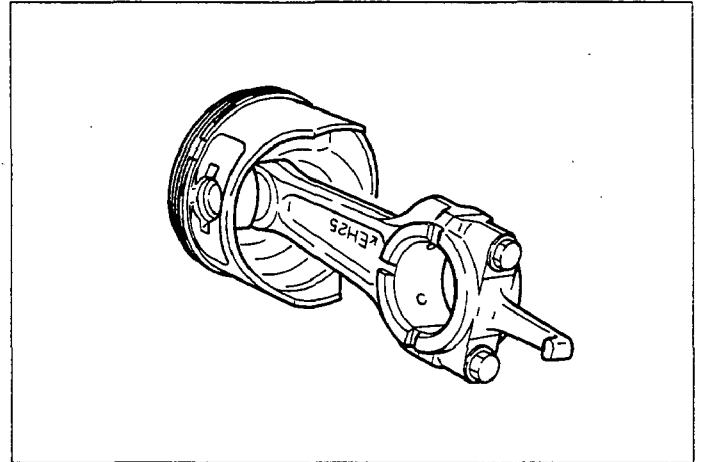

Fig. 4-4

4-5 PISTON RINGS

The piston rings are made of special cast iron. The profile of the top ring is barrel face and the second ring has a tapered face. The oil ring consists of a cutter ring and a coil expander for better sealing and less oil consumption.

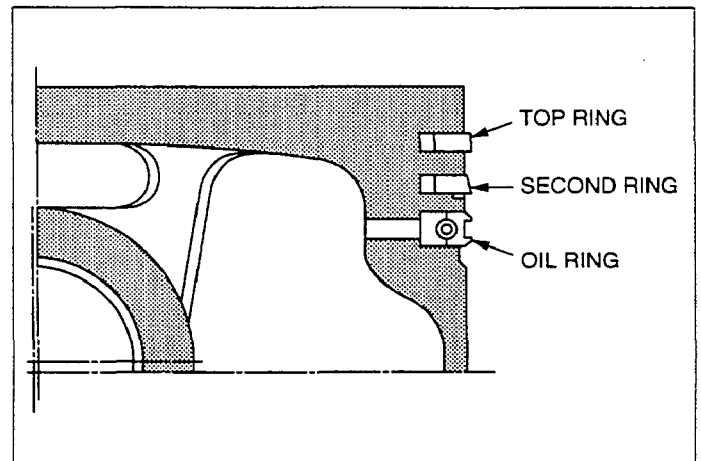

Fig. 4-5

4-6 CAMSHAFT

The camshaft for the D-type engine is made of special cast iron and camshaft gears are casted together in one piece.

Both sides of the shaft fit into the plane bearings on the crankcase and main bearing cover.

The camshaft for the B-type engine is made of forged carbon steel and also functions as PTO shaft.

The cam gear is press fitted on the shaft and the ball bearings are employed on both sides for supporting the shaft.

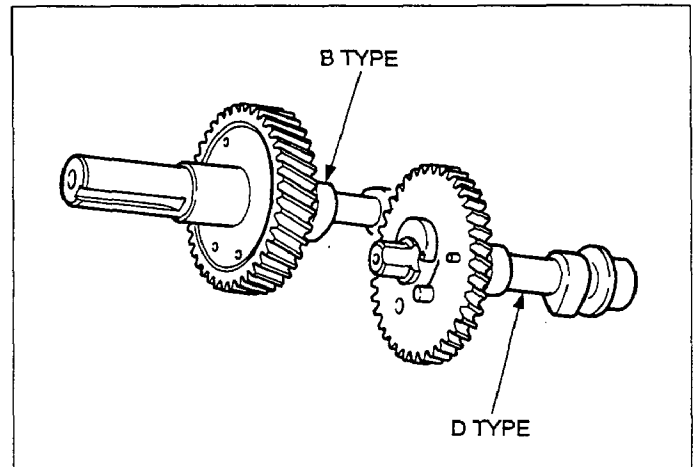

Fig. 4-6

4-7 VALVE ARRANGEMENT

The intake valve is located on flywheel side of the cylinder head.

The hard alloy valve seats are molded in the cylinder head and stellite is fused to the exhaust valve face.

The cylinder baffle leads cooling air to the exhaust valve area for the optimum cooling.

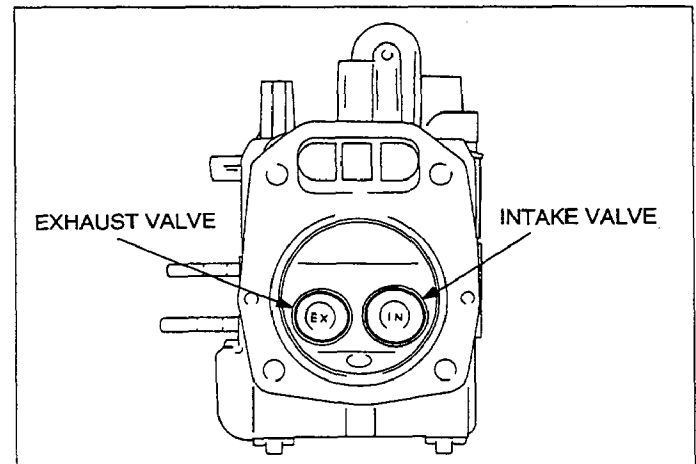

Fig. 4-7

4-8 CYLINDER HEAD

The cylinder head is an aluminum die casting which utilizes wedge type combustion chamber for the highest combustion efficiency.

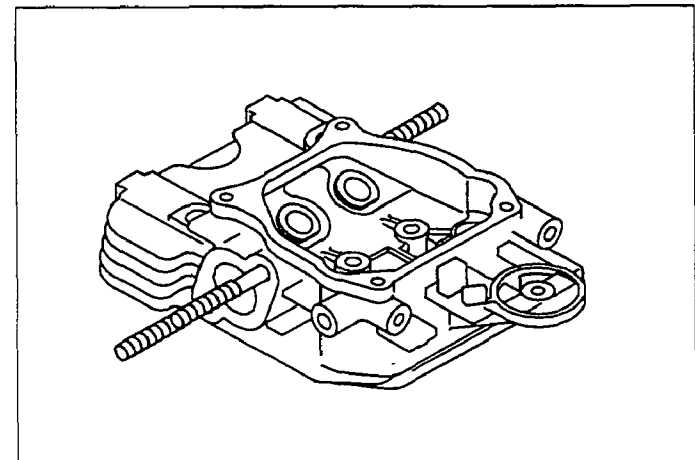

Fig. 4-8

4-9 GOVERNOR SYSTEM

The governor is a centrifugal flyweight type which ensures constant operation at the selected speed against load variations.

The governor gear with governor weights is installed on the main bearing cover.

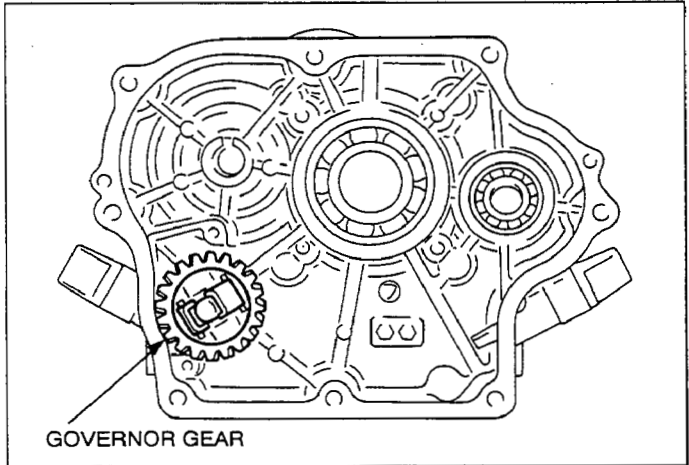

Fig. 4-9

4-10 COOLING SYSTEM

The large fins on the flywheel provide sufficient cooling air capacity for the inlet and exhaust area and cylinder.

The cylinder baffle helps the cooling air flow efficiently.

4-11 LUBRICATION

All the rotating and sliding parts are splash-lubricated by the oil scraper on the connecting rod.

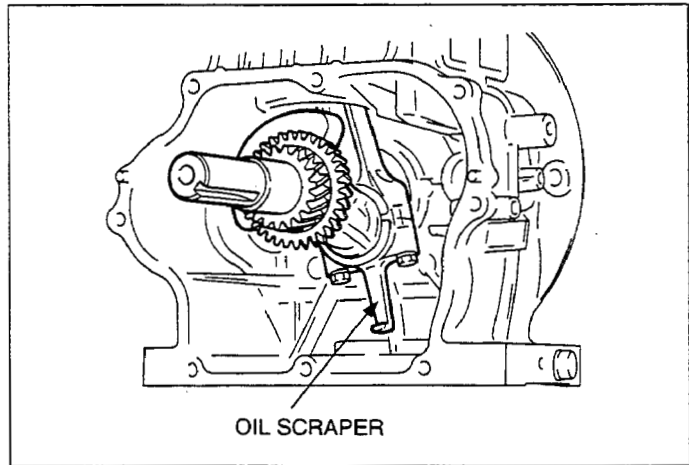

Fig. 4-10

4-12 IGNITION SYSTEM

The ignition system is a transistor controlled magneto ignition system which consists of a flywheel and an ignition coil with a built in transistor.

This system has an ignition timing advance for easy starting.

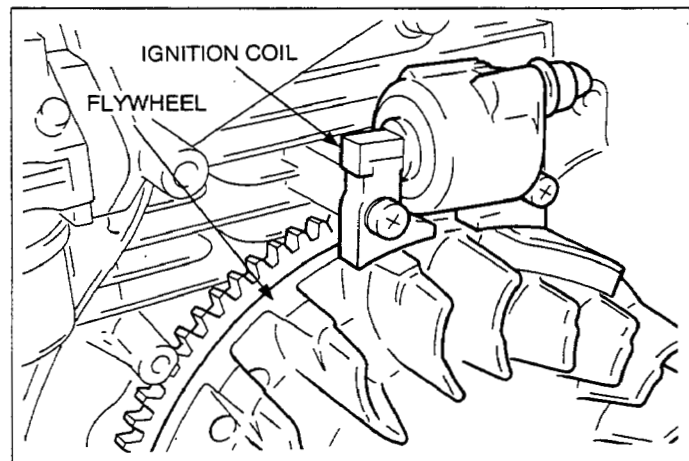

Fig. 4-11

4-13 CARBURETOR

The engines are equipped with a horizontal draft carburetor that has a float controlled fuel system and a fixed main jet.

The carburetors are calibrated carefully for easy starting, good acceleration, low fuel consumption and sufficient output.

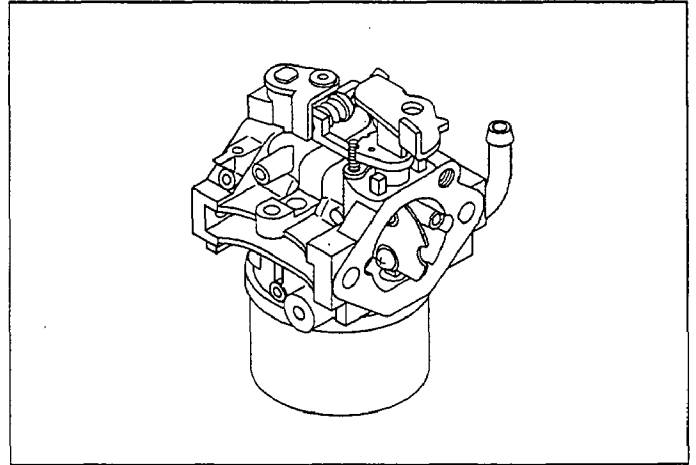

Fig. 4-12

4-14 AIR CLEANER

The air cleaner is a single urethane foam element system. As an option, heavy duty type with a double element type is available.

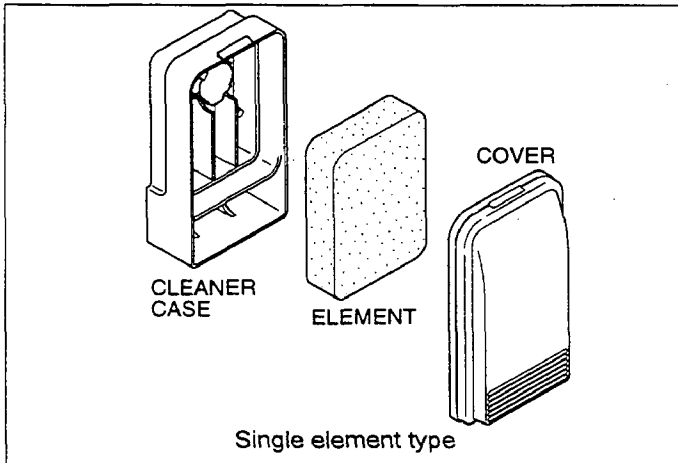

Fig. 4-13-1

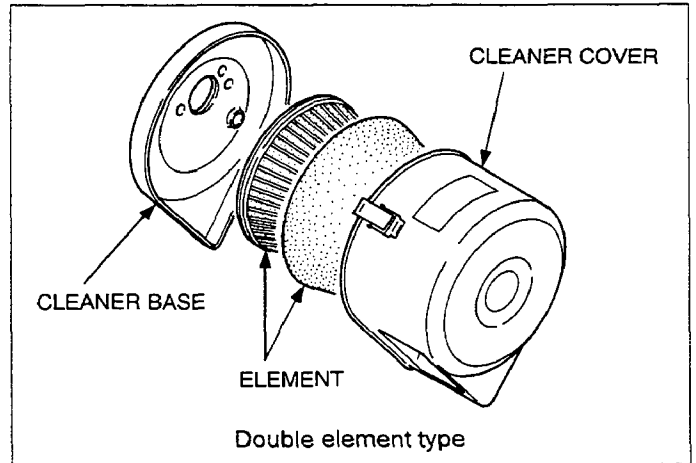

Fig. 4-13-2

4-15 BALANCER (Option for EH25-2)

Unbalanced inertia force is balanced by the balancer which rotates at the same speed with the crankshaft to effectively reduce vibration.

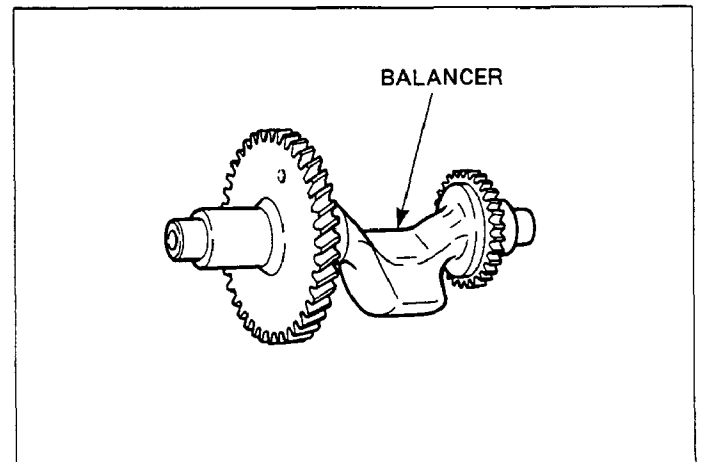

Fig. 4-14

4-16 DECOMPRESSION SYSTEM

An automatic decompression mechanism which opens exhaust valve before the piston reaches compression top is assembled on the camshaft for easy starting.

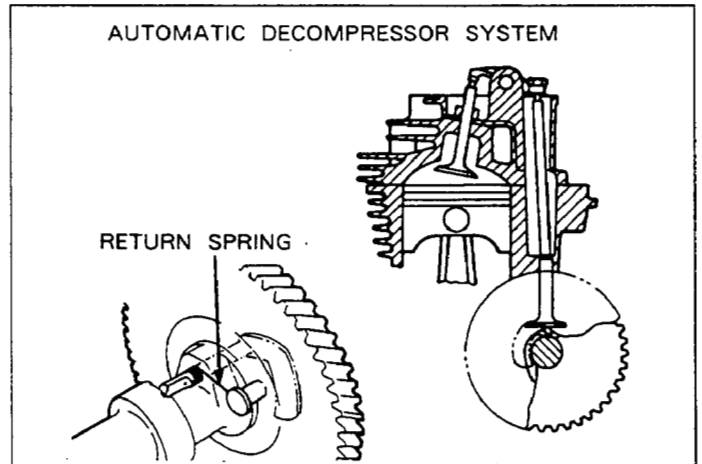
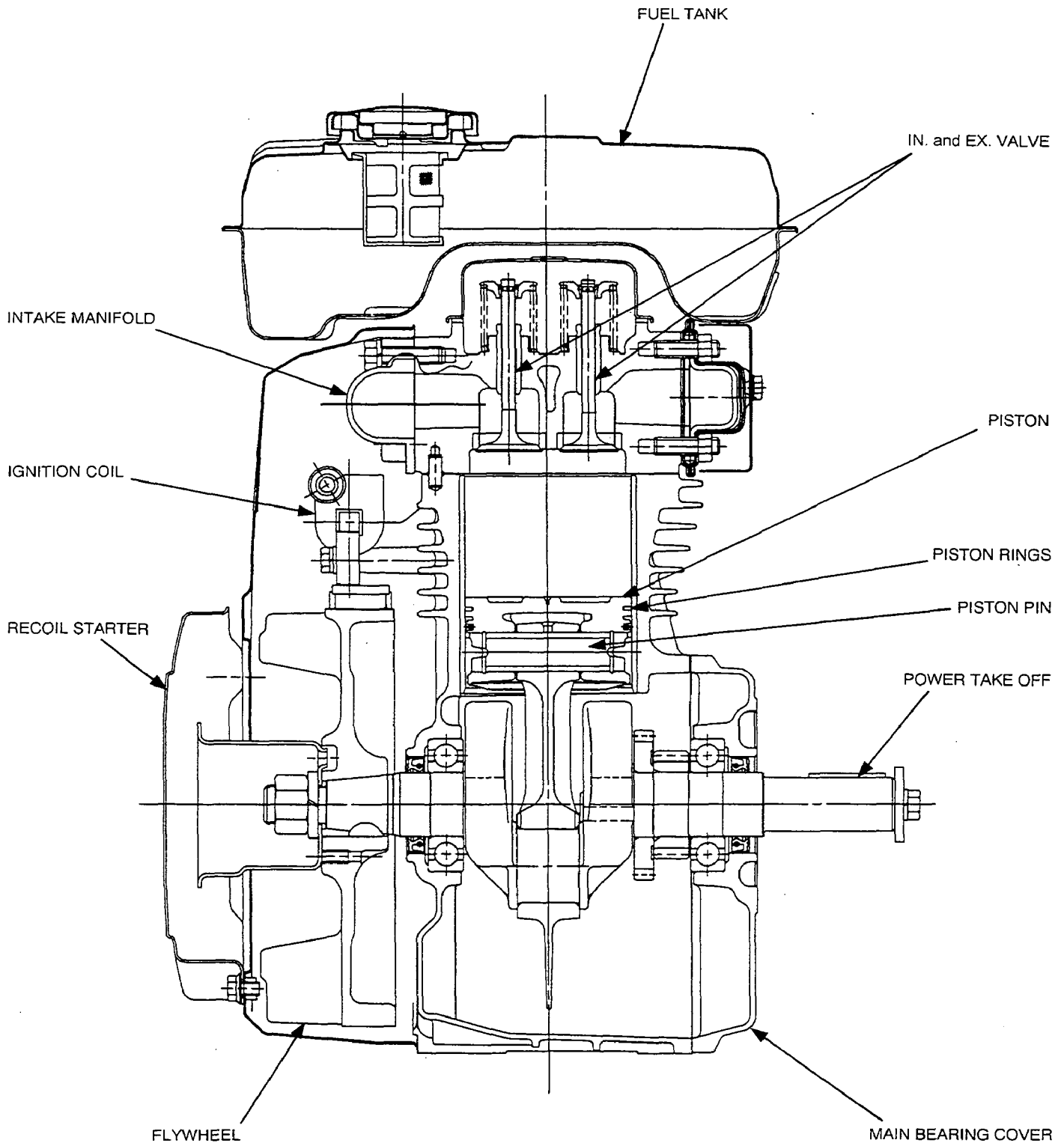
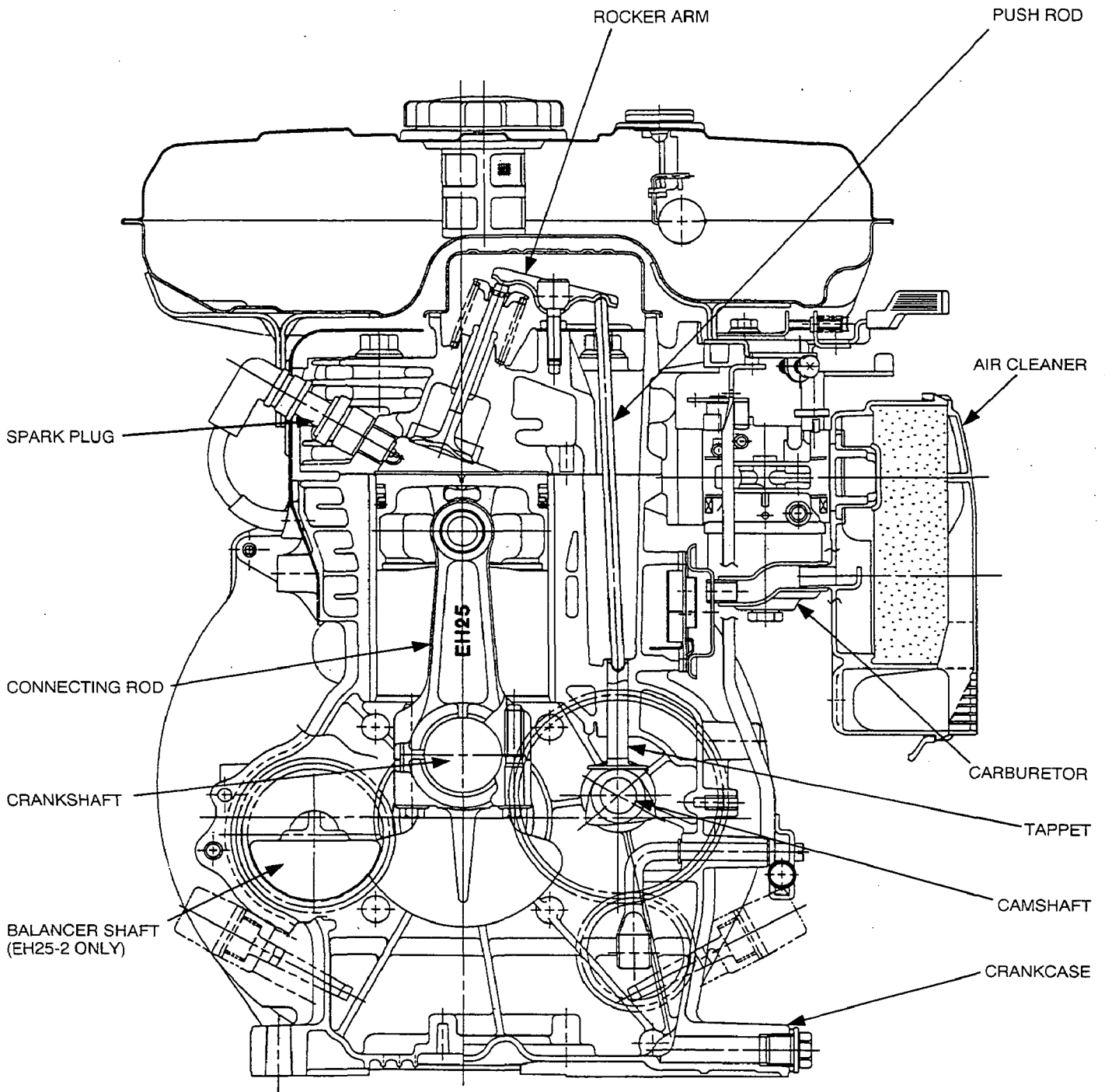

Fig. 4-14

4-17 SECTIONAL VIEW OF ENGINE





5. DISASSEMBLY AND REASSEMBLY

5-1 PREPARATIONS AND SUGGESTIONS

- 1) When disassembling the engine, memorize the locations of individual parts so that they can be reassembled correctly. If you are uncertain of identifying some parts, it is suggested that tags be attached to them.
- 2) Have boxes ready to keep disassembled parts by group.
- 3) To prevent losing and misplacing, temporarily assemble each group of disassembled parts.
- 4) Carefully handle disassembled parts, and clean them with washing oil if necessary.
- 5) Use the correct tools in the correct way.

5-2 SPECIAL TOOLS

Tool No.	Tool	Use
209-95004-07	Flywheel puller with bolt	For pulling off the flywheel EH25-2
Market parts	Flywheel puller	For pulling off the flywheel EH12-2, EH17-2

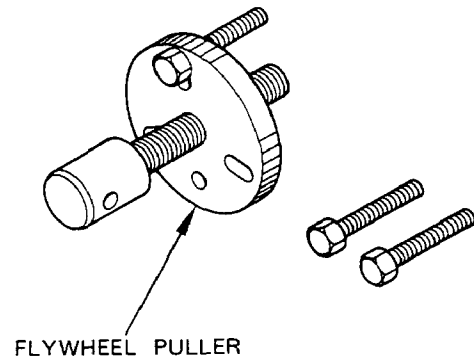
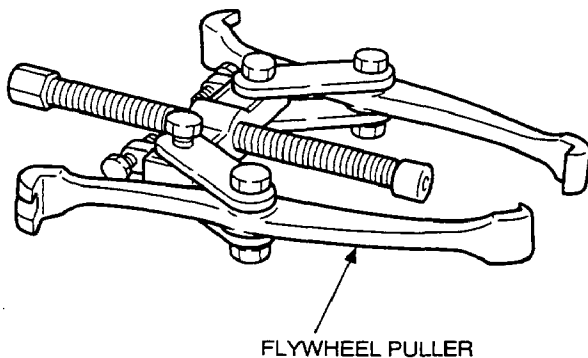

Fig. 5-1

5-3 DISASSEMBLY PROCEDURES

Step	Part to remove	Procedures	Remarks	Tool
1	Oil drain	(1) Remove oil drain plug and drain oil. (2) To discharge oil quickly, remove oil gauge.	Be careful not to lose the gasket.	14mm box wrench

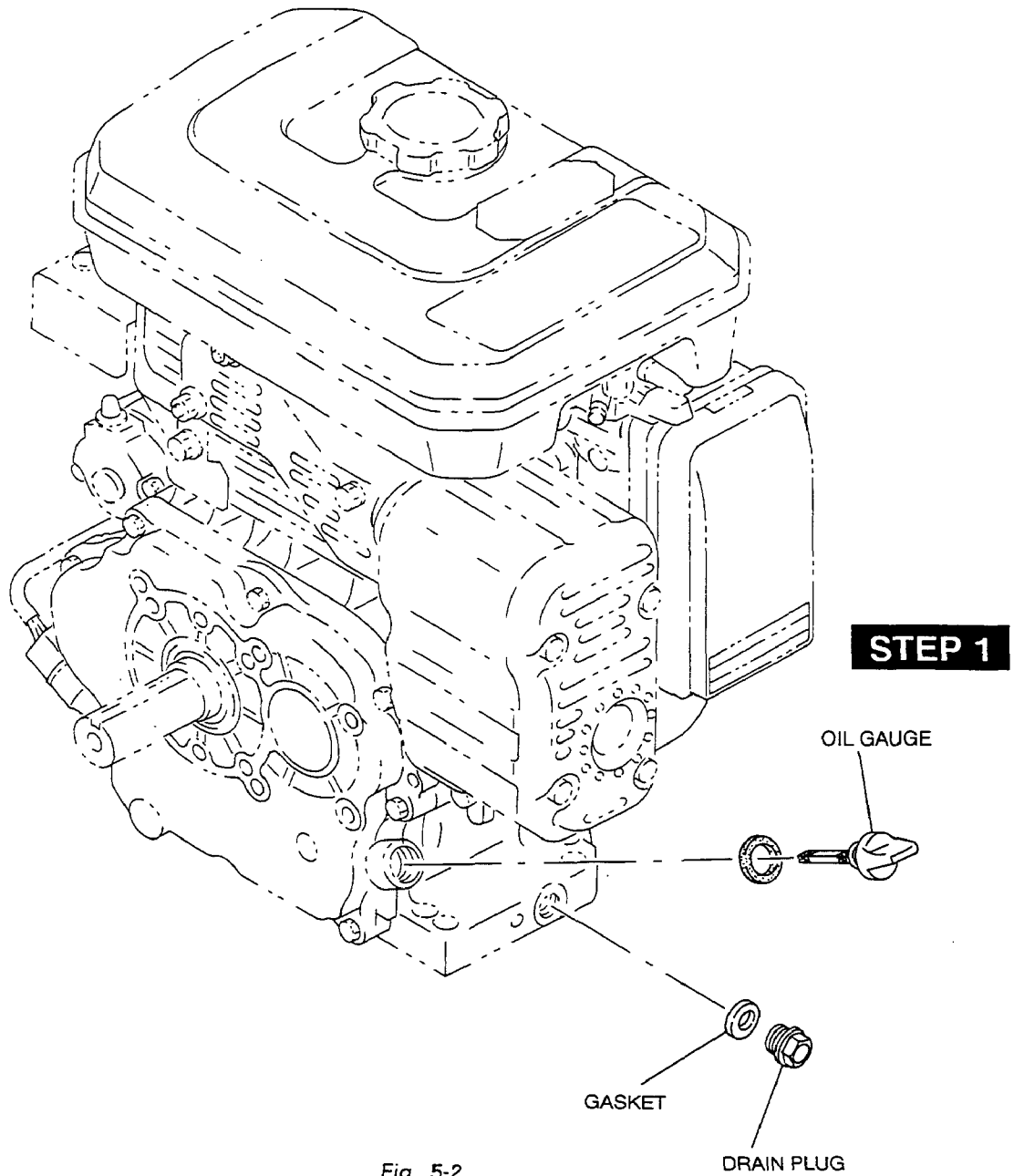

Fig. 5-2

Step	Part to remove	Procedures	Remarks	Tool
2	Fuel tank	(1) Close fuel valve. (2) Disconnect fuel hose between fuel strainer and carburetor. (3) Remove fuel tank from cylinder head. M6×14mm bolt ···· 4pcs. (EH12-2,17-2) M8×20mm bolt ···· 4pcs. (EH25-2)	Wipe off spilt fuel thoroughly.	10mm (12mm) socket wrench

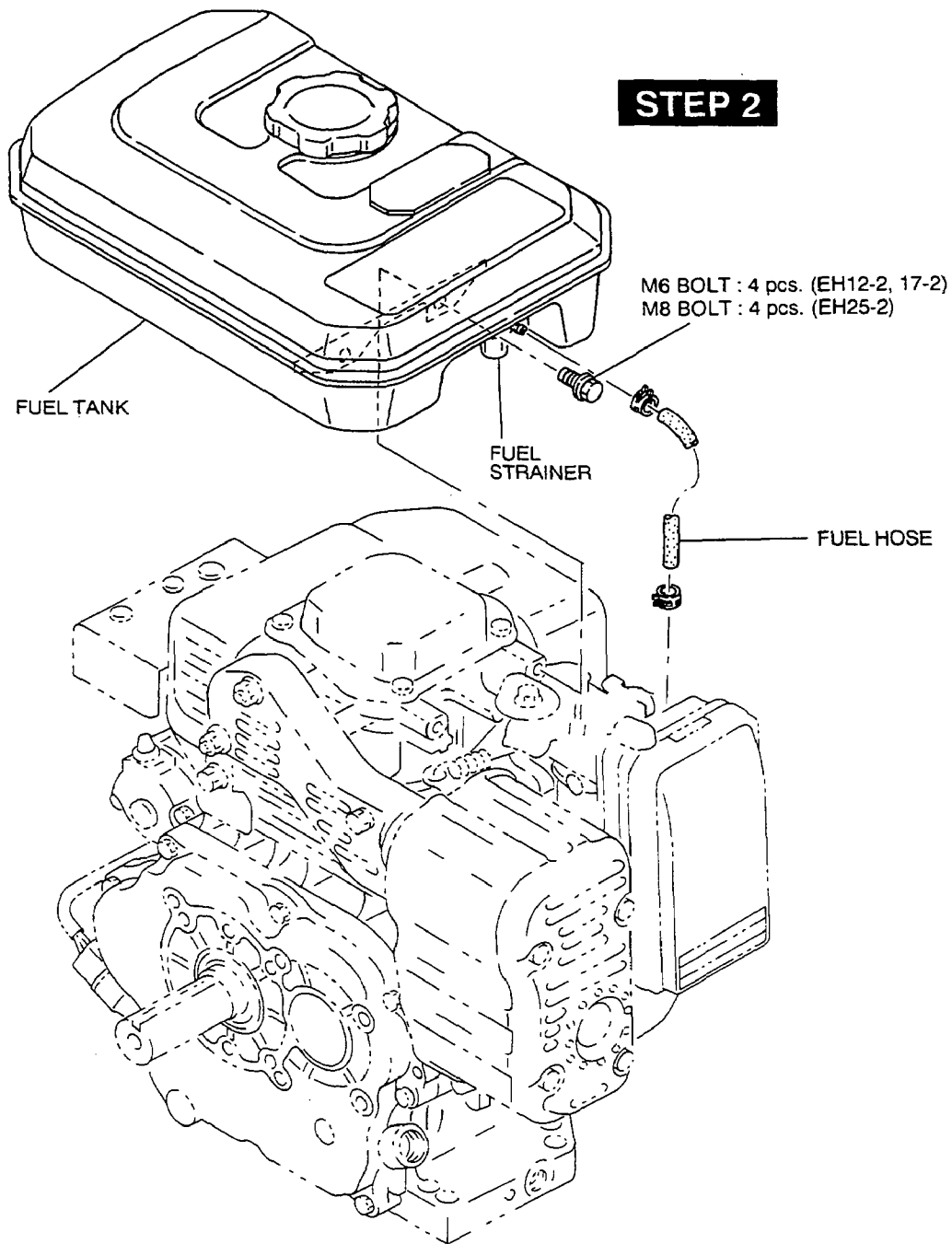

Fig. 5-3

Step	Part to remove	Procedures	Remarks	Tool
3	Recoil starter	(1) Remove recoil from blower housing. M6×8mm flange bolt •••• 4pcs.		10mm box wrench
4	Blower housing	(1) Remove blower housing from crankcase. M6×12mm flange bolt •••• 4pcs.		10mm box wrench
5	Oil sensor (Option)	(1) Remove oil sensor probe. Be careful not to damage stick and sensor since these are sensitive and an erratic operation may result.		

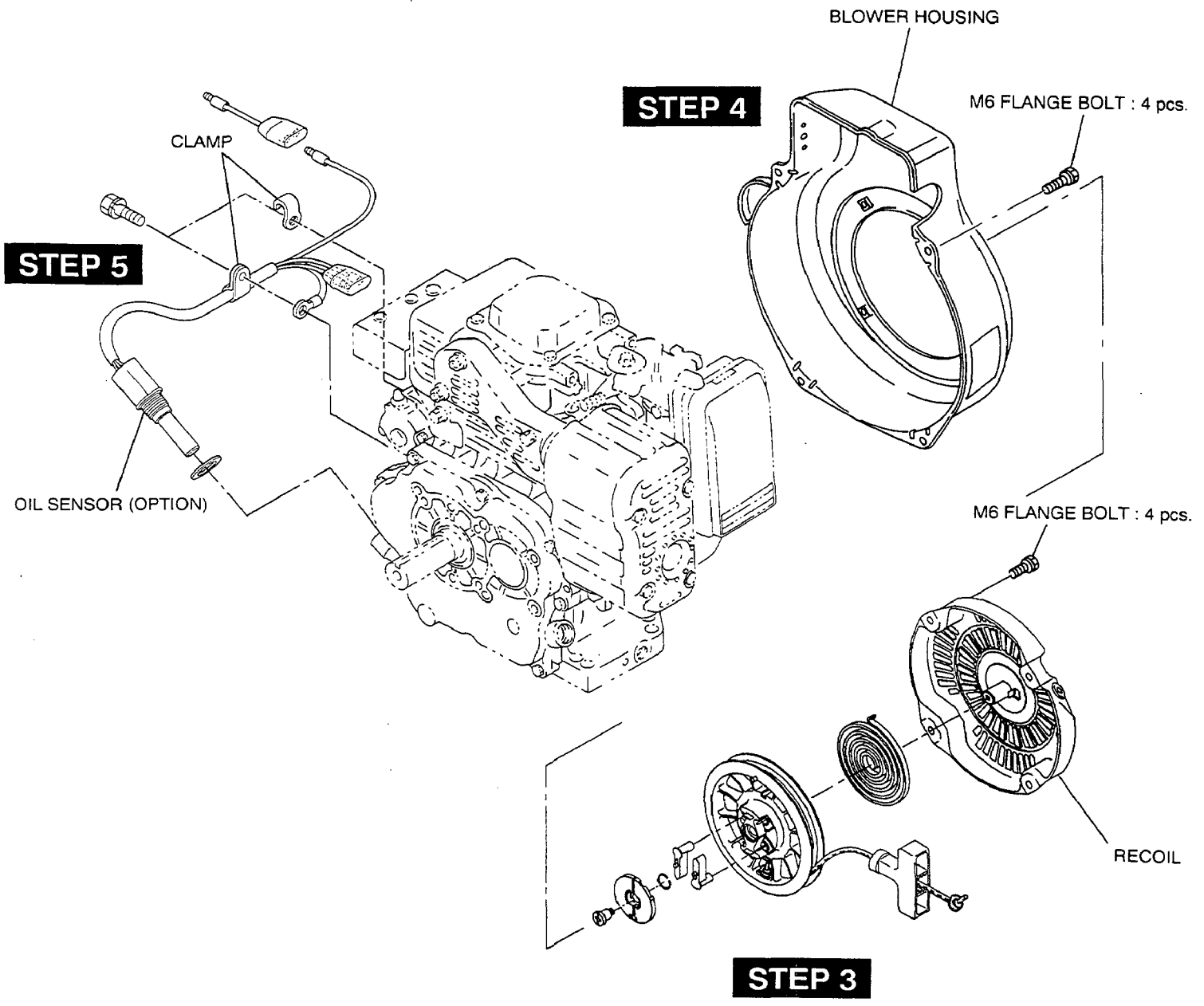

Fig. 5-4

Step	Part to remove	Procedures	Remarks	Tool
6	Muffler cover, Muffler and Exhaust pipe cover	(1) Remove muffler cover and exhaust pipe cover. M6×10mm flange bolt 5pcs. (2) Remove muffler from crankcase and cylinder head. M8 nut 2pcs. M6×12mm flange bolt 1pc. (EH12-2,17-2) M8×16mm flange bolt 1pc. (EH25-2)	Be careful not to lose muffler gasket.	8mm, 10mm and 12mm socket wrench

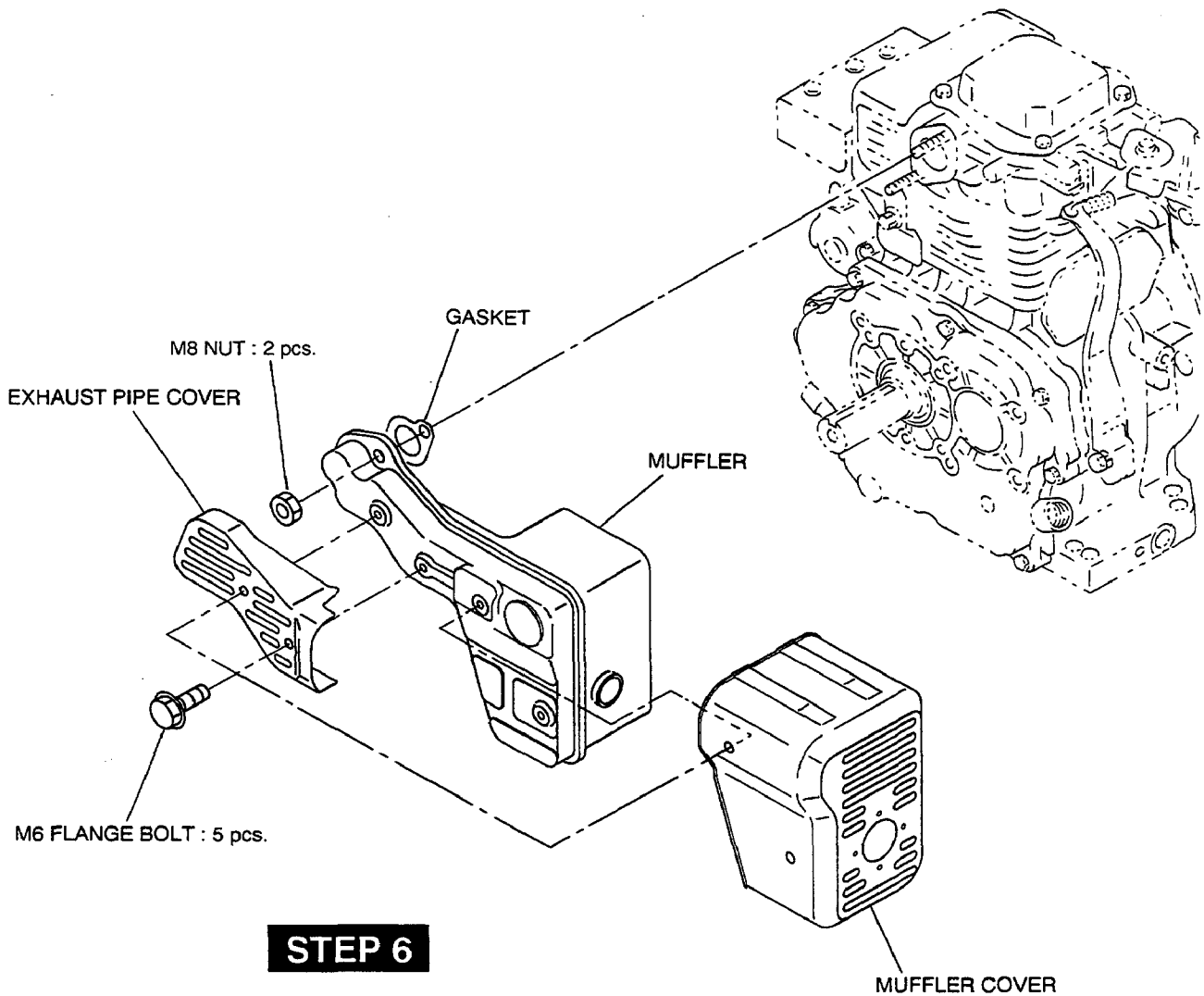

Fig. 5-5

Step	Part to remove	Procedures	Remarks	Tool
7	Control box and Electric starter (Option)	(1) Disconnect wires. blue •••• 1 (diode rectifier) light blue •••• 1 (diode rectifier) black •••• 1 (magnetic switch) (2) Remove black wires from electric starter. (3) Remove control box. (4) Loosen two bolts and remove electric starter. M8 bolt •••• 2pcs.	Fastened together with fuel tank.	12mm socket wrench

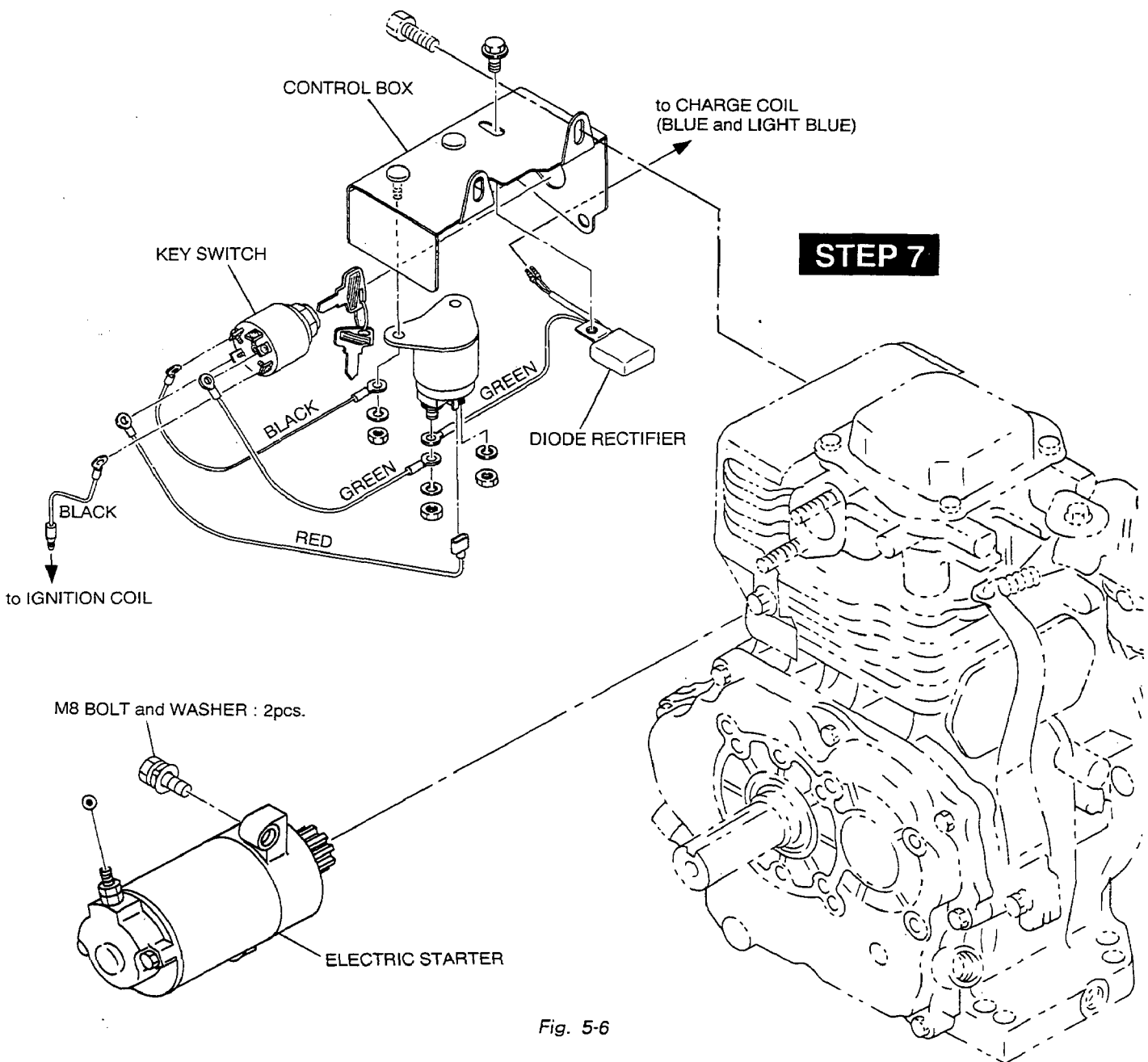

Fig. 5-6

Step	Part to remove	Procedures	Remarks	Tool
8	Head cover	(1) Remove head cover from crankcase. M6×12mm flange bolt 1 pc.		10mm socket wrench
9	Air cleaner	(1) Remove cleaner cover and cleaner element. (2) Remove cleaner case. M6 flange nut 2 pcs.	Fastened together with carburetor.	10mm socket wrench

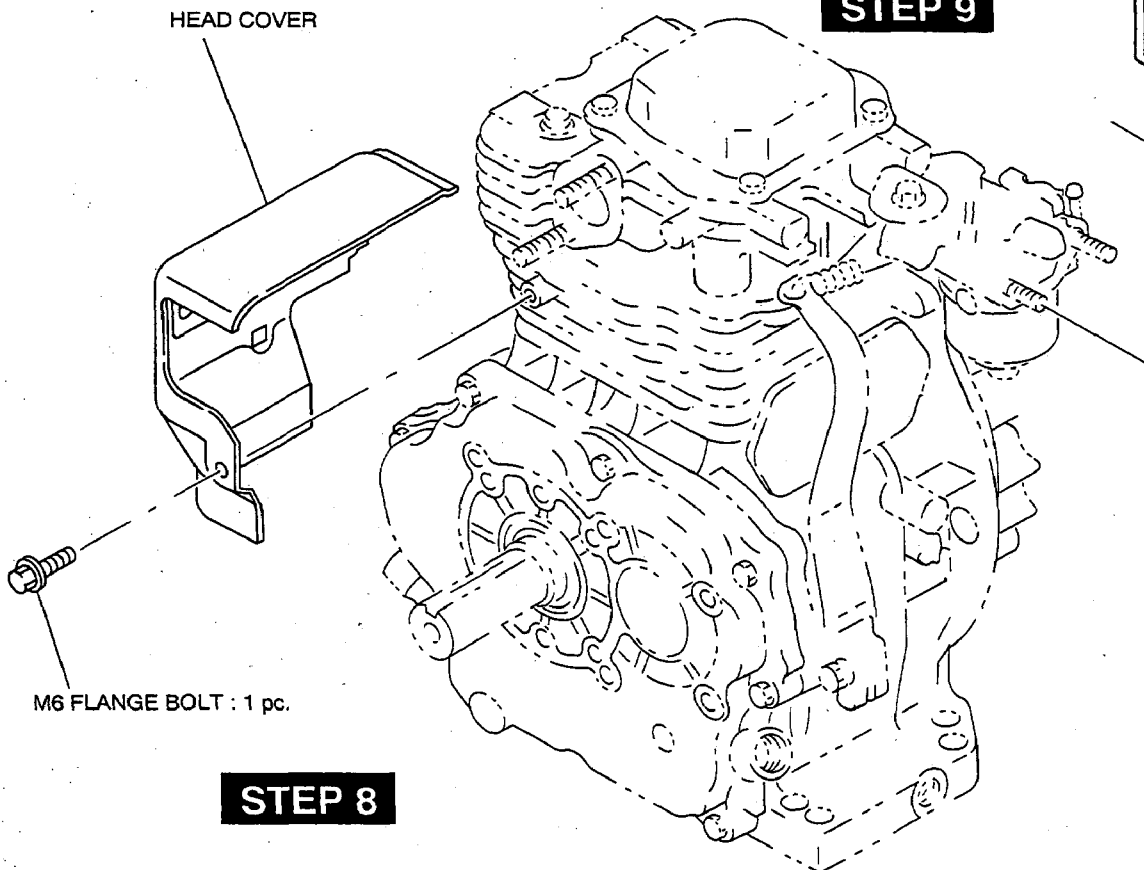
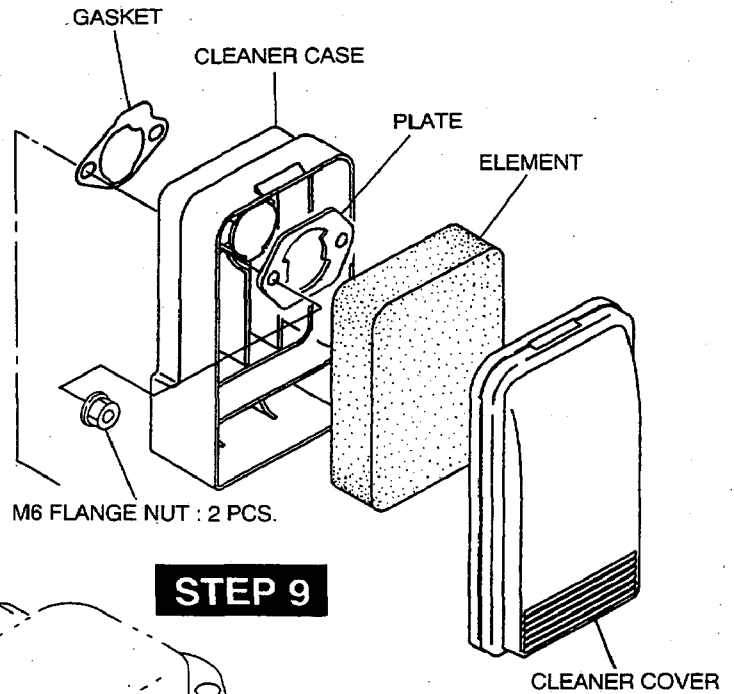

Fig. 5-7

Step	Part to remove	Procedures	Remarks	Tool
10	Governor lever, Governor rod and Governor spring	(1) Unhook governor spring from speed control lever. (2) Remove governor lever from governor shaft. M6×30mm bolt and washer 1pc. (3) Detach governor lever, governor rod and rod spring from carburetor.	Bolt and washer on governor lever only needs to be loosened.	10mm socket wrench
11	Carburetor	(1) Remove carburetor from intake pipe.		
12	Speed control lever	(1) Remove stop plate, friction plate and speed control lever. M6×14mm flange bolt 1pc.		10mm socket wrench
13	Intake pipe	(1) Remove intake pipe from cylinder head. M6 flange nut 2pcs. (EH12-2,17-2) M6×25mm flange bolt 1pc. (EH12-2, 17-2) M8×28mm bolt and washer 3pcs. (EH25-2)	Be careful not to lose insulator and gasket.	10mm, 12mm socket wrench

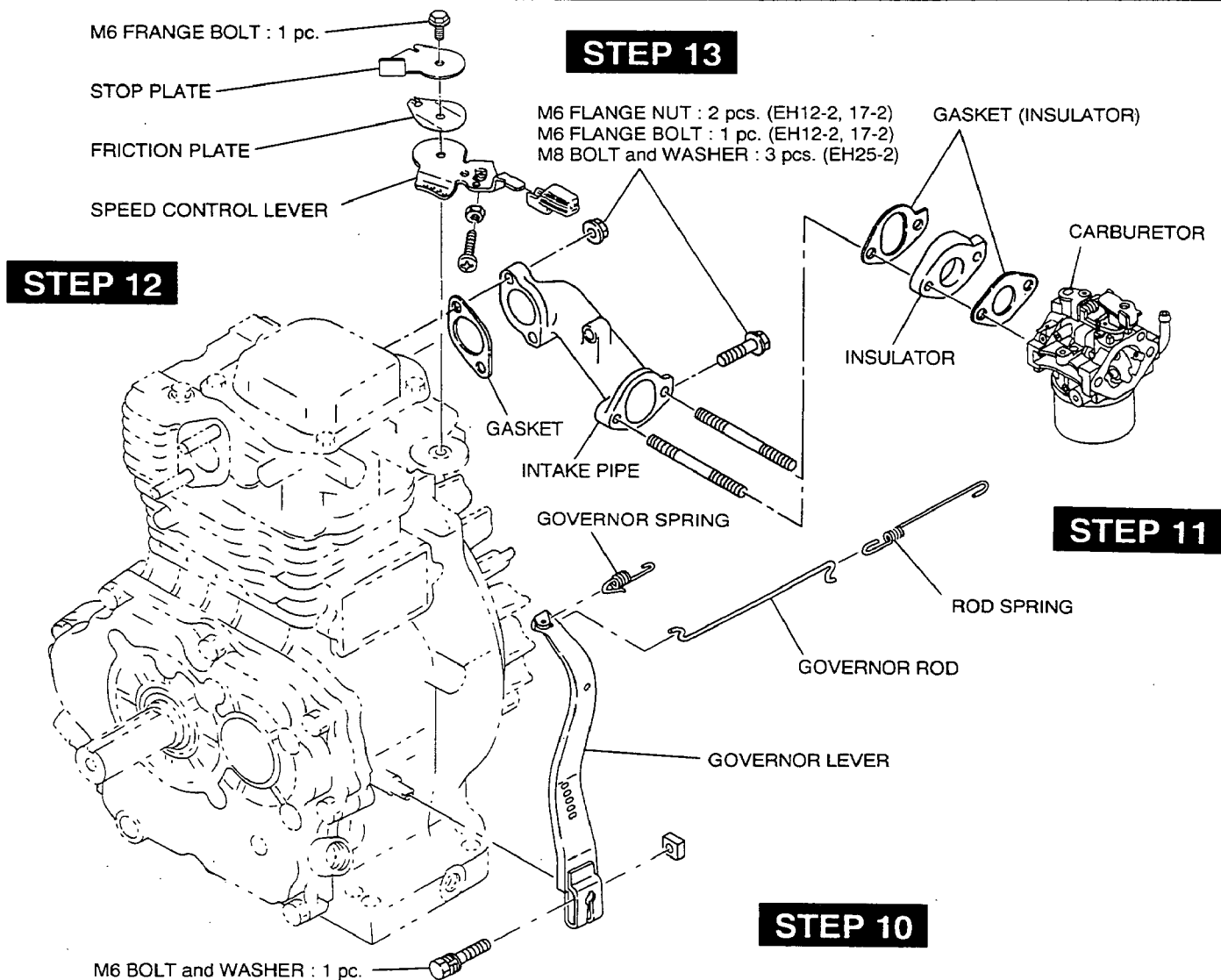

Fig. 5-8

Step	Part to remove	Procedures	Remarks	Tool
14	Ignition coil	(1) Disconnect ignition plug cap and remove ignition coil from crankcase. M6×25mm bolt and washer •••• 2pcs.		10mm socket wrench
15	Starter pulley	(1) Remove starter pulley from flywheel. Place socket wrench on flywheel fastening nut and strike tip of the lever with hammer. Refer to the illustration below. (See Fig. 5-9.) 14mm nut •••• 1pc. (EH12-2, 17-2) 18mm nut •••• 1pc. (EH25-2)	Do not place bar or screw driver in flywheel fin to loosen flywheel nut.	19mm(EH12-2,17-2) 24mm(EH25-2) socket wrench

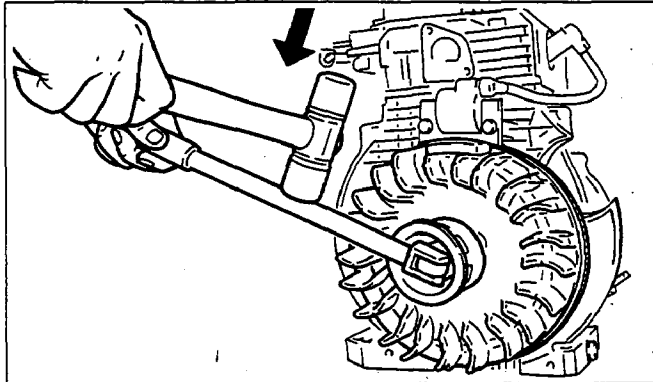
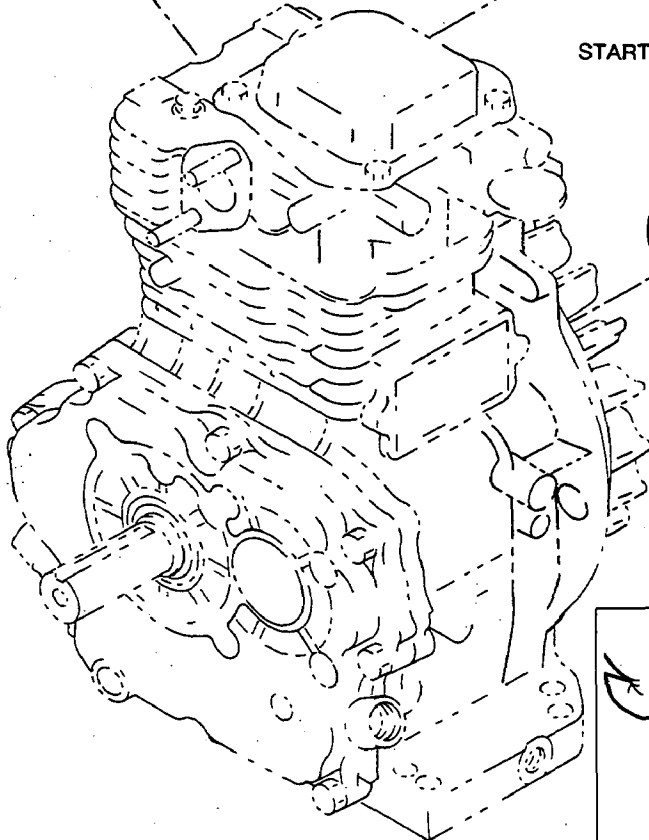
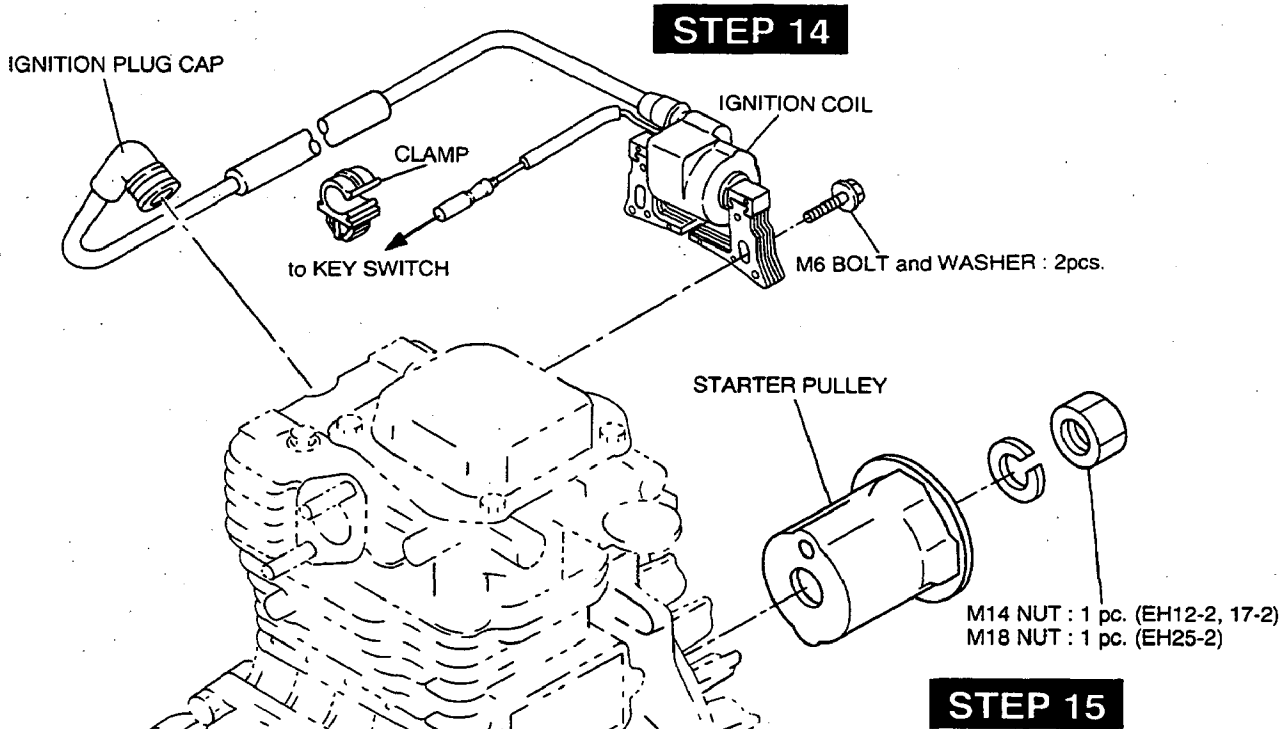

Fig. 5-10

Fig. 5-9

Step	Part to remove	Procedures	Remarks	Tool
16	Flywheel	(1) Remove flywheel from crankshaft. (2) Remove key from crankshaft. (See Fig. 5-12.)	Use flywheel puller as illustrated below. (See Fig. 5-11.)	Flywheel puller
17	Charge coil (Option)	(1) Remove charge coil. M6×25mm Screw •••• 2pcs.		
18	Spark plug	(1) Remove spark plug from cylinder head.		21mm socket wrench

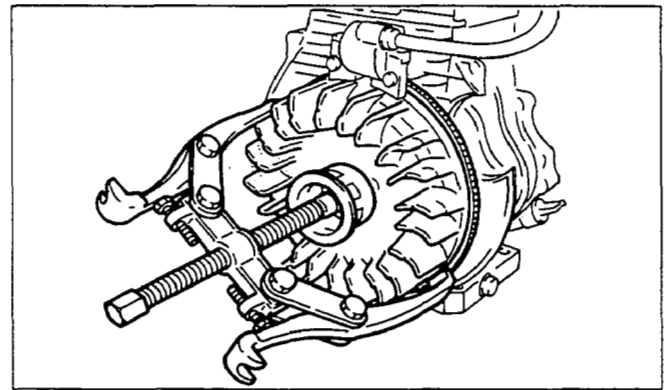

Fig. 5-11

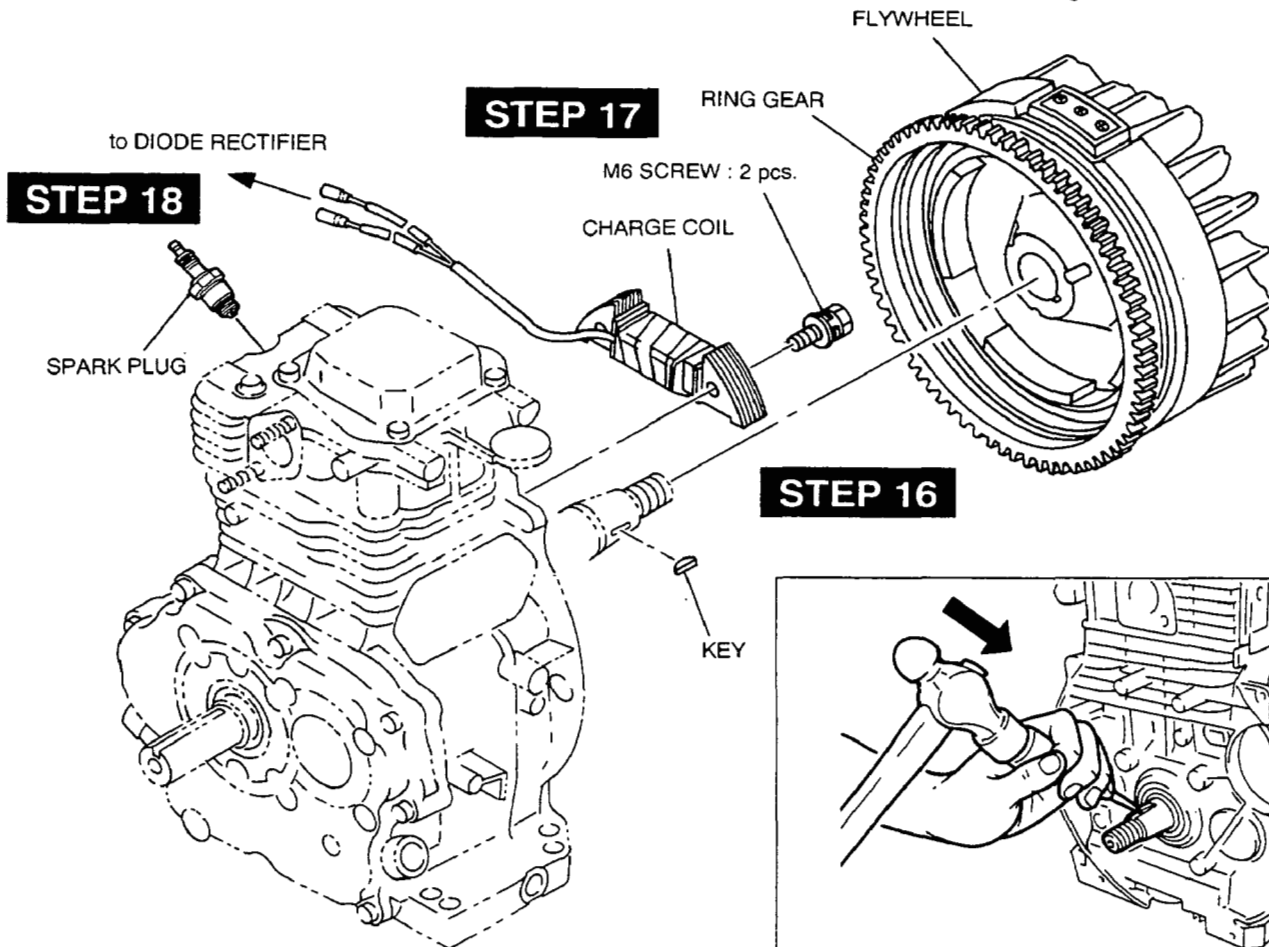

Fig. 5-13

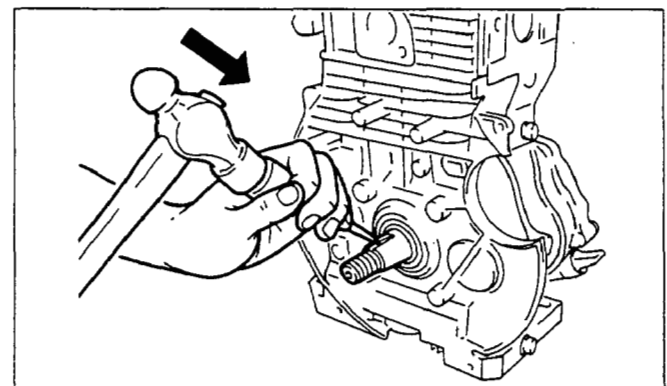

Fig. 5-12

Step	Part to remove	Procedures	Remarks	Tool
19	Rocker cover	(1) Remove rocker cover from cylinder head. M6×12mm flange bolt •••• 4pcs. (2) Remove gasket. (rocker cover)		10mm socket wrench
20	Cylinder head	(1) Remove cylinder head from crankcase. M8×65mm flange bolt •••• 4pcs. (EH12-2, 17-2) M10×75mm flange bolt •••• 4pcs. (EH25-2) (2) Detach cylinder head gasket from cylinder head. (3) Remove push rods.		12mm, 14mm socket wrench

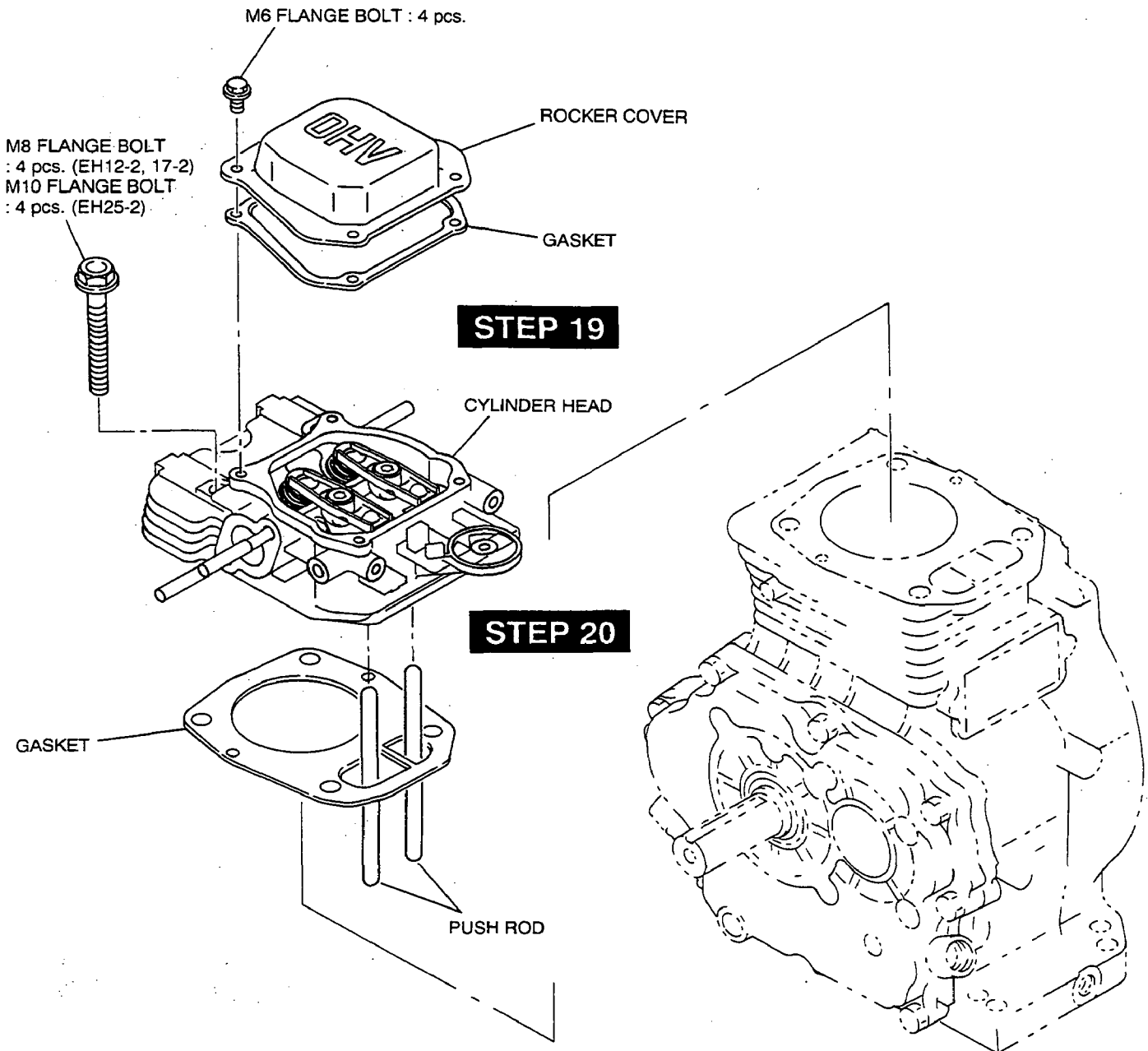

Fig. 5-14

Step	Part to remove	Procedures	Remarks	Tool
22	Cam shaft and Balancer shaft (Option for EH25-2)	(1) Remove cam shaft from crankcase. (2) Remove balancer shaft. (Option for EH25-2)	To prevent tappets from getting damaged, put the crankcase upside down. (See Fig. 5-17.)	
23	Tappet	(1) Remove tappets from crankcase.	Put a tag on tappets to identify intake and exhaust.	

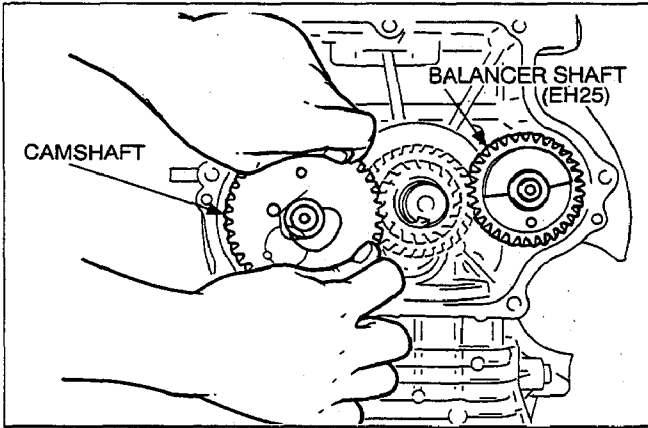

Fig. 5-17

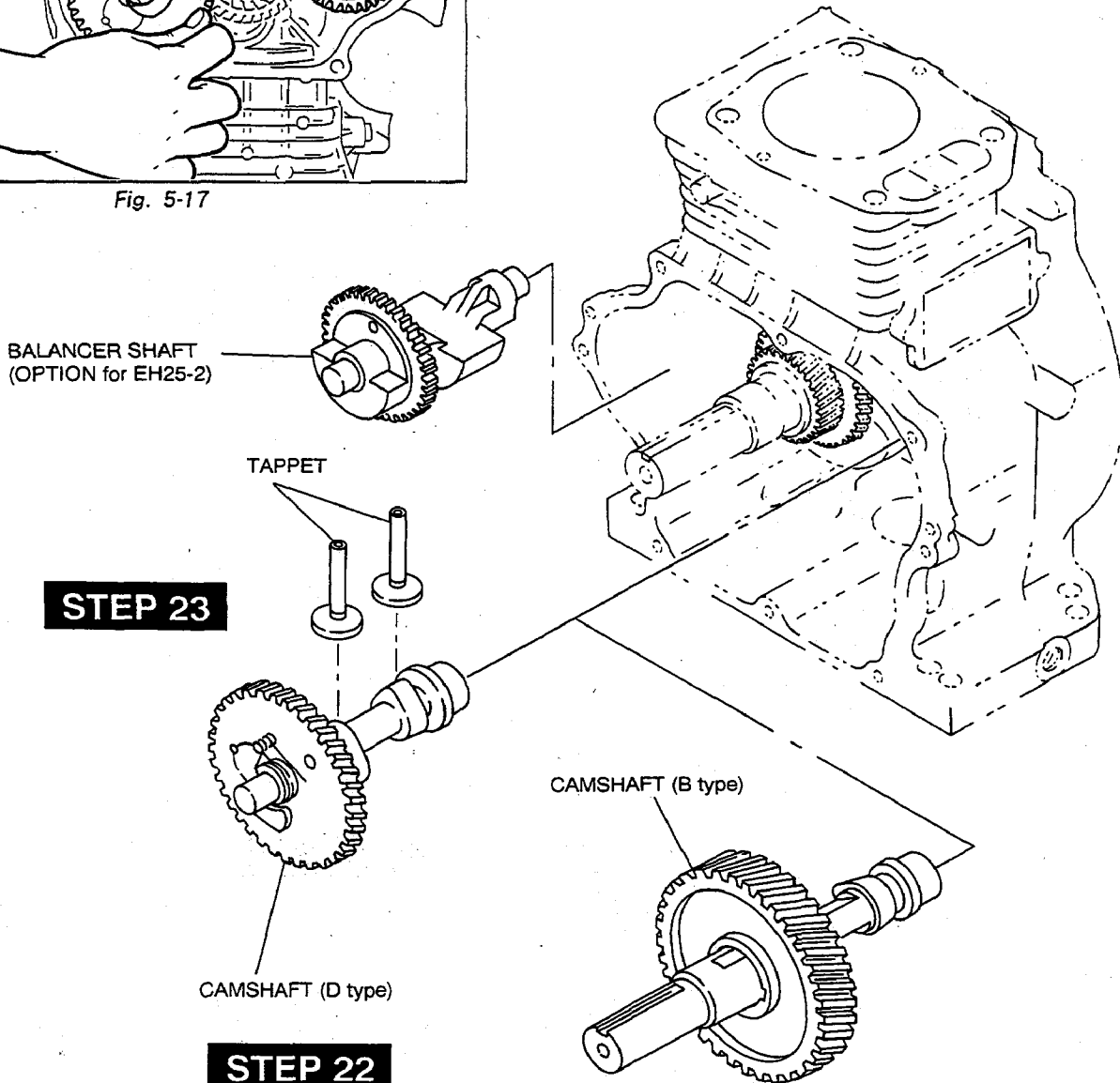

Fig. 5-18

Step	Part to remove	Procedures	Remarks	Tool
24	Connecting rod and Piston	(1) Remove connecting rod bolt after scraping off carbon from cylinder and piston. M6×34mm flange bolt ∙∙ 2pcs. (EH12-2) M7×37mm flange bolt ∙∙ 2pcs. (EH17-2) M8×46mm flange bolt ∙∙ 2pcs. (EH25-2) (2) Remove connecting rod cap. (3) Remove connecting rod from upper side of crankcase after rotating crankshaft so that piston comes up to top dead center.		10mm socket wrench
25	Piston and Piston rings	(1) Remove clips and piston pin. (2) Remove piston from connecting rod. (3) Remove piston rings from piston.	Do not damage the smaller end of connecting rod. Do not expand or twist piston rings.	

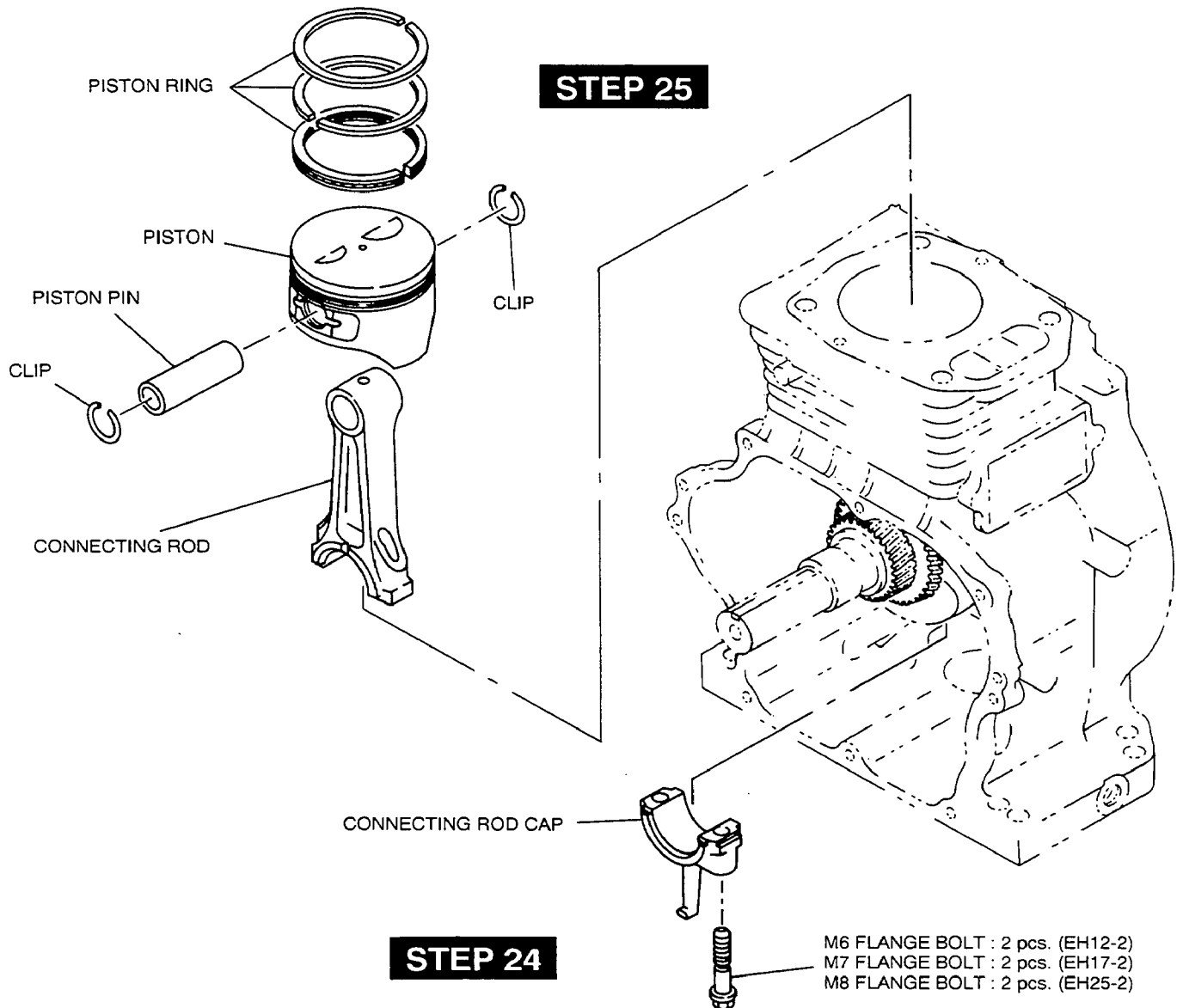

Fig. 5-19

Step	Part to remove	Procedures	Remarks	Tool
26	Crankshaft	(1) Remove crankshaft tapping at the flywheel end.	Be careful not to damage oil seal.	

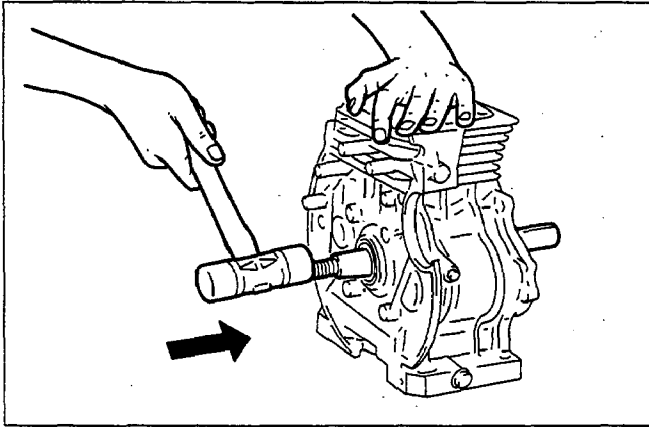

Fig. 5-20

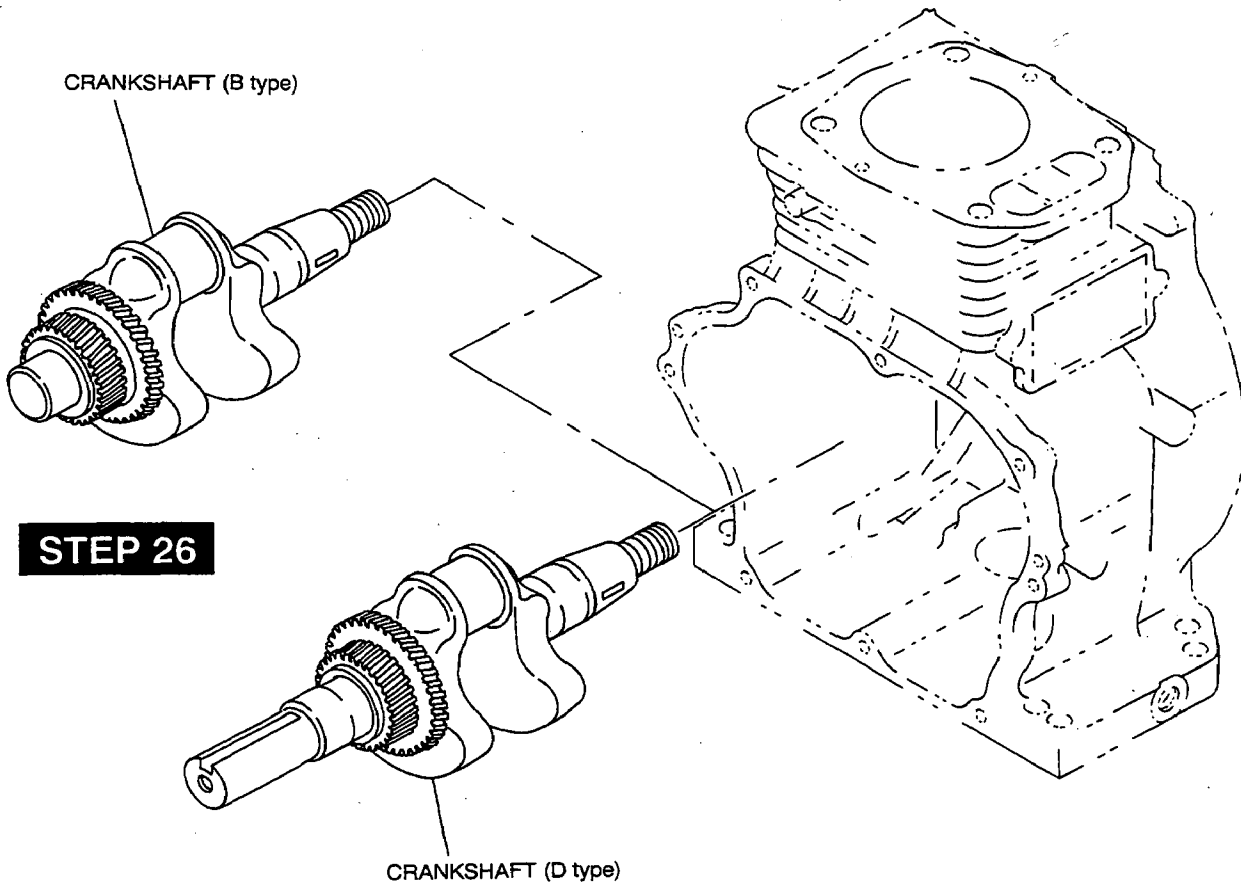

Fig. 5-21

Step	Part to remove	Procedures	Remarks	Tool
27	Intake valve and Exhaust valve	(1) Loosen nut and remove bolt (pivot). (2) Remove rocker arms. (3) Press down spring retainer, take out collet valve, and then remove spring retainer and valve spring (4) Remove intake and exhaust valve. (See Fig. 5-23.)	Inspect valves, valve seats and guide. Do not remove valve guides unless they are worn beyond the limit shown in page 58.	

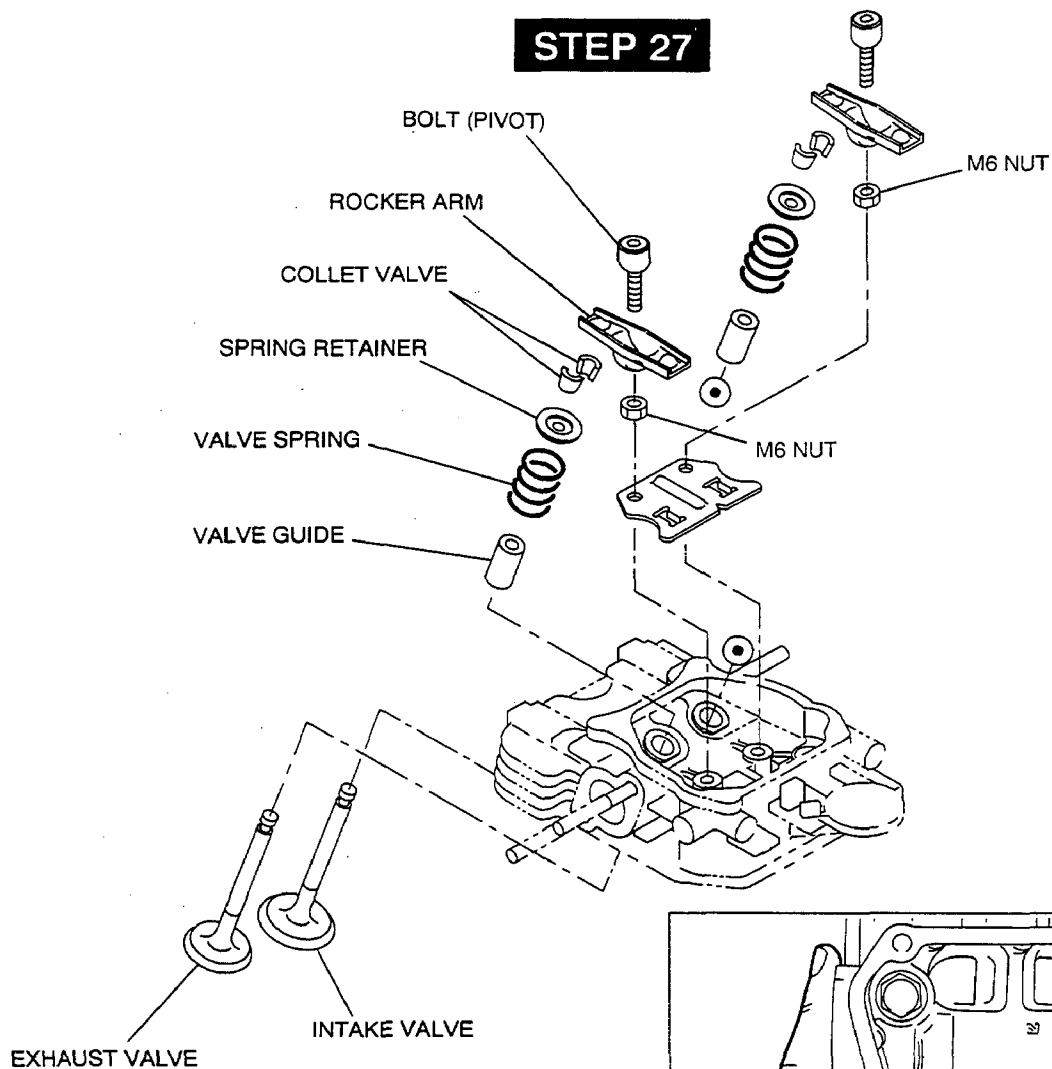

Fig. 5-24

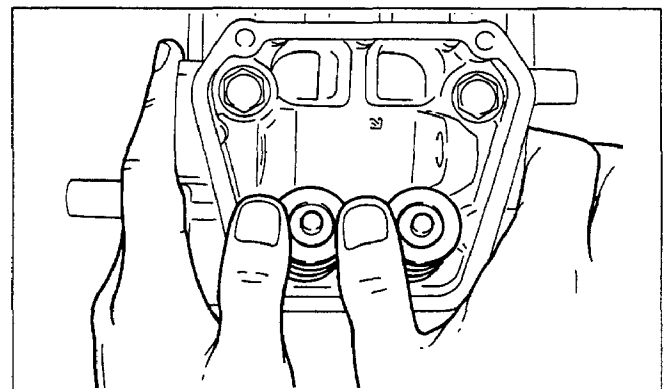

Fig. 5-23

5-4 REASSEMBLY PROCEDURES

● PRECAUTIONS FOR REASSEMBLY

- 1) Clean parts thoroughly before reassembly.
Pay most attention to cleanliness of piston, cylinder, crankshaft, connecting rod and bearings.
- 2) Scrape off all carbon deposits from cylinder head, piston top and piston ring grooves.
- 3) Check lip of oil seals. Replace oil seal if the lip is damaged.
Apply oil to the lip before reassembly.
- 4) Replace all the gaskets with new ones.
- 5) Replace keys, pins, bolts, nuts, etc., if necessary.
- 6) Torque bolts and nuts to specification referring to the "TORQUE SPECIFICATIONS".
- 7) Apply oil to rotating and sliding portions.
- 8) Check and adjust clearances and end plays where specified in this manual.

5-4-1 CRANKSHAFT

- (1) Install crankshaft on crankcase lapping the shaft with polyvinyl tape to avoid damage to oil seal.
- (2) Install woodruff key for the flywheel on crankshaft.

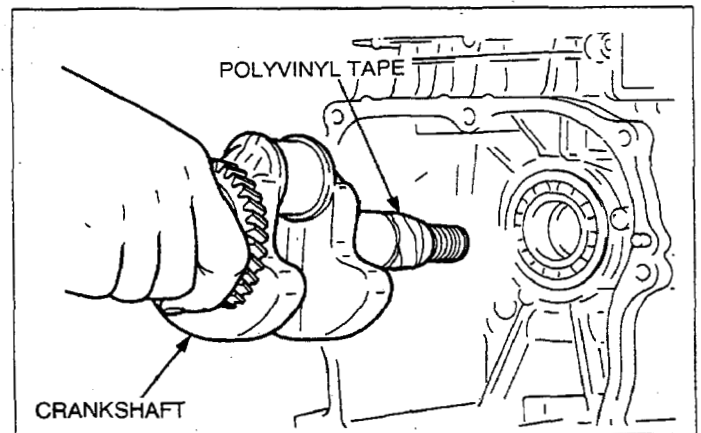

Fig. 5-26

5-4-2 PISTON AND PISTON RINGS

- (1) Install the oil ring first, then second ring and top ring.
Spread the ring only far enough to slip over the piston and into the correct groove. Use care not to distort the ring.
Install the second ring with the punched mark "R" or "N" beside the gap on the top side. (See Fig. 5-29.)

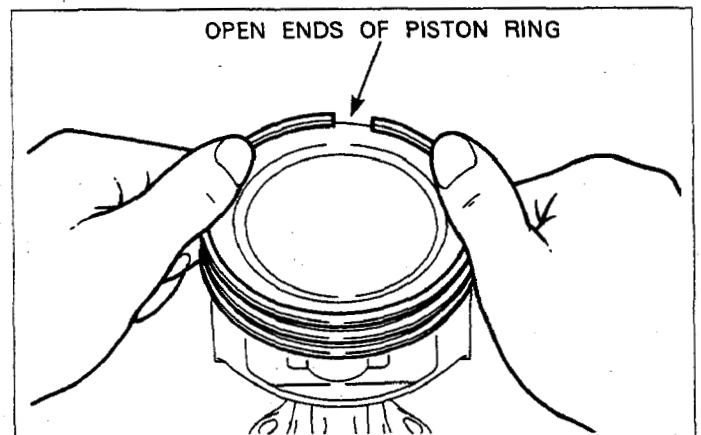

Fig. 5-27

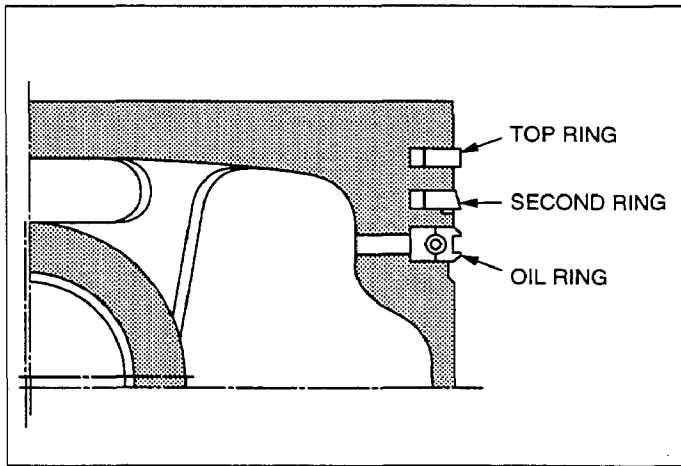

Fig. 5-28

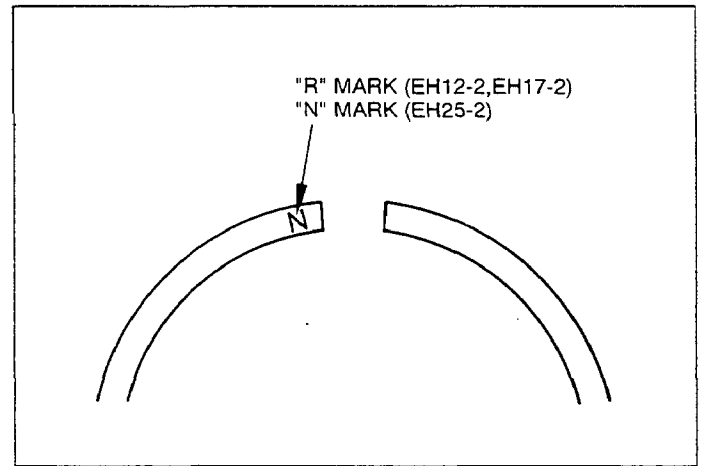

Fig. 5-29

5-4-3 PISTON AND CONNECTING ROD

(1) When installing the piston on the connecting rod, place the valve recess of the piston crown as shown in the illustration to the "MAG" side of the connecting rod.

Apply oil to the small end of the connecting rod, piston and piston pin before installation.

Be sure to use clips on the both end of the piston pin to secure the pin in position.

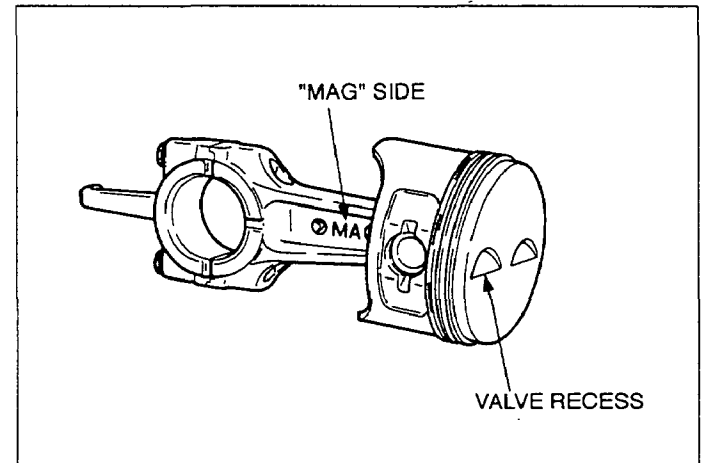

Fig. 5-30

- (2) Install the piston and connecting rod assembly into the cylinder.

Use a piston ring compressor to hold the piston rings.

Place "MAG" side of the connecting rod on the magneto side of the crankcase.

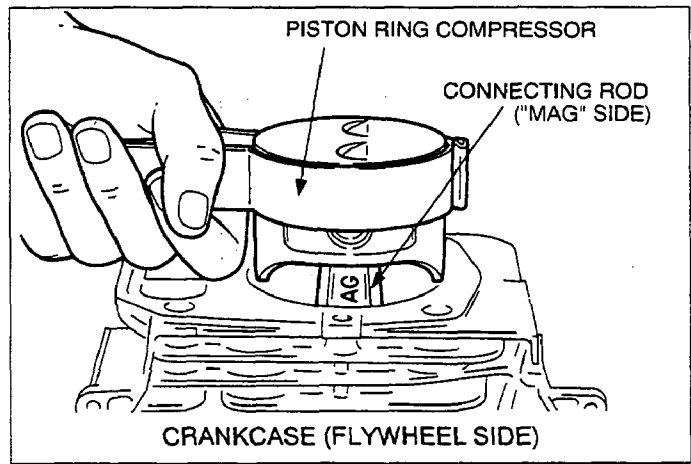

Fig. 5-31

[NOTES]

- (1) Apply enough oil to piston rings, connecting rod bearings and cylinder bore before assembly.

- (2) Set gaps of the piston rings 90 degrees apart from each other before assembly.

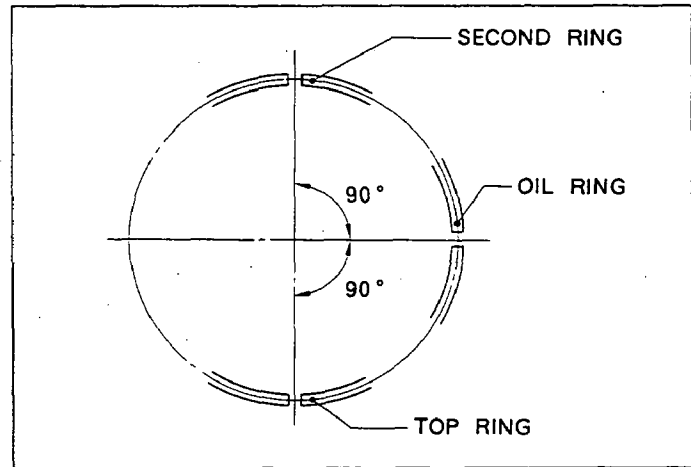

Fig. 5-32

5-4-4 CONNECTING ROD

- (1) Turn crankshaft to bottom dead center, lightly tap top of the piston until large end of the rod meet crankpin.

- (2) Install the connecting rod cap to the connecting rod matching alignment marks.

Torque connecting rod bolts to specification.

M6 × 34 mm flange bolt 2pcs. (EH12-2)

M7 × 37 mm flange bolt 2pcs. (EH17-2)

M8 × 46 mm flange bolt 2pcs. (EH25-2)

CONNECTING ROD BOLT TIGHTENING TORQUE

EH12-2	EH17-2	EH25-2
9-11 N•m	17-19.5 N•m	22-27 N•m
90-115 kg•cm	170-200 kg•cm	225-275 kg•cm
6.5-8.3 ft•lb	12.3-14.5 ft•lb	16.3-19.9 ft•lb

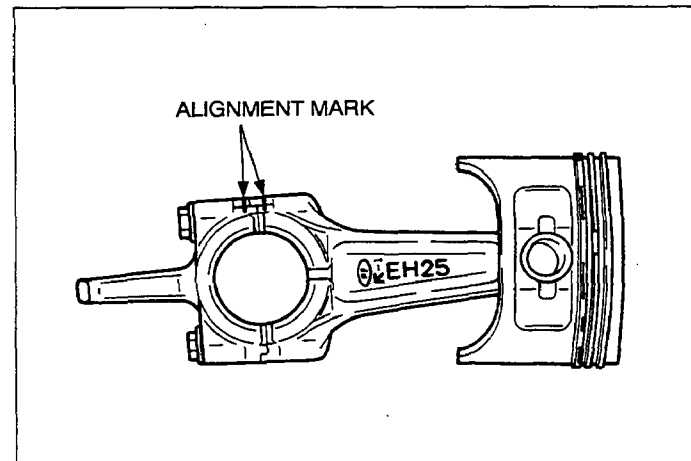

Fig. 5-33

- (3) Check for free movement of connecting rod by turning crankshaft slowly.

5-4-5 BALANCER SHAFT (Option for EH25)

Install balancer shaft aligning the timing mark on the balancer shaft gear and the balancer gear on the crank shaft as shown in the illustration.

CAUTION

Incorrect timing of the gears will cause malfunction of the engine and may result in damage due to interference of the parts.

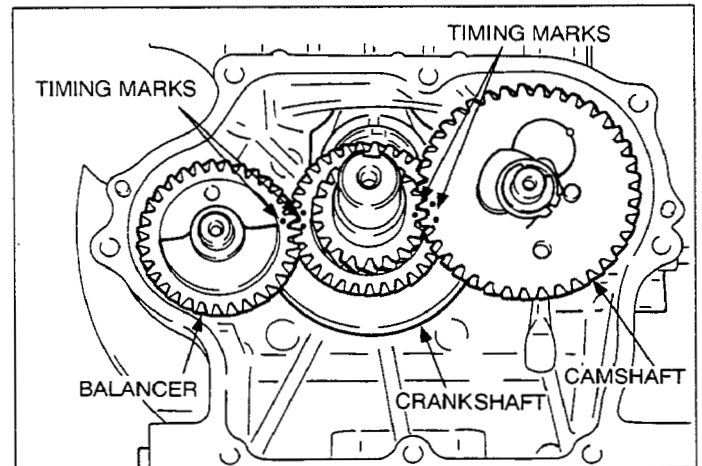

Fig. 5-34

5-4-6 TAPPET AND CAMSHAFT

(1) Oil the tappets and install them in their original position.

Push in fully to avoid damage during the installation of the camshaft.

(2) Lubricate the bearing surfaces of camshaft.

Align the timing mark on the crankshaft gear with the timing mark on the camshaft and install the camshaft in the crankcase as shown in the illustration.

CAUTION

Incorrect valve timing will cause engine's malfunction.

5-4-7 ADJUST CRANKSHAFT AND CAMSHAFT END PLAY

(1) Adjust end play to the specified values using the proper spacer.

The proper spacer may be determined following manner.

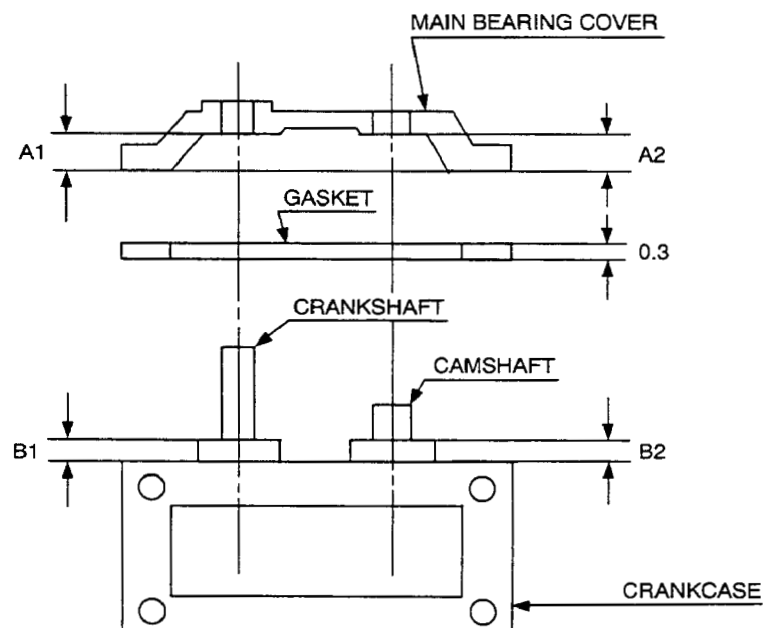

Fig. 5-35

5-4-7-1 CRANKSHAFT END PLAY (For D type and B type)

(1) Measure the depth "A1" (From the mating surface to the inner race of the ball bearing.)

(2) Measure the height "B1" (From the mating surface to the crank gear.)

$$(A1 + 0.3) - B1 = \text{SIDE CLEARANCE (mm)}$$

$$(\text{SIDE CLEARANCE}) - 0.2 = \text{THICKNESS OF CRANKSHAFT SHIM (mm)}$$

$$(A + 0.012") - B1 = \text{SIDE CLEARANCE (in)}$$

$$\text{SIDE CLEARANCE} - 0.008" = \text{THICKNESS OF CRANKSHAFT SHIM (in)}$$

5-4-7-2 CAMSHAFT END PLAY (Model B=2:1 Reduction type only)

(1) Measure the depth "A2" (From the mating surface to the inner race of the camshaft bearing.)

(2) Measure the height "B2" (From the mating surface to the camgear inner boss.)

$$(A2 + 0.3) - B2 = \text{SIDE CLEARANCE (mm)}$$

$$(\text{SIDE CLEARANCE}) - 0.2 = \text{THICKNESS OF CAMSHAFT SHIM (mm)}$$

$$(A2 + 0.012") - B2 = \text{SIDE CLEARANCE (in)}$$

$$\text{SIDE CLEARANCE} - 0.008" = \text{THICKNESS OF CAMSHAFT SHIM (in)}$$

Following are available spacer shims.

EH12-2, EH17-2 type

	CRANKSHAFT	CAMSHAFT
SPACER SHIMS	T=0.6 mm (0.024") T=0.8 mm (0.031") T=1.0 mm (0.039")	T=0.6 mm (0.024") T=0.8 mm (0.031") T=1.0 mm (0.039")

EH25-2 type

	CRANKSHAFT(For D type)	CRANKSHAFT(For B type)	CAMSHAFT
SPACER SHIMS	T=0.6 mm (0.024") T=0.8 mm (0.031") T=1.0 mm (0.039")	T=2.7 mm (0.106") T=2.9 mm (0.114") T=3.1 mm (0.122")	T=0.6 mm (0.024") T=0.8 mm (0.031") T=1.0 mm (0.039")

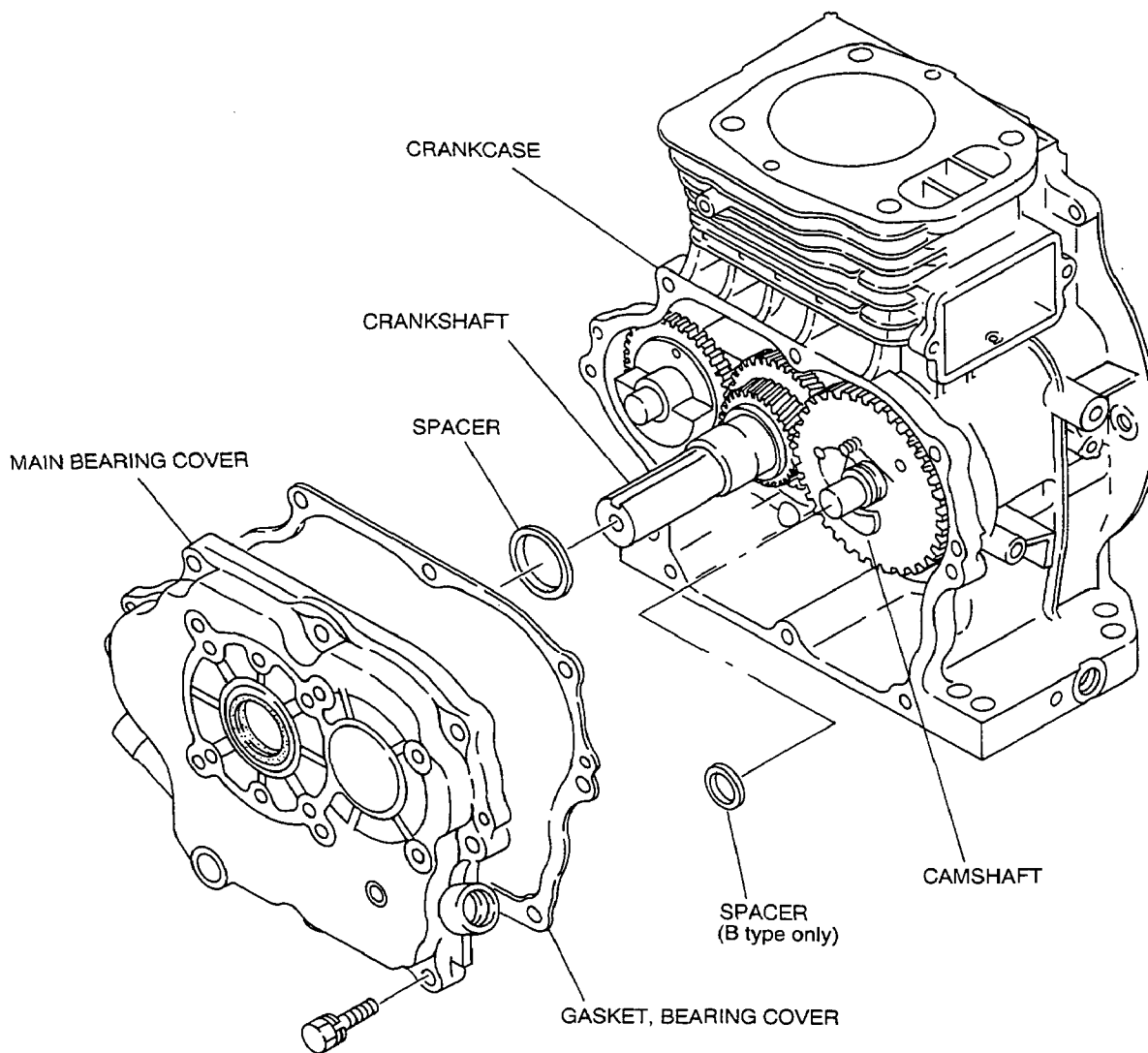

Fig. 5-36

(2) Lubricate the oil seal and bearing surfaces. Add a light film of oil on the main bearing cover face to hold the gasket in place.

Place spacers chosen at procedure (1) on crankshaft and camshaft.

Use an oil seal guide when installing the main bearing cover to avoid damaging the seal.

Tap the cover into place with a soft hammer.

Main bearing cover EH12-2, 17-2 M6 × 30 mm bolt and washer 8 pcs.

EH25-2 M8 × 30 mm bolt and washer 8 pcs.

Tightening torque (EH12-2, 17-2)
8-9.5 N·m
80-100 kg·cm
6-7 ft·lb

Tightening torque (EH25-2)
17-18.5 N·m
170-190 kg·cm
12.5-13.5 ft·lb

5-4-8 CYLINDER HEAD

- (1) Clean carbon and gum deposits from the valves, seats, ports and guides. Inspect the valves, valve seats and valve guides.
- (2) Replace valves that are badly burned, pitted or warped.
- (3) When installing the valves in the cylinder head, oil the valve stems and insert them into the valve guide.

Then place the cylinder head on a flat table, install the valve springs, spring retainers and collet valves.

- (4) Valve guides should be replaced when the valve stem clearance exceeds specifications (See "SERVICE DATA").

Draw the valve guides out and press the new guides in.

Refer to "SERVICE DATA" for clearance specifications.

After replacing the valves and guides, lap valves in place until a uniform ring shows around the face of the valve. Clean valves and wash cylinder head thoroughly.

- (5) Install cylinder head to cylinder with new head gasket.

Tighten four flange bolts evenly in three steps by the following tightening torque:

Cylinder head M8 × 65 mm flange bolt 4 pcs. (EH12-2, 17-2)

M10 × 75 mm flange bolt 4 pcs. (EH25-2)

Tightening torque (EH12-2, 17-2)		
1st step	2nd step	final step
5 N•m	10 N•m	23-26 N•m
50 kg•cm	100 kg•cm	230-270 kg•cm
3.6 ft•lb	7.2 ft•lb	17-30 ft•lb

Tightening torque (EH25-2)		
1st step	2nd step	final step
9.8 N•m	19.6 N•m	33.3-41.2 N•m
100 kg•cm	200 kg•cm	340-420 kg•cm
7.2 ft•lb	14.5 ft•lb	24.6-30.4 ft•lb

5-4-9 ROCKER ARMS AND PUSH RODS

- (1) Insert push rods into crankcase.

Put push rod tip in the hollow of tappet top.

- (2) Apply oil to the rocker arms and assemble them to the cylinder head using pivot bolt and guide plate.

5-4-10 VALVE CLEARANCE ADJUSTMENT

- (1) Position the piston at the top dead center of the compression stroke. The top dead center may be obtained by placing the key slot on the power take off shaft to :

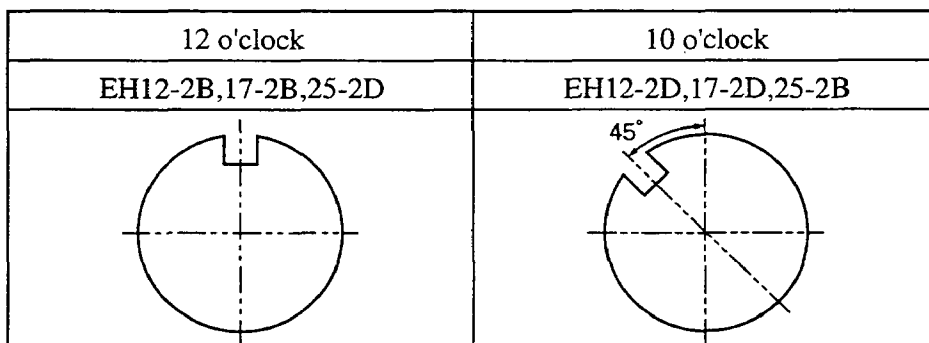

Fig. 5-37

- (2) Loosen the nut under the rocker arm and turn the bolt (pivot) to adjust the clearance between the rocker arm and the valve stem end.
Tighten the nut under the rocker arm.

Valve clearance
0.08-0.12 mm
0.0031-0.0047 in.

[NOTE]

Check and adjust valve clearance while engine is cold.
Check operation of valves by turning crankshaft.
Recheck valve clearance.

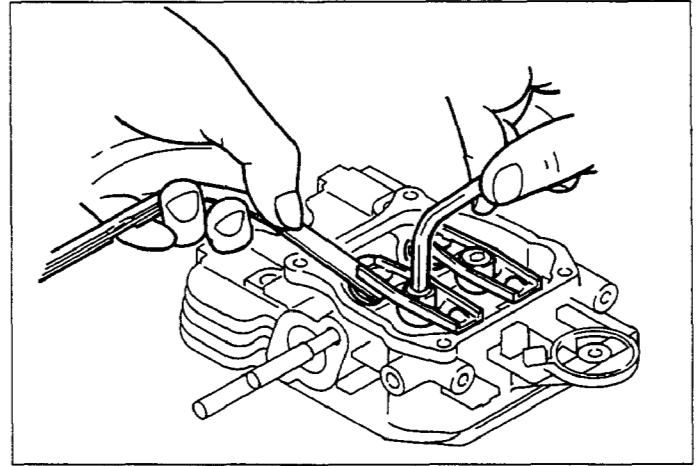

Fig. 5-38

- (3) Install rocker cover and gasket.
Rocker cover M6 × 12 mm bolt 4 pcs.

5-4-11 SPARK PLUG

Install spark plug to the cylinder head.

Spark plug :

EH12-2 : NGK B6ES

EH17-2, 25-2 : NGK B6HS

Tightening torque	
New spark plug	Retightening
11.8-14.7 N·m	22.6-26.5 N·m
120-150 kg·cm	230-270 kg·cm
8.7-10.9 ft·lb	16.6-19.5 ft·lb

5-4-12 FLYWHEEL MAGNETO

- (1) Install the charge coil to the crankcase. (Option)

[NOTE]

Be careful not to pinch coil wire between charge coil and crankcase.

- (2) Put the woodruff key in the key way of crankshaft.
Wipe off oil and degrease thoroughly from the tapered portion of the crankshaft and the flywheel center hole.
- (3) Install the flywheel to crankshaft.
Tighten the flywheel nut with the starter pulley.

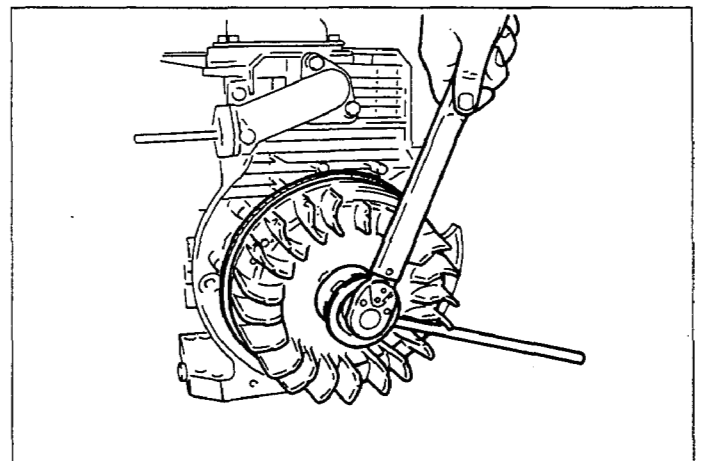

Fig. 5-39

Tightening torque		
59-63 N·m	600-650 kg·cm	43-47 ft·lb

5-4-13 IGNITION COIL

Install the ignition coil to the crankcase.
Adjust the air gap between the ignition coil and the flywheel using a thickness gauge (filler gauge) and tighten the bolts.

Air gap
0.3-0.5 mm
0.012-0.020 in.

Tightening torque		
8.8-10.8 N·m	90-110 kg·cm	6.5-8.0 ft·lb

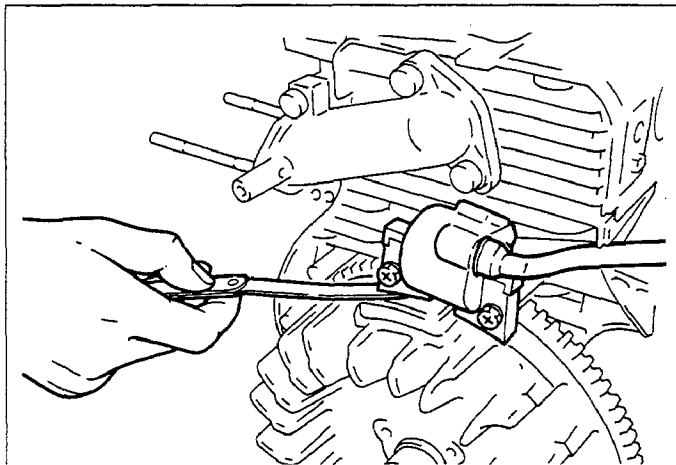

Fig. 5-40

5-4-14 INTAKE PIPE, INSULATOR

- (1) Install the intake pipe to the cylinder head with gasket.
- EH12-2, 17-2 M6 flange nut 2 pcs.
 - M6 × 25mm flange bolt 1 pc.
 - EH25-2 M8 × 28mm bolt and washer 3 pcs.

Tightening torque		
9.8-13.7 N·m	100-140 kg·cm	7.2-10.1 ft·lb

Then put the gasket and the insulator on the intake pipe.

5-4-15 CARBURETOR

Install the gasket and the carburetor to the intake pipe.

5-4-16 GOVERNOR SYSTEM

- (1) Connect the governor lever and the throttle lever on carburetor with governor rod and rod spring. Install the governor lever on the governor shaft.
- (2) Install the speed control lever to the cylinder head.

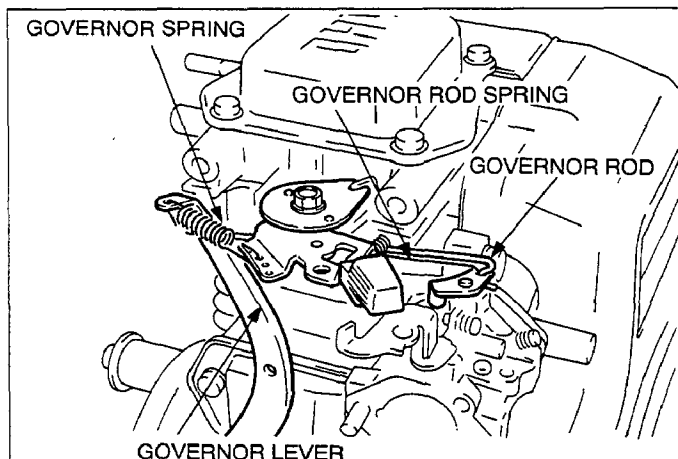

Fig. 5-41

- (3) Connect the speed control lever and the governor lever with the governor spring. The governor spring should be hooked to the number 2 hole on the speed control lever for the regular specifications. Refer to the illustrations below. (See Fig. 5-42.)
- (4) Turn the speed control lever all the way toward the high speed position and make sure that the throttle valve in the carburetor is at the wide open position.
- (5) Turn the governor shaft clockwise all the way using a screw driver, and tighten the lock bolt and nut. (See Fig. 5-43.)

For the generator applications, there are two different governor springs existing according to the speed setting of the engine. The governor springs may be distinguished by the following table. The governor spring employed on the 60Hz application is same as the one from the standard specifications.

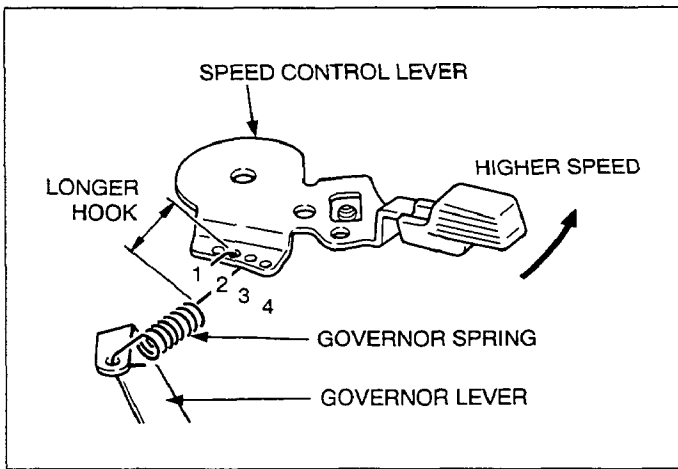

Fig. 5-42

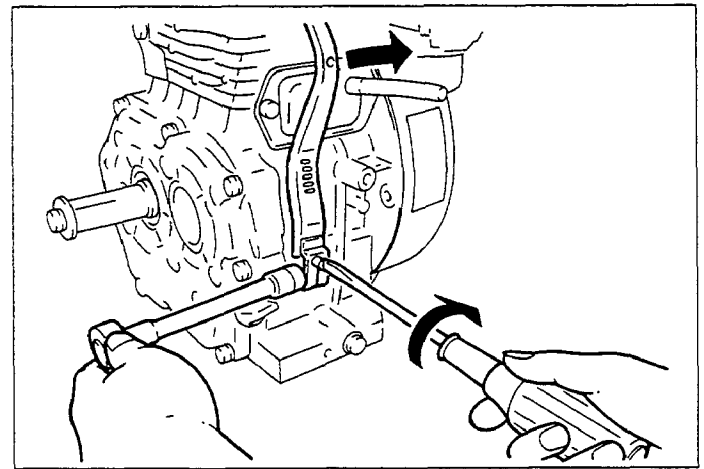
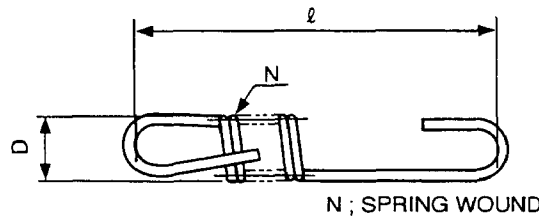

Fig. 5-43



	EH12-2		EH17-2		EH25-2	
	50 Hz (3000 rpm)	60 Hz (3600 rpm)	50 HZ (3000 rpm)	60 Hz (3600 rpm)	50 HZ (3000 rpm)	60 Hz (3600 rpm)
l	49 (1.9")	←	38 (1.5")	←	43 (1.7")	←
D	9.1 (0.35")	8.1 (0.32")	10.7 (0.42")	9.6 (0.38")	8.7 (0.34")	←
N	12.5	←	8.5	←	19.5	16.5
Color	Gold	Silver	Gold	Silver	Gold	Silver

5-4-17 AIR CLEANER

Install the air cleaner gasket and the cleaner case and tighten them with 2-M6 flange nuts. Then install the element and the cleaner cover.

5-4-18 HEAD COVER

Install the head cover to the cylinder head.

M6 × 12mm flange bolt 1 pc.

5-4-19 MUFFLER, MUFFLER COVER and EXHAUST PIPE COVER

Install the muffler to the cylinder head.

M8 flange nut 2 pcs.

Tightening torque
22.5-26.5 N·m
230-270 kg·cm
16.6-19.5 ft·lb

Then tighten the muffler bracket portion.

M6 × 12mm flange bolt 1 pc. (EH12-2, 17-2)

M8 × 16mm flange bolt 1 pc. (EH25-2)

Install the muffler cover and exhaust pipe cover.

M6 × 10mm flange bolt 5 pcs.

5-4-20 BLOWER HOUSING, RECOIL

Install the blower housing and the recoil. Insert the high tension cord from the ignition coil into the notch of the blower housing so that not to pinch the cord.

5-4-21 FUEL TANK

Install the fuel tank. Connect the fuel strainer and the fuel inlet on carburetor with the fuel hose.

M6 × 14mm bolt and washer 4 pcs. (EH12-2, 17-2)

M8 × 20mm bolt and washer 4 pcs. (EH25-2)

— End of the reassembly —

5-5 BREAK-IN OPERATION

An engine that has been completely overhauled by being fitted with a new piston, rings, valves and connecting rod should be thoroughly RUN-IN before being put back into service.

Good bearing surfaces and running clearances between the various parts can only be established by operating the engine under reduced speed and loads for a short period of time.

While the engine is being tested, check for oil leaks.

Make final carburetor adjustment and regulate the engine operating speed.

Steps	Load	Engine speed	Time
Step 1	No load	2500 rpm	10 min
Step 2	No load	3000 rpm	10 min
Step 3	No load	3600 rpm	10 min
Step 4	EH12-2 EH17-2 EH25-2	1.0 KW (1.4 HP) 1.5 KW (2.0 HP) 2.4 KW (3.2 HP)	3600 rpm 30 min
Step 5	EH12-2 EH17-2 EH25-2	2.1 KW (2.8 HP) 2.9 KW (4.0 HP) 4.7 KW (6.4 HP)	3600 rpm 60 min

6. IGNITION SYSTEM

6-1 TYPE OF IGNITION SYSTEM

EH12-2 employs the U. T. C. I. (Universal type Transistor Controlled Ignition) pointless ignition system.

EH17-2 and EH25-2 have the T. I. C. (Transistor, Igniter, Circuit) pointless ignition system.

As optional parts, these ignition system may be implemented with lamp coil, charge coil and excitor coil.

6-2 BASIC THEORY

To ensure the easy startability of the engine, the step advancing ignition timing system is incorporated in the ignition coil. This system enables the engine to have basically two different ignition timings according to the engine speed. Following are the explanation how the system works.

1) At lower speed of the engine

Rotation of the flywheel induces current I_1 , as this current flows through the base terminal of the power transistor, it is activated and the current I_2 starts flowing.

As the engine reaches the ignition timing, the ignition timing control circuit for the lower engine speed is activated and lets the current I_3 flow through the base terminal of the power transistor.

This generates the collector current I_4 which will bypass the current I_1 and abruptly shut off the current I_2 because the power transistor is turned off.

This sudden current change generates a big voltage on the secondary side of the ignition coil and which sparks the spark plug.

2) At the higher engine speed

Rotation of the flywheel generates the current I_1 as this current flows through the base terminal of the power transistor, it is activated and the current I_2 starts of flow.

As the engine reaches the ignition timing, the ignition timing control circuit for the higher engine speed is activated and provides the base current I_3 to the power transistor. This current induces the collector current I_6 and will bypass the current I_1 to shut down the current I_2 abruptly because the power transistor is turned off.

This sudden current change generates a big voltage on the secondary side of the ignition coil and which will spark the spark plug.

The ignition timing control circuit for the higher engine speed is activated sooner than the control circuit for the lower speed and not activated when the engine speed is in a lower range.

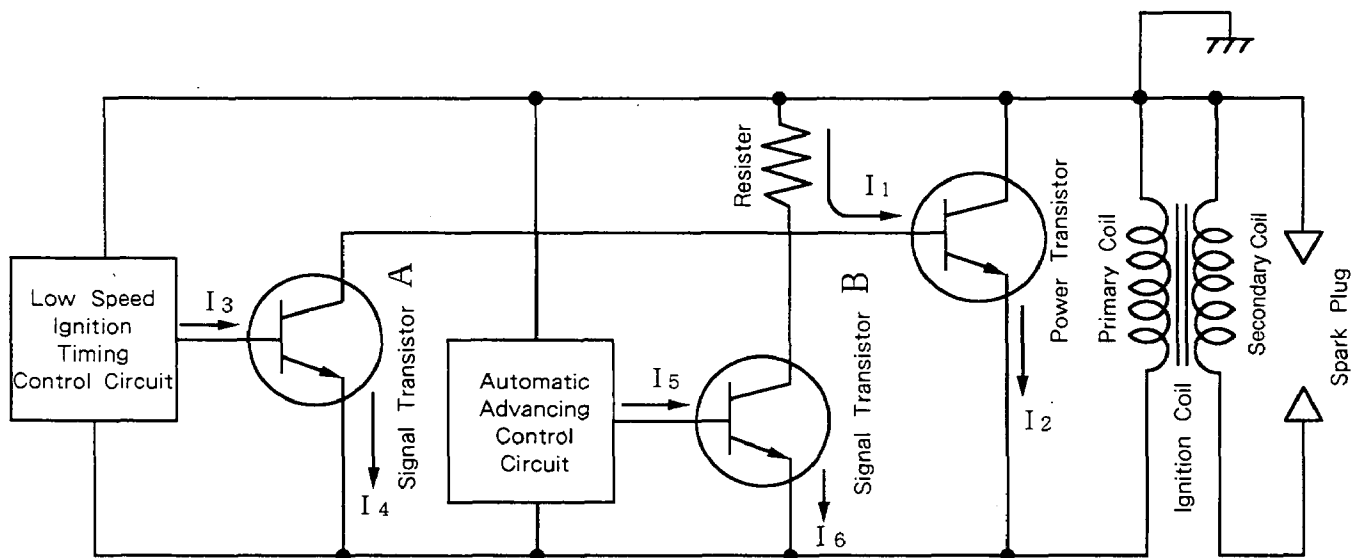

Fig. 6-1 (a)

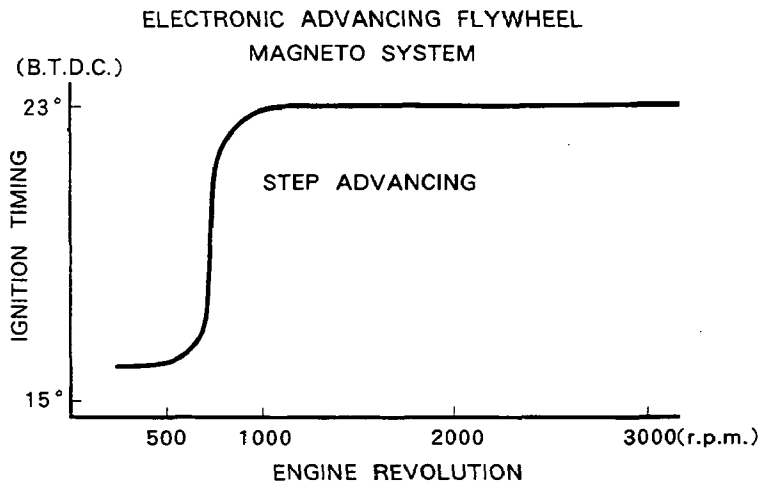

Fig. 6-2 (b)

6-3 WIRING DIAGRAM

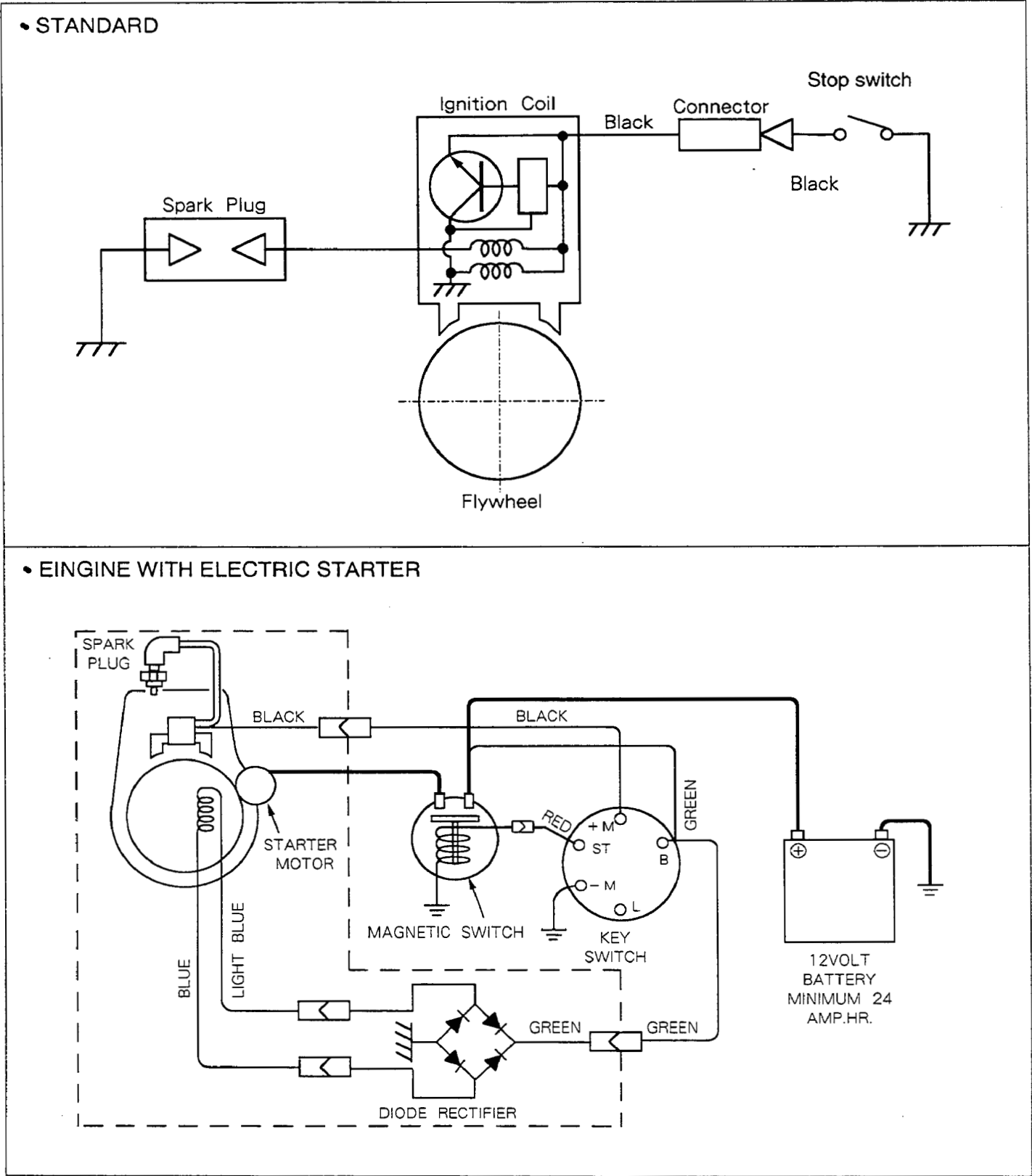

Fig. 6-3

7. AUTOMATIC DECOMPRESSION SYSTEM

EH12-2, 17-2, 25-2 engines are employing the automatic decompression system as a standard feature. This enables easy and light start of the engine.

The automatic decompression system releases the compression of the engine by lifting up the exhaust valve at the cranking. Following are the explanation using type "D" engine as a sample how the system works. The components of the systems are different for the type "D" and type "B" engines, however, the principle of the function is same.

At the end of the compression process, the release lever lifts up the tappet which in turns opens up the exhaust valve slightly to release the compression. The release lever has a flyweight on its end and another end of the lever is a crescent cam.

When the engine is cranked, the crescent cam projects the camshaft cam profile and lifts up the tappet because the gravity force on the weight is larger than the centrifugal force on the weight.

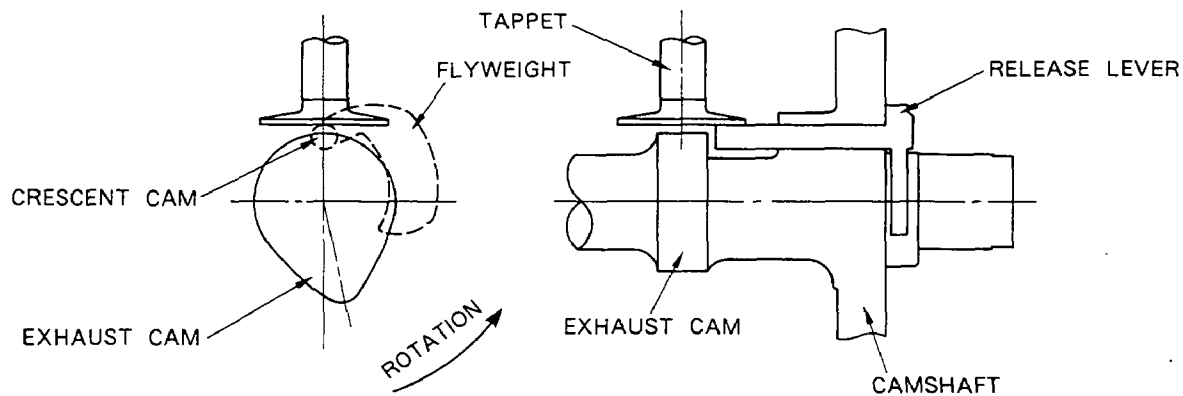

Fig. 7-1

When the crank speed reaches up to a certain revolution, the crescent cam is retracted into the camshaft cam profile because the centrifugal force applied onto the flyweight becomes larger than the gravity force and the weight and is shifted to the position shown in the illustration.

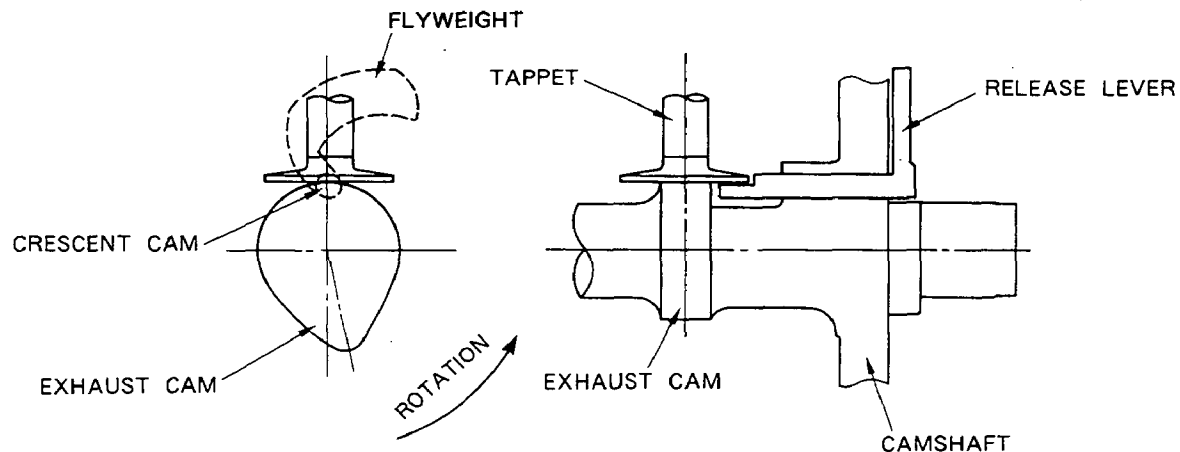

Fig. 7-2

8. CARBURETOR

8-1 OPERATION AND CONSTRUCTION

8-1-1 FLOAT SYSTEM

The float chamber is located below the carburetor body and, with a float and a needle valve, maintains a constant fuel level during the engine operation.

The fuel flows from the fuel tank into the float chamber through the needle valve. When the fuel rises to a specific level, the float rises, and when its buoyancy and fuel pressure are balanced, the needle valve shuts off the fuel, thereby keeping the fuel at the predetermined level.

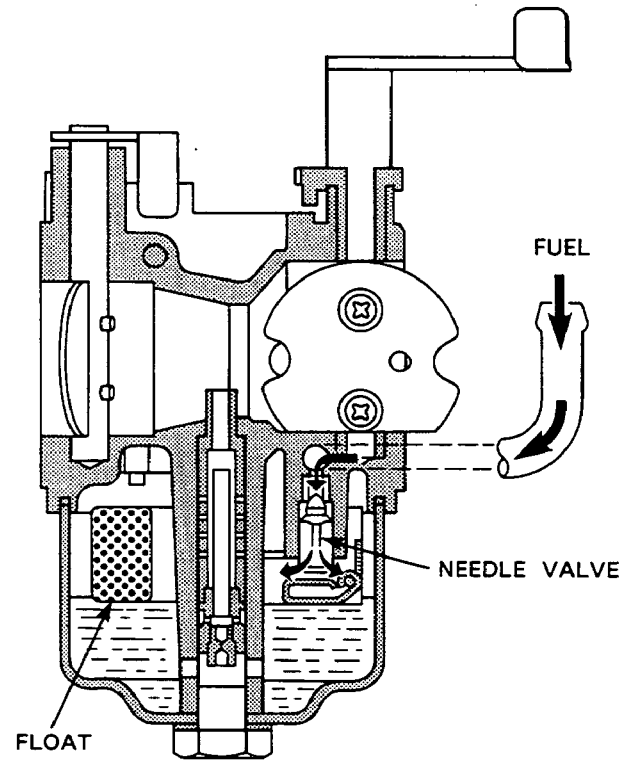

Fig. 8-1

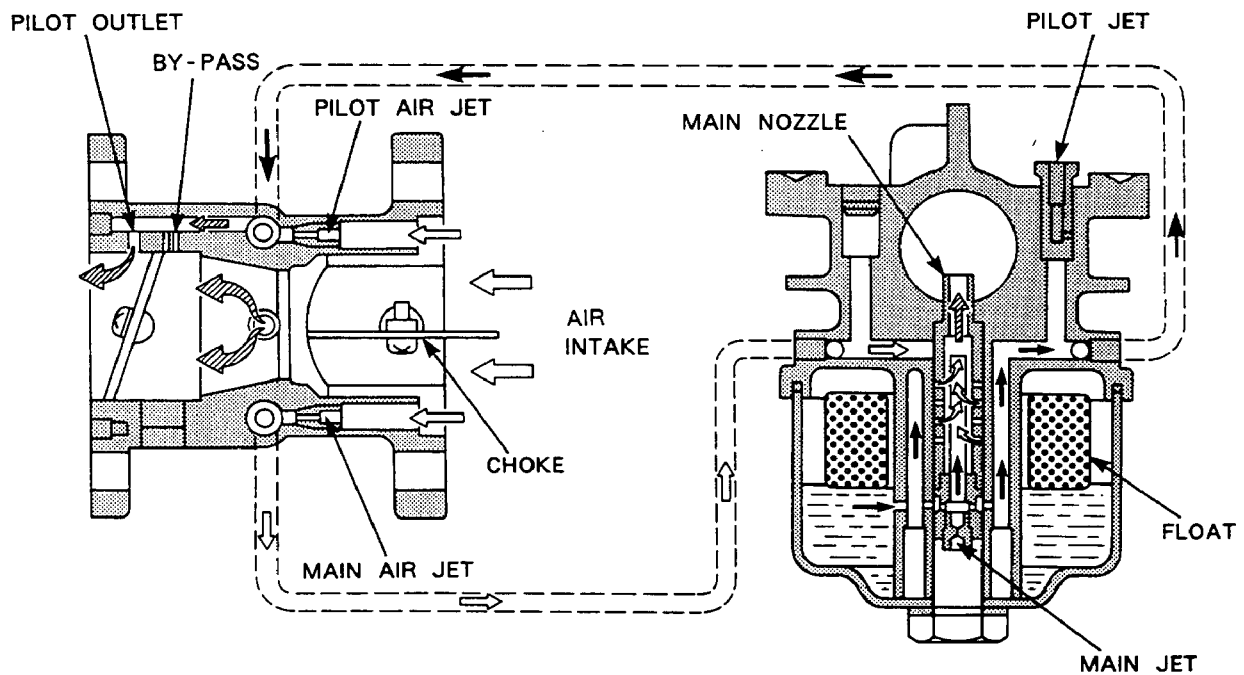

Fig. 8-2

8-1-2 PILOT SYSTEM

The pilot system feeds the fuel to the engine during idling and low-speed operation.

The fuel is fed through the main jet to the pilot jet, where it is metered, and mixed with the air metered by the pilot air jet.

The fuel-air mixture is fed to the engine through the pilot outlet and the by-pass.

At the idling speed, the fuel is mainly fed from the pilot outlet.

8-1-3 MAIN SYSTEM

The main system feeds the fuel to the engine at medium-and high-speed operation.

The fuel is metered by the main jet and fed to the main nozzle. The air metered by the main air jet is mixed with the fuel through the bleed holes in the main nozzle, and the mixture is atomized out of the main bore. It is mixed again with the air taken through the air cleaner into an optimum fuel-air mixture, which is supplied to the engine.

8-1-4 CHOKE

The choke may be used for easy start when engine is cold. When the engine is cranked with a closed choke, the negative pressure applied to the main nozzle increases and draws more fuel accordingly this starting up the engine more easily.

8-2 DISASSEMBLY AND REASSEMBLY

Apart from mechanical failures, most of carburetor troubles are caused by an incorrect mixing ratio, which may arise mainly due to a clogged up air or fuel passage in jets, or fuel level variations. In order to assure proper flow of air and fuel, the carburetor must be kept clean at all times. The carburetor disassembly and reassembly procedures are as follows.

8-2-1 THROTTLE SYSTEM

(1) Remove the philips screw (1) and throttle valve (2), and pull out the throttle shaft (3).

(2) The spring (4) can be taken out by removing the throttle stop screw (5).

* Be careful not to damage the throttle valve rim.

8-2-2 CHOKE SYSTEM

(1) Remove the philips screw (6) and choke valve (7), and pull out the choke shaft (8).

(2) When reassembling the choke shaft, make sure that the cutout in the choke valve faces the main air jet. Meanwhile, when reassembling set the rings (9) and (10) at the right position.

8-2-3 PILOT SYSTEM

(1) Remove the pilot jet (11), using proper tools to avoid damage to it.

(2) Reassembly

Tighten the pilot jet securely. Otherwise, the fuel may leak, causing engine malfunction.

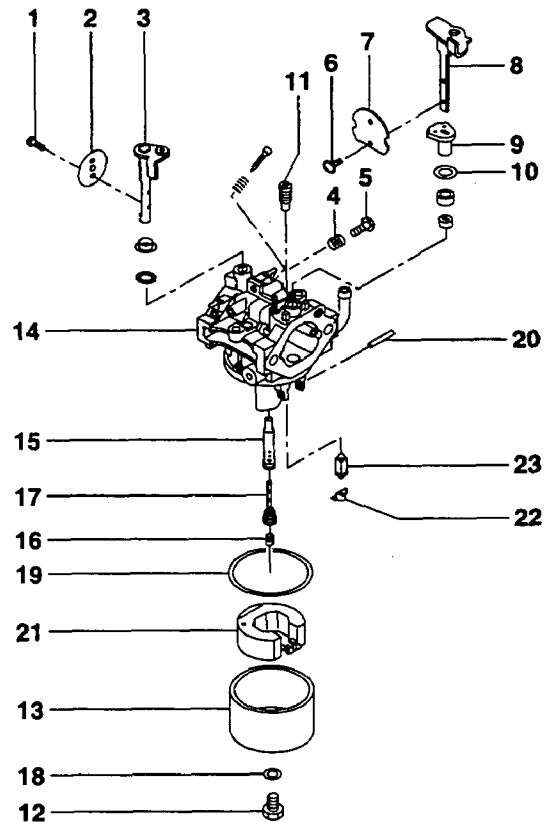

Fig. 8-3

8-2-4 MAIN SYSTEM

- (1) Remove the bolt(12)and take out float chamber body(13).
- (2) From the body (14) remove the main nozzle (15), and then remove the main jet (16) and guide holder (17) from the main nozzle (15).
- (3) Reassembly
 - a) Fasten the main jet securely to the body. Otherwise, the fuel may become too rich and cause engine malfunction.
 - b) The bolt tightening torque is 70kg-cm. Be sure to set the gasket (19) and washer (18) for chamber (13).

8-2-5 FLOAT SYSTEM

- (1) Pull out the float pin (20) and remove the float (21) and then remove the clip (22) and needle valve (23).
If the needle valve needs to be replaced, replace it with rubber needle.

CAUTION

When cleaning the jets, be sure to use compressed air to blow them clean.
Never use a drill or a wire because of possible damage of the orifice which will considerably affect fuel flow.

- (2) When removing the needle valve and float, gently tap the reverse side using the rod more slender than the float pin and remove, since the float pin is calked to the carburetor body.

9. STARTING SYSTEM

9-1 RECOIL STARTER

Equipments to be prepared : Driver, Pinchers (Pliers) and Protective Glasses

WARNING

Before starting the disassembly, make sure to wear the protective glasses.

9-1-1 Disassembly Steps

(1) Setting off the spring power

- 1: Hold the starter knob and extract the starter rope.
- 2: Extract the rope fully and hold the rope so that the knob of the rope in the reel makes a direct line with the rope guide.
- 3: Push and hold the reel with the thumbs of both hands firmly so that the rope will not be wound back. (Fig. 9-1)
- 4: Pull off the knot of the rope out of the reel, unfasten the knot and pull it off to the direction of the starter knob. (2 persons required)
- 5: By controlling the reel with the thumbs of both hands, unwind the rope gently until the rotation of the reel stops.

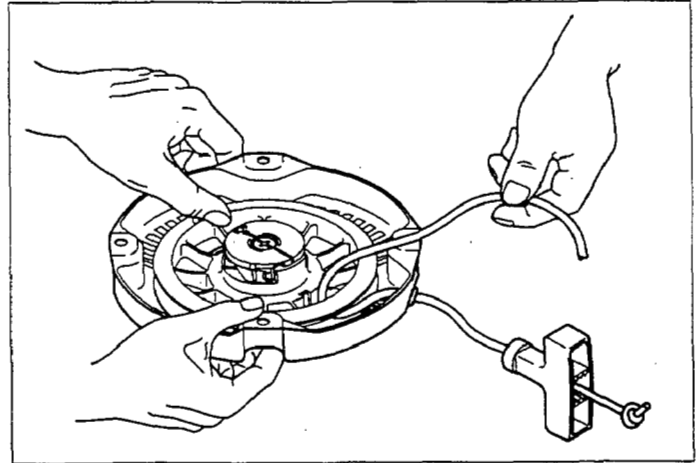

Fig. 9-1

WARNING

The spring power is at its most when the rope is fully extracted. Therefore, do not abruptly put off your hand nor loosen the pressure of your finger unintentionally.

(2) Setting the attachments off (Fig. 9-2)

- 1 : Fix the case and loosen the set-screw.
- 2 : Put off the set-screw, the latchet guide, the friction spring and the latchet in the same order from above.

(3) Setting the reel off (Fig. 9-2)

- 1 : Push the reel lightly so that it will not float up. Move the reel clockwise and counter-clockwise about a quarter circle for several times until it moves smoothly.
- 2 : Pull up the reel gradually and slowly and put it off from the case.
- 3 : In case the spring in the reel is close to pop up, redo the steps of (3)-1 and (3)-2 again.

WARNING

Do not drop or shake the reel and put it on a level table because there is a spring set in the disassembled reel.

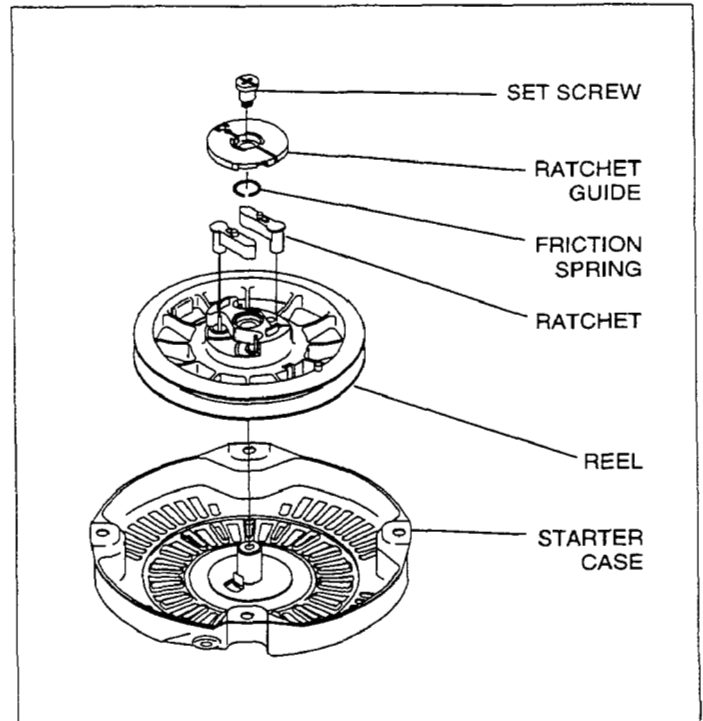

Fig. 9-2

Disassembly is complete.

WARNING

Before starting the assembly, make sure to wear the protective glasses.

9-1-2 Assembly Steps

(1) Setting the reel into the case.

- 1 : Paste grease on the case. (Fig. 9-3)
- 2 : Adjust the position of the inner end of the spring, which is set in the reel. (Fig. 9-4)
- 3 : Hold the reel so that the shaft/hook part and the inner end of the spring are hooked together. Drop the reel gently from above into the case.
- 4 : Move the reel slightly counter-clockwise and make sure the spring is hooked.

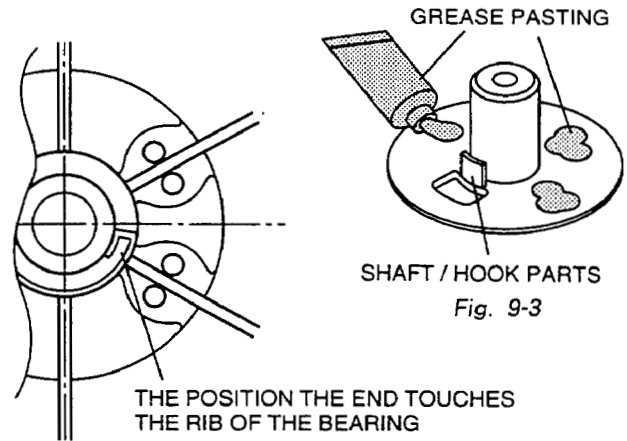

Fig. 9-3

THE POSITION THE END TOUCHES THE RIB OF THE BEARING

Fig. 9-4

(2) Setting the attachments

- 1 : Set the latchet into the reel. (Fig. 9-5)

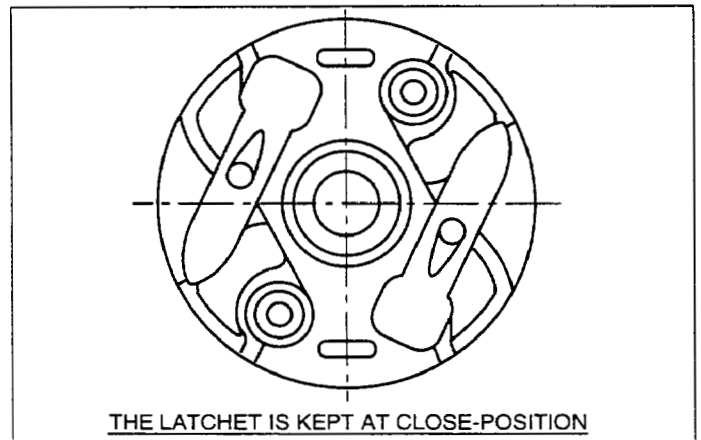

THE LATCHET IS KEPT AT CLOSE-POSITION

Fig. 9-5

- 2 : Holding the latchet, set the latchet-guide sub-assembly. (Fig. 9-6)

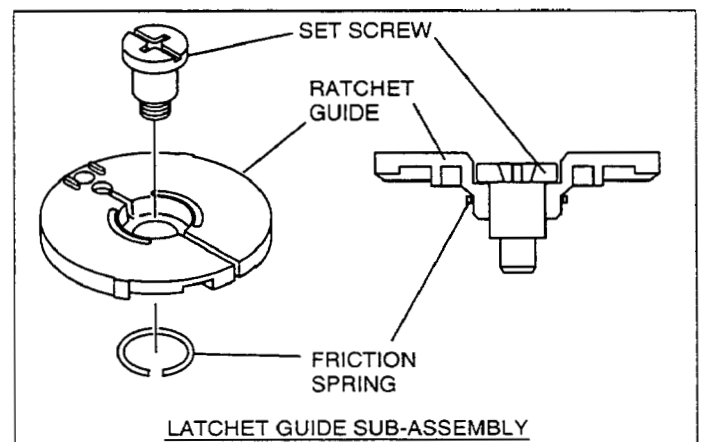

LATCHET GUIDE SUB-ASSEMBLY

Fig. 9-6

- (3) Tightening the set-screw.
- 1: Push the latch-guide lightly by hand so that the latch guide won't move and tighten the set-screw.
- (4) Storing the spring-power.
- 1: Hold the case tight and using both hands, wind up the reel counter-clockwise 6 times.
 - 2: Set the ree to keep the position, whereby the rope hole of the reel and the rope guide make a direct line. (Fig. 9-7)

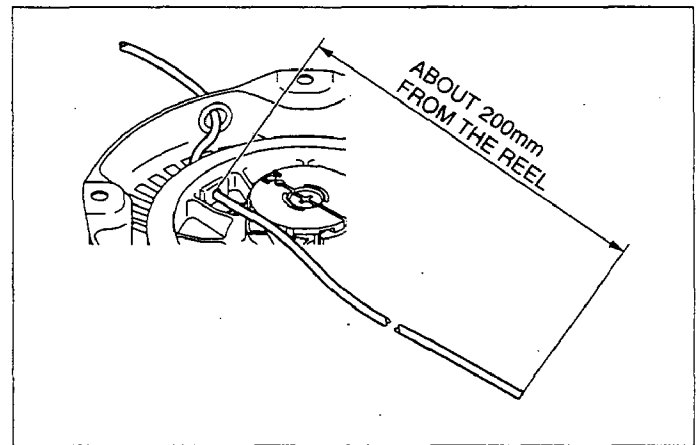

Fig. 9-7

WARNING

The spring power is at its most when the reel is being wound. Therefore, do not abruptly put off your hand nor loosen the pressure of your finger unintentionally.

- (5) Setting the rope. (2 persons required)
- 1: Set the end of the rope through the rope guide and the rope hole of the reel and pull the end about 20 cm out of the reel. (Fig. 9-7)

- 2: Fasten the end of the rope.

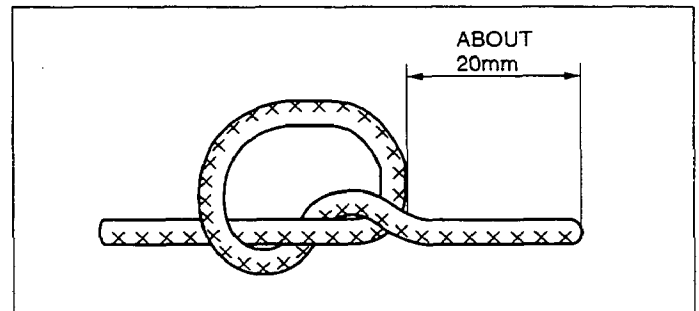

Fig. 9-8

- 3: Put the rope into the reel, whereby make sure that the rope will not float up. (Fig. 9-9)
- 4: Hold the rope firmly with one hand at the position about 50 cm from the rope guide and keep the rope slightly pulled so that the rope will not be wound in.
- 5: Put the hand off the reel gently and put the rope back slowly obeying the winding power of the spring until the knob reaches the rope guide.

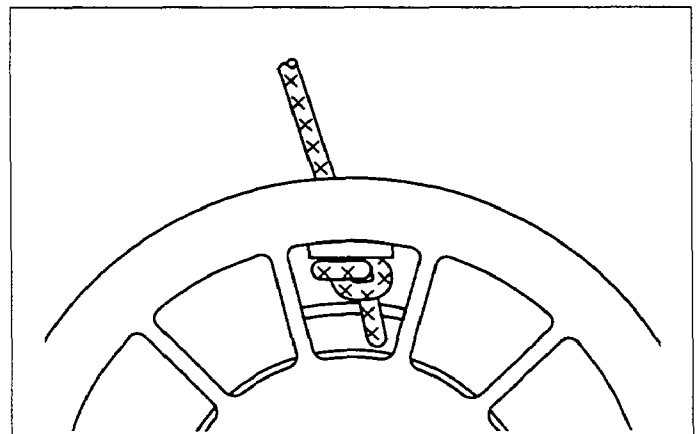

Fig. 9-9

Assembly is complete.

- (6) Test the operation of the recoil starter to see if the rope recoils satisfactorily and the ratchets project and retract properly. Mount the recoil starter to the engine.
- (7) If the spring escapes from the reel when disassembling the recoil, hook the outer end of the spring onto the notch of the reel and rewind the spring into the housing.
- (8) Lubricate the rotating parts, sliding parts and spring with heat resistant grease or mobile oil when reassembling the recoil and prior to long term storage.

10. TROUBLESHOOTING

The following three conditions must be fulfilled for satisfactory engine start.

1. The cylinder filled with a proper fuel-air mixture.
2. Good compression in the cylinder.
3. Good spark, properly timed, to ignite the mixture.

The engine cannot be started unless these three conditions are met. There are also other factors which make engine start difficult, e. g., a heavy load on the engine when it is about to start at low speed, and a high back pressure due to a long exhaust pipe.

The most common causes of engine troubles are given below :

10-1 STARTING DIFFICULTIES

10-1-1 FUEL SYSTEM

- (1) No gasoline in the fuel tank ; or the fuel cock closed.
- (2) The carburetor is not choked sufficiently especially when the engine is cold.
- (3) Water, dust or gum in the gasoline interfering the fuel flow to the carburetor.
- (4) Inferior grade gasoline or poor quality gasoline not vaporized enough to produce the correct fuel-air mixture.
- (5) The carburetor needle valve is held open by dirt or gum. This trouble can be detected as the fuel flows out of the carburetor when the engine is idling. (Overflow)
This trouble may be remedied by lightly tapping the float chamber with the grip of a screwdriver or the like.
- (6) If the carburetor overflows, excessive fuel runs into the cylinder when starting the engine, making the fuel-air mixture too rich to burn. If this happens, remove the spark plug, and turn the starting pulley a few turns in order to let the rich fuel-air mixture out of the spark plug hole into the atmosphere. Keep the choke valve open during this operation. Dry the spark plug well, screw it into place, and try to start again.

10-1-2 COMPRESSION SYSTEM

If starting difficulties and loss of power are not due to the fuel system or ignition system, the followings must be checked for possible lack of compression.

- (1) Engine inside is completely dried up because of a long period of storage.
- (2) Loose or broken spark plug. This causes a hissing noise made by mixture gas running out of cylinder in compression stroke during cranking.
- (3) Damaged head gasket or loose cylinder head. A similar hissing noise is produced during compression stroke.
- (4) Incorrect Valve clearance

If the correct compression is not obtained even after remedying the above, disassemble the engine and check further as follows :

- a) Valve stuck open due to carbon or gum on the valve stem.
- b) If the piston rings are stuck on the piston, remove the piston and connecting rod from the engine.
Clean or replace the parts.

10-1-3 IGNITION SYSTEM

Check the followings for lack of sparks.

- (1) Wires of the ignition coil, spark plug or contact breaker disconnected.
- (2) Ignition coil damaged and shorted.
- (3) Spark plug cable wet or soaked with oil.
- (4) Spark plug dirty or wet.
- (5) Spark plug electrode gap incorrect.
- (6) Spark plug electrodes are connected or bridged.
- (7) Incorrect spark timing.

10-2 ENGINE MISFIRES

- (1) Incorrect spark plug electrode gap. Adjust it to anywhere between 0.6 and 0.7mm.
- (2) Ignition cable worn and leaking.
- (3) Sparks weak.
- (4) Ignition wire connections loose.
- (5) Water in gasoline.
- (6) Insufficient compression.

10-3 ENGINE STOPS

- (1) Fuel tank empty. Water, dirt, gum, etc. in gasoline.
- (2) Vapor lock, i. e., gasoline evaporating in the fuel lines due to overheat around the engine.
- (3) Vapor lock in the fuel lines or carburetor due to the use of too volatile winter gas in the hot season.
- (4) Air vent hole in the fuel tank cap plugged.
- (5) Bearing parts seized due to lack of oil.
- (6) Magneto or ignition coil faulty.

10-4 ENGINE OVERHEATS

- (1) Crankcase oil level low. Add oil immediately.
- (2) Spark timing incorrect.
- (3) Low grade gasoline is used, or engine is overloaded.
- (4) Cooling air circulation restricted.
- (5) Cooling air path misdirected causes loss of cooling efficiency.
- (6) Cylinder head cooling fins clogged up with dirt.
- (7) Engine operated in an enclosed space without sufficient cooling air.
- (8) Exhaust gas discharge restricted, or carbon deposits in the combustion chamber.
- (9) Engine running on low-octane gasoline detonates due to heavy load at low speed.

10-5 ENGINE KNOCKS

- (1) Poor quality gasoline.
- (2) Engine operating under heavy load at low speed.
- (3) Carbon or lead deposits in the cylinder head.
- (4) Spark timing incorrect.
- (5) Loose connecting rod bearing due to wear.
- (6) Loose piston pin due to wear.
- (7) Causes of engine overheat.

10-6 ENGINE BACKFIRES THROUGH CARBURETOR

- (1) Water or dirt in gasoline, or low-grade gasoline.
- (2) Intake valve stuck.
- (3) Valves overheated, or hot carbon particles in the combustion chamber.
- (4) Engine cold.

11. INSTALLATION

Engine life, ease of maintenance and inspection, frequency of checks and repairs, and operating cost all depend on the way in which the engine is installed. Review the following instructions carefully for installing the engine.

11-1 INSTALLING

When mounting the engine, carefully examine its position, the method of connecting it to a machine, the foundation, and the method of supporting the engine.

When determining its mounting position, in particular, make sure that gasoline and oil can easily be supplied and checked, the spark plug can easily be checked, the air cleaner can easily be serviced, and that the oil can easily be discharged.

11-2 VENTILATION

Fresh air is necessary for cooling the engine and burning the fuel.

In the case the engine is operated under a hood or in a small room, temperature rise in the engine room can cause vapor lock, oil deterioration, increased oil consumption, loss of power, piston seizure, shorter engine life, etc., making it impossible to operate the engine properly. It is necessary, therefore, to provide a duct or baffle to guide cooling air to the engine to prevent recirculation of the hot air used for engine cooling, and temperature rise of the machine.

Keep the engine room temperature below 50°C even in the hottest period of the year.

11-3 EXHAUST GAS DISCHARGE

Exhaust gas is noxious. When operating the engine indoors, be sure to discharge the exhaust gas outdoors. If a long exhaust pipe is used in such a case, the internal resistance increases causing loss of engine power. Thus pipe inside diameter must be increased in proportion to exhaust pipe length.

Exhaust pipe: Less than 3m long, pipe inside diameter 30mm,
Less than 5m long, pipe inside diameter 33mm.

11-4 POWER TRANSMISSION TO DRIVEN MACHINES

11-4-1 BELT DRIVE

Take the following notes into consideration.

- * V-belts are preferable to flat belts.
- * The driving shaft of the engine must be parallel to the driven shaft of the machine.
- * The driving pulley of the engine must be in line with the driven pulley of the machine.
- * Install the engine pulley as close to the engine as possible.
- * If possible, span the belt horizontally.
- * Disengage the load when starting the engine.

If no clutch is used, use a belt tension pulley or the like.

11-4-2 FLEXIBLE COUPLING

When using a flexible coupling, runout and misalignment between the driven shaft and engine shaft must be minimized. Runout and misalignment tolerance are specified by the coupling manufacturer.

12. SERVICE DATA

“STD” in the following table is the parts dimension from the brand new engine or the spare parts. Whereas, “Limit” shows the maximum allowance for the parts to be used on the engine. If the measurement exceeds beyond the “Limit”, the part needs to be replaced and/or repaired.

12-1 CLEARANCE DATA AND LIMITS

Unit : mm (in)

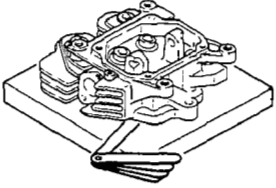
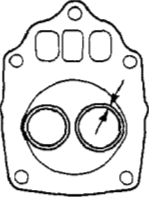
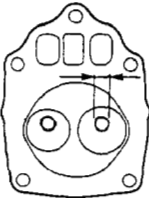
ITEM	EH12-2/17-2/25-2		
	STD	Limit	
CYLINDER HEAD ● Flatness 		LESS THAN 0.05 (0.002)	0.1 (0.004)
● Valve seat contact width 	IN. EX.	0.7 ~ 1.0 (0.028 ~ 0.039)	2.0 (0.079)
● Valve guide inside dia. 	EH12-2 EH17-2	5.500 ~ 5.518 (0.2165 ~ 0.2172)	5.65 (0.2224)
	EH25-2	6.035 ~ 6.053 (0.2376 ~ 0.2383)	6.15 (0.2421)

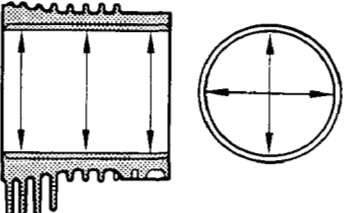
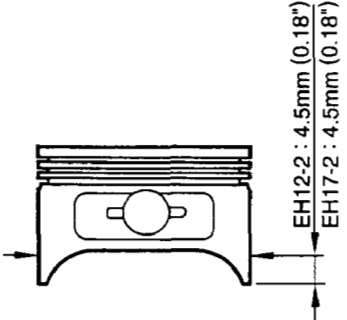
ITEM	EH12-2		EH17-2		
	STD	Lmit	STD	Lmit	
CYLINDER ● Inside dia. 	STD	60.000 ~ 60.019 (2.3622 ~ 2.3630)	To be rebored when the difference between max. and min. of diameter reached to 0.1 (0.004).	67.000 ~ 67.019 (2.6378 ~ 2.6385)	To be rebored when the difference between max. and min. of diameter reached to 0.1 (0.004).
	1st reboring	60.250 ~ 60.269 (2.3720 ~ 2.3728)	Ditto	67.250 ~ 67.269 (2.6476 ~ 2.6484)	Ditto
	2nd reboring	60.500 ~ 60.519 (2.3819 ~ 2.3826)	—	67.500 ~ 67.519 (2.6575 ~ 2.6582)	—
	● Roundness after reboring.	LESS THAN 0.01 (0.004)	—	LESS THAN 0.01 (0.004)	—
	● Cylindricity after reboring.	LESS THAN 0.015 (0.0006)	—	LESS THAN 0.015 (0.0006)	—
PISTON ● Piston size (At skirt in thrust direction) 	STD	59.96 ~ 59.98 (2.3606 ~ 2.3614)	59.87 (2.3571)	66.98 ~ 67.00 (2.6370 ~ 2.6378)	66.89 (2.6335)
	1st o/s	60.21 ~ 60.23 (2.3705 ~ 2.3713)	60.12 (2.3669)	67.23 ~ 67.25 (2.6469 ~ 2.6476)	67.14 (2.6433)
	2nd o/s	60.46 ~ 60.48 (2.3803 ~ 2.3811)	60.37 (2.3768)	67.48 ~ 67.50 (2.6567 ~ 2.6575)	67.39 (2.6531)

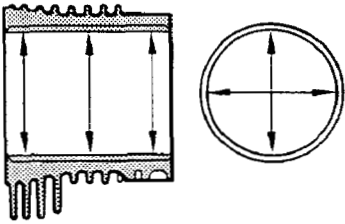
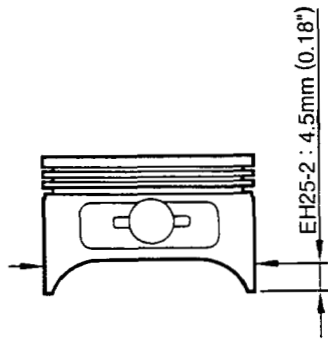

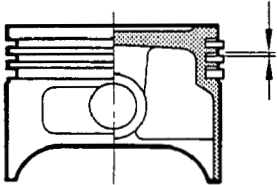
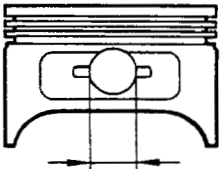
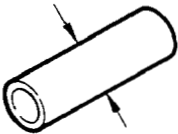
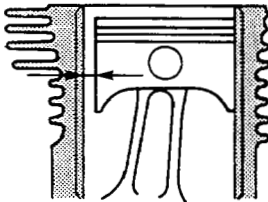
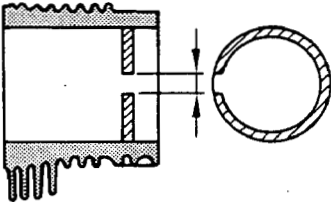
ITEM	EH25-2		
	STD	Lmit	
CYLINDER ● Inside dia.  ● Roundness after re boring. ● Cylindricity after re boring.	STD	75.000 ~ 75.019 (2.9528 ~ 2.9535)	To be re bored when the difference between max. and min. of diameter reached to 0.1 (0.004).
	1st re boring	75.250 ~ 75.269 (2.9626 ~ 2.9633)	Ditto
	2nd re boring	75.500 ~ 75.519 (2.9724 ~ 2.9732)	—
		LESS THAN 0.01 (0.004)	—
		LESS THAN 0.015 (0.0006)	—
PISTON ● Piston size (At skirt in thrust direction) 	STD	74.98 ~ 75.00 (2.9520 ~ 2.9528)	74.89 (2.9484)
	1st o/s	75.23 ~ 75.25 (2.9618 ~ 2.9626)	75.14 (2.9583)
	2nd o/s	75.48 ~ 75.50 (2.9717 ~ 2.9724)	75.39 (2.9681)

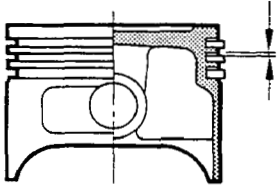
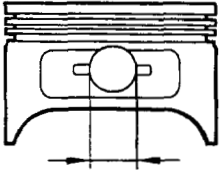
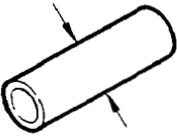
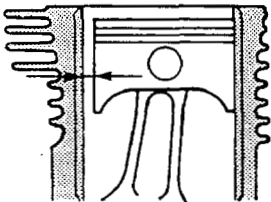
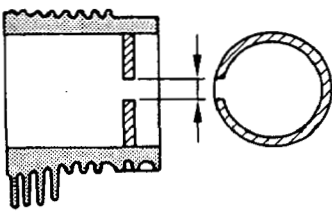
ITEM	EH12-2		EH17-2		
	STD	Limit	STD	Limit	
● Ring groove side clearance 	Top	0.030 ~ 0.075 (0.0012 ~ 0.0030)	0.15 (0.006)	0.035 ~ 0.080 (0.0014 ~ 0.0031)	0.15 (0.006)
	2nd	0.030 ~ 0.075 (0.0012 ~ 0.0030)	0.15 (0.006)	0.025 ~ 0.070 (0.0010 ~ 0.0028)	0.15 (0.006)
	Oil ring	0.020 ~ 0.075 (0.0008 ~ 0.0030)	0.15 (0.006)	0.010 ~ 0.065 (0.0004 ~ 0.0026)	0.15 (0.006)
● Piston pin hole 		12.991 ~ 13.002 (0.5115 ~ 0.5119)	13.035 (0.5132)	15.991 ~ 16.002 (0.6296 ~ 0.6300)	16.035 (0.6313)
● Piston pin outside dia. 		12.992 ~ 13.000 (0.5115 ~ 0.5118)	12.960 (0.5102)	15.992 ~ 16.000 (0.6296 ~ 0.6299)	15.960 (0.6284)
● Clearance between piston and cylinder at skirt area. 		0.015 ~ 0.074 (0.0006 ~ 0.0029)	0.25 (0.010)	0.015 ~ 0.074 (0.0006 ~ 0.0029)	0.25 (0.010)
● Piston ring end gap 	Top 2nd	0.2 ~ 0.4 (0.008 ~ 0.016)	1.5 (0.0591)	0.2 ~ 0.4 (0.008 ~ 0.016)	1.5 (0.0091)
	oil ring	0.2 ~ 0.4 (0.008 ~ 0.016)	1.5 (0.0591)	0.05 ~ 0.25 (0.0002 ~ 0.010)	1.5 (0.0591)

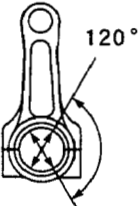
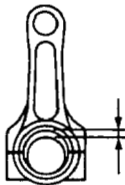
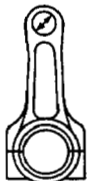
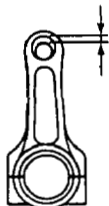
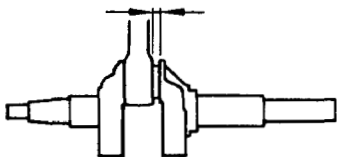
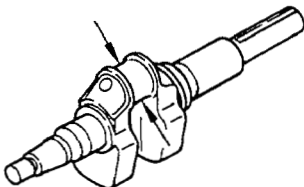
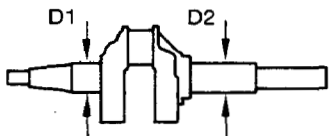
ITEM	EH25-2		
	STD	Limit	
● Ring groove side clearance 	Top	0.050 ~ 0.090 (0.0020 ~ 0.0035)	0.15 (0.006)
	2nd	0.030 ~ 0.070 (0.0012 ~ 0.0028)	0.15 (0.006)
	Oil ring	0.010 ~ 0.065 (0.0004 ~ 0.0026)	0.15 (0.006)
● Piston pin hole 		17.991 ~ 18.002 (0.7083 ~ 0.7087)	18.035 (0.7100)
● Piston pin outside dia. 		17.992 ~ 18.000 (0.7084 ~ 0.7087)	17.960 (0.7071)
● Clearance between piston and cylinder at skirt area. 		0.025 ~ 0.064 (0.0001 ~ 0.0025)	0.25 (0.010)
● Piston ring end gap 	Top 2nd	0.1 ~ 0.3 (0.004 ~ 0.012)	1.5 (0.0591)
	oil ring	0.1 ~ 0.3 (0.004 ~ 0.012)	1.5 (0.0591)

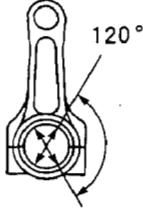
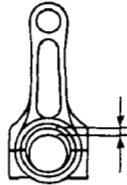
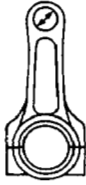
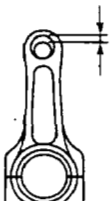
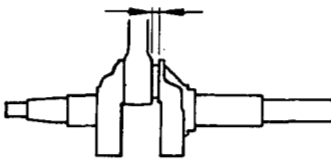
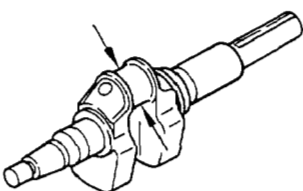
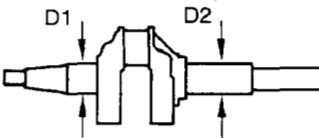
ITEM	EH12-2	
	STD	Limit
CONNECTING ROD <ul style="list-style-type: none"> ● Big end inside dia. 	26.000 ~ 26.013 (1.0236 ~ 1.0241)	26.1 (1.0276)
<ul style="list-style-type: none"> ● Clearance between big end and crankpin 	0.020 ~ 0.046 (0.0008 ~ 0.0018)	0.2 (0.008)
<ul style="list-style-type: none"> ● Small end inside dia. 	13.010 ~ 13.021 (0.5122 ~ 0.5126)	13.08 (0.5150)
<ul style="list-style-type: none"> ● Clearance between small end and piston pin 	0.010 ~ 0.029 (0.0004 ~ 0.0011)	0.12 (0.0047)
<ul style="list-style-type: none"> ● Big end side clearance 	0.1 ~ 0.7 (0.004 ~ 0.028)	1.0 (0.040)
CRANKSHAFT <ul style="list-style-type: none"> ● Crankpin outside dia. 	25.967 ~ 25.980 (1.0223 ~ 1.0228)	25.85 (1.0177)
<ul style="list-style-type: none"> ● Journal dia. 	D1, D2 24.988 ~ 24.997 (0.9839 ~ 0.9841)	

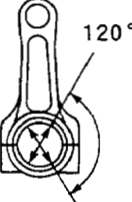
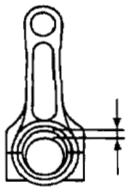
ITEM	EH17-2	
	STD	Limit
CONNECTING ROD ● Big end inside dia. 	30.000 ~ 30.016 (1.1811 ~ 1.1817)	30.1 (1.1850)
● Clearance between big end and crankpin 	0.020 ~ 0.049 (0.0008 ~ 0.0019)	0.2 (0.008)
● Small end inside dia. 	16.010 ~ 16.021 (0.6303 ~ 0.6308)	16.08 (06331)
● Clearance between small end and piston pin 	0.010 ~ 0.029 (0.0004 ~ 0.0011)	0.12 (0.0047)
● Big end side clearance 	0.1 ~ 0.7 (0.004 ~ 0.028)	1.0 (0.040)
CRANKSHAFT ● Crankpin outside dia. 	29.967 ~ 29.980 (1.1798 ~ 1.1803)	29.85 (1.1752)
● Journal dia. 	D1, D2 24.988 ~ 24.997 (0.9838 ~ 0.9841)	

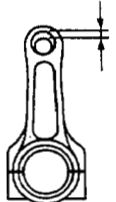
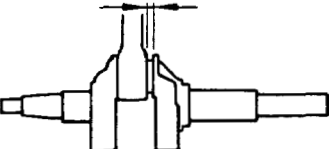
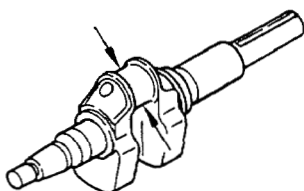
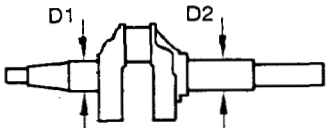
ITEM	EH25-2							
	STD	Limit						
CONNECTING ROD ● Big end inside dia.  ● Clearance between big end and crankpin  ● Small end inside dia.  ● Clearance between small end and piston pin  ● Big end side clearance 	34.000 ~ 34.016 (1.3386 ~ 1.3392)	34.10 (1.3425)						
	0.025 ~ 0.057 (0.0010 ~ 0.0022)	0.2 (0.008)						
	18.010 ~ 18.021 (0.7091 ~ 0.7095)	18.08 (0.7118)						
	0.010 ~ 0.029 (0.0004 ~ 0.0011)	0.12 (0.0047)						
	0.1 ~ 0.7 (0.004 ~ 0.028)	1.0 (0.040)						
CRANKSHAFT ● Crankpin outside dia. 	33.959 ~ 33.975 (1.3370 ~ 1.3376)	33.85 (1.3327)						
● Journal dia. 	<table border="1"> <thead> <tr> <th>D1</th> <th>D2</th> </tr> </thead> <tbody> <tr> <td> D TYPE 29.991 ~ 30.000 (1.1807 ~1.1811) </td> <td> 29.988 ~ 29.997 (1.1806 ~1.1810) </td> </tr> <tr> <td> B TYPE 27.991 ~ 30.000 (1.1807 ~1.1811) </td> <td> 27.988 ~ 27.997 (1.1019 ~1.1022) </td> </tr> </tbody> </table>	D1	D2	D TYPE 29.991 ~ 30.000 (1.1807 ~1.1811)	29.988 ~ 29.997 (1.1806 ~1.1810)	B TYPE 27.991 ~ 30.000 (1.1807 ~1.1811)	27.988 ~ 27.997 (1.1019 ~1.1022)	
D1	D2							
D TYPE 29.991 ~ 30.000 (1.1807 ~1.1811)	29.988 ~ 29.997 (1.1806 ~1.1810)							
B TYPE 27.991 ~ 30.000 (1.1807 ~1.1811)	27.988 ~ 27.997 (1.1019 ~1.1022)							

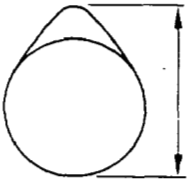
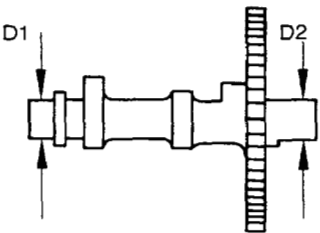
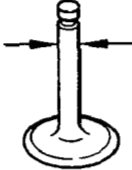
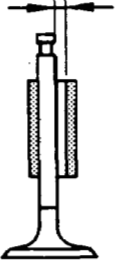
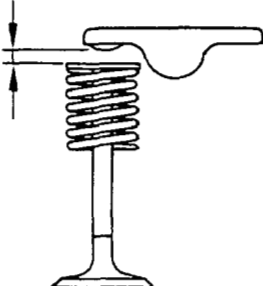
ITEM	EH12-2 / EH17-2		
	STD	Limit	
CAMSHAFT ● Cam height  ● Journal outside dia. "D" type 	IN.EX. CAMS	29.6 ~ 29.8 (1.165 ~ 1.173)	29.45 (1.159)
	D1	16.973 ~ 16.984 (0.6682 ~ 0.6687)	16.95 (0.6673)
	D2	14.973 ~ 14.984 (0.5895 ~ 0.5899)	14.95 (0.5886)
VALVE ● Valve stem outside dia.  ● Clearance between valve stem dia. and valve guide  ● Valve clearance 	IN.	5.440 ~ 5.455 (0.2142 ~ 0.2148)	5.35 (0.2106)
	EX.	5.426 ~ 5.444 (0.2136 ~ 0.2143)	5.35 (0.2106)
	IN.	0.045 ~ 0.078 (0.0018 ~ 0.0031)	0.3 (0.012)
	EX.	0.056 ~ 0.092 (0.0022 ~ 0.0036)	0.3 (0.012)
	IN./EX. (cold)	0.08 ~ 0.12 (0.0031 ~ 0.0047)	

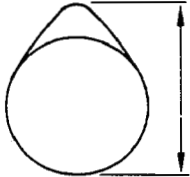
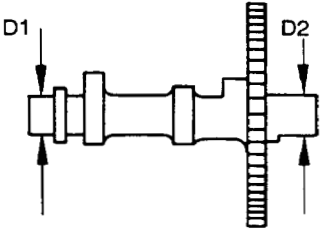
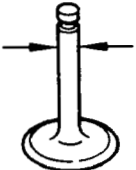
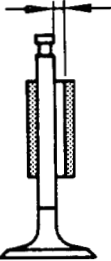
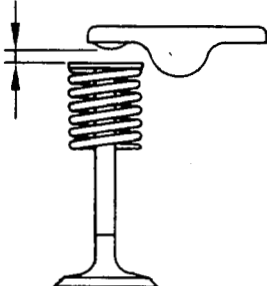
ITEM	EH25-2		
	STD	Limit	
CAMSHAFT ● Cam height  ● Journal outside dia. "D" type 	IN.EX. CAMS	30.6 ~ 30.8 (1.205 ~ 1.213)	30.45 (1.199)
	D1	24.967 ~ 24.980 (0.9830 ~ 0.9835)	24.95 (0.9823)
	D2	14.973 ~ 14.984 (0.5895 ~ 0.5899)	14.95 (0.5886)
VALVE ● Valve stem outside dia.  ● Clearance between valve stem dia. and valve guide  ● Valve clearance 	IN.	5.975 ~ 5.990 (0.2352 ~ 0.2358)	5.85 (0.2303)
	EX.	5.960 ~ 5.975 (0.2346 ~ 0.2352)	5.85 (0.2303)
	IN.	0.045 ~ 0.078 (0.0018 ~ 0.0031)	0.3 (0.012)
	EX.	0.060 ~ 0.093 (0.0024 ~ 0.0037)	0.3 (0.012)
	IN./EX. (cold)	0.08 ~ 0.12 (0.0031 ~ 0.0047)	

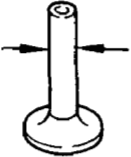
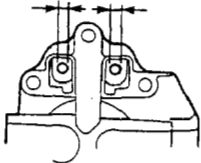
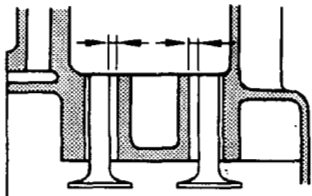
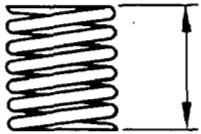
ITEM	EH12-2/EH17-2	
	STD	Limit
TAPPET ● Stem outside dia. 	7.960 ~ 7.975 (0.3134 ~ 0.3140)	
● Guide inside dia. 	8.000 ~ 8.015 (0.3150 ~ 0.3156)	
● Tappet guide clearance 	0.025 ~ 0.055 (0.0010 ~ 0.0022)	
VALVE SPRING FREE LENGTH 	30.5 (1.2)	—

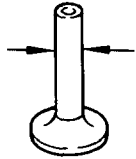
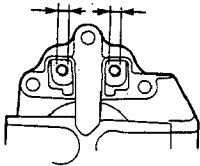
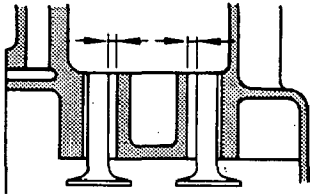
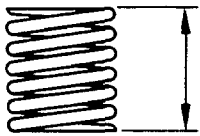
ITEM	EH25-2	
	STD	Limit
TAPPET ● Stem outside dia. 	7.960 ~ 7.975 (0.3134 ~ 0.3140)	
● Guide inside dia. 	8.000 ~ 8.015 (0.3150 ~ 0.3156)	
● Tappet guide clearance 	0.025 ~ 0.055 (0.0010 ~ 0.0022)	
VALVE SPRING FREE LENGTH 	35.5 (1.4)	—————

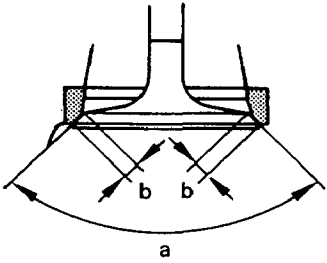
ITEM	EH12-2 / 17-2 / 25-2	
	STD	Limit
VALVE SEAT ANGLE(IN. EX.) ● Valve cutter angle(a) ● Valve contact width(b) 	a: 90° b: 0.7 ~ 1.0 (0.028 ~ 0.039)	2.0 (0.079)

12-2 TORQUE SPECIFICATIONS

EH12-2/17-2 type

DESCRIPTION		TIGHTENING TORQUE					
		N•m		kg•cm		ft•lb	
Cylinder head bolts		22.5 ~ 26.5		230 ~ 270		16.6 ~ 19.5	
Connecting rod cap bolts		EH12-2 8.8 ~ 11.2	EH17-2 16.6 ~ 19.6	EH12-2 90 ~ 115	EH17-2 170 ~ 200	EH12-2 6.5 ~ 8.3	EH17-2 12.2 ~ 14.4
Flywheel nut		58.8 ~ 63.7		600 ~ 650		43 ~ 47	
Main bearing cover bolts		7.8 ~ 9.8		80 ~ 100		5.7 ~ 7.2	
Spark plug	New spark plug	11.8 ~ 14.7		120 ~ 150		8.7 ~ 10.9	
	Retightening	22.6 ~ 26.5		230 ~ 270		16.6 ~ 19.5	

EH25-2 type

DESCRIPTION		TIGHTENING TORQUE					
		N•m		kg•cm		ft•lb	
Cylinder head bolts		33.3 ~ 41.2		340 ~ 420		24.6 ~ 30.3	
Connecting rod cap bolts		21.3 ~ 26.9		225 ~ 275		16.3 ~ 19.8	
Flywheel nut		58.8 ~ 63.7		600 ~ 650		43 ~ 47	
Main bearing cover bolts		16.7 ~ 18.6		170 ~ 190		12.3 ~ 13.7	
Spark plug	New spark plug	11.8 ~ 14.7		120 ~ 150		8.7 ~ 10.9	
	Retightening	22.6 ~ 26.5		230 ~ 270		16.6 ~ 19.5	

12-3 OIL GRADE CHART

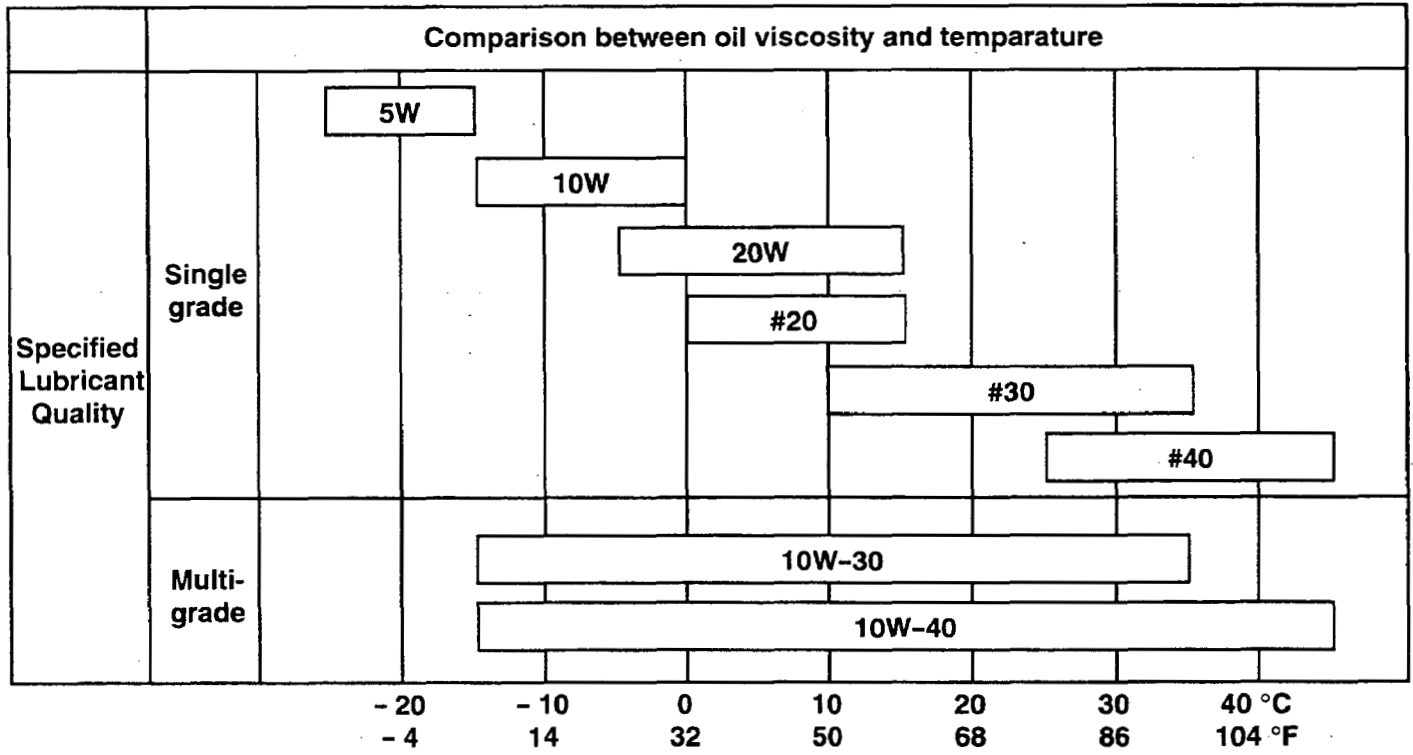

Use oil classified as SE or higher.

Multi-grade oil tends to increase its consumption at high ambient temperature.

13. MAINTENANCE AND STORAGE

The following maintenance jobs apply when the engine is operated correctly under normal conditions. The indicated maintenance intervals are by no means guarantees for maintenance free operations during these intervals.

For example, if the engine is operated in extremely dusty conditions, the air cleaner should be cleaned every day instead of every 50 hours.

13-1 DAILY MAINTENANCE

MAINTENANCE	REMARKS
1) Clean away dust and chaff from engine.	Governor linkage is especially sensitive to dust.
2) Check fuel leakage from fuel system. If any, retighten fasteners or replace necessary parts.	
3) Inspect for loose hardwares and retighten if necessary.	Loose bolts and nuts may come off and result in breakage of other parts.
4) Check oil level and add to full mark.	

13-2 INITIAL 20 HRS. MAINTENANCE

MAINTENANCE	REMARKS
1) Change crankcase oil.	To remove sludge from run-in operation.

13-3 EVERY 50 HRS. (10 DAYS) MAINTENANCE

MAINTENANCE	REMARKS
1) Change crankcase oil.	Contaminated oil quickens wear.
2) Clean air cleaner.	
3) Check and clean spark plug.	If dirty, wash in gasoline or polish with emery paper.

13-4 EVERY 100~200 HRS. (MONTHLY) MAINTENANCE

MAINTENANCE	REMARKS
1) Clean fuel filter and fuel tank.	
2) Inspect cooling system and remove dirt and chaff.	Remove blower housing and clean up between fins and housing.

13-5 EVERY 500~600 HRS. MAINTENANCE

MAINTENANCE	REMARKS
1) Remove carbon from cylinder head.	Carbon deposits in combustion chamber causes lack of power.
2) Disassemble and clean carburetor.	

13-6 EVERY 1000 HRS. (YEARLY) MAINTENANCE

MAINTENANCE	REMARKS
1) Overhaul engine.	Clean and correct parts. Replace piston rings and other necessary parts.
2) Replace fuel lines once a year.	Avoid hazards caused by fuel leakage.

13-7 ENGINE STORAGE

- (1) Perform the above 13-1 and 13-2 maintenance jobs.
- (2) Drain fuel from the fuel tank and carburetor float chamber.
- (3) To prevent rust in the cylinder bore, apply oil through the spark plug hole and turn the crankshaft several turns by hand. Reinstall the plug.
- (4) Turn the starting pulley by hand and leave it where the resistance is the heaviest.
- (5) Clean outside of the engine with oiled cloth.
- (6) Put a plastic cover or the like over the engine and store the engine in dry place.



Robin

SUBARU

Industrial Engines

Robin America, Inc.

940 Lively Blvd. • Wood Dale, IL 60191 • Phone: 630-350-8200 • Fax: 630-350-8212
e-mail: sales@robinamerica.com • www.robinamerica.com

PRINTED IN THE USA

Robin America, Inc.