

OWNER'S MANUAL

LCD TV Monitor
15MF200V/37

MAGNAVOX
SMART. VERY SMART.



NEED HELP? CALL US!

MAGNAVOX REPRESENTATIVES ARE READY TO HELP YOU WITH ANY QUESTIONS ABOUT YOUR NEW PRODUCT. WE CAN GUIDE YOU THROUGH CONNECTIONS, FIRST-TIME SETUP, AND ANY OF THE FEATURES. WE WANT YOU TO START ENJOYING YOUR NEW PRODUCT RIGHT AWAY.

**CALL US BEFORE YOU CONSIDER RETURNING THE PRODUCT.
1-800-705-2000**

OR VISIT US ON THE WEB AT WWW.MAGNAVOX.COM

Important!
Return your Warranty Registration Card within 10 days.
See why inside.

Return your Warranty Registration card today to ensure you receive all the benefits you're entitled to.

Once your MAGNAVOX purchase is registered, you're eligible to receive all the privileges of owning a MAGNAVOX product. So complete and return the Warranty Registration Card enclosed with your purchase at once. And take advantage of these important benefits.

Warranty Verification

Registering your product within 10 days confirms your right to maximum protection under the terms and conditions of your MAGNAVOX warranty.

Owner Confirmation

Your completed Warranty Registration Card serves as verification of ownership in the event of product theft or loss.

Model Registration

Returning your Warranty Registration Card right away guarantees you'll receive all the information and special offers which you qualify for as the owner of your model.

Congratulations on your purchase, and welcome to the "family!"



Dear MAGNAVOX product owner:

Thank you for your confidence in MAGNAVOX. You've selected one of the best-built, best-backed products available today. We'll do everything in our power to keep you happy with your purchase for many years to come.

As a member of the MAGNAVOX "family," you're entitled to protection by one of the most comprehensive warranties and outstanding service networks in the industry.

What's more, your purchase guarantees you'll receive all the information and special offers for which you qualify, plus easy access to accessories from our convenient home shopping network. Most importantly, you can count on our uncompromising commitment to your total satisfaction.

All of this is our way of saying welcome-and thanks for investing in a MAGNAVOX product.

P.S. Remember, to get the most from your MAGNAVOX product, you must return your Warranty Registration Card within 10 days. So please mail it to us right now!

Know these safety symbols



⚡ This "bolt of lightning" indicates uninsulated material within your unit may cause an electrical shock. For the safety of everyone in your household, please do not remove product covering.

⚠ The "exclamation point" calls attention to features for which you should read the enclosed literature closely to prevent operating and maintenance problems.

WARNING: TO PREVENT FIRE OR SHOCK HAZARD, DO NOT EXPOSE THIS EQUIPMENT TO RAIN OR MOISTURE.

CAUTION: To prevent electric shock, match wide blade of plug to wide slot, fully insert.

ATTENTION: Pour éviter les choc électriques, introduire la lame la plus large de la fiche dans la borne correspondante de la prise et pousser jusqu'au fond.

For Customer Use

Enter below the Serial No. which is located on the rear of the cabinet. Retain this information for future reference.

Model No. _____
Serial No. _____

Visit our World Wide Web Site at <http://www.magnavox.com>

IMPORTANT SAFETY INSTRUCTIONS

Read before operating equipment

1. Read these instructions.
2. Keep these instructions.
3. Heed all warnings.
4. Follow all instructions.
5. Do not use this apparatus near water.
6. Clean only with a dry cloth.
7. Do not block any of the ventilation openings. Install in accordance with the manufacturer's instructions.
8. Do not install near any heat sources such as radiators, heat registers, stoves, or other apparatus (including amplifiers) that produce heat.
9. Do not defeat the safety purpose of the polarized or grounding-type plug. A polarized plug has two blades with one wider than the other. A grounding type plug has two blades and a third grounding prong. The wide blade or third prong are provided for your safety. When the provided plug does not fit into your outlet, consult an electrician for replacement of the obsolete outlet.
10. Protect the power cord from being walked on or pinched, particularly at plugs, convenience receptacles, and the point where they exit from the apparatus.
11. Only use attachments/accessories specified by the manufacturer.
12.  Use only with a cart, stand, tripod, bracket, or table specified by the manufacturer or sold with the apparatus. When a cart is used, use caution when moving the cart/apparatus combination to avoid injury from tip-over.
13. Unplug this apparatus during lightning storms or when unused for long periods of time.
14. Refer all servicing to qualified service personnel. Servicing is required when the apparatus has been damaged in any way, such as if the power-supply cord or plug is damaged, liquid has been spilled or objects have fallen into the apparatus, or if the apparatus has been exposed to rain or moisture, does not operate normally, or has been dropped.
15. This product may contain lead and mercury. Disposal of these materials may be regulated due to environmental considerations. For disposal or recycling information, please contact your local authorities or the Electronic Industries Alliance (www.eiae.org).
16. **Damage Requiring Service** - The appliance should be serviced by qualified service personnel when:
 - A. The power supply cord or the plug has been damaged;

- B. Objects have fallen or liquid has been spilled into the appliance;
 - C. The appliance has been exposed to rain;
 - D. The appliance does not appear to operate normally or exhibits a marked change in performance;
 - E. The appliance has been dropped or the enclosure damaged.
- 17. Tilt/Stability** - All televisions must comply with recommended international global safety standards for tilt and stability properties of its cabinet design.
- Do not compromise these design standards by applying excessive pull force to the front, or top, of the cabinet, which could ultimately overturn the product.
 - Also, do not endanger yourself, or children, by placing electronic equipment/toys on the top of the cabinet. Such items could unsuspectingly fall from the top of the set and cause product damage and/or personal injury.
- 18. Wall or Ceiling Mounting** - The appliance should be mounted to a wall or ceiling only as recommended by the manufacturer.
- 19. Power Lines** - An outdoor antenna should be located away from power lines.
- 20. Outdoor Antenna Grounding** - If an outside antenna is connected to the receiver, be sure the antenna system is grounded so as to provide some protection against voltage surges and built up static charges. Section 810 of the National Electrical Code, ANSI/NFPA No. 70-1984, provides information with respect to proper grounding of the mast and supporting structure, grounding of the lead-in wire to an antenna discharge unit, size of grounding connectors, location of antenna-discharge unit, connection to grounding electrodes, and requirements for the grounding electrode. See Figure below.
- 21. Object and Liquid Entry** - Care should be taken so that objects do not fall and liquids are not spilled into the enclosure through openings.
- 22. Battery usage CAUTION** - To prevent battery leakage that may result in bodily injury, property damage, or damage to the unit:
- Install all batteries correctly, with + and - aligned as marked on the unit.
 - Do not mix batteries (old and new or carbon and alkaline, etc.).
 - Remove batteries when the unit is not used for a long time.

Note to the Cable TV system installer: This reminder is provided to call the Cable TV system installer's attention to Article 820-40 of the NEC that provides guidelines for proper grounding and, in particular, specifies that the cable ground shall be connected to the grounding system of the building, as close to the point of cable entry as practical.

Example of Antenna Grounding as per NEC - National Electrical Code

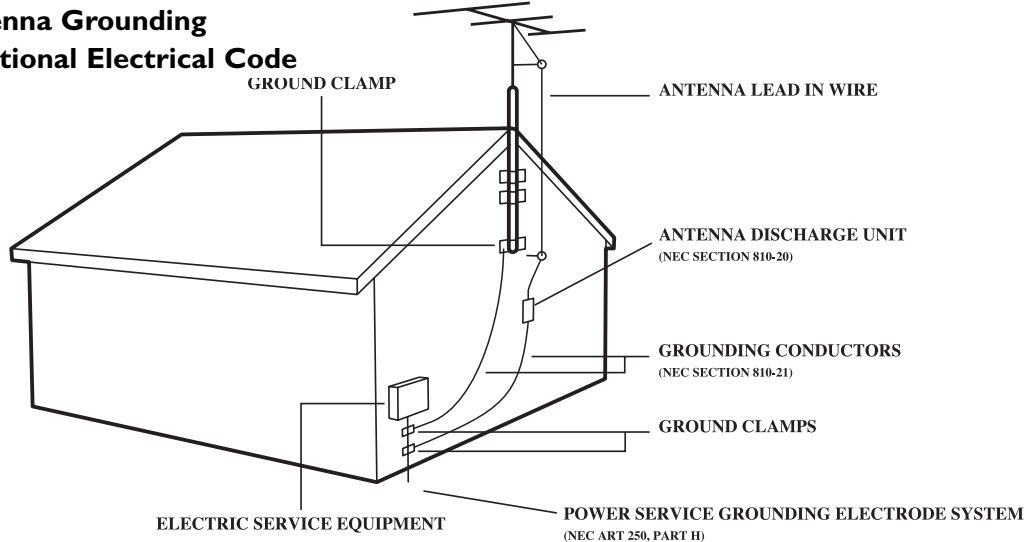

CONTENTS

Introduction

Welcome/Registration of Your TV	2
Safety Instructions	3
Table of Contents	4

Getting Started

Basic TV and Remote Control Operations	5
Description of Remote Control Buttons	6
Antenna Connection	7
Basic Cable TV Connection	7
Cable Box Connections	8
Using the Audio/Video Input Connections	9
S-Video Jack Connections	10
PC (Monitor) Connections	11

Install Menu

 How to use the Tuner Mode Control	12
How to Auto Program TV Channels	13
How to Add or Delete Channels (Store)	14
How to use SmartSurf (Alternate Channel)	15
Fine Tune	16

Picture Menu

How to use the Picture Adjustment Controls	17
--	----

Sound Menu

How to use the Sound Adjustment Controls	18
--	----

Features Menu

Understanding the SmartLock™ Controls	19
Setting up the SmartLock™ Access Code	20
How to Block Channels	21
Blocking Programming Based on Movie Ratings	22
Blocking Programming Based on TV Ratings	23
Setting the Sleptimer Control	24
How to use the Closed Captioning Control	25
Freeze	26
How to use the Language Control	27
Resetting the Factory Settings	28

PC Mode

PC Picture	29
PC Image Adjustments	30
PC Sound Adjustments	31
PC Color Adjustments	32
PC Feature Controls	33
Setting Up the PC Mode	34

General Information

Troubleshooting Tips	35
Care and Cleaning	36
Index	37
Factory Service Locations	38-39
Limited Warranty	40

Here are a few of the special features of your new LCD Monitor.

Audio/Video In Jacks: Use to quickly connect other equipment to your LCD TV Monitor.

Automatic Channel Programming (Auto Program): Quick and easy setup of available channels.

Closed Captioning: Allows the viewer to read TV program dialog or voice conversations as on-screen text.

On-screen Menus: Helpful messages (in English or Spanish) for setting TV controls.

Remote Control: Works your LCD TV Monitor features.

Sleep Timer: Turns off the LCD TV Monitor within an amount of time you specify (30-120 minutes from the current time).

SmartLock™: Lets you block viewing of certain TV channels if you do not want your children viewing inappropriate material.

Standard broadcast (VHF/UHF) or Cable TV channel capability

Stereo capability: Includes a built-in amplifier and twin-speaker system, allowing reception of TV programs broadcast in stereo.

Treble, Bass, and Balance: Enhance the LCD TV Monitor's sound.

NOTE: This manual covers different versions and models. Not all features described in this manual will match those of your LCD TV Monitor. This is normal and does not require you contacting your dealer or requesting service.

END-OF-LIFE DISPOSAL

Your new LCD TV Monitor and its packaging contain materials that can be recycled and reused. Specialized companies can recycle your product to increase the amount of reusable materials and minimize the amounts that need to be properly disposed.

Your product also uses batteries that should not be thrown away when depleted, but should be handed in and disposed of as small chemical waste.

When you replace your existing equipment, please find out about the local regulations regarding disposal of your old television, batteries, and packing materials.

SmartLock™ is a registered trademarks of Philips Consumer Electronics North America.

Copyright © 2003 Magnavox. All rights reserved.



TELEVISION

- 1** Press **POWER**  to turn on the LCD TV Monitor.
- 2** Press **VOLUME +** to increase the sound level. **Or, press VOLUME -** to lower the sound level.
- 3** Press **CH▶** or **CH◀** to select channels.

REMOTE CONTROL

- 4** Point the remote control toward the remote sensor on the front of the LCD TV Monitor when operating the LCD TV Monitor with the remote.

BATTERY INSTALLATION

- 5** Remove the battery compartment lid on the back of the remote.
- 6** Place two **AAA** batteries in the remote. Be sure the (+) and (-) ends of the batteries line up as marked inside the battery compartment.
- 7** Reattach the battery compartment lid.

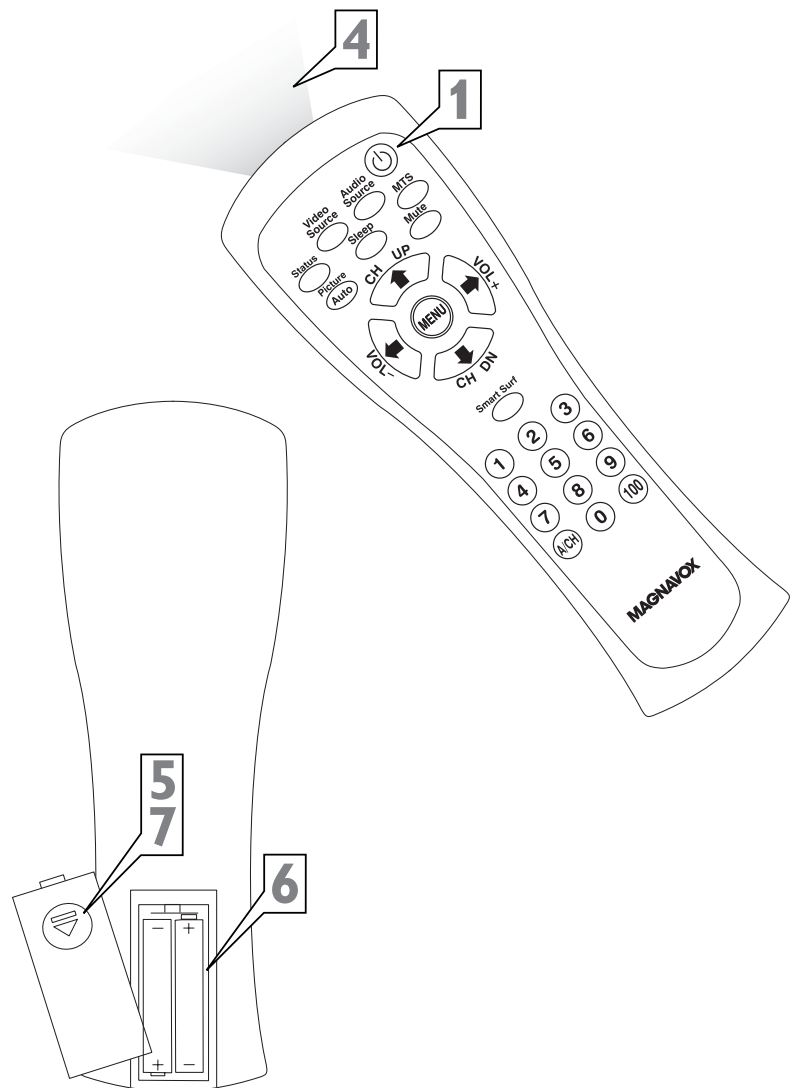
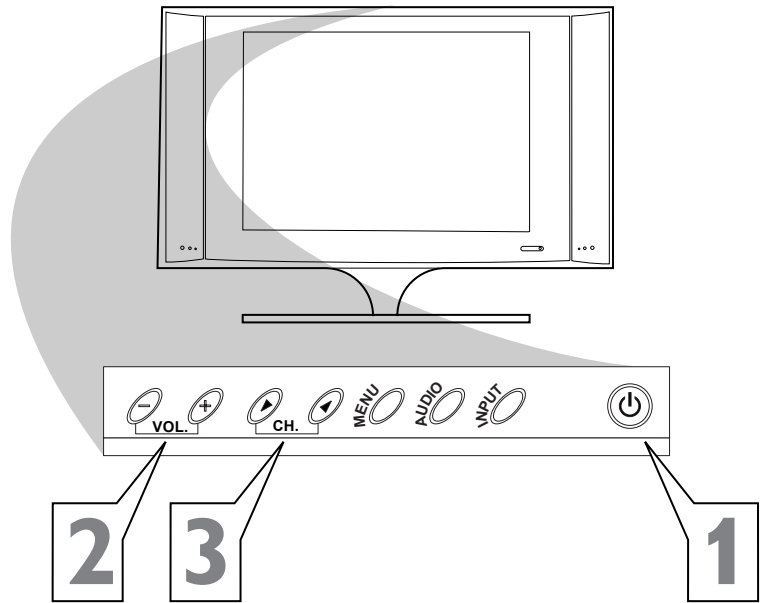



REMOTE CONTROL

Video Source button

Press to select the video input source: PC/Video/TV.

Sleep button

Press to set the LCD TV Monitor to turn itself off within a certain time. Details are on page 23.

Status button

Press to display the current system status (ie, channel).

Picture button

Press to Auto adjust the PC function. Details are on page 27. Also press this button to adjust some of the LCD TV Monitor picture menu items.

Menu button

Press to see the menu. Also press to exit the onscreen menu.

VOL(ume) - button

Press to decrease the sound. Also press to select or adjust items in the menu.

CH(annel) DN button

Press to adjust the channel down. Also press to select or adjust items in the menu.

Number buttons

Press to select TV channels. When selecting single-digit channels, press the number of the desired channel. The LCD TV Monitor will pause for a few seconds then tune to the selected channel.

A/CH button

Press to alternate from current channel selection to previous channel selection.

Audio Source button

Press to select the video input source: PC/AV/TV.

Standby (Power) button

Press to turn the LCD TV Monitor) on or off.

MTS Button

Press to select a sound mode if available with the TV programming: Mono, Stereo, or SAP. Details on page 17.

Mute button

Press to eliminate or restore the LCD TV Monitor sound. Mute on will appear on the screen when the sound is muted.

CH(annel) UP button

Press to adjust the channel up. Also press to select or adjust items in the menu.

VOL(ume)+ button

Press to increase the sound. Also press to select or adjust items in the menu.

Smart Surf Button

Press to store your favorite channel. Details on page 15.

100 Button

Press to select the channel from 100 to 125.

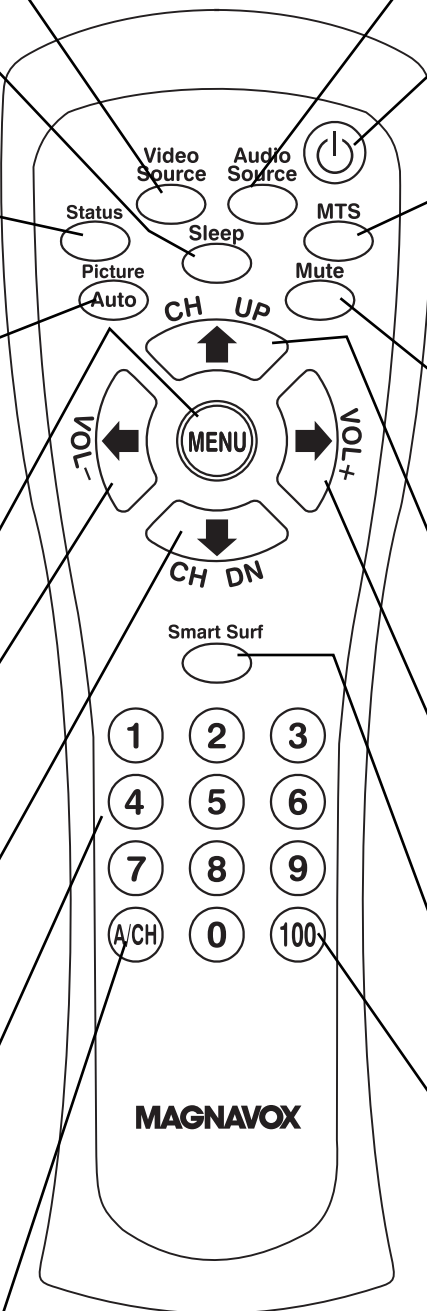

ANTENNA CONNECTION

A combination antenna receives normal broadcast channels (VHF 2–13 and UHF 14–69). Your connection is easy because there is only one 75Ω (ohm) antenna jack on the back of your TV, and that's where the antenna goes.

- 1** If your antenna has a round cable (75 ohm) on the end, then you're ready to connect it to the LCD TV Monitor. If your antenna has flat, twin-lead wire (300 ohm), you first need to attach the antenna wires to the screws on a 300- to 75-ohm adapter.
- 2** Connect the antenna (or adapter) to the TV jack on the rear of the LCD TV Monitor. If the end of the antenna wire is threaded, screw it down finger tight.

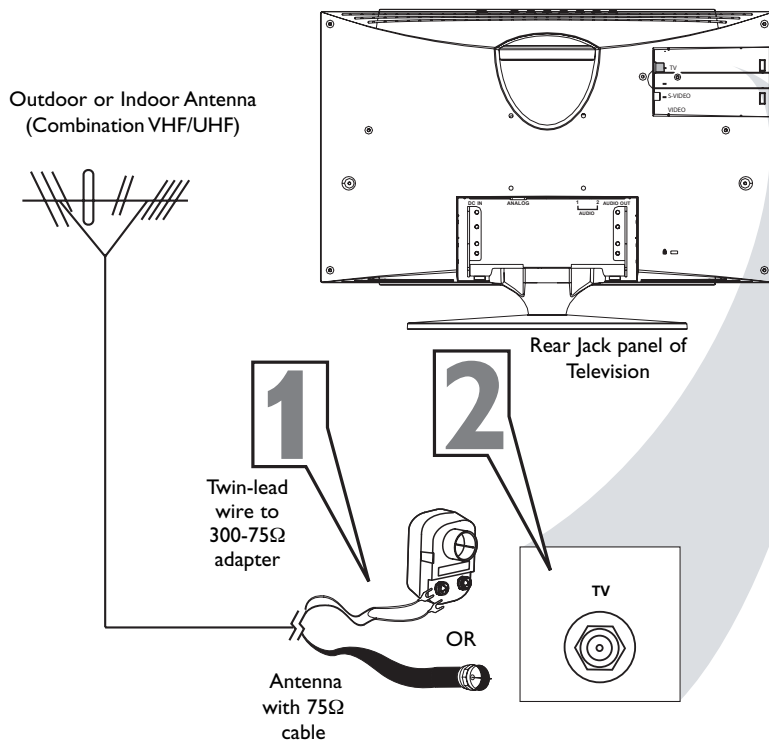

BASIC CABLE TV CONNECTION

Your Cable TV signal into your home may be a single, 75Ω (ohm) cable. If so, this connection is very simple. Follow the step below to connect your Cable TV signal to your new LCD TV Monitor.

- 1** Connect the Cable TV signal to the TV jack on the LCD TV Monitor. Screw it down finger tight.

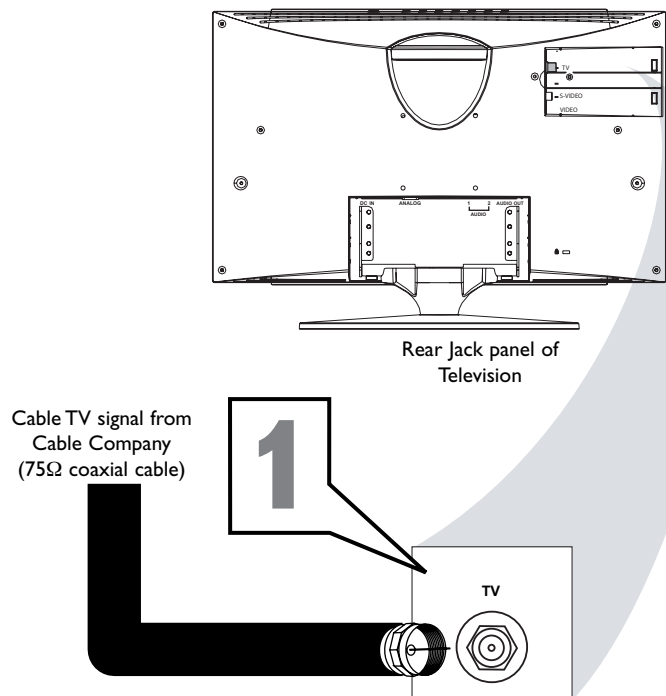



CABLE BOX CONNECTIONS

If you have a Cable Box, follow either set of these steps to complete your connections.

Cable Box with RF In/Out Jacks

This connection will not supply Stereo sound to the LCD TV Monitor. The sound from the Cable Box will be monaural (single-channel, not left and right).

- 1** Connect the Cable TV signal to the **IN** jack (or RF IN or CABLE IN) on the Cable Box.
- 2** Connect an RF coaxial cable (not supplied) to the **OUT** jack (or TO TV or RF OUT) of the Cable Box.
- 3** Connect the other end of the coaxial cable to the LCD TV Monitor's TV jack. Screw it down finger tight.
- 4** Set the Channel 3/4 (or Output channel) switch of the Cable Box to 3 or 4. Set the TV to the same channel. When watching TV programming, change channels at the Cable Box, not the LCD TV Monitor.

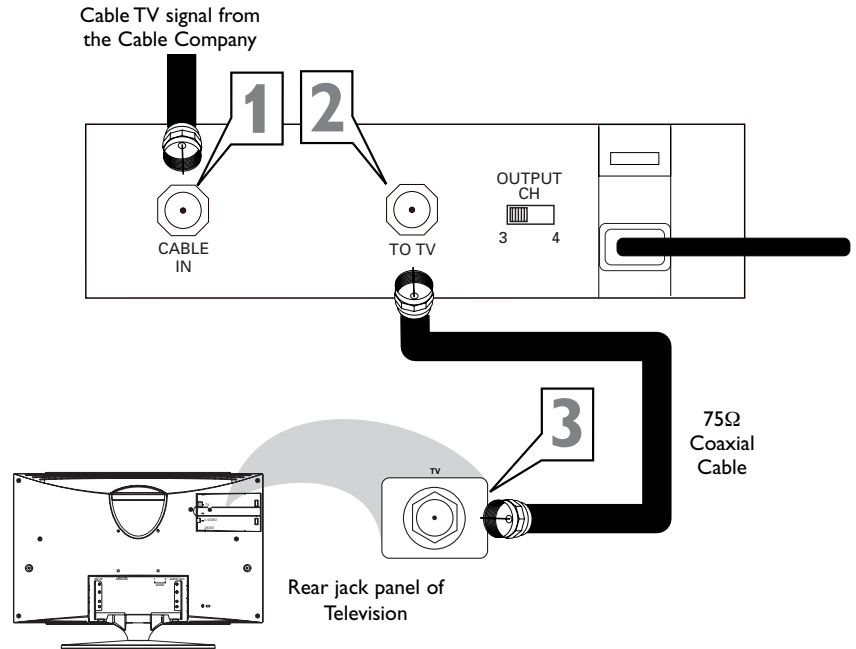

Cable Box with Audio/Video Out Jacks

This connection will supply Stereo sound to the LCD TV Monitor.

- 1** Connect the Cable TV signal to the **IN** jack (or RF IN or CABLE IN) on the Cable Box.
- 2** Using an RCA-type video cable, connect one end of the video cable to the **Video Out** jack of the Cable Box. Connect the other end of the cable to the **yellow VIDEO** jack on the rear of the TV.
- 3** Using RCA-type, stereo audio cables, connect one end of the cables to the **left and right Audio Out** jacks of the Cable Box. Connect the other end of the cables to the **red and white AUDIO** ends of the audio cable supplied. Connect the other end of that cable to the **Audio 2** jack on the rear of the LCD TV Monitor.
- 4** Plug the DC adapter into the **DC IN** jack on the LCD TV Monitor. Plug the power cable into an outlet. Press the **Video Source** button for the source you are using.

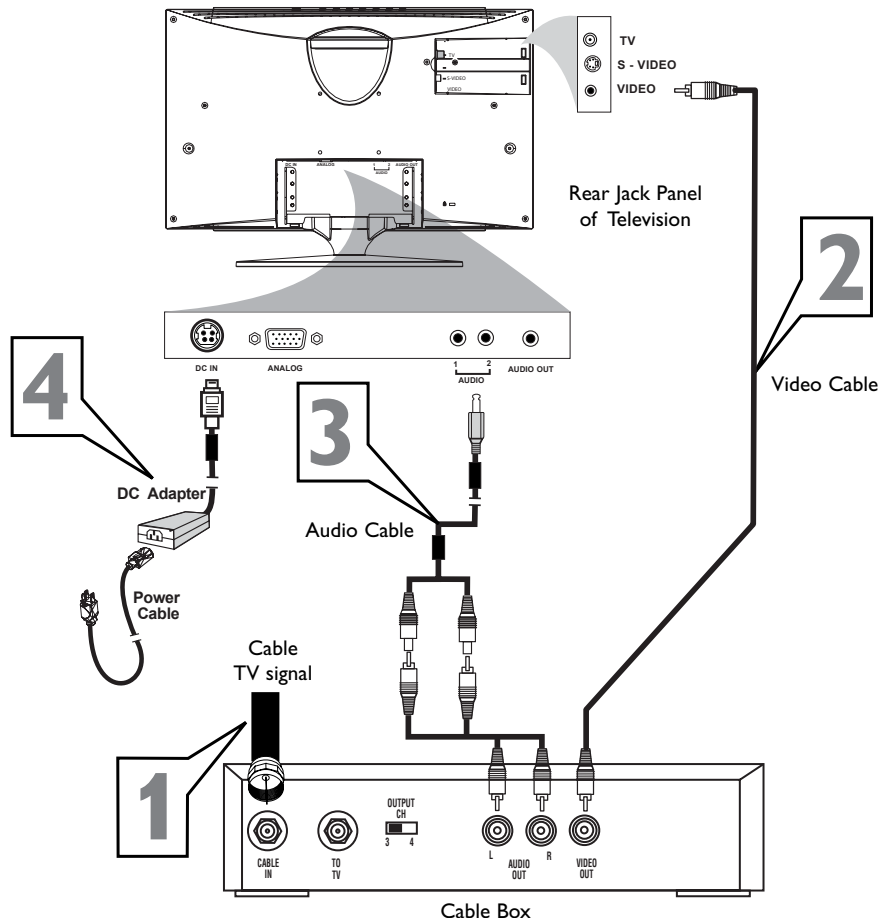

AUDIO/VIDEO INPUT CONNECTIONS



The **AUDIO** and **VIDEO** In jacks on the rear of the LCD TV Monitor enable quick connections of other equipment. Connect a VCR, DVD Player, Video Game, Camcorder, etc., to these jacks. To view the material playing on the other equipment, set the LCD TV Monitor to its **VIDEO** input channel.

1 Connect an **RCA-style video cable (usually yellow)** to the **VIDEO OUT** jacks of the other equipment (DVD Player, Camcorder, etc.) and to the yellow **VIDEO** jack on the rear of the LCD TV Monitor.

2 If the other equipment has **red and white, left and right, stereo audio out jacks**: Connect **RCA-style audio cables (usually red and white)** to the **AUDIO OUT** (left and right) jacks on the other equipment. Connect the other end of the cables to the red and white **AUDIO** cable (provided). Connect the **AUDIO** cable provided to the **AUDIO 2** jack on the rear of the LCD TV Monitor. The LCD TV Monitor will receive sound from the other equipment in stereo (from the left and right sound channels).

If the other equipment has **only one AUDIO OUT (white) jack**: Connect an audio cable to the **AUDIO OUT** jack on the other equipment. Connect the other end of the cable to the **white AUDIO 2** jack on the rear of the LCD TV Monitor. The LCD TV Monitor will receive sound from the other equipment through a single audio channel.

3 Plug the **DC Adapter** into the **DC IN** jack on the TV. Plug the **power cable** into an outlet. Turn on the TV and other equipment.

4 Press the **Video Source** buttons to set the TV to its **VIDEO** channel.

5 Press **PLAY** on the other equipment to view its material on the TV.

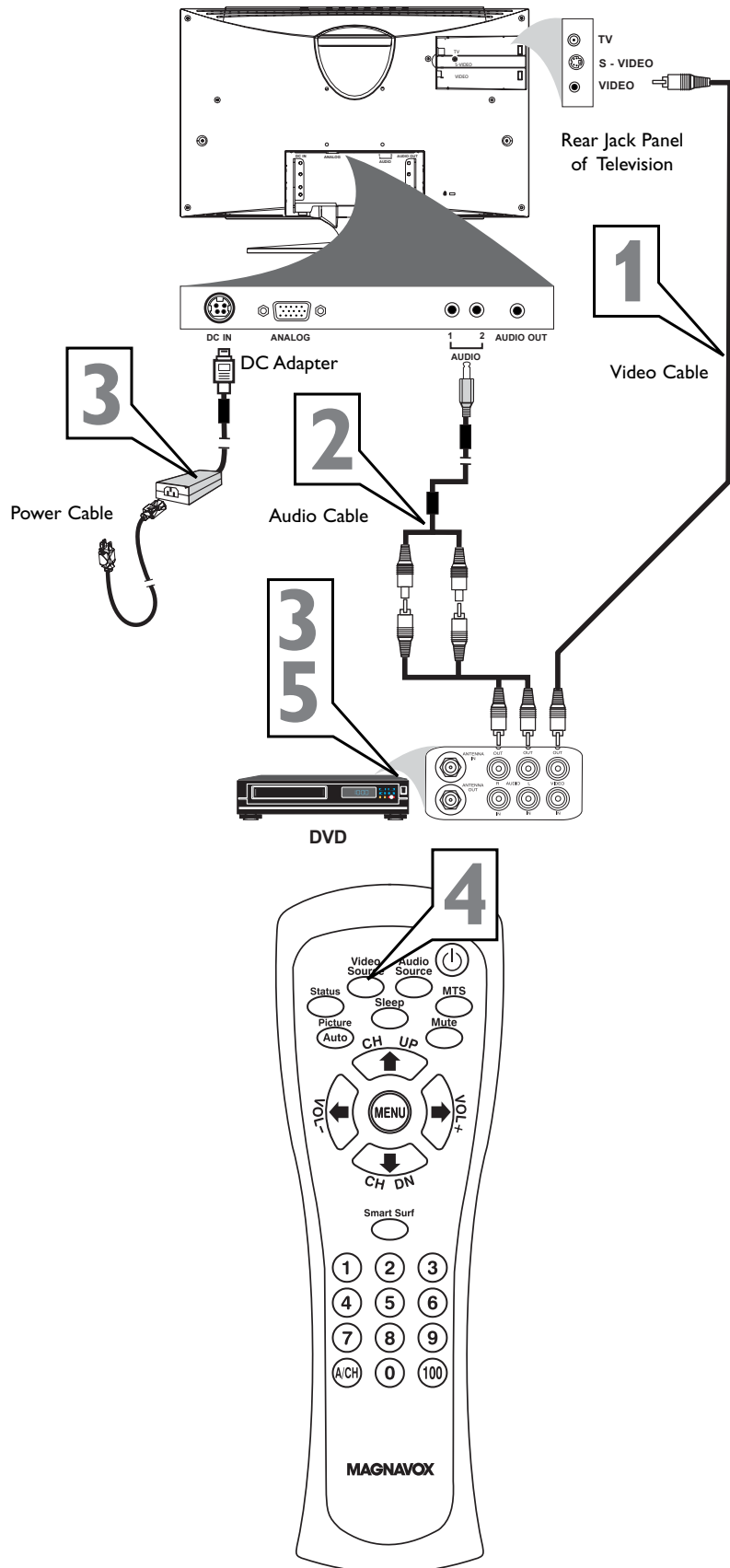



S-VIDEO CONNECTIONS

The *S*(uper)-Video connection on the rear of the LCD TV Monitor can provide you with better picture detail and clarity for the playback of accessory sources such as DBS (digital broadcast satellite), DVD (digital video discs), video games, and S-VHS VCR (video cassette recorder) tapes than the normal antenna picture connections.

NOTE: The accessory device must have an S-VIDEO OUT (put) jack in order for you to complete the connection on this page.

- 1** Connect an S-Video cable to the S-VIDEO jack of the other equipment (DVD Player, Camcorder, etc.) and to the S-VIDEO jack on the rear of the LCD TV Monitor.
- 2** If the other equipment has red and white, left and right, stereo audio out jacks: Connect RCA-style audio cables (usually red and white) to the AUDIO OUT (left and right) jacks on the other equipment. Connect the other end of the cables to the red and white AUDIO cable (provided). Connect the AUDIO cable provided to the AUDIO 2 jack on the rear of the LCD TV Monitor. The LCD TV Monitor will receive sound from the other equipment in stereo (from the left and right sound channels).

If the other equipment has only one AUDIO OUT (white) jack: Connect an audio cable to the AUDIO OUT jack on the other equipment. Connect the white end of the cable to the white end of the audio cable supplied. Connect the other end of that cable to the AUDIO 2 jack on the rear of the LCD TV Monitor. The LCD TV Monitor will receive sound from the other equipment through a single audio channel.

- 3** Plug the DC Adapter into the DC IN jack on the LCD TV Monitor. Plug the power cable into an outlet. Turn on the LCD TV Monitor and other equipment.
- 4** Press the Video Source buttons to set the LCD TV Monitor to its VIDEO channel, if the LCD Monitor does not automatically detect a source change.
- 5** Press PLAY on the other equipment to view its material on the LCD TV Monitor.

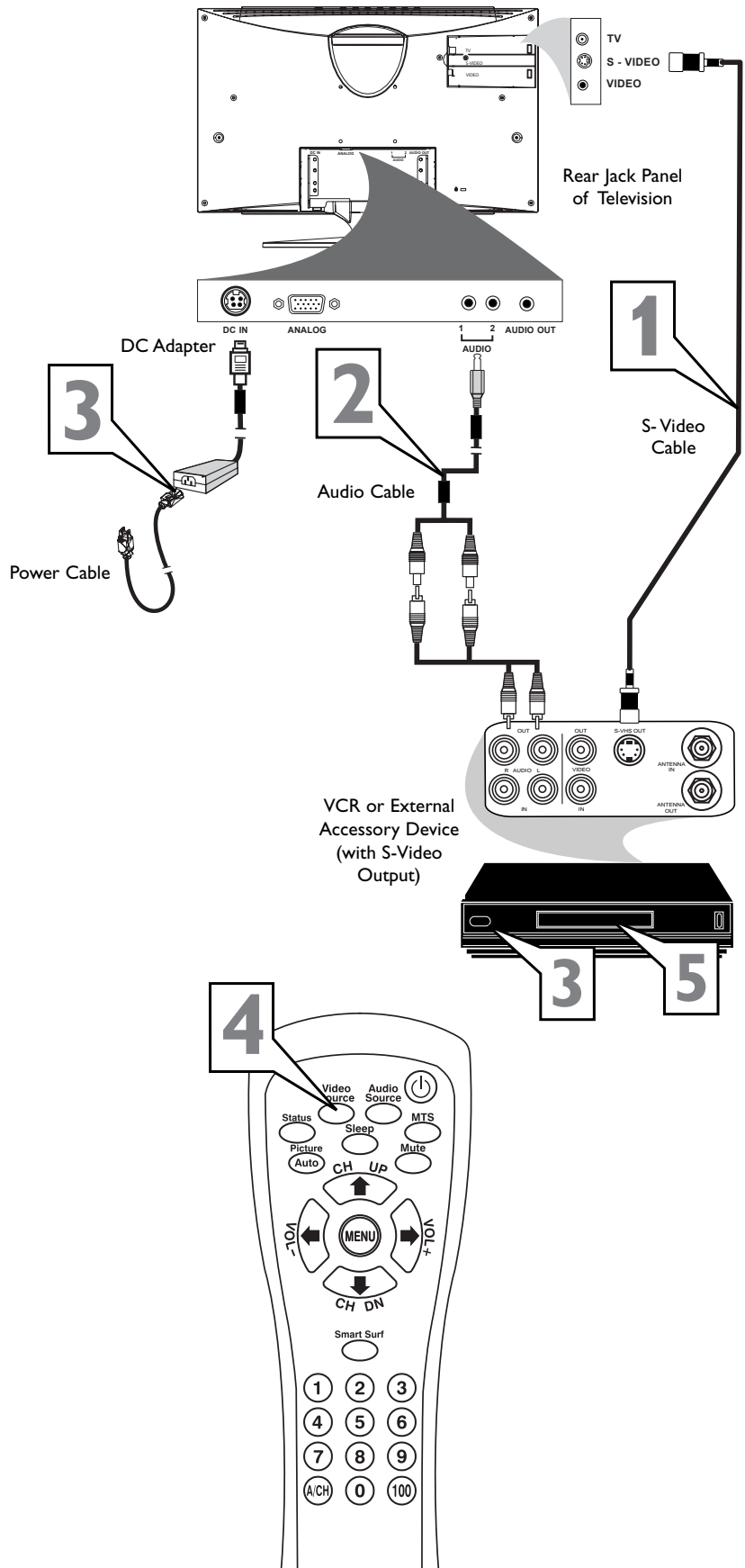

PC (MONITOR) CONNECTION



This LCD TV Monitor can be used as a PC Monitor. Your computer will have to be equipped with a VGA type video output and VGA cable.

- 1** Connect one end of the **VGA Video cable** to the Monitor (video) output on the computer to the **ANALOG** rear jack panel on the LCD TV Monitor.
- 2** Although audio connections are not required, the LCD TV Monitor can reproduce the computers audio out by an **AUDIO ADAPTER** (supplied) to the Audio output jack on the computer (if available) while connecting the other ends of the Audio cables to the **AUDIO 1** Input Jacks on the bottom of the TV. Press the Audio Source button until **AUDIO1:PC** appears so the TV tunes to the computer audio signal.
- 3** Turn the **LCD TV Monitor and the Computer ON.**
- 4** Press the **VIDEO SOURCE** button until **PC MODE** appears on the screen.

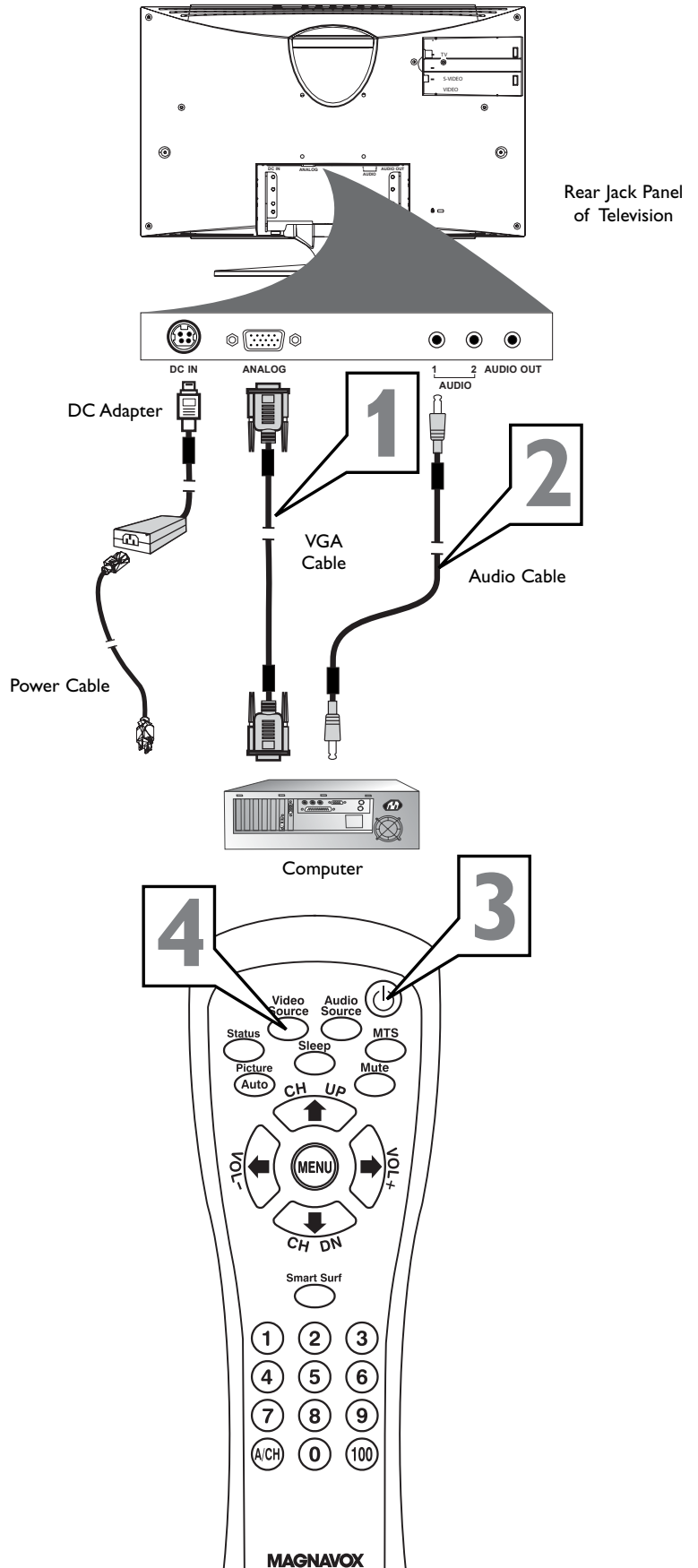



HOW TO USE THE TUNER MODE

The **TUNER MODE** allows you to change the LCD TV Monitor's signal input to **CABLE** or **AIR** (antenna). It's important for the LCD TV Monitor to know if you want to receive channels from a cable TV signal or an antenna signal.

- 1** Press the **MENU** button on the remote control to see the onscreen menu.
- 2** Press the **▲(CH UP)** or **▼(CH DN)** buttons to highlight the TV INSTALL menu.
- 3** Press the **▶(VOL+)** or **◀(VOL-)** buttons to enter the TV INSTALL menu.
- 4** Press the **▲(CH UP)** or **▼(CH DN)** buttons to highlight the TUNER MODE control.
- 5** Press the **▶(VOL+)** or **◀(VOL-)** buttons to select **CABLE** or **AIR** (antenna).
- 6** Press the **MENU** button repeatedly to clear the menu from the screen.

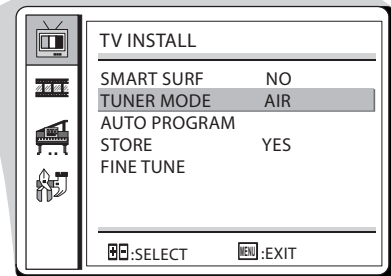
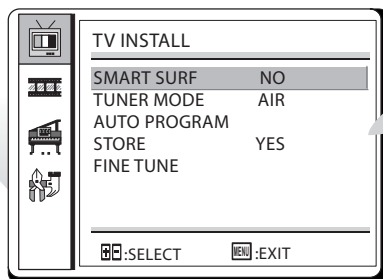

OR

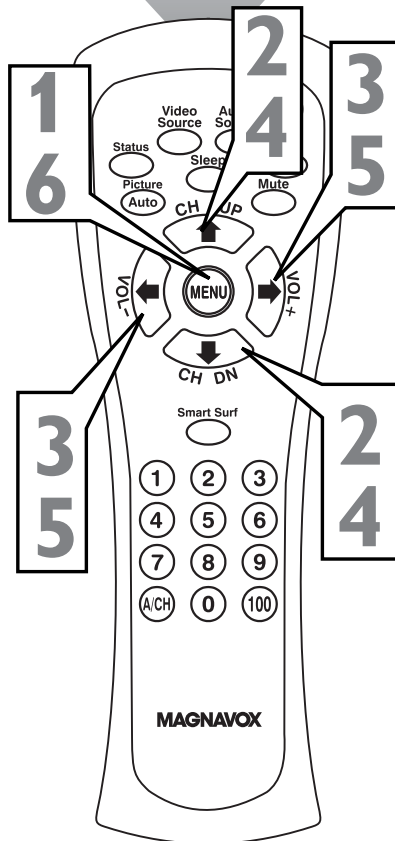
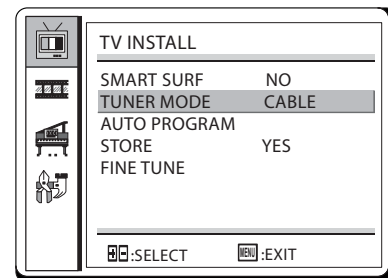

HELPFUL HINT

When **CABLE** is selected, channels 1-125 are available.

When **AIR** (antenna) is selected, channels are 2-69.

AUTO PROGRAM (SETTING UP CHANNELS)



Your LCD TV Monitor can automatically set itself for local area (or cable TV) channels. This makes it easy for you to select only the TV stations in your area by pressing the CH UP or CH DN button.

- 1** Press the **MENU** button on the remote control to show the onscreen menu.
- 2** Press the **▲(CH UP)** or **▼(CH DN)** buttons to highlight the TV INSTALL menu.
- 3** Press the **▶(VOL-)** or **◀(VOL+)** buttons to enter the TV INSTALL menu.
- 4** Press the **▲(CH UP)** or **▼(CH DN)** buttons to highlight the AUTO PROGRAM control.
- 5** Press the **▶(VOL+)** or **◀(VOL-)** button to start the Auto Program scanning of channels.
- 6** Press the **MENU** button repeatedly to clear the menu from the screen.

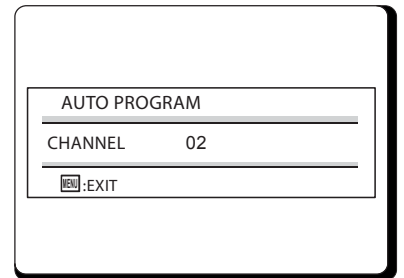
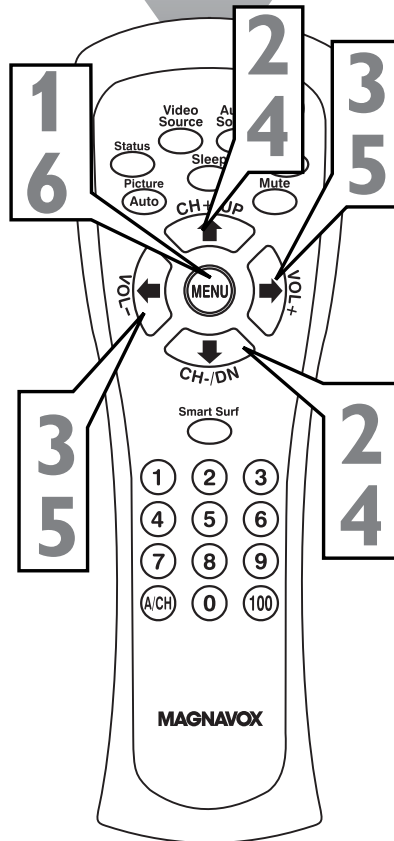
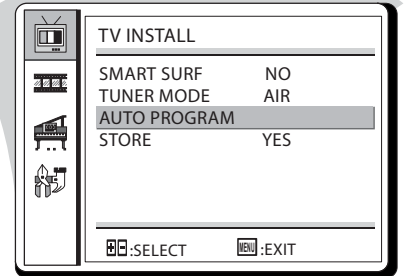
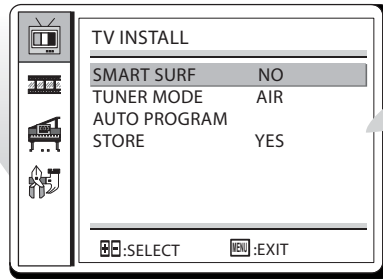

HELPFUL HINT

After you've run Auto Program, check out the results. Press the CH+/UP or the CH-DN button and see which channels you can select.

Remember, an antenna or cable TV signal must first be connected to your LCD TV Monitor (see pages 7-10 of this owner's manual).



STORE

Store lets you edit the channel listing. You can add or remove a channel in the LCD TV Monitor's memory.

- 1** Press the number buttons or the **▲(CH UP)** or **▼(CH DN)** buttons to tune to a specific channel that you want to add or remove from the LCD TV Monitor's memory.
- 2** Press the **MENU** button to show the onscreen menu.
- 3** Press the **▲(CH UP)** or **▼(CH DN)** buttons to highlight the TV INSTALL menu.
- 4** Press the **▶(VOL+)** or **◀(VOL-)** buttons to enter the TV Install Menu.
- 5** Press the **▲(CH UP)** or **▼(CH DN)** buttons to select STORE.
- 6** Press the **▶(VOL+)** or **◀(VOL-)** button to highlight YES to add the channel or NO to delete it from the LCD TV Monitor's memory.
- 7** Press the **MENU** button repeatedly to clear the menu from the screen.

Repeat steps 1-7 to add or delete additional channels to or from the LCD TV Monitor's memory.

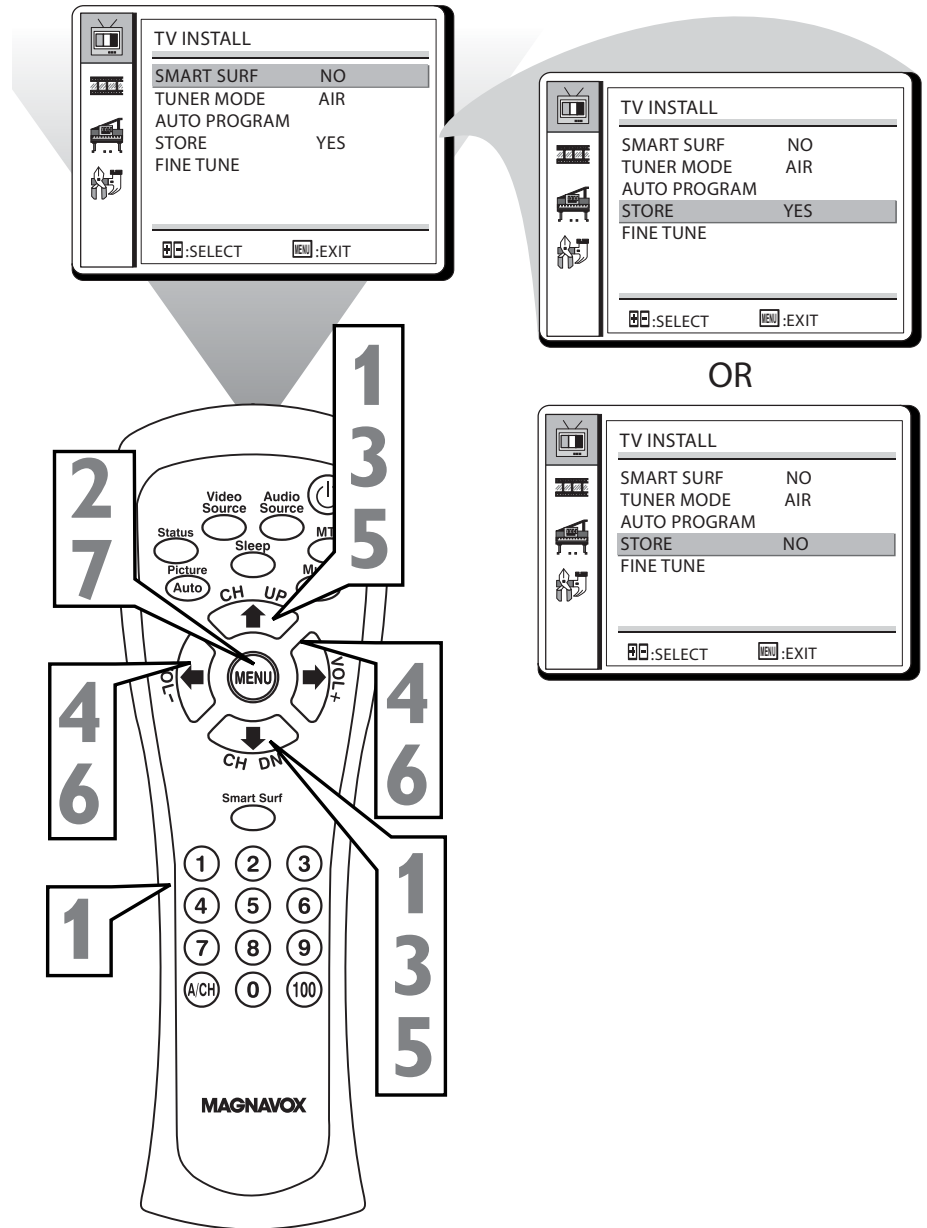



Smart Surf lets you set up channels in a quick viewing list. Then, you can use the Smart Surf button on the remote control to switch between different TV programs (channels) that interest you.

- 1** Press the number buttons or the **▲(CH UP)** or **▼(CH DN)** buttons to tune to a specific channel that you want to add to the Smart Surf feature.
- 2** Press the **MENU** button to show the onscreen menu.
- 3** Press the **▲(CH UP)** or **▼(CH DN)** buttons highlight the TV INSTALL menu.
- 4** Press the **▶(VOL+)** or **◀(VOL-)** buttons to enter the TV Install Menu.
- 5** Press the **▲(CH UP)** or **▼(CH DN)** buttons to select SMART SURF.
- 6** Press the **▶(VOL+)** or **◀(VOL-)** buttons to highlight YES to add the channel to your Smart Surf list or NO to remove the channel from the list.
- 7** Press the **MENU** button repeatedly to clear the menu from the screen.

Repeat steps 1-7 to add or remove additional channels to or from the Surf list.

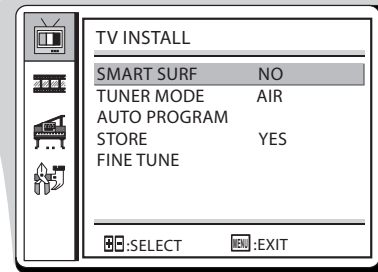
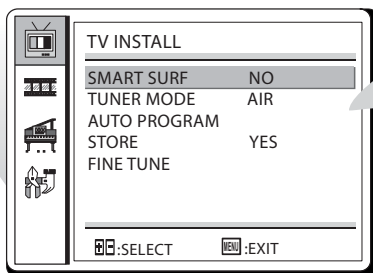

OR

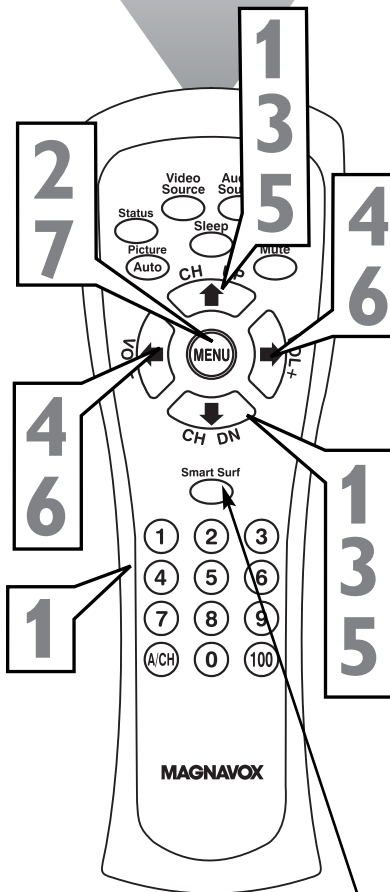
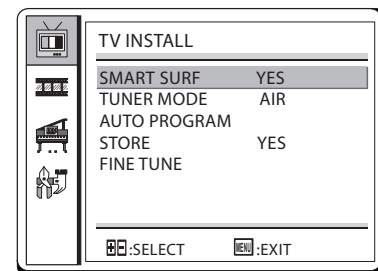

Press SMART SURF repeatedly during TV viewing to scan through the channels in the SURF list.

A/CH BUTTON

Your remote control has an A/CH (Alternate Channel) button. Press A/CH to toggle between the current and previous channel.

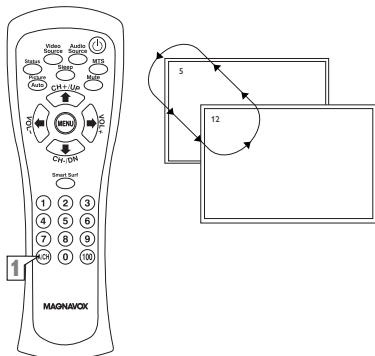



FINE TUNE

*F*ine Tune allows you to adjust the LCD TV Monitor's picture reception in areas of weak signal reception.

- 1** Press the **MENU** button on the remote control to see the onscreen menu.
- 2** Press the **▲(CH UP)** or **▼(CH DN)** buttons to highlight the TV INSTALL menu.
- 3** Press the **▶(VOL+)** or **◀(VOL-)** buttons to enter the TV INSTALL menu.
- 4** Press the **▲(CH UP)** or **▼(CH DN)** buttons to highlight FINE TUNE.
- 5** Press the **▶(VOL+)** or **◀(VOL-)** buttons to adjust the fine tune setting.
- 6** Press the **MENU** button repeatedly to clear the menu from the screen.

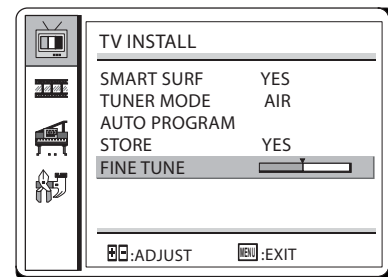
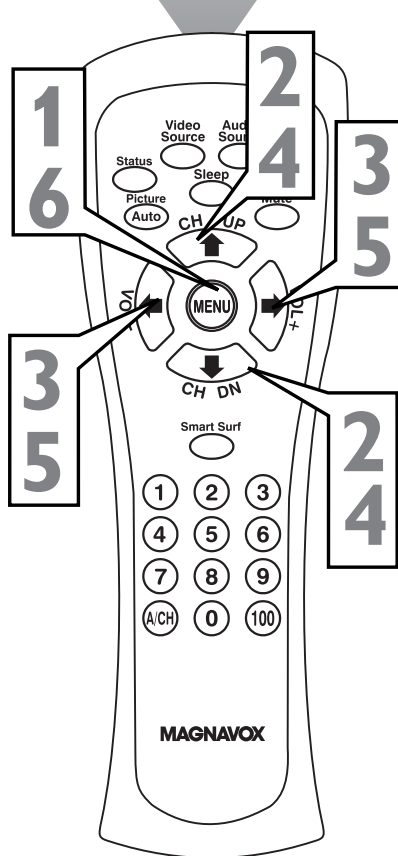
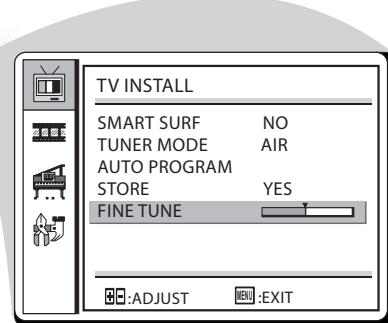
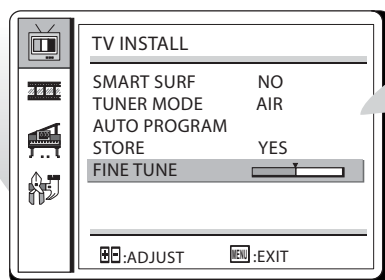

TV PICTURE MENU CONTROLS



To adjust your LCD Monitor picture, select a channel and follow these steps.

- 1** Press the **MENU** button to see the onscreen menu.
- 2** Press the **▲(CH UP)** or **▼(CH DN)** buttons to highlight the **PICTURE** menu.
- 3** Press the **▶(VOL+)** or **◀(VOL-)** buttons to enter the **PICTURE** menu.
- 4** Press the **▲(CH UP)** or **▼(CH DN)** buttons to choose the item you want to adjust: Brightness, Color, Contrast, Tint, Sharpness, Backlight, or Gamma.
- 5** Press the **▶(VOL+)** or **◀(VOL-)** buttons to adjust the item.
- 6** Press the **▲(CH UP)** or **▼(CH DN)** buttons to select and adjust other picture controls.
- 7** Press the **MENU** button repeatedly to remove the menu.

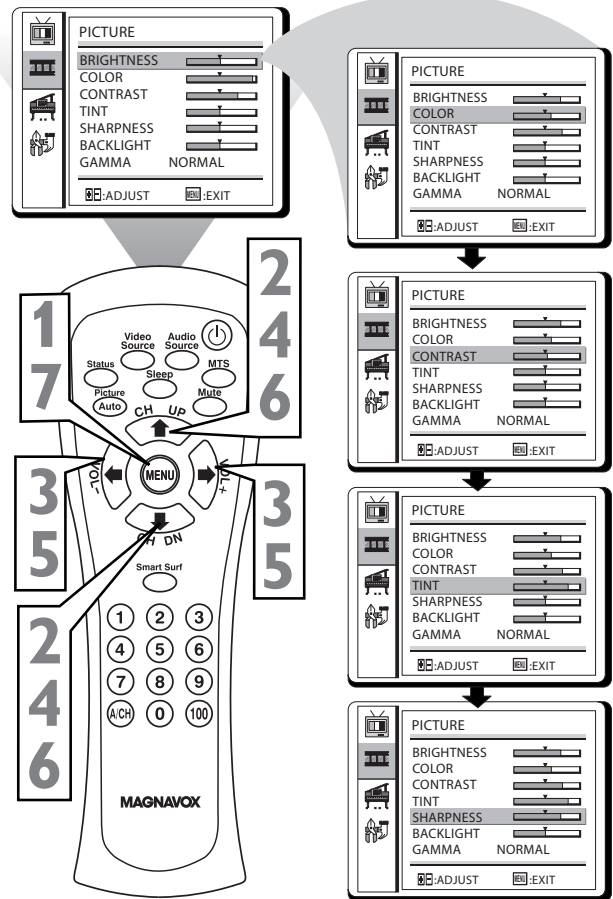

Note: Some items on the picture menu can be accessed by pressing **AUTO** on the remote control.

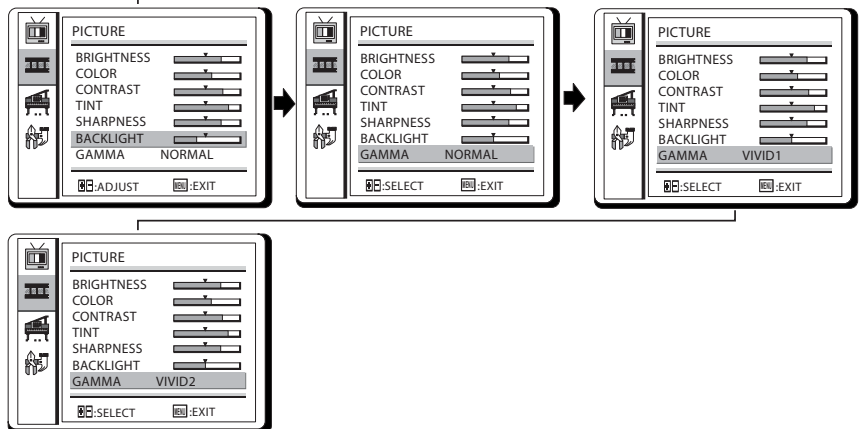

HELPFUL HINTS

Brightness: Adjust to brighten the dark parts of the picture. This appears to add white to the color.

Color: Adjust to add or reduce color.

Contrast: Adjust to “sharpen” the Picture quality. The black portions of the picture become richer in darkness and the white become brighter.

Tint: Adjust to obtain natural skin tones.

Sharpness: Adjust to improve detail.

Backlight: Adjust the brightness of the picture while preserving the picture’s color.

Gamma: Preset contrast scheme to enhance picture quality. Choose from **NORMAL**, **VIVID1**, or **VIVID2**.



TV SOUND MENU CONTROLS

To adjust your LCD TV Monitor Sound, select a channel and follow these steps.

- 1** Press the **MENU** button to see the menu.
- 2** Press the **▲(CH UP)** or **▼(CH DN)** buttons to highlight the **SOUND** menu.
- 3** Press the **▶(VOL+)** or **◀(VOL-)** buttons to enter the **SOUND** menu.
- 4** Press the **▲(CH UP)** or **▼(CH DN)** buttons to choose the item you want to adjust: Treble, Bass, Balance, or Sound Mode.
- 5** Press the **▶(VOL+)** or **◀(VOL-)** buttons to adjust the item.
- 6** Press the **▲(CH UP)** or **▼(CH DN)** buttons to select and adjust other sound controls.
- 7** Press **MENU** to remove the menu.

Note: You can change the sound from Mono to Stereo or SAP (if supported by the program) by pressing the MTS button.

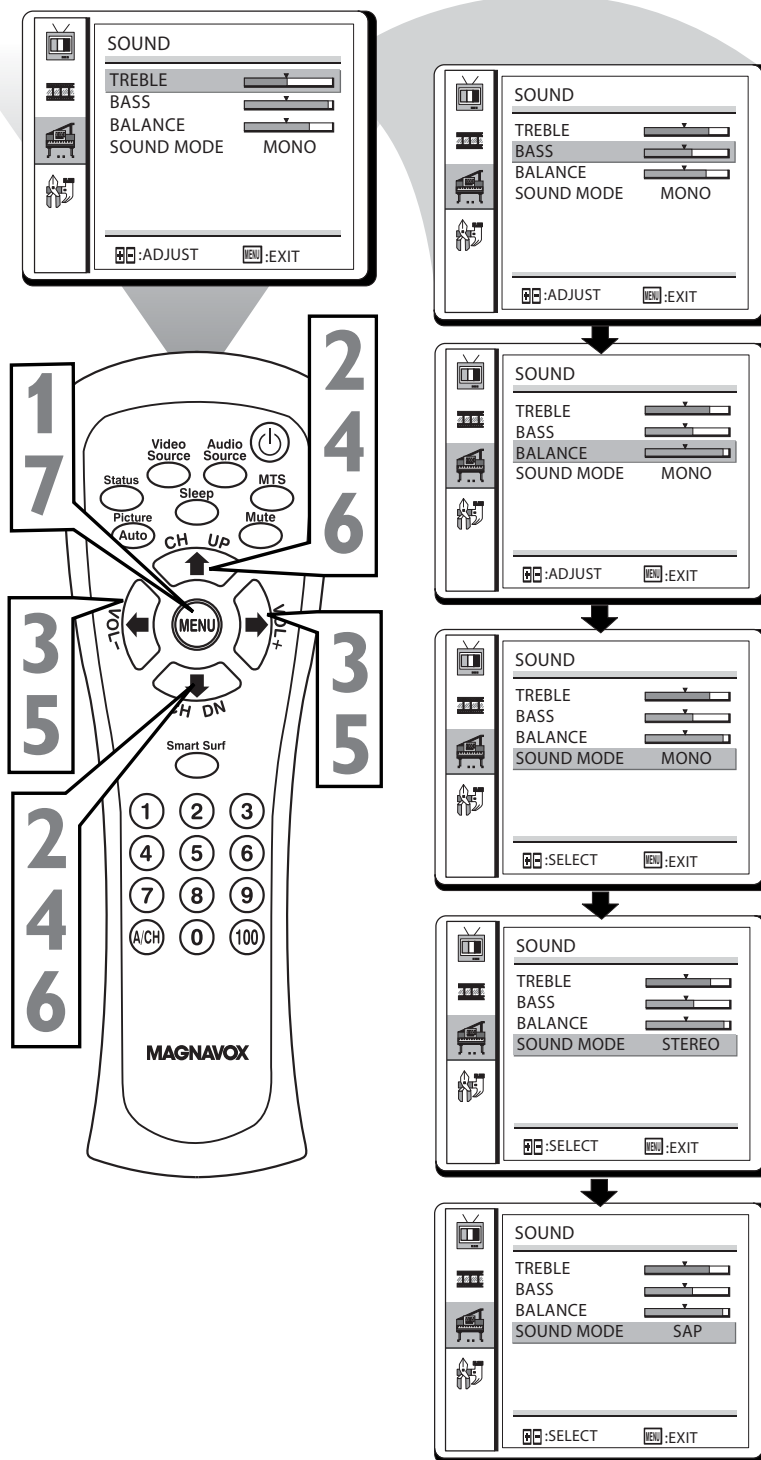

HELPFUL HINTS

Treble: Adjust to enhance the high frequency sounds.

Bass: Adjust to enhance the low frequency sounds.

Balance: Adjusts the level of sounds coming from the left and right speakers.

Sound Mode: Adjust to select between Stereo, Mono, or SAP. NOTE: If stereo is not present on a selected show and the TV is placed in Stereo mode, the sound coming from the TV will remain in Mono mode.



The Smart Lock feature is an integrated circuit that receives and processes data sent by broadcasters, or other program providers, that contain program content advisories. When programmed by the viewer, a TV with Smart Lock can respond to the content advisories and block program content that may be found objectionable (such as offensive language, violence, sexual situations, etc.). This is a great feature to censor the type of viewing children may watch.

Smart Lock offers various BLOCKING controls from which to choose:

Access Code - An Access Code must be set to prevent children from unblocking questionable or censored programming set by their parents.

Block Enable - After an access code has been programmed, you can block programming depending on the received rating and user setting.

Movie Ratings - Certain blocking options exist which will block programming based on ratings patterned by the Motion Pictures Association of America.

TV Ratings - Just like the Movie Ratings, programs can be blocked from viewing using standard TV ratings set by TV broadcasters.

MOVIE RATING	
G	U
PG	U
PG-13	U
R	U
NC-17	U
X	U

SELECT: EXIT:

TV RATING	
TVY	U
TVY7	U FV U
TVG	U
TVPG	U VUSULUDU
TV14	U VUSULUDU
TVMA	U VUSULU

SELECT: EXIT:

MOVIE RATINGS

G: General Audience - All ages admitted. Most parents would find this program suitable for all ages. This type of programming contains little or no violence, no strong language, and little or no sexual dialog or situations.

PG: Parental Guidance Suggested - This programming contains material that parents may find unsuitable for younger children. It may contain one or more of the following: moderate violence, some sexual situations, infrequent coarse language, or some suggestive dialog.

PG-13: Parents Strongly Cautioned - This programming contains material that parents may find unsuitable for children under the age of 13. It contains one or more of the following: violence, sexual situations, coarse language, or suggestive dialog.

R: Restricted - This programming is specifically designed for adults. Anyone under the age of 17 should only view this programming with an accompanying parent or adult guardian. It contains one or more of the following: intense violence, intense sexual situations, strong coarse language, or intensely suggestive dialog.

NC-17: No children under the age of 17 will be admitted. - This type of programming should be viewed by adults only. It contains graphic violence, explicit sex, or crude, indecent language.

X: Adults Only - This type of programming contains one or more of the following: very graphic violence, very graphic and explicit or indecent sexual acts, and very coarse and intensely suggestive language.

TV RATINGS

TV-Y All children - Appropriate for all children. Designed for a very young audience, including children ages 2-6. This type of programming is not expected to frighten younger children.

TV-Y7 Directed to Older Children - Designed for children age 7 and above. It may be more appropriate for children who can distinguish between make-believe and reality. This programming may include mild fantasy and comic violence (FV or fantasy violence).

TV-G General Audience - Most parents would find this programming suitable for all ages. This type of programming contains little or no violence, no strong language, and little or no sexual dialog or situations.

TV-PG Parental Guidance Suggested - Contains material that parents may find unsuitable for younger children. This type of programming contains one or more of the following: Moderate violence (V), some sexual situations (S), infrequent coarse language (L), or some suggestive dialog (D).

TV-14 Parents Strongly Cautioned - Contains some material that many parents would find unsuitable for children under age 14. This type of programming contains one or more of the following: intense violence (V), intense sexual situations (S), strong coarse language (L), or intensely suggestive dialog (D).

TV-MA Mature Audience Only - Specifically designed to be viewed by adults and may be unsuitable for children under 17. This type of programming contains one or more of the following: graphic violence (V), explicit sexual situations (S), or crude, indecent language (L).



SMART LOCK ACCESS CODE

Over the next few pages you'll learn how to block programs and understand the rating terms for certain broadcasts. First, set an access code.

- 1** Press the **MENU** button to see the onscreen menu.
- 2** Press the **▲(CH UP)** or **▼(CH DN)** buttons to highlight the **FEATURES** menu.
- 3** Press the **▶(VOL+)** or **◀(VOL-)** buttons to enter the **FEATURES** menu.
- 4** Press the **▲(CH UP)** or **▼(CH DN)** buttons to select **SMART LOCK**.
- 5** Press the **▶(VOL+)** or **◀(VOL-)** buttons. **INPUT USER CODE** will appear on the screen.
- 6** Use the **Number** buttons to enter **9, 2, 0, 3**. This is the LCD TV MONITOR's default code. "----" will appear on the screen as you enter the code. This protects its identity. If **INCORRECT** appears, repeat steps 5 and 6.
- 7** The **SMART LOCK** menu will appear. Check to see if **CHANGE USER CODE** is highlighted, press the **▶(VOL+)** or **◀(VOL-)** buttons.
- 8** The screen will prompt you to enter a new code. **Enter a new four-digit code using the Number** buttons. The screen will prompt you to **confirm the code you just entered**. **Enter your same new code again**. "----" will appear when you enter your new code, then the **Smart Lock** menu will appear.
- 9** Press **MENU** repeatedly to remove the menu from the screen.

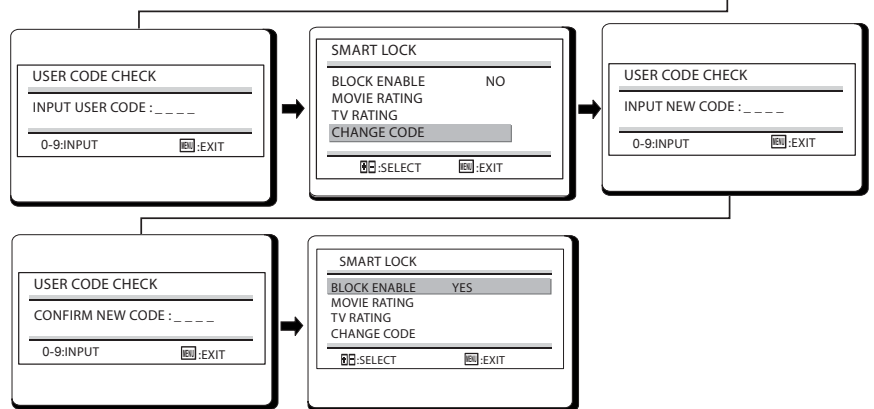
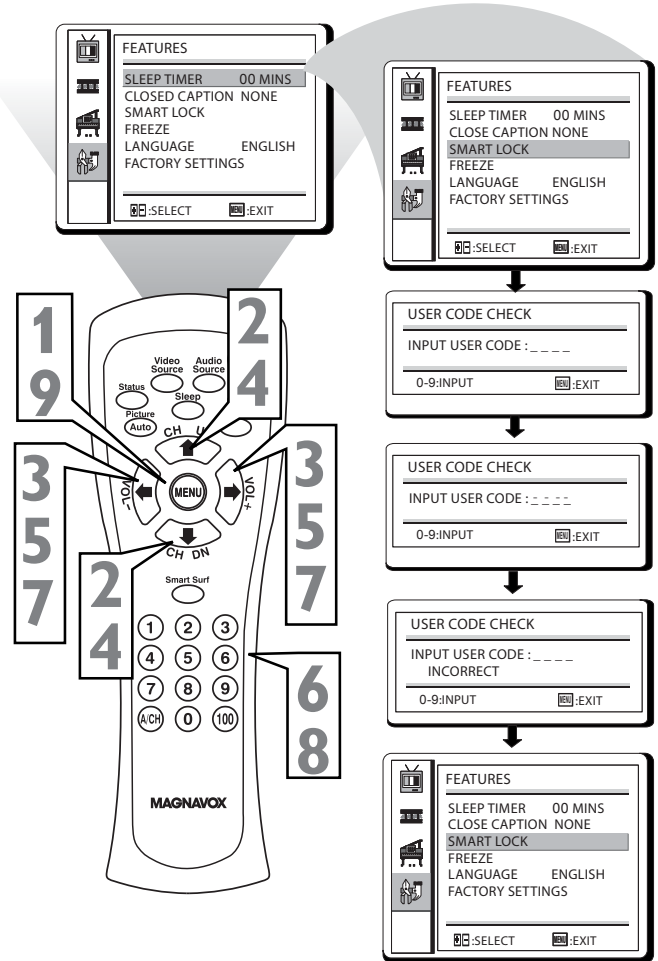

To change the Access Code later, follow steps 1-6 so the Smart Lock menu appears.

HELPFUL HINTS

You cannot unblock a channel without knowing your code or changing it. If your code changes, someone has altered it and possibly viewed blocked channels.

If you forget your access code, you must reset the Factory Settings, details on page 27.

SMART LOCK- BLOCK ENABLE



After your personal access code has been set (see the previous page), you are ready to select the channels or inputs you want to block out or censor.

- 1** Press the **MENU** button to see the onscreen menu.
- 2** Press the **▲(CH UP)** or **▼(CH DN)** buttons to highlight the **FEATURES** menu.
- 3** Press the **▶(VOL+)** or **◀(VOL-)** buttons to enter the **FEATURES** menu.
- 4** Press the **▲(CH UP)** or **▼(CH DN)** buttons to select **SMART LOCK**.
- 5** Press the **▶(VOL+)** or **◀(VOL-)** buttons **INPUT USER CODE** will appear.
- 6** Use the **Number** buttons to enter your access code.
- 7** Press the **▲(CH UP)** or **▼(CH DN)** buttons to select **BLOCK ENABLE**.
- 8** Press the **▶(VOL+)** button to block a certain channel or **◀(VOL-)** button to unblock a channel.
- 9** Press **MENU** repeatedly to remove the menu from the screen.

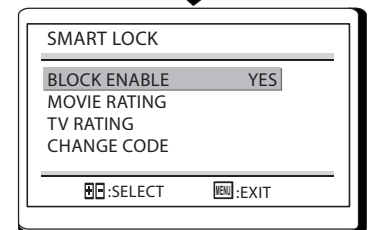
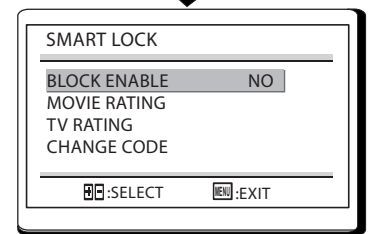
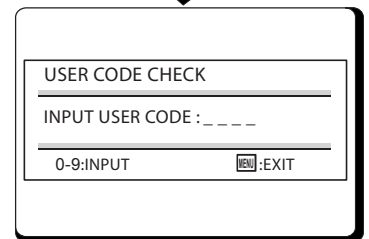
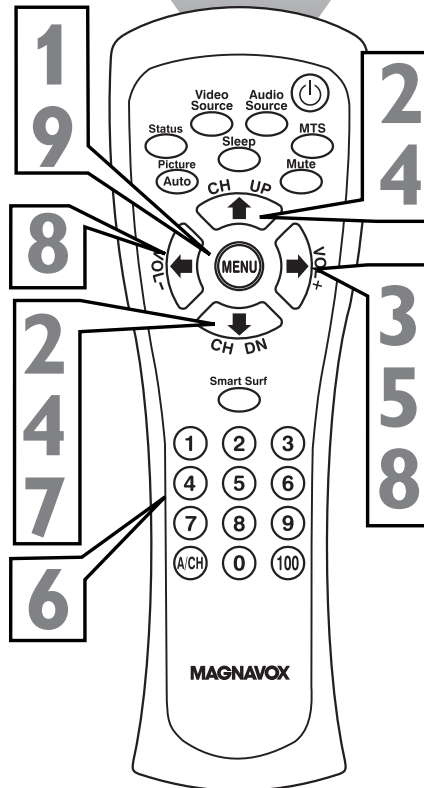
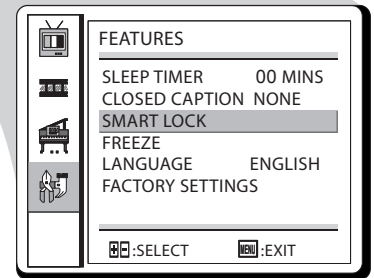
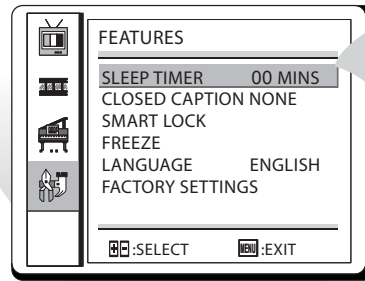

NOTE: Repeat the steps above to block additional channels.

HELPFUL HINT

If you enter your Access Code to view a blocked channel, ALL blocked channels will be viewable until you turn off the TV. Channels will be blocked as before when you turn on the TV again.

When you set one of the ratings (Movie or TV) to ON, Block Enable will automatically turned on. If you change the setting to OFF or when no rating is set, Block Enable will be turned off.



SMART LOCK - MOVIE RATINGS

The Smart Lock feature can block programming based on the Movie Industry ratings.

Once you've entered your access code and the Smart Lock features are displayed on the screen:

- 1 Press the **MENU** button to see the onscreen menu.
- 2 Press the **▲(CH UP)** or **▼(CH DN)** buttons to highlight the **FEATURES** menu.
- 3 Press the **▶(VOL+)** or **◀(VOL-)** buttons to enter the **FEATURES** menu.
- 4 Press the **▲(CH UP)** or **▼(CH DN)** buttons to select **SMART LOCK**.
- 5 Press the **▶(VOL+)** or **◀(VOL-)** buttons **INPUT USER CODE** will appear.
- 6 Use the **Number** buttons to enter your access code.
- 7 Press the **▲(CH UP)** or **▼(CH DN)** buttons to select **MOVIE RATING**.
- 8 Press the **▶(VOL+)** or **◀(VOL-)** buttons to highlight any of the Movie Rating options. When highlighted, all these options can be (B) blocked or (U) unblocked.
- 9 Press **MENU** repeatedly to remove the menu from the screen.

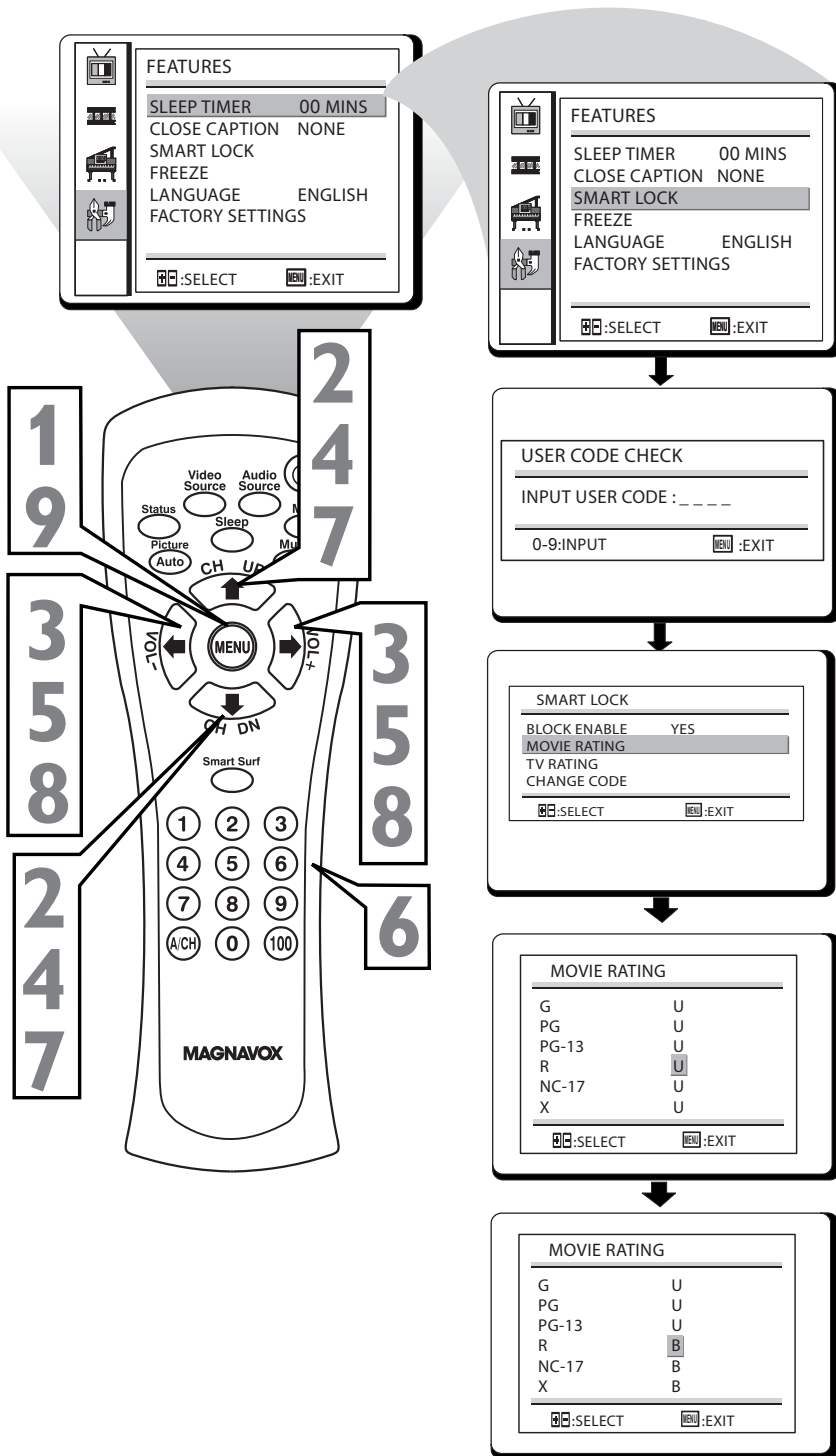

NOTE: When a rating is chosen to be blocked, any higher level rating will also be blocked from viewing. (i.e.: If "R" is selected to be blocked, NC-17 and X will automatically be blocked.) Also, when a rating is set to unblock, any rating lower will be automatically set to unblock. (i.e: if PG-13 is blocked, PG and G will automatically be unblocked.)

SMART LOCK - TV RATINGS



The Smart Lock feature can block programming based on the TV Industry ratings. Once you've entered your access code and the Smart Lock features are displayed on the screen:

- 1 Press the **MENU** button to see the onscreen menu.
- 2 Press the **▲(CH UP)** or **▼(CH DN)** buttons to highlight the **FEATURES** menu.
- 3 Press the **▶(VOL+)** or **◀(VOL-)** buttons to enter the **FEATURES** menu.
- 4 Press the **▲(CH UP)** or **▼(CH DN)** buttons to highlight **Smart Lock**.
- 5 Press the **▶(VOL+)** or **◀(VOL-)** buttons, **INPUT USER CODE** will appear on the screen.
- 6 Use the **Number** buttons to enter your access code.
- 7 Press the **▲(CH UP)** or **▼(CH DN)** buttons to select **TV RATING**.
- 8 Press the **▶(VOL+)** or **◀(VOL-)** buttons to highlight any of the TV Rating options. When highlighted, all these options can be (B) blocked or (U) unblocked.
- 9 Press **MENU** repeatedly to remove the menu from the screen.

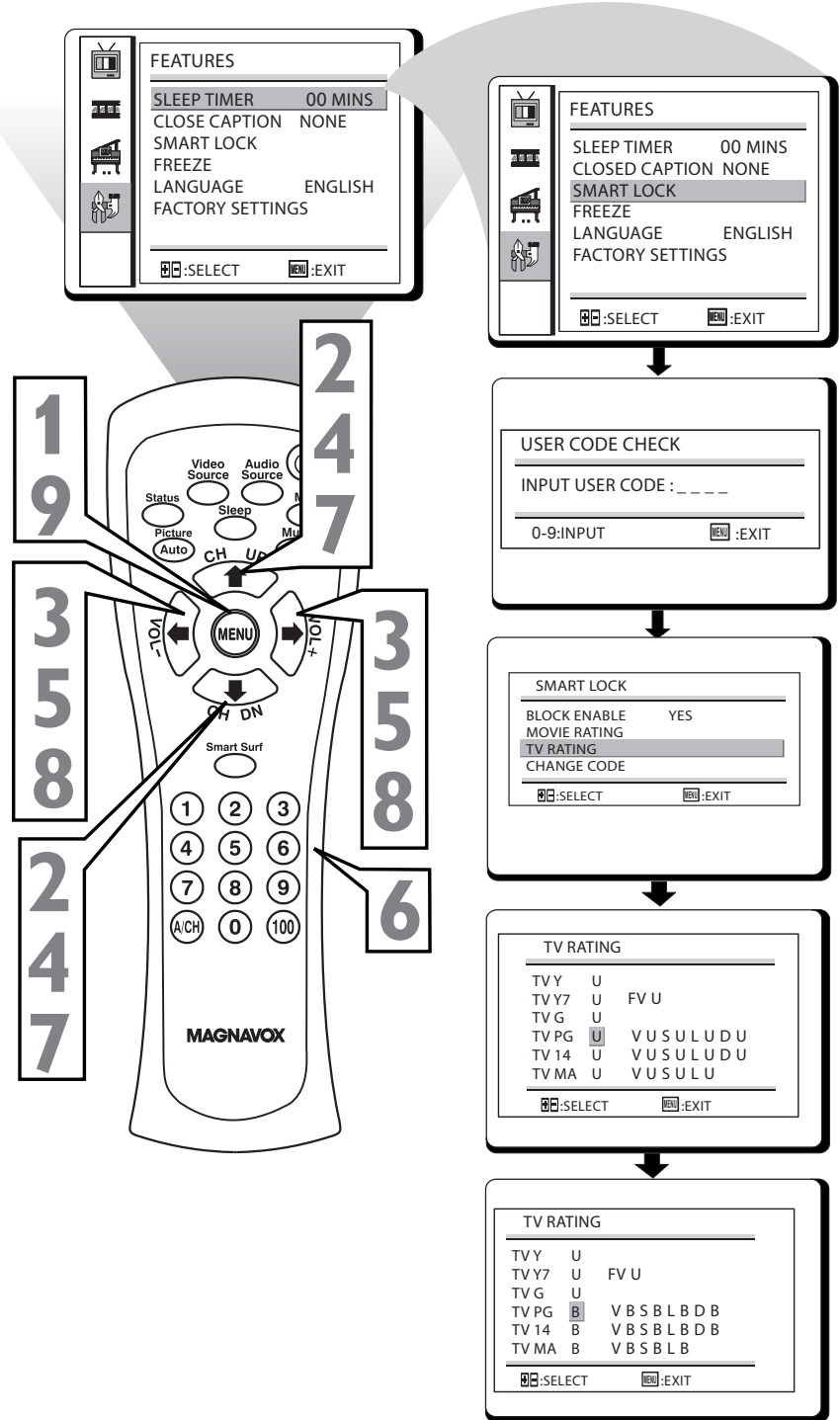



SLEEP TIMER

Your TV can be set to automatically turn itself off at a given amount of time.

1 Press the SLEEP button on the remote control and the SLEEP timer display will appear on the screen.

2 Press the SLEEP button repeatedly to pick the amount of time (30, 60, 90, or 120 minutes) before the TV will turn itself off.

NOTE: An onscreen count down will appear during the last minute before the TV shuts itself off. If any button is pressed during the last minute of the countdown, the Sleep timer setting will be cancelled.

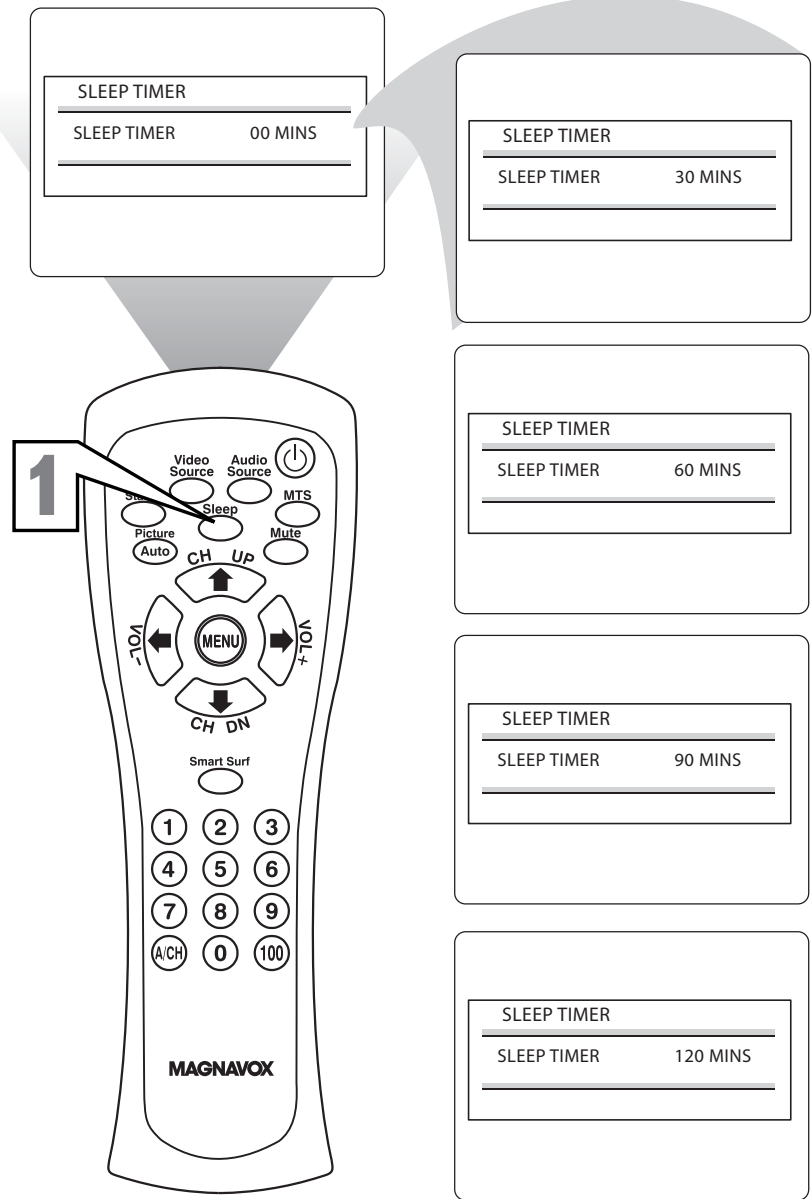

HELPFUL HINT

To see how many minutes remain before the TV shuts itself off, press the MENU button.

A Sleep Timer setting can be cancelled by pressing any button during the last minute of the operation.

CLOSED CAPTIONS



Closed Captioning (CC) allows you to read the voice content of television programs on the TV screen. Designed to help the hearing impaired, this feature uses onscreen "text boxes" to show dialogue and conversations while the TV program is in progress.

- 1** Press the **MENU** buttons to see the onscreen menu.
- 2** Press the **▲(CH UP)** or **▼(CH DN)** buttons to highlight the **FEATURES** menu.
- 3** Press the **▶(VOL+)** or **◀(VOL-)** buttons to enter the **FEATURES** menu.
- 4** Press the **▲(CH UP)** or **▼(CH DN)** buttons to select **CLOSE CAPTION**.
- 5** Press the **▶(VOL+)** or **◀(VOL-)** buttons to select the closed caption you want: **NONE**, **CC1**, **CC2**, **Txt1**, or **Txt2**.
- 6** Press **MENU** repeatedly to remove the menu from the screen.

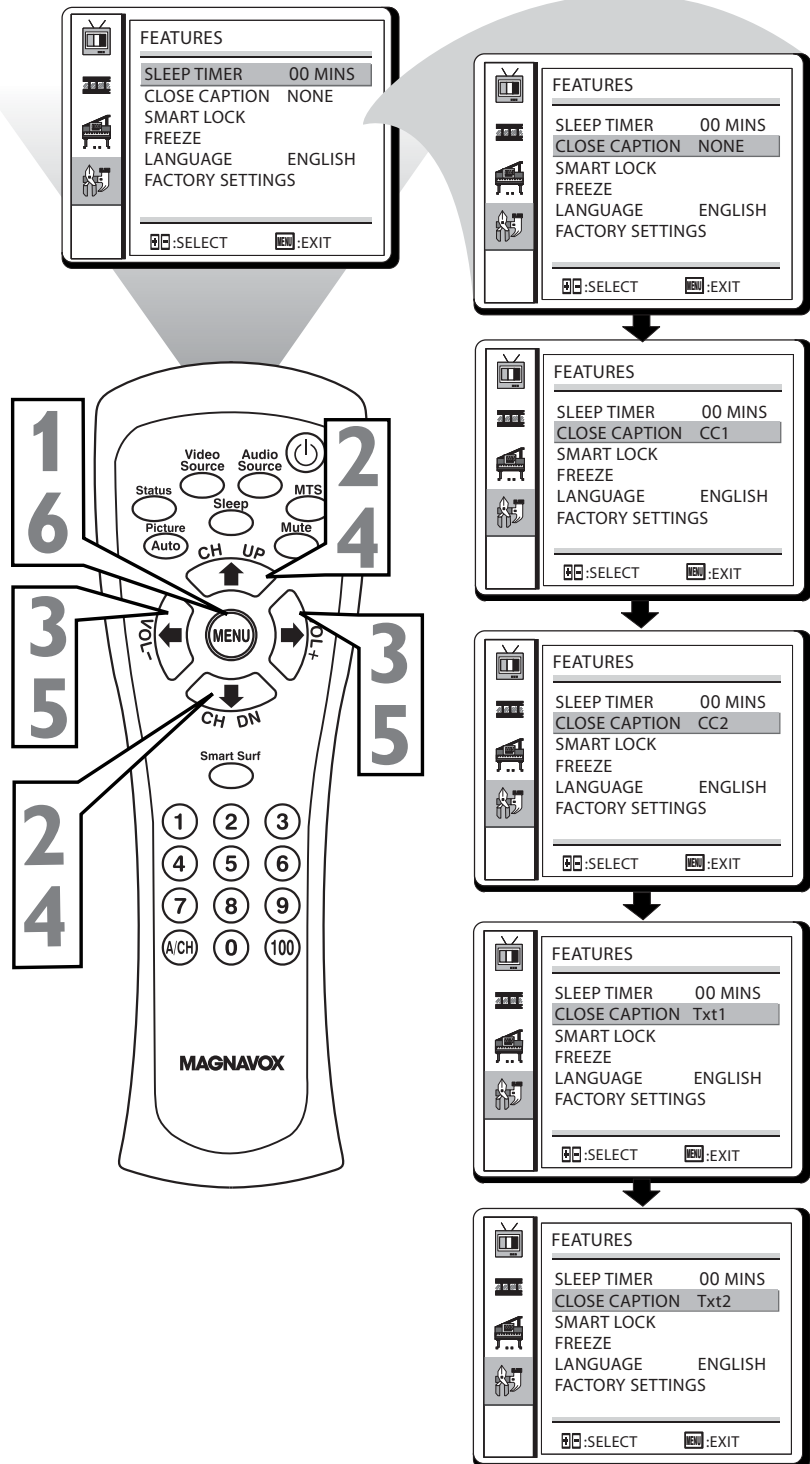

HELPFUL HINT

Not all TV programs and product commercials are broadcast with Closed Captioning (CC). Nor are all Closed Captioning MODES (CAPTION 1–2 or TEXT 1–2) necessarily being used by broadcast stations during the transmission of a program offering Closed Captioning. Refer to your area's TV program listings for the stations and times of shows being broadcast with Closed Captioning.



FREEZE

Have you ever wished you could freeze the picture on the television broadcast to write down telephone number or an address? Your new LCD TV Monitor will allow you to do just that.

- 1** Press the **MENU** button on the remote control to see the onscreen menu.
- 2** Press the **▲(CH UP)** or **▼(CH DN)** buttons to highlight the **FEATURES** menu.
- 3** Press the **▶(VOL+)** or **◀(VOL-)** buttons to enter the **FEATURES** menu.
- 4** Press the **▲(CH UP)** or **▼(CH DN)** buttons to highlight **FREEZE**.
- 5** Press the **▶(VOL+)** or **◀(VOL-)** buttons to turn **FREEZE ON** or **OFF**.
- 6** Press the **MENU** button repeatedly to clear the menu from the screen.

NOTE: If the picture has been frozen, follow these steps again to turn it OFF.

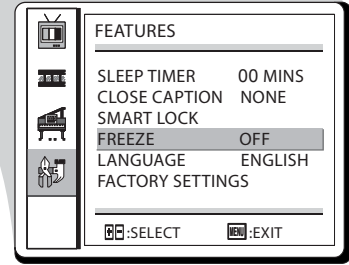
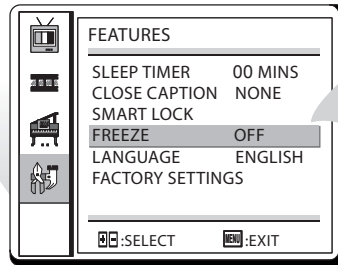

OR

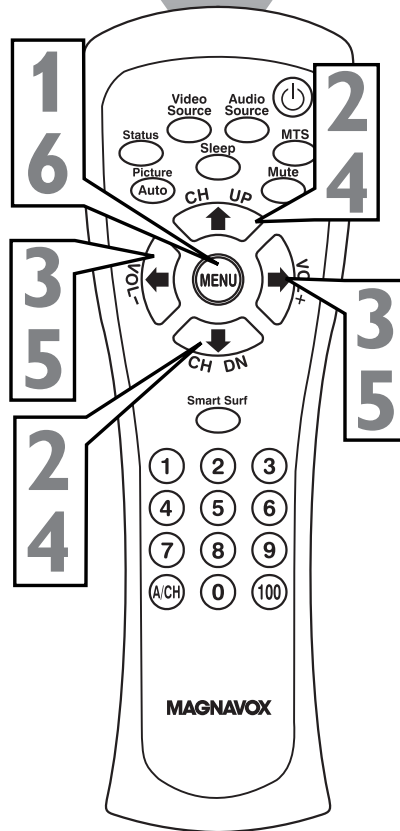
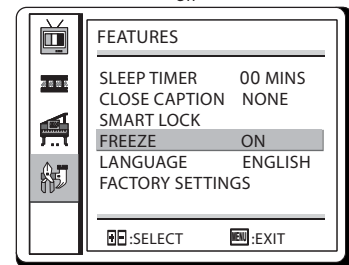

HELPFUL HINT

After freezing a picture on the screen, when the FREEZE control is turned OFF, the normal signal programming will be shown at present time. The signal that was being shown while the picture was frozen will not be viewable.

For the FREEZE feature to be most useful, always return to the TV INSTALL menu, highlight FREEZE, then exit the menu. If you have done this, when you see a telephone number or an address that you want to write down, just press the MENU and the VOL+ or VOL- twice to turn FREEZE ON.



For English or Spanish-speaking TV owners, an onscreen LANGUAGE option is present. The LANGUAGE control enables you to set the TV's onscreen menu to be shown in either English or Spanish.

- 1** Press the **MENU** button on the remote control to see the onscreen menu.
- 2** Press the **▲(CH UP)** or **▼(CH DN)** buttons to highlight the FEATURES menu.
- 3** Press the **▶(VOL+)** or **◀(VOL-)** buttons to enter the FEATURES menu.
- 4** Press the **▲(CH UP)** or **▼(CH DN)** buttons to highlight LANGUAGE.
- 5** Press the **▶(VOL+)** or **◀(VOL-)** buttons to select English or Spanish.
- 6** Press the **MENU** button repeatedly to clear the menu from the screen.

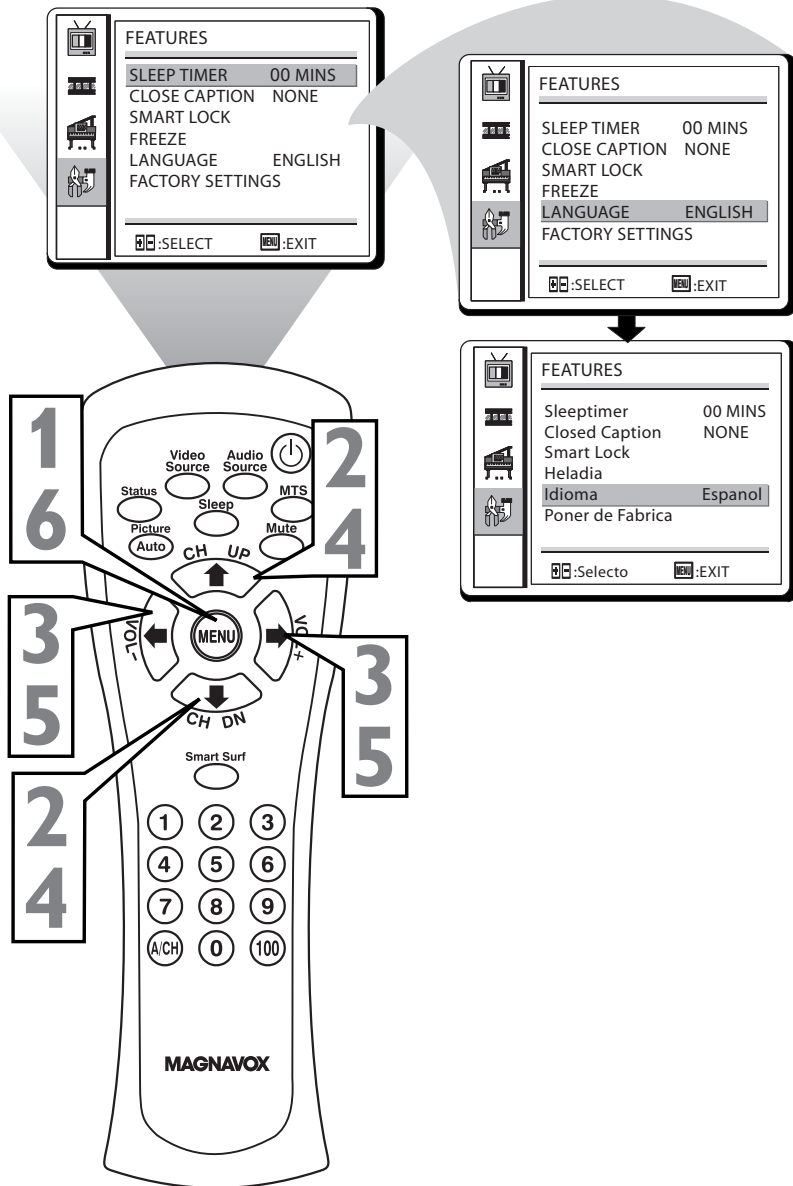

HELPFUL HINT

Remember, the LANGUAGE control makes only the TV's onscreen MENU items appear in English or Spanish text. It does not change the other onscreen text features, such as Closed Captioning (CC), with TV shows.



FACTORY SETTINGS

Your TV can be reset to the factory settings in case you forget your Smart Lock password, or want to change the picture, sound, or features settings.

- 1** Press the **MENU** button on the remote control to see the onscreen menu.
- 2** Press the the **▲(CH UP)** or **▼(CH DN)** buttons to highlight the **FEA-TURES** menu.
- 3** Press the **▶(VOL+)** or **◀(VOL-)** buttons to enter the **FEATURES** menu.
- 4** Press the **▲(CH UP)** or **▼(CH DN)** buttons to highlight the **FACTORY SETTINGS** control.
- 5** Press the **▶(VOL+)** or **◀(VOL-)** buttons to reset the TV to the original factory settings.
- 6** Press the **MENU** button repeatedly to clear the menu from the screen.

NOTE: If you reset the TV to the factory settings, you must make any changes that you had previously made to TV INSTALL, PICTURE, SOUND, AND FEATURES.

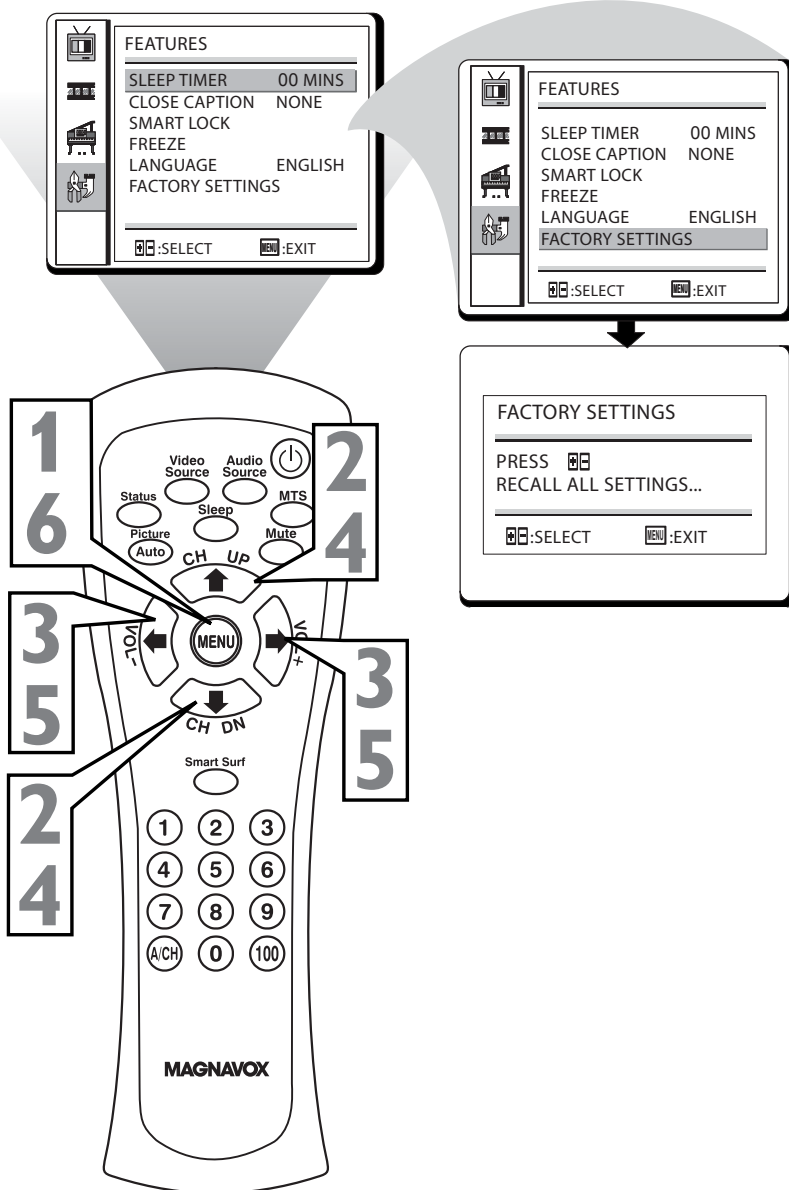



This TV can also be used as a PC Monitor. A PC video signal must be present or the TV will go into standby mode. The Picture controls allow you to adjust the picture.

- 1** Press the **MENU** button on the remote control to see the onscreen menu.
- 2** Press the **▲(CH UP)** or **▼(CH DN)** buttons to highlight the **PICTURE** menu.
- 3** Press the **▶(VOL+)** or **◀(VOL-)** buttons to enter the **PICTURE** menu.
- 4** Press the **▲(CH UP)** or **▼(CH DN)** buttons to highlight the item that you would like to adjust.
- 5** Press the **▶(VOL+)** or **◀(VOL-)** buttons to adjust the item.

NOTE: To adjust other items repeat steps 4 and 5.

- 6** Press **MENU** repeatedly to remove the menu from the screen.

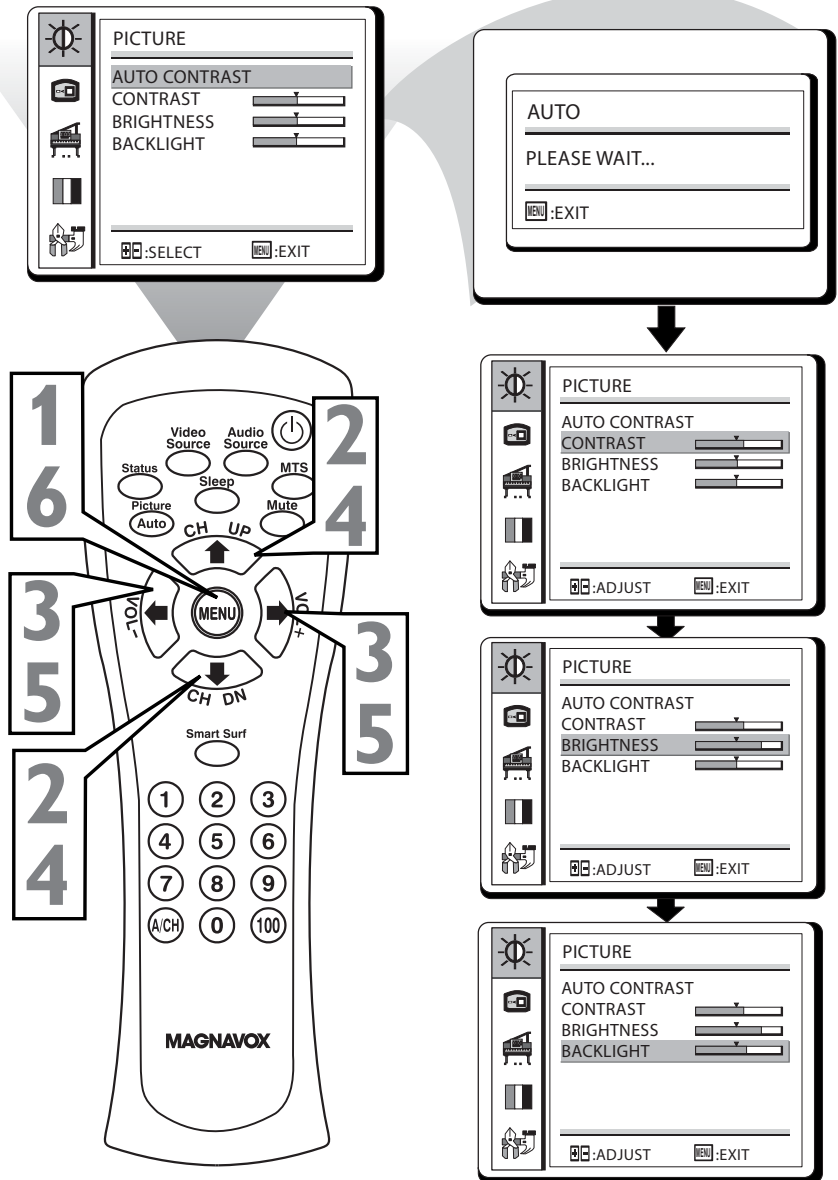

HELPFUL HINTS

Auto Contrast: The LCD Monitor will automatically adjust picture for best contrast.

Contrast: Adjust to “sharpen” the Picture quality. The black portions of the picture become richer in darkness and the white become brighter.

Brightness: Adjust to brighten the darkest parts of the picture.

Backlight: Adjust the brightness of the picture while preserving the picture’s color.



PC IMAGE ADJUSTMENT CONTROLS

This TV can also be used as a PC Monitor. A PC video signal must be present or the TV will go into standby mode. The Image Adjust controls allow you to adjust the image as it appears on the screen.

- 1 Press the **MENU** button on the remote control to see the onscreen menu.
 - 2 Press the the **▲(CH UP)** or **▼(CH DN)** buttons highlight the **IMAGE ADJUST** menu.
 - 3 Press the the **▶(VOL+)** or **◀(VOL-)** buttons to enter the **IMAGE ADJUST** menu.
 - 4 Press the **▲(CH UP)** or **▼(CH DN)** buttons to highlight the item that you would like to adjust.
 - 5 Press the the **▶(VOL+)** or **◀(VOL-)** buttons to adjust the item.
- NOTE:** To adjust other items repeat steps 4 and 5.
- 6 Press **MENU** repeatedly to remove the menu from the screen.

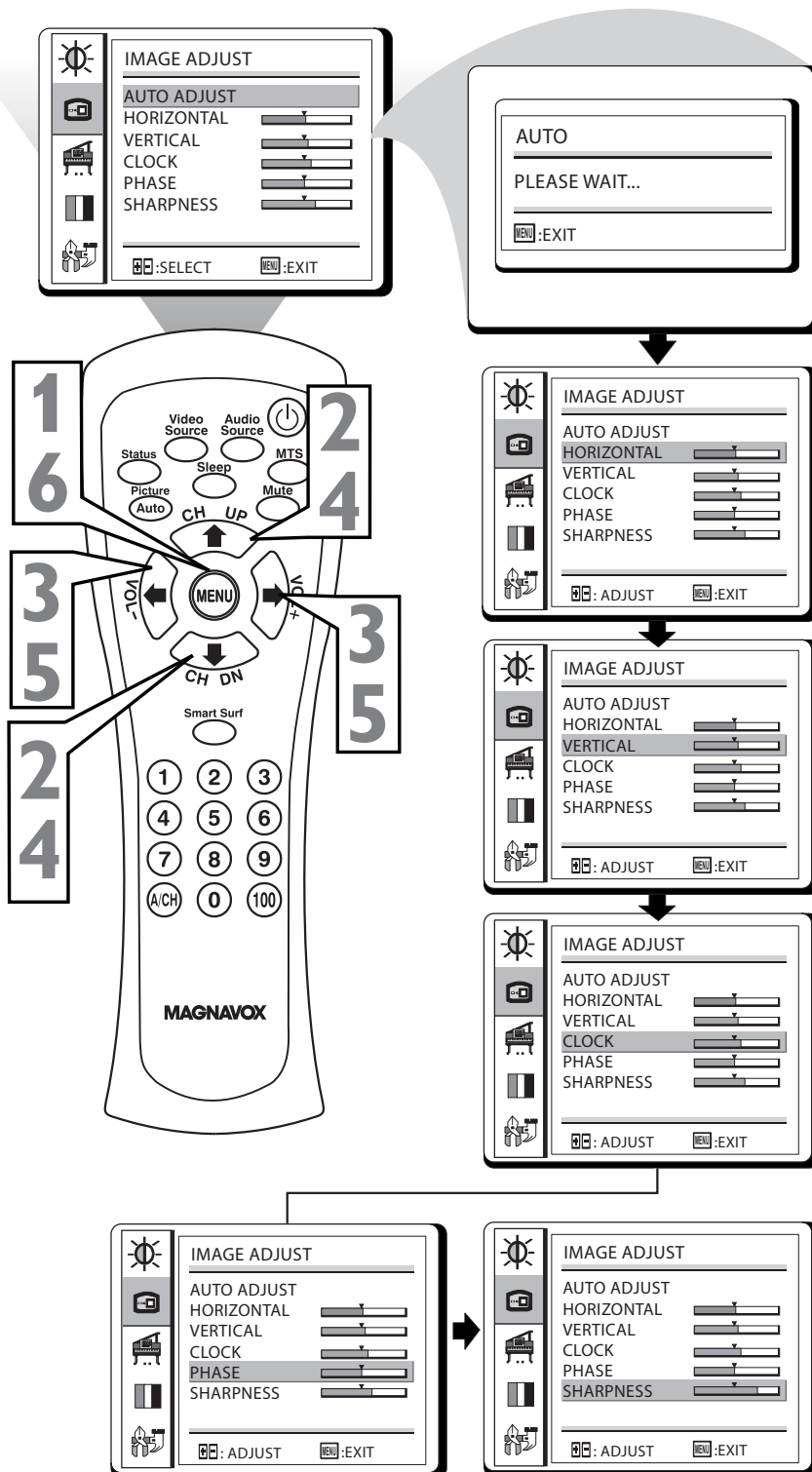

HELPFUL HINTS

Auto Adjust: The LCD Monitor will automatically adjust to the best image position, phase, and clock settings.

Horizontal: Adjusts the horizontal position of the picture.

Vertical: Adjusts the vertical position of the picture.

Clock: Adjusts the color when patterns appear.

Phase: Adjusts the picture to remove the noise or fuzziness.

Sharpness: Adjust to improve detail.



This TV can also be used as a PC Monitor. A PC video signal must be present or the TV will go into standby mode. The Sound controls allow you to adjust the sound.

- 1** Press the **MENU** button on the remote control to show the onscreen menu.
 - 2** Press the **▲(CH UP)** or **▼(CH DN)** buttons to shift the menu to the right to enter the **SOUND** menu.
 - 3** Press the **▶(VOL+)** or **◀(VOL-)** buttons to shift the menu to the right to enter the **SOUND** menu.
 - 4** Press the **▲(CH UP)** or **▼(CH DN)** buttons to highlight the item that you would like to adjust.
 - 5** Press the **▶(VOL+)** or **◀(VOL-)** buttons to adjust the item.
- NOTE:** To adjust other items repeat steps 4 and 5.
- 6** Press **MENU** repeatedly to remove the menu from the screen.

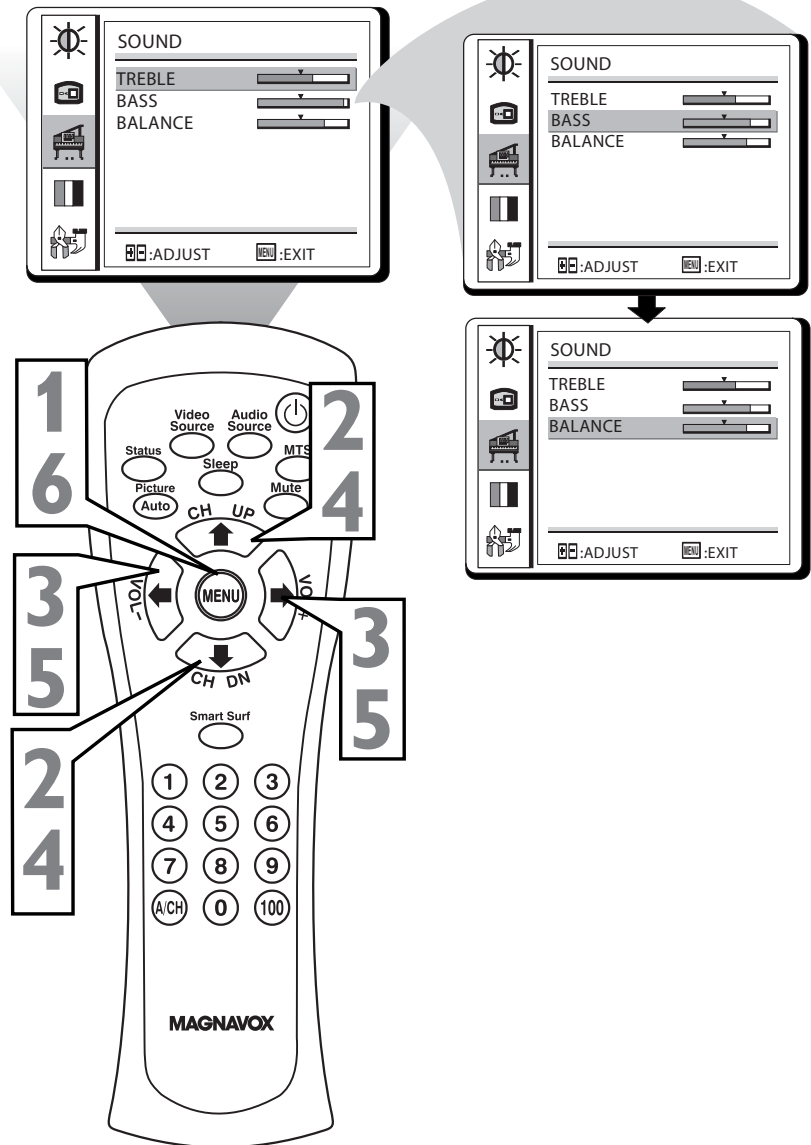

HELPFUL HINTS

Treble: Adjust to enhance the high frequency sounds.

Bass: Adjust to enhance the low frequency sounds.

Balance: Adjusts the level of sounds coming from the left and right speakers.



PC COLOR CONTROLS

This TV can also be used as a PC Monitor. A PC video signal must be present or the TV will go into standby mode. The Color controls allow you to adjust the color.

- 1** Press the **MENU** button on the remote control to see the onscreen menu.
 - 2** Press the **▲(CH UP)** or **▼(CH DN)** buttons to highlight the **COLOR** menu.
 - 3** Press the **▶(VOL+)** or **◀(VOL-)** buttons to enter the **COLOR** menu.
 - 4** Press the **▲(CH UP)** or **▼(CH DN)** buttons to highlight the item that you would like to adjust.
 - 5** Press the **▶(VOL+)** or **◀(VOL-)** buttons to adjust the item.
- NOTE: To adjust other items repeat steps 4 and 5.
- 6** Press **MENU** repeatedly to remove the menu from the screen.

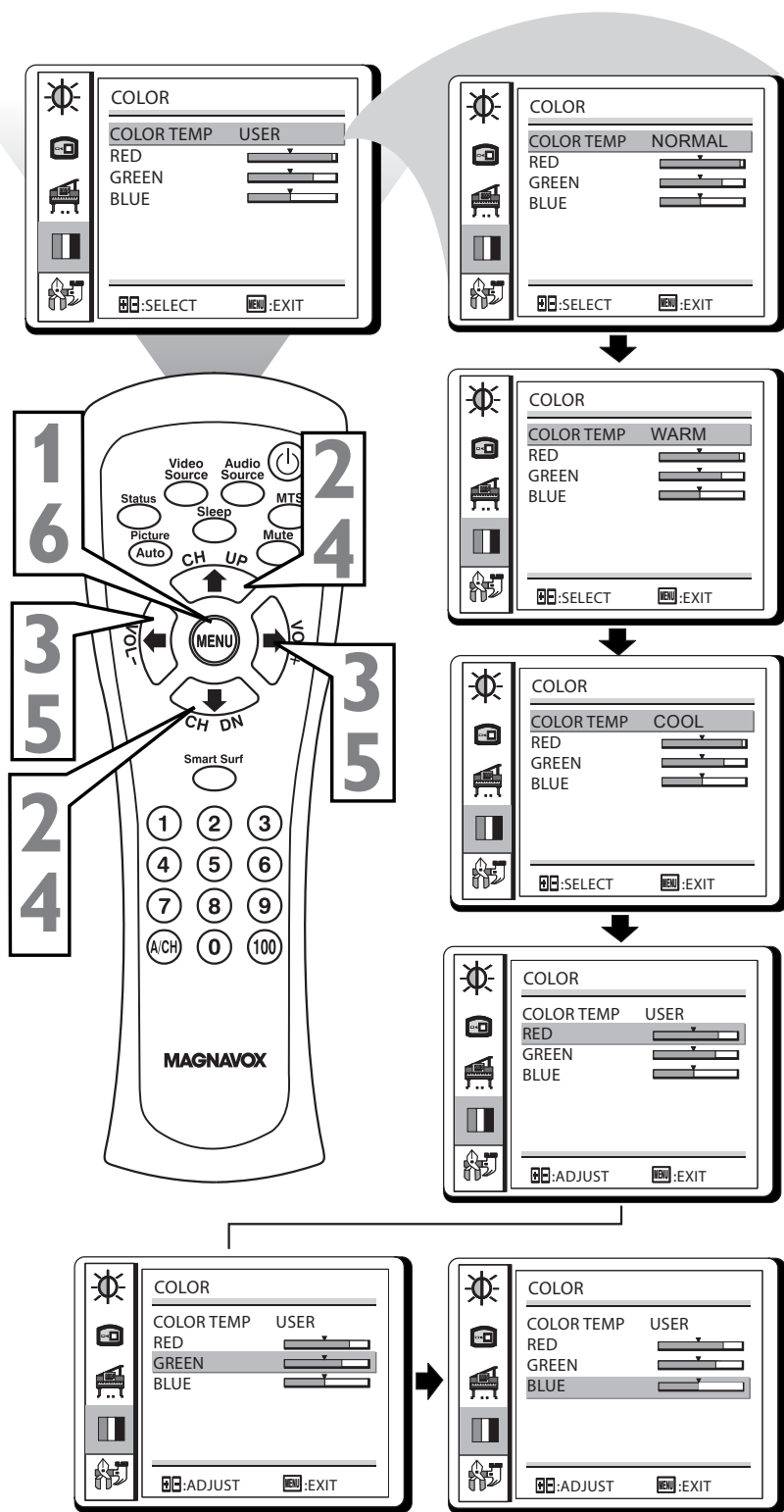

HELPFUL HINTS

Color Temp: Choose from Normal, Warm, Cool, or User preferences.

Red: Adjusts the red color of the picture.

Green: Adjusts the green color of the picture.

Blue: Adjusts the blue color of the picture.



This TV can also be used as a PC Monitor. A PC video signal must be present or the TV will go into standby mode. The Feature controls allow you to adjust the picture.

- 1** Press the **MENU** button to see the onscreen menu.
 - 2** Press the **▲(CH UP)** or **▼(CH DN)** buttons to highlight the **FEATURE** menu.
 - 3** Press the **▶(VOL+)** or **◀(VOL-)** buttons to enter the **FEATURE** menu.
 - 4** Press the **▲(CH UP)** or **▼(CH DN)** buttons to highlight the item that you would like to adjust.
 - 5** Press the **▶(VOL+)** or **◀(VOL-)** buttons to adjust the item.
- NOTE: To adjust other items repeat steps 4 and 5.
- 6** Press **MENU** repeatedly to remove the menu from the screen.

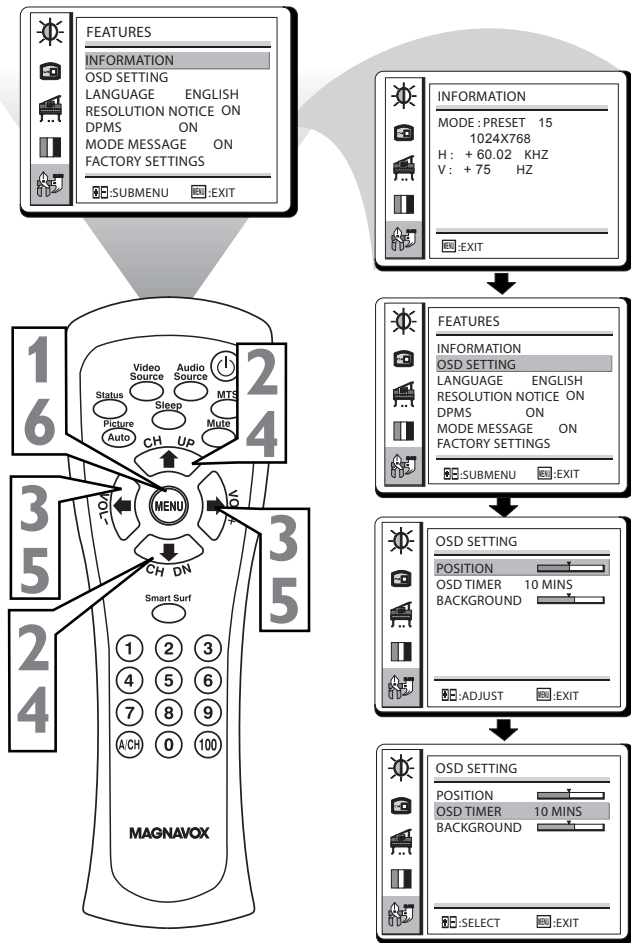

HELPFUL HINTS

Information: Shows the current PC resolution timing with refresh rate.

OSD Setting: Allows you to adjust the position of the picture, the OSD timer, and the background shading.

Language: Allows you to choose an English or Spanish OSD.

Resolution Notice: Shows the current PC resolution timing.

DPMS: (Display Power Management Signaling) When ON, this make the screen black when there is no signal present, or the screen saver has timed out.

Mode Message: When ON, it shows the LCD Monitor's mode. When OFF, it will only show Video and Cable/Air.

Factory Settings: Reverts all picture, sound, color, and feature settings to the original factory settings.

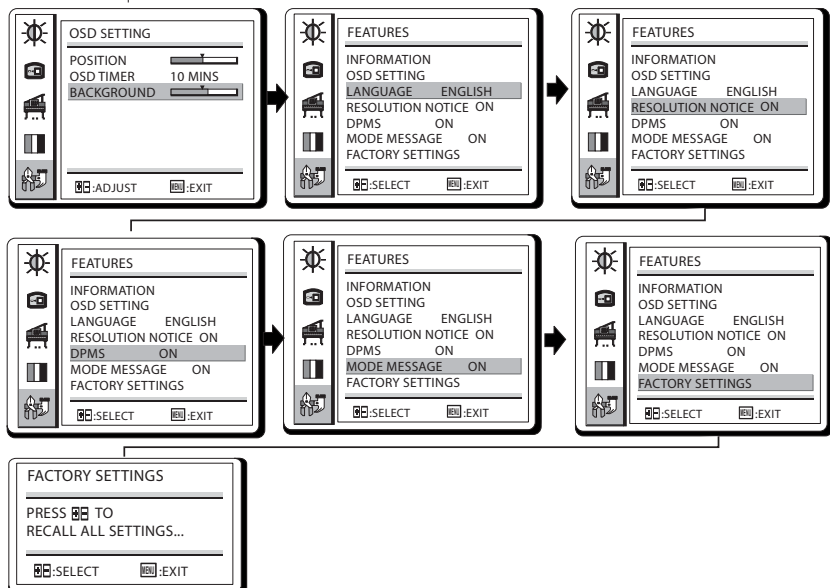



SETTING UP THE PC MODE (PERSONAL COMPUTER MONITOR)

No.	Resolution	Refresh Rate	Vertical Sync	Horizontal Sync	Horizontal Polarity	Pixel Frequency
1	640 x 480	60 Hz	N	31,500 kHz	N	25,175 MHz
2		67 Hz	N	35,000 kHz	N	30,240 MHz
3		72 Hz	N	37,900 kHz	N	31,500 MHz
4		75 Hz	N	37,500 kHz	N	31,500 MHz
5		85 Hz	N	43,300 kHz	N	36,000 MHz
6	720 x 400	70 Hz	P	31,469 kHz	N	28,322 MHz
7	800 x 600	56 Hz	P	35,100 kHz	P	36,000 MHz
8		60 Hz	P	37,900 kHz	P	40,000 MHz
9		72 Hz	P	48,100 kHz	P	50,000 MHz
10		75 Hz	P	46,900 kHz	P	49,500 MHz
11		85 Hz	P	53,700 kHz	P	56,250 MHz
12	832 x 624	75 Hz	P	49,700 kHz	P	57,300 MHz
13	1024 x 768	60 Hz	N	48,400 kHz	N	65,000 MHz
14		70 Hz	N	56,500 kHz	N	75,000 MHz
15		75 Hz	P	60,000 kHz	P	78,750 MHz
16		85 Hz	P	68,700 kHz	P	94,500 MHz
17	1152 x 864	75 Hz	P	67,500 kHz	P	108,000 MHz
18	1280 x 960	60 Hz	P	60,000 kHz	P	108,000 MHz
19	1280 x 1024	60 Hz	P	64,000 kHz	P	108,000 MHz
20		75 Hz	P	80,000 kHz	P	135,000 MHz



No Power

- Check the TV power cord. Disconnect the power cord from the power outlet for 10 seconds, then reinsert the plug into the outlet. Press POWER to turn on the TV again.
- Make sure the outlet is not on a wall switch.
- Make sure a fuse has not blown at the power outlet.

No Picture

- Check the antenna or Cable TV connections. Connect the antenna or Cable TV signal securely to the TV's 75Ω jack on the rear of the TV.
- Set TUNER MODE correctly. Details are on page 12.
- Activate AUTO PROGRAM to find all available channels. Details are on page 13.

No Sound

- Press the VOL+ and VOL- buttons to adjust the volume.
- Press the MUTE button on the remote control to cancel or restore the volume.
- If you have connected other equipment to the TV (such as a VCR or DVD Player), make sure the audio cables are connected securely between the TV and the other equipment.
- Check the SOUND settings. Details are on page 18 or 30.

Remote Control does not work.

- Check the batteries. If necessary, replace them with two AAA heavy duty (zinc chloride) or alkaline batteries.
- Clean the remote control as well as the remote control sensor on the front of the TV.
- Check the TV power cord. Disconnect the power cord from the power outlet for 10 seconds, then reinsert the plug into the outlet. Press POWER to turn on the TV again.
- Make sure the outlet is not on a wall switch.
- Make sure a fuse has not blown at the power outlet.
- Always point the remote control toward the front of the TV (toward the remote sensor).

TV displays wrong channel or no channels.

- Repeat channel selection.
- Add the channel number(s) into the TV's memory. Use STORE. Details are on page 14.
- Make sure TUNER MODE is set correctly. Details are on page 11. Then activate AUTO PROGRAM to set up all available channels. Details are on page 12.



WARNING concerning stationary images on the TV screen: Do not leave fixed images on the screen for extended periods of time. This can cause uneven aging of the picture tube. Normal use of the TV should involve viewing of programs that have constantly moving or changing images. Do not leave nonmoving images on screen for extended periods of time. Do not display the same images too frequently; if you do, subtle “ghost” images can be left on the picture tube. Sources of stationary images may be Laser discs, video games, Compact Discs Interactive (CD-i), or paused Digital Video Discs (DVDs) or videotapes.

Here are some common examples of stationary images:

- DVD menus list DVD content.
- Letterbox black bars appear at the top and bottom of the TV screen when a wide screen (16:9) movie is viewed on a TV with standard (4:3) aspect ratio. This is available with some DVDs.
- Video game images and scoreboards
- Television station logos cause a problem if they are bright and stationary. Moving or low-contrast graphics are less likely to damage the picture tube.
- Stock market tickers may appear at the bottom of the TV screen if the TV programming covers this news.
- Shopping channel logos, pricing displays may be bright and may appear constantly during the show. These are usually in the same location on the TV screen.

TV Location

- To avoid cabinet warping, cabinet color changes, and an increased chance of TV failure, do not place the TV where temperatures can become excessively hot (for example, in direct sunlight or near a heating appliance).
- Allow a free flow of air around the TV.

Cleaning

- To avoid possible shock hazard, remove the TV’s power cord from the electrical outlet before cleaning.
- Regularly dust the TV with a dry, non-scratching duster.
- When cleaning the TV, take care not to scratch or damage the screen surface. Avoid wearing jewelry or using anything abrasive. Do not use household cleaners. Wipe the screen with a clean cloth dampened with water. Use even, easy, vertical strokes when cleaning.
- Gently wipe the cabinet surfaces with a clean cloth or a sponge dampened in a solution of cool, clear water and a mild soap or detergent. Use a clean, dry cloth to dry the wiped surfaces.
- Occasionally vacuum the vents on the rear of the TV.
- Never use thinners, insecticide sprays, or other chemicals on or near the cabinet. They may blemish the cabinet permanently.



Alternate Channel	15
Antenna Connection	7
Audio In jack	8-9
Auto Program	13
Balance	18, 31
Bass	18, 31
Batteries	5
Blocking	21
Brightness	17, 29
Cable Box Connections	8
Cable TV Connection	7
Care and Cleaning	36
Channel Edit (Store)	14
Closed Captions	25
Color	17, 32
Color Temperature	17
Factory Service Information	39-40
Factory Settings	28, 33
Fine Tune	16
Freeze	26
Index	37
Language	27, 33
Limited Warranty	40
Mono	18
No Rating	19
PC (Monitor) Connection	11
Picture Adjustments	17
Registration	2
Remote Control Buttons	6
Remote Control Operation (Basic)	5
Safety Instructions	3
Sharpness	17, 30
Sleep Timer	24
SmartLock	
Access Code	20
Block Enable	21
Movie Rating	19, 22
TV Rating	19, 23
Smart Surf	15
Sound	18, 31
Sound Mode	18
Stereo	18
Store	14
S-Video Connection	10
Table of Contents	4
Tint	17, 30
Treble	18, 31
Troubleshooting	35
Tuner Mode	12
TV Operation (Basic)	5
Unrated	19
Video In jack	8-9
Warranty	40
Welcome	2



FACTORY SERVICE LOCATIONS

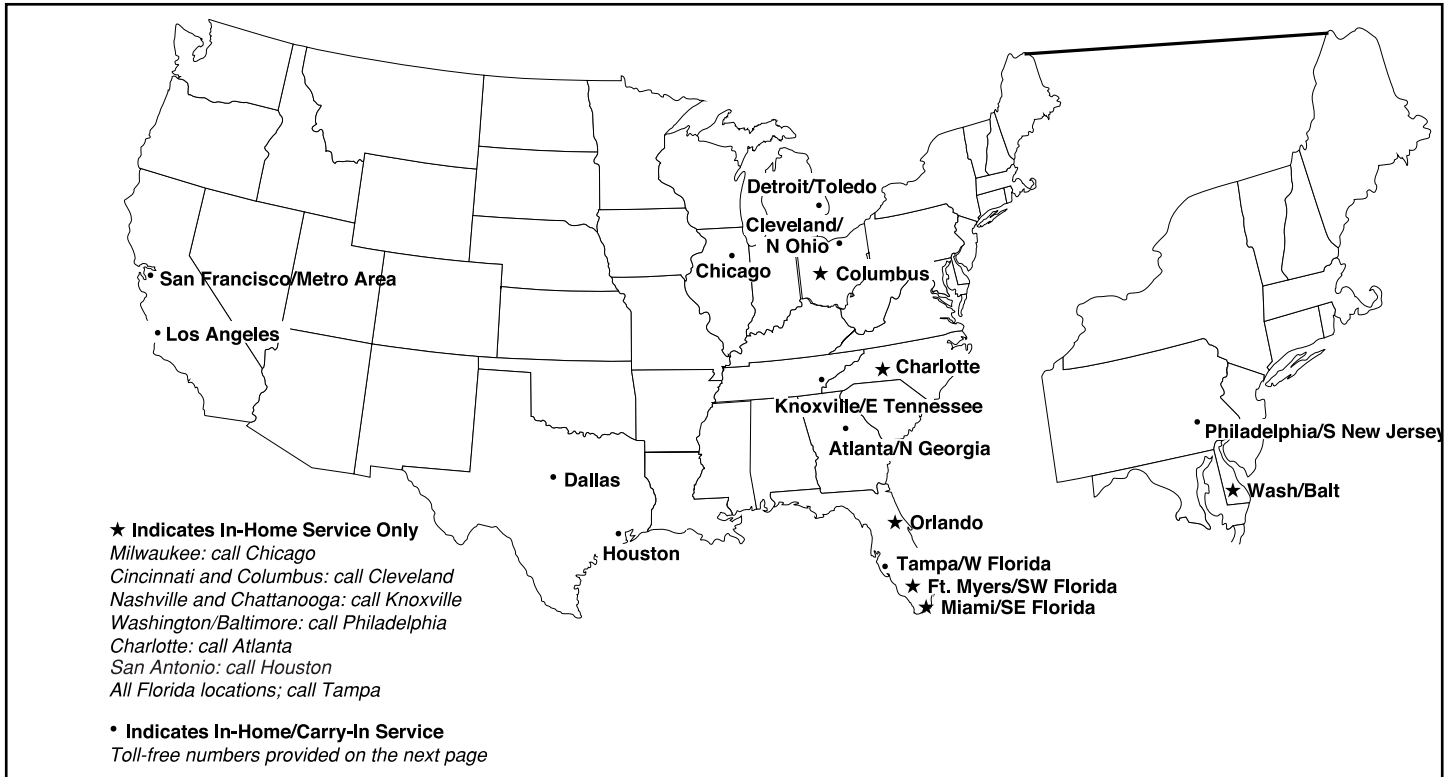

NOTE: Magnavox has chosen Philips Factory Service as its preferred, authorized servicer. Please contact a Philips Factory Service Center. If you reside in one of our Philips Factory Service Branch areas, you can contact the nearest Service Branch to obtain efficient and expedient repair for your product. If your product is In-Warranty, you should have proof-of-purchase to ensure No Charge Service. For Out-of-Warranty service, call the location nearest you.

NOTA: Si vous résidez dans une des régions desservies par une succursale de service après vente du fabricant Philips (voir liste ci-dessous), vous pourrez contacter la branche de service après vente la plus près de chez vous pour obtenir un service après vente rapide et efficace. Si le produit est sous garantie, il suffira de présenter une preuve d'achat pour bénéficier d'un service sans frais. Pour les produits non couverts par la garantie, contactez le centre le plus près de chez vous.

NOTA: Si Ud. reside en una de nuestras zonas para sucursales Philips de servicio al de fábrica (ver directorio más abajo), Ud. puede comunicarse con la sucursal de servicio más cercana para obtener una reparación oportuna y eficaz de su producto. Si su producto está todavía bajo garantía, Ud. debe presentar comprobante de compra para no ocasionar ningunos cargos por servicio. Para servicio después del vencimiento de la garantía, llame al lugar más cercano de los abajo indicados.

In Canada

To obtain efficient and expedient carry-in, mail-in, or in-home service for your product, please contact Magnavox at:

1-800-661-6162 (French speaking)
 1-800-705-2000 (English or Spanish speaking)

Au Canada

Comment obtenir le service après-vente pour les produits apportés ou envoyés par la poste à notre centre de service ou le service à domicile, veuillez contacter Magnavox á:

1-800-661-6162 (Francophone)
 1-800-705-2000 (Anglais ou Espagnol)

En el Canadá

Cómo recibir servicio eficiente para su producto, en persona, por correo o a domicilio, favor de comunicarse con Magnavox al:

1-800-661-6162 (francófono)
 1-800-705-2000 (Inglés o Español)

FACTORY SERVICE LOCATIONS



QUALITY SERVICE IS AS CLOSE AS YOUR TELEPHONE! SIMPLY LOOK OVER THE LIST BELOW FOR THE NUMBER OF A FACTORY SERVICE CENTER NEAR YOU. MAGNAVOX HAS CHOSEN PHILIPS FACTORY SERVICE AS ITS PREFERRED, AUTHORIZED SERVICER. YOUR PRODUCT WILL RECEIVE EFFICIENT AND EXPEDIENT CARRY-IN, MAIL-IN, OR IN-HOME SERVICE, AND YOU WILL RECEIVE PEACE OF MIND, KNOWING YOUR PRODUCT IS BEING GIVEN THE EXPERT ATTENTION OF PHILIPS' FACTORY SERVICE.

COMMENT OBTENIR NOTRE SERVICE APRÈS VENTE RAPIDE ET EFFICACE SOIT PAR COURRIER, À DOMICILE, OU EN SE PRÉSENTANT À UN CENTRE DE SERVICE PHILIPS. PLUS DE 600 CENTRES DE RÉCEPTION DE PRODUITS À RÉPARER À TRAVERS LE PAYS: CONTACTER LE CENTRE DE SERVICE AUX CONSOMMATEURS LE PLUS PROCHE POUR SAVOIR L'EMPLACEMENT DE CES DÉPÔTS DANS UN RAYON DE 50 À 75 MILES (80 KM À 120 KM) DU CENTRE DE SERVICE LOCAL.

CÓMO OBTENER UN SERVICIO OPORTUNO Y EFICIENTE POR CORREO, EN CASA O EN PERSONA PARA SU PRODUCTO A TRAVÉS DE UN CENTRO PHILIPS DE SERVICIO. MAS DE 600 SITIOS POR TODO EL PAIS PARA LA RECEPCION DE PRODUCTOS NECESITADOS DE REPARACIONES: COMUNICARSE CON EL CENTRO DE SERVICIO DE FABRICA MAS CERCANO PARA ESTOS LUGARES DENTRO DE UN RADIO DE 80 A 120 KM (50 A 75 MILLAS) DEL CENTRO DE SERVICIO LOCAL.

ATLANTA

Philips Factory Service
550 Franklin Road., Suite F
Marietta, GA 30067
800-273-1501

TAMPA

Philips Factory Service
1911 US Highway 301 North, Suite 100
Tampa, FL 33619
800-442-2027

SAN FRANCISCO

Philips Factory Service
681 East Brokaw Rd.
San Jose, CA 95112
800-300-9013

HOUSTON

Philips Factory Service
1110 N. Post Oak Rd., Suite 100
Houston, TX 77055
800-952-3254

CLEVELAND

Philips Factory Service
950 Keynote Circle
Brooklyn Heights, OH 44131
800-331-7037

DETROIT

Philips Factory Service
25173 Dequindre
Madison Heights, MI 48071
800-438-1398

DALLAS

Philips Factory Service
415 N. Main Street, #107
Euless, TX 76040
800-952-3254

LOS ANGELES

Philips Factory Service
20930 Bonita, Ste. V
Carson, CA 90746
800-300-9013

CHICAGO

Philips Factory Service
1279 W. Hamilton Pkwy.
Itasca, IL 60143
800-531-2922

KNOXVILLE

Philips Factory Service
One Philips Drive
Building 2
Knoxville, TN 37914
800-821-1767

PHILADELPHIA

Philips Factory Service
354 Dunks Ferry Rd.
Bensalem, PA 19020
800-847-9320



LIMITED WARRANTY

LCD TV MONITOR

90 Days Free Labor

One Year Parts Exchange

This product must be carried in for service.

WHO IS COVERED?

You must have proof of purchase to receive warranty service. A sales receipt or other document showing that you purchased the product is considered proof of purchase.

WHAT IS COVERED?

Warranty coverage begins the day you buy your product. ~~For 90 days~~ ~~the after~~, all parts will be repaired or replaced free, and labor is free. From 90 days to one year from the day of purchase, all parts will be repaired or replaced free, but you pay for all labor charges. After one year from the day of purchase, you pay for the replacement or repair of all parts, and for all labor charges.

All parts, including repaired and replaced parts, are covered only for the original warranty period. When the warranty on the product expires, the warranty on all replaced and repaired parts also expires.

WHAT IS EXCLUDED?

Your warranty does not cover:

- labor charges for installation or setup of the product, adjustment of customer controls on the product, and installation or repair of antenna systems outside of the product.
- product repair and/or part replacement because of misuse, accident, unauthorized repair or other cause not within the control of Magnavox.
- reception problems caused by signal conditions or cable or antenna systems outside the unit.
- a product that requires modification or adaptation to enable it to operate in any country other than the country for which it was designed, manufactured, approved and/or authorized, or repair of products damaged by these modifications.
- incidental or consequential damages resulting from the product. (Some states do not allow the exclusion of incidental or consequential damages, so the above exclusion may not apply to you. This includes, but is not limited to, prerecorded material, whether copyrighted or not copyrighted.)
- a product used for commercial or institutional purposes.

WHERE IS SERVICE AVAILABLE?

Warranty service is available in all countries where the product is officially distributed by Magnavox. In countries where Magnavox does not distribute the product, the local Magnavox service organization will attempt to provide service (although there may be a delay if the appropriate spare parts and technical manual(s) are not readily available).

MAKE SURE YOU KEEP...

Please keep your sales receipt or other document showing proof of purchase. Attach it to this owner's manual and keep both nearby. Also keep the original box and packing material in case you need to return your product.

BEFORE REQUESTING SERVICE...

Please check your owner's manual before requesting service. Adjustments of the controls discussed there may save you a service call.

TO GET WARRANTY SERVICE IN U.S.A., PUERTO RICO, OR U.S. VIRGIN ISLANDS...

Contact a Magnavox factory service center (see enclosed list) or authorized service center to arrange repair.

(In U.S.A., Puerto Rico, and U.S. Virgin Islands, all implied warranties, including implied warranties of merchantability and fitness for a particular purpose, are limited in duration to the duration of this express warranty. But, because some states do not allow limitations on how long an implied warranty may last, this limitation may not apply to you.)

TO GET WARRANTY SERVICE IN CANADA...

Please contact Magnavox at:

1-800-705-2000

(In Canada, this warranty is given in lieu of all other warranties. No other warranties are expressed or implied, including any implied warranties of merchantability or fitness for a particular purpose. Magnavox is not liable under any circumstances for any direct, indirect, special, incidental or consequential damages, howsoever incurred, even if notified of the possibility of such damages.)

REMEMBER...

Please record below the model and serial numbers found on the product. Also, please fill out and mail your warranty registration card promptly. It will be easier for us to notify you if necessary.

MODEL # _____

SERIAL # _____

This warranty gives you specific legal rights. You may have other rights which vary from state/province to state/province.

Magnavox, P.O. Box 520890, Miami, FL 33152 (402) 536-4171
EL6541E002