

STARPLUS®

96 EX

HYBRID KEY TELEPHONE SYSTEM

GENERAL DESCRIPTION,
INSTALLATION AND
MAINTENANCE MANUAL



QUICK REFERENCE TABLE OF CONTENTS

SECTION 100	INTRODUCTION	100-1
SECTION 200	GENERAL DESCRIPTION	200-1
SECTION 300	FEATURE DESCRIPTION	300-1
SECTION 400	FEATURE OPERATION	400-1
SECTION 500	INSTALLATION	500-1
SECTION 600	CUSTOMER DATA BASE PROGRAMMING	600-1
SECTION 700	SYSTEM CHECKOUT	700-1
SECTION 800	MAINTENANCE AND TROUBLESHOOTING	800-1

TABLE OF CONTENTS

SECTION 100	INTRODUCTION	100-1
100.1	PURPOSE	100-1
100.2	REGULATORY INFORMATION (USA)	100-1
100.3	REGULATORY INFORMATION (CANADIAN)	100-2
100.4	UL/CSA SAFETY COMPLIANCE	100-3
SECTION 200	FEATURE DESCRIPTION	200-1
200.1	ACCOUNT CODES	200-1
200.2	AMPLIFIED CENTRAL OFFICE BOARD	200-1
200.3	ATTENDANT RECALL	200-1
200.4	AUTOMATIC LINE ACCESS	200-1
200.5	AUTOMATIC NIGHT SERVICE	200-1
200.6	AUTOMATIC PAUSE INSERTION WITH SPEED DIAL	200-1
200.7	AUTOMATIC PRIVACY	200-1
200.8	AUTOMATIC SELECTION	200-1
200.9	BACKGROUND MUSIC	200-1
200.10	BASIC KEYSER COMPATIBILITY	200-1
200.11	BATTERY BACK-UP (MEMORY)	200-1
200.12	BATTERY BACK-UP (SYSTEM)	200-7
200.13	BUSY LAMP FIELD (BLF)	200-7
200.14	CALL ANNOUNCE - PRIVACY	200-7
200.15	CALL BACK	200-7
200.16	CALL FORWARD: STATION	200-7
200.17	CALL FORWARD: PRESET	200-7
200.18	CALLING STATION TONE MODE OPTION	200-8
200.19	CALL PARK	200-8
200.20	CALL PICK-UP:	200-8
200.21	CALL TRANSFER	200-8
200.22	CAMP-ON	200-8
200.23	CAMP-ON RECALL	200-8
200.24	CANNED TOLL RESTRICTION	200-8
200.25	CENTREX COMPATIBILITY	200-8
200.26	CENTREX/PBX TRANSFER	200-9
200.27	CHAINING SPEED BINS	200-9
200.28	CO LINE ACCESS	200-9
200.29	CO LINE CLASS OF SERVICE	200-9
200.30	CO LINE CONTROL (CONTACT)	200-9
200.31	CO LINE GROUPS	200-9
200.32	CO LINE LOOP SUPERVISION	200-9
200.33	CO LINE QUEUE	200-9
200.34	CO LINE INCOMING RINGING ASSIGNMENT	200-9
200.35	CO RING DETECT	200-10
200.36	CONFERENCE	200-10
200.37	CONFERENCE ENABLE/DISABLE	200-10
200.38	DATA BASE PRINTOUT (DUMP)	200-10
200.39	DAY/NIGHT CLASS OF SERVICE (COS)	200-10
200.40	DEFAULT BUTTON MAPPING	200-10
200.41	DIAL PULSE SENDING	200-10
200.42	DIALING PRIVILEGES	200-10
200.43	DIRECT INWARD SYSTEM ACCESS (DISA)	200-10
200.44	DIRECT STATION SELECTION	200-12

200.45	DIRECTED CALL PICKUP	200-12
200.46	DISABLE OUTGOING CO LINE ACCESS	200-12
200.47	DO NOT DISTURB (DND)	200-12
200.48	DTMF SENDING	200-12
200.49	EMERGENCY TRANSFER	200-12
200.50	END TO END SIGNALLING	200-12
200.51	EXCLUSIVE HOLD	200-12
200.52	EXECUTIVE OVERRIDE	200-12
200.53	EXECUTIVE/SECRETARY TRANSFER	200-13
200.54	EXTERNAL NIGHT RINGING	200-13
200.55	FLASH	200-13
200.56	FLASH ON INTERCOM	200-13
200.57	FLASH WITH SPEED DIAL	200-13
200.58	FLEXIBLE ATTENDANT	200-13
200.59	FLEXIBLE BUTTON ASSIGNMENT	200-13
200.60	FORCED ACCOUNT CODES	200-13
200.61	FORCED LEAST COST ROUTING (LCR)	200-13
200.62	GROUP CALL PICK-UP	200-14
200.63	HEADSET COMPATIBILITY	200-14
200.64	HEADSET MODE	200-14
200.65	HEARING AID COMPATIBLE	200-14
200.66	HOLD PREFERENCE	200-14
200.67	HOLD RECALL	200-14
200.68	HOT LINE	200-14
200.69	HUNT GROUPS	200-14
200.70	INCOMING CO LINES OFF-NET FORWARD (VIA SPEED DIAL)	200-14
200.71	INTERCOM CALLING	200-14
200.72	INTERCOM SIGNALING SELECT	200-14
200.73	LAST NUMBER REDIAL (LNR)	200-15
200.74	LCD INTERACTIVE DISPLAY	200-15
200.75	LEAST COST ROUTING (LCR)	200-15
200.76	LOOP BUTTON CO LINE ACCESS	200-16
200.77	LOUD BELL CONTROL (LBC)	200-16
200.78	MEET ME PAGE	200-16
200.79	MESSAGE WAITING	200-16
200.80	MESSAGE WAITING REMINDER TONE	200-16
200.81	MUSIC ON HOLD	200-16
200.82	MUTE KEY	200-16
200.83	NAME IN LCD DISPLAY	200-16
200.84	NIGHT SERVICE	200-16
200.85	OFF-HOOK PREFERENCE	200-17
200.86	OFF-HOOK SIGNALLING	200-17
200.87	OFF-PREMISE EXTENSIONS (OPX)	200-17
200.88	ON HOOK DIALING	200-17
200.89	ON LINE PROGRAMMING	200-17
200.90	PAGING	200-17
200.91	PAUSE TIMER	200-18
200.92	PBX DIALING CODES	200-18
200.93	PERSONALIZED MESSAGES	200-18
200.94	PHONE BOX	200-18
200.95	POOL BUTTON OPERATION	200-18
200.96	PREFERRED LINE ANSWER	200-18
200.97	PRIVACY RELEASE	200-18
200.98	PRIVATE LINE	200-18

200.99	PULSE-TO-TONE SWITCHOVER	200-19
200.100	RANGE PROGRAMMING	200-19
200.101	REMOTE ADMINISTRATION	200-19
200.102	REMOTE SYSTEM MONITOR AND MAINTENANCE	200-19
200.103	SAVE NUMBER REDIAL (SNR)	200-19
200.104	SINGLE LINE TELEPHONE (SLT) COMPATIBILITY	200-19
200.105	STATION MESSAGE DETAIL RECORDING (SMDR)	200-19
200.106	SPEAKERPHONE	200-19
200.107	STATION CLASS OF SERVICE	200-19
200.108	STATION SPEED DIAL	200-20
200.109	SYSTEM CAPACITY	200-20
200.110	SYSTEM HOLD	200-20
200.111	SYSTEM SPEED DIAL	200-20
200.112	TOLL RESTRICTION (TABLE DRIVEN)	200-20
200.113	TRANSFER RECALL	200-20
200.114	UNIFORM CALL DISTRIBUTION (UCD)	200-20
200.115	UNIVERSAL NIGHT ANSWER (UNA)	200-21
200.116	VOICE MAIL GROUPS (VM)	200-21
200.117	VOLUME CONTROLS	200-21
200.118	ACCOUNT CODE	200-22
200.119	AUTOMATIC LINE ACCESS	200-22
200.120	CALL FORWARD	200-22
200.121	CAMP ON	200-22
200.122	CONFERENCE	200-22
200.123	CONFERENCE /WITH PERSONAL PARK	200-22
200.124	DIRECT OUTSIDE LINE ACCESS	200-22
200.125	DIRECT OUTSIDE LINE RINGING	200-22
200.126	DIRECTED CALL PICK UP	200-22
200.127	DO NOT DISTURB	200-22
200.128	GROUP CALL PICK UP	200-22
200.129	INTERCOM CALLING	200-22
200.130	MESSAGE WAITING/CALL BACK	200-22
200.131	MESSAGE WAITING INDICATION	200-22
200.132	NIGHT SERVICE	200-23
200.133	OFF-HOOK PREFERENCE	200-23
200.134	PERSONAL PARK	200-23
200.135	QUEUING	200-23
200.136	STATION SPEED DIAL	200-23
200.137	SYSTEM SPEED DIAL	200-23
200.138	TRANSFER	200-23
200.139	ATTENDANT DISABLE OUTGOING ACCESS	200-23
200.140	ATTENDANT OVERFLOW	200-23
200.141	ATTENDANT OVERRIDE	200-23
200.142	ATTENDANT POSITION	200-23
200.143	ATTENDANT RECALL	200-23
200.144	AUTOMATIC NIGHT MODE	200-23
200.145	INCOMING CO LINE OFF-NET FOR-WARD	200-24
200.146	TIME AND DATE PROGRAMMING	200-24
200.147	ATTENDANT SEARCH	200-24
200.148	BUSY LAMP FIELD INDICATORS	200-24
200.149	DIRECT STATION CALLING	200-24
200.150	MAPPING OPTIONS	200-24
200.151	RELEASE KEY	200-24

SECTION 300	FEATURE OPERATION	300-1
300.1	INTRODUCTION	300-1
300.2	KEY TELEPHONE STATION FEATURES	300-1
300.3	ANSWERING AN OUTSIDE CALL	300-4
300.4	PLACING AN OUTSIDE CALL ON HOLD	300-4
300.5	ANSWERING A RECALL	300-4
300.6	ACCOUNT CODES	300-4
300.7	DISABLE OUTGOING CO LINE ACCESS	300-4
300.8	PLACING AN OUTSIDE CALL (Automatic Line Selection)	300-4
300.9	BACKGROUND MUSIC (Optional)	300-4
300.10	AUTOMATIC SELECTION	300-4
300.11	CALL BACK	300-4
300.12	CALL FORWARD: STATION	300-4
300.13	CALL FORWARD: PRESET	300-6
300.14	CALL FORWARD: CO LINES	300-6
300.15	CALLING STATION TONE MODE OPTION	300-6
300.16	CALL PARK	300-6
300.17	CALL PICK-UP: GROUP	300-7
300.18	CALL TRANSFER	300-7
300.19	TRANSFERRING CO CALLS TO A STATION FORWARDED TO VM	300-7
300.20	CAMP-ON	300-7
300.21	CO LINE ACCESS	300-8
300.22	QUEUING	300-8
300.23	CONFERENCE COMBINATIONS	300-8
300.24	DIRECTED CALL PICK-UP	300-8
300.25	DIRECT INWARD SYSTEM ACCESS (DISA)	300-9
300.26	DO NOT DISTURB	300-9
300.27	EXCLUSIVE HOLD	300-9
300.28	EXECUTIVE OVERRIDE	300-9
300.29	EXECUTIVE/SECRETARY TRANSFER	300-10
300.30	FLASH	300-10
300.31	FLASH ON INTERCOM	300-10
300.32	FLEXIBLE BUTTON ASSIGNMENT	300-10
300.33	HEADSET MODE	300-11
300.34	INTERCOM CALLING	300-11
300.35	INTERCOM TRANSFER	300-11
300.36	LAST NUMBER REDIAL	300-11
300.37	LEAST COST ROUTING	300-12
300.38	LCR QUE CANCEL	300-12
300.39	MEET ME PAGE	300-12
300.40	MESSAGE WAITING	300-12
300.41	MUTE KEY	300-12
300.42	OFF-HOOK PREFERENCE	300-12
300.43	PAGING	300-12
300.44	PBX/CENTREX TRANSFER	300-13
300.45	PERSONALIZED MESSAGES	300-13
300.46	PERSONALIZED MESSAGE CODE ON A FLEX KEY	300-13
300.47	PHONE BOX RINGING	300-13
300.48	PRIME FLEX BUTTON PROGRAMMING	300-13
300.49	PROGRAMMING YOUR NAME INTO THE LCD DISPLAY	300-13
300.50	PULSE TO TONE SWITCHOVER	300-14
300.51	SAVE NUMBER REDIAL	300-14
300.52	PROGRAMMING PBX/CENTREX CODES ONTO A FLEX BUTTON	300-14
300.53	SPEAKERPHONE	300-14

300.54	STATION SPEED DIAL	300-14
300.55	STORING SPEED NUMBERS	300-14
300.56	SYSTEM SPEED DIAL	300-15
300.57	UNIFORM CALL DISTRIBUTION (UCD)	300-15
300.58	UNIVERSAL NIGHT ANSWER(UNA)	300-15
300.59	VOICE MAIL OPERATION (VM)	300-15
300.60	VOLUME CONTROLS	300-16
300.61	ACCOUNT CODE	300-16
300.62	CALL BACK	300-16
300.63	CALL FORWARDING	300-16
300.64	CALLING STATION TONE MODE OPTION	300-16
300.65	CAMP-ON	300-16
300.66	CALL PARK (System)	300-16
300.67	CALL TRANSFER:	300-16
300.68	CLEAR CALL FORWARD, DND, PERSONALIZED MESSAGES	300-17
300.69	CO LINE QUEUING	300-17
300.70	CONFERENCE	300-17
300.71	CONFERENCE WITH PERSONAL PARK	300-17
300.72	DIRECT OUTSIDE LINE ACCESS	300-17
300.73	DIRECTED CALL PICK-UP	300-17
300.74	DO NOT DISTURB	300-17
300.75	PBX/CENTREX TRANSFER (Flash Command to CO Line)	300-17
300.76	GROUP CALL PICK-UP	300-17
300.77	PLACING CALLS ON HOLD	300-17
300.78	INTERCOM CALLING	300-18
300.79	LCR QUEUING (Automatic)	300-18
300.80	LCR QUE CALL BACK	300-18
300.81	LCR CANCEL	300-18
300.82	MESSAGE WAITING	300-18
300.83	OFF-HOOK PREFERENCE	300-18
300.84	PERSONALIZED MESSAGES	300-18
300.85	PAGING	300-18
300.86	PERSONAL PARK (Flip-Flop)	300-18
300.87	PROGRAMMING YOUR NAME INTO THE LCD DISPLAY	300-19
300.88	STATION SPEED DIAL	300-19
300.89	STORING STATION SPEED NUMBERS	300-19
300.90	SYSTEM SPEED DIAL	300-19
300.91	UNIVERSAL NIGHT ANSWER (UNA)	300-19
300.92	UCD AVAILABLE/UNAVAILABLE	300-19
300.93	ANSWERING AN OUTSIDE CALL	300-19
300.94	PLACING OUTSIDE LINE ON HOLD	300-19
300.95	ANSWERING A RECALLING OUTSIDE LINE	300-19
300.96	ATTENDANT ACTIVATION OF BGM AT A PHONE BOX	300-19
300.97	ATTENDANT DISABLE OUTGOING ACCESS	300-20
300.98	ATTENDANT OVERRIDE	300-20
300.99	ATTENDANT RECALL	300-20
300.100	EXECUTIVE OVERRIDE	300-20
300.101	INTERCOM CALLING	300-20
300.102	INCOMING CO LINES OFF-NET (via speed dial)	300-20
300.103	NIGHT SERVICE	300-21
300.104	SETTING SYSTEM TIME AND DATE	300-21
300.105	STORING SYSTEM SPEED NUMBERS	300-21
300.106	ATTENDANT TRANSFER SEARCH	300-21
300.107	PLACING AN OUTSIDE CALL (Automatic Line Selection)	300-21

300.108	CALL PARK	300-21
300.109	DO NOT DISTURB INDICATION	300-21
300.110	RETRIEVING A PARKED CALL	300-22
300.111	CALL TRANSFER	300-22
300.112	CAMP-ON	300-22
300.113	Flexible Button Programming	300-22
300.114	MEET ME PAGE	300-22
300.115	PAGING	300-22
300.116	RELEASE BUTTON	300-22
310.1	LCD Displays	310-1
SECTION 400	GENERAL DESCRIPTION	400-1
400.1	SYSTEM TECHNOLOGY	400-1
400.2	COMMON EQUIPMENT	400-1
400.3	PORT CARDS	400-3
400.4	OPTIONAL COMPONENTS	400-4
400.5	STATIONS	400-4
400.6	SYSTEM CAPACITY	400-6
400.7	SYSTEM SPECIFICATIONS	400-6
400.8	MEAN TIME BETWEEN FAILURE (MTBF)	400-16
SECTION 500	INSTALLATION	500-1
500.1	SITE PLANNING	500-1
500.2	UNPACKING THE 96EX BASIC SYSTEM	500-1
500.3	SYSTEM GROUNDING	500-2
500.4	KSU INSTALLATION	500-2
500.5	LIGHTNING PROTECTION	500-5
500.6	EXTERNAL POWER SUPPLY HOUSING 2 (EPH2) INSTALLATION	500-5
500.7	POWER SUPPLY (PS) INSTALLATION	500-5
500.8	BATTERY BACK UP INSTALLATION	500-5
500.9	PRINTED CIRCUIT BOARD INSTALLATION	500-8
500.10	CO/PBX CONNECTIONS	500-11
500.11	AMPLIFIED CENTRAL OFFICE INTERFACE BOARD	500-11
500.12	STATION CONNECTIONS	500-11
500.13	POWER FAILURE TRANSFER AND LBC CONNECTIONS	500-11
500.14	KEY TELEPHONE INSTALLATION	500-19
500.15	DSS/DLS INSTALLATION	500-19
500.16	PHONE BOX INSTALLATION	500-19
500.17	SINGLE LINE TELEPHONE INSTALLATION	500-19
500.18	OFF-PREMISE EXTENSION INSTALLATION (OPX)	500-21
500.19	WALL MOUNTING THE TELEPHONE	500-21
500.20	HEADSET INSTALLATION	500-23
500.21	APPLICATION BOARD (APL) CONNECTIONS	500-23
500.22	INSTALLING THE SINGLE LINE TELEPHONE DTMFRS UNIT (SLU)	500-23
500.23	INSTALLING THE RSM (Additional RS-232C port)	500-23
500.24	RS-232C CONNECTIONS	500-28
500.25	BACKGROUND MUSIC AND MUSIC-ON-HOLD	500-28
500.26	RING GENERATOR AND MESSAGE WAITING POWER SUPPLY UNIT	500-28
500.27	INSTALLING THE EXPANSION KSU	500-28
SECTION 600	CUSTOMER DATA BASE PROGRAMMING	600-1
600.1	INTRODUCTION	600-1
600.2	PROGRAM MODE ENTRY (Data Terminal)	600-1
600.3	PROGRAM MODE ENTRY (Key Station)	600-7

600.4	INITIALIZATION	600-7
600.5	CUSTOMER DATA WORKSHEETS	600-7
600.6	DATA BASE FIELDS	600-7
SECTION 610	SYSTEM PARAMETERS PROGRAMMING	610-1
610.1	SYSTEM HOLD RECALL TIMER	610-1
610.2	EXCLUSIVE HOLD RECALL TIMER	610-1
610.3	TRANSFER RECALL TIMER	610-2
610.4	PRESET FORWARD TIMER	610-2
610.5	PAUSE TIMER	610-3
610.6	CALL PARK RECALL TIMER	610-3
610.7	CONFERENCE TIMER	610-4
610.8	MESSAGE WAIT REMINDER TONE	610-4
610.9	PAGING TIMEOUT TIMER	610-5
610.10	CO RING DETECT TIMER	610-5
610.11	HOLD PREFERENCE	610-6
610.12	EXEC OVERRIDE WARNING TONE	610-6
610.13	EXTERNAL NIGHT RING	610-7
610.14	ATTENDANT OVERRIDE	610-7
610.15	ATTENDANT STATION	610-8
610.16	LOUD BELL CONTROL	610-8
610.17	PBX DIALING CODES	610-9
610.18	EXECUTIVE/SECRETARY PAIRS	610-9
610.19	UNIFORM CALL DISTRIBUTION (UCD)	610-10
610.20	STATION MESSAGE DETAIL RECORDING (SMDR)	610-12
610.21	SET ADMIN. PASSWORD	610-14
610.22	DIAL PULSE PARAMETERS	610-14
610.23	LCR ENABLE	610-15
610.24	DISA ACCESS CODE	610-15
610.25	PHONE BOX RING TIMER	610-16
610.26	ATTENDANT DEDICATED INTERCOM	610-16
610.27	MUSIC CHANNEL	610-17
610.28	SETTING SYSTEM TIME AND DATE	610-17
610.29	SLT HOOKSWITCH TIMER	610-18
610.30	SLT HOOKSWITCH BOUNCE TIMER	610-18
610.31	PAGE WARNING TONE	610-19
610.32	ATTENDANT RECALL TIMER	610-19
610.33	UCD TIMERS	610-20
610.34	ANNOUNCEMENT TABLES	610-22
610.35	CALL FORWARD NO ANSWER TIMER	610-23
610.36	VOICE MAIL GROUPS	610-24
610.37	VOICE MAIL OUTPULSING TABLE	610-26
610.38	HUNT GROUPS	610-28
610.39	WEEKLY NIGHT MODE SCHEDULE	610-29
610.40	SLT DTMF RECEIVER TIMER	610-30
610.41	VOICE MAIL IN-BAND DIGITS	610-30
SECTION 620	CO LINE ATTRIBUTES PROGRAMMING	620-1
620.1	CO LINE PROGRAMMING	620-1
SECTION 630	STATION ATTRIBUTES PROGRAMMING	630-1
630.1	STATION PROGRAMMING	630-1

SECTION 640	EXCEPTION TABLES PROGRAMMING	640-1
640.1	INTRODUCTION	640-1
640.2	RELATED ITEMS TO TOLL RESTRICTION	640-2
640.3	TOLL RESTRICTION PROGRAMMING	640-3
SECTION 650	LEAST COST ROUTING PROGRAMMING	650-1
SECTION 660	SYSTEM DATA BASE PRINTOUTS	660-1
660.1	PRINT ENTIRE SYSTEM DATA BASE	660-1
660.2	SYSTEM PARAMETERS	660-2
660.3	CO LINE ATTRIBUTES	660-5
660.4	STATION ATTRIBUTES	660-7
660.5	EXCEPTION TABLES	660-9
660.6	SYSTEM SPEED DIAL	660-11
660.7	LCR TABLES	660-13
SECTION 700	SYSTEM CHECKOUT	700-1
700.1	INTRODUCTION	700-1
700.2	PRELIMINARY PROCEDURES	700-1
700.3	POWER UP SEQUENCE	700-1
SECTION 800	MAINTENANCE AND TROUBLESHOOTING	800-1
800.1	PRINTED CIRCUIT BOARD (PCB) TROUBLESHOOTING CHARTS	800-1
800.2	REMOTE MAINTENANCE	800-7
800.3	REMOTE SYSTEM MONITOR	800-12
APPENDIX A	CUSTOMER DATABASE PROGRAMMING	A-1
APPENDIX B	STARPLUS 96EX PART NUMBERS	B-1
APPENDIX C	AEC The Messenger™ 212 Plus	C-1

LIST OF FIGURES

SECTION 100	INTRODUCTION	
SECTION 200	FEATURE DESCRIPTION	
	Figure 200-1 SP 96EX Default Mapping	200-11
SECTION 300	FEATURE OPERATION	
	Figure 300-1 Starplus 96EX Executive Key Telephone	300-2
SECTION 400	GENERAL DESCRIPTION	
	Figure 400-1 Starplus 96EX System Block Diagram	400-2
	Figure 400-2 STARPLUS® Station Instruments	400-5
SECTION 500	INSTALLATION	
	Figure 500-1 Mounting Arrangements	500-2
	Figure 500-2 Mounting Dimensions	500-3
	Figure 500-3 Basic KSU and Expansion KSU	500-4
	Figure 500-4 Ext. Power Housing2 (EPS2) & Power Supply	500-6
	Figure 500-5 Tone Emitter on BC Card	500-7
	Figure 500-6 Typical Battery Interconnection Layout	500-8
	Figure 500-7 DC/DC Converter Unit (DC/DC)	500-9
	Figure 500-8 Central Processing Board (CPB)	500-10
	Figure 500-9 Central Office Interface Board (COB)	500-12
	Figure 500-10 Amplified CO Interface Board (COA)	500-14
	Figure 500-11 Key Station Interface Board (KIB)	500-15
	Figure 500-12 Power Failure Transfer Circuit (PFT)	500-18
	Figure 500-13 Station Modular Block Wiring	500-20
	Figure 500-14 SP 96EX Key Telephone Wall Mounting	500-22
	Figure 500-15 Application Board (APL)	500-24
	Figure 500-16 Application Board Connections	500-25
	Figure 500-17 Application Board Modular Connections	500-26
	Figure 500-18 CO and SLT RAN Connections	500-27
	Figure 500-19 RSM Baud Rate Selection	500-29
	Figure 500-20 RS-232C Connections	500-30
	Figure 500-21 Installing the Expansion KSU	500-32
SECTION 600	CUSTOMER DATA BASE PROGRAMMING	
	Figure 600-1 Data Terminal Program Codes Cross Reference	600-2
	Figure 600-2 SP 96EX Default Button Mapping	600-3
SECTION 610	SYSTEM PARAMETERS PROGRAMMING	
SECTION 620	CO LINE ATTRIBUTES PROGRAMMING	
SECTION 630	STATION ATTRIBUTES PROGRAMMING	
	Figure 630-1 DSS Console Maps 1-3 Button Assignment	630-6
	Figure 630-2 DSS Console Maps 4 & 5 Button Assignment	630-7

SECTION 640 EXCEPTION TABLES PROGRAMMING

SECTION 650 LEAST COST ROUTING PROGRAMMING

SECTION 660 SYSTEM DATA BASE PRINTOUTS

Figure 660-2 DB Printout of CO Line Attributes 660-11

Figure 660-3 DB Printout of Station Attributes 660-13

Figure 660-4 DB Printout of Exception Tables 660-15

Figure 660-5 DB Printout of System Speed Numbers 660-17

Figure 660-6 DB Printout of LCR Default 660-19

SECTION 700 SYSTEM CHECKOUT

SECTION 800 MAINTENANCE AND TROUBLESHOOTING

Figure 800-1 Remote Maintenance Help Menu 800-7

Figure 800-2 Starplus 96EX Configuration with/LCR 800-8

Figure 800-3 CO Line Configuration Printout 800-9

Figure 800-4 Station Configuration Printout 800-10

Figure 800-5 APL Configuration Printout 800-11

Figure 800-6 Event Trace as it appears on Display 800-14

APPENDIX A CUSTOMER DATABASE PROGRAMMING

APPENDIX B STARPLUS 96EX PART NUMBERS

APPENDIX C AEC The Messenger™ 212 Plus

Figure C-1 SLT to AEC Connections C-2

Figure C-2 ACT 8 Cond. to 6 Cond. RAN Line Cord C-3

Figure C-3 COB to AEC Connections C-4



A to Z KELLATRONICS, INC.

tel: 800.766.3425	fax: 800.720.1172
818.773.8888	818.773.8899
www.kellatronics.com	info@kellatronics.com

LIST OF TABLES

SECTION 100	INTRODUCTION	
SECTION 200	FEATURE DESCRIPTION	
	Table 200-1 Alphabetical Feature Index	200-2
SECTION 300	FEATURE OPERATION	
	Table 300-1 Starplus 96EX System Numbering Plan	300-3
	Table 300-2 Button Programming Codes	300-10
	Table 300-3 Entered Digits to Letters Conversion Chart	300-13
	Table 300-4 Entered Digits to Letters Conversion Chart	300-19
	Table 310-1 96EX LCD Displays	310-1
SECTION 400	GENERAL DESCRIPTION	
	Table 400-1 System Capacity	400-7
	Table 400-2 Electrical Specifications	400-8
	Table 400-3 Environmental Specifications	400-9
	Table 400-4 Loop Limits	400-9
	Table 400-5 Dialing Specifications	400-9
	Table 400-6 FCC Registration Numbers	400-9
	Table 400-7 Dimensions and Weight	400-10
	Table 400-8 Miscellaneous Specifications	400-10
	Table 400-9 Key Telephone Audible Signals	400-11
	Table 400-10 DSS/BLF Button Visual Indicators	400-12
	Table 400-11 CO Line Button Visual Indicators	400-12
	Table 400-12 Function Button Visual Indicators	400-13
	Table 400-13 Single Line Telephone Audible Signals	400-14
	Table 400-14 Ring Gen./Message Wait (RG) Specifications	400-14
	Table 400-15 OPX Telephone Audible Signals	400-15
	Table 400-16 Mean Time Between Failures (MTBF)	400-16
SECTION 500	INSTALLATION	
	Table 500-1 Battery Back Up Duration	500-7
	Table 500-2 Battery Recharge Time	500-7
	Table 500-3 P-1 Connecting Block	500-13
	Table 500-4 P-2 Connecting Block	500-13
	Table 500-5 Station Connecting Block (KIB)	500-16
	Table 500-6 Power Failure Transfer Unit Connections(PFT)	500-17
	Table 500-7 Station Connecting Block (SLT)	500-17
	Table 500-8 OPX Station Connecting Block (OPX)	500-21
	Table 500-9 SMDR Printout	500-31
SECTION 600	CUSTOMER DATA BASE PROGRAMMING	
	Table 600-1 Default Values	600-4
SECTION 610	SYSTEM PARAMETERS PROGRAMMING	
	Table 610-1 Hook Switch Activity	610-18
SECTION 620	CO LINE ATTRIBUTES PROGRAMMING	
	Table 620-1 Class of Service (COS)	620-5

SECTION 630	STATION ATTRIBUTES PROGRAMMING	
	Table 630-1 Flexible Button Display Designations	630-12
SECTION 640	EXCEPTION TABLES PROGRAMMING	
	Table 640-1 Class of Service (COS)	640-1
	Table 640-2 Allow/Deny Toll Table	640-2
SECTION 650	LEAST COST ROUTING PROGRAMMING	
	Table 650-1 LCR Class of Service Table	650-5
	Table 650-2 Daily Start Time & Weekly Schedule Tables	650-7
	Table 650-3 Examples: Daily & Wkly Start Time Tables	650-8
SECTION 660	SYSTEM DATA BASE PRINTOUTS	
SECTION 700	SYSTEM CHECKOUT	
SECTION 800	MAINTENANCE AND TROUBLESHOOTING	
	Table 800-1 Central Processing Board (CPB)	800-1
	Table 800-2 DC/DC Converter Unit (DC/DC)	800-2
	Table 800-3 Battery Charging Board (BC)	800-2
	Table 800-4 Key Station Interface Board (KIB)	800-3
	Table 800-5 Central Office Interface Board (COB)	800-3
	Table 800-6 Single Line Interface Board (SIB)	800-4
	Table 800-7 SLT Ring Generator (RG) and M/W Power Supply	800-4
	Table 800-8 Application Board (APL)	800-4
	Table 800-9 Single Line Receiver/Sender Unit (SLU)	800-5
	Table 800-10 RS-232C Module (RSM)	800-5
	Table 800-11 Power Failure Transfer Unit (PFT)	800-5
	Table 800-12 Amplified Conference Board (COA)	800-6
	Table 800-13 Off-Premise Extension Board (OPX)	800-6
APPENDIX A	CUSTOMER DATABASE PROGRAMMING	
	Appendix A-1 System Parameters	A-1
	Appendix A-2 UCD and Hunt Group Parameters	A-3
	Appendix A-3 Voice Mail Group Parameters	A-4
	Appendix A-4 CO Line Programming (Flash 40)	A-5
	Appendix A-5 CO Line Ringing Assignment Chart	A-7
	Appendix A-6 Station Programming (Flash 50)	A-8
	Appendix A-7 Button Assignment Chart (Flash 50)	A-9
	Appendix A-8 System Speed Dial Numbers	A-11
	Appendix A-9 Exception Tables (Flash 60)	A-13
	Appendix A-10 Least Cost Routing (Flash 61)	A-15
	Appendix A-11 Route List Table	A-16
	Appendix A-12 Insert/Delete Tables	A-20
	Appendix A-13 3-Digit Route List Table	A-22
	Appendix A-14 6-Digit Office Code Table	A-23
APPENDIX B	STARPLUS 96EX PART NUMBERS	
	Appendix B-1 Starplus 96EX Component List	B-1
APPENDIX C	AEC The Messenger™ 212 Plus	

STARPLUS® 96EX ISSUE CONTROL SHEET

ISSUE	DATE	CHANGE
1	June 1991 March 1992	First Draft Miscellaneous Update to manual. Techfact Notice #025 Issued 3/2/92 with corrected pages.

SECTION 100

INTRODUCTION

100.1 PURPOSE

This manual provides the information necessary to program, install, operate and maintain the Starplus 96EX Hybrid Key Telephone System.

100.2 REGULATORY INFORMATION (USA)

The Federal Communications Commission (FCC) has established rules which allow the direct connection of the Starplus 96EX Key Telephone System to the telephone network. Certain actions must be undertaken or understood before the connection of customer provided equipment is completed.

A. Telephone Company Notification

Before connecting the Starplus 96EX Hybrid Key Telephone System to the telephone network, the local serving telephone company must be given advance notice of intention to use customer provided equipment and provided with the following information:

- The telephone numbers to be connected to the system.
- The FCC Registration Number located on the Key Service Unit (KSU):
DLP82V-17568-MF-E
- If no Key Telephones are programmed to have a pooled group button, use the following FCC Registration Number:
DLP82V-17567-KF-E
- The Ringer Equivalence Number also located on the KSU: 0.5B
- The Universal System Ordering Code (USOC) jack required for direct interconnection with the telephone network: RJ21X

B. Incidence of Harm

If the telephone company determines that the customer provided equipment is faulty and possibly causing harm or interruption to the telephone network, it should be disconnected until repairs can be made. If this is not done, the telephone company may temporarily disconnect service.

C. Changes in Service

The local telephone company may make changes in its communications facilities or procedures. If these changes should affect the use of the Starplus 96EX or compatibility with the

network, the telephone company must give written notice to the user to allow uninterrupted service.

D. Maintenance Limitations

Maintenance on the 96EX Hybrid Key Telephone System is to be performed only by the manufacturer or its authorized agent. The user may not make any changes and/or repairs except as specifically noted in this manual. If unauthorized alterations or repairs are made, any remaining warranty may be voided.

E. Notice of Compliance

The 96EX Hybrid Key Telephone System complies with rules regarding radiation and radio frequency emissions by Class A computing devices. In accordance with FCC Standard 15 (Subpart J), the following information must be supplied to the end user:

CAUTION

"This equipment generates and uses RF energy and if not installed and used in accordance with the Instruction Manual, may cause interference to Radio Communications. It has been tested and found to comply with the limits for a Class A computing device, pursuant to Subpart J of Part 15 of the FCC Rules, which are designed to provide reasonable protection against such interference, when operated in a commercial environment. Operation of this equipment in a residential area is likely to cause interference, in which case the user, at his own expense, will be required to take whatever measures may be required to correct the interference."

F. Hearing Aid Compatibility

All Starplus 96EX Key Telephones are Hearing Aid Compatible, as defined in Section 68.316 of Part 68 FCC Rules and Regulations

G. OPX Circuit

The Starplus 96EX Key Telephone System may be equipped with single line OPX boards which provide four (4) 48 volt FCC registered 2500- type single line interface ports.

- Each OPX port when used to support an off-premise extension requires an OL13C network circuit.
- An FCC registered interface such as a RJ21X is also required to connect to the public network.

100.3 REGULATORY INFORMATION (CANADIAN)

- Department of Communications (DOC)
Certification Number: 676 2799A
- Load Number: 19
- Standard Connector: CA21A
- Canadian Standards Association (CSA)
File Number: LR57228

A. Notice

The Canadian Department of Communications' label identifies certified equipment. This certification means that the equipment meets certain telecommunications network protective, operational and safety requirements. This Department does not guarantee the equipment will operate to the user's satisfaction.

Before installing this equipment, users should ensure that it is permissible to be connected to the facilities of the local telecommunications company. The equipment must also be installed using an acceptable method of connection. In some cases, the company's inside wiring associated with single line individual service may be extended by means of a certified connector assembly (telephone extension cord). The customer should be aware that compliance with the above condition may not prevent degradation of service in some situations.

Repairs to certified equipment should be made by an authorized Canadian maintenance facility designated by the supplier. Any repairs or alterations made by the user to this equipment, or equipment malfunctions, may give the telecommunications company cause to request the user to disconnect the equipment.

Users should ensure for their own protection that the electrical ground connections of the power utility, telephone lines and internal metallic water pipe system, if present, are connected together. This precaution may be particularly important in rural areas.

CAUTION

Users should not attempt to make such connections themselves, but should contact the appropriate electric inspection authority, or electrician, as appropriate.

B. Explanation of Load Number

The Load Number (LN) assigned to each terminal device denotes the percentage of the total load to be connected to a telephone loop which is used by the device to prevent overloading. The termination on a loop may consist of any combination of devices subject only to the requirement that the total of the load numbers of all the devices does not exceed 100.

C. Maintenance Limitations

Maintenance on the Starplus 96EX Hybrid Key Telephone System is to be performed only by the manufacturer or its authorized agent. The user may not make any changes and/or repairs except as specifically noted in this manual. If unauthorized alterations or repairs are made, any remaining warranty may be voided.

D. Notice of Compliance

The Starplus 96EX Hybrid Key Telephone System complies with Class A or Class B limits of the Canadian Radio Interference Regulations. In accordance with FCC Standard 15 (Subpart J), the following information must be supplied to the end user:

CAUTION

"This equipment generates and uses RF energy and if not installed and used in accordance with the Instruction Manual, may cause interference to Radio Communications. It has been tested and found to comply with the limits for a Class A or Class B computing device, pursuant to Subpart J or Part 15 of the FCC Rules, which are designed to provide reasonable protection against such interference, when operated in a commercial environment. Operation of this equipment in a residential area is likely to cause interference, in which case the user, at his own expense, will be required to take whatever measures may be required to correct the interference."

E. OPX Circuit

The Starplus 96EX Key Telephone Systems may be equipped with single line OPX boards which provide four (4) 48 volt registered 2500-type single line interface ports.

- A DOC registered interface such as a CA21A is also required to connect to the public network.

100.4 UL/CSA SAFETY COMPLIANCE

The Starplus 96EX Hybrid Key Telephone System has met all safety requirements and was found to be in compliance with the United Laboratories (UL) 1459 Second Edition and Canadian Standards Association (CSA) CS-03 Standard. The Starplus 96EX is authorized to bear the UL and CSA marks.

E. OPX Circuit

The Starplus 96EX Key Telephone Systems may be equipped with single line OPX boards which provide four (4) 48 volt registered 2500-type single line interface ports.

- A DOC registered interface such as a CA21A is also required to connect to the public network.

100.4 UL/CSA SAFETY COMPLIANCE

The Starplus 96EX Hybrid Key Telephone System has met all safety requirements and was found to be in compliance with the United Laboratories (UL) 1459 Second Edition and Canadian Standards Association (CSA) CS-03 Standard. The Starplus 96EX is authorized to bear the UL and CSA marks.

SECTION 200

FEATURE DESCRIPTION

The features of the Starplus 96EX Hybrid Key Telephone System are listed and described below in alphabetical order. An abbreviated feature index is provided in Table 200-1.

SYSTEM AND STATION FEATURES

200.1 ACCOUNT CODES

An account code is the last field within Station Message Detail Recording (SMDR), that provides the ability to track specific calls by entering a non-verified, variable length (up to 12 digits) identifier. The use of forced Account Codes is optional, offered on a system wide basis.

200.2 AMPLIFIED CENTRAL OFFICE BOARD

The Amplified Central Office Board (COA) is an optional card that is installed in place of the standard COB. It enhances audio levels and is recommended for DISA and multi-line conference applications.

200.3 ATTENDANT RECALL

When a line has been left on hold for a programmable period of time, the station placing that line on hold will be recalled. If that station fails to answer the recall, the call will be recalled to the attendant(s) for handling. There can be three attendants per system. Transferred, Parked and Camp-on recalls will also recall the Attendant.

200.4 AUTOMATIC LINE ACCESS

Each station, key or SLT, may have their phone programmed to access a particular CO Line such as a private line or a line from a Group of CO lines upon going off-hook. This is useful in Centrex or PBX applications when station users have dedicated or individual lines. Outside line dial tone is received just by going off-hook, without the need to dial an access code.

200.5 AUTOMATIC NIGHT SERVICE

The system may optionally be programmed to go into and out-of night service automatically. This method does not require the attendant to activate or deactivate night service on a daily basis. The automatic night service is enabled and disabled on a programmable daily schedule including Saturday and Sunday schedules. A time can be set to enable Night Service and to Disable Night Service on a per day basis.

200.6 AUTOMATIC PAUSE INSERTION WITH SPEED DIAL

If a flash command is placed into system speed dial numbers, station speed dial numbers, save number redial or last number redial, a pause will automatically be inserted after the flash. A pause will also be automatically inserted after a PBX dialing code has been used.

200.7 AUTOMATIC PRIVACY

Privacy is automatically provided on all calls. If one station is conversing, another station cannot intrude on that line. The Automatic Privacy feature can be disabled, allowing another station to join in on existing CO line conversations.

200.8 AUTOMATIC SELECTION

The user can select an outside line, intercom station, speed dial button, or dial a feature and automatically place the phone in the dialing mode without pressing the ON/OFF button or lifting the handset.

200.9 BACKGROUND MUSIC

Each key telephone user may receive music over their speaker when an optional music source is connected to the system. This feature can be allowed or denied on a system-wide basis by programming.

200.10 BASIC KEYSSET COMPATIBILITY

The Starplus Basic Electronic Telephone will operate on the Starplus 96EX Hybrid Key Telephone System. The Starplus Basic keyset is a fully modular instrument with 8 fixed feature/function buttons and 6 buttons that can be flexibly assigned as CO/PBX/Centrex lines, Station DSS, or feature/function buttons. This telephone features on-hook dialing and Call Announce, Intercom, two (2) Volume Controls, a Personal Directory, and a 12 key "DTMF" dial pad.

NOTE: Full speakerphone operation or Call Announce with handsfree reply on intercom are not provided with the Basic Key Telephone.

200.11 BATTERY BACK-UP (MEMORY)

A long-life lithium battery is located on the Central Processing Board (CPB) to protect system memory in case of commercial power outage or the system power being turned off for a period of time. Battery Back-up Memory retains all system features includ-

Table 200-1 Alphabetical Feature Index

FEATURE	AVAILABLE	INTERNAL EQUIPMENT REQUIRED	EXTERNAL EQUIPMENT REQUIRED
Account Code	S	N	Printer
Account Code (Single Line)	S	N	Printer
Attendant Disable Outgoing Access	S	N	N
Amplified Central Office (COA)	O	COA	N
Attendant Overflow	S	N	N
Attendant Override	S	N	N
Attendant Recall	S	N	N
Automatic Line Access	S	N	N
Automatic Night Service	S	N	N
Automatic Pause Insertion w/Speed Dial	S	N	N
Automatic Privacy	S	N	N
Automatic Selection	S	N	N
Background Music	S	N	Music Source
Basic Key Set Compatability	S	N	Basic Key Telephone
Battery Backup (Memory)	S	N	N
Battery Backup (System)	O	BC	Battery Pkg
Busy Lamp Field (BLF)	S	N	N
Call Announce Privacy	S	N	N
Call Back	S	N	N
Call Forward: Station			
Call Forward - All Calls	S	N	N
Call Forward - Busy	S	N	N
Call Forward - No Answer	S	N	N
Call Forward - Busy/No Answer	S	N	N
Forward to Pilot (UCD, VM, Hunt)	S	N	N
Station Off-Net Forward (via speed dial)	S	APL	N
Call Forward: Preset			
Call Forward Preset to Stations	S	N	N
Call Forward Preset to Hunt Groups	S	N	N
Call Forward Preset to Off-Net (via speed dial)	S	N	N
Call Forward Preset to UCD Groups	S	N	N
Call Forward Preset to Voice Mail Groups	S	APL	Voice Mail System
Call Forward: CO Lines			
Incoming CO Lines Off-Net (via speed dial)	S	APL	N
Calling Station Tone Mode Option	S	N	N
Call Park	S	N	N
Call Pick-up:			
Group Pick-up	S	N	N
Directed Call Pick-up	S	N	N
Call Transfer	S	N	N
Camp-On	S	N	N
Camp-On Recall	S	N	N

S = Standard Feature; O=Optional: Requires additional hardware; N=No additional hardware required

Table 200-1 Alphabetical Feature Index (Cont'd)

FEATURE	AVAILABLE	INTERNAL EQUIPMENT REQUIRED	EXTERNAL EQUIPMENT REQUIRED
Canned Toll Restriction	S	N	N
Centrex Compatability	S	N	N
Centrex/PBX Transfer	S	N	N
Chaining Speed Bins	S	N	N
CO Line Access	S	N	N
CO Line Class of Service	S	N	N
CO Line Control (contact)	S	PFT	N
CO Line Groups	S	N	N
CO Line Loop Supervision	S	N	N
CO Line Queue	S	N	N
CO Line Incoming Ring Assignment:			
Assigned Per CO Line	S	N	N
CO Ring Detect	S	N	N
Conference:			
Add-on	S	N	N
Multi-Line	S	N	N
Unsupervised Trunk-to-Trunk	O	APL	N
SLT - Add-on	S	N	N
SLT - Multi-Line	S	N	N
SLT - Conference with Personal Park	S	N	N
Conference Enable/Disable Per Station	S	N	N
Conference Enable/Disable Per CO Line	S	N	N
Data Base Printout (dump)			
Day/Night Class of Service (COS)	S	N	N
Default Button Mapping			
Dial Pulse Sending	S	N	N
Dialing Privileges	S	N	N
Direct CO Line Ringing:			
To Stations	S	N	N
To UCD Groups	S	N	N
To Hunt Groups	S	APL	N
To Off-Net (via speed dial)	S	APL	N
To Voice Mail Groups	S	N	Voice Mail System
Direct Station Selection	S	N	N
Directed Call Pick-up:			
Pick-up from Stations	S	N	N
Pick-up from UCD Groups	S	N	N
Direct Inward Station Access (DISA):			
Programmable Access	S	N	N
CO Line Group Access	S	N	N
Station Access	S	N	N

S = Standard Feature; O=Optional: Requires additional hardware; N=No additional hardware required

Table 200-1 Alphabetical Feature Index (Cont'd)

FEATURE	AVAILABLE	INTERNAL EQUIPMENT REQUIRED	EXTERNAL EQUIPMENT REQUIRED
Do Not Disturb (DND)	S	N	N
One-Time Do Not Disturb	S	N	N
DTMF Sending	S	N	N
Emergency Transfer	O	PFT	SLT's
End to End Signalling			
Exclusive Hold	S	N	N
Executive Override	S	N	N
Executive/Secretary Transfer	S	N	N
External Night Ringing	S	N	N
Flash		S	NN
Flash on Intercom	S	N	N
Flash with Speed Dial	S	N	N
Flexible Attendant(s)	S	N	N
Flexible Button Assignment	S	N	(22 buttons)
Forced Account Codes	S	N	N
Group Call Pick-up	S	N	N
Headset Compatability	S	N	N
Headset Mode	S	N	N
Hearing Aid Compatible	S	N	N
Hold Preference	S	N	N
Hold Recall	S	N	N
Hot Line/Ring Down	S	N	Key Station
Hunt Groups: (8 x 8)			
Pilot Hunting	S	N	N
Station Hunting	S	N	N
Hunt Group Chaining	S	N	N
Intercom Calling	S	N	N
Intercom Signaling Select	S	N	N
Last Number Redial (LNR)	S	N	N
LCD Interactive Display	S	N	Exec Telephone
Least Cost Routing (LCR):			
LCR 3 Digit Tables	S	N	N
LCR 6 Digit Tables	S	N	N
Route List Tables	S	N	N
Insert/Delete Tables	S	N	N
Weekly Time Tables	S	N	N
Daily Start Time Tables	S	N	N
Exception Tables	S	N	N
Default LCR Database	S	N	N
LCR Routing for Toll Information	S	N	N
Loop Button CO Line Access	S	N	N
Loud Bell Control (LBC)	O	PFT	Gen & Bells

S = Standard Feature; O=Optional: Requires additional hardware; N=No additional hardware required

Table 200-1 Alphabetical Feature Index (Cont'd)

FEATURE	AVAILABLE	INTERNAL EQUIPMENT REQUIRED	EXTERNAL EQUIPMENT REQUIRED
Meet Me Page	S	N	N
Message Waiting	S	N	N
Message Waiting Reminder Tone	S	N	N
Music On Hold	S	N	Music Source
Mute Key	S	N	N
Name in Display	S	N	Exec Telephone
Night Service:			
Manual Operation	S	N	N
Automatic Operation	S	N	N
Weekly Night Mode Schedule	S	N	N
Night Class of Service (COS)	S	N	N
Universal Night Answer (UNA)	S	N	N
Night Ringing Assignment	S	N	N
External Night Ringing	S	N	N
Off-Hook Preference	S	N	N
Auto Line Access	S	N	N
Auto Feature Access	S	N	Keyset
Hot Line/Ring down	S	N	Keyset
Intercom Access	S	N	Keyset
User Programmable Preference	S	N	Keyset
Off-Hook Signalling	S	N	N
Off-Premise Extensions (OPX)	O	OPX/APL/RG	OPX Circuit
On Hook Dialing	S	N	N
On-Line Programming	S	N	N
Paging			
External	O	APL	Paging Equip
Internal	S	N	N
Paging Access Restriction	S	N	N
Pause Timer	S	N	N
PBX Dialing Codes	S	N	N
Personalized Messages	S	N	N
Personalized Message Code on a Flex Key	S	N	N
Phone Box	S	N	Phone Box
Pool Button Operation	S	N	N
Preferred Line Answer	S	N	N
Privacy Release:			
Per Station Option	S	N	N
Per CO Line Option	S	N	N
Private Line	S	N	N
Pulse-To-Tone Switchover	S	N	N
Range Programming	S	N	N
Remote Administration (Database)	S	N	N

S = Standard Feature; O=Optional: Requires additional hardware; N=No additional hardware required

Table 200-1 Alphabetical Feature Index (Cont'd)

FEATURE	AVAILABLE	INTERNAL EQUIPMENT REQUIRED	EXTERNAL EQUIPMENT REQUIRED
Remote System Monitor and Maintenance	S	N	Optional Modem
Save Number Redial (SNR)	S	N	N
Single Line Telephone (SLT) Compatability	O	SLT/APL/RG	2500 Type SLT
SLT Personal Park:			
SLT Personal Park Transfer	S	N	N
SLT Conference with Personal Park	S	N	N
SLT "Flip-Flop" Hold	S	N	N
Station Message Detailed Recording (SMDR)	S	RSM	Printer
Speakerphone	S	N	N
Station Class of Service	S	N	N
Station Speed Dial	S	N	N
System Capacity:			
up to 24x48 Configuration	S	N	N
up to 40x96 Configuration	O	Expansion KSU	N
System Hold	S	N	N
System Speed Dial	S	N	N
Toll Restriction (Table Driven)			
Transfer Recall	S	N	N
Uniform Call Distribution (UCD): (8 x 8)			
Alternate UCD Group Assignments	S	N	N
Overflow Station Assignment	S	N	N
Incoming CO Direct Ringing	S	N	N
Recorded Announcements (RAN)	O	N	RAN Device
Two Recorded Announcements for Transferred CO Calls	O	N	RAN Device
Number of Calls in Queue Display	S	N	N
UCD Auto Wrap-up with Timer	S	N	N
Available/Unavailable Mode			
Universal Night Answer (UNA)	S	N	N
Voice Mail Groups: VM (8 x 8)		SIB/APL/RG	Voice Mail System
In Band Signaling Integration	O	APL	N
Voice Mail Message Waiting Indication	S	N	N
Voice Mail CO Disconnect Signal Pass thru	S	APL	N
Voice Mail Tone Mode Calling Option	S	N	N
Volume Control	S	S	N

S = Standard Feature; O=Optional: Requires additional hardware; N=No additional hardware required

ing both system and station speed dial during a power outage.

200.12 BATTERY BACK-UP (SYSTEM)

When the optional Battery Charging Card and maintenance free (gel-type) batteries are installed, full system power can be maintained in the event of commercial power outage. Calls in progress when power fails will continue without interruption. The batteries are recharged when the system returns to normal AC operation.

200.13 BUSY LAMP FIELD (BLF)

When a button on a Key Telephone is assigned as a DSS it also serves as a Busy Lamp Field to display the status of that telephone.

200.14 CALL ANNOUNCE - PRIVACY

Each telephone user can set their intercom signaling switch to receive intercom call announcements without having the calling party hear any conversations in progress.

200.15 CALL BACK

A station can initiate a call back request to another busy station. As soon as that station becomes idle, the station that left the call back request is signaled.

200.16 CALL FORWARD: STATION

A. Call Forward - All Calls

This feature allows a station the ability to have all their calls (internal or external) forwarded immediately to a designated station, a UCD group pilot number, Voice Mail group number, or Hunt group. (See Note)

B. Call Forward - Busy

This feature allows a station the ability to have their calls forwarded to a designated station, a UCD group pilot number, Voice Mail group number, or Hunt group when their station is busy. (See Note)

C. Call Forward - No Answer

This feature allows a station the ability to have their calls forwarded to a designated station, a UCD group pilot number, Voice Mail group number or Hunt group number when there is no answer at the station. No answer calls forward when the system-wide "no answer timer" expires. (See Note)

D. Call Forward - Busy/No Answer

Allows a stations the ability to forward a combination busy/no answer calls to a designated station, a UCD group pilot number, Voice Mail group number, or Hunt group. No answer calls

forward when the system-wide "no answer timer" expires. Initial CO ringing, transferred CO ringing and intercom ringing calls can all be forwarded. Calls that ring to an idle station will be call forwarded after expiration of the No Answer ring timer. (See Note)

E. Call Forward - Off-Net

Stations will be allowed to forward intercom and transferred CO line calls to an off-net location. This allows a station to reroute calls that would normally be lost. Calls can be forwarded to home or another off-net site. Initially ringing CO calls cannot be forwarded with this feature (see Incoming CO lines Off-Net Forward, feature). (See Note)

NOTE: Initial Ringing Incoming: calls will forward to groups, (ie: UCD, Voice Mail, Hunt) if the station forwarded is the only station assigned to ring on the CO line.

200.17 CALL FORWARD: PRESET

This feature allows the system data base to be configured so that incoming CO Lines, which are programmed to ring at a particular station, can be forwarded elsewhere in the system predetermined by programming. This feature is active if the station ringing is not answered in a specified time. This is particularly useful in "overflow" applications where a Voice Mail or Auto Attendant may be in use.

A station may have one designated preset forward location defined in the data base.

Preset Call Forward is chainable only to other predetermined preset forward stations specified in the database up to a chain of 5 stations.

Chainable Preset Call Forwarding will force the incoming CO Line to ring at each station preassigned in the database for the Preset Forward Ring Timer specified in the database before forwarding.

Each station in the system may, independently, have incoming CO calls preset forwarded to the following destinations:

A. Preset Call Forward - Stations

Each Key Telephone user may have preset in the database Initial Ringing Incoming to be directed to another station in the system, if the call goes unanswered for a predetermined amount of time.

B. Preset Call Forward - Hunt Groups

CO Lines can be preset forwarded to ring into a Hunt Group from any station. A CO line will not preset forward to a busy Hunt group, however each time the preset forward timer expires (for a total of five attempts) the group will be

checked for an idle station. If a member of the group is idle the call will then be presented to that member.

C. Preset Call Forward - UCD Groups

CO Lines can be preset forwarded to ring into a UCD Group from any station. A CO line will not preset forward to a busy UCD group, however each time the preset forward timer expires (for a total of five attempts) the group will be checked for an idle station. If a member of the group is idle the call will then be presented to that member.

D. Preset Call Forward - VM Groups

CO Lines can be preset forwarded to ring into a Voice Mail Group from any station. A CO line will not preset forward to a busy Voice Mail group, however each time the preset forward timer expires (for a total of five attempts) the group will be checked for an idle Voice Mail port. If a VM port is idle the call will then be presented to Voice Mail.

E. Preset Call Forward - Off-Net

CO Lines can be preset forwarded to ring Off-Net via speed dial from any station. After the expiration of the preset forward timer, the system will select an idle CO line and dial the off-net location, then connect the two CO lines.

200.18 CALLING STATION TONE MODE OPTION

This feature will provide an easy means for a Calling station to override a desired stations H (handsfree) or P (call announce) intercom switch setting. A dial code has been added that is dialed in front of the extension number to force the tone ringing.

200.19 CALL PARK

An outside line can be placed into one of six parking locations and can be retrieved by any station that has a direct line appearance or an available loop button. Parked calls have their own recall timer and will recall the originating station and if still unanswered, the attendant(s).

200.20 CALL PICK-UP:

A. Group Pick-up

Stations can be placed in one or more of four pick-up groups. Stations within a group can pick up tone ringing intercom calls, recalling outside line ringing, or transferred outside line calls for another station in that group.

B. Directed Call Pick-up

A station can pick up an intercom call, transferred, incoming, or recalling outside line call to a specific unattended station. The call must be a tone ringing call.

200.21 CALL TRANSFER

An outside CO line can be transferred from one keyset to another. By using the TRANS button, screened (announced) or unscreened transfers can be made. The line being transferred rings on the keyset and provides Exclusive Hold flashing indication to the receiving party's keyset. Any number of attempts can be made to locate someone by calling different keysets without losing the call. If a line is transferred to a busy station, it will receive muted ringing.

200.22 CAMP-ON

A station may alert a busy party that an outside line is on hold and waiting for them by using the CAMP-ON button. To camp on a call, press the TRANS button to transfer the call to the desired busy station, then press the CAMP ON button. The busy party will receive a muted ring over the keyset speaker, and a visual flashing CAMP ON LED. By pressing the CAMP ON button, the person called places his existing outside call on hold and is connected to the person placing the Camp On. He can then pick up the call on the appropriate line. Calls cannot be camped on when a station is in DND or in Conference.

200.23 CAMP-ON RECALL

When a station does not answer a Camp On, that call will recall the person placing the Camp On, and if unanswered by them, will recall the attendant(s).

200.24 CANNED TOLL RESTRICTION

The system provides an easy means of applying the most common form of toll restriction where 1+ and 0+ along with 976, 555, and 411 type of calls are restricted with all local calls and 1-800, 911, 1-911, and 1-611 type of calls are allowed. This canned toll restriction is applied through the use of a single pre-built Class-of-Service and can be assigned to stations using range programming.

200.25 CENTREX COMPATIBILITY

The Starplus 96EX system provides features that are Centrex compatible so that Centrex users can utilize the 96EX to enhance their Centrex capabilities. The 96EX actually simplifies and provides easier access to many Centrex features by offering the following features;

A. Flex Button Programming

Flexible button programming allows Centrex users to program complex Centrex dial codes onto a key set button for easy one touch access to Centrex features.

B. Off-hook Preference

Both Key stations and Single line telephones may be programmed to have their personal Centrex line accessed automatically just by lifting the handset or pressing the ON/ OFF button. Internal features to the 96EX are still made available to key stations by accessing intercom before going off-hook.

C. Private Line appearance

The 96EX allows for private line assignment on an unlimited bases. Each station may have sole access to a particular outside line if desired and may also be assigned to receive incoming ringing on that line.

D. Programmable Flash Timer

CO line flash is a momentary opening on a CO line used for signaling. When using the 96EX in a Centrex environment the CO line flash is to signal the intention to transfer a caller using Centrex transfer. The CO line flash timer is programmable on a per CO line bases to facilitate a mixture of Centrex and CO lines within the same system.

E. Programming *, #, and Hook-Flashes into Speed Dial

Many Centrex codes utilize a hook-flash followed by in many cases the digit [*] and or [#]. The Starplus 96EX allows these codes to be programmed as a part of system or station speed dial sequences.

200.26 CENTREX/PBX TRANSFER

When Centrex or PBX lines are connected to the 96EX system, users may, by using the Flash button, transfer callers to other Centrex or PBX extensions. Additionally, the Flash command may be included within a Speed Bin and programmed onto a flex button for one button transfer.

200.27 CHAINING SPEED BINS

Speed dial bins may be chained together by simply pressing one speed bin, then another and another as required.

This is helpful for accessing Long Distant carriers or banking services when Account Codes may be required.

200.28 CO LINE ACCESS

Through programming, telephones are allowed or denied access to particular outside lines or line groups.

200.29 CO LINE CLASS OF SERVICE

Each CO Line may be programmed with a Class-of-Service to provide dialing privileges. The 96EX system uses a array between CO Line Class-of-Service and Station Class-Of-Service to offer a wide variety of dialing privilege possibilities. The CO Line Class-of-Service is also checked when a DISA caller selects an outside CO line to determine the dialing privilege for that call.

200.30 CO LINE CONTROL (CONTACT)

There are two control contacts (optional) which may be individually programmed as either CO Line Control (to control ancilliary equipment) or Loud Bell Control to control a customer provided ringing device to external areas. When programmed as CO Line Control and assigned to a CO line, the corresponding contact will close whenever that CO line is accessed by a station. (One PFT is required to provide one contact.)

200.31 CO LINE GROUPS

Outside lines can be placed in one of eight groups if the customer's business requires such grouping. Stations are then individually assigned access to these lines and given the ability to dial on particular lines.

200.32 CO LINE LOOP SUPERVISION

The 96EX system can be programmed to monitor CO lines while on-hold connected to RAN devices or Voice Mail systems or in Trunk-to-Trunk connections for disconnect signal provided by the Telco.

After a disconnect signal is detected, the 96EX system will release the CO lines and automatically place them back in service.

200.33 CO LINE QUEUE

When all the outside lines in a group are busy, stations can be placed in queue awaiting a line in the same group to become available. If a station doesn't answer the queue signal within 15 seconds, that station is dropped from the queue.

200.34 CO LINE INCOMING RINGING ASSIGNMENT

Each CO line may be programmed (in data base admin) so that incoming ringing on the specified CO line(s) may be assigned initial ringing to one of the following destinations:

- one or more stations (Keyset or SLT)

- To a UCD, Voice Mail or Hunt Group
- Off-Net (via Speed Dial)

The ring-in will follow Day Ring assignments unless Night Service mode is active, in which case all incoming CO calls will follow Night Ring assignments.

When ringing is assigned to a keyset, a direct line appearance or an idle Loop button must be available to receive the call. Station call forwarding of initial ringing CO call is possible and can be directed to other keysets with an available Loop button or direct appearance.

If the initially ringing CO call cannot ring at the destination assigned, it will ring at the first Attendant station.

NOTE: You cannot Station Call Forward an initially ringing CO call to UCD, Voice Mail, or Hunt groups if the line is assigned to ring at more than one station.

200.35 CO RING DETECT

The duration of the ringing signal from the CO or the PBX is matched with ringing detection circuitry in the KSU. The ring detect can range from 200 to 900 msec, programmed in 100 msec increments. This timer helps prevent false ringing.

200.36 CONFERENCE

There are three different types of conferencing:

A. Add On Conference

Up to five internal parties can engage in a conference, or four internal parties with a limit of one external party.

B. Multi-Line Conference

One internal station can engage in a conference with two outside parties.

C. Unsupervised Conference

The conference initiator can exit a conference with two outside parties and leave them in an unsupervised conference. The initiator can re-enter the conference at any time. The 96EX system can automatically terminate the call when both parties hang up, when Loop Supervision is provided by the telco and enabled in the data base.

A programmable conference timer will disconnect the unsupervised conference if the initiator does not re-enter. (Requires APL board.)

200.37 CONFERENCE ENABLE/DISABLE

A. Programmable Per Station:

This feature will allow the system to be administered on a per station basis for the ability of a station to initiate a conference.

B. Programmable Per CO Line:

CO lines can be individually programmed to allow Conference capabilities.

200.38 DATA BASE PRINTOUT (DUMP)

Through a system programming command, either portions of or a complete data base dump can be printed using the RS232C connector located on the 96EX CPB.

200.39 DAY/NIGHT CLASS OF SERVICE (COS)

This feature allows stations that are a certain COS during the day, to be assigned a different COS when the system is put in the night mode. The night COS goes into affect when the system is placed into the night mode, manually or automatically. This prevents the misuse of phones after hours.

200.40 DEFAULT BUTTON MAPPING

The 96EX allows for 22 flexible buttons on each Enhanced or Executive key telephones to be flexibly assigned to CO/PBX lines, DSS buttons, Speed Dial or Feature buttons. However the system will power up with a default button mapping as shown in Figure 200-1. The Basic key telephone buttons are defaulted exactly like the Enhanced and Executive with the exception of button 17 (button above the Hold button) which defaults as a loop button.

200.41 DIAL PULSE SENDING

Each CO interface circuit for outside lines can be programmed to send dial pulse or DTMF signals. Dialing speed and break/make ratios are programmable.

200.42 DIALING PRIVILEGES

The system provides a flexible means of providing toll or dialing restriction. Through the assignment of class of service (both station and outside line) many combinations of allow and deny numbers can be set. Both area and office codes can be screened for allow/deny privileges.

200.43 DIRECT INWARD SYSTEM ACCESS (DISA)

Allows as many as three simultaneous outside line calls to be programmed to provide direct access to the system and the use of features such as WATS lines, intercom dial tone or the ability to dial out on outgoing trunks without going through the attendant.

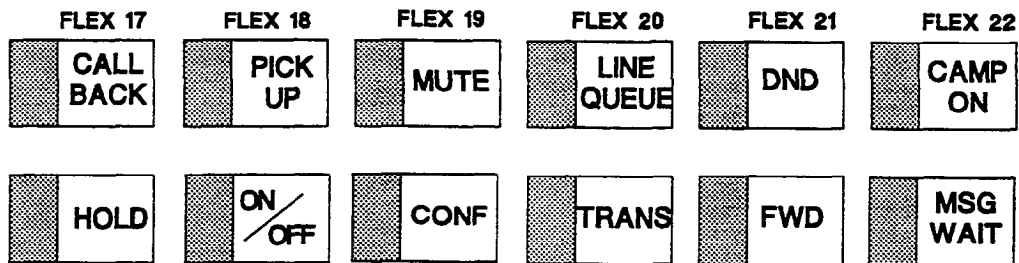
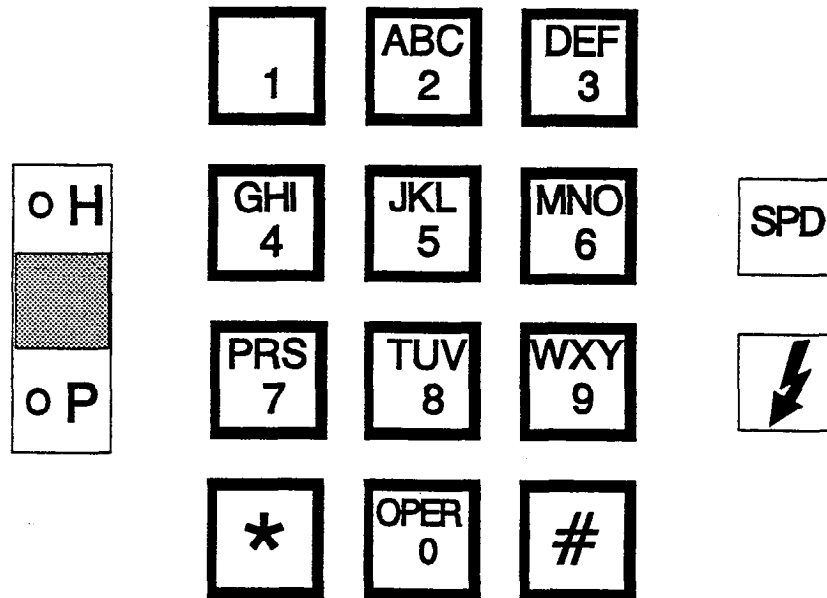
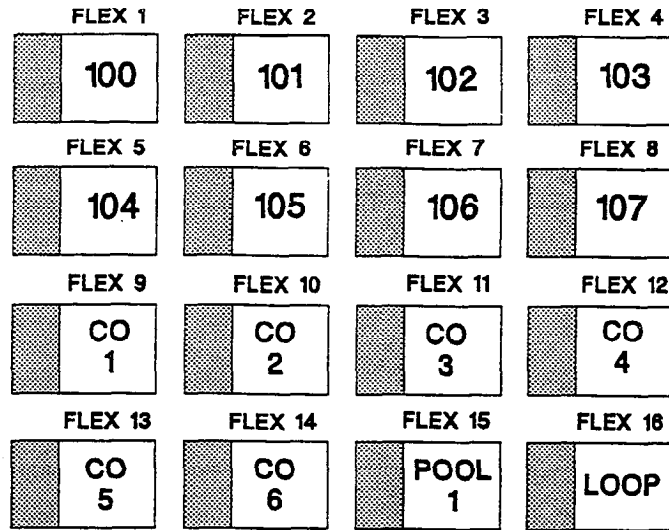

Figure 200-1 SP 96EX Default Mapping

The duration of a Trunk to Trunk DISA call can be set by the system administrator.

The APL card is required to provide the DISA feature.

A. Programmable Access

A 3-digit security code can be assigned in the system database to restrict unwanted use of the DISA circuits. Each DISA line can be programmed independently for 24 hour DISA use or night DISA use only.

B. CO Line Group Access

Incoming DISA callers may access all line groups such as FX or WATS lines or other outgoing services from home or while away from the office. The Class of Service assigned to the outgoing line accessed will determine the dialing privilege for the call.

C. Station Access

DISA callers may dial any station directly without going thru the attendant.

If a DISA caller attempts to call a station that is busy or does not answer the system will return ICM dial tone at the end of a programmable timer (Preset Forward Timer). This will allow the DISA caller to try another station without having to dial into the system again.

200.44 DIRECT STATION SELECTION

The user with DSS buttons assigned at their Key Telephone can call an intercom station by simply pressing the appropriate DSS button. The called station is automatically signaled.

200.45 DIRECTED CALL PICKUP

A. Call Pick-up - Station

A station can pick up an intercom call, transferred, incoming, or recalling outside line call to a specific unattended station. The call must be a tone ringing call.

B. Call Pick-up - UCD Groups

Stations outside of a UCD group can pick up an intercom call, transferred, incoming, or recalling outside line call ringing to a specific UCD station. The call must be a tone ringing call.

200.46 DISABLE OUTGOING CO LINE ACCESS

This feature allows the first Attendant station to dial a code and disable a CO line from outgoing CO calls. This applies to all station(s) that have access to that line. Incoming status is not affected. This feature is a part of the "Maintenance" package.

200.47 DO NOT DISTURB (DND)

Placing a keyset in DND will eliminate incoming outside line ringing, intercom calls, transfers and paging announcements. A ringing station may go into DND to silence ringing. The attendant can override a station in DND. The station in DND can use the telephone to make normal outgoing calls. A station can be denied this feature through programming.

A. One-Time Do Not Disturb

Allows a station user to turn off muted ringing that occurs while off hook (handset or ON/OFF) on another call. Useful when having an important conversation and do not wish to be disturbed by ringing. The station, while off hook, (ON/OFF or handset) depresses the DND button which eliminates muted ringing. When the station goes on-hook the DND button is extinguished and DND is canceled. This feature is not available to intercom Phone Box users.

200.48 DTMF SENDING

Each CO interface circuit for outside lines can be individually programmed to send DTMF (tone) or dial pulse signals.

200.49 EMERGENCY TRANSFER

Two Power Failure Transfer cards may be installed so that in case of a power failure, up to 12 CO lines can be automatically connected to specified customer provided SLT's.

200.50 END TO END SIGNALLING

This feature indicates the capability of the system to accept DTMF tones from stations, send them through the public network and have them received at the distant end for computer access, or a variety of control functions or inward call completion at a distant switching system.

200.51 EXCLUSIVE HOLD

When a line is placed on Exclusive Hold, no other station in the system can retrieve this call. Hold may be programmed to be activated on the first or second depression of the Hold button. CO Lines while in a transfer hold are always placed in an Exclusive Hold condition.

200.52 EXECUTIVE OVERRIDE

This feature allows certain stations to be designated as executive stations with the ability to override and "Barge in" on other keysets engaged in conversation on a CO line. Stations engaged in intercom conversations can be overridden, however, the intercom call will be dropped when the override occurs.

In addition to the station programmable option a system programmable option will enable or disable a warning tone when the station marked as an executive is cut into the conversation. This is useful for UCD agent supervisor or training personnel who require a service observing option.

NOTE: A decrease in volume may occur on the CO line after the barge-in occurs.

CAUTION: USE OF THIS FEATURE WHEN THE EXECUTIVE OVERRIDE WARNING TONE IS DISABLED MAY BE INTERPRETED AS A VIOLATION OF FEDERAL OR STATE LAWS, AND AN INVASION OF PRIVACY. CONSULT COUNSEL WITH RESPECT TO APPLICABLE LAW BEFORE INTRUDING ON CALLS USING THIS FEATURE.

200.53 EXECUTIVE/SECRETARY TRANSFER

There are four sets of Executive/ Secretary pairings available. When the Executive station is busy or in DND, the Secretary station will receive intercom calls and transfers. The Secretary station can signal the Executive in DND by using the Camp On feature.

200.54 EXTERNAL NIGHT RINGING

The system can be programmed so that CO lines marked for UNA will activate Loud Bell Control contact #1 connected to an external ringing device when the system is placed into Night mode. A PFT is required to provide one LBC contact.

200.55 FLASH

Provides telephone users with the ability to terminate an outside call or transfer a call behind a PBX or Centrex and restore dial tone without hanging up the handset. A FLASH button is located on each key telephone.

200.56 FLASH ON INTERCOM

This feature enables key station users to utilize the Flash Key to terminate pages and intercom calls. While connected to a page zone or another internal station pressing the Flash key will terminate the call and return intercom dial tone.

200.57 FLASH WITH SPEED DIAL

A flash can be programmed within a speed dial number. When this is done, a pause will automatically be inserted before the remaining speed dial digits are sent.

200.58 FLEXIBLE ATTENDANT

Any three Key Telephones in the system can be assigned as attendant stations. These stations will receive recalls and can place the system into Night Service. The attendant stations must be either Enhanced or Executive stations.

200.59 FLEXIBLE BUTTON ASSIGNMENT

Each Key Telephone has either 22 (Enhanced and Executive) or 6 (Basic Keypad) flexible buttons which can be individually programmed. One of the following seven operations can be selected for each button: Also refer to Sec. 300.22.

- Outside line. Automatically accesses assigned line. (Assigned in database)
- DSS/BLF. Automatically signal assigned station and provides BLF for off-hook and DND. (User programmable)
- Feature. Any feature with a dialing code (ie: Personalized Messages, Paging, Account Code, Call Park, Music, LCR, etc.) can be assigned to a flexible button. (User programmable)
- Group Access. (ie: UCD, Hunt, Voice Mail group pilot numbers) (User programmable)
- Speed dial. Automatically dials a Speed number. (System, Station, Saved Number Redial, Last Number Redial) (User programmable)
- Pooled group access. Some or all outside lines can be grouped; pressing this button accesses the highest numbered unused CO line in that group. (Assigned in database)
- Loop. Used to answer a transferred call on a line for which a user does not have a button assigned. (Assigned in database)

200.60 FORCED ACCOUNT CODES

The 96EX system allows the system to be arranged so that station users must enter an account code before placing an outside call. Account codes can also be used as a Traveling Class-of-Service to upgrade a restricted stations class-of-service for unrestricted dialing. Account codes must be entered before the call when forced.

200.61 FORCED LEAST COST ROUTING (LCR)

The 96EX System may be programmed on a per station basis to force the use of LCR for outgoing accessing. This allows the system administrator to maintain greater control over dialing patterns and the lines used for placing outgoing CO calls.

200.62 GROUP CALL PICK-UP

Stations can be placed in one or more of four pick-up groups. Stations within a group can pick up tone ringing intercom calls, recalling outside line ringing, or transferred outside line calls for another station in that group.

200.63 HEADSET COMPATIBILITY

The Starplus electronic key telephones are designed to allow the connection of an industry standard, electret mic compatible, modular headset. The user connects the modular headset to the handset jack on the telephone leaving the handset in place. The ON/OFF button on the key telephone is then used to activate the headset.

200.64 HEADSET MODE

Each Electronic key telephone can be individually programmed for headset operation. When programmed, an industry standard Headset with its adapter box may be connected to a key telephone for headset use. This allows handset or headset operation by switching the selector switch on the adapter box. Speakerphone operation and call announce on intercom are disabled while a station has enabled headset mode.

Once programmed in station programming the user may then select between headset mode or normal handset/speakerphone mode by simply dialing a code or pressing a user programmable flex button.

200.65 HEARING AID COMPATIBLE

All Starplus Electronic key telephones and Starplus Single Line Telephones are hearing aid compatible in compliance with the FCC Part 15, section 68.316. This allows the telephone to be used in conjunction with users wearing hearing aids.

200.66 HOLD PREFERENCE

This allows either Exclusive or System hold as the primary hold on the first depression of the HOLD button, depending on programming.

200.67 HOLD RECALL

When an outside call has been on Hold for a programmable length of time, recall ringing tone is sent to the station placing the call on Hold. If this station does not answer the recall, a recall tone is sent to the attendant(s).

200.68 HOT LINE

Electronic Key Telephones may be programmed to immediately call or ring down a particular station or outside number upon going off hook. This is performed by programming the stations Off-Hook preference to activate a DSS or Speed dial feature key.

200.69 HUNT GROUPS

The system can be arranged for up to eight (8) Hunt groups. Each Hunt group can contain up to eight stations each. Each Hunt group is independently arranged to utilize either a pilot hunting technique or station hunting technique.

A. Pilot Hunting

incoming CO, transferred CO, and intercom calls can be directed to a pilot extension number of a Hunt group. The system will search sequentially (in the order the extensions were entered in the data base programming) for an idle station in the group and will ring that station. Calls directed directly to stations (by calling the extension number) within the hunt group will not hunt but receive call progress tones of the extension dialed.

B. Station Hunting

Incoming CO, transferred CO, and intercom calls that are presented to a busy, or DND station, that is a member of a Station Hunt group, will search sequentially (in the order the extensions were entered in data base programming) for an idle station in the group and will ring that station. Calls can also be directed to the groups pilot number for hunting.

C. Hunt Group Chaining

Hunt Groups can be chained or joined together forming larger Hunt Groups. This is accomplished by assigning a pilot hunt group number as the last member of a group.

200.70 INCOMING CO LINES OFF-NET FORWARD (VIA SPEED DIAL)

Allows the first attendant to forward incoming CO calls to an off-net location. The attendant can forward a group of CO lines or all CO lines to a off-net location. The attendant must have a direct appearance of the CO line(s) to be forwarded. Off-net forwarding is accomplished via use of a speed dial bin and requires the APL card to be installed in the system.

200.71 INTERCOM CALLING

The System's architecture allows 14 intercom paths for internal traffic capability, 12 of these paths can be used by SLT's. A station is reached on intercom by dialing the associated three-digit number.

200.72 INTERCOM SIGNALING SELECT

Users can control the method by which they receive intercom calls and signals. A convenient intercom signal switch is located on each Key Telephone for easy selection. The choices are:

- Handsfree (H)(upper position). The station user, upon hearing a tone burst and voice announcement over the speaker, can reply handsfree. (Not available on Basic Electronic Telephone)
- Tone Ringing (T)(center position). A standard tone ring notifies the party of an incoming intercom call. The called party answers by lifting the handset or moving the switch to the handsfree (H) position or pressing the ON/OFF button.
- Privacy (P)(lower position). The station user receives a burst of tone and a voice announcement over his/her speaker. The microphone is deactivated for privacy. The called party must lift the handset or press the ON/OFF button to answer the call. (Or move the switch to the handsfree (H) position.)

200.73 LAST NUMBER REDIAL (LNR)

Permits the automatic redialing of the last telephone number dialed on an outside line. Up to 32 digits can be stored. Outside line selection of the same line used is automatic.

200.74 LCD INTERACTIVE DISPLAY

The optional 30 button Executive Key Telephone provides the user with visual indication of call status, Calls to and from other extensions, number dialed, line used and camp-on are some of the features displayed.

200.75 LEAST COST ROUTING (LCR)

Allows the system to automatically select the least costly route available according to the number dialed, the time of day/day of week, the class of service (COS) assigned to the station/trunk group priority level assigned.

A. LCR 3-Digit Table

This table is divided into 2 sections: "Leading 1" ("1" is dialed before the number) and "Non Leading 1" (no "1" is dialed before the number). This gives the system the ability to handle call routing in areas that require a "1" before a long distance number as well as in areas that do not require the "1".

B. LCR 6-Digit Table (Office Codes)

The 6-Digit Table can include 20 office code maps. Each map can be programmed to route up to 800 office codes to one of the 16 possible route lists. Each map must be associated with a specific area code in the 3-Digit Table. Several different office code maps can be used with the same area code to provide additional routing flexibility.

C. Route List Tables

Up to 16 different routes can be programmed. Each route can contain up to 4 route lists - one for each of the 4 time periods. Up to 7 CO line groups (routing choices) and their corresponding Insert/Delete Tables may be programmed within each route list.

D. Insert/Delete Tables

There are 20 Insert/Delete Tables. Up to 20 digits, including pauses, can be inserted and up to 16 digits deleted. Digits can be inserted before or after the number dialed, but can be deleted only from the beginning of a number dialed.

E. Weekly Time Tables

The least costly route for a particular dialed number may be different at different times of the day and on different days of the week. To accommodate this situation, there are 2 Time-of-Day tables - Daily Start Time Table and Weekly Schedule Table.

The Weekly Time table determines which one of the 4 Routes LCR should use based on the Time-of-Day and Day-of-the-Week.

F. Daily Start Time Tables

The Daily Start Time tables allow the user to match the Time Periods discount structure to the carriers rate schedule.

G. Exception Tables

This table is used to route operator assisted calls and any other calls which would use a 1- or 2-digit number rather than a 3-digit area code.

H. Default LCR Database

In an effort to decrease installation and set up time usually associated with LCR a default LCR data base has been incorporated. The default LCR data base will provide basic routing for all local and long distance dialing.

I. LCR Routing for Toll Information

This feature adds provisions to the LCR call processing which will allow common call routing for all toll information calls.

1-(XXX)555-1212, (XXX)555-1212, 1-555-1212 and 555-1212 calls will all be intercepted and sent to a selected route in the Route List Table. Numbers dialed will be integrated and if it is determined to be a toll information call, either preceded with an area code or without or with a leading digit 1 or not, the call will be sent to the route designated in programming.

200.76 LOOP BUTTON CO LINE ACCESS

A station not having a direct appearance for a CO line will receive incoming CO calls and transferred CO calls under the loop button. Only one call at a time can be connected to a keyset on the loop button. If more than one loop button is on a key set, the loop buttons may be conferenced together. If all programmed Loop buttons on a keyset are busy or have a CO call on hold, the party attempting to transfer a CO line to that station will receive busy tone and cannot transfer the call to that station. If a transfer is attempted, the CO line will recall the initiator immediately and the transfer recall timer will start.

CO lines are also presented to a Loop when dialing out using LCR or when using speed dial to dial out and the line chosen does not appear on the key station.

200.77 LOUD BELL CONTROL (LBC)

Two sets of relay-controlled contacts are provided to connect external signaling devices (optional). Each set of contacts can be programmed to follow the day and night ringing signals of any station.

The first Loud Bell Control (LBC) contact also serves as the External Night Ringing control contact. Loud Bell Control Contacts (one each) are provided with, and require the installation of, a PFT unit for each contact desired. (Max 2)

200.78 MEET ME PAGE

Users may answer a page call from any phone in the system by dialing a special code. The party who initiated the page must remain off-hook.

200.79 MESSAGE WAITING

Stations that are busy, unattended, or in DND can be left a message indication by other stations in the system. Up to five messages can be left at one keyset. Upon return to the station, the user can press the flashing MSG WAIT button to ring each party in sequential order.

200.80 MESSAGE WAITING REMINDER TONE

A key station with a message waiting can be reminded at a timed interval with a tone.

200.81 MUSIC ON HOLD

A music source, when connected to the system, provides music to all lines on Hold, parked calls, transferred calls and calls waiting to be answered by Uniform Call Distribution (UCD).

200.82 MUTE KEY

Pressing the MUTE button while in the speaker-phone mode or using the handset will disable the microphone but not affect the speech coming over

the speaker or handset. Pressing the illuminated MUTE button again will reactivate the microphone.

200.83 NAME IN LCD DISPLAY

This feature allows every extension (Key or SLT) the capability to program the users name, for that station, so that people using display telephones will see the name instead of the station number on their display. The name is programmed at each station by the user into station speed dial bin 00. When a name is programmed, the bin (00) is no longer used for station speed dial. The name may be up to seven (7) letters in length.

200.84 NIGHT SERVICE**A. Manual Operation**

The Attendant(s) can control the use of Night Mode manually by pressing the NIGHT (DND) button. An LED will indicate when the system is in Night Mode operation.

B. Automatic Night Mode Operation

The 96EX system can be programmed so that the system is automatically placed into night mode. A programmable weekly time schedule allows the system administrator to preset the time the system is placed into night mode and removed from night mode on a daily basis including weekend operation.

The Attendant(s) can override the Automatic Night mode schedule simply by pressing the NIGHT (DND) button.

C. Weekly Night Mode Schedule

A programmable weekly night mode schedule provides for 24 hour, 7 day a week automatic night mode operation. The system can be put into and out of night mode automatically on a daily basis.

D. Night Class of Service (COS)

The system allows each station to be assigned a different COS for night operation. The night COS goes into effect when the system is put into night mode manually or via the automatic schedule. Prevents the misuse of phones after hours.

E. Universal Night Answer (UNA)

Incoming CO lines can be programmed for Universal Night Answer (UNA). Stations which do not have access to a line during the day can answer that line while the System is in the Night Mode by dialing a UNA code.

F. Night Ringing Assignments

Each CO line may be individually programmed for Night ringing to other stations, to Hunt groups, UCD groups, Voice Mail groups, or off-net via speed dial. When the system is placed into night mode, manually or automatically, ringing will follow the night ringing assignments for each CO line.

G. External Night Ringing

The system can be programmed so that CO lines marked for UNA will activate Loud Bell Control contact #1 connected to an external ringing device when the system is placed into Night mode. (Requires a PFT w/LBC)

200.85 OFF-HOOK PREFERENCE**A. Auto Line Access**

Each station, key or SLT, may have their phone programmed to access a particular CO Line such as a private line or a line from a Group of CO lines upon going off-hook. This is useful in Centrex or PBX applications when station users have dedicated lines. Outside line dial tone is received just by going off-hook, without the need to dial an access code.

B. Auto Feature Access

In addition to auto line access Key Stations have the ability to have their off-hook preference select a DSS or feature button upon going off-hook or pressing the ON/OFF button.

C. Hot Line

Electronic Key Telephones may be programmed to immediately call or ring down a particular station or outside number upon going off hook. This is performed by programming the stations Off-Hook preference to activate a DSS or Speed dial feature key.

D. Intercom Access

When off-hook preference is enabled, at a key station, that station may still obtain intercom dial tone for accessing internal stations or other system features. This is done either by pressing an intercom button or dialing their own intercom station number prior to going off-hook.

E. User Programmable Preference

Based on a station programmable option Key stations may be given the ability to enable, disable or change their off-hook preference by dialing a code. This option can be denied in station programming on a per key station basis.

200.86 OFF-HOOK SIGNALLING

If a station has been programmed to receive direct outside line ringing and is busy on another call, that station will receive muted ring to indicate another call is ringing in. Additionally CO calls may be "camped-on" to a busy station and receive muted ringing.

200.87 OFF-PREMISE EXTENSIONS (OPX)

The Off-Premises Extension Board (OPX) provides 4 FCC registered 2500-type single line interface ports. This enables the use of 4 off-premise 2500 telephone sets. When an OPX board is installed, the maximum number of stations in the system is reduced by four. A precise tone plan is provided to OPX stations. An APL and Ring Generator are required when installing OPX Boards.

200.88 ON HOOK DIALING

The Key Telephone user can place calls without lifting the handset. If the speakerphone is disabled, the handset must be lifted to converse.

200.89 ON LINE PROGRAMMING

Changes to the system data base with the exception of the LCR data base can be made without interrupting normal system operation. Programming may be performed using a key station terminal connected to the system (sta 100) or via a external terminal either on-site or remotely.

200.90 PAGING**A. External Paging**

There is one external paging zone optionally available in the 96EX system. External Paging requires a two-digit dialing code. External paging requires the APL Board and an externally provided amplifier and paging system. One (1) make and one (1) break contact are provided with the page zone on the APL Board.

B. Internal Paging

There are four internal paging zones available in the 96EX system. A station can be in any or all zones or in no zone at all. Stations not assigned to a page group can still make page announcements, if allowed in station programming. Stations can be assigned to a page group in order to receive pages but not allowed to make page announcements.

C. Paging Access Restriction

Programming on a per-station basis, can deny any station the ability to make any type of page.

200.91 PAUSE TIMER

When dialing a speed number, a timed pause between digit sending can be placed in the number. The length of this pause can be programmed in the system database.

200.92 PBX DIALING CODES

The System will allow five one or two-digit access codes to be entered into memory. When one of these codes is dialed, this signals the KSU that toll restriction is to be applied at the next dialed digits after the code. If one of these codes is not dialed, toll restriction does not apply. This allows the dialing of PBX extensions 100, 110, 111, etc. This functions on lines marked as PBX type lines in programming.

200.93 PERSONALIZED MESSAGES

Each station (Key and SLT) can select a pre-assigned message to be displayed on the LCD of the Key Telephone calling that station. There are ten possible messages which can be displayed:

- VACATION
- RETURN MORNING
- RETURN AFTERNOON
- RETURN TOMORROW
- RETURN NEXT WEEK
- BUSINESS TRIP
- MEETING
- HOME
- ON BREAK
- LUNCH

A. Personalized Message Code on a Flex Key

This feature allows a key station user to program the pre-selected message code [78] under a Flex key. This speeds access of the pre-selected messages.

200.94 PHONE BOX

A Phone Box may be substituted for a telephone on a one for one basis. The phone box can be used to receive intercom announcements and also provide handsfree response. There is also a CALL button which will signal all stations programmed to receive phone box signalling (stations that have a programmed DSS flex button for the phone box station). One of these stations can respond to this signal by pressing the DSS/BLF button or dialing the intercom number of the phone box station. Two way conversation is then possible.

The Phone box also has a DND button that when enabled will blocking calls when privacy is needed. Back Ground Music may be presented to the Phone Box and can be controlled (on or off) by the attendant station.

200.95 POOL BUTTON OPERATION

The Pool Group Key is used primarily to access CO lines that do not appear on a station so that outgoing calls may be made. Pooled group keys are associated to CO line groups and may be programmed for use on any of the flexible line buttons that do not represent CO line appearances directly. CO lines are accessed in descending order of priority starting with the highest numbered available (not busy) CO line in a CO line group.

Stations may have as many POOL buttons as their are CO line groups (7). Multiple POOL buttons for the same group are also allowed.

200.96 PREFERRED LINE ANSWER

A station with Preferred Line Answer can answer any assigned outside, transferred, or recalling line, or queue callbacks by lifting the handset or pressing the ON/OFF button.

200.97 PRIVACY RELEASE

Privacy is insured on all communications in the system. If desired, the customer may elect to disable the Automatic Privacy feature. Thus allowing another station to join in on existing CO Line conversations.

A. Per Station Option

Each station may be programmed to give the station the capability to join an existing conversation simply by pressing the CO line button that is in use. A warning tone is presented to all parties when the station enters the conversation. The CO line must also have privacy disabled to allow the cut-thru.

B. Per CO Line Option

This feature allows each CO line to be individually programmed for privacy. This feature is useful for maintaining security on such lines as Data lines, Private lines, or special circuits requiring privacy. If privacy is disabled on a CO line then, while in use, another station may enter the conversation simply by pressing the CO line button. A warning tone is presented to all parties prior to actual cut-thru. The station attempting to enter the conversation must also have privacy disabled.

NOTE: A decrease in volume may occur on the CO line after the cut-thru occurs.

200.98 PRIVATE LINE

Private line programming allows certain lines to ring at a specific station only. When placed on Hold, these lines are active at the programmed station only. A private line can be transferred to other stations.

200.99 PULSE-TO-TONE SWITCHOVER

When commanded, the system will change the signaling on an outside line from dial pulse to DTMF (tone), allowing the use of common carriers behind a dial pulse outside line. This can be done manually when dialing, or can be stored within a speed dial number.

200.100 RANGE PROGRAMMING

The Starplus 96EX allows for range programming when programming Co lines and Stations. Range programming allows you to program all parameters alike for the entire range or you can change or modify a few items that will be copied to all members in the range.

200.101 REMOTE ADMINISTRATION

The Remote Administration feature allows authorized personnel to access the administration programming via a terminal device (portable terminal device or personal computer with communications software package).

The feature permits the review and entry of the customer database in the same manner as via the telephone at "admin" extension 100. The terminal device can be connected directly to the RS232 connector on the CPB board, or can be accessed by a telephone modem linking the CPB's RS232 connector (via a CO line) to a remote location.

200.102 REMOTE SYSTEM MONITOR AND MAINTENANCE**A. Remote System Monitor**

The Remote Monitor feature provides remote access to the installed system for diagnostic purposes. These capabilities benefit Service personnel enabling them to support the end user remotely. Different levels of access, via password, allows authorized personnel to trace, monitor and "up-load" critical information directly from the 96EX system. This provides a more accurate means of acquiring system information that leads to a quick resolution of problems that may occur. This is all done without interfering with ongoing call processing or normal system operation, and in many cases may be performed without a site visit. An external modem connected to the CPB RS232-C is required for remote access.

Capabilities allowed and reserved for this "High level troubleshooting" in addition are:

- Monitor Mode
- Enable & Disable Event "Trace"
- Dump "Trace Buffer" (up-load)

B. Remote System Maintenance

The Remote Maintenance feature allows the Interconnects' technical staff to review the systems configuration data and individual card slot configuration data. This can be done "on site" using a data terminal or remotely using modem to modem access to a remote data terminal. In both cases connection to the RS232C connection on the CPB is required.

200.103 SAVE NUMBER REDIAL (SNR)

Any number dialed on an outside line can be saved permanently to be used at any time. This number is saved until a new number is stored.

200.104 SINGLE LINE TELEPHONE (SLT) COMPATIBILITY

The 96EX system supports industry standard 2500 Type (DTMF) single line instruments. A maximum of 88 single line telephones may be installed and operate on the Starplus 96EX Hybrid Key Telephone System. SIB, APL and RG cards are required.

200.105 STATION MESSAGE DETAIL RECORDING (SMDR)

The Starplus 96EX Key Telephone System provides one industry standard RS-232C port for dual purpose use and a second port is optional for SMDR output, each allowing connection to an external printer or call accounting device. The system provides details on both incoming and outgoing calls. This feature is programmable to allow all calls or just outgoing long distance calls to be recorded. The system tracks calls by outside line, number dialed, time of day, date, station that placed the call and duration of call. Account codes may also be entered and recorded.

200.106 SPEAKERPHONE

Both Enhanced and Executive Key Telephones are equipped with a speakerphone. However, the speakerphone can be programmed to work in one of three ways:

- Normal speakerphone operation.
- Disabled for outgoing and incoming CO calls but handsfree talkback on intercom allowed.
- Headset operation allowed.

200.107 STATION CLASS OF SERVICE

Each station is assigned a Class of Service which governs that stations dialing privileges. Day Class of Service and Night Class of Service assignments to stations provide the system administrator additional control over station dialing, preventing misuse of phones after hours. Six uniquely defined Classes of Service are available for assignment to stations

on a per station basis and all six are available for day and night assignment. Station Class of Service works in conjunction with CO line Class of Service to provide the most flexible means for offering custom toll restriction. As a part of the Dialing privilege assignment through Class of Service the system offers two programmable Allow and Deny tables for additional customization of a toll restriction plan for a particular customer.

200.108 STATION SPEED DIAL

Each station user can program up to 20 frequently dialed numbers of up to 24 digits in length. Pauses, flash commands, pulse-to-tone switchover, and NO-DISPLAY characters take up digit spaces. There are a total of 1280 speed locations to be divided among all telephones on a first-come, first-serve basis.

Numbers are dialed by use of the SPD button and a two-digit code. This feature can additionally be assigned to any of the 22 buttons in the flexible button field on each keyset for one-button activation.

200.109 SYSTEM CAPACITY

A. Up to 24x48 Configuration

Without the Expansion KSU, the 96EX system will support a maximum of 24 outside CO circuits and 48 stations circuits.

B. Up to 40x96 Configuration

With the addition of the Expansion Cabinet the 96EX system can be expanded to a total of 40 CO lines and 96 stations. Also requires additional power supply (PS).

200.110 SYSTEM HOLD

When a line is placed on System Hold, any station in the system with access to that line can retrieve the call.

200.111 SYSTEM SPEED DIAL

Up to 80 commonly dialed numbers can be programmed into System Speed Dial for use by stations allowed this feature. These numbers can be up to 24 digits including pauses, flash commands, pulse-to-tone switchover, and no-display characters. The last 40 numbers will not be monitored by toll restriction.

200.112 TOLL RESTRICTION (TABLE DRIVEN)

The system provides a flexible means of providing toll restriction to internal stations of the Starplus 96EX key telephone system. Each station is assigned a Class of Service for day mode operation and one for night mode operation these station COS's work in conjunction with a CO line Class of

service to allow for customized toll restriction. Two (2) Allow and Deny tables along with four (4) special tables afford the system administrator to devise a variety of complex toll restriction or dialing privilege schemes.

200.113 TRANSFER RECALL

Screened and unscreened transfers will recall the initiating party if unanswered for a programmable length of time, and then if unanswered, will recall the attendant.

200.114 UNIFORM CALL DISTRIBUTION (UCD)

Eight Uniform Call Distribution (UCD) groups can be programmed, each containing up to eight 3-Digit station numbers. Each group is assigned a pilot number. When this number is dialed, the first available agent in that group is rung. Calls are routed to the station that has been on-hook for the longest period of time.

A. Alternate UCD Group Assignments

An alternate UCD group can be programmed so that if stations in one group are busy, the alternate group will be checked for an available station.

B. Overflow Station Assignments

An overflow station may be assigned to route callers in queue to a designated station after a specified time. The overflow station may not be one of the UCD group stations.

C. Incoming CO Direct Ringing

CO Lines can be programmed to ring directly into a UCD group. When all agents are busy and RAN is enabled, the system will answer the caller and present the 1st RAN announcement automatically.

D. Recorded Announcements (RAN)

Recorded announcement devices can be assigned to provide up to two different messages, if all stations in a UCD group are busy. The two messages are available to all eight (8) UCD groups in different configurations. A RAN device can provide an announcement to one caller at a time. Subsequent callers will be queued onto the message on a first-in basis.

E. Number of Calls in Queue Display

There are two methods of viewing UCD Group call queue status.

1. In-service UCD agents and the assigned overflow station will see the quantity of calls in queue on the LCD of their station for the UCD group of which they are a member. If every member of a UCD group is busy and calls are

in queue, the "XX CALLS IN QUEUE" display will be seen at all UCD members of that group.

NOTE: If a UCD member is taken out of the group (ie. DND, Call Forward, Unavailable etc.) they will not receive calls in queue information.

2. Any station not assigned in a UCD group can view the number of calls in queue for any given UCD Group. To view the number of calls in queue the station user dial's the Calls In Queue code (or presses a programmed FLEX button with this code) then enters the UCD group desired. The LCD will display, on a real time basis, the number of calls in queue for that group.

F. UCD Auto Wrap-Up w/ Timer

After completion of a UCD call (on-hook) the agent will not be subjected to another UCD call for the duration of the Auto Wrap-Up timer (regardless of the number of calls in queue), allowing the agent to finish call related work or access other facilities. This will allow agents to remove themselves from the group (ie. DND, Unavailable, Call Forward or originate another call). The auto wrap-up timer is programmed as part of the UCD data base. (System-wide)

G. UCD AVAILABLE / UNAVAILABLE

Stations programmed into a UCD group may log off and on to their assigned UCD group by dialing an Available/Unavailable code. When an agent is in the Available mode that agent will receive UCD calls in the normal manner. When an agent is in the Unavailable mode that agent will no longer receive UCD type calls, however may receive non-UCD calls. Agents that have logged off by going Unavailable will receive a visual reminder that they are logged off with a flashing LED and or a LCD display message.

200.115 UNIVERSAL NIGHT ANSWER (UNA)

Incoming CO lines can be programmed for Universal Night Answer (UNA). Stations which do not have access to a line during the day can answer that line while the System in the Night Mode by dialing a UNA code.

200.116 VOICE MAIL GROUPS (VM)

The Voice Mail feature automatically handles unanswered calls. Stations may forward calls to a voice mail group (for leaving mail) or may call the voice mail group directly (to retrieve mail) with no assistance from the attendant. Up to eight (8) voice mail groups can be configured in the system. Each group can contain up to eight voice mail stations, each of which interfaces with a port on a SIB or OPX card. Each voice mail "station" can be shared by a number

of actual users. An SIB or OPX Board and an APL Board and Ring Generator are required when utilizing the 96EX Voice Mail "In-Band" integration.

A. VM In-Band Signaling Integration

The 96EX system integrates with a wide range of Voice Mail systems through the use of "In-Band" signaling.

B. VM Message Waiting Indication

When Voice Mail has received a voice message for a user who has a station on the 96EX system, the VM connected to the system will leave a message waiting indication at the VM users station. When the station user retrieves their mail, the VM system will cancel the message waiting indication left at a station via a VM port.

The message waiting indication will appear on the programmed Voice Mail (group) button. If such a button has not been programmed, a voice mail message waiting indication will appear on the MSG WAIT button as a normal message waiting signal. SLT's will receive a voice mail message waiting as a normal message waiting indication (Message waiting lamp).

C. VM CO Disconnect Signal - Pass Thru

To avoid Voice Mail ports from being tied up, as a result of CO line callers abandoning the call or not exiting the VM system properly, a disconnect signal has been added to notify the VM system that a CO caller has abandon. "Silence" is provided to the VM port followed by "busy tone" to aid the VM system to recognize that an intercom caller has abandoned the call.

D. VM Tone Mode Calling Option

Voice mail systems and/or Automated Attendants can utilize the Calling Station Tone Mode option. This is useful when using supervised transfer or call screening options on voice mail or auto attendant(s) requiring ringback tone for proper call handling.

200.117 VOLUME CONTROLS

Both speaker and tone ringing volume can be separately adjusted by utilizing the two slide switches on the right side of the keyset.

SINGLE LINE TELEPHONE FEATURES

Single Line telephones have access to most of the system and station features listed in the previous section, however, the additional features listed below are unique to Single Line Telephones. (An APL and a Ring Generator in addition to SIB or OPX cards must be installed in the system for proper SLT operation)

200.118 ACCOUNT CODE

SLT stations may enter an account code, up to 12 digits in length, to identify calls for billing/tracking purposes. The account code may be entered either before the call or during the call (the outside caller is placed on hold while the account code is entered if during the call.). The account code is recorded on the SMDR printout. Account codes are non-verified and can vary in length from 1 to 12 digits.

200.119 AUTOMATIC LINE ACCESS

SLT's may have their station programmed to access a particular CO Line such as a private line or a line from a Group of CO lines upon going off-hook. This is useful in Centrex or PBX applications when station users have dedicated or individual lines. Outside line dial tone is received just by going off-hook, without the need to dial access codes.

200.120 CALL FORWARD

Single line telephones may direct intercom calls and transferred CO lines to be forwarded to another station. SLTs have access to all forwarding options that Key station user have:

- Call Forward - All Calls
- Call Forward - No Answer [2]
- Call Forward - Busy [3]
- Call Forward - Busy/No Answer [4]
- Call Forward - Off-Net [7]
- Preset Call Forward

200.121 CAMP ON

A busy station can be notified that an outside line is on hold and waiting for them. The busy station is notified of this by a beep tone. Single line telephones can receive a camp on indication or initiate one by using an access code.

200.122 CONFERENCE

An SLT user can initiate a conference with an outside line and one other internal station.

200.123 CONFERENCE /WITH PERSONAL PARK

Single Line Telephones (SLT) can initiate a conference between two outside (CO) calls. The Personal Park feature is used in conjunction with the SLT conference code to make this possible. A combination of features are derived from these new dial codes (Personal Park, Flip/Flop, and Multi-line Conference).

200.124 DIRECT OUTSIDE LINE ACCESS

Single line telephones can access outside lines by dialing CO line group access codes 9 or 81-87.

200.125 DIRECT OUTSIDE LINE RINGING

Single line telephones can be set up to receive direct outside line ringing. SLTs may be programmed to receive incoming CO Ringing on more than one CO line. However, an SLT can answer only ONE call at a time. If a SLT is busy when a CO call rings in, no notification will be given to that SLT station.

200.126 DIRECTED CALL PICK UP

Tone ringing intercom calls, Initial Ringing CO calls and transferred outside line calls to specific stations can be picked up by single line telephones. For this type of pickup, the stations do not have to be in the same pickup group.

200.127 DO NOT DISTURB

Each telephone user can be allowed to place their phone in Do No Disturb. The user will receive error tone if they are not allowed this feature. They will also receive a confidence tone when lifting the handset to remind them they are in Do Not Disturb. The attendant can override a station in DND.

200.128 GROUP CALL PICK UP

Tone ringing intercom calls and transferred outside line calls can be picked up by single line telephones by dialing a special pickup code. The telephones must be in the same pickup group.

200.129 INTERCOM CALLING

Single line telephones can make and receive intercom calls.

200.130 MESSAGE WAITING/CALL BACK

Single Line Telephones calling a station that is busy, idle, or in Do Not Disturb can leave a message waiting indication to signal the station to call back.

200.131 MESSAGE WAITING INDICATION

Industry standard message waiting single line telephones can have up to five (5) message waiting indications left for them, from other stations. The message waiting LED will flash at the called station.

200.132 NIGHT SERVICE

When outside lines are marked UNA and the system is placed into night service, a single line telephone can answer incoming calls on lines it does not normally have access to by dialing [7] [5]. An external ringing device must be provided.

200.133 OFF-HOOK PREFERENCE

SLT's may have their station programmed to access a particular CO Line such as a private line or a line from a Group of CO lines upon going off-hook. This is useful in Centrex or PBX applications when station users have dedicated lines. Outside line dial tone is received just by going off-hook, without the need to dial access codes.

200.134 PERSONAL PARK

Single line telephones can be connected to two calls (Intercom or CO lines) at the same time and "flip/flop" between the two calls. This can be performed with originated or received calls. This feature is also used with SLT multi-line conference feature.

200.135 QUEUING

Single line telephones can be placed in a queue awaiting the first available outside line in a group to become available.

200.136 STATION SPEED DIAL

Each SLT user may program up to 20 individual speed dial numbers. Each speed dial number can be up to 24 digits in length. There are a total of 1280 speed locations to be divided among all telephones. If single line telephones are to be allowed this feature, an APL board must be installed.

200.137 SYSTEM SPEED DIAL

Each SLT user can be allowed access to system speed dial numbers on a programmable basis. If single line telephones are to be allowed this feature, an APL board must be installed. The last forty system speed numbers override toll restriction.

200.138 TRANSFER

Outside lines may be transferred by or to single line telephones. These transfers can be either announced or unannounced.

ATTENDANT FEATURES

200.139 ATTENDANT DISABLE OUTGOING ACCESS

The first attendant can disable CO lines, preventing outgoing access to those lines. This is useful for removing a faulty line from service, or for reserving CO lines for important use. All stations that can normally make calls on the lines are affected, but incoming calls are not affected. A CO line may be disabled while it is being used; when the trunk becomes idle, further outgoing access will be prevented.

200.140 ATTENDANT OVERFLOW

System programming allows the attendant station to be programmed so that if the attendant is busy or not there, the call will be automatically forwarded to another predetermined station, VM Group, Hunt Group or UCD group after a programmed period of time. (Refer to Call Forward, Station and Preset)

200.141 ATTENDANT OVERRIDE

Attendant stations may override a busy station or ring a station in DND. While busy, pressing the override key provides override tone and a five second delay before voice cut-through to the called party occurs, automatically placing any outside line call on Hold. The Attendant Override function may be programmed on to a flex button and can be enabled or disabled in programming.

200.142 ATTENDANT POSITION

The system identifies a maximum of three programmable stations as attendants for line recalls and attendant features. The first programmed attendant can enter system date and time information as well as System Speed numbers from this position without entering the programming mode. The 96EX System is placed in Night Service by any programmed attendant pressing the NIGHT (DND) button.

200.143 ATTENDANT RECALL

A held CO call left unattended by a station will recall the attendant(s) after a programmable period of time has elapsed. A recalling CO line flashes at a distinctive rate that identifies the originating station of the unanswered call.

200.144 AUTOMATIC NIGHT MODE

In addition to the attendants capability to place the system into and out of night mode manually, by pressing the Night key, an automatic night mode schedule has been added to the system. The automatic schedule is set in data base programming on a week day basis, including Saturday and Sunday. The Attendant can override the automatic schedule by pressing the NIGHT (DND) button.

200.145 INCOMING CO LINE OFF-NET FORWARD

Allows the first attendant to forward incoming CO calls to an Off-Net location. The attendant must have a direct appearance of the CO line to be forwarded. Forwarding can be established on a per CO line group basis, or all CO lines may be simultaneously forwarded to an off-net location.

200.146 TIME AND DATE PROGRAMMING

This feature allows the first programmed attendant to set the time and date without entering the programming mode.

ATTENDANT W/DSS/DLS FEATURES

200.147 ATTENDANT SEARCH

Allows a user to make a series of intercom calls without hanging up the handset. An intercom connection is switched to another station whenever a DSS key is pressed. Pressing the next DSS key terminates the previous intercom call.

200.148 BUSY LAMP FIELD INDICATORS

Each station key on the DSS console has a corresponding indicator which shows whether the station is idle or busy. The indicator is lit when the station is busy and unlit if the station is idle. A station in DND mode is shown by a flashing indicator.

200.149 DIRECT STATION CALLING

Enables the user to make an intercom voice call to any key telephone in the system. Permits you to automatically put an outside caller on hold and simultaneously make an intercom call to an internal station. Also allows you to transfer an intercom call or outside call that is on hold to another station.

200.150 MAPPING OPTIONS

Each Attendant may have up to three (3) DSS/DLS terminals programmed to work with one attendant station. Each DSS terminal can be programmed in one of five ways:

- MAP 1. CO lines 1-24 appear in sequential order with the bottom 6 rows of buttons programmed as the following features: UCD groups 1-8, Call Park Zones, External & Internal Page Zones, Attendant Override, Release, and Account Code enter.
- MAP 2. Stations 100-147 appear in sequential order.
- MAP 3. CO line buttons 1-12 and stations 100-123 appear in sequential order with the bottom 3 rows of buttons programmed as the following features: Internal and External Page Zones,

Call Park, UCD, Release, and Attendant Override.

- Map 4. Stations 148-195 appear in sequential order.
- Map 5. CO lines 1-40 appear in sequential order and the bottom 8 buttons are flexible.

CO Line ringing on Map 1,3,4 is determined by CO Line Ringing Assignments.

200.151 RELEASE KEY

Allows the user to disconnect calls while off-hook, speeding up call handling time (MAP 1,3 only).

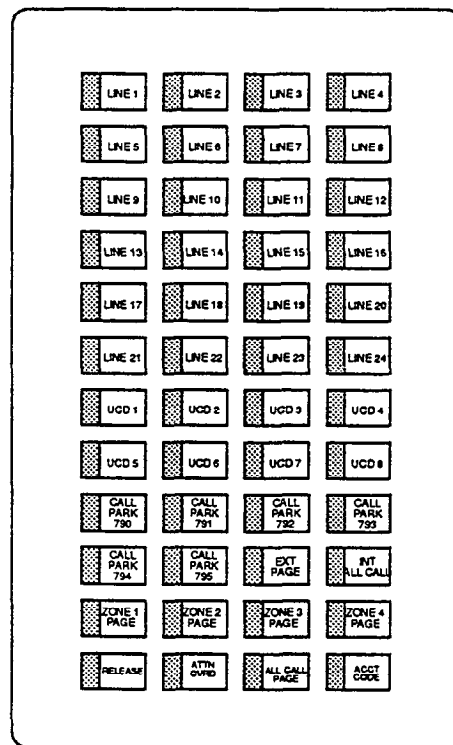

DSS/DLS Console Map 1

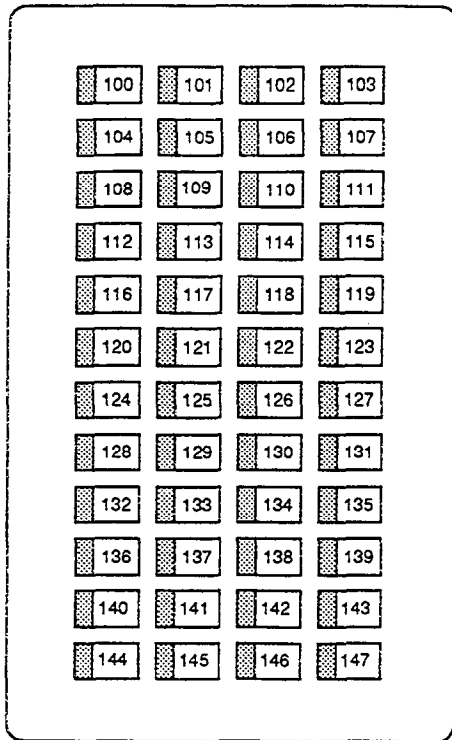

DSS/DLS Console Map 2

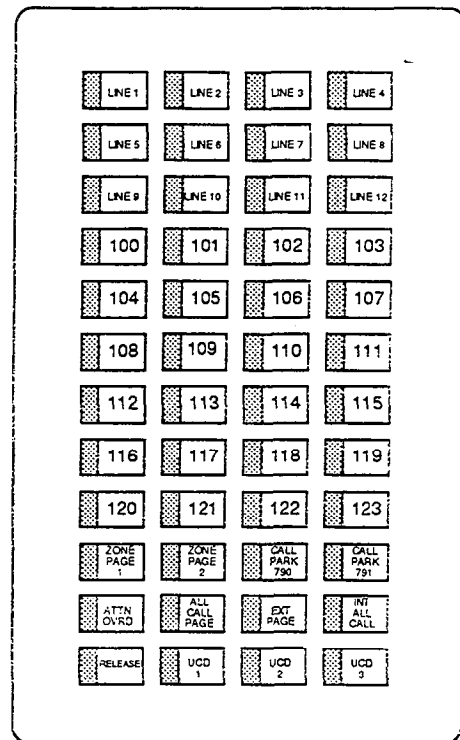

DSS/DLS Console Map 3

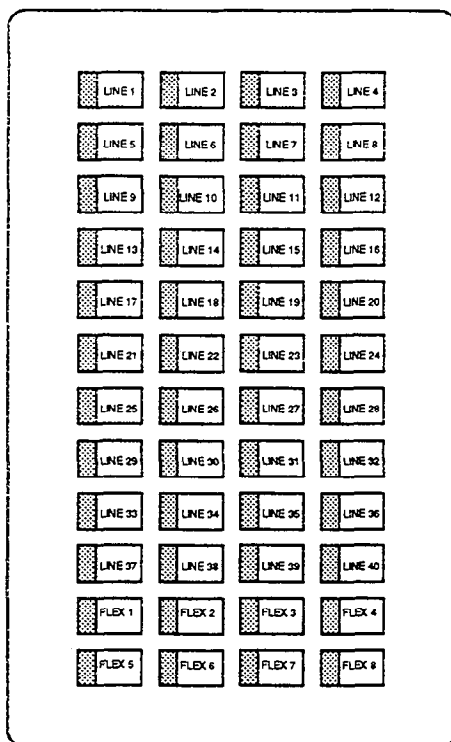

DSS/DLS Console Map 4

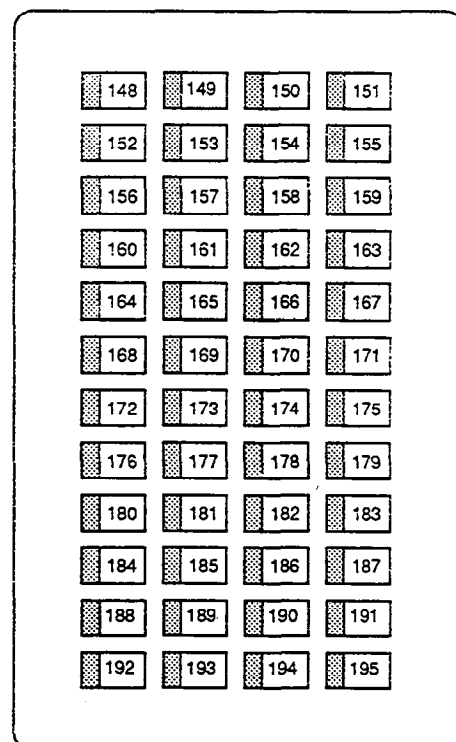

DSS/DLS Console Map 5

SECTION 300

FEATURE OPERATION

300.1 INTRODUCTION

The Starplus 96EX System has a wide variety of features and flexible programming, allowing each telephone user to program his/her telephone to meet his/her own individual needs.

This section of the manual contains the operating instructions for key telephone and Single Line users and includes an illustration of the key telephone used in the Starplus 96EX system and description of the keys on the telephones and their functions. It is designed to provide step-by-step instructions for operating the key telephones and Single Line telephones in the system. Visual and audible cues which accompany the various steps in the operation of the features are also include

Literature similar to these operating instructions has been prepared for use by the customer in the form of Station, SLT, and Attendant User's Guides.

300.2 KEY TELEPHONE STATION FEATURES

Each 96EX key station provides the following keys, indicators and features:

HANDSET AND SPEAKER are located at the left side of the front panel. A handset is provided to allow confidential conversation when desire Lifting the handset from its cradle (going off-hook) disengages the station's built-in speaker.

The speaker is located directly below the center portion of the handset. The station may be operated with the handset on-hook. When this occurs, audio is transmitted to the station user through the station's speaker.

SPD button provides you with access to speed dialing, save number redial and last number redial. This button is also used to access speed dial and flex button programming.

FLASH button is used to terminate an outside call and restore dial tone without having to hang up the handset. It is also used to transfer calls behind a PBX or Centrex within those systems.

HOLD button enables you to place an outside caller on hold.

ON/OFF button enables you to make a telephone call without lifting the handset. It turns the telephone on and off when using the speakerphone.

CONFERENCE (CONF) button is used to establish and build conference calls.

TRANSFER (TRANS) button is used to transfer an outside call from one station to another.

CALL FWD button allows you to forward your calls to another station.

MESSAGE WAIT (MSG WAIT) button allows you to initiate a message waiting indication at stations that are busy, unattended, or in Do Not Disturb. Message Waiting Callback request left at your station will be indicated by a flashing Msg Wait LED.

FLEXIBLE BUTTONS are used to access idle outside lines, provide DSS/BLF for internal stations, access speed dial number and activate features. These buttons are programmed by the individual station user. The default flex feature buttons are described below.

CALL BACK (flex) button allows you to initiate an automatic call back request to another busy station. As soon as that station becomes idle, the station that left the call back request is signalled. A flex button must be assigned to use this feature.

PICK UP (flex) button allows you to pickup a tone ringing intercom call, transferred, incoming, or recalling outside line call to a specific unattended station either by group or directed call pick-up.

MUTE (flex) button allows you to switch the built-in microphone on or off when using the speakerphone, or the handset microphone when using the handset. A flex button must be assigned to use this feature.

LINE QUEUE (flex) button allows you to queue onto an outside line when all lines in a group are busy. Your station is placed in queue awaiting a line in the same group to become available. A flex button must be assigned to use this feature.

DO NOT DISTURB (DND) (flex) button allows the user to place his/her telephone into a Do Not Disturb mode to eliminate incoming outside line ringing, intercom calls, transfers and paging announcements. The station in DND can use the telephone to make normal outgoing calls. On Attendant stations, this button becomes the system Night Mode button. A flex button must be assigned to use this feature.

CAMP-ON (flex) button enables you to alert a busy party that an outside line is on hold and waiting for them. A flex button must be assigned to use this feature.

OUTSIDE CALLS are announced by a tone signal repeated every 3.2 seconds. The corresponding outside line indicator will flash slowly.

INTERCOM CALLS can be tone ringing or voice announce. If it is voice announced, the receiving station will receive 3 bursts of tone prior to the announcement. If it is a tone ringing call, the receiving station will hear a tone ring every 2.4 seconds.

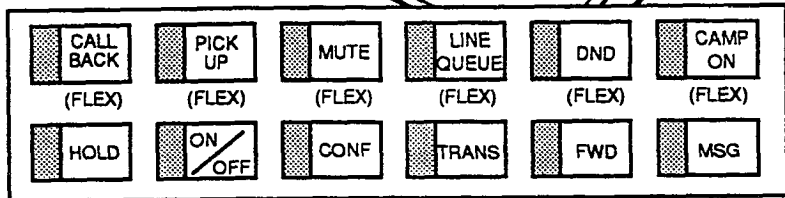

Feature Buttons

Figure 300-1 Starplus 96EX Executive Key Telephone

Table 300-1 Starplus 96EX System Numbering Plan

100-195	Station Intercom Numbers	898	UCD Available/Unavailable
280	Call Back (Flex Button Programming)	9	LCR or CO Line Group 1 (if LCR is disabled)
281	Pick Up	0	Attendant (1st programmed Attendant)
282	Mute (Flex Button Programming)	*1	Internal Page Zone 1
283	Line Queue (Flex Button Programming)	*2	internal Page Zone 2
284	Do Not Disturb (Flex Button Programming), Night Service (attendant stations)	*3	Internal Page Zone 3
285	Camp-On (Flex Button Programming)	*4	Internal Page Zone 4
286	Headset Mode	*5	Internal All Call Page
287 BB	Off-hook Preference Programming	*6	External Page
288	Attendant Override (Flex Button Programming)	*9	Meet-Me-Page Answer
289 XXX 0	Turn BGM OFF at a phone box (1st programmed Attendant)	*0	All Call Page (Internal & External)
289 XXX 1	Turn BGM ON at a phone box (1st programmed Attendant)	#1	SLT DND Enable / Disable
294	Executive Override	#2 XXX	SLT All Call Forward
295	Name in Display Programming	#22 XXX	SLT No Answer - Call Forward
296	CO Line Off-Net Forward (1st programmed Attendant)	#23 XXX	SLT Busy - Call Forward
297 89U	UCD Calls in Queue Display	#24 XXX	SLT Busy / No Answer - Call Forward
298	Disable Outgoing CO Line Access	#27 YY	SLT Off-Net - Call Forward
391	SLT Conference W/ Personal Park	#2	Call forward cancel (all types)
392	Personal Park	#3 YY	SLT Station Speed Dial Programming
5# XXX	Tone Mode Ring Option	#4	Message Wait enable
590-597	Hunt Group Pilot Numbers 1-8	#5	Message Wait return
60	Voice Mail enable MSG Wait	#6	SLT Group Call Pick-up
61	Voice Mail cancel MSG Wait	#7 XXX	SLT Directed Call Pick-up
690-697	Voice Mail Group Pilot Numbers 1-8	#79 C	Call Park Pickup (Key and SLT)
74	LCR Queue Cancel	#8	SLT Clear - Call Forward, DND, Personal Messages
75	Universal Night Answer	#9 YY	SLT Speed Dial Access
76	Time & Date Programming (1st programmed Attendant)	#0	SLT Flash Command to CO Line
77	Background Music	#*	SLT Camp-on (call wait)
78 ZZ	Personalized Messages	##	SLT CO Line Queue
78 00	Clear Personalized Messages	[FWD]XXX	Station Call Forward-All
790-795	Call Park (system)	[FWD]2XXX	Station No Answer-Call Forward
80	Account Code Enter	[FWD]3XXX	Station Busy-Call Forward
81	CO Line Group 1 (if LCR is enabled)	[FWD]4XXX	Station Busy/No Answer-Call forward
82	CO Line Group 2	[FWD]7	Station Off-Net Call forward
83	CO Line Group 3	[SPD] YY	Speed Dial Access (00-19 Station) (20-99 System)
84	CO Line Group 4	[SPD] *	Save Number Redial
85	CO Line Group 5	[SPD] #	Last Number Redial
86	CO Line Group 6		
87	CO Line Group 7		
88	All CO line Groups (CO Line Off-Net Forward)		
890-897	UCD Group Pilot Numbers 1-8		

XXX = Intercom Station Numbers
 U = UCD Group Number 1-8
 YY = Speed Dial Bin numbers
 C = Call Park Location 0-5
 ZZ = Personalized Messages
 BB = Button Number

SYSTEM AND STATION FEATURES**300.3 ANSWERING AN OUTSIDE CALL**

- A. Lift handset.
- B. Press slow flashing outside line button, or Loop button. (If your telephone is programmed with Preferred Line Answer, you may answer an outside line by lifting the handset.)

300.4 PLACING AN OUTSIDE CALL ON HOLD

- A. If your system is programmed for Exclusive Hold Preference, press HOLD button once for Exclusive Hold and twice for System Hold.
- B. If your system is programmed for System Hold Preference, press HOLD button once for System Hold and twice for Exclusive Hold.

300.5 ANSWERING A RECALL

When an outside line has remained on hold for an extended period of time, you will be reminded with a recalling ring.

- A. Press outside line, Loop or Pool button flashing at very fast rate.
- B. Lift handset to converse.

300.6 ACCOUNT CODES

When connected to an outside line call:

- A. Press pre-programmed account code button (Refer to Programming Flexible Buttons).
- B. Dial account code up to 12 digits. (The other party will not hear the digits being dialed).
- C. If account code is less than 12 digits, an [*] must be entered to return to the call.
- D. If account codes are forced the account code must be entered prior to dialing the outside number.

300.7 DISABLE OUTGOING CO LINE ACCESS

The First Attendant station can disable CO lines, preventing outgoing CO calls.

- A. Lift handset or press ON/OFF button.
- B. Dial [298]. Confirmation tone is heard
- C. Depress the line button(s) of the CO Line(s) to be disable Confirmation tone is heard and the CO Line Button LED is flashing.

To re-activate the CO Line(s), repeat the steps followed to disable it.

300.8 PLACING AN OUTSIDE CALL (Automatic Line Selection)

- A. Press outside line or Pool button. ON/OFF button LED will light and dial tone will be heard.
- B. Dial desired party.
- C. When called party answers, lift handset to converse or use speakerphone.

Station user may also dial the individual trunk group access code to access an outside line.

300.9 BACKGROUND MUSIC (Optional)

- A. Dial [77] on the dial pad, or press the pre-programmed flex button. (music is heard)
- B. Dial [77], or press the pre-programmed flex button again, and music is discontinued.
- C. When you pick up the handset or press the ON/OFF button, music is discontinued automatically.

300.10 AUTOMATIC SELECTION

Pressing an outside line button, Loop or Pool button; a Speed button; a Station button; or dialing a number in the Starplus 96EX Numbering Plan will automatically activate the speakerphone and light the ON/OFF button, if your keyset is programmed as a speakerphone.

300.11 CALL BACK

If you dial a telephone that is busy or in DND and want to activate Call Back:

- A. Press pre-programmed CALL BACK button. (Refer to flex button programming.)
- B. Hang up.
- C. When busy station hangs up, you will be signaled.
- D. Answer call; station you called will then be signaled. (If your station is busy when signaled, an automatic MSG WAIT will be placed at your phone.)

Only one Call Back request can be left at a station; the second request will be converted to a message wait call back request. A flex button must be programmed for this feature to operate.

300.12 CALL FORWARD: STATION**A. Call Forward - All Calls**

If you have been given the ability to forward your calls:

- A. Lift handset or press ON/OFF button.
- B. Press CALL FWD button.
- C. Press station key or dial intercom number where calls are to be forwarded, including

UCD, Voice Mail, and Hunt group pilot numbers.

- D. Replace the handset or press the ON/OFF button.

Line Queue, Call back requests, message wait requests, and pre-selected messages are cancelled when a station activates call forward. Call back requests are not allowed at a station where a call is forwarded. CO Line calls can be transferred by the receiving station back to the original forwarded station. A station in the call forward mode may still make outgoing calls.

To Remove Call Forwarding:

- A. Lift handset or press ON/OFF button.
- B. Press CALL FWD button.
- C. Hang up.

B. Call Forward - Busy

If you have been given the ability to forward your calls:

- A. Lift the handset or press ON/OFF button.
- B. Press CALL FWD button.
- C. Dial the Call Forward Busy code [3] on the dial pad.
- D. Dial the 3-digit extension number where calls are to be forwarded. Confirmation tone will be heard.

To cancel Call Forwarding:

- A. Lift the handset or press the ON/OFF button.
- B. Press the CALL FWD button.

C. Call Forward - No Answer

If you have been given the ability to forward your calls:

- A. Lift the handset or press ON/OFF button.
- B. Press CALL FWD button.
- C. Dial the Call Forward No Answer code [2] on the dial pad.
- D. Dial the 3-digit extension number where calls are to be forwarded. Confirmation tone will be heard.

To cancel Call Forwarding:

- A. Lift the handset or press the ON/OFF button.
- B. Press the CALL FWD button.

D. Call Forward - Busy/No Answer

If you have been given the ability to forward your calls:

- A. Lift the handset or press ON/OFF button.
- B. Press CALL FWD button.
- C. Dial the Call Forward Busy/No Answer code [4] on the dial pad.

- D. Dial the 3-digit extension number where calls are to be forwarded. Confirmation tone will be heard.

To cancel Call Forwarding:

- A. Lift the handset or press the ON/OFF button.
- B. Press the CALL FWD button.

E. Call Forward - Off-Net (via speed dial)

In a speed dial bin, store the number of the off-net location where calls are to be forwarded. Follow instructions provided for storing station or system speed dial numbers.

Allows stations to forward intercom and transferred CO calls to an off-net location.

- A. Lift handset or press ON/OFF button.
- B. Press CALL FWD button.
- C. Dial [7]. Then dial the speed bin number that contains the number where calls are to be forwarded,

or

- D. Press the pre-programmed button for the speed bin.
- E. Confirmation tone is heard. CALL FWD button LED is flashing.

Line Queue, Call back requests, message wait requests, and pre-selected messages are cancelled when a station activates call forward. Call back requests are not allowed at a station where a call is forwarded. CO Line calls can be transferred by the receiving station back to the original forwarded station. A station in the call forward mode may still make outgoing calls.

Canceling Off-Net Forwarding

- A. Lift handset or press ON/OFF button.
- B. Press CALL FWD button. CALL FWD button LED is extinguished.

F. Call Forward - UCD Groups

If you have been given the ability to forward your calls:

- A. Lift the handset or press ON/OFF button.
- B. Press CALL FWD button.
- C. Dial the desired code:
 - [2] = no answer calls
 - [3] = busy calls
 - [4] = busy and no answer calls.

NOTE: Skip step C. for immediate forwarding.

- D. Dial the 3-digit UCD group pilot number (890-897) for the group (1-8) where calls are to be forwarded. Confirmation tone will be heard.

To cancel Call Forwarding:

- A. Lift the handset or press the ON/OFF button.
- B. Press the CALL FWD button.

G. Call Forward - Voice Mail Groups

Intercom and Transferred CO callers may be routed directly to your mail box by forwarding your phone to a voice mail group. Callers will then be greeted by your personal voice mail greeting if available.

If you have been given the ability to forward your calls:

- A. Lift the handset or press ON/OFF button.
- B. Press CALL FWD button.
- C. Dial the desired code:
 - [2] = no answer calls
 - [3] = busy calls
 - [4] = busy and no answer calls.

NOTE: Skip this step for immediate forwarding.

- D. Dial the 3-digit Voice Mail group pilot number (690-697) for the group (1-8) where calls are to be forwarded. Confirmation tone will be heard.

To cancel Call Forwarding:

- A. Lift the handset or press the ON/OFF button.
- B. Press the CALL FWD button.

H. Call Forward - Hunt Groups

If you have been given the ability to forward your calls:

- A. Lift the handset or press ON/OFF button.
- B. Press CALL FWD button.
- C. Dial the desired code:
 - [2] = no answer calls
 - [3] = busy calls
 - [4] = busy and no answer calls.

NOTE: Skip this step for immediate forwarding.

- D. Dial the 3-digit Hunt group pilot number (590-597) for the group (1-8) where calls are to be forwarded. Confirmation tone will be heard.

To cancel Call Forwarding:

- A. Lift the handset or press the ON/OFF button.
- B. Press the CALL FWD button.

300.13 CALL FORWARD: PRESET

If a CO Line forwarded by Preset Call Forward encounters a manually forwarded station (Call Forward - Station), or a station in DND, then the incoming CO Line will bypass that station and forward to the next in the chain. If that station is the last in the chain, then the call will not forward

any further and will continue to ring at that station until answered or terminate.

300.14 CALL FORWARD: CO LINES

A. Incoming CO Lines Off-Net (via speed dial)

Allows the first attendant station to forward incoming CO calls to an off-net location.

In a speed dial bin, store the number of the off-net location where calls are to be forwarded. Follow instructions provided for storing station or system speed dial numbers.

- A. Dial [296].
- B. Dial the CO group access code for the CO Line group to be forwarded.
 - 81=CO Group 1
 - 82=CO Group 2
 - 83=CO Group 3
 - 84=CO Group 4
 - 85=CO Group 5
 - 86=CO Group 6
 - 87=CO Group 7
 - 88=All CO Line

- C. Dial the speed bin number that contains the number where calls are to be forwarded or press the programmed button for the speed bin. Confirmation tone is heard.

Canceling Off-Net Forwarding

- A. Dial [296].
- B. Dial the CO group access code.
- C. Dial [#]. Confirmation tone is heard

300.15 CALLING STATION TONE MODE OPTION

Allows a calling station to override a called stations H or P intercom switch settings.

When placing a call to a station and Tone ringing is desired:

- A. Dial [5#].
- B. Dial 3-digit station extension or press DSS button of desired station. (call tone rings station).

300.16 CALL PARK

To place an outside call on hold and consult with, page, or call an internal party and/or transfer the outside call.

While connected to an outside line:

- A. Press TRANS button. The caller is put on Exclusive hold.
- B. Dial parking location (790 to 795). Hear confirmation tone.

- C. If you hear busy tone, press TRANS and dial another parking location.

Retrieving a Parked Call

- A. Lift handset or press ON/OFF button.
- B. Dial pound [#].
- C. Dial parking location (790 to 795) where the call was parked.

300.17 CALL PICK-UP: GROUP

When intercom tone ringing, transferred outside line ringing, or recall ringing is heard at an unattended telephone:

- A. Lift the handset or press the ON/OFF button.
- B. Dial [281] on the dial pad or press the pre-programmed PICK UP button to be connected to the calling party.

NOTE: You must be in the same pick up group as the ringing telephone to pick up the call. Refer to the flex button programming.

300.18 CALL TRANSFER

Outside lines can be transferred from one phone to another within the system. The transfer can be either screened (announced) or unscreened to either an idle or busy station, or UCD or Hunt Group.

Screened Transfer

- A. While connected to an outside line, press station button where call is to be transferred (if programmed on your telephone), or press TRANS button and dial station number (100 to 195).
- B. The called extension signals according to the intercom signal switch position.
- C. When that extension answers, announce the transfer.
- D. Hang up to complete transfer.

Unscreened Transfer

When the called extension begins to signal, hang up to transfer the call (Recall timer starts).

Transfer Search

- A. When attempting to locate a party, press a station key to signal a station or press the TRANS button and dial station desired.
- B. If the party is not located, press another station key to continue the search, or press the TRAN button and dial the station number.
- C. If the party is not located, press the TRANS button again and dial another station number to continue the search.
- D. When the called party answers, hang up to complete the transfer.

Answering a Screened Transfer

- A. Your intercom will be signaling according to the intercom signal switch position.
- B. Answer the intercom and receive the transfer notice.
- C. Press the outside line button or loop button flashing on hold.

300.19 TRANSFERRING CO CALLS TO A STATION FORWARDED TO VM

While connected to a CO line:

- A. Press the TRANS button and dial the extension number of the station forwarded to voice mail.
- B. The transferring station hangs up. The CO call will be directed to the mailbox of the forwarded station.

NOTE: If the transferring station attempts to supervise the transfer or just waits until the voice mail system answers, then it becomes necessary to reaccess the CO line and re-transfer them and go on-hook before the voice mail system answers. This will ensure that the CO party will hear the personal greeting of the mailbox user and any applicable instructions.

300.20 CAMP-ON

If you call a station that is busy and wish to alert them to your call:

- A. Press the pre-programmed CAMP ON button.
- B. Called station will receive two bursts of ringing.
- C. Wait for their response
- D. When called party answers, consult with them or hang up to transfer the call.

If a station is in DND, only the attendant can Camp On using the attendant override feature. A flex button must be programmed for this feature to operate. Refer to the flex button programming.

Answering a Camp On

If you are on a connected call, hear two bursts of muted ringing, and your CAMP ON button is flashing, you have a call waiting for you.

- A. To answer, press the CAMP ON button.
- B. Any outside line you are connected to will be placed on hold. You may converse with the station placing the call.
- C. Press flashing outside line button, if a call is being transferred.

If you do not have a pre-programmed Camp-On button either:

- A. Go on-hook with present call. Camp-On will ring through, or
- B. Place present call on hold. Then go on-hook. Camp-On will ring through.

300.21 CO LINE ACCESS

To access outside line:

- A. Press idle CO line button, Pool button, or dial CO line group access code or LCR access code.
- B. Dial number desired for outside call.
- C. Lift handset to converse or use speaker-
phone.

300.22 QUEUING

A station can queue only one line at a time. If you see that a particular outside line is busy and you wish to be placed on a list waiting for that line to become available:

To Place a Queue

- A. Press desired busy outside line button or pool button. (Busy tone is heard)
- B. Press pre-programmed LINE QUEUE button. Refer to flex button programming. A flex button must be programmed for this feature to operate.
- C. Hang up.

To Answer a Queue

If you hear ringing and an outside line of the line group (or a Loop or Group Key), you queued onto is slow flashing:

- A. Lift handset.
- B. Press flashing outside line button to answer.

If your station has been programmed for Preferred Line Answer, you will have the line automatically upon lifting the handset.

300.23 CONFERENCE COMBINATIONS

Only stations that have conference enabled will be able to institute a conference.

- Add-on Conference: Four internal and one external or five party internal
- Multi-Line Conference: One internal and two external.

Establishing a Conference

A maximum of five parties can be included in a conference. The internal party must lift the handset.

- A. Lift handset.
- B. Select intercom station or dial desired outside party.

- C. When called party answers, press CONF button.
- D. Add next conference party by selecting another outside line or intercom station.
- E. When party answers, press CONF button twice.
- F. All parties are connected.

Exiting a Conference (Controller only)

There are three methods of exiting a conference:

- A. Press the ON/OFF button to ON, press the MUTE button, and replace the handset (to monitor a conference).
- B. Press HOLD button to place outside parties on hold. Hold timer starts. If one of the two parties is internal, that party will be dropped.
- C. Press CONF and hang up or press the ON/OFF button to leave the other conference parties still connected in an unsupervised conference. CONF button will flash and timer will start. There will be a warning tone before the other parties are dropped.

Re-entering a Conference

When the controller re-enters the conference, the disconnect timer is reset.

- A. Lift handset to re-enter a monitored conference.
- B. To re-enter a conference placed on hold, repeat steps for establishing a conference.
- C. To re-enter an unsupervised conference, lift handset and press flashing CONF button. The CONF button lights steady and confirmation tone will be heard.

Terminating a Conference

To terminate a conference the conference initiator who is actively in the conference replaces handset or push ON/OFF button to OFF. To terminate an unsupervised conference, press the flashing CONF button while on hook, all parties will be dropped.

300.24 DIRECTED CALL PICK-UP

When incoming, transferred, or recalling outside line ringing, intercom ringing, or Camp On ringing is heard at an unattended telephone:

- A. Dial the station number of the known ringing telephone.
- B. Receive ringback tone, or call announce tone.
- C. Press the pre-programmed PICK UP button to answer the call.

User must have access to the specific outside line or a Loop key to do a directed call pickup. A flex

button must be programmed for this feature to operate. Refer to flex button programming.

300.25 DIRECT INWARD SYSTEM ACCESS (DISA)

- A. Call the phone number or the system administrator specified of the DISA line.
- B. The system answers and returns intercom dial tone.
- C. Enter the DISA access code also specified by the system administrator, if applicable.
- D. Dial tone is returned.

To place an outgoing call:

- A. Dial a group access code: 9, 81 - 87.
- B. CO Dial tone is returned.
- C. Dial the desired telephone number.

NOTE: LCR cannot be accessed from DISA. If LCR is enabled, DISA users may dial 81 to access lines in trunk group 1.

NOTE: The conference timer (Refer to Sec. 610.7) will monitor a DISA "trunk-to-trunk" call and release the lines one (1) minute after the time expires.

To reach an internal station:

- A. Dial the 3-digit station number. Ringback tone will be heard.
- B. Converse when party answers.

NOTE: If the station dialed is unattended, busy or in DND, intercom dial tone will be returned (after the Preset Call Forward Timer expires) Refer to Sec. 600.10

300.26 DO NOT DISTURB

Activating Do Not Disturb:

- A. If you have been given the ability to place your phone in Do Not Disturb, press the pre-programmed DND button.
- B. DND button lights steady.

The DND button can be pressed while the phone is ringing to stop the ringing. (Refer to One-Time Do Not Disturb below.)

Removing Do Not Disturb

- A. Press the pre-programmed DND button.
- B. The button LED extinguishes and DND is cancelled. A flex button must be programmed for this feature to operate. Refer to flex button programming.

A. One-Time Do Not Disturb

Allows you to prevent calls from ringing at your station while you're on a call. The One-Time DND condition will automatically cancel when you end your call.

- A. Press the pre-programmed DND button while you're off-hook and connected to a CO line or intercom call. The DND button LED lights and off-hook tones at your station are cancelled.

To cancel:

- A. Replace handset. The DND button LED extinguishes and DND is cancelled. A flex button must be programmed for this feature to operate.

300.27 EXCLUSIVE HOLD

When a line is placed on Exclusive Hold, no other station in the system can retrieve this call. Hold may be programmed to be activated on the first or second depression of the Hold button. CO Lines while in a transfer hold are always placed in an Exclusive Hold condition.

300.28 EXECUTIVE OVERRIDE

Allows stations designated as "Executive" the ability to override and "bargue in" on other keysets engaged in conversation.

If you call a busy station:

- A. Dial [294]. Executive station will be bridged onto the CO line conversation in progress at the called station. Optional warning tone is heard and presented to all parties prior to cut-thru.
- B. Replace handset at Executive station to terminate the override.

NOTE: If the busy party is connected via intercom to another party, the intercom connection will be dropped when the override occurs.

NOTE: A decrease in volume may occur on the CO line after the barge-in occurs

CAUTION: USE OF THIS FEATURE WHEN THE EXECUTIVE OVERRIDE WARNING TONE IS DISABLED MAY BE INTERPRETED AS A VIOLATION OF FEDERAL OR STATE LAWS, AND AN INVASION OF PRIVACY. CONSULT COUNSEL WITH RESPECT TO APPLICABLE LAW BEFORE INTRUDING ON CALLS USING THIS FEATURE.

300.29 EXECUTIVE/SECRETARY TRANSFER

If you are designated the Executive station and your phone is busy or in DND, all calls will be routed to the Secretary station.

If you are the designated Secretary station, you can signal the Executive that is busy or in DND by using the Camp On feature.

300.30 FLASH

When connected to an outside line:

- A. Press FLASH button to disconnect outside line and reseed outside line dial tone.

300.31 FLASH ON INTERCOM

When connected to a page zone or another internal party, press FLASH button to disconnect page or intercom call. Intercom dial tone will be heard.

300.32 FLEXIBLE BUTTON ASSIGNMENT

If you have buttons on your telephone which have NOT been assigned as CO lines, Pooled group, or Loop buttons, you may program them to suit your own individual needs. There are five possible functions you may assign to these buttons:

- DSS/BLF: This button, when pressed, will automatically signal the assigned intercom station. DSS/BLF buttons are programmed by the station user.
- FEATURES: This button can be programmed so that when pressed it will activate a particu-

lar feature, thus eliminating the need for dialing the feature code. Some features require a flex button to be programmed for that feature to be accessible to the station user. Where this is the case it is so designated in this Feature Operation Section and user guide. Feature buttons are programmed by the station user. Refer to Table 300-2 for a complete listing of code/features that may be programmed onto a flexible button.

- SPEED DIAL: This button can be programmed to automatically access a speed number location for one-step operation. PBX and Centrex codes can be programmed into a speed dial bin and accessed by one button depression.
- POOLED GROUP ACCESS: A group of outside lines can be placed under one button. When this button is pressed, the system will select an available line from this group for the user to place a call on. Pool buttons are assigned in data base administration.
- LOOP: This button will act as the direct appearing button for outside lines that do not appear on the user's individual telephone. Any phone that doesn't have all lines appear on it must have a loop key. There is NO limit to the number of LOOP buttons a station may have. Loop buttons are assigned in data base administration.

Table 300-2 Button Programming Codes

100-195	Direct Station Select	80	Account Code Enter
280	Call Back (Flex Button Programming)	890-897	UCD Group Pilot Numbers 1-8
281	Pick Up	898	UCD Available/Unavailable
282	Mute (Flex Button Programming)	0	Attendant (1st Programmed Attendant)
283	Line Queue (Flex Button Programming)	*1	Internal Zone 1
284	Do Not Disturb (Flex Button Programming)	*2	Internal Zone 2
	Night Service (Attendant Station(s))	*3	Internal Zone 3
285	Camp-On (Flex Button Programming)	*4	Internal Zone 4
286	Headset Mode	*5	Internal All Call
288	Attendant Override (Flex Button Programming)	*6	External Page
294	Executive Override	*9	Meet Me Page Answer
296	CO Line Off-Net Forward (1st Programmed Attendant)	*0	All Call Page (Internal & External)
297	UCD Calls in Queue Display	[SPD]+[YY]	Speed Dial Access*
392	Personal Park		(00-19 Station) (20-99 System)
590-597	Hunt Group Pilot Numbers 1-8	[SPD]+[*]	Save Number Redial
690-697	Voice Mail Group Pilot Numbers 1-8	[SPD]+[#]	Last Number Redial
77	Background Music		
78[ZZ]	Personalized Messages	YY=	Speed Dial Bin numbers
78[00]	Clear Personalized Messages	ZZ=	Personalized Messages
78#	Personalized Message Code		
790-795	Call Park (system)		*The desired speed bin must be programmed prior to assigning the speed bin onto a flexible button.

To program flexible buttons:

- A. Press SPD button twice.
- B. Press the assigned button to be programmed (it must be programmed in data base as a multi-function button).
- C. Dial desired code (Refer to Button Programming Codes).

To erase a flexible button:

- A. Press SPD button twice.
- B. Press the button to be erase
- C. Press FLASH button.
- D. Replace handset or press ON/OFF button.

300.33 HEADSET MODE

If you wish to use a headset and have been given the ability to do so in programming.

To activate Headset Mode:

- A. Dial [286] on the dial pad or press pre-programmed FLEX button.
- B. LED will light steady.

While Headset mode is active, the ON/OFF button will activate the headset and disable speakerphone and intercom call announce operation at your station.

To de-activate Headset Mode:

- A. Dial [286] on the dial pad or press the pre-programmed FLEX button.
- B. LED will extinguish.

Refer to flex button programming.

300.34 INTERCOM CALLING

Placing an Intercom Call

- A. Press station key of party to be called (if programmed at your phone); or dial station number (100 to 195).

NOTE: Dialing a number in the numbering plan activates the telephone automatically.

- B. You will hear ringing if called station is in the "T" answering mode; or three bursts of tone if called station is in the "H" or "P" position.
- C. Lift handset or use speakerphone, after the three tone bursts stop.

- D. Hang up to end call.

Answering an Intercom Call

With your intercom signal switch in the T (center) mode, you will hear repeated bursts of intercom tone ringing and the HOLD button will slow flash.

- A. Lift handset or press ON/OFF button to answer, or move the intercom signal switch to the H (up) mode to reply. If you receive a call

from a Phone Box, you must press that DS button to answer the call.

- B. Hang up to end call.

In the P (down) mode, you will hear three bursts of tone and one-way announcement. The HOLD button will slow flash and the calling party cannot hear conversations in progress.

- A. Lift handset or press ON/OFF button to answer, or move the intercom signal switch to the H (up) mode to reply.

In the H (up) mode, you will hear three bursts of tone and an announcement. Reply handsfree or lift handset for privacy.

300.35 INTERCOM TRANSFER

Intercom transfer without DSS buttons:

- A. Receive or make an intercom call.
- B. Press the TRANS button. Intercom dial tone is heard.
- C. Dial the station where the call is to be transferred.
- D. When 2nd station answers, you are in a supervised transfer mode (1st station is staged for transfer).
- E. Hang up (station 1 and 2 are connected).

Intercom transfer using DSS buttons:

- A. Receive or make an intercom call using a DSS button.
- B. Press DSS button where call is to be transferred.
- C. Hang up (station 1 and 2 are connected).

Intercom transfer using DSS buttons with Search and Recovery:

- A. Receive or make an intercom call using a DSS button.
- B. Press DSS button to search for 2nd party.
- C. Press TRANS button to recover 1st call and abort transfer.
- D. Repeat the last two steps until second party is located.
- E. Hang up (Station 1 and 2 are connected).

300.36 LAST NUMBER REDIAL

- A. Press SPD button.
- B. Press pound [#] key.
- C. The last number dialed over an outside line will be automatically redialed.

The system will automatically select the original line used to place the call and redial the number.

If that line is busy, the system will automatically select another line from the same group and redial the number.

If no lines are available in the same group, station will receive busy tone and can queue for a line.

If the station user preselects a line before activating LNR, the preselection will override the line which was used originally.

300.37 LEAST COST ROUTING

To place an outside call when LCR has been enabled in the system:

- A. Dial [9].
- B. Dial desired telephone number (ie: 1+ area code+number) 7-digit number.
- C. Wait for answer. Lift handset or use speakerphone to converse.

If all lines available to you are busy, remain off-hook for four (4) seconds to automatically be queued onto LCR for an available line.

LCR Que Callback

If an LCR Queue Callback has been activated:

- A. When telephone is signalled, answer the call.
- B. Desired telephone number will automatically be redialed.

NOTE: Only one LCR Queue Call Back request may be initiated by a station. When a second request is made, the first request will be cancelled.

300.38 LCR QUE CANCEL

- A. Dial the LCR Queue Cancel code, [74].
- B. Replace handset or press ON/OFF button.

300.39 MEET ME PAGE

To request another party to meet you on a page:

- A. Dial the desired two-digit paging code or press programmed button.
- B. Request that party meet you on the page.
- C. Do not hang up; wait for the requested party to answer. As soon as the paged party answers and is connected to you, the page circuit is released.

Answering a Meet Me Page

- A. Go to the nearest Telephone and dial [*], [9] or press the pre-programmed flex button.
- B. You will be connected to the party that paged you.

300.40 MESSAGE WAITING

Leaving a Message Waiting Indication

Up to five messages can be left at any Station. If you dial a station that is busy, unattended, or in DND, you can leave a message waiting indication.

- A. Press the MSG WAIT button.

- B. Called party's MSG WAIT button will slow flash.

- C. Hang up.

Answering a Message Waiting Indication

If your MSG WAIT button is flashing at a slow rate, you have a message waiting for you. The first message left will be the first one called.

- A. Press flashing MSG WAIT button.
- B. Station that left message will be signaled with tone ringing.
- C. If called station does not answer, press MSG WAIT button once to leave message.

300.41 MUTE KEY

The MUTE button provides privacy during speakerphone or handset operation by disabling the microphone.

- A. Press pre-programmed MUTE button while off-hook on speakerphone or handset to activate.
- B. Press MUTE button again to deactivate.

The mute feature automatically deactivates upon call termination.

A flex button must be assigned to use this feature. Refer to flex button programming.

300.42 OFF-HOOK PREFERENCE

If your phone has been programmed for Off-Hook Preference, you will access an outside line, or a feature by going off-hook or pressing the ON/OFF button.

While Off-Hook Preference is enabled, you may access internal intercom dial tone by:

- A. Pressing your pre-programmed ICM button.
- B. LED lights steady

or

- C. Dial your own 3-digit intercom number. (Do not lift handset or press ON/OFF button before dialing intercom number.)
- D. Intercom dial tone will be heard.

You may now dial an internal station or Feature Access code.

Refer to flex button programming. Also refer to Prime Flex button programming.

300.43 PAGING

If you have been given the ability to make page announcements:

- A. Lift handset.
- B. Dial the two-digit paging code, or press programmed flex button.

*1 Internal Zone 1

- *2 Internal Zone 2
- *3 Internal Zone 3
- *4 Internal Zone 4
- *5 Internal All Call
- *6 External Zone
- *0 All Call

C. Speak in normal tone of voice to deliver message.

Stations off-hook or in DND will not hear the page announcement.

NOTE: When making a zone page or All Call page and the zone is busy, the page initiator will receive ringback tone until the zone becomes available. You will then hear a warning tone and can make the page announcement.

300.44 PBX/CENTREX TRANSFER

While connected to an outside line (PBX/Centrex):

- A. Press FLASH button.
- B. Receive transfer dial tone.
- C. Dial PBX/Centrex station number.
- D. Hang up to complete transfer.

300.45 PERSONALIZED MESSAGES

Each station can select a pre-assigned message to be displayed on the LCD of any Key Telephone calling that station.

There are ten possible messages which can be left.

- A. Dial [7][8] on the dial pad or press a programmed flex button.
- B. Dial the two-digit code for the message which will appear.
 - 00 clears messages
 - 01 VACATION
 - 02 RETURN MORNING
 - 03 RETURN AFTERNOON
 - 04 RETURN TOMORROW
 - 05 RETURN NEXT WEEK
 - 06 BUSINESS TRIP
 - 07 MEETING
 - 08 HOME
 - 09 ON BREAK
 - 10 LUNCH

NOTE: This feature is not available to the attendant(s).

300.46 PERSONALIZED MESSAGE CODE ON A FLEX KEY

You can program code 78 on a flexible key to speed access of pre-selected messages.

- A. Press SPD button twice.
- B. Press the desired flex button. LED flashes.

C. Dial [78] + #. Confirmation tone is heard.

User can now press that flex button and dial the two-digit message number 00-10 to activate or deactivate a personalized message. Confirmation tone will be heard.

300.47 PHONE BOX RINGING

To receive ringing from Phone Box(es) at a station, a DSS button must be assigned on a flex key. Refer to Flex Button Programming for instructions on how to program DSS buttons. Also refer to Sec. 610.25 for Phone Box Ring Timer.

300.48 PRIME FLEX BUTTON PROGRAMMING

If your phone is programmed for off-hook preference and have been given the ability to enable or change the prime flex button.

- A. Dial [287] on the dial pad
- B. Then dial two-digit button number.

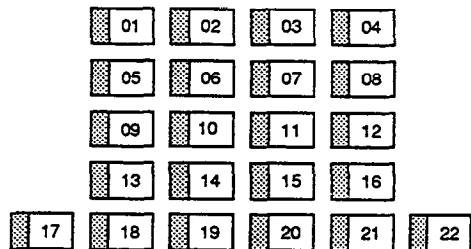

To disable Off-Hook Preference:

- A. Dial [287] on the dial pad.
- B. Dial [00] on the dial pad.

300.49 PROGRAMMING YOUR NAME INTO THE LCD DISPLAY

Every extension (key and SLT) has the capability to program the users name so that people using display telephones will see the name instead of the station number.

- A. Dial [295].
- B. Enter your name (up to 7 letters) using the pattern shown below.

Table 300-3 Entered Digits to Letters Conversion Chart

A=12	G=14	M=16	T=18
B=*2	H=*4	N=*6	U=*8
C=#2	I=#4	O=#6	V=#8
D=13	J=15	P=17	W=19
E=*3	K=*5	Q=*1	X=*9
F=#3	L=#5	R=*7	Y=#9
SPACE=##		S=#7	Z=#1

- C. Press SPD button to complete the programming process.

To erase your name:

- A. Dial [295].
- B. Press SPD button.

Station Speed Bin 00 is used to store name in display information.

300.50 PULSE TO TONE SWITCHOVER

The signaling on an outside line can be changed from dial pulse to tone (DTMF) manually while dialing out.

To perform the change-over

- A. Dial an [*]
- B. Remaining digit will be sent using DTMF.

The Pulse to Tone Switchover command may also be included into a speed dial bin. Refer to speed dial programming.

300.51 SAVE NUMBER REDIAL

If you wish to save the last number you dialed for use later:

- A. After placing an outside call, keep handset off-hook.
- B. Press SPD button twice.

To Dial a number that was saved using the steps above:

- A. Press SPD button.
- B. Dial the asterisk [*] key.

System will automatically select the original line used to place the call and redial the number.

If that line is busy, the system will automatically select another line from the same group and redial the number.

If no lines are available in the same group, station will receive busy tone and can queue for a line.

If the station user preselects a line before activating SNR, the preselection will override the line which was used originally.

300.52 PROGRAMMING PBX/CENTREX CODES ONTO A FLEX BUTTON

For easy one-button access to Centrex or PBX features, perform the following steps:

- A. Program the Centrex or PBX code into a station or system speed dial bin, including hook-flash (flash key), [*], and [#] commands. (Refer to station or system speed dial programming)

Program that speed bin onto a flex button.

Refer to flex button programming.

300.53 SPEAKERPHONE

- A. Press ON/OFF button to "ON". Intercom dial tone will be heard.

- B. Press station key of desired party, or press available outside line button and dial number. Speakerphone is activated.

- C. Press ON/OFF button to "OFF" to end call.

NOTE: For further references in this section where "lift handset" is specified, you may also use the method of pressing the "ON/OFF" button, if the telephone is programmed to be a true two-way speakerphone.

300.54 STATION SPEED DIAL

If no outside line has been specified in programming, one will be chosen automatically or you can choose one now.

- A. Press SPD button and dial bin location, or press programmed speed bin button. Station Speed numbers are 00 to 19.
- B. When called party answers, pick up handset or use speakerphone.

300.55 STORING SPEED NUMBERS

Station Speed numbers can be entered by keyset users. System Speed numbers must be entered by the first programmed attendant. If no attendant is specified, enter at Station 100.

- A. Press SPD once, then press a desired outside line key or pool key or select an outside line automatically by pressing the SPD button a second time.
- B. Dial the speed bin location. 00 to 19 for Station Speed numbers; 20 to 99 for System Speed numbers.
- C. Dial telephone number. (including special codes described below)
 - TRANS - Pressing the TRANS button during number entry initiates a Pulse-To-Tone switchover.
 - HOLD - Pressing the HOLD button during number entry inserts a Pause.
 - FLASH - Pressing the FLASH key inserts a Flash into the speed number.
 - TRANS - Pressing the TRANS button as the first entry in the speed bin inserts a no-display character causing the numbers stored in the bin not to appear on the Key Telephones display when the bin is accessed.

- D. Press SPD

- E. Hang up.

To program several speed numbers in a row, press SPD button twice to conclude programming a number and then just enter the next speed number bin to be programmed. If the station has

no line appearance for the line programmed into the speed bin, that line will come up under the Loop button or Pool button when accessed.

300.56 SYSTEM SPEED DIAL

If no outside line has been specified in programming, one will be chosen automatically or you can choose one now.

- A. Press SPD button and dial bin location, or press programmed speed bin button. System Speed numbers are 20 to 99.
- B. When called party answers, pick up handset or use speakerphone.

300.57 UNIFORM CALL DISTRIBUTION (UCD)

A. Number of Calls in Queue Display

From an idle display key telephone:

1. Dial [297] or press programmed flex button. (ON/OFF button LED lights steady)
2. Dial 3-digit UCD group number (890-897).
3. Your display will tell you how many calls are in queue for that group.
4. Dynamic update of display occurs as queue condition changes.
5. Lift the handset or press the ON/OFF button to terminate mode.

NOTE: This feature cannot be used with a call in progress and the station will be considered busy for incoming calls.

B. AVAILABLE/UNAVAILABLE MODE

If you are a UCD agent, you may place your station in the Available mode to receive UCD type of calls or you may place your station in the Unavailable mode to block UCD type calls from ringing your station.

To go Available:

1. Dial [898] on the dial pad or press pre-programmed Available/Unavailable flex button.
2. You may now receive calls.

To go Unavailable:

1. Dial [898] on the dial pad or press pre-programmed Available/Unavailable flex button.
2. You are now blocked from receiving UCD calls.

300.58 UNIVERSAL NIGHT ANSWER(UNA)

If you hear outside line ringing at another station and wish to answer it, dial [75] on the dial pad. The connected outside line can be transferred or disconnected. Each telephone utilizing Universal

Night Answer must have a loop button appearance if the ringing outside line does not appear at the phone.

300.59 VOICE MAIL OPERATION (VM)

Forward Callers to your Mail box

Intercom and Transferred CO callers may be routed directly to your mail box by forwarding your phone to a voice mail group. Callers will then be greeted by your personal voice mail greeting available (Refer to Call Forward - Voice Mail Operation)

Retrieving Voice Messages

If your Message Waiting key or programmed Voice Mail group key is flashing, you may have a voice message waiting for you. To enter the voice mail system to check for mail:

- A. Dial the Voice Mail group number or press the programmed voice mail group key or flashing Message Wait key.
- B. You will immediately be prompted to enter your password for your mail box.

Receiving a Voice Mail Message Wait

To receive a message waiting indication that a voice message has been taken for you, the Voice Mail system must be programmed to provide such an indication.

After the voice mail system receives a voice message for a station user:

- A. The voice mail must go off-hook and dial the voice mail message wait code [60].
- B. Then dial the 3-digit extension number of the station user who received a voice message.

Turning the Message Waiting Lamp Off

When a station user retrieves the voice messages from the voice mail system, the voice mail system must:

- A. Be programmed to go off-hook and dial the message cancel code [61].
- B. Then dial the 3-digit extension number of the station user who retrieved the voice message.

A. VM Tone Mode Calling Option

Allows the Voice Mail system to override a called station's H or P intercom switch settings.

When placing a call to a station and Tone ringing is desired (the Voice Mail system MUST be programmed to:

- A. Dial [5#].
- B. Then dial 3-digit station extension (call tone rings station).

300.60 VOLUME CONTROLS

There are two volume control wheels on the right side of the Key Telephone. Spinning the switch toward you decreases the volume. The front switch is for voice, background music, and speakerphone volume. The back switch is for tone ringing volume.

SINGLE LINE TELEPHONE FEATURES**300.61 ACCOUNT CODE**

SLT stations can enter an account code to identify the call or calling station.

Entering Account Code before a call:

- A. Lift the handset.
- B. Dial [80].
- C. Dial the account code. If the account code contains fewer than 12 digits, dial [*] to return to intercom dial tone. Dial tone is heard.
- D. Dial [9] or CO Access code and the desired number.

Entering Account Code during a call:

- A. Depress the hookswitch momentarily. Your call will be placed on hold while you enter your account code.
- B. Dial [80].
- C. Dial the account code. If the account code contains fewer than 12 digits, dial [*] to return automatically to the call.

300.62 CALL BACK

- A. Briefly depress and release the hookswitch.
- B. Dial [#4].
- C. Replace handset.

Only one Call Back request can be left at a station; the second request will convert to Message Waiting Request.

300.63 CALL FORWARDING

To call forward calls to another station:

- A. Lift handset.
- B. Dial [#2].
- C. Skip step c for immediate forwarding, otherwise dial the appropriate code:
 - [2] = Call Forward No Answer
 - [3] = Call Forward Busy
 - [4] = Call Forward Busy/No Answer
 - [7] = Call Forward Off-Net (via speed dial)
- D. Dial the 3-digit extension number or speed bin number where calls are to be forwarded. Confirmation tone will be heard.
- E. Replace handset.

To Remove Call Forwarding:

- A. Lift handset.
- B. Dial [#2] or [#8]. Confirmation tone will be heard.
- C. Replace the handset.

300.64 CALLING STATION TONE MODE OPTION

Allows a calling station to override a called key station's H or P intercom switch setting.

When placing a call to a key station and Tone ringing is desired:

- A. Dial [5#].
- B. Dial 3-digit station extension (call tone rings station).

300.65 CAMP-ON

After receiving intercom busy tone:

- A. Briefly depress and release the hookswitch.
- B. Dial [#*]. When the called party answers, consult with them.

While on a CO line you receive a Camp-on warning tone through handset:

- A. Choose desired call (hang up on present call and take the new one, or ignore the Camp-on signal). (also see Personal Park)

300.66 CALL PARK (System)

To place an outside call on hold and consult with, page, or call an internal party and/or transfer the outside call.

While connected to an outside line:

- A. Depress and release the hookswitch. The caller is put on Exclusive hold.
- B. Dial parking location (790 to 795). Hear confirmation tone.
- C. If you hear busy tone, depress and release the hookswitch and dial another parking location.

Retrieving a Parked Call

- A. Lift handset.
- B. Dial pound [#].
- C. Dial parking location (790 to 795) where the call was parked.

300.67 CALL TRANSFER:

Making an Unscreened Transfer

- A. Briefly depress and release the hookswitch.
- B. Dial desired intercom number.
- C. Hang up to complete the transfer.

Making a Screened Transfer:

- A. Briefly depress and release the hookswitch.
- B. Dial desired telephone number.
- C. Announce the call.
- D. Hang up to complete the transfer.

300.68 CLEAR CALL FORWARD, DND, PERSONALIZED MESSAGES

SLTs can activate and cancel call forward by dialing [#2] and DND by dialing [#1] and enable and cancel personalized messages by dialing [78xx].

A convenient code [#8] has been incorporated to cancel either Call forwarding, DND, or Personalized Messages when the SLT user has forgotten which code has been programmed on the phone.

To cancel Call Forward, DND, Personalized Messages:

- A. Lift handset. Notification tone will be heard.
- B. Dial [#8]. Confirmation tone will be heard.
- C. Replace the handset.

300.69 CO LINE QUEUING

- A. Dial outside line access code. Receive busy tone.
- B. Briefly depress and release the hookswitch.
- C. Dial [##]. Confirmation tone is heard.

300.70 CONFERENCE

You may set up a conference of 1 external and 1 other internal station.

- A. Lift handset.
- B. Make outside call.
- C. Briefly depress and release the hookswitch to put the call on hold.
- D. Dial number of internal station you wish to add.
- E. When that station answers, briefly depress and release the hookswitch again and all 3 parties will be connected.

300.71 CONFERENCE WITH PERSONAL PARK

While connected to an outside line:

- A. Depress the hookswitch momentarily. Intercom dial tone is heard.
- B. Dial [392]. (1st call is placed in personal park).
- C. Dial desired number for 2nd call.
- D. Depress the hookswitch momentarily. Intercom dial tone is heard.
- E. Dial [391]. All three parties are conferenced.

- F. Hang up to terminate conference.

300.72 DIRECT OUTSIDE LINE ACCESS

- A. Lift handset.
- B. Dial access code (9, 81 - 87).
- C. Dial desired telephone number.

300.73 DIRECTED CALL PICK-UP

Upon hearing an unattended telephone ring:

- A. Lift handset.
- B. Dial [#7].
- C. Dial station number of ringing telephone. You will be connected to intercom, incoming, recalling or transferred outside line.

300.74 DO NOT DISTURB

Activating Do Not Disturb:

- A. Lift handset.
- B. Dial [#1].
- C. Replace handset.

To cancel Do Not Disturb:

- A. Lift handset.
- B. Dial [#1] or [#8].
- C. Replace handset.

300.75 PBX/CENTREX TRANSFER (Flash Command to CO Line)

To initiate a PBX or Centrex Transfer command from an SLT.

While connected to a PBX or Centrex line:

- A. Briefly depress and release the hookswitch. Intercom dial tone will be heard.
- B. Dial [#0]. A Flash command will be presented to the PBX or Centrex line.
- C. PBX or Centrex studder tone will be heard. Dial number of desired extension.
- D. Replace handset to complete transfer.

300.76 GROUP CALL PICK-UP

Upon hearing an unattended telephone ringing:

- A. Lift the handset.
- B. Dial [#6]. You will be connected to intercom or transferred or recalling outside line call.

NOTE: You must be in the same pickup group.

300.77 PLACING CALLS ON HOLD

While connected to an outside line:

- A. Briefly press and release the hookswitch. (Call is placed on hold).

To retrieve the call:

- A. Press and release the hookswitch again.

300.78 INTERCOM CALLING

- A. Lift handset.
- B. Dial 3-digit intercom number (100-195).

300.79 LCR QUEUING (Automatic)

If all lines available to you are busy, remain off-hook for four (4) seconds to automatically be queued onto LCR for an available line.

300.80 LCR QUE CALL BACK

If an LCR Queue Call Back has been activated:

When telephone is signalled, answer the call.

Desired telephone number will automatically be redialed.

Wait for answer. Lift handset or use speakerphone to converse

NOTE: Only one LCR Queue Call Back request may be initiated by a station. When a second request is made, the first request will be cancelled.

300.81 LCR CANCEL

- A. Lift handset or press ON/OFF button.
- B. Dial the LCR Queue Cancel code, [74].
- C. Replace handset or press ON/OFF button.

300.82 MESSAGE WAITING

Leaving a Message Waiting Indication

- A. Lift handset.
- B. Dial intercom station. Receive no answer, or DND tone.
- C. Briefly depress and release the hookswitch.
- D. Dial [#4].
- E. Replace handset.

Answering a Message Waiting Indication.

Your message waiting lamp is flashing:

- A. Lift handset.
- B. Dial [#5]. Station that left the message will ring.

Only SLTs equipped with message waiting lamp will have access to this feature.

300.83 OFF-HOOK PREFERENCE

If your phone has been programmed for Off-Hook Preference, you will hear outside line dial tone when lifting the handset.

When this operation is desired, you may not have access to all features contained in this User Guide. However, consult your Centrex or PBX User's Guide for additional features you may have.

300.84 PERSONALIZED MESSAGES

Each station can select a pre-assigned message to be displayed on the LCD of any Key Telephone calling that station. To select one of the ten available messages:

- A. Dial[78] on the dial pad.
- B. Dial the two-digit code for the message which will appear.
- C. Hang up. (Activating DND cancels selected message.)

300.85 PAGING

- A. Lift handset.
- B. Dial the two-digit paging code. Wait for page warning tone
 - *1 Internal Zone 1
 - *2 Internal Zone 2
 - *3 Internal Zone 3
 - *4 Internal Zone 4
 - *5 Internal All Call
 - *6 External Zone
 - *0 All Call
- C. Speak in normal tone of voice to deliver message.

Stations off-hook or in DND will not hear the page announcement.

NOTE: When making a zone page or All Call page and the zone is busy, the page initiator will receive ringback tone until the zone becomes available. You will then hear a warning tone and can make the page announcement.

- D. Deliver page in normal tone of voice.
- E. Replace handset to terminate page.

300.86 PERSONAL PARK (Flip-Flop)

While connected to first call:

- A. Depress the hookswitch momentarily. Intercom dial tone is heard.
- B. Dial [392]. (call is placed in personal park).
- C. Dial desired number for 2nd call.
- D. Depress the hookswitch momentarily. Intercom dial tone is heard.
- E. Dial [392]. (1st call is returned and 2nd call is placed in personal park).

The user can alternately connect to the other call by doing a hook flash and dialing [392] as many times as necessary.

300.87 PROGRAMMING YOUR NAME INTO THE LCD DISPLAY

Every SLT extension has the capability to program the users name so that people using display telephones will see the name instead of the station number.

- A. Lift handset.
- B. Dial [295].
- C. Enter your name (up to 7 letters) using the pattern shown below.

Table 300-4 Entered Digits to Letters Conversion Chart

A=12	G=14	M=16	T=18
B=*2	H=*4	N=*6	U=*8
C=#2	I=#4	O=#6	V=#8
D=13	J=15	P=17	W=19
E=*3	K=*5	Q=*1	X=*9
F=#3	L=#5	R=*7	Y=#9
SPACE=##		S=#7	Z=#1

- D. Press the hookswitch to complete the programming process.

Station Speed Bin 00 is used to store name in display information.

300.88 STATION SPEED DIAL

- A. Lift handset.
- B. Dial [#9].
- C. Dial desired station speed bin number (00-19).

300.89 STORING STATION SPEED NUMBERS

- A. Lift handset.
- B. Dial [#3].
- C. Dial desired station speed bin number (00-19).
- D. Dial telephone number you wish to store.
- E. Briefly depress and release the hookswitch. (Confirmation tone is heard.)

Line Group 1 will be programmed along with SLT speed numbers and thus Line Group 1 will be used when activating speed dial from an SLT.

300.90 SYSTEM SPEED DIAL

- A. Lift handset.
- B. Dial [#9].
- C. Dial desired system speed bin number (20-99).

300.91 UNIVERSAL NIGHT ANSWER (UNA)

Upon hearing an incoming signal:

- A. Lift handset.
- B. Dial UNA access code [75]. You will be connected to ringing outside line.

300.92 UCD AVAILABLE/UNAVAILABLE

If you are a UCD Agent, you may place your station in the Available mode to receive UCD type of calls or you may place your station in the Unavailable mode to block UCD type of calls from ringing at your station.

To go Available:

- A. Dial [898] on the dial pad. You may now receive calls.

To go Unavailable:

- A. Dial [898] on the dial pad. You are now blocked from receiving UCD calls.

ATTENDANT FEATURES**300.93 ANSWERING AN OUTSIDE CALL**

- A. Lift handset.
- B. Press slow flashing outside line button. (If your telephone is programmed with Preferred Line Answer, you may answer an outside line by lifting the handset.)

300.94 PLACING OUTSIDE LINE ON HOLD

- A. If your system is programmed for Exclusive Hold Preference, press HOLD button once for Exclusive Hold and twice for System Hold.
- B. If your system is programmed for System Hold Preference, press HOLD button once for System Hold and twice for Exclusive Hold.

300.95 ANSWERING A RECALLING OUTSIDE LINE

When an outside line has remained on hold for an extended period of time, you will be reminded with a recalling ring.

- A. Press outside line button flashing at very fast rate.
- B. Lift handset to converse.

300.96 ATTENDANT ACTIVATION OF BGM AT A PHONE BOX

The Attendant may control (turn ON and OFF) background music at a phone box station.

To control background music at a specific phone box:

- A. Dial [289] on the dial pad.
- B. Then dial the three-digit station number of the desired phone box.

Then dial either:

- [0] to turn BGM off
- or
- [1] to turn BGM on

300.97 ATTENDANT DISABLE OUTGOING ACCESS

The attendant station can disable CO lines, preventing outgoing CO calls.

- A. Lift handset or press ON/OFF button.
- B. Dial [298]. Confirmation tone is heard.
- C. Depress the line button(s) of the CO Line(s) to be disabled. Confirmation tone is heard and the CO Line Button(s) LED is flashing.
- D. To re-activate the CO Line(s), repeat the steps followed to disable it.

300.98 ATTENDANT OVERRIDE

If Attendant Override is allowed, Attendant(s) stations may override or call stations that are either busy or in Do Not Disturb.

If the Attendant calls a station that is busy on a CO call and wishes to alert them of a waiting call:

- A. Press the pre-programmed ATTN OVERRIDE button. Three short tone bursts will be presented to the called party.
- B. After five (5) seconds, the station's CO line will automatically be placed on hold and the Attendant will be cut-thru.

If the Attendant calls a station that is in Do Not Disturb mode and wishes to alert them of a call;

- A. Press the pre-programmed ATTN OVERRIDE button. The station will be signalled with a Camp-on tone.

300.99 ATTENDANT RECALL

When an outside line has remained on hold for an extended period of time, you will be reminded with a recalling ring.

- A. Press outside line button flashing at a very fast rate.
- B. Lift handset to converse.

300.100 EXECUTIVE OVERRIDE

Allows stations designated as "Executive" the ability to override and "barge in" on other keysets engaged in conversation.

If you call a busy station:

- A. Dial [294]. Executive station will be bridged onto the CO conversation in progress at the called station. Optional warning tone is heard and presented to all parties prior to cut-thru.

- B. Replace handset at Executive station to terminate the override.

NOTE: If the busy party is connected via intercom to another party, the intercom connection will be dropped when the override occurs.

NOTE: A decrease in volume may occur on the CO line after the barge-in occurs.

CAUTION: USE OF THIS FEATURE WHEN THE EXECUTIVE OVERRIDE WARNING TONE IS DISABLED MAY BE INTERPRETED AS A VIOLATION OF FEDERAL OR STATE LAWS, AND AN INVASION OF PRIVACY. CONSULT COUNSEL WITH RESPECT TO APPLICABLE LAW BEFORE INTRUDING ON CALLS USING THIS FEATURE.

300.101 INTERCOM CALLING

Placing an Intercom Call

- A. Press station key of party to be called (if programmed at your phone); or dial station number (100 to 195).
- B. You will hear ringing if called station is in the "T" answering mode; or three bursts of tone if called station is in the "H" or "P" position.
- C. Lift handset or use speaker-phone, tone bursts stop.
- D. Hang up to end call.

Answering an Intercom Call

With your intercom signal switch in the T mode, you will hear repeated bursts of intercom tone ringing and the HOLD button will slow flash.

- A. Lift handset or press ON/OFF button to answer. If you receive a call from a Phone Box, you must press that DSS button to answer the call.
- B. Hang up to end call.

In the P mode, you will hear three bursts of tone and one-way announcement. The HOLD button will slow flash and the calling party cannot hear conversations in progress.

In the H mode, you will hear three bursts of tone and an announcement. Reply handsfree or lift handset for privacy.

300.102 INCOMING CO LINES OFF-NET (via speed dial)

Allows the first attendant station to forward incoming CO calls to an off-net location.

In a speed dial bin, store the number of the off-net location where calls are to be forwarded. Follow instructions provided for storing station or system speed dial numbers.

- A. Dial [296] on the dial pad or press pre-programmed CO Off-Net Forward button.

- B. Dial the CO group access code of the group to be forwarded.

81=CO Group 1
 82=CO Group 2
 83=CO Group 3
 84=CO Group 4
 85=CO Group 5
 86=CO Group 6
 87=CO Group 7
 88=All CO Lines

- C. Dial the speed bin number that contains the number where calls are to be forwarded or press the programmed button for the speed bin. Confirmation tone is heard.

Canceling Off-Net Forwarding

- A. Dial [296] on the dial pad or press pre-programmed CO Off-Net Forward button.
 B. Dial the CO group access code.
 C. Dial [#]. Confirmation tone is heard.

300.103 NIGHT SERVICE

- A. Any designated attendant can place the system into Night Service by pressing the pre-programmed Night Service button (DND).
 B. Pressing the pre-programmed Night Service button again removes the system from Night Service.

300.104 SETTING SYSTEM TIME AND DATE

Must be set by the first programmed attendant.

- A. Dial [76] on the dial pad. Confirmation tone is heard.
 B. Enter date and time as follows:
 YYMMDDHHMM
 YY = year 00-99
 MM = month 01-12
 DD = day 01-31
 HH = hour 00-23
 MM=minute 00-59

When the correct number of digits are entered, confirmation tone will be heard and the display will update.

300.105 STORING SYSTEM SPEED NUMBERS

System Speed numbers must be entered by the first programmed attendant. If no attendant is specified, enter at Station 100.

- A. Press SPD once, then press a desired outside line key or select an outside line automatically by pressing the SPEED CALL button a second time.

- B. Dial the System speed bin location (20 to 99).
 C. Dial telephone number.
 D. Press SPD.
 E. Hang up.

— Pressing the TRANS button during number entry initiates a Pulse-To-Tone switchover. Pressing the HOLD button during number entry inserts a Pause. Pressing the FLASH key inserts a Flash into the speed number.

— Pressing the TRANS button as the first entry in the speed bin inserts a no-display character causing the numbers stored in the bin not to appear on the Key Telephones display when the bin is accessed.

Speed Bin numbers 60-99 are NOT monitored by Toll Restriction.

ATTENDANT with DSS/DLS FEATURES

The attendant console may be programmed in one of five different ways. Therefore, you may not have all of the features listed below on your console. Refer to Sec. 200.150 for a description of each map.

300.106 ATTENDANT TRANSFER SEARCH

When attempting to locate a party:

- A. Press a station button to signal that station. If the party is not located, press another station button to continue the search.

300.107 PLACING AN OUTSIDE CALL (Automatic Line Selection)

- A. Press outside line button. ON/OFF button LED will light and dial tone will be heard.
 B. Dial desired party.
 C. When called party answers, lift handset to converse or use speakerphone

300.108 CALL PARK

While connected to an outside line:

- A. Press programmed CALL PARK button. The caller is put on Exclusive hold.
 B. At this time, you can page or call another internal station.
 C. When the party you called responds, announce the call park location and replace handset.

300.109 DO NOT DISTURB INDICATION

The associated station button will flash at a medium rate to indicate that station is in Do Not Disturb.

300.110 RETRIEVING A PARKED CALL

- A. Lift handset or press ON/OFF button.
- B. Dial [#].
- C. Dial parking location (790 to 795) where the call was parked.

300.111 CALL TRANSFER

Outside lines can be transferred from one phone to another within the system. The transfer can be either screened (announced) or unscreened to either an idle or busy station.

Screened Transfer

- A. While connected to an outside line, press station button where call is to be transferred (if programmed on your telephone), or press TRANS button and dial station number (100 to 195).
- B. The called extension signals according to the intercom signal switch position.
- C. When that extension answers, announce the transfer.
- D. Hang up to complete transfer.

Unscreened Transfer

When the called extension begins to signal, hang up to transfer the call (Recall timer starts).

Transfer Search

- A. When attempting to locate a party, press a station key to signal a station.
- B. If the party is not located, press another station key to continue the search, or press the TRAN button and dial the station number.
- C. If the party is not located, press the TRANS button again and dial another station number to continue the search.
- D. When the called party answers, hang up to complete the transfer.

300.112 CAMP-ON

While connected to an outside line:

- A. Press desired station button.
- B. When busy tone is heard, press CAMP-ON button.
- C. Replace handset, access another CO Line or press RELEASE button (if you have one).

300.113 Flexible Button Programming

- A. Press SPD button twice.
- B. Press FLEX button to be programmed (it must be programmed in data base as a flexible button).
- C. Dial desired code (Refer to Table 300-2 Button Programming Codes).

300.114 MEET ME PAGE

To request another party meet you on a page:

- A. Dial the desired two-digit paging code or press programmed button.
- B. Request that party meet you on the page.
- C. Do not hang up; wait for the requested party to answer.

Answering a Meet Me Page

- D. Go to the nearest Telephone and dial [*9].
- E. You will be connected to the party that paged you.

300.115 PAGING**A. External Paging**

- A. Press programmed PAGE button or dial [*6].
- B. Speak in normal tone of voice to deliver message.
- C. Replace handset to terminate page announcement.

B. Internal Paging

Stations off-hook or in DND will not receive the page announcement.

- A. Press programmed PAGE button or dial one of the following codes:
 - B. *1 Internal Zone 1
 - *2 Internal Zone 2
 - *3 Internal Zone 3
 - *4 Internal Zone 4
 - *5 Internal All Call
 - C. Speak in normal tone of voice to deliver message.
 - D. Replace handset to terminate page announcement.
- C. All Call Paging (Internal/External)**
- A. Press programmed PAGE button or dial [*0].
 - B. Speak in normal tone of voice to deliver message.
 - C. Replace handset to terminate page announcement.

300.116 RELEASE BUTTON

DSS/DLS maps 1 and 3 contain a Release button that may be pressed to disconnect or terminate an intercom call, transfer sequence, page announcement or CO call.

Table 310-1 96EX LCD Displays

310.1 LCD Displays

The display is arranged into an upper and lower field. The upper field displays the current activity of the telephone. The lower field is divided into two sections. The left section of the lower field displays the date, speed bin number, connected intercom

station or outside line number. The right section of the lower field displays the current time or elapsed time on an outside call. The following Table shows what will appear on the LCD displays based on the function performed.

FUNCTION	CALLING STATION'S DISPLAY	CALLED STATION'S DISPLAY
Idle Station	<div style="border: 1px solid black; padding: 5px; text-align: center;"> STATION 100 MM/DD/YY HH:MM am </div>	
Manually Dialing Outgoing Calls	<div style="border: 1px solid black; padding: 5px; text-align: center;"> 18005551212 LINE 16 HH:MM am </div>	
Recalling Line from Hold	<div style="border: 1px solid black; padding: 5px; text-align: center;"> LINE 16 RECALLING MM/DD/YY HH:MM am </div>	
Recalling Line from Another Station	<div style="border: 1px solid black; padding: 5px; text-align: center;"> RECALL FROM STA 101 LINE 16 HH:MM am </div> <div style="border: 1px solid black; padding: 5px; text-align: center; margin-top: 5px;"> RECALL FROM ..(name).. LINE 16 HH:MM am </div>	
Connected to an Incoming CO Line		<div style="border: 1px solid black; padding: 5px; text-align: center;"> STATION 100 LINE 16 00:00:10 </div>
Intercom Call	<div style="border: 1px solid black; padding: 5px; text-align: center;"> CALL TO STA 101 MM/DD/YY HH:MM am </div> <div style="border: 1px solid black; padding: 5px; text-align: center; margin-top: 5px;"> CALL TO ..(name).. MM/DD/YY HH:MM am </div>	<div style="border: 1px solid black; padding: 5px; text-align: center;"> CALL FROM STA 100 MM/DD/YY HH:MM am </div> <div style="border: 1px solid black; padding: 5px; text-align: center; margin-top: 5px;"> CALL FROM ..(name).. MM/DD/YY HH:MM am </div>

Table 310-1 96EX LCD Displays (Cont'd)

FUNCTION	CALLING STATION'S DISPLAY	CALLED STATION'S DISPLAY
Camp-on	<div data-bbox="526 570 943 693" style="border: 1px solid black; padding: 5px; text-align: center;"> CALL TO ..(name).. MM/DD/YY HH:MM am </div>	<div data-bbox="1012 427 1428 551" style="border: 1px solid black; padding: 5px; text-align: center;"> CAMP-ON BY STA 100 MM/DD/YY HH:MM am </div> <div data-bbox="1012 570 1428 693" style="border: 1px solid black; padding: 5px; text-align: center;"> CAMP-ON BY ..(name).. MM/DD/YY HH:MM am </div>
Conference	<div data-bbox="526 746 943 870" style="border: 1px solid black; padding: 5px; text-align: center;"> CONFERENCE MM/DD/YY HH:MM am </div>	<div data-bbox="1012 746 1428 870" style="border: 1px solid black; padding: 5px; text-align: center;"> CONFERENCE MM/DD/YY HH:MM am </div>
Internal Page	<div data-bbox="526 995 943 1119" style="border: 1px solid black; padding: 5px; text-align: center;"> INTERNAL PAGE ZONE 1 HH:MM am </div>	<div data-bbox="1012 923 1428 1046" style="border: 1px solid black; padding: 5px; text-align: center;"> PAGE FROM STA 100 MM/DD/YY HH:MM am </div> <div data-bbox="1012 1066 1428 1189" style="border: 1px solid black; padding: 5px; text-align: center;"> PAGE FROM ..(name).. MM/DD/YY HH:MM am </div>
External Page	<div data-bbox="526 1242 943 1366" style="border: 1px solid black; padding: 5px; text-align: center;"> EXTERNAL PAGE ZONE 1 HH:MM am </div>	
All Call Page	<div data-bbox="526 1432 943 1555" style="border: 1px solid black; padding: 5px; text-align: center;"> ALL CALL PAGE MM/DD/YY HH:MM am </div>	<div data-bbox="1012 1432 1428 1555" style="border: 1px solid black; padding: 5px; text-align: center;"> PAGE FROM STA 102 MM/DD/YY HH:MM am </div>
Meet Me Page	<div data-bbox="526 1596 943 1719" style="border: 1px solid black; padding: 5px; text-align: center;"> ALL CALL MM/DD/YY HH:MM am </div> <div data-bbox="526 1738 943 1862" style="border: 1px solid black; padding: 5px; text-align: center;"> CALL TO 105 MM/DD/YY HH:MM am </div>	<div data-bbox="1012 1596 1428 1719" style="border: 1px solid black; padding: 5px; text-align: center;"> PAGE FROM 100 MM/DD/YY HH:MM am </div> <div data-bbox="1012 1738 1428 1862" style="border: 1px solid black; padding: 5px; text-align: center;"> CALL FROM 100 MM/DD/YY HH:MM am </div>

Table 310-1 96EX LCD Displays (Cont'd)

FUNCTION	CALLING STATION'S DISPLAY	CALLED STATION'S DISPLAY
<p>Station Call Forward (Originating Station) (Name in Display)</p>	<div data-bbox="566 442 976 555" style="border: 1px solid black; padding: 5px; margin-bottom: 10px;"> <p>FORWARDED TO STA XXX MM/DD/YY HH:MM am</p> </div> <div data-bbox="566 583 976 695" style="border: 1px solid black; padding: 5px;"> <p>FORWARDED TO ..(name).. MM/DD/YY HH:MM am</p> </div>	
<p>Station No-Answer Call Forward (Originating Station)</p>	<div data-bbox="566 763 976 876" style="border: 1px solid black; padding: 5px; margin-bottom: 10px;"> <p>NO ANS FWD TO STA XXX MM/DD/YY HH:MM am</p> </div> <div data-bbox="566 904 976 1017" style="border: 1px solid black; padding: 5px;"> <p>NO ANS FWD TO ..(name).. MM/DD/YY HH:MM am</p> </div>	
<p>Station Busy/No-Answer Call Forward (Originating Station)</p>	<div data-bbox="566 1087 976 1200" style="border: 1px solid black; padding: 5px; margin-bottom: 10px;"> <p>BSY/NA FWD TO STA XXX MM/DD/YY HH:MM am</p> </div> <div data-bbox="566 1227 976 1340" style="border: 1px solid black; padding: 5px;"> <p>BSY/NA FWD TO ..(name).. MM/DD/YY HH:MM am</p> </div>	
<p>Station Busy Call Forward (Originating Station)</p>	<div data-bbox="566 1410 976 1523" style="border: 1px solid black; padding: 5px; margin-bottom: 10px;"> <p>BUSY FWD TO STA XXX MM/DD/YY HH:MM am</p> </div> <div data-bbox="566 1551 976 1664" style="border: 1px solid black; padding: 5px;"> <p>BUSY FWD TO ..(name).. MM/DD/YY HH:MM am</p> </div>	
<p>Forwarded Call (Name in Display)</p>	<div data-bbox="566 1734 976 1847" style="border: 1px solid black; padding: 5px; margin-bottom: 10px;"> <p>FORWARDED TO STA XXX CALLED XXX HH:MM am</p> </div> <div data-bbox="566 1874 976 1987" style="border: 1px solid black; padding: 5px;"> <p>FORWARDED TO ..(name).. CALLED XXX HH:MM am</p> </div>	<div data-bbox="1045 1734 1455 1847" style="border: 1px solid black; padding: 5px; margin-bottom: 10px;"> <p>CALL FROM STA XXX VIA STA XXX HH:MM am</p> </div> <div data-bbox="1045 1874 1455 1987" style="border: 1px solid black; padding: 5px;"> <p>CALL FROM ..(name).. VIA STA XXX HH:MM am</p> </div>

Table 310-1 96EX LCD Displays (Cont'd)

FUNCTION	CALLING STATION'S DISPLAY	CALLED STATION'S DISPLAY
Forwarded Call (before and after call is answered)	<div data-bbox="540 417 948 527" style="border: 1px solid black; padding: 5px; margin-bottom: 5px;">FORWARDED TO STA 101 CALLED 110 HH:MM am</div> <div data-bbox="540 555 948 666" style="border: 1px solid black; padding: 5px;">CALL TO STA 101 MM/DD/YY HH:MM am</div>	<div data-bbox="1021 417 1429 527" style="border: 1px solid black; padding: 5px; margin-bottom: 5px;">CALL FROM STA 100 VIA STA 110 HH:MM am</div> <div data-bbox="1021 555 1429 666" style="border: 1px solid black; padding: 5px;">CALL FROM STA 100 MM/DD/YY HH:MM am</div>
Station Forwarding to a Voice Mail Group (Station Idle)	<div data-bbox="540 736 948 846" style="border: 1px solid black; padding: 5px;">FORWARDED TO VOICE MAIL MM/DD/YY HH:MM am</div>	
Station Forwarding to a UCD Group (Station Idle)	<div data-bbox="540 910 948 1021" style="border: 1px solid black; padding: 5px;">FORWARDED TO UCD 1 MM/DD/YY HH:MM am</div>	
Preset Forward		<div data-bbox="1021 1085 1429 1195" style="border: 1px solid black; padding: 5px;">FORWARD RING FROM STA 100 LINE 16 HH:MM am</div>
Station calling a Station Forwarded to a Voice Mail Group	<div data-bbox="540 1259 948 1370" style="border: 1px solid black; padding: 5px;">FORWARDED TO VOICE MAIL VIA STA 110 HH:MM am</div>	<div data-bbox="1021 1259 1429 1370" style="border: 1px solid black; padding: 5px;">FORWARDED TO VOICE MAIL MM/DD/YY HH:MM am</div>
Call Pickup	<div data-bbox="540 1506 948 1617" style="border: 1px solid black; padding: 5px;">CALL TO STA 100 PICKED UP BY STA 110 HH:MM am</div>	<div data-bbox="1021 1434 1429 1544" style="border: 1px solid black; padding: 5px; margin-bottom: 5px;">CALL TO STA 100 FROM STA 112 HH:MM am</div> <div data-bbox="1021 1581 1429 1691" style="border: 1px solid black; padding: 5px;">XSFR TO STA 100 PICKED UP LINE 16 HH:MM am</div>
Exclusive Hold	<div data-bbox="540 1753 948 1864" style="border: 1px solid black; padding: 5px;">LINE HOLDING LINE 16 HH:MM am</div>	

Table 310-1 96EX LCD Displays (Cont'd)

FUNCTION	CALLING STATION'S DISPLAY	CALLED STATION'S DISPLAY
Do Not Disturb	<div data-bbox="602 436 1015 542" style="border: 1px solid black; padding: 5px; margin-bottom: 10px;"> DO NOT DISTURB STA 110 MM/DD/YY HH:MM am </div> <div data-bbox="602 574 1015 680" style="border: 1px solid black; padding: 5px;"> DO NOT DISTURB ..(name).. MM/DD/YY HH:MM am </div>	<div data-bbox="1082 510 1495 617" style="border: 1px solid black; padding: 5px;"> STATION IN DO NOT DISTURB MM/DD/YY HH:MM am </div>
Call Back	<div data-bbox="602 755 1015 861" style="border: 1px solid black; padding: 5px; margin-bottom: 10px;"> CALL BACK FROM STA 100 MM/DD/YY HH:MM am </div> <div data-bbox="602 893 1015 1000" style="border: 1px solid black; padding: 5px;"> CALL BACK FROM ..(name).. MM/DD/YY HH:MM am </div>	<div data-bbox="1082 755 1495 861" style="border: 1px solid black; padding: 5px; margin-bottom: 10px;"> CALL FROM STA 114 MM/DD/YY HH:MM am </div> <div data-bbox="1082 893 1495 1000" style="border: 1px solid black; padding: 5px;"> CALL FROM ..(name).. MM/DD/YY HH:MM am </div>
Outside Line Transfer		<div data-bbox="1082 1074 1495 1181" style="border: 1px solid black; padding: 5px; margin-bottom: 10px;"> TRANSFER FROM STA 100 LINE 16 HH:MM am </div> <div data-bbox="1082 1212 1495 1319" style="border: 1px solid black; padding: 5px;"> TRANSFER FROM ..(name).. LINE 16 HH:MM am </div>
Message Waiting		<div data-bbox="1082 1393 1495 1500" style="border: 1px solid black; padding: 5px;"> MSG: 102 115 103 112 104 MM/DD/YY HH:MM am </div>
Reply to a Message Waiting	<div data-bbox="602 1638 1015 1744" style="border: 1px solid black; padding: 5px; margin-bottom: 10px;"> CALL TO STA 101 MM/DD/YY HH:MM am </div> <div data-bbox="602 1776 1015 1883" style="border: 1px solid black; padding: 5px;"> CALL TO ..(name).. MM/DD/YY HH:MM am </div>	<div data-bbox="1082 1574 1495 1681" style="border: 1px solid black; padding: 5px; margin-bottom: 10px;"> CALL FROM ..(name).. MM/DD/YY HH:MM am </div> <div data-bbox="1082 1713 1495 1819" style="border: 1px solid black; padding: 5px; margin-bottom: 10px;"> CALL FROM STA 100 MM/DD/YY HH:MM am </div> <div data-bbox="1082 1851 1495 1957" style="border: 1px solid black; padding: 5px;"> CALL BACK FROM STA 100 MM/DD/YY HH:MM am </div>

Table 310-1 96EX LCD Displays (Cont'd)

FUNCTION	CALLING STATION'S DISPLAY	CALLED STATION'S DISPLAY
Programmed Flash Command (F)	<div style="border: 1px solid black; padding: 5px; width: fit-content; margin: auto;">F*12</div>	
Programmed Pause Command (P)	<div style="border: 1px solid black; padding: 5px; width: fit-content; margin: auto;">950777P1234567 SPEED 10 HH:MM am</div>	
Programmed Pulse-To-Tone Switchover (S)	<div style="border: 1px solid black; padding: 5px; width: fit-content; margin: auto;">950777S1234567 SPEED 10 HH:MM am</div>	
CO Line Queuing	<div style="border: 1px solid black; padding: 5px; width: fit-content; margin: auto; text-align: center;">PLACED IN QUEUE FOR LINE 16 HH:MM am</div> <div style="border: 1px solid black; padding: 5px; width: fit-content; margin: auto; text-align: center; margin-top: 10px;">QUEUE CALL BACK LINE 16 HH:MM am</div>	
Hunt Groups	<div style="border: 1px solid black; padding: 5px; width: fit-content; margin: auto; text-align: center;">CALL TO STA 100 VIA HUNT HH:MM am</div> <div style="border: 1px solid black; padding: 5px; width: fit-content; margin: auto; text-align: center; margin-top: 10px;">CALL TO ..(name).. VIA HUNT HH:MM am</div>	
UCD Groups	<div style="border: 1px solid black; padding: 5px; width: fit-content; margin: auto; text-align: center;">CALL TO STA 100 VIA UCD HH:MM am</div> <div style="border: 1px solid black; padding: 5px; width: fit-content; margin: auto; text-align: center; margin-top: 10px;">CALL TO ..(name).. VIA UCD HH:MM am</div>	

Table 310-1 96EX LCD Displays (Cont'd)

FUNCTION	CALLING STATION'S DISPLAY	CALLED STATION'S DISPLAY
Ringing CO Lines		<div style="border: 1px solid black; padding: 5px; text-align: center;"> LINE RINGING LINE 16 HH:MM am </div>
Display Security Feature	<div style="border: 1px solid black; padding: 5px; text-align: center;"> DISPLAY SECURITY MM/DD/YY HH:MM am </div>	
Station Forwarding Off-Net	<div style="border: 1px solid black; padding: 5px; text-align: center;"> FORWARDED TO SPEED 02 MM/DD/YY HH:MM am </div>	
Calling a Station Forwarded Off-Net	<div style="border: 1px solid black; padding: 5px; text-align: center;"> FORWARDED OFF NET LINE 08 CALLED 102 </div>	<div style="border: 1px solid black; padding: 5px; text-align: center;"> FORWARDED TO SPEED 02 MM/DD/YY HH:MM am </div>
Calls in Queue (Agents and Overflow Stations)	<div style="border: 1px solid black; padding: 5px; text-align: center;"> 01 CALLS IN QUEUE MM/DD/YY HH:MM am </div>	
Calls in Queue (using Dial Code)	<div style="border: 1px solid black; padding: 5px; text-align: center;"> UCD 1 02 CALLS IN QUEUE MM/DD/YY HH:MM am </div>	
Unavailable Mode (Agent Station)	<div style="border: 1px solid black; padding: 5px; text-align: center;"> UNAVAILABLE UCD * XXX * MM/DD/YY HH:MM am </div>	
Station calling a Voice Mail Group Pilot Number	<div style="border: 1px solid black; padding: 5px; text-align: center;"> CALL TO VOICE MAIL MM/DD/YY HH:MM am </div>	

SECTION 400

GENERAL DESCRIPTION

400.1 SYSTEM TECHNOLOGY

The Starplus 96EX Hybrid Key Telephone System is an expandable modular system engineered for growth through modular card (PCB) expansion as well as KSU module expansion and provides a flexible assortment of features through software options and optional circuit cards. Figure 200-1 is a block diagram of the System.

The Starplus 96EX Hybrid Key Telephone System is the upper end of a family of Electronic Key Telephone Systems designed to meet the needs of telephone users from small to large. The other members of this family are the Starplus 308EX, 616EX, and Starplus 616 FLEX Key Telephone System (flat pack), the 1224 Key Telephone System (flat pack) and the 2448EX Hybrid Key Telephone System (modular PCB).

The Starplus 96EX Hybrid Key Telephone System is a modular system designed for growth using state of the art Digital Technology for switching control, command processing and also utilizes a CMOS based microprocessor controlled cross point switching matrix, and provides a flexible assortment of features.

This family of systems is engineered to allow the same telephones to migrate through the complete product line.

This system has a capacity of up to 40 outside lines, 96 internal telephone stations, and 14 intercom channels. The system architecture allows for non-blocking access to all 40 CO lines. The KSU is designed as two cabinets. The Basic cabinet will support 24 outside lines and 48 internal stations. The Expansion cabinet will support an additional 16 outside lines and 48 internal stations. Standard single-line (2500 type) telephones can be installed in the system by exchanging key telephone boards for single-line boards.

400.2 COMMON EQUIPMENT

The following components are necessary to operate the Starplus 96EX Hybrid Key Telephone System: (Refer to Appendix B for a complete 96EX component list with Part #'s)

- Basic KSU
- Central Processor Board (CPB) with generic software
- DC/DC Converter (DC/DC)
- Key Station Interface Board (KIB)

- Central Office Interface Board (COB)
- Power Supply (PS)
- External Power Housing (EPH2)
- Enhanced Key Telephone or
- Executive Key Telephone

A. Basic Key Service Unit (BKSU)

The Basic KSU is housed in a wall-mount cabinet that contains card slots for modular boards and associated pre-wired connectors. The KSU provides card slot positions for DC/DC Converter (DC/DC), Central Processing Board (CPB), 24 CO/PBX lines (3 COB's), 48 stations (6 KIB's), an Application Board (APL), and two Power Failure Transfer units. One (1) BKSU is required per system.

B. Expansion Key Service Unit (EKSU)

The Expansion KSU is an add-on cabinet that mounts next to the Basic KSU with ribbon cable connectors to interface to the Basic KSU, card slots to support up to 8 PCB's and a pre-wired CO line interface connector (P2). The Expansion KSU will support a configuration of 16 CO lines and 48 Key Telephones/DSS Units/Phone Boxes. One (1) EKSU is required when the system exceeds 24 CO lines or 48 stations. Two power supplies are required in the External Power Supply Housing (EPH2) for Expansion KSU operation.

C. External Power Supply Housing 2 (EPH2)

The External Power Supply Housing (EPH2) is a wall mountable cabinet that houses the EPS motherboard (backplane), two Power Supply Units (PS), the Single Line Ringing Generator and Message Waiting Power Supply Unit (RG), and the Battery Charging Unit (BC). The EPH2 contains an ON/OFF power switch, an AC input cord, a DC output cord, battery connector panel for connecting 24V dc of battery power, an AC ON LED, a DC ON LED and a RING ON LED for the Battery Charging Board (BC). One (1) EPH2 is required per system.

The Power Supply Units (PS), Ring Generator Unit (RG) and the Battery Charging Unit (BC) all incorporate modular connectors that interface on the EPH2 motherboard allowing easy installation and removal of these units.

Figure 400-1 Starplus 96EX System Block Diagram

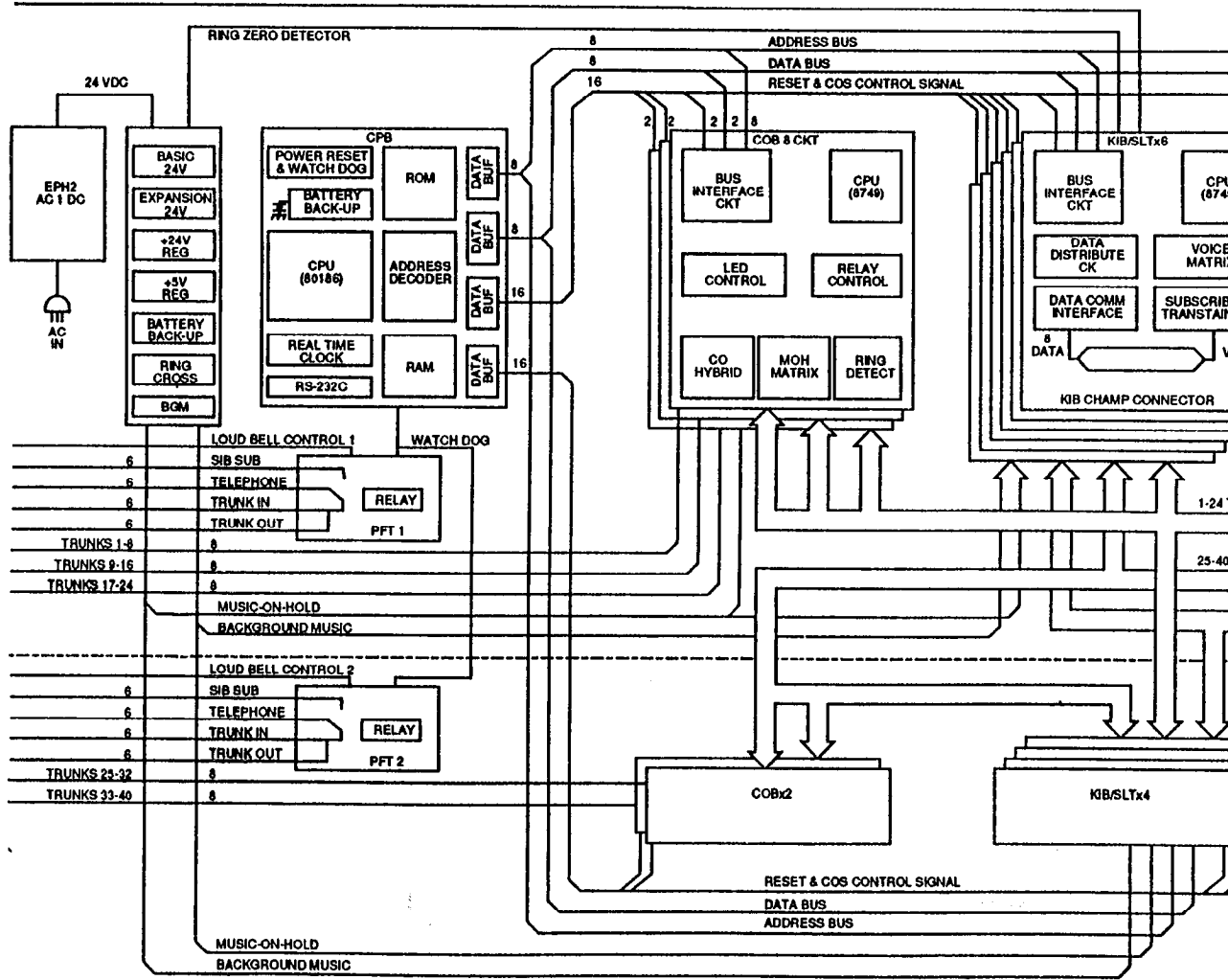

D. Power Supply Unit (PS)

This unit converts 117V ac to 24 volt power required for system operation. One power supply is required for the Basic KSU and an additional power supply is required for the Expansion KSU. Both units plug into the External Power Supply Housing (EPH2).

E. DC/DC Converter (DC/DC)

This is a modular unit that converts the 24V dc power into 5V dc and 14V dc, the system operating voltages. The unit also provides LED voltage indicators, test points and adjustments, as well as an input jack (RCA type) for Background Music.

F. Central Processor Board (CPB)

This board provides the system's main 16 bit microprocessor and operating memory. It controls all system activity including switching functions and feature operation. This board houses the Programmable Read Only Memory (PROM) with generic operating instructions, and Random Access Memory (RAM) for customer data base programming. A lithium battery is included for protection of the RAM memory. An RS-232C connector for data base printout and SMDR is included. Feature Package software is installed on this board at the factory (See FP description below). One (1) CPB is required per system.

G. Feature Package Software

The Feature Package installed on the CPB provides the generic operation and feature set available to the system. This Feature Package includes software to support such features as Least Cost Routing (LCR), Uniform Call Distribution (UCD), Hunt Groups, Direct Inward System Access (DISA)*, Voice Mail In-band integration and Remote Administration*. This one Feature Package will support a maximum configuration of 40* CO lines and 96* stations.

(* Additional hardware may be required.)

400.3 PORT CARDS**A. Central Office Interface Board (COB)**

Provides the interface for eight central office (DTMF or Dial Pulse) loop start lines. The board can be removed or inserted with KSU power ON, however, the "Normal/Service" switch should be in the "Service" mode before removing or inserting the board into the system. An in-use LED for each circuit and a switch to take the board out of service are provided.

The CO circuits are equipped with programmable current sensing circuitry that identifies distant end disconnect loop supervision, if provided by the Central Office.

B. Amplified Central Office Interface Board (COA)

The Amplified Central Office Interface Board (COA) is an optional card that installs in place of any standard COB board. The COA enhances audio levels and contains all other attributes of the COB. The COA is recommended for DISA and multi-line conference applications and should not be used in the System behind a PBX because of possible feedback. When Amplified CO operation is desired, it is recommended that all CO circuits in the system be equipped on COA Boards.

C. Key Station Interface Board (KIB)

Provides interface circuitry for eight Key Telephones. The KIB will support any Starplus® Basic, Enhanced or Executive Key Telephone set. The KIB board can be inserted or removed with the KSU power ON, however, the "Normal/Service" switch should be in the "Service" mode before removing or inserting the board into the system. An in-use LED and a switch to take the card out of service are provided. A DSS/DLS or Phone Box can also be assigned to any one of the circuits. The KIB circuits are protected from mis-wiring and overcurrent.

D. Single Line Telephone Interface Board (SIB)

The Single Line Telephone Interface Board provides interface for eight (8) -24 vdc single line (2500 type) telephones. Single Line Telephone Interface Boards (SIB's) and Key Station Interface Boards (KSB's) are interchangeable within the system. Both standard DTMF and message waiting (90V) DTMF single line telephones may be used. An SIB or an OPX Board is required when connecting to a Voice Mail System and In-Band Integration is desired. An Application Board (APL) and a Ring Generator (RG) are required when installing SIB's.

E. Off-Premise Extensions Board (OPX)

The Single Line OPX Board provides four (4) -48 vdc FCC registered 2500-type single line interface ports. When an OPX is installed, the maximum number of stations in the system is reduced by four. OPX station features are the same as SLT station features. The only exception is "Receiving Message Waiting Indication", which is not allowed. Thus, OPX stations cannot answer a message waiting indication since they are incapable of receiving such an indication. All other feature operation is identical to that of on-premise SLT stations.

Each OPX port requires an OL13C network circuit. An FCC registered interface, such as RJ21X, is required to connect to the public network. Only SLT devices capable of sending true DTMF can be used on an OPX circuit provided by the system. When an OPX board is installed, four station ports are rendered unusable, reducing the maximum number of stations in the system by four. For example, with an OPX board inserted into the second KIB card slot extensions 108 through 111 support four OPX circuits (extensions 112 through 115 are not usable). An Application Board (APL) and a Ring Generator (RG) are required when installing an OPX Board.

400.4 OPTIONAL COMPONENTS**A. Application Board (APL)**

The Application Board (APL) provides the matrix and controlling circuitry for DISA, unsupervised conference and one external page zone as well as the circuitry for two DTMF receivers and two DTMF senders to support a small number of single line telephones. The APL has provisions for the addition of a Single Line DTMFRS Unit (SLU), used to support larger quantities of single-line telephones, and an RS-232C Module (RSM) to add an additional RS-232C port for outputting SMDR information only. This port cannot be used for programming locally or remotely via a terminal. The APL also has a connection for Recorded Announcement (RAN) input and its control contacts.

B. RS-232C Module (RSM)

This RS-232C Module (RSM) mounts on the Application Board (APL) and provides a second RS-232C connector. This connector may be used to output SMDR data while the standard RS-232C (located on the CPB) is used for system printout or Remote Administration.

C. Single Line DTMF Receiver/Sender Unit (SLU)

Used to expand the DTMF receivers and senders in the System to support single line telephones. The module is added to the APL board and contains four DTMF receivers and one DTMF sender.

Note: Adding the SLU is strongly recommended when SLT traffic is expected to be heavy or when connecting a Voice Mail or Automated Attendant to the 96EX System.

D. Power Failure Transfer Unit (PFT)

There can be two Power Failure Transfer Units installed in the Basic KSU, each providing automatic direct cut-through connection of six CO/PBX lines to six single line telephones in case of commercial power failure or system processor failure. The single line telephones may or may not be intercom stations. For each PFT installed there is one set of Loud Bell Control contacts provided. This unit can be removed or inserted with power on the KSU. There is a manual switch that activates the PFT for testing purposes.

E. Battery Charging Unit (BC)

The Battery Charging Unit (BC) installs into the External Power Supply Housing (EPH2) and provides the charging circuitry for a 24V dc battery package. The charging rate is 28V dc at 0.5 ampere for the Basic KSU or 2.0 ampere with the Expansion KSU (when the second Power Supply is added).

F. Single Line Ring Generator and M/W Power Supply Unit (RG)

Provides the 90V ac, 20 Hz, ringing supply for supporting single line telephones and OPX's. Also provides the voltage to light single line telephone M/W lights when SIB cards are installed in the system. This unit plugs into the External Power Supply Housing 2 (EPH2). One (1) unit is required when the system will be equipped with single line telephones.

400.5 STATIONS**A. Basic Key Telephone**

The Starplus Basic Electronic Telephone (Fig. 400-2) is a fully modular instrument with 8 fixed feature buttons and 6 button that can be flexibly assigned as CO/PBX/Centrex lines, Station DSS, or feature/function buttons. This telephone features On-hook dialing, Call Announce, Intercom, two (2) Volume Controls, a Personal Directory, and long life LED's. The



Basic Model

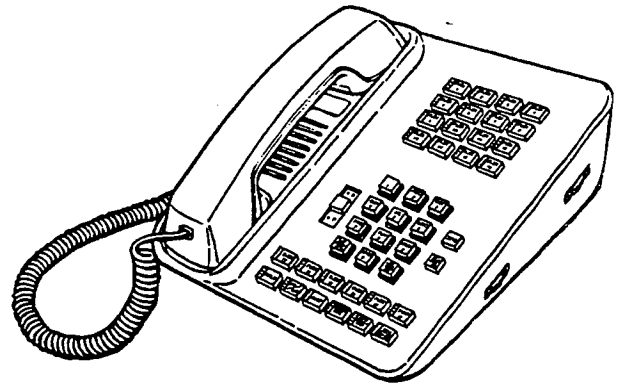

Enhanced Model



Executive Model

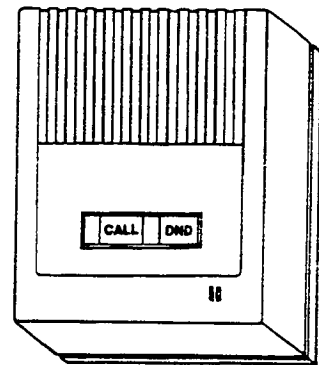

Phone Box

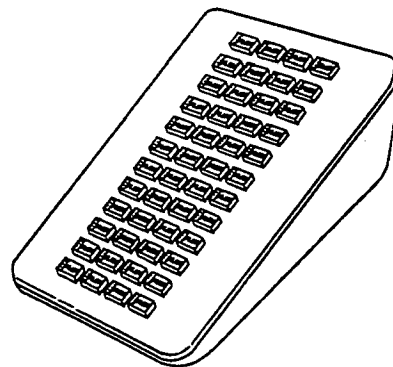

DSS/DLS Console

Figure 400-2 STARPLUS® Station Instruments

Basis Key Telephone does not provide either full speakerphone or Handsfree reply on intercom.

B. Enhanced Key Telephone

The Starplus Enhanced Electronic Telephone (Fig 400-2) is a fully modular instrument with 8 fixed feature/function buttons and 22 buttons that can be flexibly assigned as CO/PBX/Centrex lines, Station DSS, or feature/function buttons. This telephone also features an integrated speakerphone, call announce with handsfree intercom, two (2) Volume Controls, Intercom select switch, and long life LED's.

C. Executive Electronic Telephone

The Starplus Executive Key Telephone is a fully modular instrument with 8 fixed feature/function and 22 flexible buttons that can be flexibly assigned as either CO/PBX/Centrex lines, Station DSS, or feature/function buttons. This set also features an integrated 48 character LCD display, and integrated speakerphone, call announce with handsfree intercom, two (2) volume controls, an intercom mode select switch, and long life LED's.

D. DSS/DLS Consoles

The station port used for a DSS/ DLS Console can be assigned as a Direct Station Select or Direct Line Select depending on customer need. The bottom two rows of buttons on the DSS/DLS Console (Refer to Figure 400-2) contain 6-8 flexible buttons (depending on MAP chosen) which can be assigned by the station user in the same manner and functions as the flexible buttons on the keyset. Refer to Sec. 630 for an explanation of the 5 DSS/DLS mapping options.

E. Phone Box

The Phone Box (Refer to Figure 400-2) allows Handsfree conversations for locations that do not need dialing privileges. Phone Boxes may be substituted for Key Telephones on a one-for-one basis.

400.6 SYSTEM CAPACITY

The system is divided into two KSUs: one Basic and one Expansion KSU. The Basic KSU is housed in a wall-mountable cabinet that contains the backplane, two pre-wired connectors for Power Failure Transfer units, station and CO line boards, DC/DC Converter and an Applications board. This Basic KSU has a capacity of 24 CO lines and 48 Key Telephones and/or Phone Boxes. DSS/DLS's can be installed in place of any Key Telephone. Standard single line telephones (2500 type) can be installed by exchange-

ing key station interface boards. Eight single line telephones can replace eight Key Telephones for each board exchanged. An ON/OFF switch is located on the left side of the Basic KSU.

The Expansion KSU is also housed in a wall-mounted cabinet that contains additional station and CO line boards and interconnection to extend matrix connections of the Basic KSU to the Expansion KSU.

The External Power Supply Housing (EPH2) houses up to two Power Supplies (PS), a Single Line Telephone Ring Generator and Message Wait Power Supply (RG) and a Battery Charging card (BC). The EPH2 is also housed in a wall-mounted cabinet.

400.7 SYSTEM SPECIFICATIONS

System capacity, electrical specifications, environmental specifications, and Loop limits are listed in Tables 400-1, 400-2, and 400-3 and 400-4. Dialing specifications are listed in Table 400-5. Dimensions and weight are listed in Table 400-7. Key telephone and Single Line telephone Audible Indications are listed in Tables 400-9, 400-13, 400-14 and 400-15. Key Telephone Visual Indications are listed in Tables 400-10, 400-11, and 400-12.

Table 400-1 System Capacity

Ports: CO/PBX/Centrex Stations Single Line Telephones OPX	40 max (24 in Basic KSU, 16 with Expansion KSU). 96 max (48 in Basic KSU, 48 with Expansion KSU) 88 max (40 in Basic KSU, 48 with Expansion KSU) 44 max (each OPX Board reduces station capacity by 4)(20 in Basic KSU, 24 in EKSU)
Attendants: DSS/DLS Consoles:	Up to 3 stations can be designated as attendant(s). 72 max, up to 3 DSS/DLS units can be programmed to function with each station. (Each DSS/DLS unit reduces station capacity by 1)
Phone Boxes:	95 max (replaces key station port(s) on a 1 for 1 basis)
UCD: Groups: Members: RAN Announcements: Calls in Queue:	8 Groups 64 Members (up to 8 per group) 2 max per system up to 40 CO lines may be in queue per group
Hunt Groups: Groups: Members: Types:	8 Groups 64 Members (up to 8 per group) Station or Pilot (Programmable)
Voice Mail: Groups: Ports: Integration Method: VM Message Wait: VM Disconnect Signal:	8 Groups 64 Ports (up to 8 per group) In-Band Signaling (DTMF) Yes ([60] Turn on; [61] Turn off) CO Lines - Programmable 12 digit (DTMF) string if no digits are pre-programmed 15 seconds of silence followed by busy tone. Stations - 15 seconds of silence followed by busy tone.
SMDR Ports:	1 port (either located on the CPB or on the optional RS-232C Module (RSM) mounted on the APL Board)
Station Cards: KIB	Each KIB Board supports eight (8) electronic telephones, phone boxes or DSS/DLS units
SLT OPX	Each SIB Board supports eight (8) 2500-type (DTMF) telephones Each OPX Board provides four (4) FCC Registered OPX ports (reduces system station capacity by four (4) ports)
CO Cards: COB COA	Each COB Board can support up to eight (8) loop start CO/PBXCentrex lines. Each COA Board can support up to eight (8) loop start CO lines.

Table 400-1 System Capacity (Cont'd)

DTMF Receivers:	6 max (two (2) on the APL four (4) additional provided on the optional SLU board)
DTMF Senders:	3 max (two (2) on the APL, one (1) additional provided on the optional SLU board)
Page Zones:	4 Zones
Internal:	1 Zone (Requires APL Board)
External:	

Table 400-2 Electrical Specifications

AC Input to Power Supply	117V ac \pm 10%, 60 Hz single phase
Power Consumption	120v AC @6A 720 watts (maximum) (2 power supplies + Expansion KSU)
Power Supply Fuse - AC input	5A 125V AC
Longitudinal Balance:	60 db from 200 Hz to 1,000 Hz 40 db from 1,000 Hz to 4,000 Hz
Idle Channel Noise:	Less than 15 dbrnco for all connections
Cross Talk Attenuation:	Greater than 75 dbm Station to CO and Station to Station
Single Frequency Distortion: (300 Hz - 3,400 Hz)	Station to CO Line and Station to Station: Better than 2.0% or 34 db Output level -30 dbm to 0 dbm
Ringling Sensitivity:	16 Hz to 30 Hz at 40 VRMS minimum 30 Hz to 67 Hz at 50 VRMS minimum
Ringer Equivalence Number: (REN)	0.5B
CO Line Signaling - DTMF:	Frequency pair at -5 dbm +1.0 dbm Frequency tolerance \pm 1.5%
Input Level Range:	+10 db maximum
Music Source (input)	2 mW max. at 0 dBm 2K ohms input impedance
Contact Rating	
External Page Control	1.0A, 24V dc
Loud Bell Control	1.0A, 24V dc
RAN Port Control	1.0A, 24V dc
External Page Port	
Output Impedance	600 ohms @ 0 dBm
Output Power	1 mW Maximum
UL File Number:	E109461

Table 400-3 Environmental Specifications

Operating Temperature	32° to 104° F
Recommended Operating Temperature	70° to 78° F
Storage Temperature	-40° to 140° F
Relative Humidity	5% to 90% non-condensing
Heat Dissipation (BTU's)	2450 BTU's Maximum (Both power supplies)

Table 400-4 Loop Limits

Electronic Telephone: (including Single Line Telephone, Phone Box, and DSS/DLS)	500 feet of 26 AWG Cable 1000 feet of 24 AWG Cable 1500 feet of 22 AWG Cable
Off-Premise Extensions (OPX)	1400 Ohms maximum loop, not including tele- phone.

Table 400-5 Dialing Specifications

DTMF Dialing	
Frequency Deviation	±1%
Rise Time	3 msec.
Duration of DTMF Signal	75 msec. minimum
Interdigit Time	75 msec. minimum
PULSE Dialing	
Pulse Dialing Rate	10 or 20 pps.
Pulse Break/Make Duration	60/40 or 66/33
Dialing Memory	
System Speed Dialing	80 numbers (24 digits)
Station Speed Dialing	20 numbers (24 digits)
Save Number Redial	1 number (32 digits)
Last Number Redial	1 number (32 digits)
CO Type	Loop Start

Table 400-6 FCC Registration Numbers

For Systems configured as a key system (button appearance) use:	DLP82V-17568-KF-E
For Systems configured as a hybrid system (dial access codes) use:	DLP82V-17568-MF-E

Table 400-7 Dimensions and Weight

BASIC KEY SERVICE UNIT		EXPANSION KEY SERVICE UNIT	
Height	17.8"	Height	17.8"
Width	23"	Width	15.6"
Depth	13.3"	Depth	13.3"
Weight	60 lbs. (unloaded)	Weight	45 lbs. (loaded)
EXTERNAL POWER SUPPLY HOUSING (EPS)		POWER SUPPLY	
Height	13.1"	Height	4.75"
Width	13.5"	Width	4"
Depth	12..8"	Depth	9"
Weight	36 lbs. (loaded)	Weight	5 lbs.
DSS/DLS CONSOLE		KEY TELEPHONE	
Height	3"	Height	3.75"
Width	5.5"	Width	8.0"
Depth	9.125"	Depth	8.5"
Weight	2 lbs.	Weight	3 lbs.
PHONE BOX			
Height	1.75"		
Width	5.5"		
Depth	4"		
Weight	1 lb.		

Table 400-8 Miscellaneous Specifications

<p>Memory:</p> <p>Random Access Memory (RAM):</p> <p>Programmable Read-Only-Memory (PROM)</p> <p>Telephone Transmitter:</p> <p>Talk Paths:</p> <p>CO/PBX/Centrex paths:</p> <p>Intercom Paths:</p> <p>Music Channels:</p> <p>Account Codes:</p> <p>Number of digits per code:</p> <p>Number of Account Codes:</p> <p>Speed Dialing Capacity:</p> <p>System Speed</p> <p>Station Speed</p>	<p>128K expandable to 512K.</p> <p>384K expandable to 512K.</p> <p>Electret mic compatible.</p> <p>40 CO/PBXCentrex talk paths (non-blocking)</p> <p>14 talk paths (only 12 available for SLTs)</p> <p>1 channel provides music for music-on-hold and background music</p> <p>up to 12 unverified digits</p> <p>unlimited</p> <p>1360 total bins in system</p> <p>80 bins per system</p> <p>1280 bins per system</p>
---	--

Table 400-9 Key Telephone Audible Signals

TYPE OF SIGNAL	FREQUENCY	SIGNAL DURATION
<u>Key Telephone Signals:</u>		
Incoming CO Line	1215/1471	0.8s on/2.4s off; repeated
Intercom Tone Ringing	1215/1471	0.4s on/0.4s off/0.4s on/2.0s off
Intercom Call Announce (H-P)	935	0.2s on/0.2s off (3 bursts)
Transferred CO Line	1215/1471	0.8s on/2.4s off
CO Line Recall	1215/1471	0.8s on/2.4s off
Message Wait Call Back	1215/1471	0.4s on/0.4s off/0.4s on/2.0s off
Message Wait Reminder Tone	771	0.6s on (timed)
CO Queue Call Back	1215/1471	0.2s on/0.6s off; repeated
Camp-on	1215/1471	0.2s on/0.2s off/0.2s on (once)
Paging Alert Tone	935	1 sec. (burst)
<u>Key Telephone Confidence Tones:</u>		
Intercom Ringback	701	0.4s on/0.4s off/0.4s on/2.0s off
Call Announce	935	0.2s on/0.2s off (3 bursts)
Busy Tone	701	0.4s on/0.4s off, repeated
Error Tone	701	0.2s on/0.2s off, repeated
Intercom Dial Tone	701	Continuous
DND Tone	701	0.2s on/0.2s off, repeat 3x's. pause, 0.5s repeat
Paging Confirmation	935	1 sec burst
Programming Confirmation	1471	1.4 sec burst
Programming Error	1471	0.2s on/0.2s off, 6x's
Confirmation Tone	1471	1 sec burst, 1 time

Table 400-10 DSS/BLF Button Visual Indicators

TYPE OF SIGNAL	INDICATOR FLASH RATES
Off-Hook/Busy (All Stations)	Steady
Incoming Intercom Ring (Destination)	120 ipm flutter
Call Announce (Destination)	120 ipm flutter
Message Waiting Call Back (Destination)	120 ipm flutter
Do Not Disturb (All Stations)	60 ipm flash
Door Box Calling (Assigned Stations)	30 ipm flash
Automatic Call Back (Destination)	120 ipm flutter

Table 400-11 CO Line Button Visual Indicators

TYPE OF SIGNAL	INDICATOR FLASH RATES
Incoming CO Ring	30 ipm flash
Transferred CO Ring	120 ipm flash
Recall	480 ipm flutter
Queued Line	480 ipm flutter
Exclusive Hold	120 ipm flash
System Hold	60 ipm wink
I-Hold (only when hold preference is system)	30 ipm double flash
In Use	Steady

Table 400-12 Function Button Visual Indicators

TYPE OF SIGNAL	INDICATOR FLASH RATES
Call Forward (active)	30 ipm flash
Message Waiting (active)	15 ipm flash
Camp-on (active)	60 ipm flash
Call Back (active-initiator)	120 ipm flash
CO Line Queue (active)	Steady
Do Not Disturb (DND active)	60 ipm flash
Mute (microphone off, handset xmit off)	Steady
ON/OFF (speakerphone on/on-hook dialing)	Steady
Conference (active)	Steady
Hold (Camp-on)	120 ipm flash
Hold (all intercom channels busy)	Steady
Speed (momentarily ON until bin address dialed)	Steady
Personalized Messages	15 ipm flash
Intercom Call (Hold Button)	15 ipm flash
Loop	Same as CO Line buttons
Pool	Same as CO Line buttons
Transfer	Steady until transfer complete
Flash	Steady during dialing
Pickup	Momentary ON

Table 400-13 Single Line Telephone Audible Signals

TYPE OF SIGNAL	FREQUENCY	SIGNAL DURATION
<u>Single Line Signals:</u>		
Incoming CO Line	20 Hz, 50-90V AC	2.0s on/4.0s off
Intercom Tone Ringing	20 Hz, 50-90V AC	1.0s on/0.2s off/0.8s on/4.0s off
Transferred CO Line	20 Hz, 50-90V AC	2.0s on/4.0s off
CO Line Recall	20 Hz, 50-90V AC	2.0s on/4.0s off
CO Queue Call Back	20 Hz, 50-90V AC	2.0s on/4.0s off
<u>Single Line Confidence Tones:</u>		
Intercom Ringback	440	1.0s on/3.0s off; repeated
Call Announce	440	0.2s on/0.2s off (3 bursts)
Busy Tone	440	0.5s on/0.5s off; repeated
Error Tone	440	0.5s on/0.5s off; repeated
Intercom Dial Tone	440	Continuous
DND Tone	440	0.2s on/0.2s off, repeat 3x's, pause, 0.5s; repeated
Paging Time-out	440	0.5s on/0.5s off; repeated
Call FWD Warning Tone	440	0.2s on/0.2s off (six times)
Camp-on Tone	440	0.2s burst (1 time)
Conference Warning Tone	440	1 sec burst (1 time)
Confirmation Tone	440	1.4 sec burst (1 time)
DND Warning Tone	440	0.2s on/0.2s off (6 bursts)

Table 400-14 Ring Gen./Message Wait (RG) Specifications

Ring Generator Input:	24 Vdc
Ring Generator Output:	20 Hz, 50-90 VAC
Message Waiting Output:	90 V dc, unregulated
Ring Generator Capacity:	
Simultaneous Ringing (same cadence):	5 Single Line Telephones
Ring Cycles:	5
Maximum Number of Simultaneous SLTs ring ing:(cycled)	25

Table 400-15 OPX Telephone Audible Signals

TYPE OF SIGNAL	FREQUENCY	SIGNAL DURATION
<u>OPX Signals:</u>		
Incoming CO Line	20 Hz, 50-90V AC	2.0s on/4.0s off
Intercom Tone Ringing	20 Hz, 50-90V AC	1.0s on/0.2s off/0.8s on/4.0s off
Transferred CO Line	20 Hz, 50-90V AC	2.0s on/4.0s off
CO Line Recall	20 Hz, 50-90V AC	2.0s on/4.0s off
CO Queue Call Back	20 Hz, 50-90V AC	2.0s on/4.0s off
<u>OPX Confidence Tones:*</u>		
Intercom Ringback	440+480	1 s on/3s off
Busy Tone	480+620	0.5s on/0.5s off; repeated
Error Tone	480+620	0.25s on/0.25s off, repeated
Intercom Dial Tone	350+440	Continuous
DND Tone	480+620	0.2s on/0.2s off, repeat 3x's, pause, 0.5s; repeated
Paging Time-out	480+620	0.5s on/0.5s off
Call FWD Warning Tone	350+440	0.2s on/0.2s off (six times)
Camp-on Tone	350+440	0.2s burst (1 time)
Conference Warning Tone	480+620	1 sec burst (1 time)
Confirmation Tone	350+440	1.4 sec burst (1 time)
DND Warning Tone	350+440	0.2s on/0.2s off (6 bursts)
*Precise Tone Plan		

400.8 MEAN TIME BETWEEN FAILURE (MTBF)

The Mean Time Between Failure (MTBF) for each component of the 96EX Key Telephone System is shown in Table 400-16. The MTBF figures are calculated based on:

- Specifications: BellCoRe "TR-TSY-000332"
- Quality Factor: Level 2
- Environmental Factor: Group Benign (1.0)
- Method: Parts Count Method

Mean Time Between Failure (MTBF) represents for a particular interval, the total functioning life of a population of an item divided by the number of failures within the population during the measurement interval. The definition holds for the time, cycles, miles, events, or other measures of life units. This does NOT provide a definite failure time but only indicates possible failure probabilities based on calculations.

To calculate a particular systems MTBF:

1. multiply the quantity of each component in the system by its failure rate.

Component	Qty	X	Failure Rate	=	Resultant
Power Supply	2	X	2064.2	=	4128.4

2. Add the resultants from step 1 for all components used to configure a system.

3. Divide the total number derived from step 2 into 1,000,000,000. This will provide the system's MTBF rated in hours.

$$\frac{1,000,000,000}{\text{Total (from Step 2)}} = \text{System MTBF Rated in Hours}$$

Table 400-16 Mean Time Between Failures (MTBF)

DEVICE	FAILURE RATE	MTBF IN HOURS (for a single unit)	MTBF IN YEARS (for a single unit)
Basic Key Service Unit (BKSU)	574.7	1740038.3	198.6
Expansion Key Service Unit (EKSU)	356.9	2801905.3	319.9
Power Supply Unit (PS)	2064.2	484449.2	55.3
DC/DC Converter (DC/DC)	4160.0	240384.6	27.4
Central Processor Board (CPB)	16179.3	61807.4	7.1
Central Office Interface Board (COB)	9341.4	107050.3	12.2
Key Station Interface Board (KIB)	5093.0	196347.9	22.4
Single Line Interface Board (SIB)	10677.4	93655.8	10.7
Application Board (APL)	7818.7	127898.5	14.6
RS-232C Module (RSM)	1212.4	824810.3	94.2
Single Line DTMFRS Unit (SLU)	825.2	1211827.4	138.3
Power Failure Transfer Unit (PFT)	1615.0	619195.0	70.7
Ring Generator Unit (RG)	1509.0	662690.5	75.6
Battery Charging Unit (BC)	2310.6	432788.0	49.4
Key Telephone	6022.9	166033.0	19.0
DSS/DLS Console	2511.3	3986200.1	45.5
Phone Box	4209.2	237574.8	27.1

SECTION 500

INSTALLATION

500.1 SITE PLANNING

The Starplus 96EX Hybrid Key Telephone System, like most electronic office equipment, should not be subjected to harsh environmental conditions. To assure easy servicing and reliable operation, several factors must be considered when planning the system installation. Always remember the following BEFORE installing the KSU and wiring:

- The Basic KSU, Expansion KSU and External Power Supply Housing are designed for wall mounting.
- Both power supplies operate on 117V ac, 60 Hz single phase electricity. A 3-wire (parallel blade with ground) receptacle must be provided on a dedicated, separately fused 15 ampere circuit.
- The KSU should be within 25 feet of the telephone company (Telco) RJ21X. The KSU should be centrally located and care should be taken to stay within prescribed cable lengths. It is recommended that 24 AWG 3-pair twisted cable be used.
- Mounting space for standard backboard, or a plywood type board for MDF blocks, if a standard backboard is not used.
- A well ventilated area having a recommended temperature range of 70 to 78 degrees Fahrenheit and a humidity range of 5 to 90% (non-condensing).
- Lighting and accessibility of KSU for servicing.
- Protection from flooding, flammable materials, excessive dust, and vibration.
- Proximity of radio transmitting equipment, arc welding devices, copy machines, and other electrical equipment that are capable of generating electrical interference.
- Access to a good earth ground such as a metallic COLD water pipe. Inspect the pipe for non-metallic joints.

500.2 UNPACKING THE 96EX BASIC SYSTEM

Remove the Key Service Unit from the shipping carton and stand it upright on a level working surface with the cover facing forward. Remove the cover by turning the two screws on the front of the cabinet 1/4 turn and tilting the cover outward.

Remove all remaining items from the Basic System packing box and inspect for shipping damage. The Basic System ships with all the components necessary for a working 8 CO line by 16 station system. The components included in the Basic System Package are:

- (1) Basic Key Service Unit (BKSU)
 - BKSU Mounting Template
- (1) External Power Housing 2 (EPH2)
 - EPH2 Mounting Template
 - AC Power Cord
 - Battery Bypass Board (installed in EPH2)
- (1) Power Supply (PS10)
- (1) DC/DC Converter (DC/DC)
- (1) Central Processor Board (CPB)
 - Including 96EX Installation Manual
- (1) Central Office Board (COB)
- (2) Key Station Interface Board (KIB)
 - Including 16 Key Station User Guides
- (1) Attendant User Guide

Optional System items are:

- Expansion Key Service Unit (EKSU)
- Additional Central Office Interface Board (COB)
- Amplified Central Office Interface Board (COA)
- Additional Key Telephone Interface Board (KIB)
- Single Line Telephone Interface Board (SIB)
- Off-Premise Extensions Board (OPX)
- Applications Board (APL)
- Single Line Telephone DTMFRS Unit (SLU)
- RS-232C Module (RSM)
- Power Failure Transfer Unit (PFT)
- Battery Charging Board (BC)
- Single Line Ring Generator and Message Wait Power Supply (RG)

Refer to Appendix B for a complete component offering and their associated part numbers.

500.3 SYSTEM GROUNDING

To ensure that the system will operate properly, a good earth ground is required. Use of the Telco ground (source not demark) or a metallic COLD water pipe usually provides a reliable ground path. Carefully check that the pipe does not contain insulated joints that could isolate the ground. In the absence of the COLD water pipe, a ground rod or other source may be used. A no. 8 AWG copper wire should be used between the ground source and the KSU and EPH2 (25 feet maximum). The farther from the ground source, the larger the ground wire used should be. The wire should be kept as short as possible and can be connected to the ground lug provided on the lower left side of the front face of the KSU (cover off) (Refer to Figure 500-1) and the right side of the EPH2.

500.4 KSU INSTALLATION

Refer to Figures 500-1, 500-2, and 500-3 for general mounting arrangements and dimensions. The KSU is mounted in the following manner:

The KSU is designed for wall mounting only, and should not be mounted directly on a masonry or dry walled surface. A wooden back-board (plywood or pressed board) of sufficient size should be attached to the wall for the KSU to be mounted upon. The KSU mounting template should be used to identify screw hole locations. It is important that the KSU and MDF connecting blocks be mounted on the back-board.

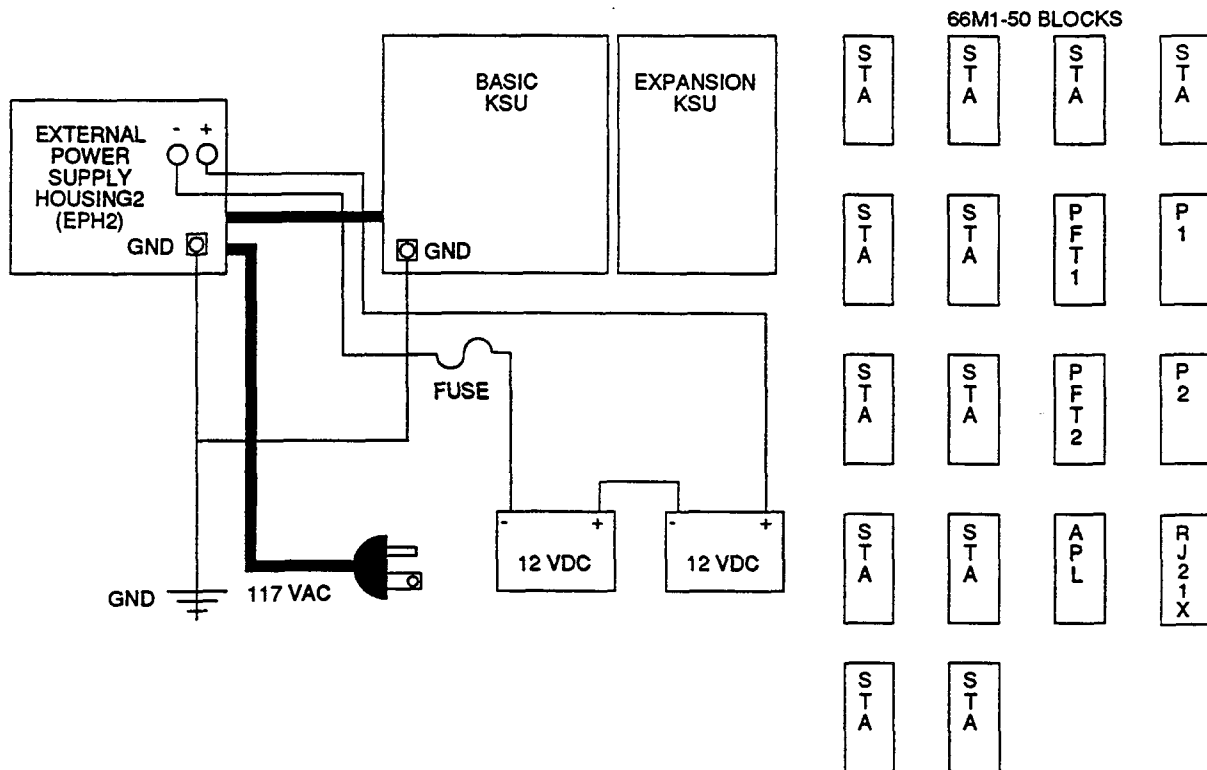

Figure 500-1 Mounting Arrangements

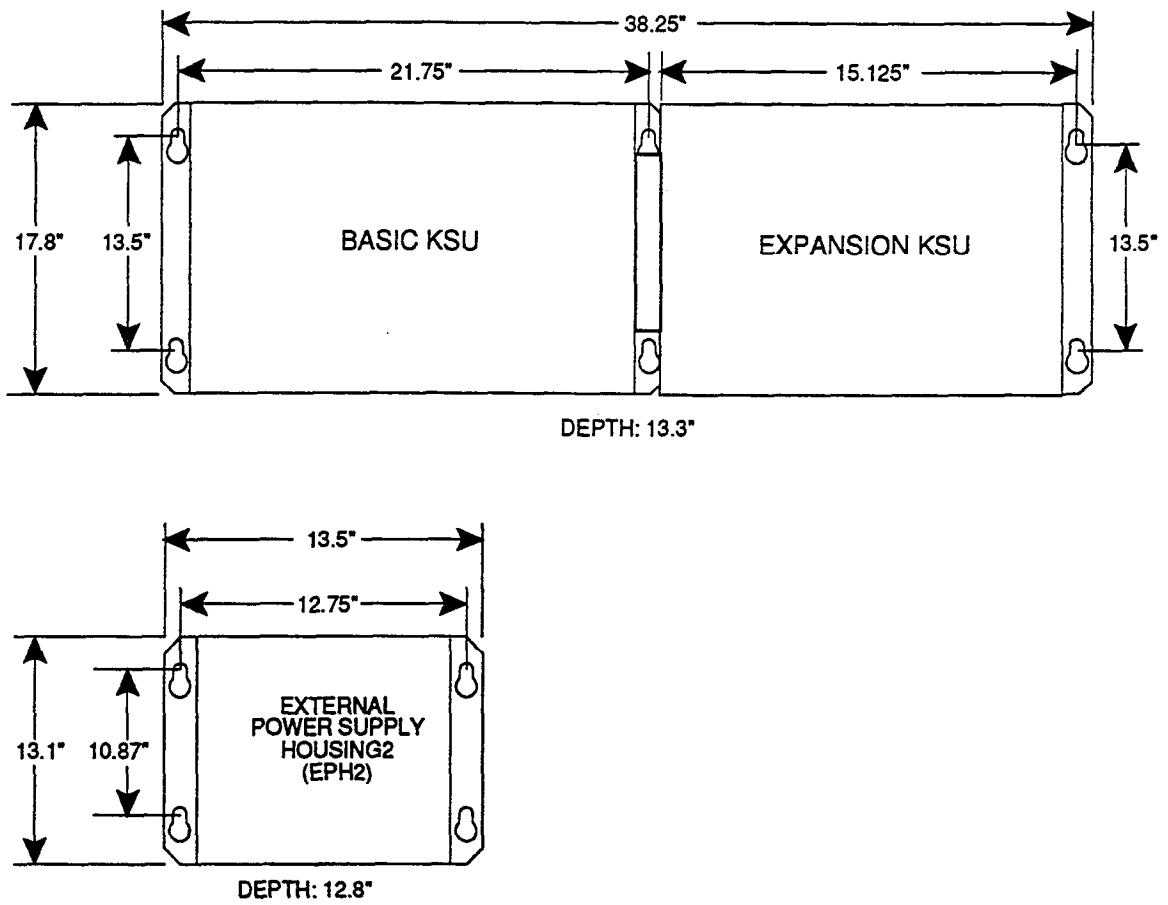

Figure 500-2 Mounting Dimensions

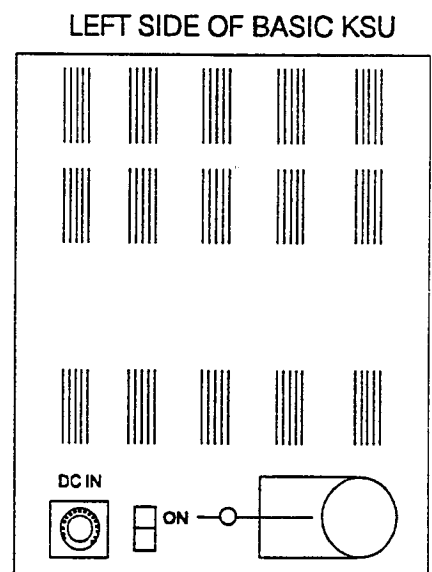
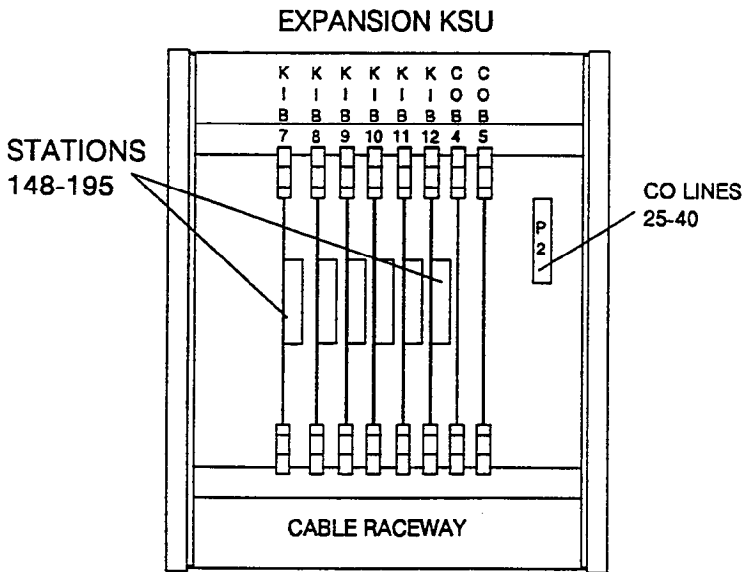
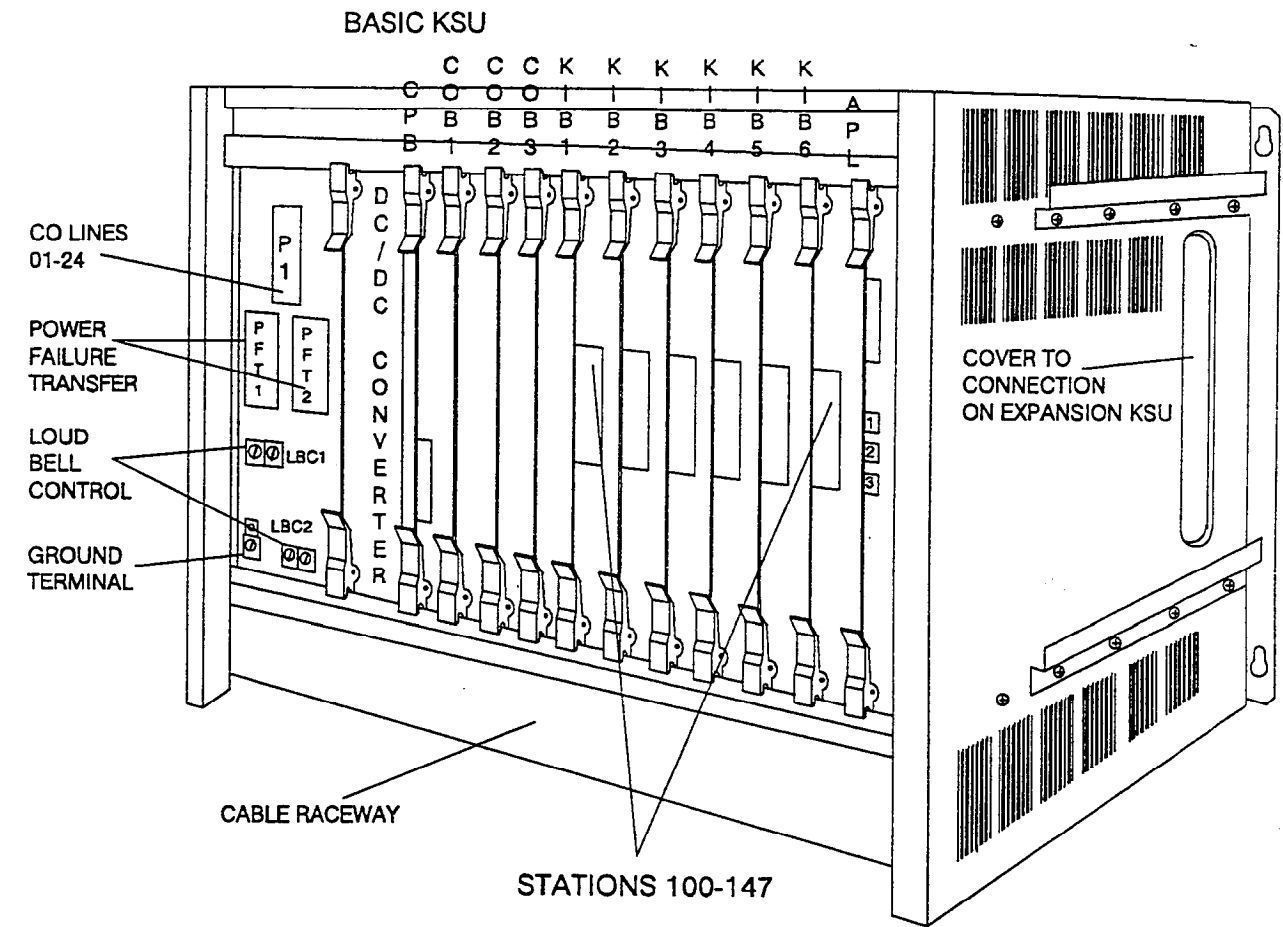

Figure 500-3 Basic KSU and Expansion KSU

- A. Insert 4 (#10 or larger) screws into the backboard and tighten enough to hold the weight of the KSU. Lift the KSU and place it onto the screws. When the KSU is in position, the screws can be tightened and the KSU is securely mounted.

500.5 LIGHTNING PROTECTION

The Starplus 96EX Hybrid Key Telephone System should have Central Office lines and OPX stations protected with proper lightning surge arrestors. This will provide protection from damaging surges on sensitive cabling by non-direct lightning strikes.

The protection should contain a compliment of three-element gas-discharged tubes to ground high potential surges, and associated circuits to absorb and filter lower level surges. This type of lightning protection is available through telephone equipment supply houses. Care should be taken to ensure that such protection devices are installed in accordance with the manufacturer's instructions and to ensure that no more than one set of protectors be installed on central office lines at the installation premises. Improper installation can be a serious safety hazard.

Failure to provide the proper lightning protection will increase maintenance expense and require more available spare parts.

500.6 EXTERNAL POWER SUPPLY HOUSING 2 (EPH2) INSTALLATION

NOTE: The second Power Supply (PS) must be added to the External Power Supply Housing when the Expansion KSU is added.

The External Power Supply Housing 2 should be wall mounted onto the same backboard as the KSU. The power supply must be located within three feet of a separately fused 15 ampere, 117V ac power outlet. A four foot DC output cord is provided for interconnection of the KSU and External Power Supply. A battery backup Bypass Board is installed in the BC slot of the External Power Supply Housing 2 (EPH2). This is required to provide system power when a Battery Charging (BC) card is not installed.

The power supply may be located to the left of the Basic KSU or above the BKSU.

NOTE: The right side of the Basic KSU should be reserved for the Expansion KSU. (Refer to Figures 500-1 and 500-2)

Using the template provided, spot punch the mounting surface through the template four corners. Install four (no. 10 or larger) screws into the backboard and tighten to about 1/8 inch from the mounting surface. Lift the EPH2 housing onto the four screws and tighten.

Connect the DC output cord of the EPH2 to the Basic KSU by aligning the connector pins, pressing inward, then turning the collar of the connector clockwise until tight.

WARNING

Do not connect AC power cord to an AC outlet at this time.

500.7 POWER SUPPLY (PS) INSTALLATION

Install the Power Supply(ies) into the EPH2 housing by sliding them into their respective mounting slots. Lock the power supply(ies) into the EPH2 housing by sliding the mounting lock to the left and tightening by turning clockwise (Refer to Figure 500-4).

Plug the associated AC IN power cord into the AC IN socket on the Power Supply(ies). Then plug the DC cord into the DC output connector on the power supply(ies).

500.8 BATTERY BACK UP INSTALLATION

A Battery Charging Unit (BC) is an option that can be installed in the External Power Supply Housing 2 and will maintain system operation during loss of AC power. A separate external 24V dc battery package must be provided.

WARNING

Do not make connections with the power applied to the External Power Supply Housing 2. Also remove power from the KSU by turning the power switch to off (located on the left side of the BKSU).

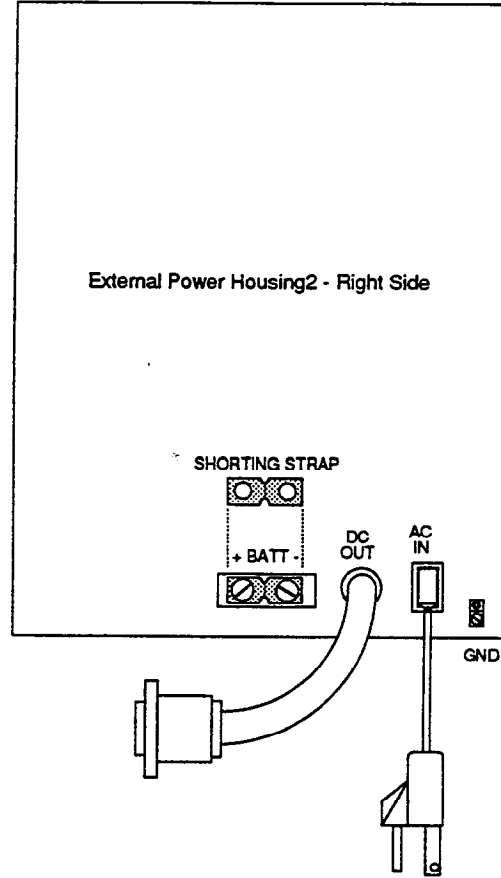
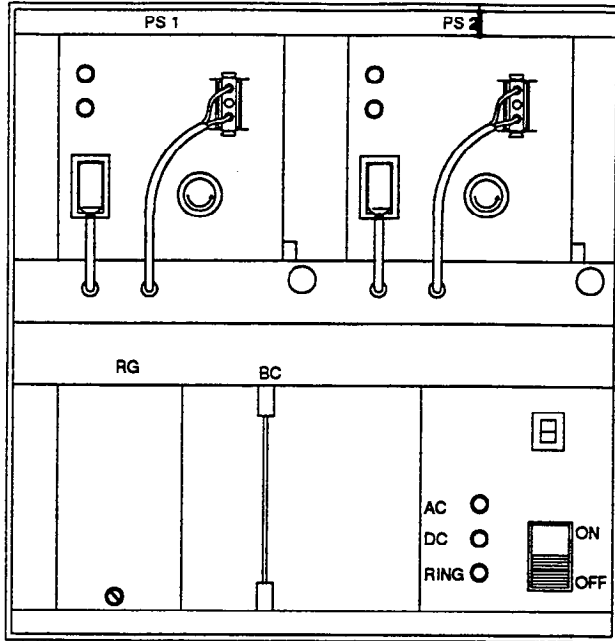

96EX Power Supply (PS)

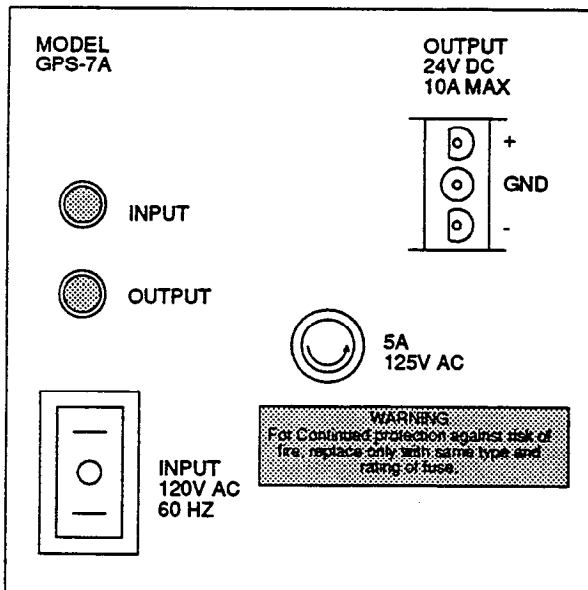

CAUTION: Remove the shorting strap from the battery connecting terminals on the right side of the EPH2 before connecting batteries.

Figure 500-4 Ext. Power Housing2 (EPH2) & Power Supply

Before installing the Battery Charging Unit (BC) turn off the AC power switch on the front of the EPS. To install the BC, remove the cover of the External Power Supply Housing 2 (EPH2). Locate the BC card slot and remove the Battery Bypass Board.

Table 500-1 Battery Back Up Duration

Battery Amp Hour Rating	Configuration		
	16 x 32	24 x 48	40 x 96
7 AH	1 1/2 HR.	1 HR.	20 MIN.
14 AH	2 1/2 HR.	2 HR.	1 HR.
40 AH	7 HR.	5 1/2 HR.	3 HR.

The BC unit provides a Tone Emitter switch to enable (ON) or disable (OFF) tone signaling when System Battery Back Up is active (Refer to Figure 500-5). Install the Battery Charging (BC) unit with components facing right into the BC card slot of the EPH2.

CAUTION: IMPORTANT STEP

Remove the shorting strap from the battery connection terminals on the right side of the EPH2 before connecting batteries.

External batteries may now be connected using stranded wire with crimp on ring terminals. A 24V dc (normally two 12V dc batteries) package with a 40 ampere hour rating is considered maximum. It is recommended that maintenance free gel-type batteries be used. The following should be considered when connecting batteries:

- Batteries are to be placed in a limited access room or cabinet with adequate ventilation of any battery gases that may be present.
- A battery rack or case should be used to secure

the batteries and protect them.

- Use the shortest length of stranded wire possible to connect the batteries. Use wire sizes recommended by the National Electrical Code and/or local regulations.
- The batteries you are installing MUST be fully charged.
- The battery voltage of both 12v batteries connected in series MUST be 22v or greater in order for the Starplus 96EX to function properly.

If the manufacturer's suggested float charge voltage of the batteries is different than 27.3 ± 3v, then the installer MUST contact VCS Field Service for the appropriate interface. This voltage should be for the ambient temperature expected for the equipment room.

A 12 ampere, 32V minimum fuse or a 12 ampere DC instantaneous tripping circuit breaker should be installed in line with the battery negative lead to protect the batteries from damage. Refer to the Typical Battery Interconnection Layout, Figure 500-6.

Depending on batteries used, the recharge time to completely recycle a fully discharged battery will follow the examples below:

Table 500-2 Battery Recharge Time

Battery Amp Hour Rating	Configuration	
	24 x 48 (Basic KSU)	40 x 96* (Basic + Expansion)
7 AH	12 HR.	6 HR.
14 AH	25 HR.	12.5 HR.
40 AH	72 HR.	36 HR.

*or second power supply installed in EPH2 housing.

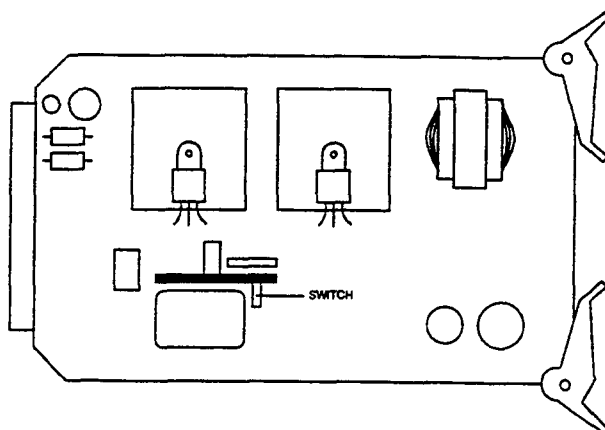

Switch ON= Tone Enabled
Switch OFF= Tone Disabled

Figure 500-5 Tone Emitter on BC Card

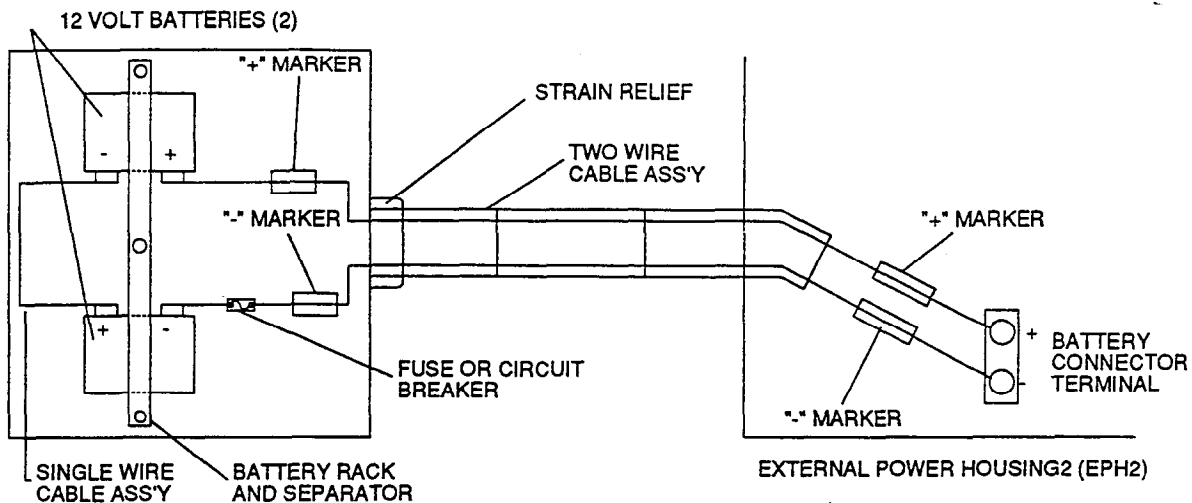

Figure 500-6 Typical Battery Interconnection Layout

500.9 PRINTED CIRCUIT BOARD INSTALLATION

The Printed Circuit Boards (PCB's) used to configure the system contain static sensitive components that will require a few simple handling precautions to avoid damage.

Keep all PCB's in their protective anti-static bags until they are installed in the KSU. All PCB's that are not in protective bags should be handled by the card edges only.

Never lay an unprotected PCB card on a carpeted surface.

WARNING

Always use a grounded wrist strap when handling PCB's. This will minimize the possibility of static damage.

A. Installing the DC/DC Converter Unit (DC/DC)

Locate and unpack the DC/DC Converter Unit (DCU). Using the ejector tabs, insert the unit into the BKSU card slot 0 or DC/DC card slot.

B. Installing PCBs

NOTE: With the exception of the CPB and DC/DC, PCBs can be safely unplugged with the power on but it is suggested that the Normal/Service switch be placed in the "service" mode while removing or inserting into the system.

When inserting a card into the KSU, make sure the card edges are aligned with the KSU card guides, that the service switch is in the service (down) position, and that the component side of the card faces to the right. Note, the card ejector tabs are color coded to match the designations on the KSU. Make sure the PCB's are securely seated in their respective card connectors.

Press firmly on the card ejector tabs once the PCB is mounted into the KSU. The service switch should be returned to the normal (up) position.

C. PCB Programming

The COB (Figure 500-9), COA (Figure 500-10), KIB (Figure 500-11) SIB and OPX cards each have a service switch on the front of the card. The switch should be in the Normal (up) position for normal operation.

The CPB has a DIP switch assembly for programming various system functions. Make sure the switches are positioned according to the functions described in Figure 500-8. The APL board provides connectors for SLU and RSM.

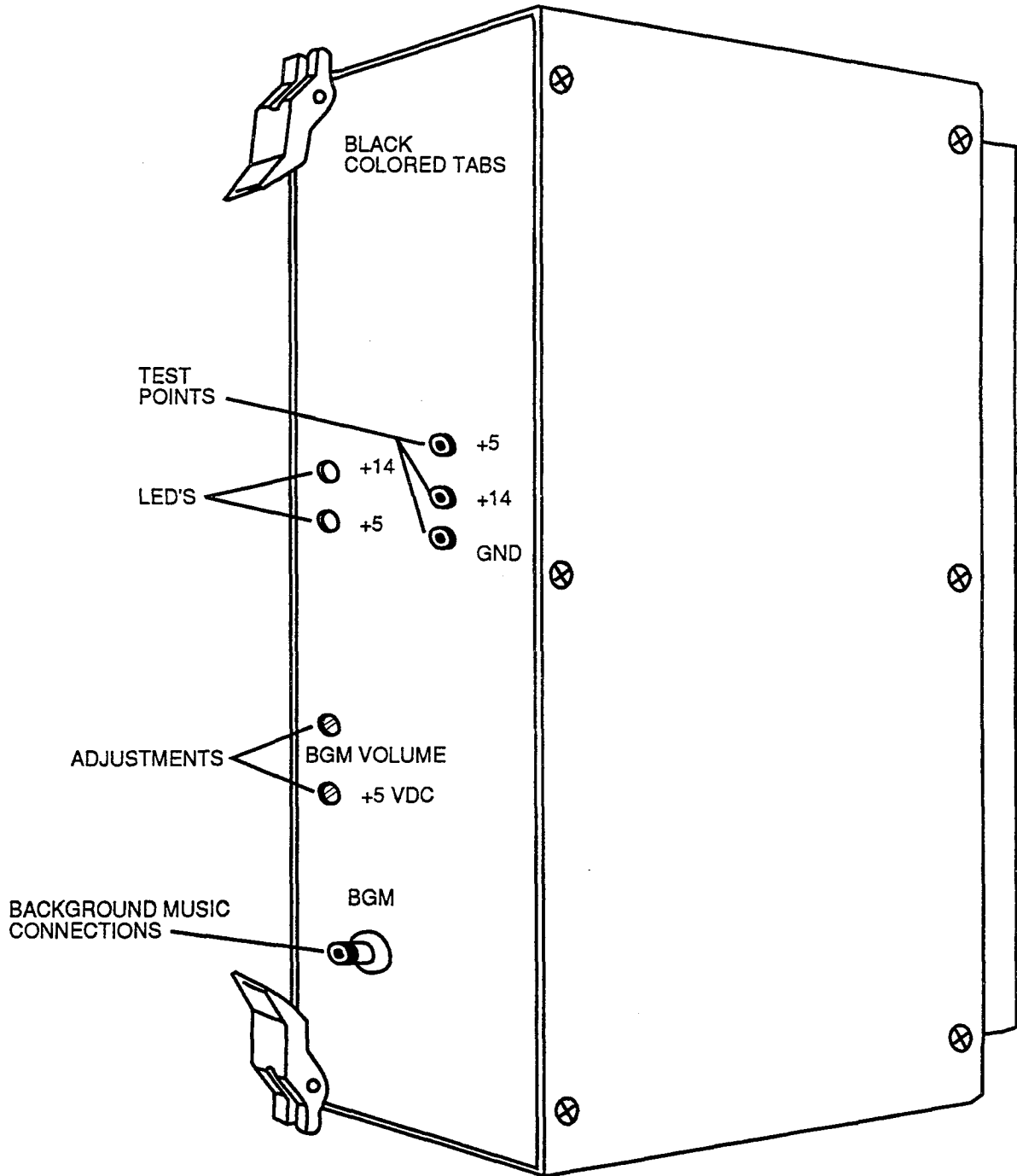

Figure 500-7 DC/DC Converter Unit (DC/DC)

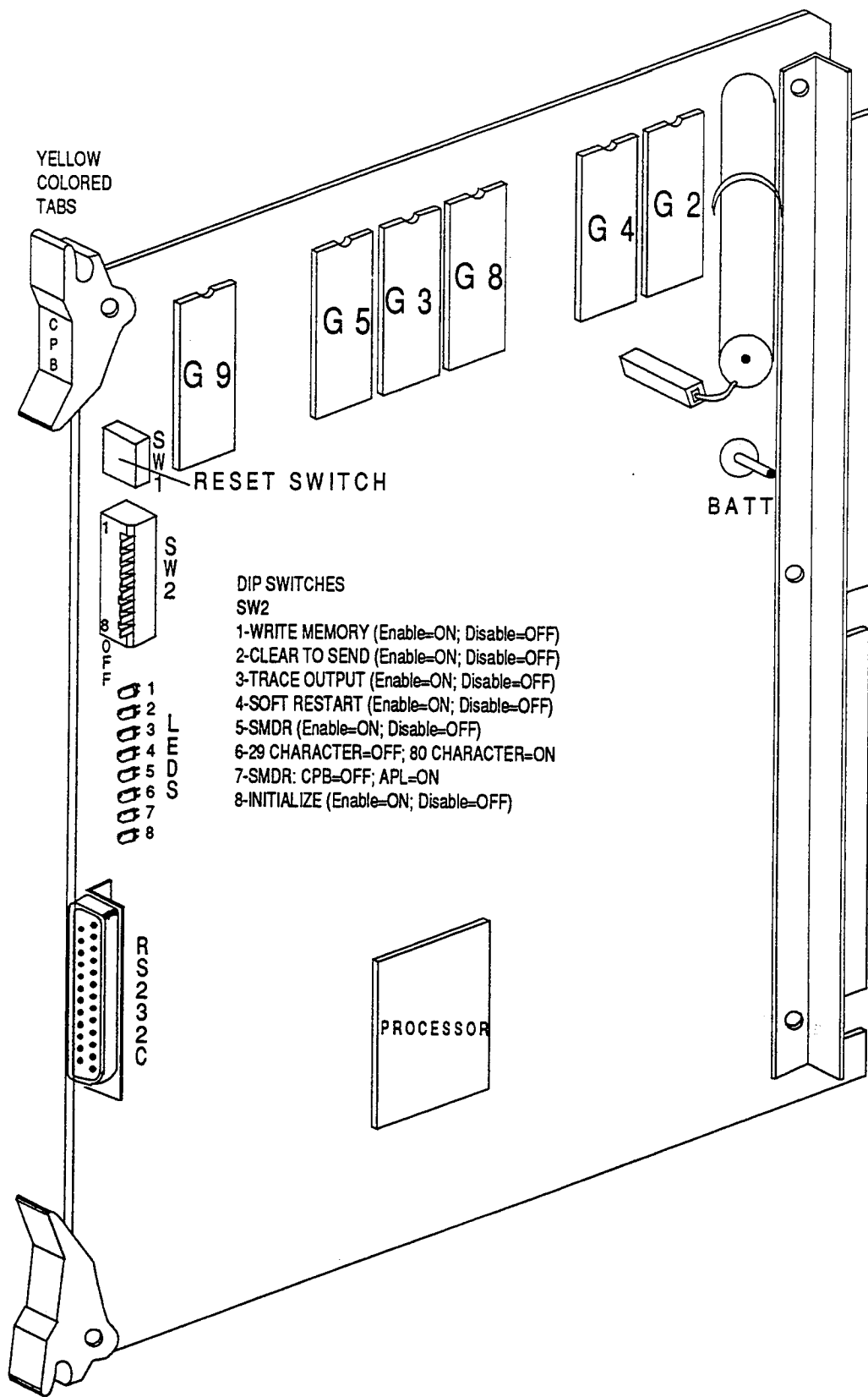

Figure 500-8 Central Processing Board (CPB)

500.10 CO/PBX CONNECTIONS

An FCC approved RJ21X connector should be supplied by the Telco at the demarcation point. The RJ21X should be located within 25 ft. of the KSU. All CO/PBX line connections are made on the P1 and P2 cables. The P1 connector is located in the Basic KSU and the P2 connector in the Expansion KSU. A COB or COA card must be installed in the associated KSU card slot in order for the CO/PBX line interface connections to be established (Refer to Tables 500-3 and 500-4).

500.11 AMPLIFIED CENTRAL OFFICE INTERFACE BOARD

There are eight CO line circuits per card. Each card has a jumper strap (one for each of the eight CO circuits) which is set by the installer during installation for either 0 db (no gain) or +3 db (gain). (Refer to Figure 500-10). Gain/no gain affects multi-line conferences and trunk to trunk (DISA or off-net forward) calls. All other installation requirements are the same as for the standard COB. When Amplified CO connections are desired it is recommended that all CO boards in the system be replaced with COA boards.

500.12 STATION CONNECTIONS

There is a 50-pin female amphenol-type connector on each station KIB, SIB and OPX card. These allow the system to be cabled to the main distribution frame (MDF). Twenty-five pair telephone cabling must be prepared with mating connectors to extend the KSU interface circuits to the MDF. The cables are routed through the cable clamps at the bottom of the KSU to the MDF. These cables are then terminated on industry standard 66M1-50 type punch-down connector blocks (Refer to Tables 500-5, 500-6, and 500-7). It is recommended that 66M1-50 split blocks with bridging clips be used to simplify troubleshooting and to quickly isolate faults.

The amphenol type connectors will be on the front edge of the printed circuits boards which are plugged into the green colored card slots. These connectors require male plug-ended cables for proper attachment. The actual quantity of cable required depends on the size of the system. Each time a station card is added to the system, another connector is required. A maximum of six station boards can be installed in the basic KSU.

After the amphenol type cable connector has been attached, the cable should be anchored to the cable clamps at the bottom of the KSU with tie wraps in order to prevent accidental disconnection.

The Expansion KSU contains four station slots (Refer to Figure 500-3).

500.13 POWER FAILURE TRANSFER AND LBC CONNECTIONS

The Power Failure Transfer Unit contains the Loud Bell Control contacts. The package should contain:

- 1 PFT
- 1 two-connector terminal strip
- 1 amphenol clip
- 2 jack screws
- 4 washer screws
- 1 plastic terminal strip protector

A. Power Failure Transfer (PFT)

A maximum of two, optional Power Failure Transfer Units (PFT) can be installed in the Basic KSU. In the event of a commercial power failure, up to six CO/PBX lines per PFT can automatically transfer to single line telephones for emergency communications. These SLT's can be either rotary or DTMF but must be equipped with CO powered ringers. These SLT stations do not have to be used for intercom, but can be if so desired.

The PFT also provides the contact closure for Loud Bell Control/CO Line Control. The PFT has a 50-pin male amphenol connector that allows a 25-pair cable to be installed and terminated at the MDF. (Refer to Figure 500-12 and Table 500-8 for PFT connections).

B. Loud Bell Control (LBC)

The Starplus 96EX System provides relay contact closure to activate optional external signaling equipment during incoming CO line ringing or to activate ancillary equipment.

The stations for Loud Bell Control are selected as part of system programming. Either or both of the LBC circuits may be assigned to any one station, to separate stations or to a CO Line to provide contact closure while that CO Line is busy. The dry contacts will follow the ringing condition of that station or will remain closed when assigned to a CO line.

The LBC contacts are installed underneath the PFT in the Basic KSU (Refer to Figure 500-3).

- A. Using the two jack screws, mount the two-connector terminal strip to the BKSU.
- B. Take the RD/OR wire on the back of the terminal strip and route through the slot where the PFT is mounted and connect to the RD/OR wire on the back of the PFT.
- C. Connect the appropriate wire (1 or 2) tie wrapped to the PFT mounting hole to the K1 connector on the PFT.
- D. Insert the PFT into the hole provided (Refer to Figure 500-3) and fasten with two washer screws.

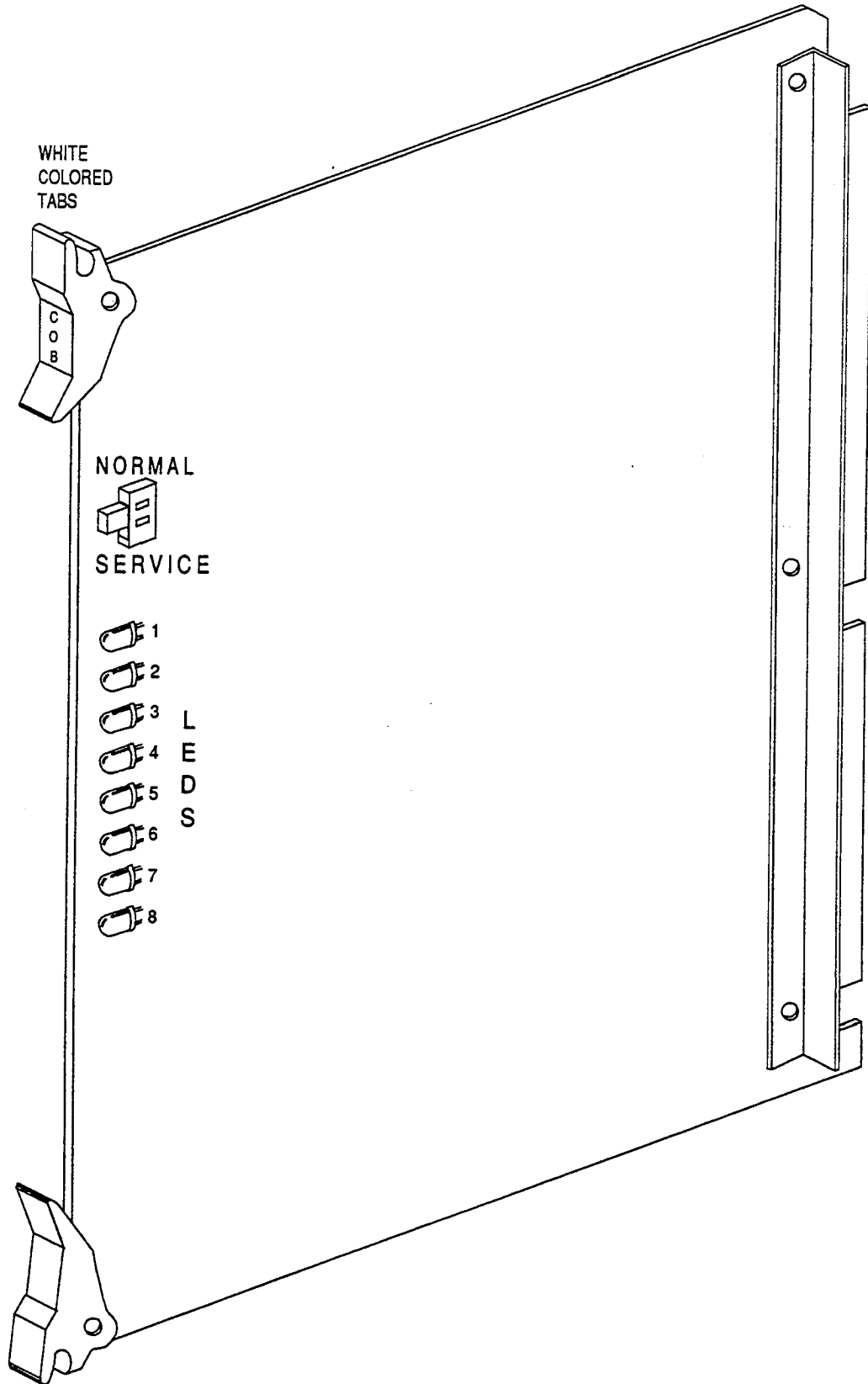

Figure 500-9 Central Office Interface Board (COB)

Table 500-3 P-1 Connecting Block

PAIR	PIN	COLOR	DESIG	DESCRP	
1	26	WH/BL	CO 1T		
	1	BL/WH	CO 1R		
2	27	WH/OR	CO 2T		
	2	OR/WH	CO 2R		
3	28	WH/GN	CO 3T		C
	3	GN/WH	CO 3R		
4	29	WH/BN	CO 4T		O
	4	BN/WH	CO 4R		
5	30	WH/SL	CO 5T		B
	5	SL/WH	CO 5R		
6	31	RD/BL	CO 6T	1	
	6	BL/RD	CO 6R		
7	32	RD/OR	CO 7T		
	7	OR/RD	CO 7R		
8	33	RD/GN	CO 8T		
	8	GN/RD	CO 8R		
9	34	RD/BN	CO 9T		
	9	BN/RD	CO 9R		
10	35	RD/SL	CO 10T		
	10	SL/RD	CO 10R		
11	36	BK/BL	CO 11T		C
	11	BL/BK	CO 11R		
12	37	BK/OR	CO 12T	O	
	12	OR/BK	CO 12R		
13	38	BK/GN	CO 13T	B	
	13	GN/BK	CO 13R		
14	39	BK/BN	CO 14T	2	
	14	BN/BK	CO 14R		
15	40	BK/SL	CO 15T		
	15	SL/BK	CO 15R		
16	41	YL/BL	CO 16T		
	16	BL/YL	CO 16R		
17	42	YL/OR	CO 17T		
	17	OR/YL	CO 17R		
18	43	YL/GN	CO 18T		
	18	GN/YL	CO 18R		
19	44	YL/BN	CO 19T		
	19	BN/YL	CO 19R		
20	45	YL/SL	CO 20T	C	
	20	SL/YL	CO 20R		
21	46	VI/BL	CO 21T	O	
	21	BL/VI	CO 21R		
22	47	VI/OR	CO 22T	B	
	22	OR/VI	CO 22R		
23	48	VI/GN	CO 23T	3	
	23	GN/VI	CO 23R		
24	49	VI/BN	CO 24T		
	24	BN/VI	CO 24R		
25	50	VI/SL	SPARE		
	25	SL/VI	SPARE		

Table 500-4 P-2 Connecting Block

PAIR	PIN	COLOR	DESIG	DESCRP	
1	26	WH/BL	CO 25T		
	1	BL/WH	CO 25R		
2	27	WH/OR	CO 26T		
	2	OR/WH	CO 26R		
3	28	WH/GN	CO 27T		C
	3	GN/WH	CO 27R		
4	29	WH/BN	CO 28T		O
	4	BN/WH	CO 28R		
5	30	WH/SL	CO 29T		B
	5	SL/WH	CO 29R		
6	31	RD/BL	CO 30T	4	
	6	BL/RD	CO 30R		
7	32	RD/OR	CO 31T		
	7	OR/RD	CO 31R		
8	33	RD/GN	CO 32T		
	8	GN/RD	CO 32R		
9	34	RD/BN	CO 33T		
	9	BN/RD	CO 33R		
10	35	RD/SL	CO 34T		
	10	SL/RD	CO 34R		
11	36	BK/BL	CO 35T		C
	11	BL/BK	CO 35R		
12	37	BK/OR	CO 36T	O	
	12	OR/BK	CO 36R		
13	38	BK/GN	CO 37T	B	
	13	GN/BK	CO 37R		
14	39	BK/BN	CO 38T	5	
	14	BN/BK	CO 38R		
15	40	BK/SL	CO 39T		
	15	SL/BK	CO 39R		
16	41	YL/BL	CO 40T		
	16	BL/YL	CO 40R		
17	42	YL/OR	---		
	17	OR/YL	---		
18	43	YL/GN	---		
	18	GN/YL	---		
19	44	YL/BN	---		
	19	BN/YL	---		
20	45	YL/SL	---		
	20	SL/YL	---		
21	46	VI/BL	---		
	21	BL/VI	---		
22	47	VI/OR	---		
	22	OR/VI	---		
23	48	VI/GN	---		
	23	GN/VI	---		
24	49	VI/BN	---		
	24	BN/VI	---		
25	50	VI/SL	---		
	25	SL/VI	---		

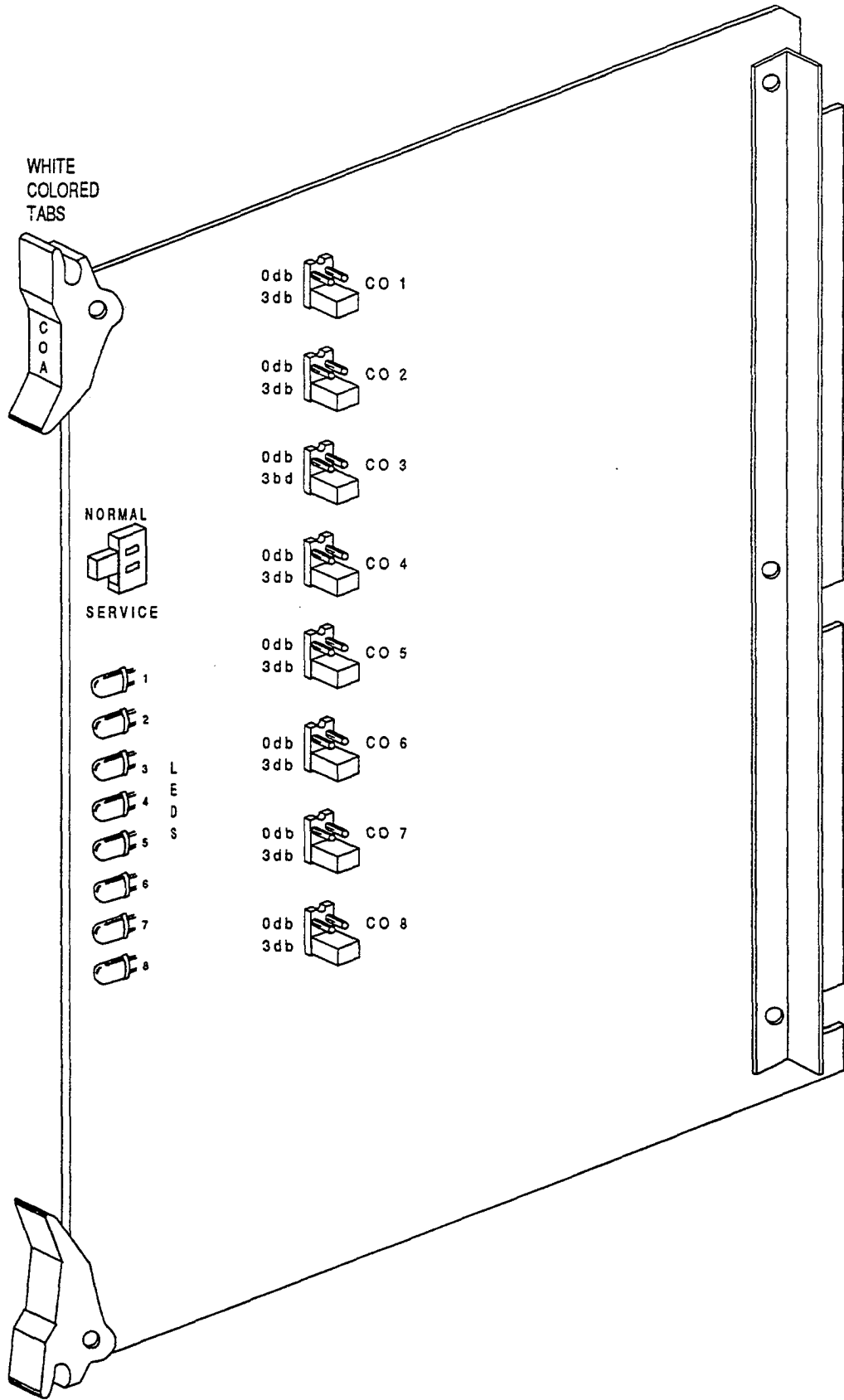

Figure 500-10 Amplified CO Interface Board (COA)

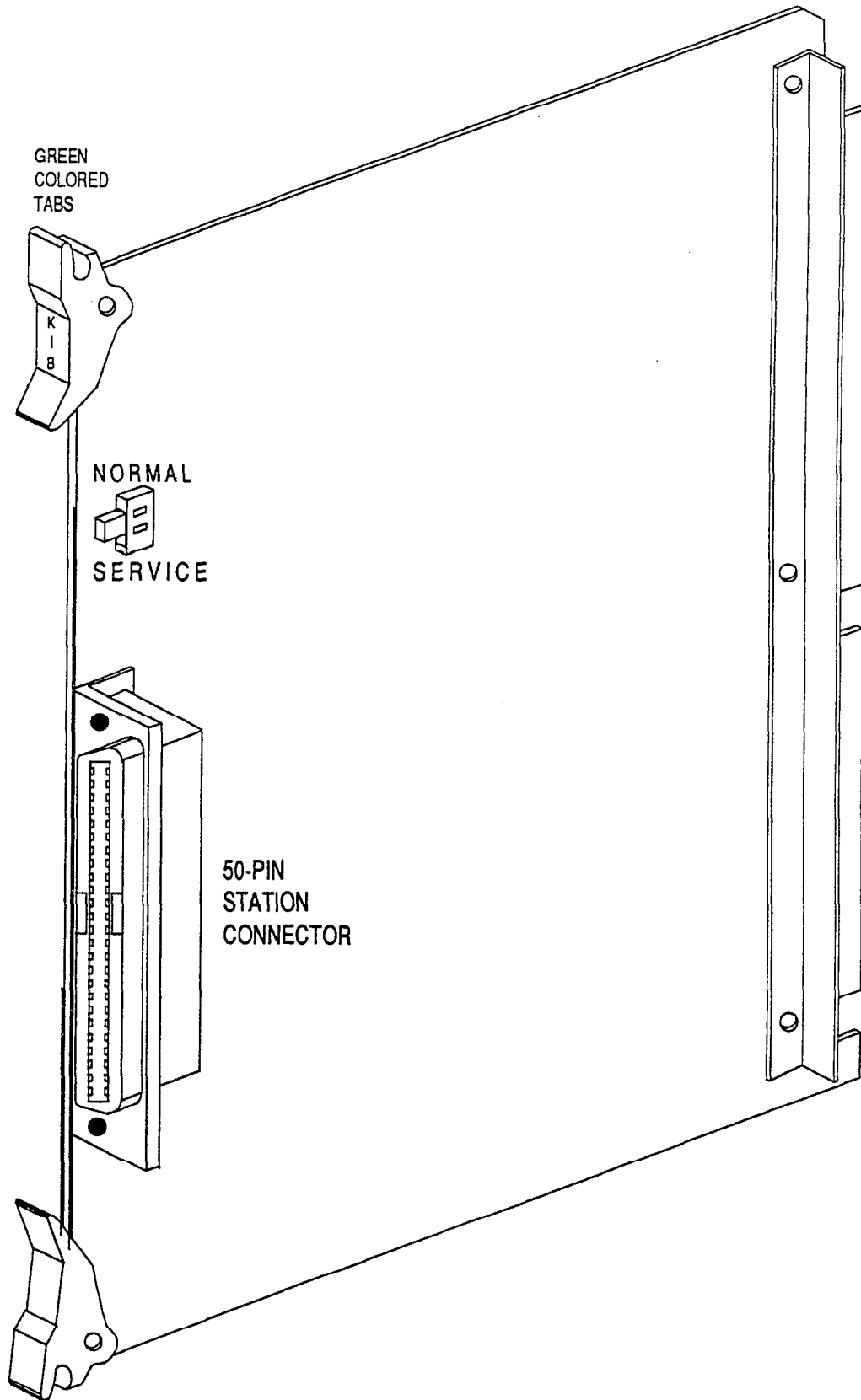

Figure 500-11 Key Station Interface Board (KIB)

Table 500-5 Station Connecting Block (KIB)

PAIR	PIN	COLOR	DESIG	DESCRP
1	26	WH/BL	VT 100	K I B
	1	BL/WH	VR 100	
2	27	WH/OR	DT 100	
	2	OR/WH	DR 100	
3	28	WH/GN	—	
	3	GN/WH	—	
4	29	WH/BN	VT 101	
	4	BN/WH	VR 101	
5	30	WH/SL	DT 101	
	5	SL/WH	DR 101	
6	31	RD/BL	—	
	6	BL/RD	—	
7	32	RD/OR	VT 102	
	7	OR/RD	VR 102	
8	33	RD/GN	DT 102	
	8	GN/RD	DR 102	
9	34	RD/BN	—	
	9	BN/RD	—	
10	35	RD/SL	VT 103	
	10	SL/RD	VR 103	
11	36	BK/BL	DT 103	
	11	BL/BK	DR 103	
12	37	BK/OR	—	
	12	OR/BK	—	
13	38	BK/GN	VT 104	
	13	GN/BK	VR 104	
14	39	BK/BN	DT 104	
	14	BN/BK	DR 104	
15	40	BK/SL	—	
	15	SL/BK	—	
16	41	YL/BL	VT 105	
	16	BL/YL	VR 105	
17	42	YL/OR	DT 105	
	17	OR/YL	DR 105	
18	43	YL/GN	—	
	18	GN/YL	—	
19	44	YL/BN	VT 106	
	19	BN/YL	VR 106	
20	45	YL/SL	DT 106	
	20	SL/YL	DR 106	
21	46	VI/BL	—	
	21	BL/VI	—	
22	47	VI/OR	VT 107	
	22	OR/VI	VR 107	
23	48	VI/GN	DT 107	
	23	GN/VI	DR 107	
24	49	VI/BN	—	
	24	BN/VI	—	
25	50	VI/SL	SPARE	
	25	SL/VI	SPARE	

Table 500-6 Power Failure Transfer Unit Connections(PFT)

PAIR	PIN	COLOR	DESIG	DESCRP
1	26	WH/BL	1TOT	P F T
	1	BL/WH	1TOR	
2	27	WH/OR	SPARE	
	2	OR/WH	SPARE	
3	28	WH/GN	1STIT	
	3	GN/WH	1STIR	
4	29	WH/BN	1STOT	
	4	BN/WH	1STOR	
5	30	WH/SL	2TOT	
	5	SL/WH	2TOR	
6	31	RD/BL	SPARE	
	6	BL/RD	SPARE	
7	32	RD/OR	2STIT	
	7	OR/RD	2STIR	
8	33	RD/GN	2STOT	
	8	GN/RD	2STOR	
9	34	RD/BN	3TOT	
	9	BN/RD	3TOR	
10	35	RD/SL	SPARE	
	10	SL/RD	SPARE	
11	36	BK/BL	3STIT	
	11	BL/BK	3STIR	
12	37	BK/OR	3STOT	
	12	OR/BK	3STOR	
13	38	BK/GN	4TOT	
	13	GN/BK	4TOR	
14	39	BK/BN	SPARE	
	14	BN/BK	SPARE	
15	40	BK/SL	4STIT	
	15	SL/BK	4STIR	
16	41	YL/BL	4STOT	
	16	BL/YL	4STOR	
17	42	YL/OR	5TOT	
	17	OR/YL	5TOR	
18	43	YL/GN	SPARE	
	18	GN/YL	SPARE	
19	44	YL/BN	5STIT	
	19	BN/YL	5STIR	
20	45	YL/SL	5STOT	
	20	SL/YL	5STOR	
21	46	VI/BL	6TOT	
	21	BL/VI	6TOR	
22	47	VI/OR	SPARE	
	22	OR/VI	SPARE	
23	48	VI/GN	6STIT	
	23	GN/VI	6STIR	
24	49	VI/BN	6STOT	
	24	BN/VI	6STOR	
25	50	VI/SL	——	
	25	SL/VI	——	

Table 500-7 Station Connecting Block (SLT)

PAIR	PIN	COLOR	DESIG	DESCRP
1	26	WH/BL	VT 100	S L T
	1	BL/WH	VR 100	
2	27	WH/OR	——	
	2	OR/WH	——	
3	28	WH/GN	——	
	3	GN/WH	——	
4	29	WH/BN	VT 101	
	4	BN/WH	VR 101	
5	30	WH/SL	——	
	5	SL/WH	——	
6	31	RD/BL	——	
	6	BL/RD	——	
7	32	RD/OR	VT 102	
	7	OR/RD	VR 102	
8	33	RD/GN	——	
	8	GN/RD	——	
9	34	RD/BN	——	
	9	BN/RD	——	
10	35	RD/SL	VT 103	
	10	SL/RD	VR 103	
11	36	BK/BL	——	
	11	BL/BK	——	
12	37	BK/OR	——	
	12	OR/BK	——	
13	38	BK/GN	VT 104	
	13	GN/BK	VR 104	
14	39	BK/BN	——	
	14	BN/BK	——	
15	40	BK/SL	——	
	15	SL/BK	——	
16	41	YL/BL	VT 105	
	16	BL/YL	VR 105	
17	42	YL/OR	——	
	17	OR/YL	——	
18	43	YL/GN	——	
	18	GN/YL	——	
19	44	YL/BN	VT 106	
	19	BN/YL	VR 106	
20	45	YL/SL	——	
	20	SL/YL	——	
21	46	VI/BL	——	
	21	BL/VI	——	
22	47	VI/OR	VT 107	
	22	OR/VI	VR 107	
23	48	VI/GN	——	
	23	GN/VI	——	
24	49	VI/BN	——	
	24	BN/VI	——	
25	50	VI/SL	——	
	25	SL/VI	——	

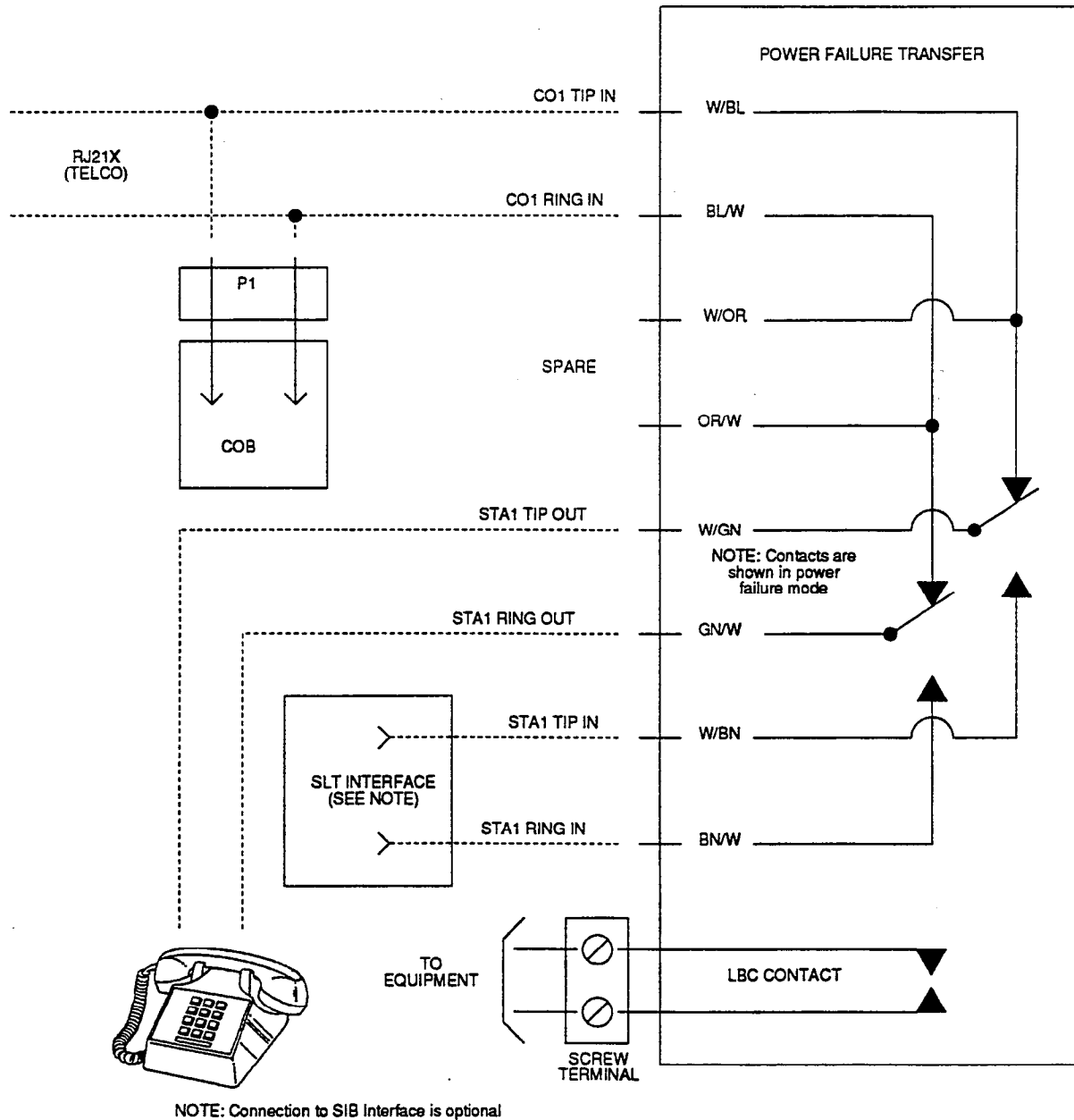

Figure 500-12 Power Failure Transfer Circuit (PFT)

- E. Connect the customer provided ringing generator and ringing devices(s) to the LBC contacts (Refer to Figure 500-12).
- F. Replace the plastic terminal strip protector.

500.14 KEY TELEPHONE INSTALLATION

A maximum of 96 Key Telephones may be installed with the Starplus 96EX Hybrid Key Telephone System (48 with the Basic KSU and 48 with the Expansion KSU). The Key Telephones are interfaced with KIB boards which each have eight circuits per board. Each KIB circuit interface is extended from the KSU to the MDF through the front edge connector on the KIB board.

Also at the MDF are the terminated distribution cables that are run from each Key Telephone location. Each Key Telephone requires two-pair twisted cable wiring to connect the Key Telephones to the System on a "home run" basis. The telephone end of the cable is terminated on a modular jack and the MDF end of the cable should terminate on a punchdown block making up the MDF. (Refer to Figure 500-13)

Cross connecting (jumper) wires connect the telephone to the KIB. Each key telephone is assigned a three-digit intercom directory number in accordance with the locations of the equipped KIB's.

The installer should exercise caution when connecting a Key Telephone while System power is on. The first pair of wires is reserved for voice transmission. The second pair supplies power and data. The data/power pair is overload protected by internal circuitry on the KIB card. The proper polarity of the wired connections must be maintained for proper operation.

500.15 DSS/DLS INSTALLATION

The DSS/DLS is assigned to operate with a Key Telephone. Up to three units can be assigned to a station. There is no limit to the number of units that can be installed in a System, but each unit uses a Key Telephone interface circuit and this reduces station capacity on a one-per-one basis.

A two-pair twisted cable is required for connecting the DSS unit. The cable should be placed from the DSS to the MDF in a "home run" manner. The DSS end of the cable is terminated on a three-pair modular jack and the MDF is "punched down" on a terminal block for cross connection to the appropriate station cable (Refer to Figure 500-13 and Table 500-5).

Since the System supplies power to the DSS, no transformer or external power device is required.

500.16 PHONE BOX INSTALLATION

The 96EX Phone Box can make calls to preassigned stations as well as receive intercom calls. The unit should be located in weather protected areas where paging or monitoring is required.

The Phone Box consists of a top housing and bottom mounting plate. The top housing has a speaker, microphone, wire terminals and electronic circuitry. The housings are separated by inserting a thin, flat-edged tool at the bottom rim of the assembly. By pressing inward on the recessed retaining tab, the assembly will open.

The connection of the Phone Box(es) to the KSU is identical to that of the key telephone. Refer to Figure 500.13

The bottom plate of the Phone Box assembly is fastened to the wall by mounting with customer supplied No. 8 or larger pan head screws. The cable is routed through the cable-entry holes provided on the bottom plate and is connected to the screw terminal strip on the upper housing. Four (4) screw terminals are identified by wire color on the silk-screened printed circuit board to correspond with the wiring sequence at the punchdown connector at the MDF.

The slack wiring should be pulled back through the bottom mounting plate and the top housing snapped shut.

500.17 SINGLE LINE TELEPHONE INSTALLATION

Single Line Telephones (SLT's) can be exchanged for Key Telephones on an eight-for-eight basis. The following items are required for a System installing SLT's:

- 1 SIB board (installed in KSU)(supports 8 SLT's)
- 1 RG unit (installed into EPH2 Housing)
- 1 APL board (installed in Basic KSU)

The SIB is color coded with green ejector tabs and is plugged into any designated KIB card slot. Each SIB board supports eight telephones (standard DTMF Single Line Telephones and message waiting DTMF SLT's). The Ring Generator Unit (RG) must be installed into the External Power Supply Housing 2 (EPH2) to provide power for ringing and message waiting for SIB's (Refer to Figure 500-4). When the number of SIB's installed exceeds the traffic handling of the two DTMF receivers, the SLU module should be installed. The Single Line Telephone DTMFRS (Receiver/Sender) Unit (SLU) installs on the Application Board (APL) and provides four additional DTMF receivers and one additional DTMF sender to support Single Line Telephones.

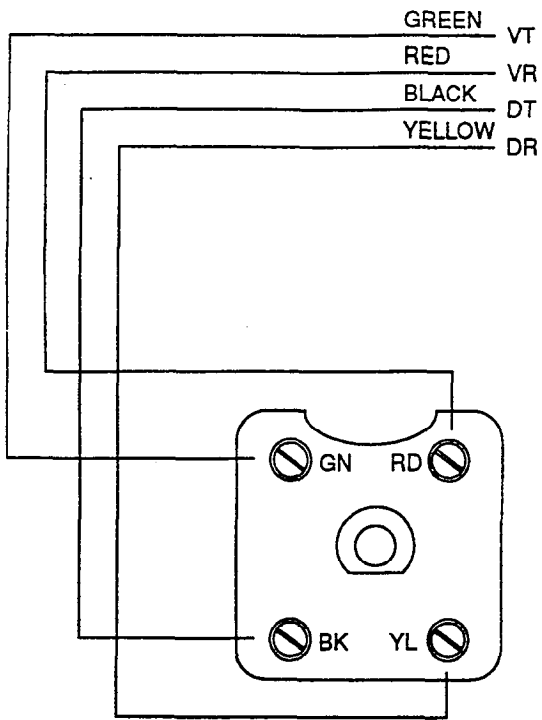

Key Telephone Wiring

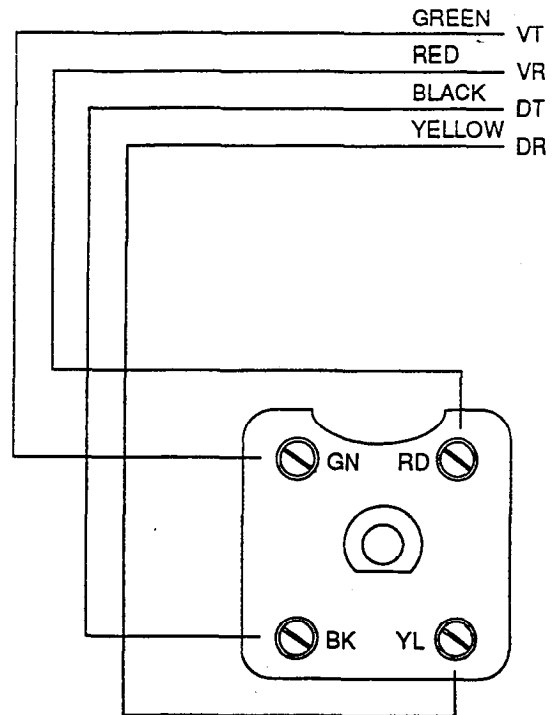

DSS/DLS Console Wiring

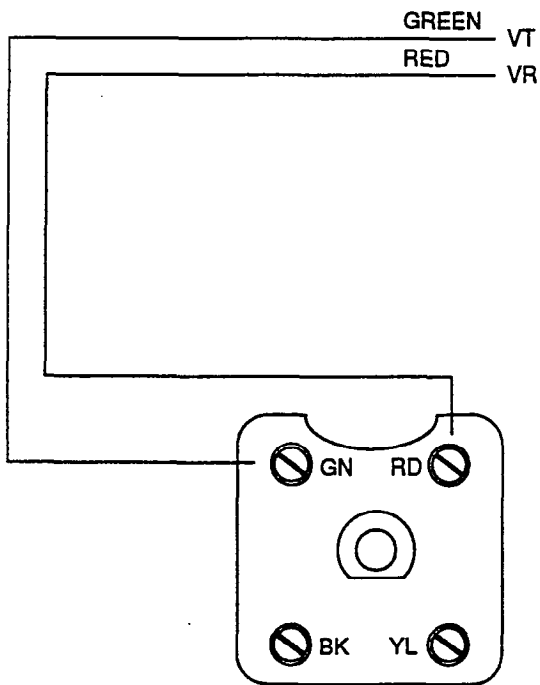

Single Line Telephone Wiring

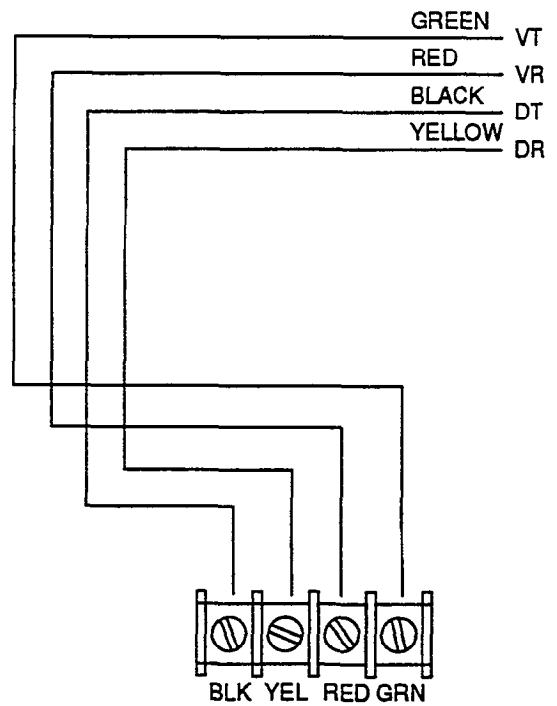

Phone Box Wiring

Figure 500-13 Station Modular Block Wiring

Each SLT requires one-pair cable. The cable should be placed from the telephone location to the MDF in a "home run" manner. The telephone end of the cable run should be terminated in a modular jack (Refer to Figure 500-13). The MDF end should be "punched down" on a terminal block for cross connection to the appropriate station cable (Refer to Table 500-7).

500.18 OFF-PREMISE EXTENSION INSTALLATION (OPX)

The OPX board can be installed in all but the first KIB card slot of the System. It can be inserted and removed with power on using the "Normal/Service" switch on its top front edge. It also has an adjustable control directly above the "Normal/Service" switch. This control is set at the factory for proper operation; **DO NOT** make adjustment to this control.

One (1) Single Line Ring Generator and M/W Power Supply Unit (RG) and one (1) Application Board (APL) are necessary to support the OPX card. An additional Single Line DTMFRS Unit (SLU) may also be needed if the combined traffic of OPX, SLT, and DISA calls affects the availability of receiver circuits.

A 50-pin amphenol type female connector is provided on the front edge of the OPX. This allows the OPX System extensions to be cabled to the Main Distribution Frame (MDF). Twenty-five pair cabling

must be prepared with a male connector to extend the OPX extension to the MDF. The cable should be routed through the bottom cable access area of the KSU or Expansion cabinet. The cable(s) then should be terminated on industry standard 66M1-50 punch-down connector block(s). After the amphenol type cable connector has been attached, the cable should be secured to a cable clamp at the bottom of the KSU or Expansion cabinet

Connection from the OPX punch-down block to an FCC approved RJ21X connector can be done by cross-connect wiring. Refer to Table 500-8 for pair identification for each of the OPX circuits.

Each OPX port requires an OL13C network circuit. An FCC registered interface, such as RJ21X is required to connect to the public network. Only SLT devices capable of sending true DTMF can be used on an OPX circuit provided by the system. When an OPX board is installed, four station ports are rendered unusable, reducing the maximum number of station in the system by four. For example, with an OPX board inserted into the second KIB card slot extensions 108 through 111 support OPX circuits (extensions 112 through 115 are not usable).

500.19 WALL MOUNTING THE TELEPHONE

All connections to the Key Telephone are fully modular. To wall mount the Key Telephone, it is necessary to have one Wall Mount Kit and one standard-type jack assembly designed for normal wall hanging applications.

- A. Unplug the line cord from the phone. This line cord will not be required and should be retained as a maintenance replacement item.
- B. Lift the plastic number retainer upward and expose the screw underneath. Remove the screw and the handset tab. Replace it with the handset tab from the Wall Mount Kit.
- C. Be careful to position the tab so that the protrusion faces the hookswitch. This will allow the handset to remain secure when the telephone is on the wall. Replace the screw and snap the number retainer into place.
- D. Substitute the short modular cord from the Wall Mount Assembly into the modular connector vacated by the line cord.
- E. Align the wall mount baseplate with holes on the bottom of the telephone. Snap in place.
- F. Now match the two key hole slots on the baseplate with the lugs on the 630-A type jack. Align the modular connector and slide telephone into place (Refer to Figure 500-14).

Table 500-8 OPX Station Connecting Block (OPX)

PAIR	PIN	COLOR	DESIG	DESCRP
1	26	WH/BL	T1	O P X
	1	BL/WH	R1	
2	27	WH/OR	UNUSED	
	2	OR/WH	UNUSED	
3	28	WH/GN	UNUSED	
	3	GN/WH	UNUSED	
4	29	WH/BN	T2	
	4	BN/WH	R2	
5	30	WH/SL	UNUSED	
	5	SL/WH	UNUSED	
6	31	RD/BL	UNUSED	
	6	BL/RD	UNUSED	
7	32	RD/OR	T3	
	7	OR/RD	R3	
8	33	RD/GN	UNUSED	
	8	GN/RD	UNUSED	
9	34	RD/BN	UNUSED	
	9	BN/RD	UNUSED	
10	35	RD/SL	T4	
	10	SL/RD	R4	

NOTE: PAIRS 11 THROUGH 25 UNUSED

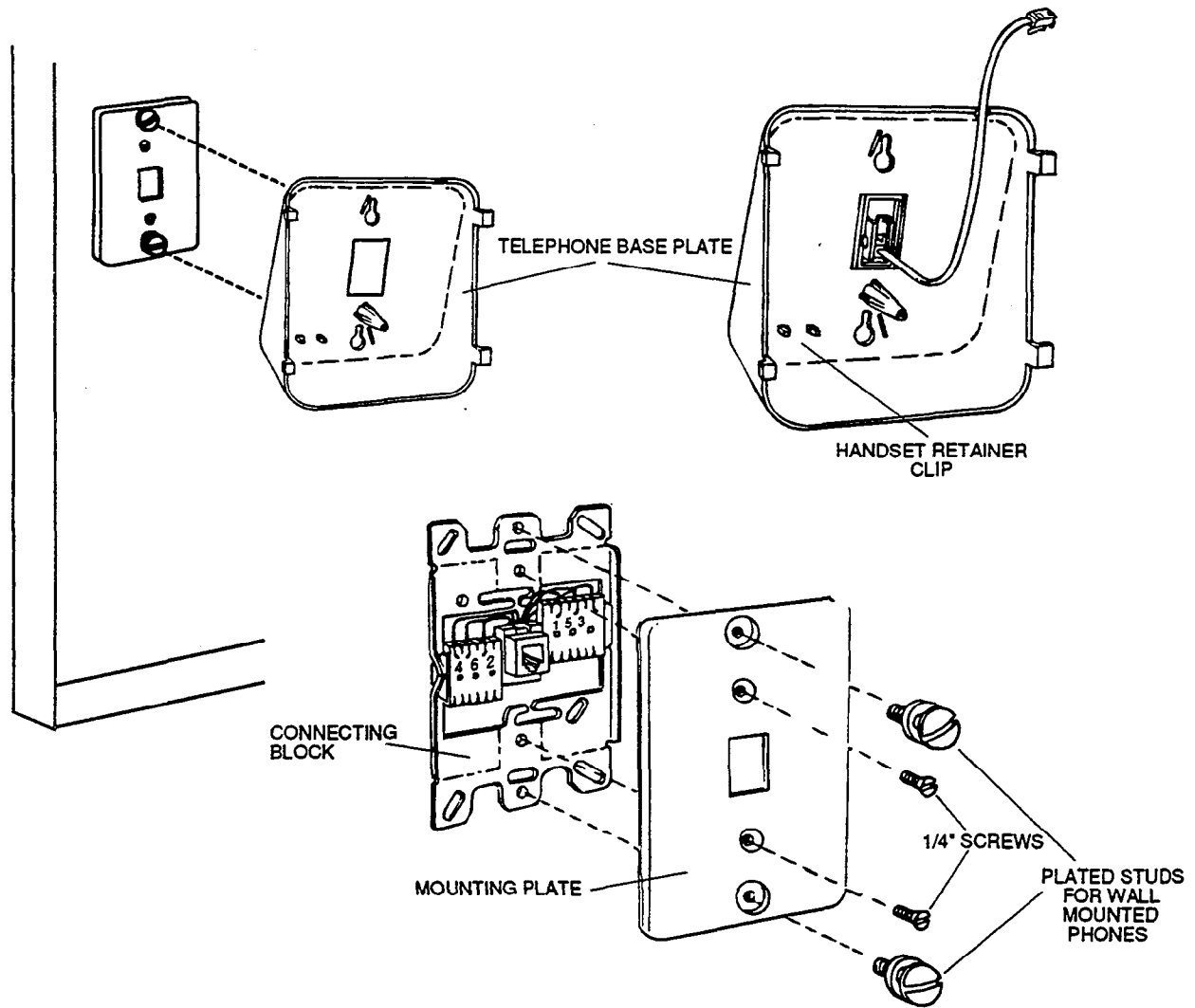

Figure 500-14 SP 96EX Key Telephone Wall Mounting

500.20 HEADSET INSTALLATION

The Starplus 96EX Key Telephones have been designed to operate with industry standard electret mic compatible modular headset adapters and operator headsets. To modify a Starplus Key Telephone to support an external headset, plug the headset adapter cord into the vacant handset jack on the Key Telephone base. Plug the telephone handset cord into the headset adapter box where indicated by the headset manufacturer's instructions.

In the programming section, under Station Programming, it is necessary to enable headset operation. The station will then have the capability to enable or disable headset mode by dialing a code. When Headset mode is active at the station, the ON/OFF button then controls the on-hook or off-hook status. Additionally, while headset mode is active such features as On-Hook Dialing and Handsfree Speakerphone operation become inoperable.

500.21 APPLICATION BOARD (APL) CONNECTIONS

A. External Paging Connections

External paging amplifier equipment (customer provided) may be connected to the System for dial access from any telephone in the System (except those denied paging access). One non-amplified external paging zone is provided with the APL board. The output impedance of the paging zone is 600 ohms at 0 dBm. The low level voice signal output is specified at 5 milliwatts maximum. Two sets of dry control contacts are provided to switch on the external amplifier equipment and/or to momentarily remove background music if supplied to the paging device. Connection is made on the APL board. (Refer to Figures 500-15, 500-16, and 500-17)

The voice output is provided on the EPT and EPR pair. The break contacts are pair EPB and the make contacts are pair EPM.

B. Installing Recorded Announcement

The Recorded Announcement feature (RAN) is used with the Uniform Call Distribution feature (UCD) to provide unanswered incoming CO calls or calls in queue with a Recorded Announcement while waiting for an available UCD station. The System may be programmed to provide this announcement on specified RAN output ports on the System (unused SLT and COB ports, and the APL RAN port). The System can be programmed to connect the waiting caller to a different RAN port for the second, and subsequent RAN messages.

Connections made on the MOD 3 modular jack of the Applications Board (APL) for E&M type of signaling, refer to Figures 500-15, 500-16, and 500-17. The VT and VR pair are for connection to the cus-

tomers supplied Recorded Announcement device. CTLT and CTRL pair are the control contacts that provide closure (momentary) when a call is connected to the RAN voice pair (VT, VR). The Sense leads are used by the 96EX system to detect contact closure provided by RAN device when the message is completed.

When a CO line port is used for a ground start application, a 24V dc power source must be connected to the CO line port for talk battery. A Loud Bell Control contact assigned to that CO line port in programming would provide contact closure to start the Recorded Announcement device. (Refer to Figure 500-18)

When an SLT port is used, the RAN device must be configured for ring trip operation (loop start). The 90V ac voltage sent to the SLT port will be recognized by the RAN device which will then answer the call. (Refer to Figure 500-18)

500.22 INSTALLING THE SINGLE LINE TELEPHONE DTMFRS UNIT (SLU)

The two DTMF receivers and two DTMF senders located on the APL board are sufficient to support up to 16 Single Line Telephones under moderate SLT usage. If more than 16 SLT's are installed, or SLT usage is heavy, then the SLU should be added to provide four additional DTMF receivers and one additional DTMF sender. It is also recommended that the SLU be installed when a Voice Mail or Auto Attendant system is connected to the 96EX system.

- A. Remove the Application Board (APL) from the BKSU.
- B. Locate the K1 and K2 connectors on the Application Board (Refer to Figure 500-15) and the K1 and K2 connectors on the SLU.
- C. Take the SLU and push the K1 pin connector gently onto the K1 pins on the APL board.
- D. Then push the K2 pin connector on the SLU gently onto the K2 pins on the APL board.

The Receiver/Sender Unit is now installed and the APL board can be replaced in the BKSU.

500.23 INSTALLING THE RSM (Additional RS-232C port)

- A. Remove the Application Board (APL) from the BKSU.
- B. Set the RSM baud rate (Refer to Figure 500-15).
- C. Remove the screws from the APL board.
- D. Locate the S1 connector on the APL board and the S1 pins on the RSM unit.
- E. Gently push the S1 pins on the RSM onto the S1 pin connector on the APL board.
- F. Secure with the screws removed in step c.

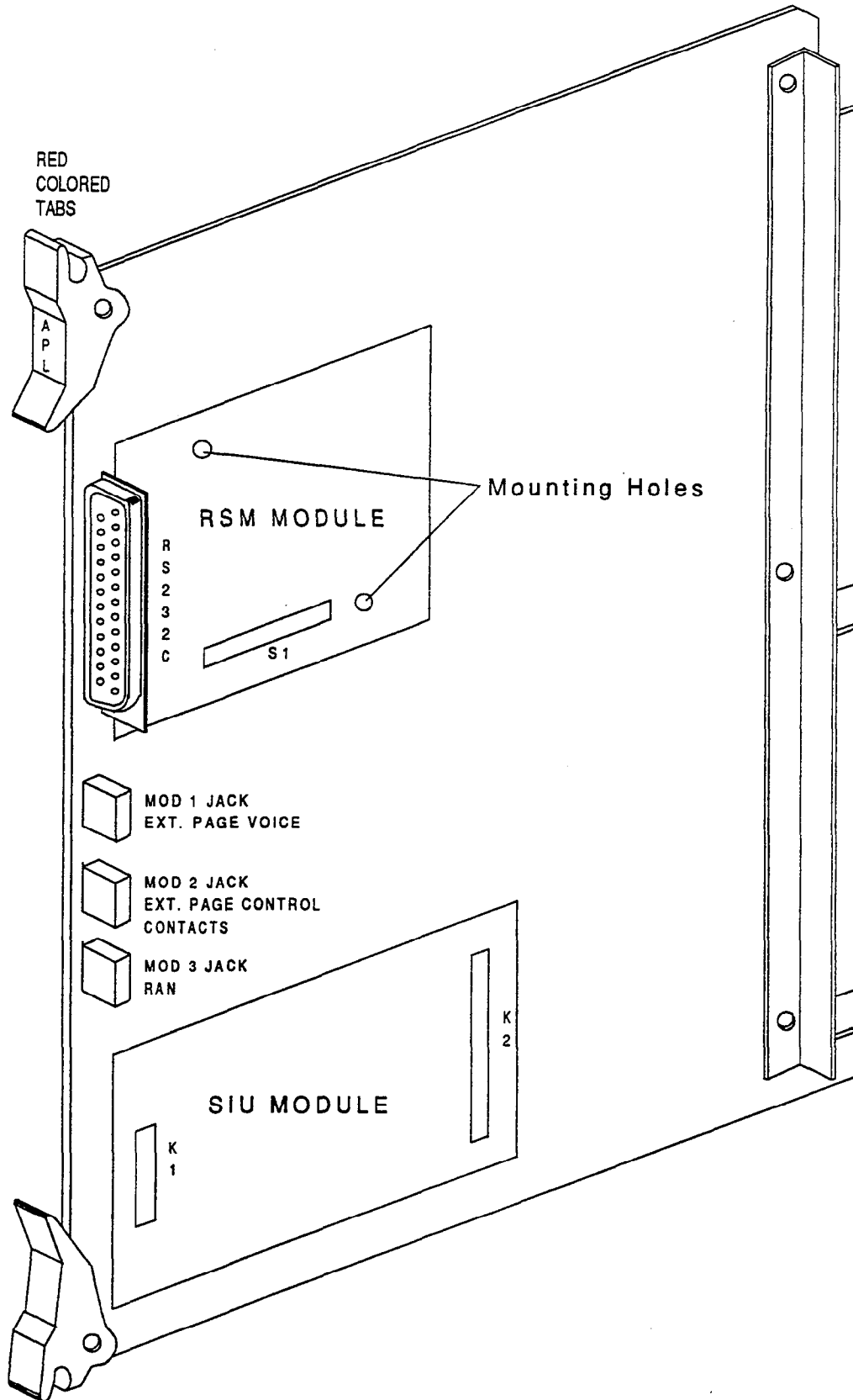

Figure 500-15 Application Board (APL)

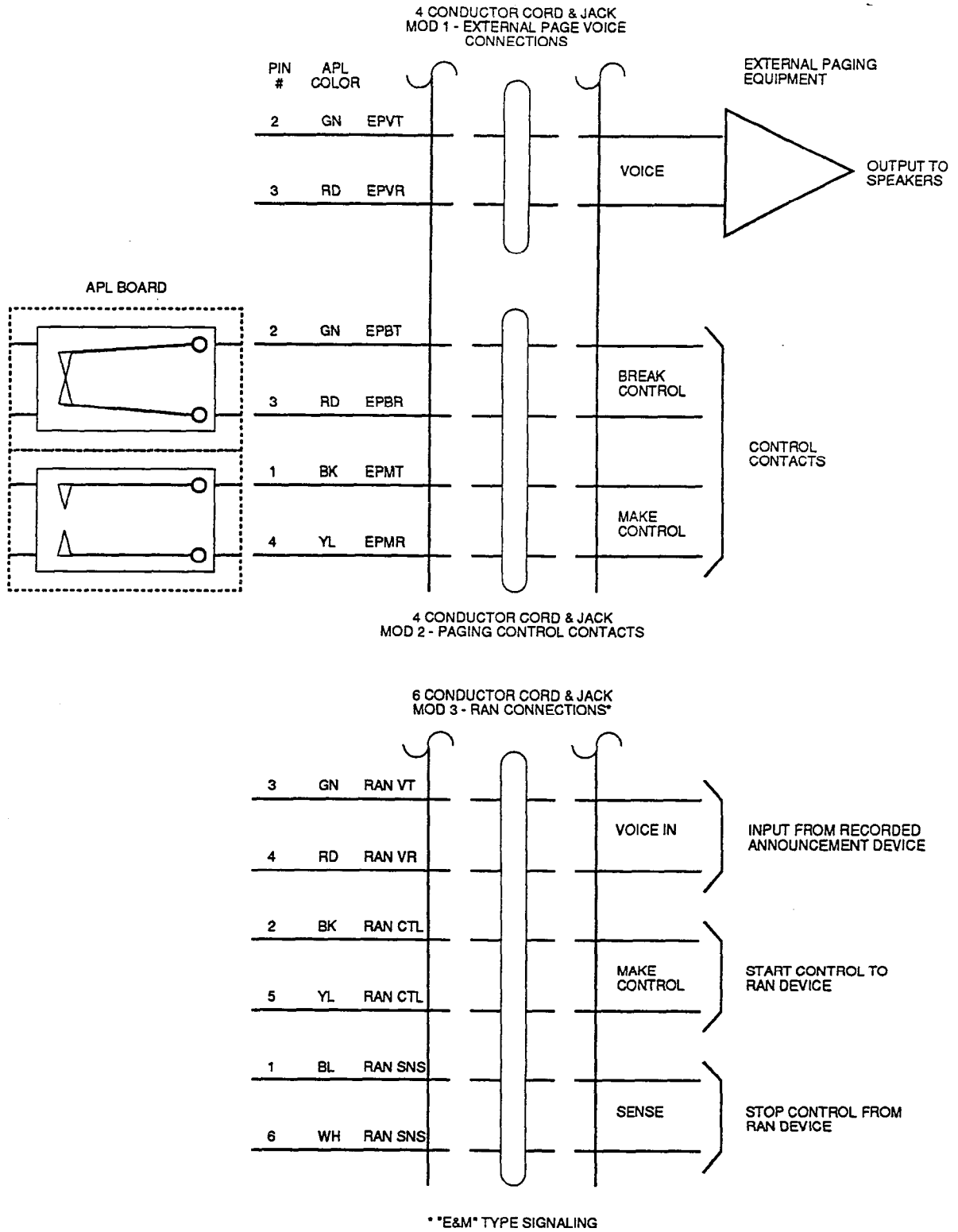

Figure 500-16 Application Board Connections

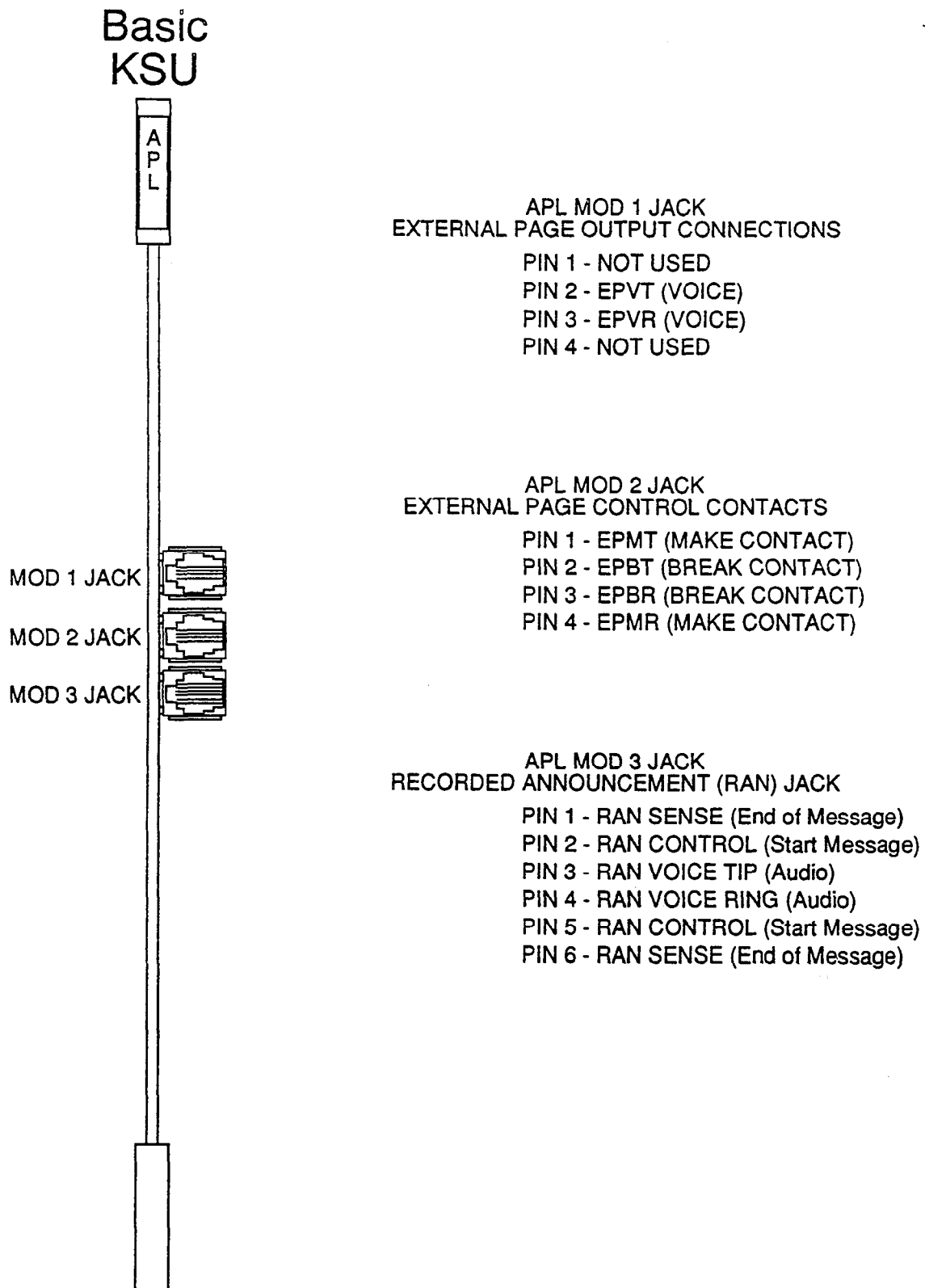

Figure 500-17 Application Board Modular Connections

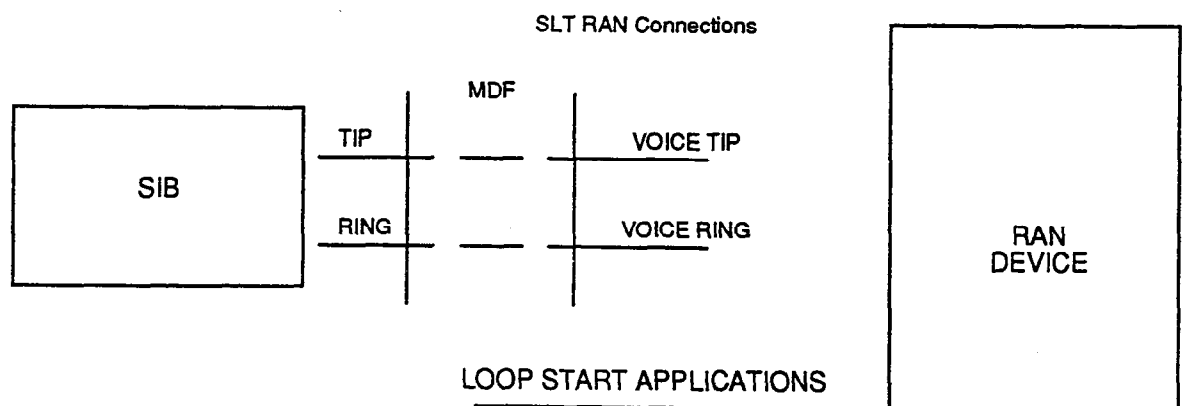
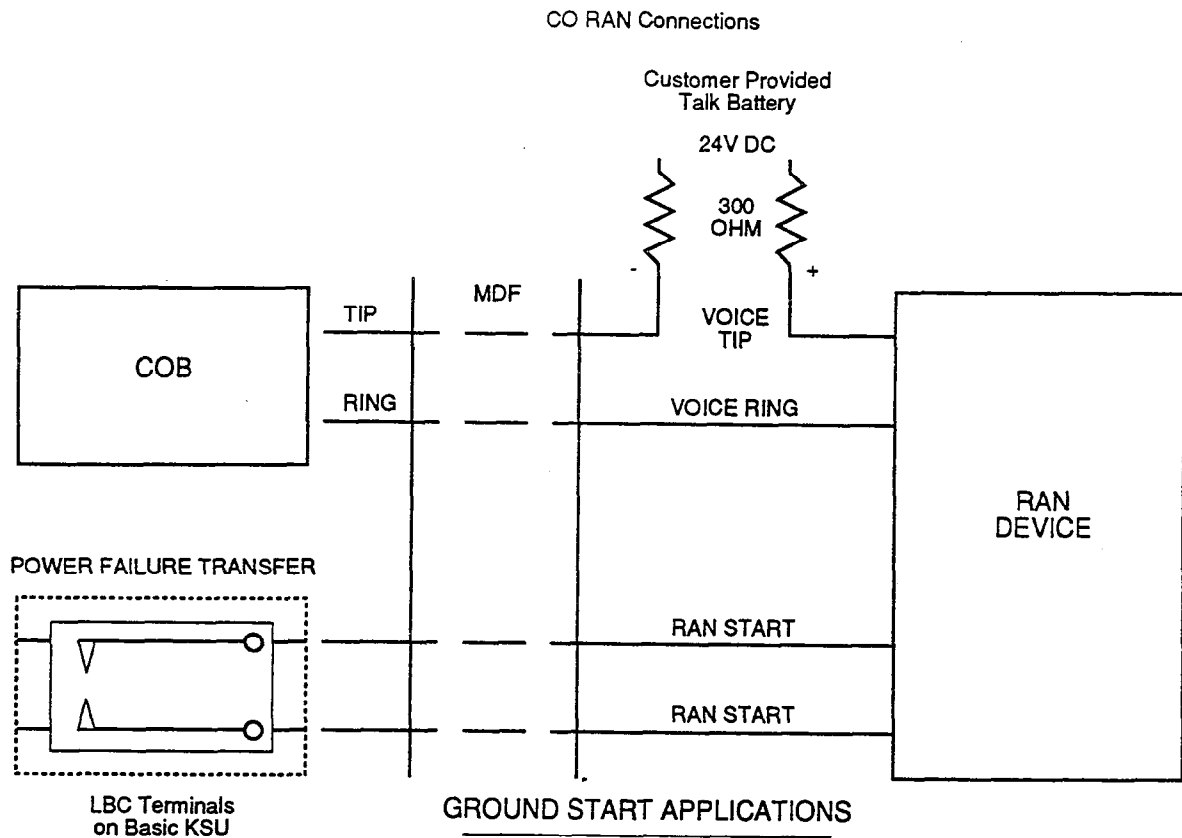

Figure 500-18 CO and SLT RAN Connections

- G. Re-insert the APL board in the BKSU.
- H. Set switch seven on the CPB to the APL (ON) position.

500.24 RS-232C CONNECTIONS

One RS-232C type connector is provided and is located on the CPB board. There is an optional second RS-232C connector which can be installed on the APL board. The RS-232C connector on the CPB can be used for either Station Message Detail Recording (SMDR) or for on-line (Remote) database programming through the RS-232C port using a data terminal. If the second RS-232C connector is installed on the APL board, this connector can be used for SMDR only. The RS-232C pinout is shown in Figure 500-20.

Either an 80 character or 29 character printing device may be connected to the RS-232C connector. Switch 6 on the CPB board must be programmed to provide either the desired 29 or 80 character display field and Switch 2 must be set in the on position to enable CTS signal. (Refer to Section 8 for further details on the CPB switch settings)

500.25 BACKGROUND MUSIC AND MUSIC-ON-HOLD

Music-On-Hold and Background Music through Key Telephone speakers can be provided via a customer provided tuner, tape deck, etc. Connection is made with an RCA jack connector on the DC/DC Converter (DCU); a volume adjustment is also provided on the DCU (Refer to Figure 500-7). The input impedance of the music source is 2K ohms maximum.

500.26 RING GENERATOR AND MESSAGE WAITING POWER SUPPLY UNIT

When the Starplus 96EX System is equipped with single line telephones, a Single Line Ring Generator and Message Wait Power Supply Unit (RG) is needed to provide ringing and power for message waiting SLT's. The RG is mounted inside the External Power Supply Housing 2 (EPH2) on the bottom shelf. Insert the RG with components facing right and secure with the screw. (Refer to Figure 500-4).

500.27 INSTALLING THE EXPANSION KSU

NOTE: The second Power Supply (PS) must be added to the External Power Supply Housing 2 (EPH2) when the Expansion KSU is added.

The Expansion KSU can be installed at the same time as the Basic KSU, or later. In either case the system power must be turned off prior to the installation.

- A. Refer to Section 500-3 - KSU Mounting. The Expansion KSU mounts directly to the right of the Basic KSU (Refer to Figure 500-1). Using

the template provided, identify the screw hole locations. Insert the two screws into the wooden backboard and tighten enough to hold the weight of the unit.

- B. Remove the connector cover on the right side of the Basic KSU (Refer to Figure 500-3). Remove the last three cards on the right side of the Basic KSU.
- C. Secure the two cabinets together by hooking the mounting brackets on the left side of the Expansion KSU over the ones on the right side of the Basic KSU and at the same time position the Expansion KSU on the two screws inserted in Step a above. Tighten the screws on the right side of the Expansion KSU.
- D. Connect the ground of the Basic KSU to the ground of the Expansion KSU with a no. 8 or larger gauge wire.
- E. Feed the three ribbon cables through the slot created by removing the side cover and plug them into the Basic KSU (Refer to Figure 500-21).
- F. Take the power cable located in the Expansion KSU and feed it through the slot in the Basic KSU and plug it in. Then take the ribbon cable previously connected to the Basic KSU and connect it to the Expansion KSU.

Installation of the Expansion KSU is now complete. Replace PCB's removed in step B. above. Power may also be restored.

RSM Module Switch Settings

Switch Settings				
Baud Rate	1	2	3	4
300	o	x	x	x
1200	x	o	x	x
2400	x	x	o	x
4800	x	x	x	o

O=ON; X=OFF

Equipment Needed:
1 Phillips Screwdriver

Two screws with washers are used to mount the RSM Module to the Applications Board (APL).

RS-232C Module (RSM)

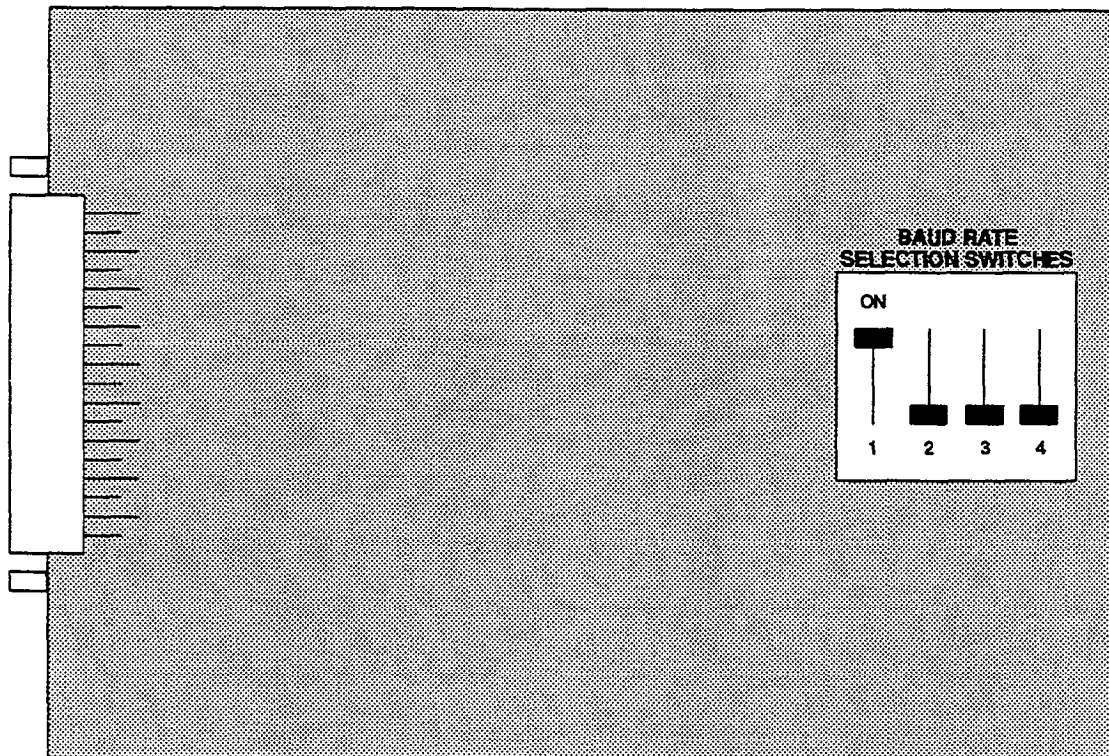
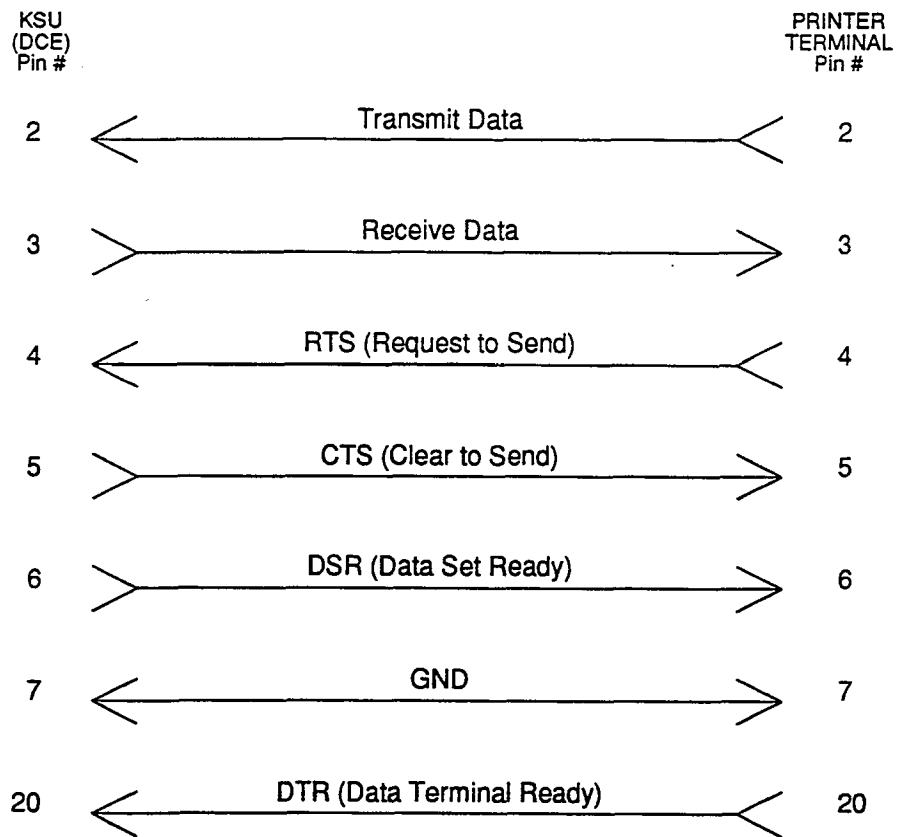

Figure 500-19 RSM Baud Rate Selection



RS-232C PINOUT
Data Communication Requirements are:
A) Serial Port Compatible
B) ASCII Code Compatible
C) 8 Data Bits and 1 Stop Bit
D) No Parity

Figure 500-20 RS-232C Connections

Table 500-9 SMDR Printout

The SMDR feature provides detailed records of all outgoing and/or incoming, long distance only or all calls exceeding 30 seconds. This feature is enabled or disabled in system programming. By default, SMDR is not enabled and is set to record long distance calls only. A printout format of 80 characters maximum or 29 character maximum may be selected in system programming. The standard format is 69 characters on a single line. A 29 character format will generate 3 lines per message. If the SMDR feature is enabled, the system starts collecting information about the call as soon as it starts and terminates when the call ends. If the call was longer than 30 seconds, the following information is printed:

29 character format selected

```
116 08 00:02 14:13 05/11/90
012145678901
123456789012
```

```
AAA BB HH:MM HH:MM MM/DD/YY (CR)(LF)
HCCCCCCCCCCCCCCCCCCCCCCCC (CR)(LF)
GGGGGGGGGGGG (CR)(LF)
```

80 character format selected

STA	CO	TOTAL	START	DATE	DIALED	ACCOUNT CODE
116	08	00:02	14:13	05/11/90	012145678901	123456789012

```
AAA BB HH:MM HH:MM MM/DD/YY HCCCCCCCCCCCCCCCCCCCCCCCC GGGGGGGGGGGGG (CR)(LF)
```

AAA = Station originator or Trunk on DISA and Off-Net (CO Line) calls. (300=APL RAN port)

BB = Outside line number

HH:MM = Duration of call in Hours and Minutes

HH:MM = Time of day (start time) in Hours and Minutes

MM/DD/YY = Date of Call

H = Indicates call type

“I” = Incoming

“O” = Outgoing

“T” = Transferred

CC....CC = Number dialed

GG....GG = Last Account code entered (optional)

(CR) = Carriage return

(LF) = Line Feed

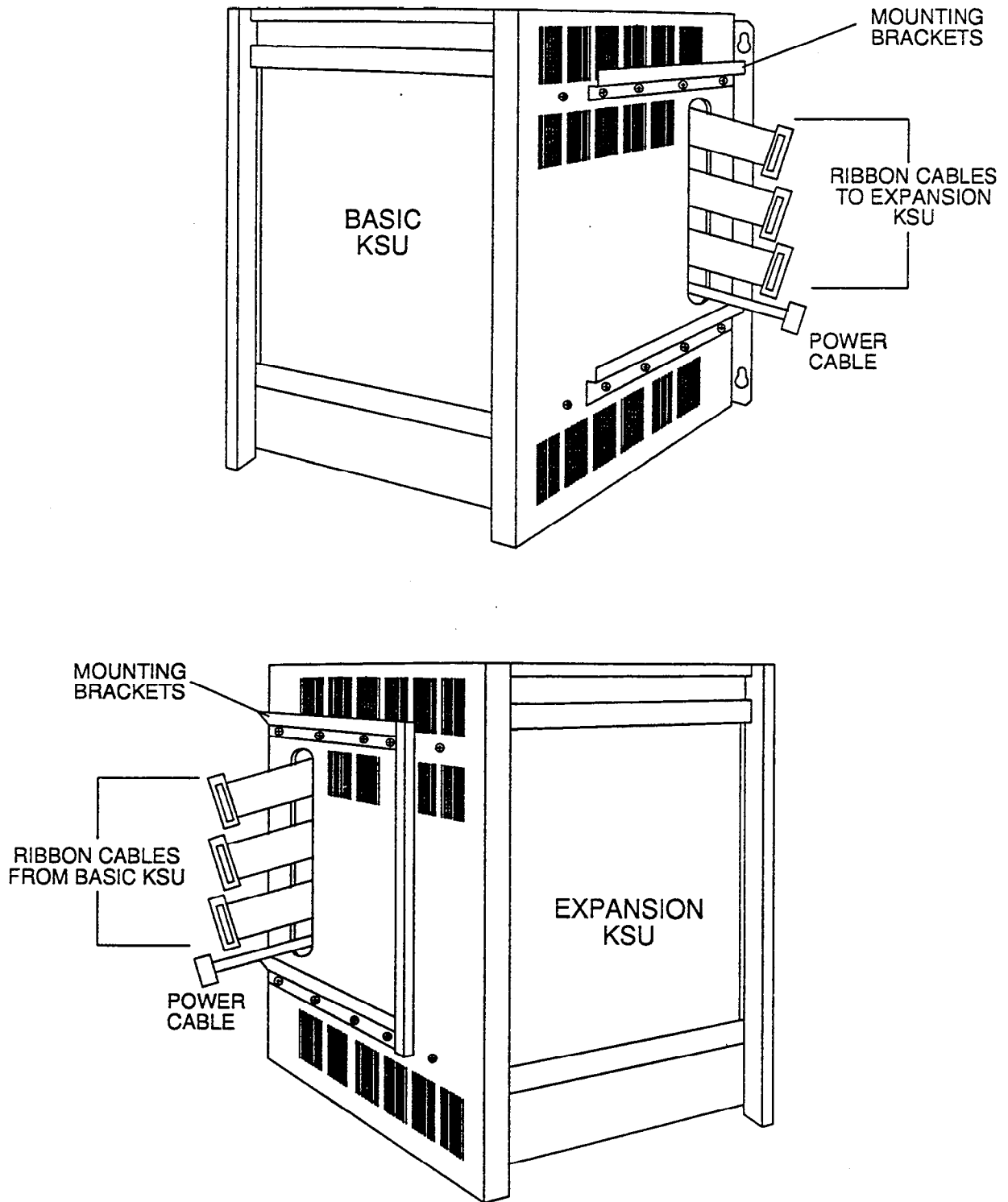

Figure 500-21 Installing the Expansion KSU

SECTION 600

CUSTOMER DATA BASE PROGRAMMING

600.1 INTRODUCTION

The Starplus 96EX Key Telephone System can be programmed to meet each customer's individual needs. All programming is done at station 100 using the Enhanced or Executive model Key Telephone as the programming instrument. The Executive model is suggested since the display is designed to assist in programming.

When the program mode is entered, the Key Telephone being used no longer operates as a telephone but as a programming instrument with all of the buttons redefined. The keys of the dial pad are used to enter data fields (Program Codes) associated with system, station, and CO line features as well as enter specific data that requires a numeric entry. Flexible buttons are used to toggle on or off features or allow entry into specific data fields. LED's and the LCD display provide visual indication of entered data and their value.

Programming can also be performed by using an ASCII terminal, or a computer capable of emulating an ASCII terminal. This form of programming can be done either locally (on-site) by connecting the terminal directly to the RS232C connector or the CPB or can be performed remotely (off-site) by connecting a modem to the RS232C on the CPB. The method and steps to program the system via a terminal are identifiable to that use when programming from a key set. A button to keyboard mapping has been incorporated (see Figure 600-1) to help minimize familiarization and training time.

At the time the system is installed it must be initialized to load default data into memory. If this pre-programming suits the customer, initialization is all that is needed. Refer to Table 600-1 for a listing of all the default values.

Any time data is to be changed, the program mode must be entered and then the individual data field (program code). A data field can be entered to determine current programming or to change a specific feature within that field.

During programming, the other Key Telephones in the System operate normally. If a data field is entered but nothing is changed, or changed but not entered, the previous data will remain intact upon leaving that data field. Data fields can be entered at random.

In many of the data fields, programming is performed by toggling LED's on or off, or entering digits on the keypad. If no changes are to be made to the line or

station, exit the data field by either leaving the program mode (pressing the ON/OFF button to OFF) or entering another data field (pressing the FLASH button and entering that program code).

When features are being programmed, tones are provided to help the programmer determine if a correct or incorrect entry has been made. A solid one second tone indicates the data was accepted. An interrupted tone means an error was made.

When this occurs, re-enter the data field and re-enter the information. Until new data is entered and accepted, the system will continue to operate under default or previously entered values.

The system database is updated on a real-time basis as new data is entered, by pressing the Hold button. The system continues to operate with the current data base and is updated with any newly entered or changed data without interruption to telephone operation or call processing in progress. However, if for example a station's attributes are changed while that station is off-hook on an active call, the newly entered data will not take effect until the station goes on-hook or becomes idle.

NOTE: Some features must have more than one data field programmed for that feature to work. Where this is the case, it will be stated in the instructions.

600.2 PROGRAM MODE ENTRY (Data Terminal)

A data terminal connected to the RS-232C port on the CPB can be used for data base programming. When using a data terminal (I/O device) to program the System, press return (enter) on the terminal, enter the password [SMOKIE], and press return again. Proceed with programming referring to Figure 600-1 for terminal characters that represent the key-set buttons. By entering a [?] from the terminal, a HELP screen will appear, similar to that shown in Figure 600-1.

Using the Remote Admin Key Definitions follow the same steps and procedures to program the 96EX when using a terminal (as outlined in the following sections).

When using a data terminal (I/O device) to program the system, the following chart presents the data terminal characters that are equivalent to the keyset buttons.

adm>?			
REMOTE ADMIN KEY DEFINITIONS			
Keyset	Terminal	Keyset	Terminal

HOLD	ENTER/CR	FLEX 1	Q
FLASH	,	FLEX 2	W
0	0	FLEX 3	E
1	1	FLEX 4	R
2	2	FLEX 5	A
3	3	FLEX 6	S
4	4	FLEX 7	D
5	5	FLEX 8	F
6	6	FLEX 9	Z
7	7	FLEX 10	X
8	8	FLEX 11	C
9	9	FLEX 12	V
10	10	FLEX 13	Y
11	11	FLEX 14	U
*	*	SPEED	O
#	#	TRANS	T
enable	+	CALLBACK	K
disable	-	DND	L
		ON-HOOK	M
adm>			

In place of keyset button toggling to enable/disable a feature, the associated data terminal key can be toggled (pressed again) to enable/disable a feature.

Figure 600-1 Data Terminal Program Codes Cross Reference

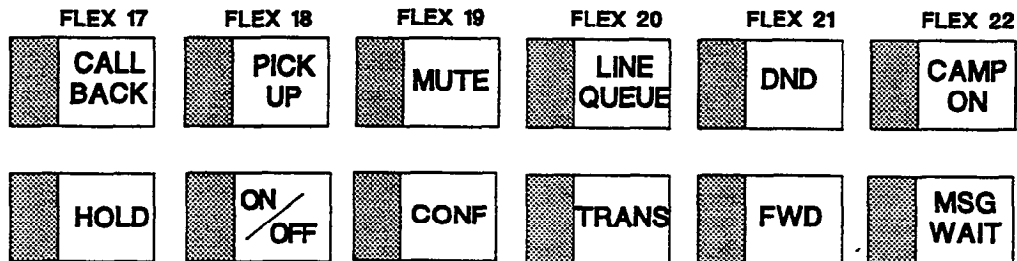
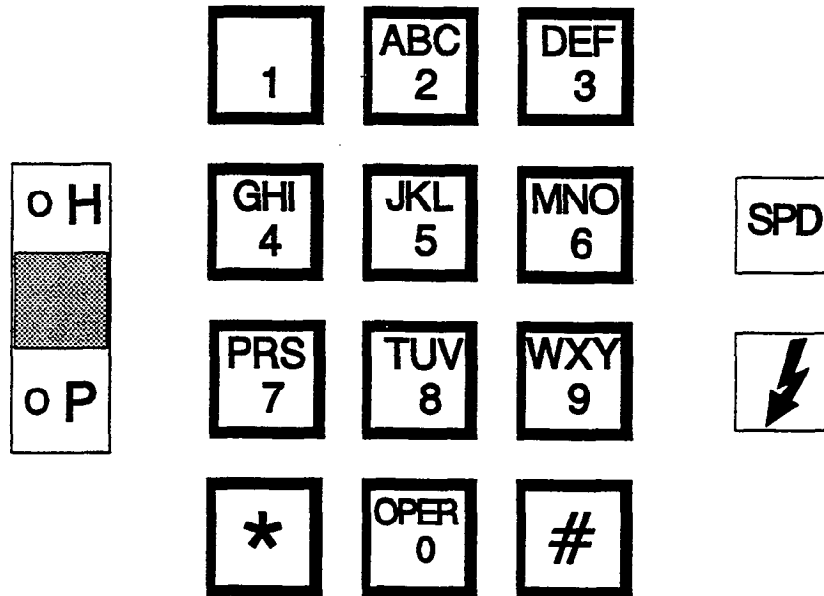
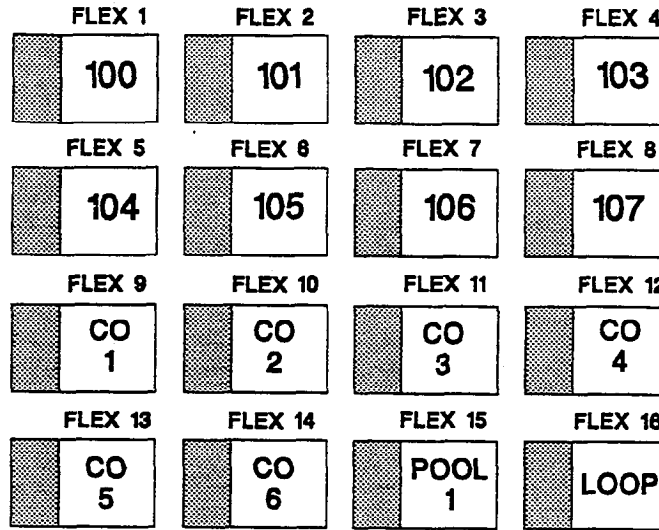

Figure 600-2 SP 96EX Default Button Mapping

Table 600-1 Default Values

FEATURE	PROGRAM CODE	FLEX BUTTON	DEFAULT VALUE
System Hold Recall Timer	Flash 01		060 sec.
Exclusive Hold Recall Timer	Flash 02		180 sec.
Transfer Recall Timer	Flash 03		045 sec.
Preset Forward Timer	Flash 04		10 sec.
Pause Timer	Flash 05		2 sec.
Call Park Timer	Flash 06		180 sec.
Conference Timer	Flash 07		10 min.
MSG Wait Reminder Tone	Flash 08		000 min.
Paging Timeout Timer	Flash 09		15 sec.
CO Ring Detect Timer	Flash 10		3 (100 msec.)
Hold Preference	Flash 11		System
Automatic Privacy	Flash 12		Yes
Executive Override Warning Tone	Flash 12		Yes
External Night Ring - LBC1	Flash 13		No
Attendant Override	Flash 14		No
Attendant Station Assignment	Flash 15		100
Loud Bell Control	Flash 16		None
PBX Dialing Codes	Flash 17		None
Executive/Secretary Transfer	Flash 18	Buttons 1-4	None
UCD Groups	Flash 19	Buttons 1-8	None
SMDR (ON/OFF)	Flash 20	Button 1	Off
Call Type		Button 2	Long Dist.
Print Format		Button 3	80-Character
Baud Rate		Button 4	4800 Baud
Forced Account Codes		Button 5	No
Admin Password	Flash 21		2366
Dial Pulse Ratio	Flash 22		
Break/Make		Button 1	60/40
Dial Speed		Button 2	10 pps
LCR Enable	Flash 23		Disabled
DISA Access Code	Flash 24		100
Phone Box Timer	Flash 25		20
Dedicated Attendant Intercom Path	Flash 26		Yes
Background Music	Flash 27		Yes
Setting Time and Date	Flash 28		None
Hook Flash Time	Flash 29		10 (1 sec.)
Hook Switch Bounce Timer	Flash 30		010 msec.
Page Warning Tone	Flash 31		Yes
Attendant Recall Timer	Flash 32		01 min.

Table 600-1 Default Values (Cont'd)

FEATURE	PROGRAM CODE	FLEX BUTTON	DEFAULT VALUE
UCD Timers	Flash 33		
Ring Timer		Button 1	60 sec.
MSG Int.		Button 2	60 sec.
Over Flow Timer		Button 3	60 sec.
Wrap-Up Timer		Button 4	04 sec.
Announcement Table	Flash 34		None
Call Forward No Answer Timer	Flash 35		15s
Voice Mail Groups	Flash 36	Buttons 1-8	None
Voice Mail Outpulsing Tables	Flash 37	Tables 0-7	None
Voice Mail Disconnect Table		Table 8	None
Hunt Groups	Flash 38	Buttons 1-8	None
Weekly Night Mode Schedule	Flash 39		
Manual or Automatic		Button 1	Manual
Schedule Programming		Button 2	0-4 08:00-17:00 5-6 #####-####
SLT Receiver Timer	Flash 41		020
Voice Mail In-Band Digits	Flash 42		Disabled
CO Line Programming	Flash 40		
DTMF/Pulse		Button 1	DTMF
CO/PBX		Button 2	CO
UNA		Button 3	Yes
Loop Supervision		Button 4	No
DISA		Button 5	No
Flash Timer		Button 6	10
CO Line Group		Button 7	1
Line COS		Button 8	1
UCD Ringing Assignment		Button 9	None
CO Ringing Assignment		Button 9 (1)	Ring at Sta 100
Conference Enable/Disable		Button 13	Disabled
Automatic Privacy		Button 14	Enabled
Station Programming	Flash 50		
Paging Access	Page A	Button 1	Yes
DND Access		Button 2	Yes
System Speed Access		Button 3	Yes
Queueing Access		Button 4	Yes
Preferred Line Answer		Button 5	No
Executive Override		Button 6	Disabled
Call Forward Access		Button 7	Yes
Forced LCR		Button 8	No

Table 600-1 Default Values (Cont'd)

FEATURE	PROGRAM CODE	FLEX BUTTON	DEFAULT VALUE
Station Programming (Cont'd)	Flash 50		
LCR COS		Button 9	None
Conference Enable/Disable		Button 13	Disabled
Station Programming	Flash 50		
Station Type	Page B	Button 1	0 (Keyset)
			1 (SLT w/o Msg Wt)
Station Class of Service		Button 2	1
Speakerphone Operation		Button 3	0
Group Pickup Assignment		Button 4	1
Paging Zone Assignment		Button 5	1
Preset Forward Assignment		Button 6	None
CO Line Group Access		Button 7	1
CO Line Button Assignment		Button 8	
Automatic Privacy		Button 13	Enabled
Exception Tables	Flash 60		
Allow Table A		Button 1	None
Deny Table A		Button 2	None
Allow Table B		Button 3	None
Deny Table B		Button 4	None
Special Table 1		Button 5	All Codes Allowed
Special Table 2		Button 6	All Codes Allowed
Special Table 3		Button 7	All Codes Allowed
Special Table 4		Button 8	All Codes Allowed
Least Cost Routing	Flash 61		
3-Digit Routing Table		Button 1	Default
6-Digit Routing Table		Button 2	None
Exception Code Table		Button 3	
Route List Table		Button 4	
Insert/Delete Table		Button 5	
Daily Start Time Table		Button 6	
Weekly Schedule Table		Button 7	
LCR Toll Information		Button 8	LCR Default
			(Figure 660-6)

600.3 PROGRAM MODE ENTRY (Key Station)

Programming is performed at station 100 using either the Enhanced or Executive Key Telephone. Programming is always done at this station regardless of the class of service or which station has been assigned the attendant(s).

Before entering the program mode, the programmer must first verify that the Key Telephone is properly connected to station 100. To enter the program mode:

- A. Press ON/OFF button (LED lights and intercom dial tone is heard).
- B. On the dial pad, press the asterisk [*] twice.
- C. On the dial pad, enter the digits [2][3][6][6] (ADMN). Confirmation tone is heard and dial tone is removed.
- D. The ON/OFF button LED is lit. The System is ready to program. (Other telephones connected to the system continue to function normally.)

NOTE: Initialize here if necessary. (Refer to Section 600.4 and 700.)

- E. Press the FLASH button.
- F. Dial the two-digit program code for the desired data field.
- G. Enter customer data.
- H. To permanently store the entered data, press the HOLD button. A burst of one second confirmation tone should be heard. If an interrupted (error) tone is heard, re-enter the data starting with step e.
- I. Repeat from step e. until all data has been entered into memory.

600.4 INITIALIZATION

The system has been pre-programmed with certain features which are called default data (Refer to Table 600-1). These features are loaded into memory when the system is initialized.

NOTE: The system should be initialized when installed or at any time the data base has been corrupted. (Refer to Section 700 for complete system initialization procedures)

To return the entire system database to default values:

Set switches 1 and 8 on the CPB to ON to initialize upon system power-up. After initialization, switch 8 should be turned to the "OFF" position. (Refer to Section 700 for complete initialization instructions)

Use the procedures explained below to return only parts of the data base to default values:

- A. Enter the programming mode.
- B. Press FLASH button.
- C. Dial [70] to default system parameters.
- D. Press HOLD button.
- E. Repeat from step B for the other areas. In step C, use the following program codes:
 - [70] for system parameters (including all group programming)
 - [71] for CO lines
 - [72] for station parameters
 - [73] for exception tables
 - [74] for system speed numbers
 - [75] for Least Cost Routing Tables

NOTE: Program Codes 70-75 **DOES NOT** initialize the database, but returns all programmable data to its default value.

600.5 CUSTOMER DATA WORKSHEETS

Before any attempt at programming is made, it is strongly recommended that customer data worksheets be prepared (Refer to Appendix A). These worksheets should become part of the permanent record of customer programming. Refer to the following sections when preparing the worksheets.

600.6 DATA BASE FIELDS

The data fields are used to set system timers, determine central office line features and Key Telephone features. When entering CO line data and station data, be sure to enter the exact number of digits specified. The data fields and features are further described in the following sections.

SECTION 610

SYSTEM PARAMETERS PROGRAMMING

610.1 SYSTEM HOLD RECALL TIMER

Programming Steps

If this timer is to be changed:

- A. Press FLASH and dial [01]. The following message is shown on the display phone:

<div style="display: flex; justify-content: space-between;"> SYS HOLD RECALL 000-300 </div> <div style="text-align: center; margin-top: 5px;">060</div>

- B. Enter three digits on the dial pad.
 C. Press HOLD button. Display will now update.

Description

Determines the amount of time before a call placed on System Hold will recall the station placing the hold. If unanswered by that station, the call will recall the attendant.

Default: Default value is 060 seconds and is variable from 001 to 300 seconds.

An entry of 000 will disable the timer and there will be no recall.

Related Programming: Hold Preference programming for selecting System Hold Preference; Attendant Programming for assigning the Attendant(s) to receive recalls.

610.2 EXCLUSIVE HOLD RECALL TIMER

Programming Steps

If this timer is to be changed:

- A. Press FLASH and dial [02]. The following message is shown on the display phone:

<div style="display: flex; justify-content: space-between;"> EXC HOLD RECALL 000-300 </div> <div style="text-align: center; margin-top: 5px;">180</div>

- B. Enter three digits on the dial pad.
 C. Press HOLD button. Display will now update.

Description

Determines amount of time before a call placed on Exclusive Hold recalls the station placing the Hold. If unanswered by that station, the call recalls the attendant.

Default: The default value is 180 seconds and is variable from 001 to 300 seconds.

An entry of 000 will disable the timer and there will be no recall.

Related Programming: Hold Preference programming for selecting Exclusive Hold Preference; Attendant Programming for assigning the Attendant(s) to receive recalls.

610.3 TRANSFER RECALL TIMER

Programming Steps

If this timer is to be changed:

- A. Press FLASH and dial [03]. The following message is shown on the display phone:

TRANSFER RECALL	000-300
045	

- B. Enter three digits on the dial pad.
C. Press HOLD button. Display will now update.

Description

Determines amount of time a transferred call rings at the station receiving the transfer before it recalls the station making the transfer. If unanswered by that station, the call recalls the attendant.

Default: Default value is 045 seconds and is variable from 001 to 300 seconds.

A 000 entry disables the timer and there will be no recall.

Related Programming: Attendant Programming for assigning the Attendant(s) to receive recalls.

610.4 PRESET FORWARD TIMER

Programming Steps

If this timer is to be changed:

- A. Press FLASH and dial [04]. The following message is shown on the display phone:

PRESET FWD TIMER	00-99
10	

- B. Enter two digits on the dial pad.
C. Press HOLD button. Display will now update.

Description

Determines the amount of time an outside line will ring before being forwarded to a predetermined station. This entry works with Preset Forward station assignments in Station Programming. More than one station can be forwarded to the same party.

This timer also governs the time the DISA call will ring at a station before being returned to intercom dial tone, if not answered.

Default: Default time is set at 10 seconds and is variable from 01 to 99 seconds.

A 00 entry disables the timer and there will be no forward.

Related Programming: Preset Forward assignments in Station Programming (Flash 50) for instruction on assigning a stations preset forward destination.

610.5 PAUSE TIMER

Programming Steps

If this timer is to be changed:

- A. Press FLASH and dial [05]. The following message is shown on the display phone:

A rectangular display screen with a halftone background. The text on the screen is arranged as follows: 'PAUSE TIMER' on the left, '2' in the center, and '1-9' on the right.

- B. Enter one digit on the dial pad.
C. Press HOLD button. Display will now update.

Description

Determines the length of the pause when programmed for use with speed dialing and LCR Insert Tables.

Default: Default is 2 seconds and is variable from 1 to 9 seconds. There is no 0 entry.

610.6 CALL PARK RECALL TIMER

Programming Steps

If this timer is to be changed:

- A. Press FLASH and dial [06]. The following message is shown on the display phone:

A rectangular display screen with a halftone background. The text on the screen is arranged as follows: 'CALL PARK TIMER' on the left, '180' in the center, and '000-600' on the right.

- B. Enter three digits on the dial pad.
C. Press HOLD button. Display will now update.

Description

Determines the amount of time before a call placed in the call park location will recall the station placing the call park. If unanswered by that station, the call will recall the attendant.

Default: Default is 180 seconds and is variable from 001 to 600 seconds.

A 000 entry disables the timer and there will be no recall.

Related Programming: Attendant Programming for assigning the Attendant(s) to receive recall ringing.

610.7 CONFERENCE TIMER

Programming Steps

If this timer is to be changed:

- A. Press FLASH and dial [07]. The following message is shown on the display phone:

CONFERENCE TIMER	00-99
10	

- B. Enter two digits on the dial pad.
C. Press HOLD button. Display will now update.

Description

Determines the amount of time an unsupervised conference can continue after the initiator of the conference has exited the conference.

Default: Default is 10 minutes and is variable from 01 to 99 minutes.

A 00 entry disables the timer and means an automatic disconnect occurs.

NOTE: The Conference Timer also allows the system administrator to control the length of time a DISA caller is allowed after establishing a "Trunk-to-Trunk" call. At the expiration of the Conference Timer, a tone will be presented to both DISA parties, then one minute later the system will automatically release both trunks. The Conference Timer does not affect or control a DISA-to-Station call.

Related Programming: Refer to Loop Supervision, DISA and Conference Attributes in CO Line programming. Also refer to the Conference option in Station programming.

610.8 MESSAGE WAIT REMINDER TONE

Programming Steps

If this feature is to be changed:

- A. Press FLASH and dial [08]. The following message is shown on the display phone:

M/W TONE TIMER	000-104
000	

- B. Enter three digits on the dial pad.
C. Press HOLD button. Display will now update.

Description

The Message Wait Tone Timer determines the amount of time between repeated reminder tones to a key telephone with a message waiting.

Key station users may be reminded of a message waiting on their telephone with an audible signal presented at a timed interval.

Default: Default is 000 (disabled) and is variable from 000 to 104 minutes.

610.9 PAGING TIMEOUT TIMERProgramming Steps

If this timer is to be changed:

- A. Press FLASH and dial [09]. The following message is shown on the display phone:

PAGING TIME-OUT	00-60
15	

- B. Enter two digits on the dial pad.
C. Press HOLD button. Display will now update.

Description

Determines the maximum length of a page announcement (internal, external or All Call). The system will automatically disconnect the page at the end of this time unless the person making the page has already hung up.

Default: Default is 15 seconds and is variable from 01 to 60 seconds.

A 00 entry disables the timer and pages will not be limited in length.

Related Programming: Station Attributes for allowing stations access to the system paging resources.

610.10 CO RING DETECT TIMERProgramming Steps

If this timer is to be changed:

- A. Press FLASH and dial [10]. The following message is shown on the display phone:

CO RING DETECT	2-9
3	

- B. Enter one digit on the dial pad.
C. Press HOLD button. Display will now update.

Description

This timer controls the time necessary to detect an outside line as ringing into the system.

Default: Default is 3 (hundred milliseconds) and is variable from: 2 to 9. There is no 0 or 1 entry.

610.11 HOLD PREFERENCE

Programming Steps

If this feature is to be changed:

- A. Press FLASH and dial [11]. The following message is shown on the display phone:

HOLD PREFERENCE	SYS-EXC
SYSTEM	

- B. To make a change, press the top left button in the flexible button field. It will toggle on and off with each depression.
- LED off = Exclusive Hold
 - LED on = System Hold
- C. Press HOLD button.

Description

The system may be programmed to have either Exclusive or System Hold preferred. If Exclusive Hold is preferred, the user will press the HOLD button once for Exclusive Hold and twice for System Hold. If System Hold is preferred, the user will press the HOLD button once for System Hold and twice for Exclusive Hold.

Refer to System Timer programming for recall times for both System and Exclusive Hold.

Default: Default is System Hold.

Related Programming: System Hold Recall Timer and Exclusive Hold Recall Timer for setting the appropriate recall timers.

610.12 EXEC OVERRIDE WARNING TONE

Programming Steps

If this feature is to be changed:

- A. Press FLASH and dial [12]. The following message will then be shown on the display:

EXEC WARNING TONE	YES-NO
YES	

- B. To make a change, press the top left button in the flexible button field. It will toggle on and off with each depression.
- LED off = Executive Override Tone disabled
 - LED on = Executive Override Tone enabled
- C. Press HOLD button. Display will now update.

Description

A Station programmable option allows stations to be designated as "Executive" stations with the ability to override and "barge-in" on other keysets engaged in conversation on a CO line. Prior to actual cut through of the third party, a warning tone is presented to all parties notifying them of the "barge-in".

This warning tone however is a programmable option, on a system wide basis, that either enables or disables the tone. When the tone is disabled no audible signal is presented to the parties to signal the "barge-in".

Related Programming: Station Attributes for assigning stations as Executive stations.

NOTE: A decrease in volume may occur after the "barge-in" occurs if the station is engaged in a CO line conversation.

<p>CAUTION: USE OF THIS FEATURE WHEN THE EXECUTIVE OVERRIDE WARNING TONE IS DISABLED MAY BE INTERPRETED AS A VIOLATION OF FEDERAL OR STATE LAWS, AND AN INVASION OF PRIVACY. CONSULT COUNSEL WITH RESPECT TO APPLICABLE LAW BEFORE INTRUDING ON CALLS USING THIS FEATURE.</p>
--

610.13 EXTERNAL NIGHT RINGProgramming Steps

If this feature is to be changed:

- A. Press FLASH and dial [13]. The following message is shown on the display phone:

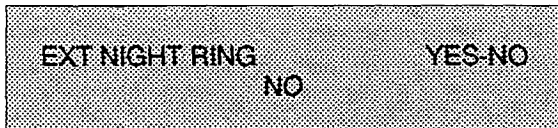

- B. To make a change, press the top left button in the flexible button field. It will toggle on and off with each depression.
- LED off = no
 - LED on = yes
- C. Press HOLD button.

Description

When this feature is set to yes, it activates external night ring through the loud bell 1 contacts. When outside lines are marked UNA, ringing will activate LBC 1 when an incoming call occurs on those lines during night service.

Default: By default this feature is set at no.

Related Programming: Loud Bell Assignments; CO Line Attributes for assigning UNA status to a CO Line(s).

610.14 ATTENDANT OVERRIDEProgramming Steps

If this feature is to be changed:

- A. Press FLASH and dial [14]. The following message is shown on the display phone:

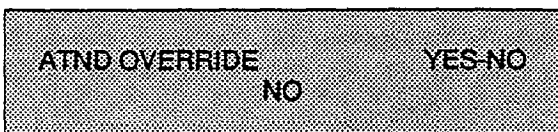

- B. To make a change, press the top left button in the flexible button field. It will toggle on and off with each depression.
- LED off = no
 - LED on = yes
- C. Press HOLD button.

Description

When this feature is set for yes, it allows the attendant with DSS Map 1 to override a busy station or a station in DND.

Default: By default this feature is set at no.

Related Programming: Attendant Assignments for designating a station as an Attendant; Station Attributes for the ID of a DSS unit as Map 1 (ID 1)

NOTE: Attendant override will function **ONLY** when a station assigned as an Attendant has a DSS programmed as Map 1, or a flex button assigned as Attendant Override.

610.15 ATTENDANT STATION

Programming Steps

If Attendant Stations are to be changed:

- A. Press FLASH and dial [15]. The following message is shown on the display phone:

```

ATND STA ASSIGNMENT
100, ### ###
  
```

- B. Enter up to three(3) three-digit station number(s) on the dial pad.
C. Press HOLD button.

Description

The system will identify an attendant station for the purpose of receiving recalls and activating night service. The system can have up to three attendant(s) programmed.

Default: By default station 100 is assigned as attendant. Entering three pounds [###] will remove that attendant assignment or different station numbers can be programmed.

Related Programming: System Hold Recall Timer; Exclusive Hold Recall Timer; Call Park Recall Timer; Attendant Recall Timer; Attendant Override; Night Mode Operation.

610.16 LOUD BELL CONTROL

Programming Steps

If this feature is to be assigned:

- A. Press FLASH and dial [16]. The following message is shown on the display phone:

```

LOUD BELL CONTROL ASSIGN
####, ###
  
```

- B. Enter a 0 or a 1 to indicate if a station or a CO line is being assigned the contacts.
0 = station (S)
1 = CO line (A)
- C. Enter three digit station numbers or two digit CO line numbers.
- D. To program another station or CO line, repeat from step b.
- E. Press HOLD button.

Description

Two contacts are available to be assigned either as Loud Bell Control or as CO Line Control.

A Loud Bell Control contact can be assigned to any station and will follow the ringing assignments of that station including tone ringing intercom, and transferred CO lines.

Remember to assign ringing to any station programmed for LBC.

A CO Line Control contact can be assigned to any CO line. When assigned as CO Line Control, the contact will be "closed" for the duration of the CO Line connection.

Contact #1, when programmed as a Loud Bell Control, will also provide External Night Ringing for CO lines marked to have UNA during the night mode.

Entering [###] will remove an assignment.

Default: By default no stations or CO lines are assigned.

Related Programming: External Night Ringing for assigning LBC #1 as the Night Ringing Control device. Also refer to CO Line Programming for UNA assignment.

610.17 PBX DIALING CODES

Programming Steps

If PBX Dialing Codes are to be assigned:

- A. Press FLASH and dial [17]. The following message is shown on the display phone:

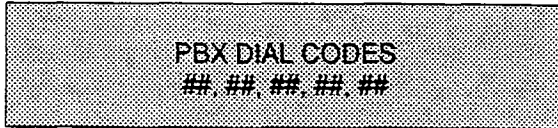

- B. Enter two digit code numbers, one right after the other, on the dial pad up to a maximum of ten digits.
- C. Press HOLD button.

Description

Five one or two-digit PBX access codes can be programmed into memory. When dialed, these codes signal the system so that toll restriction is applied at the next dialed digit. When a single digit code [9] is entered, it must be followed by the pound [#] as the second digit.

To delete an entry, enter two pounds [##] and press the HOLD button.

Lines must be programmed as PBX lines before these codes will apply.

Default: By default no codes are assigned.

Related Programming: CO Line Attributes for assigning a CO Line(s) as PBX Line(s).

610.18 EXECUTIVE/SECRETARY PAIRS

Programming Steps

If Executive/Secretary pairs are to be assigned:

- A. Press FLASH and dial [18]. The following message is shown on the display phone:

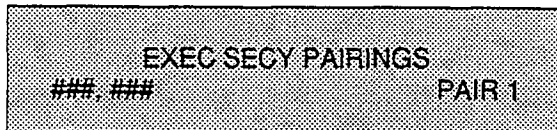

- B. The top left button in the flexible button field will be lit indicating the first pair may be programmed.



- C. Enter the three digit Executive station number.
- D. Enter the three digit Secretary station number.
- E. Press HOLD button.
- F. To program a second pair, press the second button in the flexible button field and enter station numbers as in steps c., d., and e.
- G. To program a third pair, press the third button in the flexible button field and enter station numbers as in steps c., d., and e.
- H. To program a fourth pair, press the fourth button in the flexible button field and enter station numbers as in steps c., d., and e.

Description

There are four Executive/Secretary pairs available. When an Executive station is busy or in DND, intercom calls and transfers will be automatically routed to the designated Secretary.

The assigned secretary may, however, Camp-On to the Executive Station when the station is busy or in Do-Not-Disturb.

There can be only one pairing of stations, with no duplicates. You cannot pair Executive 100 to Secretary 101 and then pair Secretary 101 to Executive 100. You can have the same Secretary station for more than one Executive station (101 to 105 and 102 to 105).

An entry of six pounds [#####] will remove the assignments. Individual pairs may be changed by pressing the associated flexible button.

610.19 UNIFORM CALL DISTRIBUTION (UCD)

A. UCD Group Programming

Programming Steps

If UCD Groups are to be assigned:

1. Press FLASH and dial [19]. The following message is shown on the display phone:

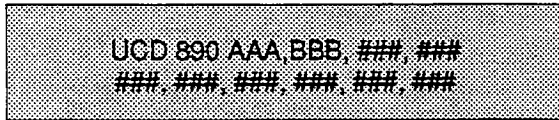

Where:

- AAA= Alternate UCD Group Assignment
- BBB= UCD Overflow Assignment
- ###= UCD Station(s) Assignment(s)

2. The top left button in the flexible button field will be lit for programming UCD group 890. To change UCD groups or enter further UCD groups (891 to 897), press the appropriate flexible button and perform the following procedures.

Description

There can be eight UCD groups of no more than eight stations each. The UCD groups use a pilot hunting technique. If the pilot number is dialed, the assigned stations in that UCD group are searched for the station which has been in an idle condition for the longest period of time.

Each UCD Group may have an assigned Alternate UCD Group, an Overflow station and up to eight stations as UCD members. The two system RAN ports (tables) may also be referenced on a per UCD group basis.

While programming UCD Groups, the flexible buttons are mapped as follows:

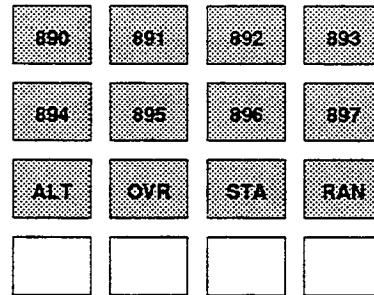

Default: By default, UCD Group Tables are empty.

Related Programming: UCD Timers for setting ringing, Message Interval Timer, Overflow, and Wrap-up Timers, Sec. 610.33; RAN Table programming for assigning RAN device ports and message times, Sec. 610.34.

B. Alternate UCD Group Assignment

Programming Steps

To program an alternate group:

1. Press the ALT flexible button (Button #9).
2. Enter the three-digit pilot number (890 to 897) of the desired alternate UCD group.
3. Press the HOLD button to enter data.

Description

ALT. An alternate UCD group can be programmed so that if no station in one group is available, the alternate group will be checked for an available station. This provides a means to chain or link UCD groups together.

To delete an Alternate UCD Group, press the pound key three times [###] and press the HOLD button.

UNIFORM CALL DISTRIBUTION (Cont'd)**C. Overflow Station Assignment**

<u>Programming Steps</u>	<u>Description</u>
<p>To program UCD Overflow station:</p> <ol style="list-style-type: none"> 1. Press the OVR flexible button (Button #10). 2. Enter the three-digit station number (100 to 195) to designate the UCD Groups overflow station. 3. Press the HOLD button to enter the data. 	<p>OVR. When an overflow station is assigned, callers that have remained in queue for a specified amount of time will be routed to the assigned overflow station. The overflow station may not be one of the UCD group stations. Only CO calls transferred to a UCD group will overflow to the overflow station when RAN tables have not been assigned.</p> <p>To delete an Overflow Station, press the pound key three times [###] and press the HOLD button.</p>

D. UCD Station Assignment(s)

<u>Programming Steps</u>	<u>Description</u>
<p>To program stations into a UCD group:</p> <ol style="list-style-type: none"> 1. Press the STA flexible button (Button #11). 2. Enter the three digit station numbers of the stations in the UCD group in the order in which they will be checked. A maximum of eight stations may be entered. 3. Press HOLD button. 	<p>STA. Any type of station (excluding DSS's and phone boxes) may be entered as valid UCD stations. Calls will be routed to station in the order they are entered for the first round of calls only. After that the calls are routed to stations based on On-Hook time. The station with the longest On-Hook time will receive the next call.</p> <p>If a specific station number is dialed, only that station is rung; no distribution will be done if that station is busy.</p> <p>To erase all stations, press the pound key three times [###] and press HOLD.</p>

E. Recorded Announcement Assignment(s)

<u>Programming Steps</u>	<u>Description</u>
<p>To program a Recorded Announcement:</p> <ol style="list-style-type: none"> 1. Press the RAN flexible button (Button #12). 2. Enter one of the following digit sequences: <ul style="list-style-type: none"> 1 = RAN port specified in Table 1 will be used. 2 = RAN port specified in Table 2 will be used. 1,2 = Port 1 will answer the call; port 2 will provide a subsequent message. 2,1 = Port 2 will answer the call; port 1 will provide a subsequent message. 	<p>RAN. An optional Recorded Announcement device may be connected to the system to provide an announcement if all stations in a UCD group are busy. Two ports in the system may be assigned to provide a path to a Recorded Announcement device. Incoming CO Callers will only be answered and routed to the Overflow assignment if a RAN Table is assigned.</p> <p>To erase Recorded Announcement(s), press the pound key three times [###] and press HOLD.</p> <p>Refer to RAN Announcement Table programming (Sec. 610.34) for further information regarding each RAN Table.</p>

**610.20 STATION MESSAGE DETAIL RE-
CORDING (SMDR)**

A. SMDR Programming

Programming Steps

If Station Message Detail Recording is to be used:

1. Press FLASH and dial [20]. The following message is shown on the display phone:

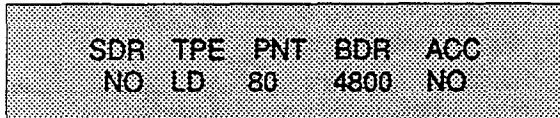

2. To program SMDR features, use the flexible button(s) as defined in the following procedures.
3. The SMDR, TYPE, PRINT, and ACC buttons toggle on and off.
4. After all entries are made, press the HOLD button to accept the data.

Description

The Starplus 96EX Key Telephone System can provide SMDR output to either the standard RS232C connector on the CPB or to the optional RS232C connector allowed for on the APL Board. When SMDR is desired, the following system-wide parameters will determine how the SMDR information will be reported.

When programming SMDR features, the flexible buttons are mapped as follows:

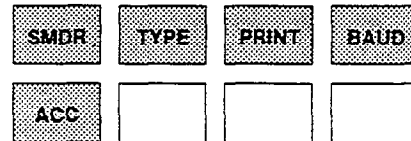

Related Programming: PBX Dialing Codes that may affect SMDR, (Sec. 610.17). SLT Receiver Timer (Sec. 610.40), Station Class of Service, (Sec. 630) and Toll Tables (Sec. 640). Also refer to Section 800 for CPB switch settings to determine which RS232C port SMDR information will appear.

B. SMDR Enable/Disable

Programming Steps

1. Press the SMDR flexible button (Button #1) to enable/disable this feature.
 - LED ON = SMDR is enabled
 - LED OFF = SMDR is disabled
2. Press HOLD button to accept the data.

Description

A call accounting device can be installed allowing the system to track calls by outside line number, number dialed, time of day, date, station that placed or received the call, and duration of the call.

Refer to Sec. 610.40 for further instruction regarding the relationship between SLT Receivers and SMDR.

Default: By default, SMDR is not enabled.

C. Long Distance/Local Assignment

Programming Steps

1. Press the TYPE flexible button (Button #2) to determine the type of calls to be recorded.
 - LED ON = Long Distance is enabled
 - LED OFF = All Calls is enabled
2. Press HOLD button to accept the data.

Description

The system can be set to record either all outgoing calls or only outgoing long distance calls. Long Distance calls are defined as either beginning with a '1' or '0' or containing 8 or more digits. Incoming calls are only recorded if TYPE is set for all calls.

Default: By default, the system is set to record long distance (LD) calls only.

**STATION MESSAGE DETAIL RECORDING
(Cont'd)****D. Character Print Assignment**Programming Steps

1. Press PRINT flexible button (Button #3) to determine the print format of SMDR records.
 - LED ON = 80 Character is enabled
 - LED OFF = 29 Character is enabled
2. Press HOLD button to accept the data.

Description

The system can be programmed to print individual SMDR records in either a 1-line 80 character format or a 3-line 29 character format.

Default: By default, the 1-line 80 character format is selected.

E. Baud Rate AssignmentProgramming Steps

1. Press the BAUD flexible button (Button #4) to determine the baud rate for SMDR records and data base printouts.
2. Enter a one-digit number for the baud rate.
 - 1 = 300 baud
 - 2 = 1200 baud
 - 3 = 4800 baud
3. Press HOLD button to accept the data.

Description

The baud rate for the RS232C port located on the CPB can be set for 300 baud, 1200 baud, or 4800 baud.

Default: By default, the baud rate is 4800.

F. Account Codes - ForcedProgramming Steps

1. Press ACC flexible button (Button #5) to determine whether the use of Account Codes will be forced or optional.
 - LED ON = Account Codes are forced
 - LED OFF = Account Codes are optional
2. Press HOLD button to accept the data.

Description

The system can force the use of account codes on all restricted calls. Once an account code has been entered, the station is not subject to Class of Service restrictions. Stations are not forced to enter an account code for calls allowed by station Class of Service assignments. However, account codes are forced when dialing a number that is restricted by Class of Service assignments. By entering an account code the station's class of service is raised to that equal to COS 1.

Default: By default, the system does not force the use of account codes.

610.21 SET ADMIN. PASSWORD

Programming Steps

If this feature is to be assigned:

- A. Press FLASH and dial [21]. The following message is shown on the display phone:

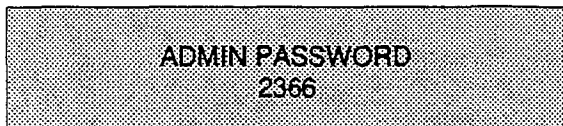

- B. Enter four digits between 0000 and 9999.
- C. Press HOLD button.

Description

The password used to enter customer database programming can be individualized by each customer. This allows the system administrator to block unauthorized personnel from entering database admin.



Care should be taken when changing the programming password so not to "lockout" authorized personnel that may prevent or delay them from making necessary programming changes.

Default: By default the numbers 2366 (ADMN) are assigned.

610.22 DIAL PULSE PARAMETERS

Programming Steps

If this feature is to be assigned:

- A. Press FLASH and dial [22]. The following message is shown on the display phone:

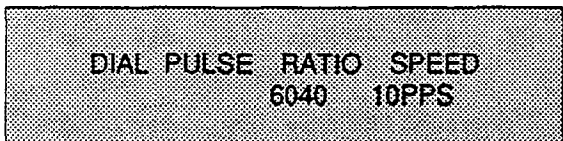

- B. To program dial pulse features, use the flexible button(s) as follows:



- C. The buttons toggle on and off:
 - LED on = 60/40 (RAT), 10pps (SPD)
 - LED off = 66/33 (RAT), 20pps (SPD)
- D. Press HOLD button.

Description

By default all lines are DTMF (tone) signaling. If outpulsing is required, the individual outside line must be programmed for pulse. Refer to CO line programming section. The break/make ratio and the dial speed can be programmed at this time.

Default: By default the break/make ratio (RAT) is set at 60/40 but can be changed to 66/33.

Default: By default the dialing speed (SPD) is 10pps but can be changed to 20pps.

Related Programming: CO Line Attributes (Flash 40); Dial Pulse/DTMF programming.

NOTE: This program code is only used when an outside (CO) line has been programmed for dial pulse.

610.23 LCR ENABLE

Programming Steps

If this feature is to be assigned:

- A. Press FLASH and dial [23]. The following message is shown on the display phone:

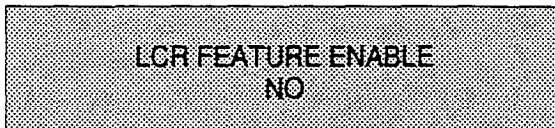

LCR FEATURE ENABLE
NO

- B. The top left button of the flexible button field will toggle on and off:
- LED on = yes
 - LED off = no
- C. Press HOLD button.

Description

If Least Cost Routing is to be used, it must be enabled here. Before enabling LCR, refer to the Least Cost Routing section and programming tables (Appendix A). When the tables have all been programmed, you may then enable LCR for the system. After system initialization, a default LCR data base is loaded into the LCR section of memory. Refer to Figure 670-6 for a listing of the LCR default data-base.

Default: By default, LCR is not enabled (LED off).

Related Programming: LCR Programming.

NOTE: Programming changes to any of the LCR tables can only be performed when LCR is disabled.

610.24 DISA ACCESS CODE

Programming Steps

If this feature is to be assigned:

- A. Press FLASH and dial [24]. The following message is shown on the display phone:

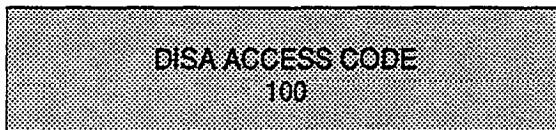

DISA ACCESS CODE
100

- B. Enter three digits on the dial pad.
C. Press HOLD button.

Description

This allows a three digit access code to be assigned to the system. Anyone calling in on a DISA line must use the access code in order to gain access to system features.

Refer to CO line programming for assignment of DISA lines.

To disable the DISA access code, enter three (3) pounds (###).

Default: By default 100 is assigned as the access code.

Related Programming: Preset Forward Timer (Sec. 610.4), Conference Time-out Timer (Sec. 610.8), CO Line Attributes (Sec. 620); DISA programming. A CO Line(s) must be assigned for DISA operation. Also see CO Line Privacy and Conference options.

610.25 PHONE BOX RING TIMER

Programming Steps

If this timer is to be changed:

- A. Press FLASH and dial [25]. The following message is shown on the display phone:

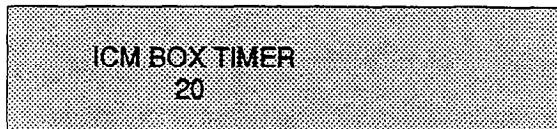

ICM BOX TIMER
20

- B. Enter two digits on the dial pad.
C. Press HOLD button.

Description

Determines the amount of time a station with a DSS button for a particular phone box will ring when the phone box user presses the CALL button.

Default: Default is 20 seconds and is variable from 00 to 60 seconds. A 00 entry will cause programmed stations to ring until the call is answered.

Related Programming: Station attribute for assigning a station as a phone box (ID4). Also refer to Sec. 300 for assigning a flex button as a DSS for the phone box. This is required to receive phone box ringing.

610.26 ATTENDANT DEDICATED INTERCOM

Programming Steps

If this feature is to be assigned:

- A. Press FLASH and dial [26]. The following message is shown on the display phone:

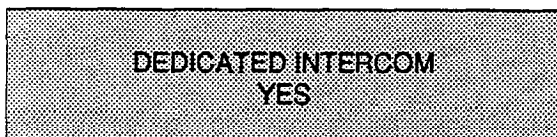

DEDICATED INTERCOM
YES

- B. Press the top left button in the flexible button field. It will toggle on and off with each depression.
- LED on = yes
 - LED off = no
- C. Press HOLD button.

Description

This directs the system to dedicate one intercom path for First (main) programmed Attendant. The 96EX system has 14 intercom paths for use on a shared basis for all stations. (SLT's only have access to 12 paths). If intercom traffic is heavy, dedicating an intercom path to the Attendant will assure proper incoming call processing.

Default: Default enables a dedicated intercom path.

Related Programming: Attendant programming.

610.27 MUSIC CHANNEL

Programming Steps

If Background Music is to be enabled/disabled:

- A. Press FLASH and dial [27]. The following message is shown on the display phone:

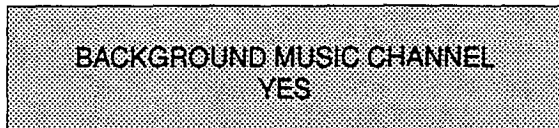

- B. Enter one digit on the dial pad.

- LED on = Background Music
- LED off = No Background Music

Description

The system can be programmed to allow stations to activate Background Music at their stations, in addition to Music-On-Hold. A music source must be connected to the DC/DC Converter.

Default: By default the Background Music channel is enabled.

Related Programming: Phone Box may be programmed for background music. Refer to Station Attributes (Sec. 630): Station ID programming. Use ID [41] to enable BGM at a phone box; ID [40] to disable BGM at a phone box. Also refer to Sec. 300 for Attendant control of BGM at Phone Boxes.

610.28 SETTING SYSTEM TIME AND DATE

Programming Steps

To set the time and date which appears on display Key Telephones:

- A. Press FLASH and dial [28].
 B. Choose display format by pressing the appropriate button in the flexible button field:



- 1 = month/day; 12 hour
- 2 = day/month; 12 hour
- 3 = month/day; 24 hour
- 4 = day/month; 24 hour

- C. Press the HOLD button or dial in the time and date as follows (twelve digits):

YYMMDDHHMMSS

- D. Then press HOLD button.

NOTE: The Time and Date can be changed or set by the First Attendant station

Description

The date can be displayed in either the US (month/day) format or the European (day/month) format on Executive Display stations. In addition, the time can be displayed in either the standard 12 hour format or the 24 hour format.

Default: By default the date is set for month/day format and the time is in the 12 hour format.

When entering the time and date, use the following data:

- YY (year) = 00 to 99
- MM (month) = 01 to 12
- DD (day) = 01 to 31
- HH (hour) = 00 to 23
- MM (minute) = 00 to 59
- SS (second) = 00 to 59 (optional)

Related Programming: Attendant Operation (Sec. 300) for setting System Date and Time from the First Programmed Attendant; Attendant programming for the First Assigned Attendant (Sec. 610.15).

610.29 SLT HOOKSWITCH TIMER

Programming Steps

If this timer is to be changed:

- A. Press FLASH and dial [29]. The following message is shown on the display phone:



- B. Enter a two digit number on the dial pad.
- C. Press HOLD button.

Description

This timer determines how long an SLT user should press the hookswitch in order for it to be considered a valid on hook (disconnect) request. An on-hook shorter in duration (but longer than the Hook Switch Bounce Timer - see below) will be considered a Hook Flash (transfer) request. (Refer to Table 610-1)

The timer is variable from 0.5 seconds to 2.0 seconds. The entry should be a two digit number between 05 and 20.

Default: Default is 10 (one second).

NOTE: Some Single Line telephones have a fixed or programmable Flash Timer (Flash or Tap button). This Hook Switch Timer (96EX Timer) must be set longer than the SLT Flash timer to allow Hook Flash transfer.

610.30 SLT HOOKSWITCH BOUNCE TIMER

Programming Steps

If this timer is to be changed:

- A. Press FLASH and dial [30]. The following message is shown on the display phone:

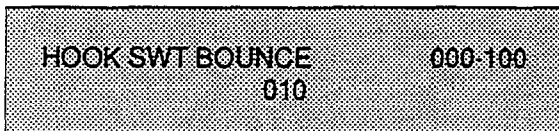

- B. Enter a three digit number on the dial pad.
- C. Press HOLD button.

Description

This timer determines the length of time that is needed to determine a valid on hook or off hook condition for single line telephones. On-Hook or Off-Hook signals that are shorter in duration than this timer will be ignored by the system. (Refer to Table 610.1)

The timer is variable from 0 to 1 second in 10 ms increments This entry is a three-digit entry where 010 equals .1 seconds.

Default: By default, the timer is set to 010 msec.

Table 610-1 Hook Switch Activity

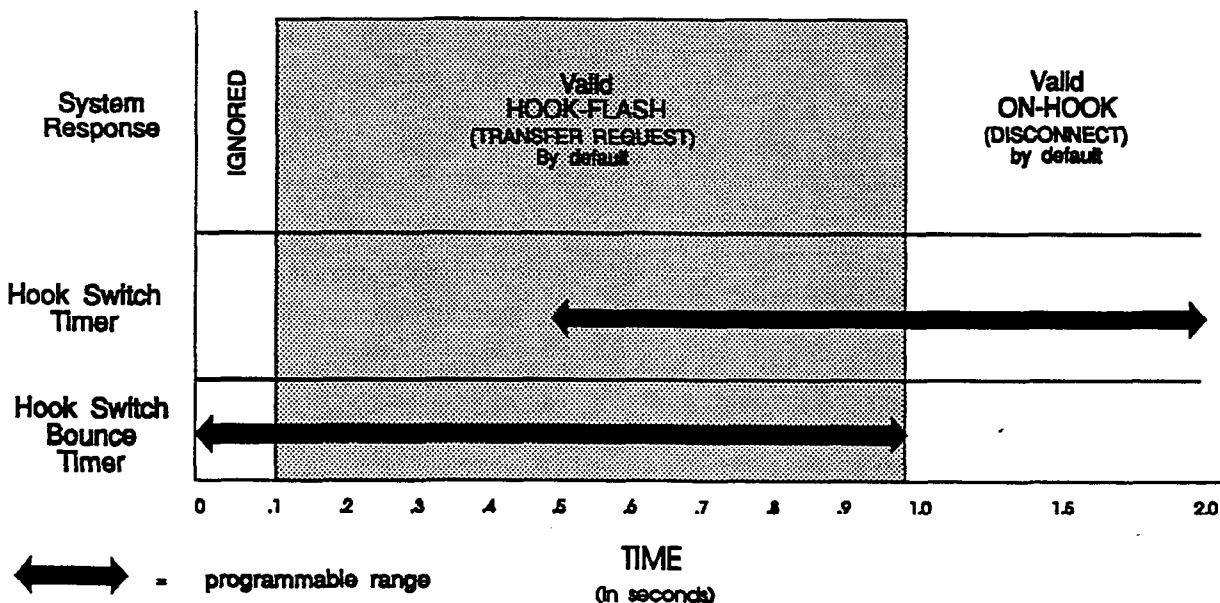

610.31 PAGE WARNING TONE

Programming Steps

If this feature is to be changed:

- A. Press FLASH and dial [31]. The following message is shown on the display phone:

PAGE WARNING TONE	YES-NO
YES	

- B. Toggle the top left button in the flexible button field on or off:

- LED on = yes
- LED off = no

- C. Press HOLD button.

Description

Determines whether a page warning tone will be sounded over the Key Telephone speakers or external paging speakers, prior to the page announcement.

Default: Default is yes.

Related Programming: Station Attributes (Sec. 630), Page Access and Page Group Assignments.

610.32 ATTENDANT RECALL TIMER

Programming Steps

If this timer is to be changed:

- A. Press FLASH and dial [32]. The following message is shown on the display phone:

ATND RECALL TIMER	00-60
01	

- B. Enter two digits on the dial pad.
C. Press HOLD button.

Description

Determines the amount of time a recalling call will ring at the attendant station(s) before the system will release the line.

When a CO Line recalls to the Attendant station and is still unanswered, the system will release the line at the expiration of this timer and automatically place the line back to an idle condition.

Default: This timer is variable from 00 to 60 minutes and default is 01 minutes.

An entry of 00 will cause the Attendant(s) to ring until answered.

Related Programming: Attendant programming; System Hold Recall Timer; Exclusive Hold Recall Timer; Call Park Recall Timer, Transfer Recall Timer. Also refer to Loop Supervision in CO Line programming (Sec. 620).

610.33 UCD TIMERS

Programming Steps

If UCD timers are to be changed:

- A. Press FLASH and dial [33]. The following message is shown on the display phone:

```
UCD TIMERS  RING 060
MIT 060  OVR 060  WRP 004
```

Description

Four timers for UCD operation are programmable on a system-wide basis. The UCD timers include: A Ring Timer, Message Interval Timer, an Overflow Timer, and a Auto Wrap-Up Timer. Each timer is described below:

Related Programming: UCD Group Assignments; Announcement Table programming; Section 500 Installation Section for connection of Music-On-Hold and Recorded Announcements.

When programming UCD Timers, the flexible buttons are mapped as follows:



A. UCD Ring Timer

Programming Steps

To make a change to the UCD Ring Timer:

1. Press the RING flexible button (Button #1).
2. Enter the three-digit timer value on the dial pad which corresponds to 000-300 seconds.
3. Press HOLD button. Display will now update.

Description

The UCD Ring Timer determines how long a call will ring into a busy UCD group before being present to the first recorded announcement.

The timer is variable from 000 to 300 seconds.

Default: Default for this timer is 60 seconds.

NOTE: A RAN Table must be specified in UCD programming (Sec. 610.19) for the ring timer to be in effect. If a RAN Table is NOT specified, incoming CO callers will not be answered but will continue to receive ringback.

B. UCD Message Interval Timer

Programming Steps

To make a change to the UCD Message Interval Timer:

1. Press the MIT flexible button (Button #2).
 2. Enter the three-digit timer value on the dial pad which corresponds to 000-600 seconds.
- Press HOLD button. Display will now update.

NOTE: The UCD Ring and Message Interval Timers only apply when RAN ports have been specified. If RAN ports are not specified, incoming callers will continue to receive ringback tone.

Description

The UCD Message Interval Timer (MIT) determines the length of time a caller remains in queue (listening to MOH, if provided) between recorded announcements.

The timer is variable from 000 to 600 seconds.

Default: Default for this timer is 60 seconds.

UCD TIMERS (Cont'd)

C. UCD Overflow Timer

Programming Steps

To make a change to the UCD Overflow Timer:

1. Press the OVR flexible button (Button #3).
2. Enter the three-digit value on the dial pad which corresponds to 000-600 seconds.
3. Press HOLD button. Display will now update.

Description

The UCD Overflow Timer determines the total length of time a caller will remain in queue for a particular UCD group. When the timer expires, the caller will be routed to the designated overflow station. The timer starts when an incoming call is answered and presented to the first recorded announcement. Transferred CO callers will overflow at the expiration of the Overflow Timer.

The timer is variable from 000 to 600 seconds.

Default: Default for this timer is 60 seconds.

D. UCD Auto Wrap-Up Timer

Programming Steps

To make a change to the UCD Auto Wrap-up Timer:

1. Press the WRAP flexible button (Button #4).
2. Enter the three-digit value on the dial pad which corresponds to 000-999 seconds.
3. Press HOLD button. Display will now update.

Description

After completion of a UCD call (on-hook) the agent will not be subjected to another UCD call for the duration of the Auto Wrap-Up timer allowing the agent to finish call related work or access other facilities. This will allow agents to remove themselves from the group (ie. DND, Call Forward) or originate another call.

Default: This timer is variable from 000-999 seconds. Default is 04 seconds.

610.34 ANNOUNCEMENT TABLES

Programming Steps

If Recorded Announcement devices are installed to operate with UCD, these tables must be programmed:

- A. Press FLASH and dial [34]. The following message is shown on the display phone:

ANNOUNCEMENT TABLE 1
TYPE # INDX ## TIME ###

- B. A string of six, seven, or eight digits is entered on the dial pad. The order of data entry will be:

Table Number:

- 1= Table 1
2= Table 2

Type Number:*

- 0= APL RAN port
1= CO Port interface
2= SLT Port interface

Index (port) Number:

- 0= APL in Basic KSU
01-40= CO Line Port
100-195= SLT Station Port

Message Time:

000-300 seconds

* When the APB RAN port is used along with the message stop leads, set the message duration timer approximately 5 seconds longer than the actual message.

- C. Press HOLD button.

- D. To enter data for Table 2, enter 2 as the first digit in the string.

NOTE: When a CO port is designated as a RAN port, it is recommended that a LBC contact also be installed in the system. The contacts should then be programmed as a CO Line Control for the port specified as a RAN port. One LBC contact is provided with each Power Failure Transfer Unit (PFT)

Description

Determines the type, index (port) number and message length for the two available Recorded Announcements (RAN). There are two RAN tables that can be programmed. Table 1 can be the answer port for unanswered incoming calls to a UCD group. Table 2 can provide the secondary message or vice versa.

The type can be either the RAN port on the APB board, a CO line port, or a SLT port. The index number specifies which circuit for the type of interface.

The message length is used to match the maximum length of the message to the device that is used.

Example:

To program Table 1 for the APB RAN port:

- A. Dial [1] for Table 1.
B. Dial [0] for RAN port on APB.
C. Dial [0] for APB in Basic KSU.
D. Enter message duration (000-300 sec.)

To program Table 1 for CO line port:

- A. Dial [1] for Table 1.
B. Dial [1] for CO port interface.
C. Dial [01 to 40] for CO line used.
D. Enter message duration (000-300 sec.)

To program Table 1 for SLT port:

- A. Dial [1] for Table 1.
B. Dial [2] for SLT port interface.
C. Dial [100 to 195] for SLT station used.
D. Enter Message duration (000-300 sec.)

Related Programming: UCD Group programming; UCD Timer programming; Section 500 Installation Section for instructions on how to install Recorded Announcement devices.

610.36 VOICE MAIL GROUPS

A. Voice Mail Programming

Programming Steps

If Voice Mail Groups are to be programmed:

1. Press FLASH and dial [36]. The following message is shown on the display phone.

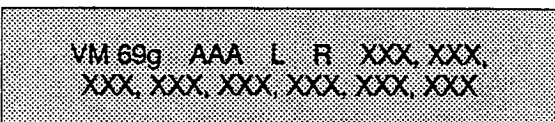

Where:

- g= voice mail group number (0-7)
 - AAA= alternate group (690-697)
 - L= "Leave" mail index from outpulsing table for leaving messages (0-7)
 - R= "Retrieve" mail index from outpulsing table for retrieving messages (0-7)
 - xxx= voice mail station numbers (ports). (up to 8 max.)
2. The top left button in the flexible button field will be lit for programming voice mail group 690. To change Voice Mail groups or enter further Voice Mail groups, press the appropriate flexible button 1-8 (690-697) and perform the following procedures.

NOTE: Certain programming will be required in the Voice Mail system connected to the 96EX for proper operation.

1. Mail Box numbers must match 96EX station extension numbers. (100-195)
2. Tone Mode Calling option (5#) must be programmed as leading digits in transfer sequence(s) to force tone ringing to key telephone.

B. Alternate Voice Mail Group Assignment

Programming Steps

To program an alternate group:

1. Press the AAA flexible button (Button #9).
2. Enter the three-digit pilot number (690 to 697) of the desired group.
3. Press the HOLD button to enter data.

Description

Up to eight (8) Voice Mail groups can be configured in the 96EX system. Each group can contain up to eight (8) Voice Mail designated ports, each of which interfaces with a port on an SLT or OPX card. An APB and Ring Generator is also required.

An externally provided Voice Mail system or Auto Attendant must be connected to the 96EX system for Voice Mail or Auto Attendant operation. Voice Mail automatically handles unanswered calls. Station user can then retrieve messages left at their stations. Auto Attendants can handle incoming calls and route callers to station users without intervention from the systems attendant.

Direct incoming ring to Voice Mail/Auto Attendant groups can be done directly through CO Line Ringing Assignments.

When programming Voice Mail Groups, the flexible buttons are mapped as follows:

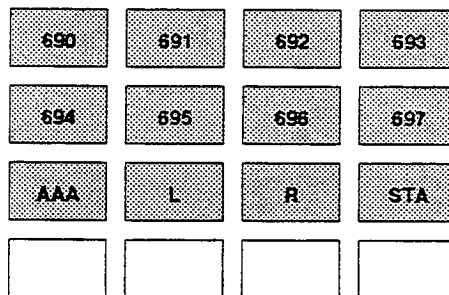

Related Programming: Voice Mail Outpulsing Table (Sec. 610.37), Voice Mail ID digits for incoming CO calls (Sec. 610.41), CO Line Attributes, CO Line Ringing Assignments(Sec. 620).

Description

ALT. An Alternate Voice Mail Group may be programmed so that if all Voice Mail ports are in use, the call can be routed to an alternate group. This is useful when more than eight ports are required for Voice Mail traffic.

To delete an Alternate Voice Mail Group assignment, enter three pounds [###] on the keypad and press the HOLD button.

VOICE MAIL GROUPS (Cont'd)**C. "Leave" Mail Index Entry**Programming Steps

To specify the "Leave" mail index (outpulsing table) to be accessed by a Voice Mail group:

1. Press the L flexible button (Button #10).
2. Enter the one-digit outpulsing table number (0-7) on the dial pad.
3. Press the HOLD button to enter the data.

Description

L. The "Leave" mail index specifies the outpulsing Table where the "in-band" digits required to connect a caller, forwarded into Voice Mail, to the called stations mail box are stored. Refer to Sec. 610.37 for programming entries into an outpulsing table.

To delete a "Leave" mail index entry, enter three pounds [###] on the keypad and press the HOLD button.

D. "Retrieve" Mail Index EntryProgramming Steps

To program the "Retrieve" mail index (outpulsing table) to be accessed by the Voice Mail group:

1. Press the R flexible button (Button #11).
2. Enter the one-digit outpulsing table number (0-7) on the dial pad.
3. Press the HOLD button to enter the data.

Description

R. The "Retrieve" mail Index specifies the outpulsing table where the "In-band" digits required to connect a station user to their own mail box are stored. Refer to Sec. 610.37 for programming entries into an outpulsing table.

NOTE: In order for the Starplus 96EX System to send the Station Identification digits (station three-digit extension number), a "Leave" and a "Retrieve" table must be referenced when assigning Voice Mail groups. However, the "Leave" and "Retrieve" outpulsing Tables (Sec. 610.37) can be empty (no entries in the referenced table).

To delete a "Retrieve" mail index entry, enter three pounds [###] on the keypad and press the HOLD button.

E. Voice Mail Station Assignment(s)Programming Steps

To program the stations in the Voice Mail group:

1. Press the STA flexible button (Button #12).
2. Enter the three digit station numbers. A maximum of eight SLT stations may be entered.
3. Press the HOLD button to enter the data.

Description

Up to eight (8) SLT or OPX port extension numbers may be programmed into a Voice Mail group.

The ports will be designated as two-way ports by directing calls to any one of the ports and allowing any one of the ports (or all ports) to be used as VM outdial and/or VM notify ports.

A flexible button may be programmed with a Voice Mail group pilot number. This button will then act as a DSS for that Voice Mail group when pressed and also serves as the message waiting indication for that VM group.

610.37 VOICE MAIL OUTPUTSING TABLE

A. Voice Mail In-Band Signaling:

Programming Steps

Description

If Voice Mail In-Band signalling is to be used:

1. Press FLASH and dial [37]. The following message is shown on the display phone.

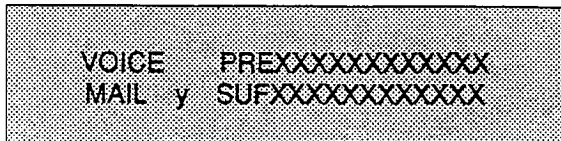

Where:

- y = the table index (0-7)
- x = entered digits (0-9, #, *, Pauses)

2. Dial [0]-[7] for the y value (the table number entry of the voice mail entry you want to program).
3. Dial one of the following, if required:
 - 0 = if a prefix is required
 - 1 = if a suffix is required
 - # = if entry is to be deleted
4. Enter up to 12 digits required including '*' and '#'. TRAN button = pause.
5. Press the HOLD button. Display will now update.

Flex button 12 can be used to display the entries in the voice mail outputsing table. Each depression of the button will advance the user, one entry at a time, through the table.

Entries into one of the eight (8) Voice Mail Outputsing Tables determine the In-Band signaling required for "Retrieving" messages (allows for stations to pick up mail) and "Leaving" messages (allows stations to leave messages in voice mail).

Build a table ("0" for example) for any additional digits other than the Station Extension Number (Voice Mail Box Number) needed for a caller to leave a message in a station's mailbox. ("Leave")

Build another table ("1" for example) for any additional digits needed for a mailbox holder to retrieve a message ("Retrieve").

NOTE: Entries are not required in the Outputsing Table, however a table must be referenced when setting up the Voice Mail groups (FLASH 36) for both Leave and Retrieve data fields, if In-Band signaling is desired.

Related Programming: Voice Mail Group programming, In-band digits sent on incoming CO Calls.

VOICE MAIL OUTPULSING TABLE (Cont'd)

B. Voice Mail Disconnect Table:

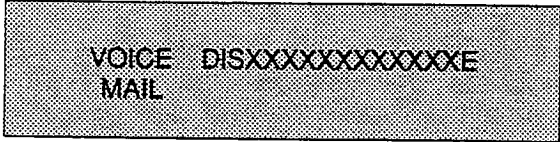
<u>Programming Steps</u>	<u>Description</u>
<ol style="list-style-type: none"> 1. Dial [8] for Table 8 (the table number used for the Voice Mail disconnect signal). 2. Dial [0] for prefix. (required) 3. Enter up to 12 digits which will be used for the disconnect signal, including '*' and '#'. TRAN button = pause. 4. Press the HOLD button. Display will now update. 	<p>To avoid Voice Mail ports from being tied up as a result of CO line callers abandoning the call or not exiting the VM system properly, a disconnect signal can be programmed into the 96EX system to notify the VM system that a call has been abandoned. This is accomplished through "in-band" signaling. If a CO disconnect signal is detected, the 96EX will send a series of DTMF digits programmed in the Voice Mail disconnect table (outpulsing table eight (8)) to the Voice Mail port. This can be any digit stream up to 12 digits including "*" and "#". This table will serve all eight voice mail groups. These digits are not used as a result of an internal station disconnecting from Voice Mail. In this case silence is provided for a short period followed by busy tone. This method is also used for CO lines when the VM disconnect table is empty.</p> <p>The 96EX system will provide Loop Supervision monitoring while a CO call is connected to a port designated as Voice Mail.</p> <p>Default: By default programming there are no entries in the disconnect table (table eight (8)).</p> <p><i>NOTE: Loop supervision must be enabled on the CO lines (in CO line programming) in order for VM disconnect feature to operate.</i></p>
 <p>VOICE DISXXXXXXXXXXXXE MAIL</p>	

610.38 HUNT GROUPS

A. Hunt Group Programming

Programming Steps

If Hunt Groups are to be assigned:

1. Press FLASH and dial [38]. The following message will be shown on the display:

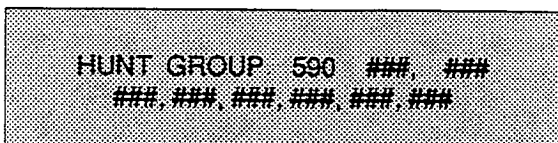

2. The top left button in the flexible button field will be lit for programming Hunt Group 590. To change Hunt Groups or enter a different Hunt Group, press the appropriate flexible button 1-8 (590-597) and perform the following procedures.
3. Enter the 3-digit station numbers up to a maximum of 24 digits (8 stations). Hunts groups are joined together by entering another Hunt Group Pilot Number as the last entry of the group.
4. Press HOLD button. Confirmation tone is heard.

B. Station/Pilot Hunting Assignment

Programming Steps

1. Press the S/P flexible button (Button #9) to indicate Station Hunting or Pilot Hunting.
 - LED on= Station Hunting enabled
 - LED off= Pilot Hunting enabled

Description

The system can be arranged for up to eight hunt groups. Each hunt group can contain up to eight stations each. Each hunt groups can be independently arranged to utilize either a pilot hunting technique or station hunting technique. Hunt groups may also be chained together when larger Hunt groups are desired.

Hunt groups can be joined together by programming another hunt group number as the last member of a hunt group.

If a station is in DND or is forwarded to another station, it is considered busy.

To remove stations from a hunt group, enter three ### (pounds) on the keypad and press HOLD button. This will remove all stations previously programmed in that group.

When programming Hunt Groups, the flexible buttons are mapped as follows:

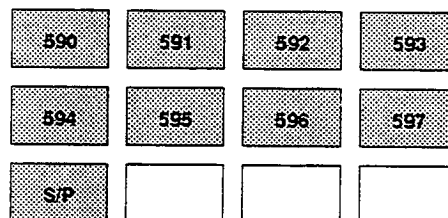

Description

- Pilot Hunting. Incoming CO, transferred CO, and intercom calls can be directed to a pilot number of a hunt group. The system will search sequentially (in the order the extensions were entered in the data base programming) for an idle station in the group and will ring that station. Calls directed directly to stations (by calling the extension number) within the hunt group will not hunt but receive call progress tones from the extension.
- Station Hunting. Incoming CO, transferred CO, and intercom calls that are presented to a busy, or DND station, that is a member of a Station Hunt group, will search sequentially (in the order the extensions were entered in data base programming) for an idle station in the group and will ring that station. Calls will still be allowed to be directed to the groups pilot number for hunting.

610.39 WEEKLY NIGHT MODE SCHEDULE

Programming Steps

If entries or changes need to be made to this schedule:

- A. Press FLASH and dial [39]. The following message will then be shown on the display:

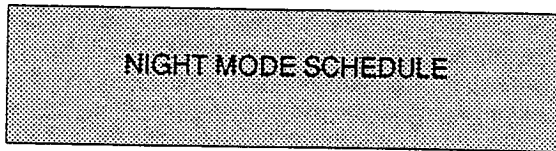

A. Automatic/Manual Operation

Programming Steps

1. Press the AUTO/MAN flexible button (Button #1).
 - LED on= Automatic Night Mode
 - LED off= Manual operation.

B. Day of Week programming

Programming Steps

1. Press the DAY OF WEEK flexible button. (Button #2).
2. Dial a digit (0-6) for the day of the week (see below) followed by four digits to indicate the hour and minutes to end night mode.
3. Then dial four digits to indicate the hour and minutes for the system to go into the night mode for that particular day.

C. Time of Day Display

Programming Steps

1. Button #3 will display the programmed times for each day one at a time.

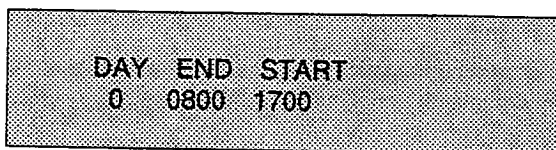

Description

The Starplus 96EX system can be programmed so that the system is automatically placed into and out of night mode. A programmable weekly time schedule allows the system administrator to preset the time the system is put into night mode and the time to remove night mode on a daily basis including weekend operation.

Related Programming: Ringing Assignments; Night Class of Service (COS) assignments; Attendant station assignments.

When programming Night Mode Schedule, the flexible buttons are mapped as follows:



Description

If the system is operated in the automatic night mode the attendant(s) can override the automatic mode by pressing the night key on the attendant(s) phone. The schedule will not go back into effect until the attendant(s) press the night key again.

When the system is placed into night mode CO line ringing will follow the Night ringing assignments and stations will be governed by their respective night COS.

Default: The default times for automatic night mode is as follows:

Monday thru Friday 08:00 17:00
(day time operation 8:00am to 5:00pm)
Saturday and Sunday ##:## ##:##
(24 hour night mode operation)

An entry of "00:00 23:59" would indicate 24 hours of day mode

Each day is displayed in sequential order where:

- 0= Monday
- 1= Tuesday
- 2= Wednesday
- 3= Thursday
- 4= Friday
- 5= Saturday
- 6= Sunday

610.40 SLT DTMF RECEIVER TIMER

Programming Steps

If the SLT DTMF Receiver Timer is to be changed:

1. Press FLASH and dial [41]. The following message will then be shown on the display.

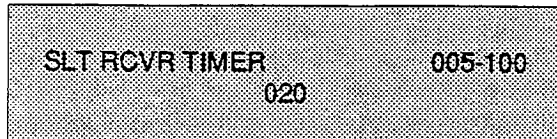

SLT RCVR TIMER 005-100
 020

2. Enter the three digits on the dial pad.
3. Press the HOLD button. The display will now update.

Description

Single line telephones require the use of a DTMF receiver when going off-hook and dialing. When SMDR or toll restriction, (via COS assignments) is enabled in the system a DTMF receiver will monitor and screen an SLT's digits for the duration of this timer. By adjusting this timer the system administrator may either free up system DTMF receivers sooner if system SLT traffic is heavy or provide for a longer monitoring period if toll restriction becomes a problem. It should be understood that when LCR is enabled the DTMF receivers are released when the expected number of digits are dialed as entered in the LCR data base.

Default: By default, the timer is set at 020 seconds.

Related Programming: SMDR programming (sec. 610.20); Toll Restriction in both Co line and Station Attributes programming. Also refer to LCR programming.

610.41 VOICE MAIL IN-BAND DIGITS

Programming Steps

If Voice Mail ID digits are to be enabled or disabled for Incoming CO callers:

1. Press FLASH and dial [42]. The following message will be shown on the display:

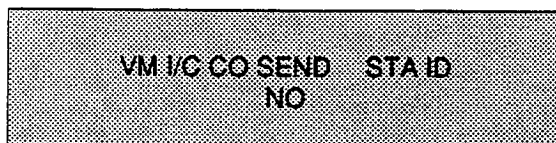

VM I/C CO SEND STA ID
 NO

2. Press Flex button 1 to enable or disable ID digits.
 - LED on = ID digits are enabled
 - LED off = ID digits are disabled
3. Press HOLD button. The display will now update.

Description

The Starplus 96EX allows the system to be programmed so that if a station programmed to receive incoming CO line ringing is forwarded to Voice Mail they may have direct incoming callers routed directly into their stations voice mail box through the use of "In-Band" signalling. Alternately, when disabled, callers will be answered by the Voice Mail or Auto Attendant Main greeting.

Incoming CO callers can be Station Call Forwarded into voice mail only when the ringing CO line is programmed to ring at one station. Additionally CO lines programmed to ring at an attendant station will station call forward into the Voice Mail system (if programmed to ring only at one attendant station) and be presented to the main greeting (not the attendant stations mail box) even when ID digits are enabled.

Default: By default, ID digits for incoming CO calls is disabled.

Related Programming: Voice Mail group programming (sec 610.36); Voice Mail Outpulsing table (sec 610.37)

SECTION 620

CO LINE ATTRIBUTES PROGRAMMING

620.1 CO LINE PROGRAMMING

Programming Steps

If the system is in the programming mode, continue using program codes. If starting to program here, enter the programming mode first (Refer to Paragraph 600.3).

If any CO line features are to be changed:

- A. Press FLASH and dial [40]. The following message is shown on the display phone:

CO LINE ATTRIBUTES
SELECT A CO LINE RANGE

- B. Program button 12 (SLCT) will be lit. Enter a four digit number for the range of lines being programmed. If only one line is being programmed, enter that number twice (0101).
- C. Press HOLD button. The following message is shown on the display phone to indicate current programming of that line or group of lines.

CO ### DT CO UNA
FL10 GRP1 COS1 C P

Where:

##-##= The CO Line Range being programmed.

Description

This section describes the procedures and steps necessary to program CO Line attributes. When entering the CO Line attributes portion of the data base the programmer may decide to enter information for either a range of CO lines or one specific CO Line.

Range programming allows the programmer to change a specific parameter or a few parameters for an entire range of CO Lines leaving intact the remaining data fields that do not require change. Those data fields will continue to operate with the previously programmed data. For example if CO lines are programmed into several CO line groups with different Class of service etc... but it is desired to enable Loop Supervision (SUPV) on all CO Lines the programmer may enter as the range ALL CO lines (01-40) and enable loop supervision, then exit programming. This will enable loop supervision for all CO lines leaving intact the various CO line group programming and COS data for the range.

The buttons on the key telephone are defined as shown below when entering the CO Line Attribute programming.

DTMF	CO	UNA	SUPV
DISA	FLASH	GROUP	COS
RING*	FWD	BACK	SLCT
CONF	PRIV		

Button #10 (FWD) will take you to the next higher CO line. Button #11 (BACK) will take you to the next lower CO line.

CO LINE PROGRAMMING (Cont'd)**A. DTMF/Dial Pulse Programming**Programming Steps

1. Press the DTMF flexible button (Button #1).
 - LED on = DTMF enabled
 - LED off= Dial Pulse enabled
2. Press the HOLD button to enter data.

Description

DTMF. Each individual outside line can be programmed to be either DTMF (tone) or dial pulse. When a line is assigned as dial pulse, you can program the break/ make ratio and dial speed.

Default: By default all are set for DTMF.

Related Programming: Refer to Dial Pulse parameter (Sec. 610.22), and Ring Detect Timer (Sec. 610.10).

B. CO/PBX ProgrammingProgramming Steps

1. Press the CO flexible button (Button #2).
 - LED on = CO type is enabled
 - LED off= PBX is enabled
2. Press the HOLD button to enter data.

Description

CO. Each individual outside line connected to the system may be programmed as either a CO or PBX line. Also use the PBX mark when identifying Centrex lines.

Default: By default, all lines are CO.

Related Programming: Refer to PBX Dialing Codes (Sec. 610.17), Ring Detect Timer (Sec. 610.10), and Flash Timer later in this section.

C. UNA ProgrammingProgramming Steps

1. Press the UNA flexible button (Button #3).
 - LED on = UNA is enabled
 - LED off= UNA is disabled
2. Press the HOLD button to enter data.

Description

UNA. If a line is marked UNA, this activates night service answering of incoming calls on this line by stations not normally assigned access to the line(s). The station must have a direct co appearance or a loop key assigned to do this. Lines marked as UNA will also activate Loud Bell Control Contact #1 when in the night mode if External Night Ringing is set to yes.

Default: Default is yes.

Related Programming: Refer to External Night Ring (Sec. 610.13), and Loud Bell Control (Sec. 610.16).

CO LINE PROGRAMMING (Cont'd)

D. Loop Supervision Programming

Programming Steps

1. Press the SUPV flexible button (Button #4).
2. Enter a one-digit timer value on the dial pad between 1 and 9 which corresponds to 100-900 msec.
3. Press the HOLD button to enter data.

Description

SUPV. Loop supervision is used primarily with DISA, Voice Mail/Auto Attendant and with unsupervised conference applications. It provides the system with the ability to detect when loop current has been broken and an outside line is no longer being used. (To determine timer value for loop supervision, consult your local serving central office for type and duration of loop supervision signal.)

It is recommended that Loop Supervision be enabled, especially when connecting a Voice Mail or Auto Attendant to the 96EX System.

Default: By default, loop supervision is disabled for all CO Lines.

Related Programming: Conference Timer (Sec. 610.7), DISA programming (see below), Voice Mail programming (Sec. 610.36 and 610.37).

E. DISA Programming

Programming Steps

1. Press the DISA flexible button (Button #5).
 - LED on = CO lines set for DISA
 - LED off= DISA is disabled
2. Enter a one-digit value to indicate type of DISA desired.
 - 1= 24 hour
 - 2= Night only
 - 3= no DISA (disable DISA)
3. Press the HOLD button to enter data.

Description

DISA. A line can be assigned as a DISA line during night service only or on a 24 hour basis.

A maximum of three DISA lines can be programmed into the system. A DISA access code can also be programmed. Incoming DISA callers may dial any valid internal station or access outside line groups. DISA callers will be subjected to the Class of Service placed on the line accessed for outdialing. It is recommended that Loop Supervision be enabled when setting up DISA line(s). The Conference Timer (see Sec. 610.7) also allows the system administrator to control the length of time a DISA caller is allowed after establishing a "Trunk-to-Trunk" call. After expiration of the Conference Timer, a tone will be presented to both DISA parties, then one minute later the system will automatically release both trunks. The Conference Timer does not affect or control a DISA-to-Station call.

Default: By default, there are no outside lines assigned as DISA lines.

Related Programming: Conference Timer (Sec. 610.7, DISA Access Code (Sec. 610.24), Loop Supervision (see above), CO Line Conference (see below), CO Line Class of Service (see below), Toll Tables (Sec. 640).

CO LINE PROGRAMMING (Cont'd)**F. Flash Timer Programming**Programming Steps

1. Press the FLASH flexible button (Button #6).
2. Enter a two-digit timer value between 01-20 which corresponds to 100msec-2 seconds.
3. Press the HOLD button to enter data.

Description

FLASH. Flash is a programmable opening on a line for signaling. When using an outside line, flash allows a user to obtain new dial tone without losing the line. This is particularly useful behind a PBX or Centrex. Each individual CO line can be programmed for a flash time.

Default: Default is 10 (1.0 seconds) and is variable from 01 to 20 (100msec. to 2 seconds).

Related Programming: CO/PBX programming.

G. Line Group ProgrammingProgramming Steps

1. Press the GROUP flexible button (Button #7).
2. Enter a one-digit value between 1-8 which corresponds to Groups 1-8.
3. Press the HOLD button to enter data.

Description

GROUP. Eight line groups are available for CO line assignment. Groups should be assigned according to type (local, FX, WATS, etc.) Line group 0 is used for programming a line(s) as a private line.

Line Grouping affects Line Queuing, Pooled Group access (Pool Buttons), Speed Dial, and LCR features.

Default: All lines are placed in line group 1 by default.

Related Programming: Flex Button programming - Pool Buttons (Sec. 630), LCR Programming - Routing Tables (Sec. 650).

CO LINE PROGRAMMING (Cont'd)

H. Class of Service (COS) Programming

- Programming Steps
1. Press the COS flexible button (Button #8).
 2. Enter a one-digit value between 1-5 which corresponds to five possible class of service to which a line may be assigned:
 COS1= No restrictions.
 COS2= Table A governs, Station COS 2 and 4 are monitored.
 COS3= Table B governs, Station COS 3 and 4 are monitored.
 COS4= Restricts 0,1,*,# dialed as first digit and places a seven digit dialing limitation. In addition, 1-800, 1911, and 1611 are allowed and 411, 976, and 555 numbers are denied.
 COS5= Overrides station COS 2,3,4, and 5 and allows unrestricted dialing.
 3. Press the HOLD button to enter data.

Description

COS. Through assignments of a CO Class of Service the assigned CO line will either interact with a station Class of Service, provide a "canned" restriction or provide unrestricted dialing capabilities. (When a CO line is marked PBX, COS restrictions apply to the station only if one of four codes are dialed first.)

Refer to Table 620-1 for CO to Station COS relationship.

Default: By default, all CO lines are assigned Class of Service 1.

Related Programming: Station Class of Service programming (Sec. 630), Toll Table programming (Sec. 640).

Table 620-1 Class of Service (COS)

		CO LINE CLASS OF SERVICE				
		1	2	3	4	5
S T A C O S	1	Unrestricted	Unrestricted	Unrestricted	Canned Restriction*	Unrestricted
	2	Table A	Table A	Unrestricted	Canned Restriction	Unrestricted
	3	Table B	Unrestricted	Table B	Canned Restriction	Unrestricted
	4	Tables A&B	Table A	Table B	Canned Restriction	Unrestricted
	5	Canned Restriction	Canned Restriction	Canned Restriction	Canned Restriction	Unrestricted
	6	Intercom only	Intercom only	Intercom only	Intercom only	Intercom only
Canned Restriction= No '0', 1, #, '' as a first dialed digit, and 7 digits maximum plus 1-800, 1911, 1611 are allowed and 411, 976, and 555 numbers are denied.						

CO LINE PROGRAMMING (Cont'd)

I. CO Line Ringing Assignment

Programming Steps

Each CO line in the system may be assigned initial incoming ringing to one of the following destinations:

- one or more stations (keyset or SLT)
 - to a UCD, Voice Mail or Hunt Group
 - Off-Net (via speed dial)
1. Press the RING ASSIGN flexible button (Button #9) to toggle to the Ringing Assignment display. The display will show the following information:

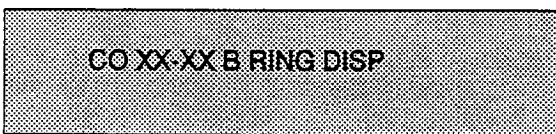

BTN ATTRIBUTE

- 1 CO Ringing Assignments
- 2 Display CO Ringing Assignments

Description

When ringing is assigned as a part of the CO line parameters, ringing of a station is independent of that stations button configuration. However, Stations that are assigned for initial ring-in **MUST HAVE** a LOOP button(s) to answer the call(s) if a direct CO appearance is not available.

Multiple station assignments are allowed for a particular CO line in a mixture of Day, Night, or Day & Night ring types. An incoming CO line may be programmed to any number of stations but it cannot be programmed to ring a mixture of stations and groups (ie. a Hunt Group and 4 stations, or more than one Hunt Group).

Incoming calls directed Off-Net will be connected to an outgoing system speed bin.

CO lines assigned to ring multiple stations will not follow any stations' forward to a UCD, Voice Mail, Hunt Group or Off-Net. Forwarding to another station will be allowed.

To program CO line(s) ringing assignments, use the flexible buttons as follows:

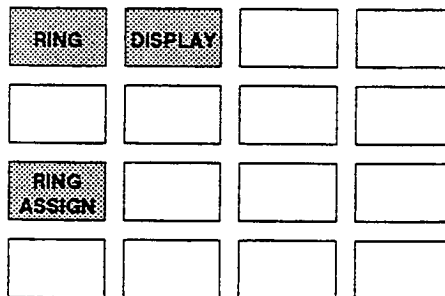

CO LINE PROGRAMMING (Cont'd)

CO Line Ringing Assignments (Cont'd)

Programming Steps

2. Press the RING flexible button (Button #1) to program ring assignments. The following information will be shown:

```

CO RING ASSIGNMENT
ENTER DDDR
  
```

3. Enter the 3-digit destination (DDD) and the single digit ring type (R) followed by the HOLD button.

Valid 3 digit destinations are:

- 020-099 = System Speed Bins 20-99, for off-net ringing.
- 100-195 = Station extension Numbers
- 590-597 = Hunt Groups 1-8
- 690-697 = Voice Mail Groups 1-8
- 890-897 = UCD Groups 1-8

Valid Ring types are:

- 0 = unassigned (to delete a station)
- 1 = Day Ringing
- 2 = Night Ringing
- 3 = Day & Night Ringing

4. Press Button #2 to display ring assignments. Assignments will be displayed in sets of 8 up to the number programmed. Press Button #2 additional times to cycle to the next group of 8 ring assignments.

The following LCD format will be used to display the assignments:

```

DDDR DDDR DDDR DDDR
DDDR DDDR DDDR DDDR
  
```

Where:

DDD= Destination

R= D for Day

N= Night

B= Both Day & Night.

Ring assignments will be continuous and will be displayed in order of the destination number from 001 to 987.

Description

Multiple station assignments are accomplished by assigning another destination with ring status, DDDR, and pressing the HOLD button. This can be done for up to the maximum number of stations on the system.

Deleting a station (entering a 0 for ring type) only removes that station from the ring assignment.

Default: By default all CO lines are assigned to ring at the attendant, Station 100.

CO LINE PROGRAMMING (Cont'd)

J. Conference Enable/Disable (Per CO Line)

Programming Steps

To program Conference Enable/Disable:

1. Press the CONF flexible button (Button #13).
 - LED on = Conference is enabled
 - LED off = Conference is disabled
2. Press HOLD button. Display will now update.

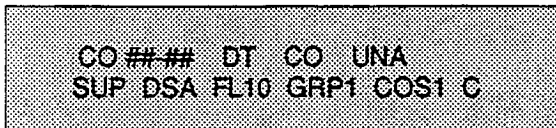

Description

This feature allows each CO line to be programmed to allow conferencing capabilities on that CO line.

Only stations that have Conference enabled will be able to initiate a conference on a CO line with conference enabled.

The Conference mark on the CO line will govern a DISA callers ability to access other outside lines. CO lines must have conference enabled to allow a trunk-to-trunk DISA call.

Conference is enabled for all CO lines in default.

Related Programming: Station Attributes (Flash 50) for Conference feature

DTMF	CO	UNA	SUPV
DISA	FLASH	GROUP	COS
RING ASSIGN	FWD	BACK	SLCT
CONF	PRIV		

K. Automatic Privacy

Programming Steps

To program Automatic Privacy:

1. Press the PRIV flexible button. (Button #14).
 - LED on = Automatic Privacy is enabled
 - LED off = Automatic Privacy is disabled
2. Press HOLD button. Display will now update.

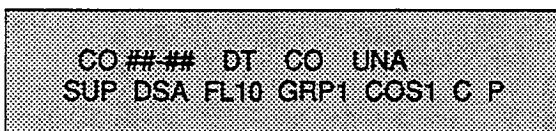

Description

If desired, the system can be programmed to eliminate CO Line privacy, allowing another station to join in on existing outside line conversations.

Stations must have a direct CO line appearance to join CO line conversations in progress.

A station must also have Privacy disabled before the system will allow that station to enter into an existing conversation.

Both parties will hear an alert tone just prior to a station joining the call.

When privacy is disabled, only one other station may join in on an existing conversation.

Default: By default, Automatic Privacy is enabled for all CO Lines.

Related Programming: Automatic Privacy option and button assignments in Station Attributes (Flash 50) programming.

NOTE: A decrease in volume may occur after a station joins an existing conversation.

SECTION 630

STATION ATTRIBUTES PROGRAMMING

630.1 STATION PROGRAMMING

Programming Steps

If the system is in the programming mode, continue using program codes. If starting to program here, enter the programming mode first (Refer to Paragraph 600.3).

If station features are to be changed:

- A. Press FLASH and dial [50]. The following message is shown on the display phone:

STATION ATTRIBUTES
SELECT A STATION RANGE

- B. Program button twelve (SLCT) will be lit. Enter a six digit number (100-195) for station range being programmed. If only one station is being programmed, enter that number twice i.e. (100100).
- C. Press HOLD button.
- D. The display updates to current programming for Page A:

XXX-XXX A PAGE DND LCOS0
SPD QUE PLA EO FWD LCR C

Where:

- XXX= Station Range
- A= Page "A" Features
- PAGE= Paging Access is allowed
- DND= Do Not Disturb is allowed
- LCOS= LCR COS Assignment (0-6)
- SPD= System Speed Dial allowed
- QUE= Line Queuing is allowed
- PLA= Preferred Line Answer is allowed
- EO= Executive Override is allowed
- FWD= Call Forward is allowed
- LCR= Forced LCR Enabled
- C= Conference is allowed

Description

This section describes the steps and procedures necessary to program station attributes for stations connected to the 96EX hybrid key telephone system. When entering the Station attributes portion of the data base the programmer may decide to enter information for either a range of stations or one specific station.

Range programming allows the programmer to change a specific parameter or a few parameters for an entire range of stations leaving intact the remaining data fields that do not require change. Those data fields will continue to operate with the previously programmed data. For example if station data varies from station to station i.e. button data is different or Class-of-service assignments are different etc... but it is desired to enable Preferred Line Answer (PLA) for all stations the programmer may enter as the range ALL stations (100-195) and enable PLA, then exit programming. This will enable PLA for all stations leaving intact the various other station programming for the range.

Station Attributes are divided between those features that require either a simple allow/deny or Enable/Disable (toggle) operation and those that require a numeric entry. The allow/deny (toggle) type features are programmed on page "A". Entries that require a numeric entry i.e. Station ID, COS etc... are programmed on page "B". When Station Attribute programming is entered, Page "A" features are displayed and ready for programming. To program a parameter in Page "B", it is necessary to press button #11 (PG B).

When programming the Page A features, the flexible buttons are mapped as follows:

PAGE	DND	SPEED	QUE
PLA	EXEC	FWD	FLCR
LCOS	PG A	PG B	SLCT
CONF			

- PG A button selects Page A features
- PG B button selects Page B features

STATION PROGRAMMING (Cont'd)

A. Paging Access

Programming Steps

1. Press the PAGE flexible button (Page A, Button #1).
 - LED on = Paging is allowed
 - LED off= Paging is denied
2. Press the HOLD button to enter data.

Description

PAGE. Stations can individually be allowed or denied the ability to make pages. This applies to all internal and external zone paging. A station denied access to paging may still answer a meet-me page announcement. (Station COS 6 will not deny a station the ability to make a page.)

Default: By default, Paging is allowed at all stations.

B. Do Not Disturb

Programming Steps

1. Press the DND flexible button (Page A, Button #2).
 - LED on = Do Not Disturb is allowed
 - LED off= Do Not Disturb is denied
2. Press the HOLD button to enter data.

Description

DND. Stations can be individually allowed or denied the ability to place their telephone in Do Not Disturb.

Default: By default, Do Not Disturb is allowed at all stations.

C. Speed Dialing Access

Programming Steps

1. Press the SPEED flexible button (Page A, Button #3).
 - LED on = Speed Dialing access is allowed
 - LED off= Speed Dialing access is denied
2. Press the HOLD button to enter data.

Description

SPEED. Stations can be individually allowed or denied the ability to use system speed dial numbers. The last forty system speed numbers are not monitored by toll restriction, refer to toll restriction programming. Stations can not be prevented from using station speed dial.

Default: By default, Speed Dialing is allowed at all stations.

D. Line Queuing

Programming Steps

1. Press the QUE flexible button (Page A, Button #4).
 - LED on = Queuing is allowed
 - LED off= Queuing is denied
2. Press the HOLD button to enter data.

Description

QUE. Stations can be allowed or denied the ability to manually queue for a busy group of CO lines. Even when disabled, stations will have automatic LCR queuing privileges.

Default: By default, CO Line Queuing is allowed at all stations.

STATION PROGRAMMING (Cont'd)

E. Preferred Line Answer

Programming Steps

1. Press the PLA flexible button (Page A, Button #5).
 - LED on = Preferred Line Answer is allowed
 - LED off= Preferred Line Answer is denied
2. Press the HOLD button to enter data.

Description

PLA. Stations can be given the ability to answer incoming outside line calls, transferred and recalling lines and line queues by simply going off-hook. (Preferred Line Answer)

Default: By default, Preferred Line Answer is disallowed on all stations.

F. Executive Override

Programming Steps

1. Press the EXEC flexible button (Page A, Button #6).
 - LED on = Executive Override is allowed
 - LED off= Executive Override is denied
2. Press the HOLD button to enter data.

Description

EXEC. This feature allows certain stations to be designated as "Executive" stations with the ability to override and "barge-in" on other keysets engaged in CO line conversation. If an extension is engaged in an intercom conversation the call can be overridden but the intercom connection will be dropped. This is a useful feature for UCD agent supervisors or for alternate answering positions.

An optional warning tone is programmed on a system wide basis to either enable or disable the tone. This tone will be presented to all parties prior to actual cut thru of the third party.

Default: By default, Executive Override is disabled for all stations.

Related Programming: Executive Override Warning Tone.

NOTE: A decrease in volume may occur after a station joins an existing CO Line conversation.

CAUTION: USE OF THIS FEATURE WHEN THE EXECUTIVE OVERRIDE WARNING TONE IS DISABLED MAY BE INTERPRETED AS A VIOLATION OF FEDERAL OR STATE LAWS, AND AN INVASION OF PRIVACY. CONSULT COUNSEL WITH RESPECT TO APPLICABLE LAW BEFORE INTRUDING ON CALLS USING THIS FEATURE.

G. Call Forwarding

Programming Steps

1. Press the FWD flexible button (Page A, Button #7).
 - LED on = Call Forwarding is allowed
 - LED off= Call Forwarding is denied
2. Press the HOLD button to enter data.

Description

FWD. Stations can be allowed or denied the ability to have incoming CO calls, intercom, transferred outside lines forwarded to another station, UCD, Hunt or Voice Mail group or Off-Net Forward via speed dial.

Default: By default, Call Forwarding is allowed at all stations.

STATION PROGRAMMING (Cont'd)

H. Least Cost Routing - Forced

Programming Steps

1. Press the FLCR flexible button (Page A, Button #8).
 - LED on = Least Cost Routing is forced
 - LED off = Least Cost Routing is optional
2. Press the HOLD button to enter data.

Description

FLCR. Stations may be forced to place outgoing CO calls by use of LCR (dial [9]) to access an outside line). This allows the system administrator to control dialing patterns and the lines used for outgoing CO calls more effectively. This can be enabled/disabled on a per station basis for additional flexibility and control.

Default: LCR is optional for all stations.

Related Programming: LCR Class of Service (below), LCR Enable/Disable (Sec. 610.23), and LCR programming (Sec. 650).

I. LCR Class of Service

Programming Steps

1. Press the LCOS flexible button (Page A, Button #9).
2. Enter a one-digit number between 0 and 6 to correspond to the LCR Class of Service desired.
3. Press the HOLD button to enter data.

Description

LCOS. Stations can be given a class of service assignment for Least Cost Routing. The range is between 0 and 6 with 0 being unrestricted and 6 being the most restricted. A station will be allowed use of LCR routes with a priority number equal to or higher than the stations LCR COS assignment.

Default: By default, all stations are given unrestricted access (0).

Related Programming: LCR Route List Table programming.

J. Conference Enable/Disable (Per Station)

Programming Steps

1. Press the CONF flexible button (Page A, Button #13).
 - LED on = Conference is enabled
 - LED off = Conference is disabled
2. Press HOLD button. Display will now update.

Description

CONF. This feature allows the system to be programmed on a per Station basis for the ability to initiate a conference.

Only stations that have Conference enabled will be able to initiate a conference.

When attempting to establish a multi-line conference, the CO line must also have conference capabilities

A station that is denied conferencing capabilities in programming can be a party to another stations conference provided that station does have conferencing privileges.

Default: By default, Conference is enabled for all stations.

Related Programming: CO Line Attributes programming for Conference capabilities.

STATION PROGRAMMING (Cont'd)

Page B Feature Programming

Programming Steps

The remaining station features are located and programmed on Page B.

- A. Press [PG B] button. The display of current programming for those features will appear as follows:

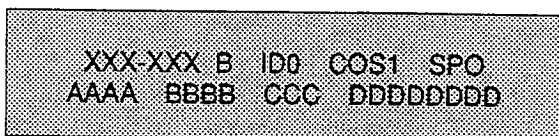

Where:

- XXX= Station Range
- B= Page "B" Features
- ID= Station Identification (0-9)
- COS= Class of Service (1-6)
- SPK= Speakerphone Option (0-2)
 - A= Pickup Group (1-4)
 - B= Paging Zone (1-4)
- CC= Preset Forward Destination
- DD= CO Line Group access

K. Type of Station Programming

Programming Steps

1. Press the ID flexible button (Page B, Button #1).
 2. Enter a one-to-four digit number to identify the type of station.
 - 0 = Enhanced or Executive Key telephone
 - 1xxx = DSS Console MAP 1 (Figure 630-1)
 - 2xxx = DSS Console MAP 2 (Figure 630-1)
 - 3xxx = DSS Console MAP 3 (Figure 630-1)
 - 40 = Phone Box w/o BGM
 - 41 = Phone Box with BGM
 - 5= SLT or OPX
 - 6= SLT with Message Waiting Lamp
 - 7= Basic Key Telephone
 - 8xxx= DSS Console Map 4 (Figure 630-2)
 - 9xxx= DSS Console Map 5 (Figure 630-2)
- xxx= three-digit station number the DSS Console is associated with.
3. Press the HOLD button to enter data.

Description

When programming Page B features, the flexible buttons are mapped as follows:

ID	COS	SPK	PKUP
PAGE	PREFW	ACC	FLEX
DSP	PG A	PG B	SLCT
PRIV	OHP		

NOTE: Features programmed in Page "B" require a numeric entry after pressing the flexible button.

Description

ID. Each system port must be programmed to identify the type of station that will operate on that port. Each station type must be identified.

Default: By default, all KIB's default to ID 0 (Enhanced, Executive telephone), all SLT's default to ID 5 (SLT or OPX).

CO Line ringing on Map 1,3, and 5 is determined by CO Line Attributes (Flash 40), CO Line Ringing Assignments

NOTE: When identifying a station as a DSS/DLS Console, you must also enter the station number of the Key Telephone the DSS/DLS Console is attached to.

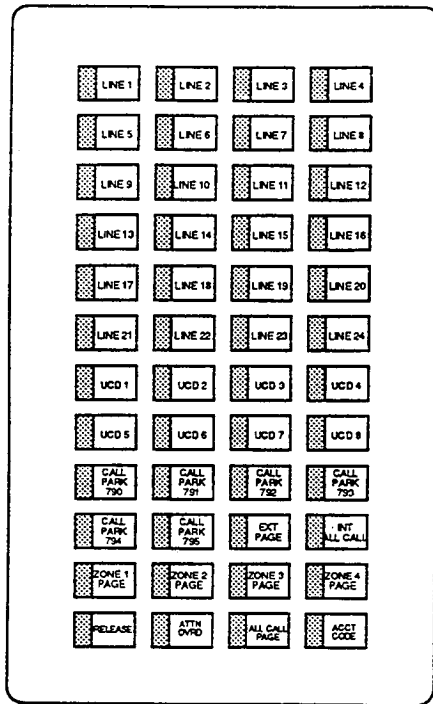

DSS Console Map 1

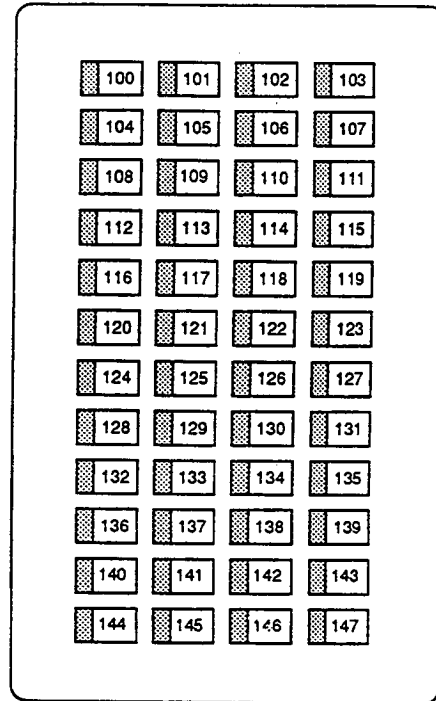

DSS Console Map 2

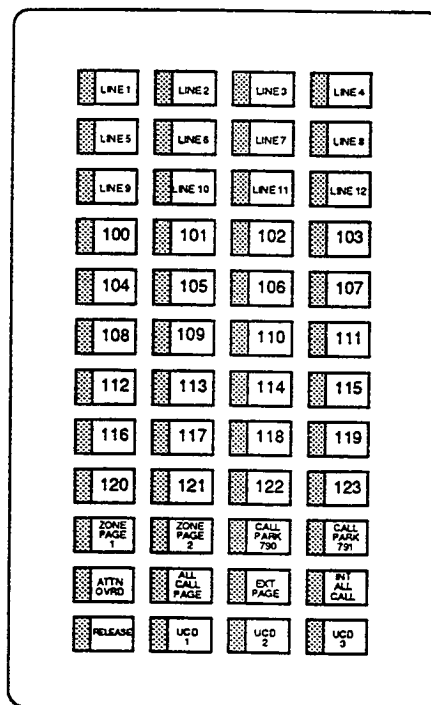

DSS Console Map 3

Figure 630-1 DSS Console Maps 1-3 Button Assignment

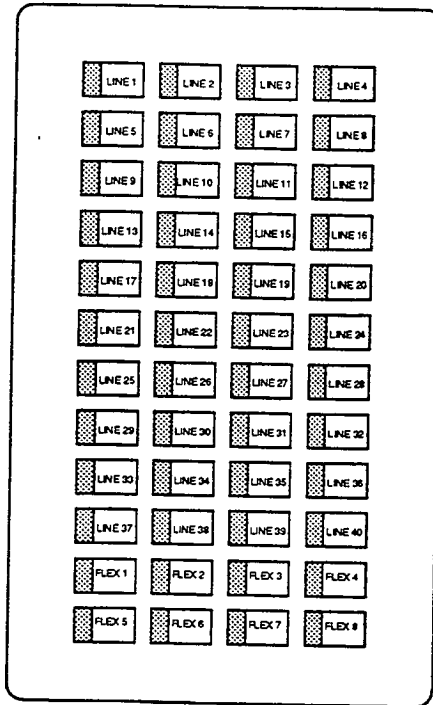

DSS Console Map 4

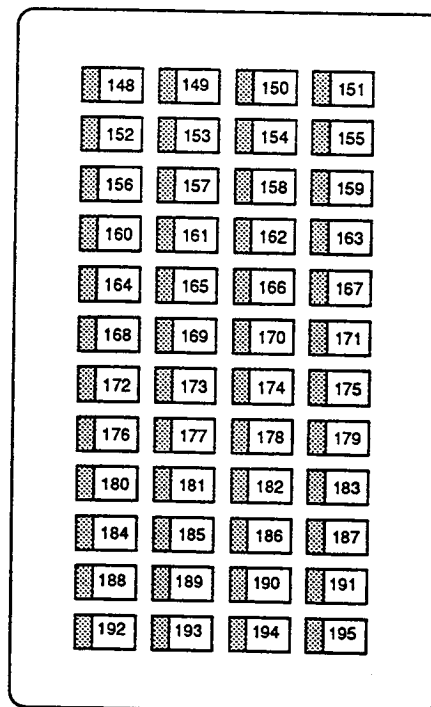

DSS Console Map 5

Figure 630-2 DSS Console Maps 4 & 5 Button Assignment

STATION PROGRAMMING (Cont'd)

L. Station Class of Service (COS)

Programming Steps

1. Press the COS flexible button (Page B, Button #2).
2. Enter a two-digit Class of Service entry as follows:
 - 1st digit is day COS
 - 2nd digit is night COS

The six classes of service are:

- 1= unrestricted
- 2= governed by Table A
- 3= governed by Table B
- 4= governed by Tables A and B
- 5= no 0,1,*,# as first digit, 7 digits max.
- 6= intercom only (no CO Line access)

3. Press the HOLD button to enter data. Display will now update.

Description

COS. Each stations must be assigned a certain COS for day mode operation, and also be assigned a COS for night mode operation. The night COS goes into affect when the system is placed into the night mode, manually or automatically. This prevents the misuse of phones after hours.

Class of service (COS) determines the stations dialing privileges. Refer to Table 620-1.

Default: By default, all stations are assigned a COS 1 for day mode and COS 1 for night mode.

Related Programming: CO Line Attributes (Sec. 620), Class of Service programming (Sec. 620), Exception Tables programming (Sec. 640).

M. Speakerphone Programming

Programming Steps

1. Press the SPK flexible button (Page B, Button #3).
2. Enter a one-digit number between 0 and 2 to identify the speakerphone operation.
 - 0 = works as normal speakerphone
 - 1 = intercom calls enabled, outgoing calls disabled
 - 2 = allows, headset operation
3. Press the HOLD button to enter data.

Description

SPK. Each telephone's speakerphone ability is programmable in one of three ways.

A speakerphone ID of 2 will allow the station user to enable headset mode by dialing a code. The station user may then return to full speakerphone operation by dialing the same code again.

Default: By default, all stations are assigned an ID of 0.

STATION PROGRAMMING (Cont'd)

N. Pick-Up Group(s) Programming

<u>Programming Steps</u>	<u>Description</u>
<ol style="list-style-type: none">1. Press the PKUP flexible button (Page B, Button #4).2. Enter a one-to-four digit number to program pickup groups.<ul style="list-style-type: none">0= no group1= Group 12= Group 23= Group 34= Group 43. Press the HOLD button to enter data.	<p>PKUP. Each station is assigned into pick up groups. Stations can be in any combination of the four groups or in no group at all.</p> <p>Default: By default, all stations are in group 1.</p>

O. Paging Zone(s) Programming

<u>Programming Steps</u>	<u>Description</u>
<ol style="list-style-type: none">1. Press the PAGE flexible button (Page B, Button #5).2. Enter a one-to-four digit number to program paging zone(s).<ul style="list-style-type: none">0= no zone (no pages received)1= Zone 12= Zone 23= Zone 34= Zone 43. Press the HOLD button to enter data.	<p>PAGE. Each station is assigned to internal paging zones. A station can be in any or all zones or in no zone at all.</p> <p>All Call is all page zones combined. If a station is not in any internal zone, it will not receive any all call pages.</p> <p>Stations not assigned to a page group can still make page announcements if allowed in station programming. Stations can be assigned to a page group in order to receive pages but not allowed to make pages.</p> <p>Default: By default, all stations are in page zone 1.</p>

STATION PROGRAMMING (Cont'd)

P. Preset Call Forward Programming

Programming Steps

1. Press the PREFW flexible button (Page B, Button #6).
2. Enter a three-digit number to determine the destination where calls are to be routed when the preset forward timer expires.
Valid 3 digit destinations are:
 020-099= System Speed Bins 20-99 for off-net forwarding
 100-195= Station Numbers
 590-597= Hunt Groups 1-8
 690-697= Voice Mail Groups 1-8
 890-897= UCD Groups 1-8
3. Press the HOLD button to enter data. Display now updates.

ID	COS	SPK	PKUP
PAGE	PREFW	ACC	FLEX
DSP	PG A	PG B	SLCT
AUTO PRIVACY			

Description

PREFW. This feature allows the system database to be configured so that incoming CO Lines, which are programmed to ring at a particular station, can be forwarded elsewhere in the system predetermined by programming. This feature is active if the station ringing is not answered in a specified time. This is particularly useful in "overflow" applications where a Voice Mail or Auto Attendant may be in use.

A station may have one designated preset forward location defined in the database.

Preset Call Forward is chainable only to other predetermined preset forward stations specified in the database up to a chain of 5 stations. If a CO Line forwarded by Preset Call Forward encounters a manually forwarded station (Call Forward - Station), or a station in DND, then the incoming CO Line will bypass that station and forward to the next in the chain. If that station is the last in the chain, then the call will not forward any further and will continue to ring at that station until answered or terminated.

Chainable Preset Call Forwarding will force the incoming CO Line to ring at each station preassigned in the database for the Preset Forward Ring Timer, specified in the database, before forwarding.

CO Lines can be preset forwarded to ring into a UCD, Voice Mail, Hunt Group or Off-Net via speed dial from any station. A CO line will not preset forward to a busy hunt, voice mail, or UCD group, however each time the preset forward timer expires (for a total of five attempts) the group will be checked for an idle station. If a member of the group is idle the call will then be presented to that member.

Default: By default, no preset forward destinations are programmed.

Related Programming: Call Forward Preset Timer.

STATION PROGRAMMING (Cont'd)

Q. CO Line Group Access

Programming Steps

1. Press the ACC flexible button (Page B, Button #7).
2. Enter up to seven digits (0, or 1-7) for the outside line groups the station will have access to.
 - 0 =no access
 - 1 =access to Group 1, Code 9 or 81
 - 2 =access to Group 2, Code 82
 - 3 =access to Group 3, Code 83
 - 4 =access to Group 4, Code 84
 - 5 =access to Group 5, Code 85
 - 6 =access to Group 6, Code 86
 - 7 =access to Group 7, Code 87
3. Press the HOLD button to enter data.

Description

ACC. A station is allowed access to any combination of outside line groups. Or a station may not be allowed any access to outside lines. The following are the line group numbers and their access codes. CO line groups are used primarily by single line telephones or for flexible buttons assigned as pooled group buttons on a Key Telephone.

Default: By default, all stations are allowed access to all groups.

Related Programming: CO Line Group programming.

R. Flexible Button Programming

Programming Steps

1. Press the FLEX flexible button (Page 3, Button #8). The following message is shown on the display phone:

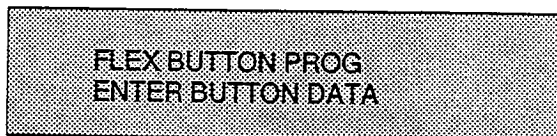

2. Enter the button information as follows:
where: BB= Button number (01-22)
To assign a button as a multi-function button (user programmable) enter:
BB [0] HOLD
To assign a button as a CO Line button, enter:
BB [1] LL HOLD (LL=CO Line 01-40)
To assign a button as a Loop button, enter:
BB [2] HOLD
To assign a button as a pooled group button, enter:
BB [3] G HOLD (G= Line Group # 1-7)
To unassign a button, rendering it inoperable, enter:
BB [#] HOLD

SLT. If SLT stations are to be programmed for Off-Hook Preference it is necessary to program the CO line, or CO line group, the SLT is to access when going off-hook here. Enter 00 for the button number followed by either a [1] for CO line access (01-40), or a [3] to assign CO line group (CO Line Group 1-7).

Description

FLEX. When programming flexible buttons, first enter the two digit button number to be programmed (01 to 22).

MULTI. When a button is assigned as a multi-function button [0], the user then has the ability to program any features or functions on the buttons that the user has access to. For a complete list of user programmable code (functions and features), refer to Table 630-1.

CO. When programming a button as a CO line button, refer to CO line ringing. By default station 100 will ring on a line. However, if station 100 is not given button access to a line, another station must be programmed to ring on that line.

NOTE: The ring status assignments are done in CO Line Attributes (Sec. 620).

LOOP. All stations should be given a loop button so they can receive a transferred call on a line for which they have no button access.

POOL. When programming a button as a pooled group button, refer to CO line group programming. Pooled group numbers match CO line group numbers.

Related Programming: CO Line Ring Assignments (Sec. 620), Off-Hook Preference (see below).

STATION PROGRAMMING (Cont'd)

S. Display Flexible Buttons

Programming Steps

1. Press the DSP flexible button (Page B, Button #9).
2. The programming assignment on four buttons will be displayed starting with the lowest button number. With each sub-sequent depression of the DSP button the next four buttons will be displayed. The following message is shown on the display:

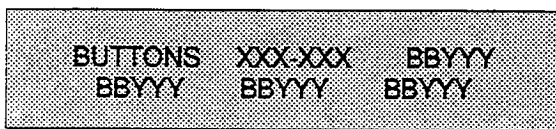

Description

DSP. Any time a display of button programming (default or changed) is needed, press the DSP button (button 9) on Page B and it will display four buttons' programming assignments (starting with the lowest button number). With each subsequent depression of the DSP button the next four buttons will be displayed.

When a button is assigned as a multi-function button [0], the user then has the ability to program any features or functions on the buttons that the user has access to. For a complete list of user programmable code (functions and features), refer to Sec. 200.59.

Where:

XXX= Station number

BB= Button Number

YY= Button function (see table below)

Table 630-1 Flexible Button Display Designations

<p>MUL= Multi-function button: A button which has not been given a function by the user.</p> <p>D[XXX]= Station button and station number. If the number is between 890 and 897, it is a UCD group button.</p> <p>S[YY]= Speed bin and bin number.</p> <p>LP= Loop Button.</p> <p>PL[G]= Pooled group and CO Line Group number.</p> <p>MUS= Background Music button.</p> <p>LNR= Last Number Redial button.</p> <p>SNR= Save Number Redial button.</p> <p>H[HH]= Hunt Group and Pilot number.</p> <p>M[ZZ]= Personalized Message and message number.</p> <p>V[VV]= Voice Mail Group and Pilot number.</p> <p>ACC= Account Code enter.</p> <p>CP[C]= Call Park and Parking location.</p> <p>ACP= All Call Page button.</p> <p>CBK= Call Back button.</p> <p>PUP= Pickup button.</p> <p>MUT= Mute button.</p> <p>LQU= Line Queue button.</p> <p>DND= Do Not Disturb button.</p>	<p>CON= Camp-On button.</p> <p>HST= Headset mode.</p> <p>AVL= Available/Unavailable button.</p> <p>CIQ= UCD Calls in Queue.</p> <p>PPK= Personal Park button.</p> <p>IP[N]= Internal Page and Zone number.</p> <p>IAC= Internal All Call Page button.</p> <p>EPG= External Page button.</p> <p>MMP= Meet Me page answer button.</p> <p>EOR= Executive Override button.</p> <p>AOR= Attendant Override button.</p> <p>[LL]= CO Line</p> <p><i>XXX= Station Number</i></p> <p><i>YY= Speed Dial Bin</i></p> <p><i>G= Pool or CO Line Group number</i></p> <p><i>HH= Hunt Group number</i></p> <p><i>ZZ= Personalized Message number</i></p> <p><i>VV= Voice Mail Group number</i></p> <p><i>C= Call Park location</i></p> <p><i>N= Page Zone number</i></p> <p><i>LL= CO Lines 01-40</i></p>
---	---

STATION PROGRAMMING (Cont'd)

T. Automatic Privacy (Per Station)

Programming Steps

To program station(s) for Automatic Privacy:

1. Press the PRIV flexible button (Page B, Button #13).
 - LED on = Automatic Privacy is enabled on Stations(s)
 - LED off = Automatic Privacy is disabled on Station(s)
2. Press HOLD button. Display now updates.

NOTE: There is NO verification on the LCD display when Automatic Privacy is enabled in Station Attributes. Use the LED for verification.

Description

PRIV. If desired, the system can be programmed to eliminate privacy, allowing another station to join in on existing outside line conversations. Each station can be programmed for privacy allowing the station to join an existing conversation by simply pressing a CO line button of a CO line in use.

Both the station and the CO line must have privacy disabled before the system will allow cut-thru.

If privacy is disabled and a station joins an existing call, both parties will hear an alert tone.

If privacy is disabled, only one other station may join in on an existing conversation.

Default: Automatic Privacy is enabled for all stations in default.

Related Programming: CO Line Attributes (Flash 40) programming: Privacy feature.

NOTE: A decrease in volume may occur after a station joins an existing CO Line conversation.

ID	COS	SPK	PKUP
PAGE	PREFW	ACC	FLEX
DSP	PG A	PG B	SLCT
PRIV	OHP		

STATION PROGRAMMING (Cont'd)

U. Off-Hook Preference Programming

Programming Steps

To program a station for Off-Hook Preference;

1. Press the OHP flexible button (Page B, Button#14). The following message is shown on the display phone:

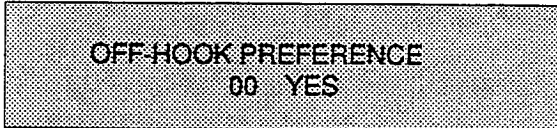

OFF-HOOK PREFERENCE
00 YES

2. Enter the two-digit button number (01-22) or (00) to indicate no specific button is preferred. SLT's use 01 to enable or 00 to disable.
3. Then, enter either 0 or 1 where:
 - 0 = Disable user programmable preference so that users may not change the off-hook preference as set in programming. Also use for SLT stations.
 - 1 = Enable user programmable preference to key station users so that they may change the off-hook preference through a user dial code
4. Press the HOLD button. The display will now update.

Description

OHP. This allows a key station user to automatically have a flex button selected when going off-hook or when pressing the ON/OFF button. SLT user may have a particular CO line or a CO line group selected automatically when going off-hook.

This may be established in programming so that key station users may select and/or change their off-hook preference through the use of a dial code. This user programmable preference may be allowed or denied in programming.

When establishing an off-hook preference for SLT stations it is necessary to program the SLT's CO line, or line group, to be accessed when going off-hook, first using a flex button programming procedure. Refer to Flex Button programming (Button #8) for instructions described earlier in this section.

Default: By default, all key stations are allowed to change their preference but no button is assigned (00). SLT stations are not allowed this feature.

Related Programming: Refer to Flex Button Programming.

SECTION 640

EXCEPTION TABLES PROGRAMMING

640.1 INTRODUCTION

Programming Steps

The 96EX Hybrid Key Telephone System offers a flexible means of applying toll restriction to stations or individuals. Dialing privileges (or toll restriction) is determined through assignment of station and CO line Class Of Service (COS). Several types of restriction can be derived simply by programming COS assignments and CO line access to stations. This may, in some cases, be all that is necessary. However, when a more complex or specific type of restriction is desired the system offers two allow and two deny tables along with four special tables. These tables can be programmed in a variety of ways to handle applications that are straight forward or applications that require a more complex arrangement.

The allow and deny tables are assigned to stations based on their station Class of Service (COS) assignment. The Station (COS) interacts with CO Line COS assignments to provide several different types of dialing privileges (Refer to CO/Station COS matrix below).

The Allow and Deny tables allow entries of either general or specific allow and deny codes such as allowing all [1-800] type calls, and/or denying all [1]+ or [0]+ calls. The allow and deny tables allow a maximum of eight digits to be entered as allow or deny digits. This allows for entry of certain area codes or office codes or a combination of area code

plus office code that can specifically be allowed or denied. For example the code [1 555-1212] may be entered in the deny table to deny local toll information calls. Each allow table contains twenty (20) bins for entry of allow codes. The deny tables allow for ten (10) entries of deny codes, in each table.

The following rules should be remembered when setting up the Allow/Deny tables (Refer to Table 640-2).

1. If both tables (allow and deny) have no entries, no restriction is applied.
2. If entries are made in the allow table and only there, then only those numbers are allowed. All other dialing is denied.
3. If entries are made in the deny table and only there, then only those numbers are denied. All other dialing is allowed.
4. If there are entries in both allow and deny tables, the allow table is searched first and if a match is found, it is allowed. If a match is not found, the deny table is searched and if a match is found there, the call is denied. If the number does not match an entry in either table, it is allowed.

A special "Don't Care" ("D") character may be entered as a digit to either allow or deny any digit dialed in that digit sequence. For example a code [1 "D" 0] and [1 "D" 1] may be entered in the deny table which would allow local long distance calls (numbers dialed with a 1 followed by a seven digit local number), but would deny long distance calls (numbers dialed with

Table 640-1 Class of Service (COS)

S T A C O S	CO LINE CLASS OF SERVICE					
	1	2	3	4	5	
1	Unrestricted	Unrestricted	Unrestricted	Canned Restriction*	Unrestricted	
2	Table A	Table A	Unrestricted	Canned Restriction	Unrestricted	
3	Table B	Unrestricted	Table B	Canned Restriction	Unrestricted	
4	Tables A&B	Table A	Table B	Canned Restriction	Unrestricted	
5	Canned Restriction	Canned Restriction	Canned Restriction	Canned Restriction	Unrestricted	
6	Intercom only	Intercom only	Intercom only	Intercom only	Intercom only	
Canned Restriction= No '0', 1, #, '' as a first dialed digit, and 7 digits maximum plus 1-800, 1911, 1611 are allowed and 411, 976, and 555 numbers are denied.						

Table 640-2 Allow/Deny Toll Table

	ALLOW TABLE	DENY TABLE	CONDITIONS AND RESULTS			
			DIALED NO.	A/D	DIALED NO.	A/D
RULE 1	NO ENTRIES	NO ENTRIES	ALLOW			
RULE 2	NO ENTRIES	NO ENTRIES	FOUND	A		
			NOT FOUND	D		
RULE 3	NO ENTRIES	NO ENTRIES			FOUND	D
					NOT FOUND	A
RULE 4	ENTRIES	ENTRIES	FOUND	A		
			NOT FOUND	D		
			FOUND	A	FOUND	D
			NOT FOUND	D	NOT FOUND	A
			ALLOW TABLE		DENY TABLE	

a 1 followed by an area code).

The 96EX system also offers four (4) special tables that can be referenced from within the two allow tables. Three of the special tables can be assigned to specific area codes that require further toll restriction definition. The fourth special table is reserved for use as a home area code table (numbers within the same area code as the site where the system is installed). This provides expanded ability to apply toll restriction on numbers that are dialed within an area code. Each special table will allow up to (800) entries (200-999). This offers the ability to allow every office code on an individual basis

640.2 RELATED ITEMS TO TOLL RESTRICTION

A. CO/PBX Lines

When CO lines are marked as PBX lines (refer to CO line programming sec. 620) the system will first check the PBX code table (refer to sec. 610.17) for a valid match. If the first digits dialed do not match the entries in the PBX code table the call is considered an attempt to call another PBX extension and no toll restriction is applied. If the first digits dialed are found in the PBX code table then toll restriction will start with the next dialed digit.

B. Forced Account Codes

The system can optionally force the use of account codes on all restricted calls. When forced account codes are enabled (see sec. 610.20) an account code must be entered to place a call that is otherwise

restricted through toll restriction. By entering an account code the stations effective class of service becomes that equal to class of service 1 (unrestricted).

When account codes are forced on a system wide basis selected users may be instructed on how to enter account codes from any station and be allowed to dial unrestricted from a station that may otherwise be restricted. Use of account codes in this manner, as a traveling class-of-service, is however not controlled by the system. Any station user with knowledge of how to enter account codes to override a stations toll restriction will be allowed to do so.

C. SLT DTMF Receivers

When single line telephones are connected to the 96EX system and toll restriction is enabled the system DTMF receivers located on the APL board will monitor the call for a programmed period of time (refer to Sec. 610.40, SLT Receiver Timer). While the DTMF receiver is monitoring the digits being dialed, by a single line telephone, it is considered busy and not available for monitoring another SLT attempting to dial. When all DTMF receivers are busy, an SLT attempting to go off-hook will not receive dial tone until a receiver is available. The system has up to six (6) DTMF receivers (two (2) standard on the APL and four (4) optional on the SLU) for monitoring SLT dialing. If a system has heavy SLT usage toll restriction may inhibit dialing by SLT stations. Two options are available to help alleviate this problem; 1) shorten the SLT receiver timer(see section 610.40). This will free up DTMF receivers faster, however, may not provide the desired toll restriction for SLT stations; 2) Enable LCR and force LCR on SLT stations. When the LCR data base is set up the three digit table allows for entry of the number of digits to be expected. When a SLT dials the appropriate number of digits LCR will release the DTMF receiver and then be available for another SLT call.

D. LCR VS. Toll Restriction

LCR is not intended to be an alternative to toll restriction nor is toll restriction intended to be an alternate to LCR. In fact they both work best when programmed together. Toll restriction provides the dialing privileges that stations are allowed and LCR provides the routing of calls onto the proper type of lines. LCR can enhance toll restriction in that LCR provides a "Store and Forward" operation that allows the system to analyze the digits being dialed before a trunk is seized. This prevents users from by-passing toll restriction by taking advantage of the time it takes for a central office line to provide dial tone. Because of this it is recommended that LCR be considered when toll restriction is desired.

640.3 TOLL RESTRICTION PROGRAMMING

A. Entering Toll Table Programming

Programming Steps

If the system is in the programming mode, continue using program codes. If starting to program here, enter the programming mode first (See Paragraph 600.3)

NOTE: It is recommended that the Exception Tables be initialized prior to entering data into the tables. Do this by following the instructions in Sec. 600.4 for initializing the Exception Tables (Flash 73). This procedure may also be repeated if it is determined that data in the exception tables has become corrupt. However, after initializing the exception tables, for this purpose, all data must be re-entered into the tables.

1. Press FLASH and dial [60]. The following message will be shown on the display phone:

EXCEPTION TABLES
SELECT A TABLE

2. To program allow / deny tables press the appropriate button and enter information as outlined in the following procedures.
3. To program special tables 1-3 it is necessary to associate an area code to the table. Do this by pressing the appropriate "AREA-X" button and assign the area code.

NOTE: Special Table 4 is reserved for the home area code and does not require a area code entry.

4. To display entries in any of the tables press the DISP button (button #9). Entries in the allow / deny tables will display two at a time. Entries in the special tables will be displayed six (6) at a time in ascending order.

Description

All toll tables have been conveniently placed under one program code to allow entry of all toll restriction data. When entering toll information the buttons on the phone will be mapped as follows:

ALL-A	DEN-A	ALL-B	DEN-B
ST-1	ST-2	ST-3	ST-4
AREA 1	AREA 2	AREA 3	DISP

When the system searches the allow and deny tables, the entries are looked at starting at Bin 01 and proceeding sequentially through the table to the last bin. In addition The allow table is always searched before looking at the deny table. Therefore the order of entry is important. Entries that are specific (i.e. [1 716]) should be placed ahead of entries that are more general (usually include "Don't Care" digits i.e. [1 "D" 1]).

Once a match is found, in the allow table, that references a special table the number dialed will be checked for an allowed code in the special table. If a match is not found in the special table the system will continue to check for a match in the next allow or deny table that is to be checked. The system will not return to the table that sent the call to the special table.

Exception Tables Programming (Cont'd)

B. Allow Table Programming

Programming Steps

1. Press the ALL-A or ALL-B flexible button (Button #1 or #3). The following display will be shown on the display telephone:

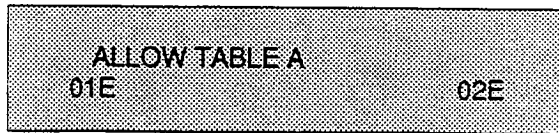

The first two bins locations are displayed.

2. Dial on the dial pad the two-digit bin number (01-20) the allow code is to be entered into.

NOTE: It is recommended that; bin 17 be reserved for an entry that will reference special table number 1; and bin 18 be reserved for an entry that will reference special table number 2; and bin 19 be reserved for referencing special table number 3; and bin 20 be reserved for referencing the Home area code table, special table number 4.

3. Dial the allow code where:

0 to 9, *, # = corresponding allow digits (numbers)

DND = Don't Care digit ("D")

TRANS = search special table ("S")

4. Press HOLD button after each entry.

5. When all entries for one table are complete, press the flexible button for the next table.

The following rules should be applied when making entries that will reference the special tables:

1. For entries referencing the first three special tables a specific area code must be identified (one for each table needed). Then make note as to how the numbers will be dialed when dialing numbers to this area code (i.e. with a leading digit [1] or no leading digit [1]). The entry into the allow table would be entered as follows:

Leading digit [1] - BB 1 XXX DDD {S}

or

Non Leading [1] - BB XXX DDD {S}

Where;

BB = Bin number (recommended 17-19)

XXX = Area code (must match AREA-X entry)

DDD = "Don't Care" digit (three entries, DND button)

{S} = Search Special Table Command
(TRANS button)

Description

Allow Table - Each Allow table contains twenty (20) bin numbers. Each bin number may be up to eight (8) digits in length including {Don't Care} digits and {Search Special Table} commands. Entries into the allow table represent exceptions to numbers or codes that are to be allowed only if they would otherwise be restricted by an entry in the deny table. For example if [1 555 1212] is to be allowed but [1+] numbers are denied, by an entry into the deny table, then [1 555 1212] should be entered into the allow table as an allowed number.

- Allow table A is referenced and searched first (before the deny table A) when Station COS is 2 and CO line COS is either 1 or 2.
- Allow table B is referenced and looked at first (before the deny table B) when Station COS is 3 and CO line COS is either 1 or 3.
- When station COS is 4 and CO line COS is 1 both allow tables are looked at first (allow table A first then allow table B) then both deny tables (deny table A first then deny table B).

Don't Care digits specify that the system should consider any digit dialed in that position as a match. Don't Care digits should not be entered as the last digit in an entry, as this would be an unnecessary or meaningless command.

Search Special Table commands must be entered in a specific manner and should always be placed as the last entries in the Allow table. It is recommended that the last four bins (17-20) in the allow table be reserved for referencing the four (4) special tables with the reference to the home area code (special table 4) always being located in bin number 20. Search Special table commands can only be entered into the allow tables.

To erase a bin, enter the two-digit bin number following by pressing the HOLD button.

Exception Tables Programming (Cont'd)

Allow Table Programming (Cont'd)

<u>Programming Steps</u>	<u>Description</u>
<p>2. For an entry that is to reference the Home Area Code table (special table 4) the entry may also be entered to expect or not expect a leading digit [1]. In fact in some cases it may be desirable to enter both of the following entries; Leading digit [1] - BB 1 DDD {S} and/or Non Leading [1] - BB DDD {S}</p>	

Where:

BB = Bin number (recommended bin 20)

DDD = "Don't Care" digit (three entries, DND button)

{S}= Search Special Table Command (TRANS button)

NOTE: If both leading digit [1] and non-leading digit [1] entries are made to reference the same table it is necessary to place the leading digit [1] entry ahead of the non-leading digit [1] entry in the allow table.

C. Deny Table Programming

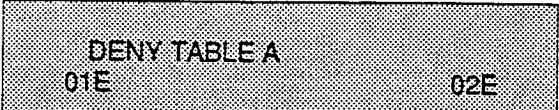
<u>Programming Steps</u>	<u>Description</u>
<p>1. Press the DEN-A or DEN-B flexible button (Button #2 or #4). The following display will be shown on the display phone:</p>	
	<p>Deny Table - Each Deny table contains ten (10) bin numbers. Each bin number may be up to eight (8) digits in length including {Don't Care} digits. Entries in the deny table represent numbers or codes that are to be denied or restricted. Common entries would be [1] for restricting all [1+] type of calls. Exceptions to this restriction would be entered into the allow table.</p>

The first two bin locations are displayed.

2. Dial on the dial pad the two-digit bin number (01-10) the deny code is to be entered into.
3. Dial the deny code where:
0 to 9, *, # = corresponding deny digits (numbers)
DND = Don't Care digit
4. Press HOLD button after each entry.
5. When all entries for one table are complete, press the flexible button for the next table.

- Deny table A is referenced and searched only after the allow table A is checked when Station COS is 2 and CO line COS is either 1 or 2.
- Deny table B is referenced and searched only after the allow table B is checked when Station COS is 3 and CO line COS is either 1 or 3.
- When station COS is 4 and CO line COS is 1 both allow tables are looked at first (allow table A first then allow table B) then both deny tables (deny table A first then deny table B).

Don't Care digits specify that the system should consider any digit dialed in that position as a match. Don't Care digits can not be entered as the last digit in an entry.

Search Special table commands can not be entered into the Deny tables.

To erase a bin, enter the two-digit bin number followed by pressing the HOLD button.

Exception Tables Programming (Cont'd)

D. Special Table Programming

Programming Steps

To program a special table it is first necessary to assign an area code to the table (except for the home area code).

1. To assign an area code to a special table press the appropriate AREA X flexible button (button #9-11). The following display will be shown on the display phone:

SPECIAL TABLE 1 AC

2. Enter the three (3) digit area code.
3. Press the HOLD button. The display will now update.
4. To enter office codes into the special table press the ST-X flexible button (button #5 - #8) that corresponds to the area code programmed above. The following display will be shown on the display phone:

SPECIAL TABLE 1 AC XXX

Where:

XXX= Area Code

5. Enter the three (3) digit office codes that are to be allowed followed by a [1] which means to allow this code. To remove a code from the allow list enter the three (3) digit office code followed by a [0] which will remove the code from the allow list.

XXX [1] = Allow code

XXX [0] = Remove code from the list

Where XXX = an office code from 200 to 999.

6. Press enter after every code entered. Multiple codes may be entered in a row. The display will update showing the first six codes in ascending order.

Description

The special tables provide greater flexibility in designing a toll plan for a particular site. Each special table allows entry of up to 800 three digit office codes (200 - 999). Three of these tables must be assigned an area code by which they are referenced. the fourth table is reserved for the home area code and requires no area code entry.

The special tables are referenced through entries in the allow tables. Four area codes, including the home area code, can be referenced to these special tables for further definition. When a special table is referenced, entries must be made in the special table specifying what office codes will be allowed. By default no codes are on the allow list.

Codes can be added to the allow list or removed from the list. When a special table is checked for a match, to a three digit code, but not found the system will then continue to search the next allow deny table that is to be checked. The system does not return to the allow table which routed the call to the special table.

Exception Tables Programming (Cont'd)

E. Displaying Toll Table Entries

Programming Steps

Description

To display entries in either the Allow /Deny tables or the special tables press the DISP flexible button (button #12) while entering information into a table.

It is possible to view entries into the toll tables using the display on the Executive telephone. To view all entries, the DISP flexible button (Button #12) is pressed multiple times to scroll through the entries.

1. While viewing entries made into an allow or deny table two (2) entries at a time will be displayed on the bottom line of the display. By pressing the DISP button again the next higher bins will be displayed. When the last entries are displayed pressing the DISP button again will show the first two entries.

NOTE: It is recommended to view all entries in the Allow and Deny table before leaving programming. Entries can be entered near the bottom of the list either for searching the special tables or entries that may have been made in error. Viewing the entire allow table will ensure proper entry and operation.

```
ALLOW TABLE A
01 XXXXXXXXE 02 XXXXXXXXX
```

Where:

X= Allow or Deny Code

E= End of Entry

While viewing entries into a special table six (6) three digit codes, that have been allowed, will be displayed in ascending order starting with the lowest entry. By pressing the DISP button again the next six (6) entries will be displayed. This will continue until all codes have been displayed.

```
SPECIAL TABLE 1 AC XXX
YYY YYY YYY YYY YYY YYY
```

Where:

XXX= Area Code

YYY= Allowed Office Code

SECTION 650

LEAST COST ROUTING PROGRAMMING

A. Introduction

Least Cost Routing (LCR) selects the most economical programmed route for an outgoing call. When a station user dials an outside number, the LCR feature analyzes the number and then automatically chooses an outside line from the group that has been programmed as most economical. The LCR feature puts the responsibility of choosing the least expensive route for each area code and exchange code on the system administrator, not on the station user. In order to make a routing decision, the LCR feature is programmed in the system database. The successful operation of this feature is completely dependent on the accuracy of the programming.

There are eight (8) different tables which are set up to monitor the dialing of digits and to select the best route for the call depending on time of day and day of week.

These tables are:

- Three (3) Digit Area/Office Code Table
- Six (6) Digit Office Code Table
- Exception Table
- Route List Table
- Insert/Delete Table
- Daily Start Time Table
- Weekday (Weekly) Schedule
- Toll Information Table

B. LCR Operation

The system first checks to see if the number dialed is more than two digits. If it is two digits or less, the call is processed according to instructions in the Exception Table. If the number is not found in the Exception Table, the call is denied.

If the number is more than two digits, it goes to the 3 Digit Table. If the first digit dialed is a "1" the leading 1 table will be checked with the following three digits. If the first digit dialed is not a "1" then the first three digits are checked against the Non-Leading 1 three digit table. The first three digits (either office code or area code) are then checked to see if they are in the 3 Digit Table. If they are not found there, the call is denied. If the digits are found in the 3 Digit Table, the system then checks for an entry to see if the 6 Digit Table must be referenced.

If the 6 Digit column is marked [yes] in the three digit table entry, the number is then checked in the 6 Digit Table.

There are twenty (20) six digit tables. Each six digit table is programmed and becomes associated to a specific area code with a selected route. Office codes are entered into the six (6) digit table that will be routed to a specific route list table. This allows the system administrator to split area codes for routing to different lines connected to the system. This helps when Foreign Exchange lines (FX Lines), Banded WATS lines, or "Dedicated" Lines (OPX's from another system) are in use.

If the office code is not found in the 6 Digit Table, the call is referred back to the 3 Digit Table for selecting a route list table. And then goes through the same procedures as described below.

Before actually selecting a route list table, the number is checked against the toll restriction tables (station COS). When LCR is enabled, only station Class of Service is referenced. CO line Class of Service is no longer applicable. All CO lines are considered Class of Service 1.

If the call is not allowed through the toll restriction tables, the call is denied. If it is allowed, the call then goes to the Route List Table as specified by either the three (3) digit or six (6) digit table.

The Time of day and Day of week is determined and the call is presented to the corresponding time period route within the specified route table. Each of the sixteen (16) Route Tables contain four time sensitive routes. Routes are determined by the time of day and day of week as specified in the Daily Start Time table and the Weekly Schedule table.

After the appropriate route is selected, LCR Class of Service becomes applicable. A station can use only those line groups programmed with a priority number equal to or higher than the station's LCR Class of Service.

If a line is not available in the first choice line group, the system advances to the next choice line group and searches for a free line. This process continues until an available line is found, or the last available line group is searched, or until a line group is reached with a priority assignment lower than the station's LCR Class of Service assignment.

When a line is available the system will seize that line and wait for dial tone. Then before dialing, the system checks the Insert/Delete table for digits that should be deleted from the front of the number or

digits that should be inserted either before or after the number dialed. Finally the system begins to dial the number out over the selected line. All of this analyzing and manipulation of the number takes only a fraction of a second from the time the station user begins to dial until the number is dialed out over the public network lines.

If no lines are available in any of the CO line groups programmed for that route and allowed to that station, the call can be automatically queued on to the first choice (least costly) line group. If the user waits three seconds after dialing the number, they will hear confirmation tone which indicates that an automatic LCR Queue Callback has been activated on the first choice line group. When a CO line becomes available in the first choice line group the system will ring the calling station. When answered by the station the system will automatically seize the line and redial the number.

C. LCR Programming

Programming Steps

If you are in the program mode, continue using the program codes. If you are starting to program here, enter the program mode first.

NOTE: LCR must be disabled while programming or making changes to any of the LCR tables. Refer to sec. 610.23 for instructions to disable LCR.

1. To program the system for Least Cost Routing, press FLASH and dial [61]. The following message is shown on the display phone:

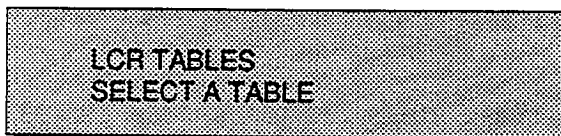

2. There are eight tables which can be programmed here for LCR (you must also program LCR Class of Service in Station Programming). Use the procedures listed below to program these LCR tables:

NOTE: It is extremely important that the worksheets be completed before programming the LCR tables.

Description

The Least Cost Routing (LCR) feature allows for the automatic selection of the most economical trunk according to the number dialed and the time of day and day of the week. There are eight different tables which are set up to monitor the dialing of digits of a station and to select the best route programmed for the call. These tables are:

- Three (3) Digit Area/Office Code Table
- Six (6) Digit Office Code Table
- Exception Table
- Route List Table
- Insert/Delete Table
- Daily Start Time Table
- Weekday (Weekly) Schedule
- Toll Information Table

When programming LCR the flexible buttons are mapped as follows:

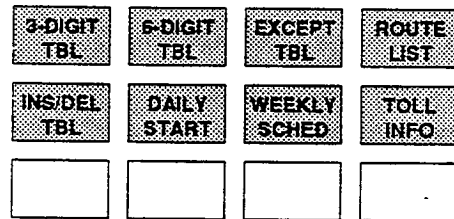

Default: The three digit tables contain a default where all Long distance (numbers requiring an area code) with a leading digit "1" are routed to Route List Table 00. Route List Table 00 will route calls on lines in group 1 for all time periods. All Local calls (numbers that are dialed without an area code) with or without a leading digit "1" are routed to route list table 01. Route table 01 also routes calls using lines in line group 1 for all time periods. Refer to Figure 660-6 for a complete listing of the LCR default data.

Related Programming: LCR Enable/Disable sec. 610.23. Station Class of service and station LCR Class of service in section 630.

LCR PROGRAMMING (Cont'd)

D. 3-Digit Area/Office Code Table

Programming Steps

1. Press 3-DIGIT TBL flexible button (Button # 1). The following message will be shown on the display phone:

3 DIGIT ROUTING TABLE
ENTER L NNN RR6 PP HOLD

Where:

L = [0] for non leading 1 ("1" not dialed)
[1] for leading 1 ("1" is dialed)

NNN = area/office code

RR = route list number 00-15

6 = [0] do not go to 6 digit table
[1] go to 6 digit table

PP = number of digits expected to be dialed.

2. Press the HOLD button to enter the data. Display will now update.

Description

3 Digit Area/Office Code Table. This table is divided into two sections - Leading 1 (a [1] is dialed before the number) and Non Leading 1 (no [1] is dialed before the number). This gives the system the ability to handle call routing in areas that require a [1] before a long distance number, as well as in areas that do not require the [1].

Both of these tables include all area codes (NPA's), and office codes (NXX's), from 000 to 999, including such numbers as 911, 411, etc. A complete entry into these tables include a route list table to be used, if the 6 Digit Table is to be checked and the number of digits likely to be dialed (example 7 digits or 10 digits).

All local office codes must be entered in this table even if they do not require long distance calling.

The number of digits to expect entry will aid the system in identifying when the last digit is dialed and to begin routing the call. This also helps to free SLT DTMF receivers if SLT traffic in the system is heavy.

E. 6-Digit Office Code Table

Programming Steps

1. Press the 6-DIGIT TBL flexible button (Button # 2). The following message is then shown on the display phone:

6 DIGIT ROUTING TABLE
ENTER S AAA RR NNN HOLD

Where:

S = [0] to remove codes
[1] to add codes

AAA = area code

RR = route number 00-15

NNN = office code

2. Press HOLD after each office code entry.
3. Enter additional office codes to be programmed into the same Area Code/ Route Table, pressing hold after each office code entry.
4. Press a flexible button to program a different table.

To delete all entries in an Area Code / Route table, enter 0 AAA RR ###.

Description

6 Digit Office Code Table. This table is used to determine a route from one or a group of individual office codes within an area code. Certain office codes within an area code can be given unique or special routing. If the office code dialed is not found in the 6 Digit Office Code Table, the call is then routed according to the route list table as was entered in the 3 Digit Table.

The system allows for twenty (20) six (6) digit Area/Office code tables that may be used to route specific office codes within an area code. Each table will route calls for a common area code to a specified route. All entries made into a table will route those office codes to the specified route list table. An area code may be entered into more than one six (6) digit table with different routes specified.

LCR PROGRAMMING (Cont'd)

F. Exception Code Table

Programming Steps

1. Press EXCEPT TBL flexible button (Button #3). The following message will be shown on the display phone:

EXCEPTION CODE TABLE
ENTER S XX RR HOLD

Description

Exception Table. This table is used for operator calls and any other calls which would use a one- or two-digit entry rather than a three-digit area code.

Where:

- S = [0] to remove code from table
 - [1] to add code to table
 - XX= exception codes
 - (for single digit codes, press DND button (flexible button 21) as 2nd digit).
 - The digits [*] and [#] may be entered as valid digits.
 - RR= route table number, 00-15
2. HOLD must be pressed after each entry. Display will now update.
 3. Press program button 3 again for further entries. Up to 20 Exception codes may be programmed in this table.

LCR PROGRAMMING (Cont'd)

G. Route List Table

Programming Steps

1. Press the ROUTE LIST flexible button (Button #4). The following message will be shown on the display phone:

ROUTE LIST TABLE
ENTER RR T G DD L HOLD

Where:

- RR = Route List Table number 00-15
 - T = Time Period Route list 1-4
 - G = CO Line Group 1-7
 - DD = Insert/Delete Table reference 00-19
(## for none)
 - L = LCR Class of Service (LCOS)
2. Press HOLD. Display will now update.
 3. To enter additional CO line groups in the same time period route list number:
Press G DD L HOLD
 4. To enter data for a different list within a route, press program button 4 and enter all data (RR T G DD L).
 5. Repeat above to program a new Route Number 00 to 15 or press a flexible button to program other LCD data.

Description

Route List Table. Up to sixteen different routes list tables can be programmed. Each route list table contains four time period routing lists, one for each of the available (four) daily start time periods. Within each time period route list up to seven CO (outside) line groups and their corresponding Insert/Delete Table if any and LCR class of service priority are programmed on a per line group basis.

When routing a CO call through LCR, CO Line groups are accessed in sequence so that the first line group entered represents the least costly (and first selected) and the last line group entered represents the most costly (and last selected).

The Route List Table references many other tables when processing a call for routing. First of all, the Daily start time table is referenced to determine what start time entry should be checked in the weekly schedule table. The corresponding entry in the weekly schedule table depending on the day of the week then determines which Time Period Route list should be used within the Route List Table.

The system then begins to check for idle lines in the first entered CO line group and will proceed until an idle line is found. While it is searching for an idle CO line the Station LCR COS is checked against the entries for LCR COS Priority of the specific CO line groups (see LCR COS Priority explanation below). Once an idle CO line is found with a LCR priority equal to or higher than the station's LCR COS then a final check is made to determine if an Insert/Delete table should be referenced. Once all of the tables and entries are checked the system then processes the call on the outside CO line.

NOTE: Make sure you have made entries into all Time Period Route List that are referenced in the weekly schedule table.

LCR COS Priority. A station should be assigned a class of service for LCR (refer to station programming sec. 630). The LCR COS can be between 0 and 6, with 0 being unrestricted and 6 being the most restrictive. Within the time period route List Table, line groups are given an LCR COS Priority assignment between 0 and 6. A station using LCR will be able to use only those CO (outside) line groups with a priority assignment of equal or higher value than the station's LCR Class of Service (i.e. a station with LCOS 3 can use line groups with a priority of 3-6).

Table 650-1 LCR Class of Service Table

Allowed access to Route	LCR CO Line Group Priority							
	0	1	2	3	4	5	6	
STATION LCR COS	0	Y	Y	Y	Y	Y	Y	Y
	1	N	Y	Y	Y	Y	Y	Y
	2	N	N	Y	Y	Y	Y	Y
	3	N	N	N	Y	Y	Y	Y
	4	N	N	N	N	Y	Y	Y
	5	N	N	N	N	N	Y	Y
	6	N	N	N	N	N	N	Y

N= Cannot use Line Group
Y= Has access to Line Group

LCR PROGRAMMING (Cont'd)

H. Insert/Delete Table

Programming Steps

1. Press INS/DEL TBL flexible button (button #5). The following message will be shown on the display phone:

DIGIT INSERT/DELETE
ENTER TT X DDD HOLD

2. Enter the table information as follows;
Where:

TT = Insert/Delete Table Number 00-19

X = [0] Pre-Delete numbers
(first digits dialed in the number)
[1] Pre-Insert numbers
(insert digits in front of number dialed)
[2] Post-Insert numbers
(insert digits behind number dialed)

DDD = digits (up to 16 digits may be deleted from the beginning of the number dialed and up to 40 digits can be inserted (20 pre and 20 post)).

3. Press HOLD after programming each table.
Display will now update.

To add and delete numbers in the same table, enter the different insertion / deletion tables in step 2 and enter as separate entries using the same table number.

In the Insert Tables for LCR programming, press the TRANS button for a pause. Also both the [*] and [#] digits are allowed as valid digits for inserting digits dialed over the network. The [*] and [#] are valid entries for adding digits in both the pre (in front of) or post (behind the number) tables.

The [*] and [#] can not be used as delete characters in the Delete Tables.

Description

Insert/Delete Table. Digits can be either added or deleted when dialing a number. For instance, if a user dials a long distance call that should be placed on a foreign exchange (FX) line, the digit [1] and the three digit area code (NPA) dialed by the user must be deleted before the call can be placed on that FX line. An Insert/Delete Table can be programmed to do this. Digits can also be added to a number that has been dialed by the user. For instance, Other Common Carrier (OCC) access codes and authorization (ID) codes can be automatically inserted by the system either in front of and/or behind the number dialed.

There are twenty Insert/Delete Tables and each table allows for entries into a delete table and a pre and post insert table. Up to forty (40) digits (including pauses) can be inserted (twenty (20) pre and twenty (20) post) and up to sixteen digits can be deleted. Digits can be inserted before or after the number dialed but can be deleted only from the start of the number dialed.

LCR PROGRAMMING (Cont'd)

I. Daily Start Time Table

Programming Steps

1. Press the DAILY START flexible button (button #6). The following message will be shown on the display phone:

DAILY START TIME TABLE
HHMM HHMM HHMM HHMM HOLD

2. Enter times in military form (2400 Hours) in succession. Pressing the HOLD button after each time entered. Default times are 0800, 1700, 2300 (8 AM, 5 PM, and 11 PM), and the fourth time is disabled (####). To change a start time all times must be re-entered.
3. Display will now update. #### will display if nothing is entered for a specific time.

Description

Daily Start Time Table. The daily start time table is used to correlate the LCR routing table to the time sensitive discount structure offered by the customers carrier. For example in the most common situation the most expensive rate period is between 8:00 am and 5:00 pm, often called the daily rate. The first discount period usually starts at 5:00 pm and runs until 11:00 pm, often called Evening Rates. The remaining time (from 11:00 pm until 8:00 am) in this example is referred to as night time rates which usually has the biggest discount. With the wide selection of Common Carriers the least costly route for a particular area code may be different at different times of the day. To accommodate this situation, this table and the Weekly Schedule Table work together, dividing the day into four possible time periods.

The entries in the Daily Start Time table are used to select the time period to reference in the weekly schedule. Based on the time a call is placed the daily start time table selects the time period to choose in the weekly schedule. The weekly schedule is then used to determine the time period route list in the Route List Table to use for routing the call for a particular day of the week.

The times are entered in the 24 hour format.

Default: By default these tables are set at the standard divisions of 8AM, 5PM, and 11PM. However, these times can be changed.

Table 650-2 Daily Start Time & Weekly Schedule Tables

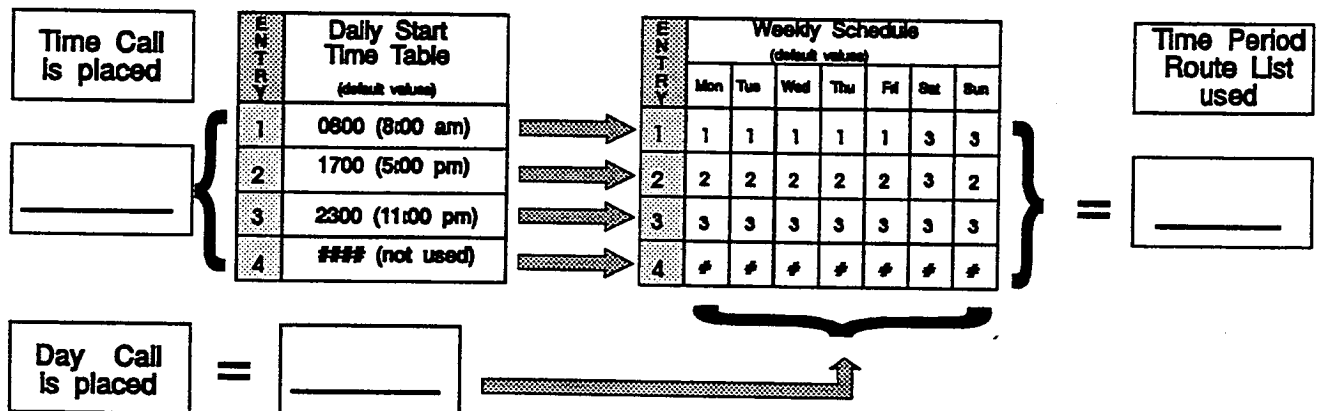

LCR PROGRAMMING (Cont'd)

J. Weekly Schedule Table

Programming Steps

1. Press the WEEKLY SCHED flexible button (button #7). The following message will be shown on the display phone:

WEEKLY SCHEDULE TABLE
ENTER D TTTT HOLD

Description

Weekly Schedule Table. The weekly schedule table determines what Time Period Route list to use within the Route List Table. When a call is placed and ultimately sent to a route list (call is not denied) based on the time of day the call is placed the Daily Start Time Table (see description above) selects the time period to reference in the weekly schedule table. The time period route entered for the specified time period, as determined in the daily start time table and based on the day of week, is then selected and the call will be routed according to the specified time period route list.

For example: if a call is placed at 5:45 pm on a Monday then according to the daily start time table (using default values) the entry for time period two of the weekly schedule is checked. Because it is Monday the entry for time period two on Monday is used and the result is that the Time Period Route List number two (again using default values) will be used for all routes. Thus the call is routed according to the entries in Time Period Two (2) route list no matter what route (00-15) is selected. Refer to Table below

Where:

- 0= Monday
- 1= Tuesday
- 2= Wednesday
- 3= Thursday
- 4= Friday
- 5= Saturday
- 6= Sunday

T = Time Period Route List (1-4) to use for the time of day (based on the daily start time table). Enter values for all time periods specified in the daily start time table for that day.

1st T = Time Period Route list for the FIRST Daily Start Time.
(applies to all Route List Tables)

2nd T = Time Period Route List for the SECOND Daily Start Time.
(applies to all Route List Tables)

3rd T = Time Period Route List for the THIRD Daily Start Time.
(applies to all Route List Tables)

4th T = Time Period Route List for the FOURTH Daily Start Time.
(applies to all Route List Tables)

2. Press HOLD button after each complete daily entry. Display will now update.

Table 650-3 Examples: Daily & Wkly Start Time Tables

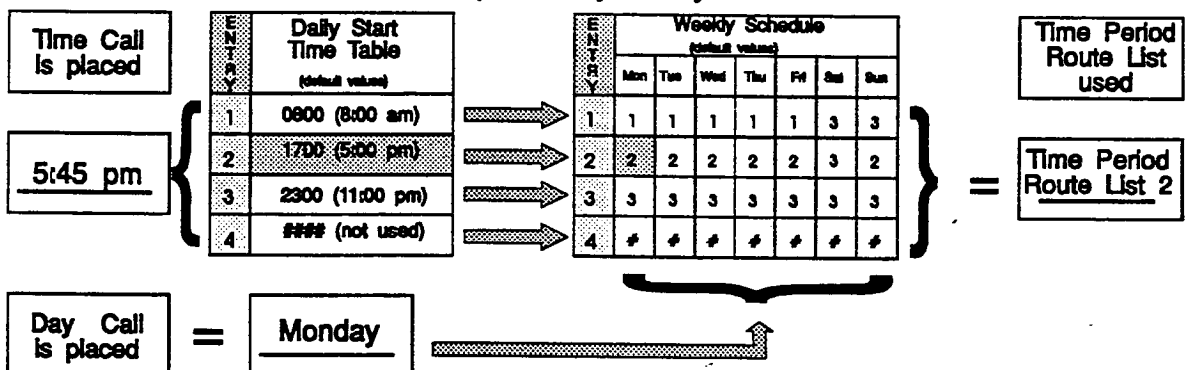

LCR PROGRAMMING (Cont'd)

K. LCR Routing for Toll Information

Programming Steps

1. Press TOLL INFO flexible button (button #8)
The following message will be shown on the display phone:

LCR ROUTE FOR 555-1212
ENTER ROUTE

2. Enter 2-digit Route List number (00-15) for the Route to be referenced in the Route List Table.
 3. Press HOLD after programming the Route number. Display will now update.
- Enable LCR at this point. Refer to System programming.

Description

Toll Information routing adds provisions to the LCR call processing which will allow common call routing for all toll information calls. Both 1-(XXX)555-1212 and (XXX)-555-1212 calls will be intercepted and sent to a selected "Route List" in the "Route List Table". The number dialed will be "looked at" before reaching the "Three Digit Table" and if it is determined to be a toll information call, preceded with an area code with or without a leading digit 1, the call will be sent to the "Route List" assigned in programmed for the LCR feature.

Default programming for Toll Information Calls will be to Route List Table zero (0) which will allow toll information calls to be placed on the system at default.

A Toll Information route will be chosen over a 3-digit or 6-digit route assignment if both are assigned.

Entering ## will deny all Toll Information calls.

NOTE: Local information calls (555-1212 or 1-555-1212) must be programmed separately within the 3-Digit Area/Office Code Table.

L. Default LCR Data Base

In an effort to decrease installation and set up time, usually associated with LCR, a default LCR data base has been incorporated. The default LCR data base will provide basic routing for local and long distance dialing. Default entries have been made in the Three Digit Table for local office codes (NNX's) and all area codes (NPA's). Two routes have been established with the default data base for routing of all calls under default. The entire default data base is shown in Table 6-10.

The three digit tables contain a default where all Long distance (numbers requiring an area code) with a leading digit "1" are routed to Route table 00. Route Table 00 will route calls on lines in group 1 for all time periods. All Local calls (numbers that are dialed without an area code) with or without a leading digit "1" are routed to route list table 01. Route list table 01 also routes calls using lines in line group 1 for all time periods.

SECTION 660

SYSTEM DATA BASE PRINTOUTS

660.1 PRINT ENTIRE SYSTEM DATA BASE

Programming Steps

If the system is in the programming mode, continue using program codes. If starting to program here enter the programming mode first (refer to paragraph 600.3).

If a complete printout of the entire data base is desired:

1. Press FLASH and dial [80]. The following message will be shown on the display of a display phone:

PRINT SYSTEM DATA
PRESS HOLD

2. To print the entire data base, press the HOLD button. The display will update to indicate what portion of the data base is being printed.

PRINTING SYS PARAM
PRINTING CO LINES
PRINTING STATIONS
PRINTING EX TABLES
PRINTING SYS SPEED NO
PRINTING LCR TABLES

When the system has finished sending the entire data base to the printer, confirmation tone will be heard.

Description

With a printer connected to the RS-232C port, of the CPB, the currently stored customer data base can be printed or "uploaded" into a file. This command allows the entire data base to be "dumped" as a permanent record which can serve as a hard copy of the data base.

The system Baud rate must match that of the printer or receiving device. Refer to section 610.20 for instructions on viewing or changing the baud rate in the 96EX system.

Printing the entire data base takes a while to print. The data base is printed in the following order:

- All System Parameters
- All CO Line programming (CO Lines 01-40)
- All Station attributes (Stations 100-195)
- Toll Tables (allow, deny and special tables)
- System Speed Dial Numbers (bins 20-99)
- LCR Tables

Refer to the following Figures for examples of the data base printouts. Also refer to the following paragraphs for instructions on printing only portions of the data base.

System Data Base Printouts (Cont'd)

660.2 SYSTEM PARAMETERS

Programming Steps

If the system is in the programming mode, continue using program codes. If starting to program here enter the programming mode first (refer to paragraph 600.3).

If a printout of all System Parameters is desired:

1. Press FLASH and dial [81]. The following message will be shown on the display of a display phone:

PRINT SYS PARAM
PRESS HOLD

2. To print the system parameter data base, press the HOLD button. The display will update.

PRINTING SYS PARAM

When the system has finished sending the information to the printer confirmation tone will be heard.

Description

With a printer connected to the RS-232C port, of the CPB, the currently stored customer data base can be printed or "uploaded" into a file. This command allows the System Parameters data base to be "dumped" as a permanent record which can serve as a hard copy.

The system Baud rate must match that of the printer or receiving device. Refer to section 610.20 for instructions on viewing or changing the baud rate in the 96EX system.

When printing the System Parameters the following data is printed;

- All System Timers
- All System wide options (i.e. external night ringing, Hold preference etc...)
- Attendant programming
- Other system assignments (i.e. Loud bell, Executive/Secretary, SMDR etc...)
- UCD group and associated programming
- Voice Mail Group and associated programming
- Hunt Group programming
- Weekly Night Mode schedule

Refer to the following Figure for an example of the system parameters data base print out.

Data Base Printout	Description
7S MONITOR Eng. Ver. X.XY DATE: 06/13/90 TIME: 11:09:40 ENTER PASSWORD: adm> ENTER PROGRAM NO adm>81 PRINT SYS PARAM PRESS HOLD adm> <u>SYSTEM PARAMETERS</u> Eng. Ver. 2.0d	
SHR EHR XFR PFT PT CPT CFN 60 180 45 10 2 180 15	SHR= System Hold Recall Timer EHR= Exclusive Hold Recall Timer XFR= Transfer Recall Timer PFT= Preset Forward Timer PT= Pause Timer CPT= Call Park Timer CFN= Call Forward No-Answer Timer CFT= Conference Timer MWT= Message Wait Reminder Tone PTO= Page Timeout Timer COT= CO Ring Detect Timer ART= Attendant Recall Timer ICM= Phone Box Timer SRT= Single Line Receiver Timer HFT= Hook Flash Timer HFD= Hookswitch Bounce Timer DAC= DISA Access Code HPR= Hold Preference ENR= External Night Ringing AOR= Attendant Override INT= Dedicated Attendant Intercom BGM= Background Music LCR= LCR Enable/Disable PWT= Page Warning Tone
CFT MWT PTO COT ART ICM SRT 10 0 15 3 1 20 20	
HFT HFD DAC HPR ENR 10 10 100 SYS N	
AOR INT BGM LCR PWT N Y Y N Y	
ATTENDANT STATIONS 100 ### ##	
LOUD BELL ASSIGNMENTS #### ##	
PBX DIALING CODES ## ## ## ## ##	
EXECUTIVE/SECRETARY PAIRINGS 1 = ### ## 2 = ### ## 3 = ### ## 4 = ### ##	
UCD ALT OVR ANO STN# 890 891 892 893 894 895 896 897	UCD= Uniform Call Distribution ALT= UCD Alternate UCD Group OVR= UCD Overflow Station ANO= Announcement Tables Index STN#= UCD Station Numbers
UCD TIMERS RING MIT OVER WRAP 60 60 60 4	RING= UCD Ring Timer MIT= UCD Message Interval Timer OVER= UCD Overflow Timer WRAP= UCD Auto Wrap-Up Timer
ANNOUNCEMENT TABLE TYPE INDEX TIME # ### ## # ### ##	

Figure 660-1 DB Printout of System Parameters

Data Base Printout	Description
SMDR TYPE PRNT BAUD ACCT N LD 80 4800 N	
DIAL PULSE RATIO SPEED 6040 10PPS	
VM ALT LEV RET STN# 690 # # 691 # # 692 # # 693 # # 694 # # 695 # # 696 # # 697 # #	VM= Voice Mail Group ALT= Alternate Voice Mail Groups LEV= "Leave" Outpulsing Table Index RET= "Retrieve" Outpulsing Table Index STN#= VM Station numbers
VOICE MAIL OUT TABLE IDX PREFIX SUFFIX 0 1 2 3 4 5 6 7	
VOICE MAIL CO DISCONNECT SIGNAL	
HUNT GROUPS HG0..590 PILOT HUNT HG1..591 PILOT HUNT HG2..592 PILOT HUNT HG3..593 PILOT HUNT HG4..594 PILOT HUNT HG5..595 PILOT HUNT HG6..596 PILOT HUNT HG7..597 PILOT HUNT	
AUTO NIGHT MODE N	
<u>WEEKLY NIGHT MODE SCHEDULE</u>	
DAY END START TIME TIME	
M 0 0800 1700 T 1 0800 1700 W 2 0800 1700 T 3 0800 1700 F 4 0800 1700 S 5 ##### S 6 #####	
EXECUTIVE OVERRIDE WARNING TONE Y adm>m exiting admin...	

Figure 660-1 DB Printout of System Parameters (Con't)

System Data Base Printouts (Cont'd)

660.3 CO LINE ATTRIBUTES

Programming Steps

If the system is in the programming mode, continue using program codes. If starting to program here enter the programming mode first (refer to paragraph 600.3).

If a printout of the CO Line Attributes is desired:

1. Press FLASH and dial [82]. The following message will be shown on the display of a display phone:

PRINTING CO LINES
ENTER RANGE PRESS HOLD

2. Enter a four (4) digit number for the range of lines a printout is desired. To print a single CO Line enter that line number twice (i.e. 0101). To print out data for all CO Lines enter [0140]. the following display will be shown on the display phone;

PRINTING CO LINES

When the system has finished sending the requested information to the printer, confirmation tone will be heard.

Description

With a printer connected to the RS-232C port, of the CPB, the currently stored customer data base can be printed or "uploaded" into a file. This command allows either a range of CO Lines or the entire CO Line data base to be "dumped" as a permanent record which can serve as a hard copy of the CO Line attribute data base.

The system Baud rate must match that of the printer or receiving device. Refer to section 610.20 for instructions on viewing or changing the baud rate in the 96EX system.

When printing the CO Line attributes the following data is printed;

- All CO Line parameters
- CO Line ringing assignments

Refer to the following Figure for an example of the CO Line attribute data base print out.

Data Base Printout	Description
<pre> 7S MONITOR Eng. Ver. X.XY DATE: 06/13/90 TIME: 11:10:56 ENTER PASSWORD: adm> ENTER PROGRAM NO adm>82 PRINT CO LINES ENTER RANGE PRESS HOLD adm>0140 <u>CO LINE ATTRIBUTES</u> <u>CO 1</u> </pre>	<pre> SIGNAL= DTMF/Dial Pulse TYPE= CO/PBX UNA= Universal Night Answer SUPV= Loop Supervision DISA= Direct Inward System Access FLTM= Flash Timer GRP= CO Line Group COS= CO Line Class of Service CONF= CO Line Conference PRI= CO Line Privacy </pre>
<pre> SIGNAL TYPE UNA SUPV DTMF CO Y N DISA FLTM GRP COS N 10 1 1 CONF PRI Y Y </pre>	
<pre> RING ASSIGNMENTS 100B </pre>	
<pre> <u>CO 2</u> SIGNAL TYPE UNA SUPV DTMF CO Y N DISA FLTM GRP COS N 10 1 1 CONF PRI Y Y </pre>	
<pre> RING ASSIGNMENTS 100B </pre>	
<pre> <u>CO 3</u> SIGNAL TYPE UNA SUPV DTMF CO Y N DISA FLTM GRP COS N 10 1 1 CONF PRI Y Y </pre>	
<pre> RING ASSIGNMENTS 100B </pre>	
<pre> <u>CO 4</u> SIGNAL TYPE UNA SUPV DTMF CO Y N DISA FLTM GRP COS N 10 1 1 CONF PRI Y Y </pre>	
<pre> RING ASSIGNMENTS 100B </pre>	
<pre> adm>m exiting admin... </pre>	

Figure 660-2 DB Printout of CO Line Attributes

System Data Base Printouts (Cont'd)

660.4 STATION ATTRIBUTES

Programming Steps

If the system is in the programming mode, continue using program codes. If starting to program here enter the programming mode first (refer to paragraph 600.3).

If a printout of the Station Attributes is desired:

1. Press FLASH and dial [83]. The following message will be shown on the display of a display phone:

PRINT STATIONS
ENTER RANGE PRESS HOLD

2. Enter a six (6) digit number for the range of stations a printout is desired. To print a single stations data enter that station extension number twice (i.e. 100100). To print out data for all stations enter [100195]. the following display will be shown on the display phone:

PRINTING STATIONS

When the system has finished sending the requested information to the printer, confirmation tone will be heard.

Description

With a printer connected to the RS-232C port, of the CPB, the currently stored customer data base can be printed or "uploaded" into a file. This command allows either a range of station data or all stations data information to be "dumped" as a permanent record which can serve as a hard copy of the station attribute data base.

The system Baud rate must match that of the printer or receiving device. Refer to section 610.20 for instructions on viewing or changing the baud rate in the 96EX system.

When printing the Station attributes the following data is printed;

- All current station parameters
- Current Flex Button assignments

Refer to the following Figure for an example of a Station attribute data base print out.

Data Base Printout	Description
<p>7S MONITOR Eng. Ver. X.XY DATE: 06/13/90 TIME: 11:12:51 ENTER PASSWORD: adm> ENTER PROGRAM NO</p>	
<p>adm>83 PRINT STATIONS ENTER RANGE PRESS HOLD adm>100195 STATION ATTRIBUTES</p>	
<p><u>STA 100</u> (KEYSETS)</p>	
<p>PAGE DND SPD QUE PLA Y Y Y Y N</p>	<p>PAGE= Paging Access DND= Do Not Disturb</p>
<p>LCOS LCR FWD SID AID SPK 0 N Y 0 0</p>	<p>SPD= System Speed Dial Access QUE= Line Queue Access</p>
<p>DCOS NCOS 1 1</p>	<p>PLA= Preferred Line Answer LCOS= LCR Class of Service</p>
<p>PICKUP 1 PAGE 1</p>	<p>LCR= Forced LCR FWD= Station Call Forward Access</p>
<p>PREFWD CO ACCESS 1</p>	<p>SID= Station ID AID= Associated ID (DSS/DLS Console)</p>
<p>BUTTONS 01D100 02D101 03D102 04D103 05D104 06D105 07D106 08D107 09D01 1002 1103 1204 1305 1406 15PL1 16LP 17CBK 18PKU 19MUT 20LQU 21DND 22CPO</p>	<p>SPK= Speakerphone Option DCOS= Day Class of Service NCOS= Night Class of Service PICKUP= Pickup Groups PAGE= Paging Groups</p>
<p>PRIME KEY 0 Y</p>	<p>PREFWD= Preset Forward Assignment BUTTONS= Refer to Table 630-1</p>
<p>CONF PRI EXECUTIVE Y Y N</p>	<p>CONF= Conference PRI= Privacy</p>
<p><u>STA 193</u> (SINGLE LINE SETS)</p>	
<p>PAGE DND SPD QUE PLA Y Y Y Y N</p>	
<p>LCOS LCR FWD SID AID SPK 0 N Y 5 0</p>	
<p>DCOS NCOS 1 1</p>	
<p>PICKUP 1 PAGE 1</p>	
<p>PREFWD CO ACCESS 1</p>	
<p>BUTTONS 00PL7</p>	
<p>PRIME KEY 1 N</p>	
<p>CONF PRI EXECUTIVE Y Y N</p>	
<p>adm>m exiting admin...</p>	

Figure 660-3 DB Printout of Station Attributes

System Data Base Printouts (Cont'd)

660.5 EXCEPTION TABLES

Programming Steps

If the system is in the programming mode, continue using program codes. If starting to program here enter the programming mode first (refer to paragraph 600.3).

If a printout of the Exception tables are desired:

1. Press FLASH and dial [84]. The following message will be shown on the display of a display phone:

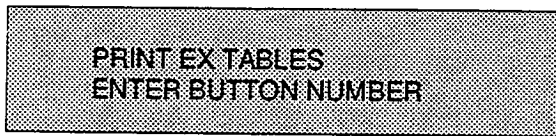

2. Press a flexible button to correspond to the exception table a print out is desired. Then press HOLD.

When the system has finished sending the requested information to the printer, confirmation tone will be heard.

Description

With a printer connected to the RS-232C port, of the CPB, the currently stored customer data base can be printed or "uploaded" into a file. This command allows each exception table to be printed individually to serve as a permanent record which can be saved as a hard copy of the exception table data base.

The system Baud rate must match that of the printer or receiving device. Refer to section 610.20 for instructions on viewing or changing the baud rate in the 96EX system.

When printing information from the exception tables the flex buttons are mapped as follows:

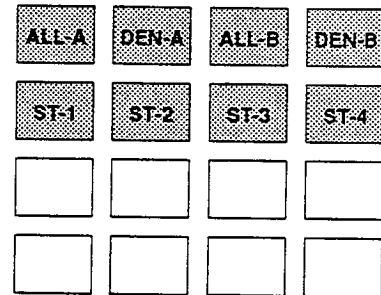

Refer to the following Figure for an example of the Exception Tables data base print out.

```

7S MONITOR Eng. Ver. X.XY
DATE: 06/13/90 TIME: 11:14:26
ENTER PASSWORD:
adm>,
    ENTER PROGRAM NO

adm>84
PRINT EX TABLES
ENTER BUTTON NUMBER
adm>1
adm>q
PRINT ALLOW TABLE A

PRESS HOLD
adm>
EXCEPTION TABLES

Allow Table A
-----
01          11
02          12
03          13
04          14
05          15
06          16
07          17
08          18
09          19
10          20

adm>w
PRINT DENY TABLE A

PRESS HOLD
adm>
EXCEPTION TABLES

Deny Table A
-----
01          06
02          07
03          08
04          09
05          10

adm>e
PRINT ALLOW TABLE B

PRESS HOLD
adm>
EXCEPTION TABLES

Allow Table B
-----
01          11
02          12
03          13
04          14
05          15
06          16
07          17
08          18
09          19
10          20

adm>r
PRINT DENY TABLE B

PRESS HOLD
adm>
EXCEPTION TABLES

Deny Table B
-----
01          06
02          07
03          08
04          09
05          10

adm>a
PRINT SPECIAL TABLE 1
PRESS HOLD
adm>
EXCEPTION TABLES

SPECIAL TABLE 1 AREA CODE
-----
ALLOWED OFFICE CODES

adm>s
PRINT SPECIAL TABLE 2
PRESS HOLD
adm>
EXCEPTION TABLES

SPECIAL TABLE 2 AREA CODE
-----
ALLOWED OFFICE CODES

adm>d
PRINT SPECIAL TABLE 3
PRESS HOLD
adm>
EXCEPTION TABLES

SPECIAL TABLE 3 AREA CODE
-----
ALLOWED OFFICE CODES

adm>f
PRINT SPECIAL TABLE 4
PRESS HOLD
adm>
EXCEPTION TABLES

SPECIAL TABLE 4 HOME AREA CODE
-----
ALLOWED OFFICE CODES

adm>m
exiting admin...
    
```

Figure 660-4 DB Printout of Exception Tables

System Data Base Printouts (Cont'd)

660.6 SYSTEM SPEED DIAL

Programming Steps

If the system is in the programming mode, continue using program codes. If starting to program here enter the programming mode first (refer to paragraph 600.3).

If a printout of the System speed dial entries are desired:

1. Press FLASH and dial [85]. The following message will be shown on the display of a display phone:



PRINT SYS SPEED NO
ENTER RANGE PRESS HOLD

2. Enter a four (4) digit number for the range of system speed dial bins a printout is desired. To print a single system speed dial bin enter that bin number twice (i.e. 2020). To print out all system speed dial bins enter [2099]. the following display will be shown on the display phone:



PRINTING SYS SPEED NO

When the system has finished sending the requested information to the printer, confirmation tone will be heard.

Description

With a printer connected to the RS-232C port, of the CPB, the currently stored customer data base can be printed or "uploaded" into a file. This command allows either a range of system speed dial bins or all bins can be "dumped" as a permanent record which can serve as a hard copy of the system speed dial data base.

The system Baud rate must match that of the printer or receiving device. Refer to section 610.20 for instructions on viewing or changing the baud rate in the 96EX system.

Refer to the following Figure for an example of a System Speed Dial data base print out.

```
7S MONITOR Eng. Ver. X.XY          50
DATE: 06/13/90 TIME: 11:15:46
ENTER PASSWORD:                    51
adm>,
  ENTER PROGRAM NO                  52

adm>85                              53
  PRINT SYS SPEED NO
  ENTER RANGE PRESS HOLD           54
adm>2083
SYSTEM SPEED NUMBERS              55
20 number from 1 to 24 digits      56
21                                  57
22                                  58
23                                  59
24                                  60
25                                  61
26                                  62
27                                  63
28                                  64
29                                  65
30                                  66
31                                  67
32                                  68
33                                  69
34                                  70
35                                  71
36                                  72
37                                  73
38                                  74
39                                  75
40                                  76
41                                  77
42                                  78
43                                  79
44                                  80
45                                  81
46                                  82
47                                  83
48
49                                  adm>m
                                  exiting admin...
```

Figure 660-5 DB Printout of System Speed Numbers

System Data Base Printouts (Cont'd)

660.7 LCR TABLES

Programming Steps

If the system is in the programming mode, continue using program codes. If starting to program here enter the programming mode first (refer to paragraph 600.3).

If a printout of the LCR tables are desired:

1. Press FLASH and dial [86]. The following message will be shown on the display of a display phone:

PRINT LCR TABLES
ENTER BUTTON NUMBER

2. Press a flexible button to correspond to the desired LCR table printout. Then follow the steps as outlined below.

When the system has finished sending the requested information to the printer, confirmation tone will be heard.

Description

With a printer connected to the RS-232C port, of the CPB, the currently stored customer data base can be printed or "uploaded" into a file. This command allows each LCR table to be printed individually to serve as a permanent record which can be saved as a hard copy of the LCR data base.

The system Baud rate must match that of the printer or receiving device. Refer to section 610.20 for instructions on viewing or changing the baud rate in the 96EX system.

When printing information from the LCR tables the flex buttons are mapped as follows:

3-DIGIT TBL	6-DIGIT TBL	EXCEPT TBL	ROUTE LIST
INS/DEL TBL	DAILY START	WEEKLY SCHED	TOLL INFO

A. 3-Digit Table

Programming Steps

To print the three (3) digit table:

1. Press the 3-DIG TBL flexible button (button #1). The following message will be shown on the display phone:

PRINT 3 DIGIT TABLE
ENTER RANGE, PRESS HOLD

2. Enter the range of 3 digit codes (000 - 999) that a print out is desired.
3. Press HOLD. If a print out of the entire 3 digit table is desired you may skip step 1 above and simply just press HOLD.

When all the requested data has been sent to the printer, confirmation tone will be heard.

Description

Refer to the following Figure for an example of the LCR data base print out.

```

7S MONITOR Eng. Ver. X.XY
DATE: 06/13/90 TIME: 11:16:29
ENTER PASSWORD:
adm>
  ENTER PROGRAM NO

adm>86
PRINT LCR TABLES
ENTER BUTTON NUMBER
adm>q
PRINT 3 DIGIT TABLE
ENTER RANGE, PRESS HOLD
adm>
3 DIGIT TABLE
  
```

CODE	LEADING 1			NON-LEADING 1		
	RR	PP	6	RR	PP	6
200	0	11	N	##	##	N
201	0	11	N	##	##	N
202	0	11	N	##	##	N
203	0	11	N	##	##	N
204	0	11	N	##	##	N
205	0	11	N	##	##	N
206	0	11	N	##	##	N
207	0	11	N	##	##	N
208	0	11	N	##	##	N
209	0	11	N	##	##	N
210	0	11	N	##	##	N
212	0	11	N	##	##	N
213	0	11	N	##	##	N
214	0	11	N	##	##	N
215	0	11	N	##	##	N
216	0	11	N	##	##	N
217	0	11	N	##	##	N
218	0	11	N	##	##	N
219	0	11	N	##	##	N
220	1	8	N	1	7	N
221	1	8	N	1	7	N
222	1	8	N	1	7	N
223	1	8	N	1	7	N
224	1	8	N	1	7	N
225	1	8	N	1	7	N
226	1	8	N	1	7	N
227	1	8	N	1	7	N
228	1	8	N	1	7	N
229	1	8	N	1	7	N
230	1	8	N	1	7	N
231	1	8	N	1	7	N
232	1	8	N	1	7	N
233	1	8	N	1	7	N
234	1	8	N	1	7	N
235	1	8	N	1	7	N
236	1	8	N	1	7	N
237	1	8	N	1	7	N
238	1	8	N	1	7	N
239	1	8	N	1	7	N
240	1	8	N	1	7	N
241	1	8	N	1	7	N
242	1	8	N	1	7	N
243	1	8	N	1	7	N
244	1	8	N	1	7	N
245	1	8	N	1	7	N
246	1	8	N	1	7	N
247	1	8	N	1	7	N
248	1	8	N	1	7	N
249	1	8	N	1	7	N
250	1	8	N	1	7	N
251	1	8	N	1	7	N
252	1	8	N	1	7	N
253	1	8	N	1	7	N
254	1	8	N	1	7	N
255	1	8	N	1	7	N
256	1	8	N	1	7	N
257	1	8	N	1	7	N
258	1	8	N	1	7	N
259	1	8	N	1	7	N
260	1	8	N	1	7	N
261	1	8	N	1	7	N
262	1	8	N	1	7	N
263	1	8	N	1	7	N
264	1	8	N	1	7	N
265	1	8	N	1	7	N
266	1	8	N	1	7	N
267	1	8	N	1	7	N
268	1	8	N	1	7	N
269	1	8	N	1	7	N
270	1	8	N	1	7	N
271	1	8	N	1	7	N
272	1	8	N	1	7	N
273	1	8	N	1	7	N
274	1	8	N	1	7	N
275	1	8	N	1	7	N
276	1	8	N	1	7	N
277	1	8	N	1	7	N
278	1	8	N	1	7	N
279	1	8	N	1	7	N
280	1	8	N	1	7	N
281	1	8	N	1	7	N
282	1	8	N	1	7	N
283	1	8	N	1	7	N
284	1	8	N	1	7	N
285	1	8	N	1	7	N
286	1	8	N	1	7	N
287	1	8	N	1	7	N
288	1	8	N	1	7	N
289	1	8	N	1	7	N
290	1	8	N	1	7	N
291	1	8	N	1	7	N
292	1	8	N	1	7	N
293	1	8	N	1	7	N
294	1	8	N	1	7	N
295	1	8	N	1	7	N
296	1	8	N	1	7	N
297	1	8	N	1	7	N
298	1	8	N	1	7	N
299	1	8	N	1	7	N
300	0	11	N	##	##	N
301	0	11	N	##	##	N
302	0	11	N	##	##	N
303	0	11	N	##	##	N
304	0	11	N	##	##	N
305	0	11	N	##	##	N
306	0	11	N	##	##	N
307	0	11	N	##	##	N
308	0	11	N	##	##	N
309	0	11	N	##	##	N
310	0	11	N	##	##	N
312	0	11	N	##	##	N
313	0	11	N	##	##	N
314	0	11	N	##	##	N
315	0	11	N	##	##	N
316	0	11	N	##	##	N
317	0	11	N	##	##	N
318	0	11	N	##	##	N
319	0	11	N	##	##	N
320	1	8	N	1	7	N
321	1	8	N	1	7	N
322	1	8	N	1	7	N
323	1	8	N	1	7	N
324	1	8	N	1	7	N
325	1	8	N	1	7	N
326	1	8	N	1	7	N
327	1	8	N	1	7	N
328	1	8	N	1	7	N
329	1	8	N	1	7	N
330	1	8	N	1	7	N
331	1	8	N	1	7	N

Figure 660-6 DB Printout of LCR Default

332	1	8	N	1	7	N	406	0	11	N	##	##	N
333	1	8	NN	1	7	NN	407	0	11	NN	##	##	NN
334	1	8	NN	1	7	NN	408	0	11	NN	##	##	NN
335	1	8	NN	1	7	NN	409	0	11	NN	##	##	NN
336	1	8	NN	1	7	NN	410	0	11	NN	##	##	NN
337	1	8	NN	1	7	NN	411	1	4	NN	##	3	NN
338	1	8	NN	1	7	NN	412	0	11	NN	##	##	NN
339	1	8	NN	1	7	NN	413	0	11	NN	##	##	NN
340	1	8	NN	1	7	NN	414	0	11	NN	##	##	NN
341	1	8	NN	1	7	NN	415	0	11	NN	##	##	NN
342	1	8	NN	1	7	NN	416	0	11	NN	##	##	NN
343	1	8	NN	1	7	NN	417	0	11	NN	##	##	NN
344	1	8	NN	1	7	NN	418	0	11	NN	##	##	NN
345	1	8	NN	1	7	NN	419	0	11	NN	##	##	NN
346	1	8	NN	1	7	NN	420	1	8	NN	##	7	NN
347	1	8	NN	1	7	NN	421	1	8	NN	##	7	NN
348	1	8	NN	1	7	NN	422	1	8	NN	##	7	NN
349	1	8	NN	1	7	NN	423	1	8	NN	##	7	NN
350	1	8	NN	1	7	NN	424	1	8	NN	##	7	NN
351	1	8	NN	1	7	NN	425	1	8	NN	##	7	NN
352	1	8	NN	1	7	NN	426	1	8	NN	##	7	NN
353	1	8	NN	1	7	NN	427	1	8	NN	##	7	NN
354	1	8	NN	1	7	NN	428	1	8	NN	##	7	NN
355	1	8	NN	1	7	NN	429	1	8	NN	##	7	NN
356	1	8	NN	1	7	NN	430	1	8	NN	##	7	NN
357	1	8	NN	1	7	NN	431	1	8	NN	##	7	NN
358	1	8	NN	1	7	NN	432	1	8	NN	##	7	NN
359	1	8	NN	1	7	NN	433	1	8	NN	##	7	NN
360	1	8	NN	1	7	NN	434	1	8	NN	##	7	NN
361	1	8	NN	1	7	NN	435	1	8	NN	##	7	NN
362	1	8	NN	1	7	NN	436	1	8	NN	##	7	NN
363	1	8	NN	1	7	NN	437	1	8	NN	##	7	NN
364	1	8	NN	1	7	NN	438	1	8	NN	##	7	NN
365	1	8	NN	1	7	NN	439	1	8	NN	##	7	NN
366	1	8	NN	1	7	NN	440	1	8	NN	##	7	NN
367	1	8	NN	1	7	NN	441	1	8	NN	##	7	NN
368	1	8	NN	1	7	NN	442	1	8	NN	##	7	NN
369	1	8	NN	1	7	NN	443	1	8	NN	##	7	NN
370	1	8	NN	1	7	NN	444	1	8	NN	##	7	NN
371	1	8	NN	1	7	NN	445	1	8	NN	##	7	NN
372	1	8	NN	1	7	NN	446	1	8	NN	##	7	NN
373	1	8	NN	1	7	NN	447	1	8	NN	##	7	NN
374	1	8	NN	1	7	NN	448	1	8	NN	##	7	NN
375	1	8	NN	1	7	NN	449	1	8	NN	##	7	NN
376	1	8	NN	1	7	NN	450	1	8	NN	##	7	NN
377	1	8	NN	1	7	NN	451	1	8	NN	##	7	NN
378	1	8	NN	1	7	NN	452	1	8	NN	##	7	NN
379	1	8	NN	1	7	NN	453	1	8	NN	##	7	NN
380	1	8	NN	1	7	NN	454	1	8	NN	##	7	NN
381	1	8	NN	1	7	NN	455	1	8	NN	##	7	NN
382	1	8	NN	1	7	NN	456	1	8	NN	##	7	NN
383	1	8	NN	1	7	NN	457	1	8	NN	##	7	NN
384	1	8	NN	1	7	NN	458	1	8	NN	##	7	NN
385	1	8	NN	1	7	NN	459	1	8	NN	##	7	NN
386	1	8	NN	1	7	NN	460	1	8	NN	##	7	NN
387	1	8	NN	1	7	NN	461	1	8	NN	##	7	NN
388	1	8	NN	1	7	NN	462	1	8	NN	##	7	NN
389	1	8	NN	1	7	NN	463	1	8	NN	##	7	NN
390	1	8	NN	1	7	NN	464	1	8	NN	##	7	NN
391	1	8	NN	1	7	NN	465	1	8	NN	##	7	NN
392	1	8	NN	1	7	NN	466	1	8	NN	##	7	NN
393	1	8	NN	1	7	NN	467	1	8	NN	##	7	NN
394	1	8	NN	1	7	NN	468	1	8	NN	##	7	NN
395	1	8	NN	1	7	NN	469	1	8	NN	##	7	NN
396	1	8	NN	1	7	NN	470	1	8	NN	##	7	NN
397	1	8	NN	1	7	NN	471	1	8	NN	##	7	NN
398	1	8	NN	1	7	NN	472	1	8	NN	##	7	NN
399	1	8	NN	1	7	NN	473	1	8	NN	##	7	NN
400	0	11	NN	##	##	NN	474	1	8	NN	##	7	NN
401	0	11	NN	##	##	NN	475	1	8	NN	##	7	NN
402	0	11	NN	##	##	NN	476	1	8	NN	##	7	NN
403	0	11	NN	##	##	NN	477	1	8	NN	##	7	NN
404	0	11	NN	##	##	NN	478	1	8	NN	##	7	NN
405	0	11	NN	##	##	NN	479	1	8	NN	##	7	NN

Figure 660-6 DB Printout of LCR Default (Cont'd)

480	1	8	N	1	7	N	555	1	8	N	1	7	N
481	1	8	NN	1	7	NN	556	1	8	NN	1	7	NN
482	1	8	NN	1	7	NN	557	1	8	NN	1	7	NN
483	1	8	NN	1	7	NN	558	1	8	NN	1	7	NN
484	1	8	NN	1	7	NN	559	1	8	NN	1	7	NN
485	1	8	NN	1	7	NN	560	1	8	NN	1	7	NN
486	1	8	NN	1	7	NN	561	1	8	NN	1	7	NN
487	1	8	NN	1	7	NN	562	1	8	NN	1	7	NN
488	1	8	NN	1	7	NN	563	1	8	NN	1	7	NN
489	1	8	NN	1	7	NN	564	1	8	NN	1	7	NN
490	1	8	NN	1	7	NN	565	1	8	NN	1	7	NN
491	1	8	NN	1	7	NN	566	1	8	NN	1	7	NN
492	1	8	NN	1	7	NN	567	1	8	NN	1	7	NN
493	1	8	NN	1	7	NN	568	1	8	NN	1	7	NN
494	1	8	NN	1	7	NN	569	1	8	NN	1	7	NN
495	1	8	NN	1	7	NN	570	1	8	NN	1	7	NN
496	1	8	NN	1	7	NN	571	1	8	NN	1	7	NN
497	1	8	NN	1	7	NN	572	1	8	NN	1	7	NN
498	1	8	NN	1	7	NN	573	1	8	NN	1	7	NN
499	1	8	NN	1	7	NN	574	1	8	NN	1	7	NN
500	0	11	NN	##	##	NN	575	1	8	NN	1	7	NN
501	0	11	NN	##	##	NN	576	1	8	NN	1	7	NN
502	0	11	NN	##	##	NN	577	1	8	NN	1	7	NN
503	0	11	NN	##	##	NN	578	1	8	NN	1	7	NN
504	0	11	NN	##	##	NN	579	1	8	NN	1	7	NN
505	0	11	NN	##	##	NN	580	1	8	NN	1	7	NN
506	0	11	NN	##	##	NN	581	1	8	NN	1	7	NN
507	0	11	NN	##	##	NN	582	1	8	NN	1	7	NN
508	0	11	NN	##	##	NN	583	1	8	NN	1	7	NN
509	0	11	NN	##	##	NN	584	1	8	NN	1	7	NN
510	0	11	NN	##	##	NN	585	1	8	NN	1	7	NN
512	0	11	NN	##	##	NN	586	1	8	NN	1	7	NN
513	0	11	NN	##	##	NN	587	1	8	NN	1	7	NN
514	0	11	NN	##	##	NN	588	1	8	NN	1	7	NN
515	0	11	NN	##	##	NN	589	1	8	NN	1	7	NN
516	0	11	NN	##	##	NN	590	1	8	NN	1	7	NN
517	0	11	NN	##	##	NN	591	1	8	NN	1	7	NN
518	0	11	NN	##	##	NN	592	1	8	NN	1	7	NN
519	0	11	NN	##	##	NN	593	1	8	NN	1	7	NN
520	1	8	NN	1	7	NN	594	1	8	NN	1	7	NN
521	1	8	NN	1	7	NN	595	1	8	NN	1	7	NN
522	1	8	NN	1	7	NN	596	1	8	NN	1	7	NN
523	1	8	NN	1	7	NN	597	1	8	NN	1	7	NN
524	1	8	NN	1	7	NN	598	1	8	NN	1	7	NN
525	1	8	NN	1	7	NN	599	1	8	NN	1	7	NN
526	1	8	NN	1	7	NN	600	0	11	NN	##	##	NN
527	1	8	NN	1	7	NN	601	0	11	NN	##	##	NN
528	1	8	NN	1	7	NN	602	0	11	NN	##	##	NN
529	1	8	NN	1	7	NN	603	0	11	NN	##	##	NN
530	1	8	NN	1	7	NN	604	0	11	NN	##	##	NN
531	1	8	NN	1	7	NN	605	0	11	NN	##	##	NN
532	1	8	NN	1	7	NN	606	0	11	NN	##	##	NN
533	1	8	NN	1	7	NN	607	0	11	NN	##	##	NN
534	1	8	NN	1	7	NN	608	0	11	NN	##	##	NN
535	1	8	NN	1	7	NN	609	0	11	NN	##	##	NN
536	1	8	NN	1	7	NN	610	0	11	NN	##	##	NN
537	1	8	NN	1	7	NN	612	0	11	NN	##	##	NN
538	1	8	NN	1	7	NN	613	0	11	NN	##	##	NN
539	1	8	NN	1	7	NN	614	0	11	NN	##	##	NN
540	1	8	NN	1	7	NN	615	0	11	NN	##	##	NN
541	1	8	NN	1	7	NN	616	0	11	NN	##	##	NN
542	1	8	NN	1	7	NN	617	0	11	NN	##	##	NN
543	1	8	NN	1	7	NN	618	0	11	NN	##	##	NN
544	1	8	NN	1	7	NN	619	0	11	NN	##	##	NN
545	1	8	NN	1	7	NN	620	1	8	NN	1	7	NN
546	1	8	NN	1	7	NN	621	1	8	NN	1	7	NN
547	1	8	NN	1	7	NN	622	1	8	NN	1	7	NN
548	1	8	NN	1	7	NN	623	1	8	NN	1	7	NN
549	1	8	NN	1	7	NN	624	1	8	NN	1	7	NN
550	1	8	NN	1	7	NN	625	1	8	NN	1	7	NN
551	1	8	NN	1	7	NN	626	1	8	NN	1	7	NN
552	1	8	NN	1	7	NN	627	1	8	NN	1	7	NN
553	1	8	NN	1	7	NN	628	1	8	NN	1	7	NN
554	1	8	NN	1	7	NN	629	1	8	NN	1	7	NN

Figure 660-6 DB Printout of LCR Default (Cont'd)

630	1	8	N	1	7	N	704	0	11	N	##	##	N
631	1	8	N	1	7	NN	705	0	0	11	NN	##	NN
632	1	8	N	1	7	NN	706	0	0	11	NN	##	NN
633	1	8	N	1	7	NN	707	0	0	11	NN	##	NN
634	1	8	N	1	7	NN	708	0	0	11	NN	##	NN
635	1	8	N	1	7	NN	709	0	0	11	NN	##	NN
636	1	8	N	1	7	NN	710	0	0	11	NN	##	NN
637	1	8	N	1	7	NN	712	0	0	11	NN	##	NN
638	1	8	N	1	7	NN	713	0	0	11	NN	##	NN
639	1	8	N	1	7	NN	714	0	0	11	NN	##	NN
640	1	8	N	1	7	NN	715	0	0	11	NN	##	NN
641	1	8	N	1	7	NN	716	0	0	11	NN	##	NN
642	1	8	N	1	7	NN	717	0	0	11	NN	##	NN
643	1	8	N	1	7	NN	718	0	0	11	NN	##	NN
644	1	8	N	1	7	NN	719	0	0	11	NN	##	NN
645	1	8	N	1	7	NN	720	1	8	NN	##	7	NN
646	1	8	N	1	7	NN	721	1	8	NN	1	7	NN
647	1	8	N	1	7	NN	722	1	8	NN	1	7	NN
648	1	8	N	1	7	NN	723	1	8	NN	1	7	NN
649	1	8	N	1	7	NN	724	1	8	NN	1	7	NN
650	1	8	N	1	7	NN	725	1	8	NN	1	7	NN
651	1	8	N	1	7	NN	726	1	8	NN	1	7	NN
652	1	8	N	1	7	NN	727	1	8	NN	1	7	NN
653	1	8	N	1	7	NN	728	1	8	NN	1	7	NN
654	1	8	N	1	7	NN	729	1	8	NN	1	7	NN
655	1	8	N	1	7	NN	730	1	8	NN	1	7	NN
656	1	8	N	1	7	NN	731	1	8	NN	1	7	NN
657	1	8	N	1	7	NN	732	1	8	NN	1	7	NN
658	1	8	N	1	7	NN	733	1	8	NN	1	7	NN
659	1	8	N	1	7	NN	734	1	8	NN	1	7	NN
660	1	8	N	1	7	NN	735	1	8	NN	1	7	NN
661	1	8	N	1	7	NN	736	1	8	NN	1	7	NN
662	1	8	N	1	7	NN	737	1	8	NN	1	7	NN
663	1	8	N	1	7	NN	738	1	8	NN	1	7	NN
664	1	8	N	1	7	NN	739	1	8	NN	1	7	NN
665	1	8	N	1	7	NN	740	1	8	NN	1	7	NN
666	1	8	N	1	7	NN	741	1	8	NN	1	7	NN
667	1	8	N	1	7	NN	742	1	8	NN	1	7	NN
668	1	8	N	1	7	NN	743	1	8	NN	1	7	NN
669	1	8	N	1	7	NN	744	1	8	NN	1	7	NN
670	1	8	N	1	7	NN	745	1	8	NN	1	7	NN
671	1	8	N	1	7	NN	746	1	8	NN	1	7	NN
672	1	8	N	1	7	NN	747	1	8	NN	1	7	NN
673	1	8	N	1	7	NN	748	1	8	NN	1	7	NN
674	1	8	N	1	7	NN	749	1	8	NN	1	7	NN
675	1	8	N	1	7	NN	750	1	8	NN	1	7	NN
676	1	8	N	1	7	NN	751	1	8	NN	1	7	NN
677	1	8	N	1	7	NN	752	1	8	NN	1	7	NN
678	1	8	N	1	7	NN	753	1	8	NN	1	7	NN
679	1	8	N	1	7	NN	754	1	8	NN	1	7	NN
680	1	8	N	1	7	NN	755	1	8	NN	1	7	NN
681	1	8	N	1	7	NN	756	1	8	NN	1	7	NN
682	1	8	N	1	7	NN	757	1	8	NN	1	7	NN
683	1	8	N	1	7	NN	758	1	8	NN	1	7	NN
684	1	8	N	1	7	NN	759	1	8	NN	1	7	NN
685	1	8	N	1	7	NN	760	1	8	NN	1	7	NN
686	1	8	N	1	7	NN	761	1	8	NN	1	7	NN
687	1	8	N	1	7	NN	762	1	8	NN	1	7	NN
688	1	8	N	1	7	NN	763	1	8	NN	1	7	NN
689	1	8	N	1	7	NN	764	1	8	NN	1	7	NN
690	1	8	N	1	7	NN	765	1	8	NN	1	7	NN
691	1	8	N	1	7	NN	766	1	8	NN	1	7	NN
692	1	8	N	1	7	NN	767	1	8	NN	1	7	NN
693	1	8	N	1	7	NN	768	1	8	NN	1	7	NN
694	1	8	N	1	7	NN	769	1	8	NN	1	7	NN
695	1	8	N	1	7	NN	770	1	8	NN	1	7	NN
696	1	8	N	1	7	NN	771	1	8	NN	1	7	NN
697	1	8	N	1	7	NN	772	1	8	NN	1	7	NN
698	1	8	N	1	7	NN	773	1	8	NN	1	7	NN
699	1	8	N	1	7	NN	774	1	8	NN	1	7	NN
700	0	11	NN	##	##	NN	775	1	8	NN	1	7	NN
701	0	11	NN	##	##	NN	776	1	8	NN	1	7	NN
702	0	11	NN	##	##	NN	777	1	8	NN	1	7	NN
703	0	11	NN	##	##	NN	778	1	8	NN	1	7	NN

Figure 660-6 DB Printout of LCR Default (Cont'd)

779	1	8	N	1	7	N	854	1	8	N	1	7	N
780	1	8	NN	1	7	NN	855	1	8	NN	1	7	NN
781	1	8	NN	1	7	NN	856	1	8	NN	1	7	NN
782	1	8	NN	1	7	NN	857	1	8	NN	1	7	NN
783	1	8	NN	1	7	NN	858	1	8	NN	1	7	NN
784	1	8	NN	1	7	NN	859	1	8	NN	1	7	NN
785	1	8	NN	1	7	NN	860	1	8	NN	1	7	NN
786	1	8	NN	1	7	NN	861	1	8	NN	1	7	NN
787	1	8	NN	1	7	NN	862	1	8	NN	1	7	NN
788	1	8	NN	1	7	NN	863	1	8	NN	1	7	NN
789	1	8	NN	1	7	NN	864	1	8	NN	1	7	NN
790	1	8	NN	1	7	NN	865	1	8	NN	1	7	NN
791	1	8	NN	1	7	NN	866	1	8	NN	1	7	NN
792	1	8	NN	1	7	NN	867	1	8	NN	1	7	NN
793	1	8	NN	1	7	NN	868	1	8	NN	1	7	NN
794	1	8	NN	1	7	NN	869	1	8	NN	1	7	NN
795	1	8	NN	1	7	NN	870	1	8	NN	1	7	NN
796	1	8	NN	1	7	NN	871	1	8	NN	1	7	NN
797	1	8	NN	1	7	NN	872	1	8	NN	1	7	NN
798	1	8	NN	1	7	NN	873	1	8	NN	1	7	NN
799	1	8	NN	1	7	NN	874	1	8	NN	1	7	NN
800	0	11	NN	##	##	NN	875	1	8	NN	1	7	NN
801	0	11	NN	##	##	NN	876	1	8	NN	1	7	NN
802	0	11	NN	##	##	NN	877	1	8	NN	1	7	NN
803	0	11	NN	##	##	NN	878	1	8	NN	1	7	NN
804	0	11	NN	##	##	NN	879	1	8	NN	1	7	NN
805	0	11	NN	##	##	NN	880	1	8	NN	1	7	NN
806	0	11	NN	##	##	NN	881	1	8	NN	1	7	NN
807	0	11	NN	##	##	NN	882	1	8	NN	1	7	NN
808	0	11	NN	##	##	NN	883	1	8	NN	1	7	NN
809	0	11	NN	##	##	NN	884	1	8	NN	1	7	NN
810	0	11	NN	##	##	NN	885	1	8	NN	1	7	NN
812	0	11	NN	##	##	NN	886	1	8	NN	1	7	NN
813	0	11	NN	##	##	NN	887	1	8	NN	1	7	NN
814	0	11	NN	##	##	NN	888	1	8	NN	1	7	NN
815	0	11	NN	##	##	NN	889	1	8	NN	1	7	NN
816	0	11	NN	##	##	NN	890	1	8	NN	1	7	NN
817	0	11	NN	##	##	NN	891	1	8	NN	1	7	NN
818	0	11	NN	##	##	NN	892	1	8	NN	1	7	NN
819	0	11	NN	##	##	NN	893	1	8	NN	1	7	NN
820	1	8	NN	1	7	NN	894	1	8	NN	1	7	NN
821	1	8	NN	1	7	NN	895	1	8	NN	1	7	NN
822	1	8	NN	1	7	NN	896	1	8	NN	1	7	NN
823	1	8	NN	1	7	NN	897	1	8	NN	1	7	NN
824	1	8	NN	1	7	NN	898	1	8	NN	1	7	NN
825	1	8	NN	1	7	NN	899	1	8	NN	1	7	NN
826	1	8	NN	1	7	NN	900	0	11	NN	##	##	NN
827	1	8	NN	1	7	NN	901	0	11	NN	##	##	NN
828	1	8	NN	1	7	NN	902	0	11	NN	##	##	NN
829	1	8	NN	1	7	NN	903	0	11	NN	##	##	NN
830	1	8	NN	1	7	NN	904	0	11	NN	##	##	NN
831	1	8	NN	1	7	NN	905	0	11	NN	##	##	NN
832	1	8	NN	1	7	NN	906	0	11	NN	##	##	NN
833	1	8	NN	1	7	NN	907	0	11	NN	##	##	NN
834	1	8	NN	1	7	NN	908	0	11	NN	##	##	NN
835	1	8	NN	1	7	NN	909	0	11	NN	##	##	NN
836	1	8	NN	1	7	NN	910	0	11	NN	##	##	NN
837	1	8	NN	1	7	NN	911	1	4	NN	1	3	NN
838	1	8	NN	1	7	NN	912	0	11	NN	##	##	NN
839	1	8	NN	1	7	NN	913	0	11	NN	##	##	NN
840	1	8	NN	1	7	NN	914	0	11	NN	##	##	NN
841	1	8	NN	1	7	NN	915	0	11	NN	##	##	NN
842	1	8	NN	1	7	NN	916	0	11	NN	##	##	NN
843	1	8	NN	1	7	NN	917	0	11	NN	##	##	NN
844	1	8	NN	1	7	NN	918	0	11	NN	##	##	NN
845	1	8	NN	1	7	NN	919	0	11	NN	##	##	NN
846	1	8	NN	1	7	NN	920	1	8	NN	1	7	NN
847	1	8	NN	1	7	NN	921	1	8	NN	1	7	NN
848	1	8	NN	1	7	NN	922	1	8	NN	1	7	NN
849	1	8	NN	1	7	NN	923	1	8	NN	1	7	NN
850	1	8	NN	1	7	NN	924	1	8	NN	1	7	NN
851	1	8	NN	1	7	NN	925	1	8	NN	1	7	NN
852	1	8	NN	1	7	NN	926	1	8	NN	1	7	NN
853	1	8	NN	1	7	NN	927	1	8	NN	1	7	NN

Figure 660-6 DB Printout of LCR Default (Cont'd)

928	1	8	N	1	7	N
929	1	8	N	1	7	N
930	1	8	N	1	7	N
931	1	8	N	1	7	N
932	1	8	N	1	7	N
933	1	8	N	1	7	N
934	1	8	N	1	7	N
935	1	8	N	1	7	N
936	1	8	N	1	7	N
937	1	8	N	1	7	N
938	1	8	N	1	7	N
939	1	8	N	1	7	N
940	1	8	N	1	7	N
941	1	8	N	1	7	N
942	1	8	N	1	7	N
943	1	8	N	1	7	N
944	1	8	N	1	7	N
945	1	8	N	1	7	N
946	1	8	N	1	7	N
947	1	8	N	1	7	N
948	1	8	N	1	7	N
949	1	8	N	1	7	N
950	1	8	N	1	7	N
951	1	8	N	1	7	N
952	1	8	N	1	7	N
953	1	8	N	1	7	N
954	1	8	N	1	7	N
955	1	8	N	1	7	N
956	1	8	N	1	7	N
957	1	8	N	1	7	N
958	1	8	N	1	7	N
959	1	8	N	1	7	N
960	1	8	N	1	7	N
961	1	8	N	1	7	N
962	1	8	N	1	7	N
963	1	8	N	1	7	N
964	1	8	N	1	7	N
965	1	8	N	1	7	N
966	1	8	N	1	7	N
967	1	8	N	1	7	N
968	1	8	N	1	7	N
969	1	8	N	1	7	N
970	1	8	N	1	7	N
971	1	8	N	1	7	N
972	1	8	N	1	7	N
973	1	8	N	1	7	N
974	1	8	N	1	7	N
975	1	8	N	1	7	N
976	1	8	N	1	7	N
977	1	8	N	1	7	N
978	1	8	N	1	7	N
979	1	8	N	1	7	N
980	1	8	N	1	7	N
981	1	8	N	1	7	N
982	1	8	N	1	7	N
983	1	8	N	1	7	N
984	1	8	N	1	7	N
985	1	8	N	1	7	N
986	1	8	N	1	7	N
987	1	8	N	1	7	N
988	1	8	N	1	7	N
989	1	8	N	1	7	N
990	1	8	N	1	7	N
991	1	8	N	1	7	N
992	1	8	N	1	7	N
993	1	8	N	1	7	N
994	1	8	N	1	7	N
995	1	8	N	1	7	N
996	1	8	N	1	7	N
997	1	8	N	1	7	N
998	1	8	N	1	7	N
999	1	8	N	1	7	N

Figure 660-6 DB Printout of LCR Default (Cont'd)

System Data Base Printouts (Cont'd)

B. 6-Digit Tables

Programming StepsDescription

To print the six (6) digit table:

1. Press the 6-DIG TBL flexible button (button #2). The following message will be shown on the display phone:

PRINT 6 DIGIT TABLE
ENTER RANGE, PRESS HOLD

2. Enter the range of area codes (200 - 919) that a print out is desired (enter the area codes that represent the tables to be printed).
3. Press HOLD. If a print out of all 6 digit tables are desired you may skip step 1 above and simply just press HOLD.

When all requested data has been sent to the printer confirmation tone will be heard.

```
adm>w
PRINT 6 DIGIT TABLE
ENTER RANGE, PRESS HOLD
adm>
6 DIGIT TABLE
-----
AREA ROUTE OFFICE CODES
CODE NO
-----
(no default entries)
```

```
adm>m
exiting admin...
```

C. Exception Table

Programming StepsDescription

To print the exception table:

1. Press the EXCEPT TBL flexible button (button #3). The following message will be shown on the display phone:

PRINT EXCEPTION TABLE
ENTER RANGE, PRESS HOLD

2. Enter the range of exception codes (00 - 99) that a print out is desired.
3. Press HOLD. If a print out of all exception codes are desired you may skip step 1 above and simply just press HOLD.

When all requested data has been sent to the printer confirmation tone will be heard.

```
adm>e
PRINT EXCEPTION TABLE
ENTER RANGE, PRESS HOLD
adm>
EXCEPTION CODE TABLE
-----
CODE ROUTE NO
-----
(no default entries)
```

```
adm>m
exiting admin...
```

System Data Base Printouts (Cont'd)

D. Route List Table

Programming Steps

Description

To print the Route List table:

1. Press the ROUTE LIST flexible button (button #4). The following message will be shown on the display phone:

PRINT ROUTE LIST TABLE
ENTER RANGE, PRESS HOLD

2. Enter the range of Route List tables (00 - 15) that a print out is desired.
3. Press HOLD. If a print out of all Route List Tables are desired you may skip step 1 above and simply just press HOLD.

When all requested data has been sent to the printer confirmation tone will be heard.

```
adm>r
PRINT ROUTE LIST TABLE
ENTER RANGE, PRESS HOLD
adm>
ROUTE LIST TABLE
-----
RT TIME CO GRP INS/DEL GRP PR
0 1 1 ## 1
2 1 1 ## 1
3 1 1 ## 1
4 1 1 ## 1
1 1 1 ## 1
2 1 1 ## 1
3 1 1 ## 1
4 1 1 ## 1
(no default entries for
Routes 2 - 15)
adm>m
exiting admin...
```

E. Insert / Delete Table

Programming Steps

Description

To print the Insert delete tables:

1. Press the INS/DEL TBL flexible button (button #5). The following message will be shown on the display of the display phone;

PRINT DIGIT INSERT/DEL
ENTER RANGE, PRESS HOLD

2. Enter the range of Insert Delete tables (00 - 19) that a print out is desired.
3. Press HOLD. If a print out of all Insert Delete Tables are desired you may skip step 1 above and simply just press HOLD.

When all requested data has been sent to the printer confirmation tone will be heard.

```
adm>a
PRINT DIGIT INSERT/DEL
ENTER RANGE, PRESS HOLD
adm>
DIGIT INS/DEL TABLE
-----
TABLE DIGITS
(no default entries)
adm>m
exiting admin...
```

System Data Base Printouts (Cont'd)

F. Daily Start Time Table

Programming Steps

Description

To print the Daily Start Time table:

1. Press the DAILY START flexible button (button #6). The following message will be shown on the display phone:

PRINT DAILY START TIME
ENTER RANGE, PRESS HOLD

2. Press the HOLD button.

When all requested data has been sent to the printer confirmation tone will be heard.

```
adm>s
PRINT DAILY START TIME
PRESS HOLD
adm>
DAILY START TIME TABLE
```

TABLE	TIME
1	800
2	1700
3	2300
4	####

```
adm>m
exiting admin...
```

G. Weekly Schedule Table

Programming Steps

Description

To print the Weekly Schedule table:

1. Press the WEEKLY SCHED flexible button (button #7). The following message will be shown on the display phone:

PRINT WEEKLY SCHEDULE
ENTER RANGE, PRESS HOLD

2. Press the HOLD button.

When all requested data has been sent to the printer confirmation tone will be heard.

```
adm>d
PRINT WEEKLY SCHEDULE
PRESS HOLD
adm>
WEEKLY SCHEDULE TABLE
```

START TIME	M	T	W	T	F	S	S
800	1	1	1	1	1	3	3
1700	2	2	2	2	2	3	2
2300	3	3	3	3	3	3	3
####	3	3	3	3	3	3	3

```
adm>m
exiting admin...
```

System Data Base Printouts (Cont'd)

H. Toll Information Route

Programming StepsDescription

To print the Toll Information route:

1. Press the TOLL INFO flexible button (button #8). The following message will be shown on the display phone:



LCR ROUTE 555-1212
##

```
adm>f
LCR ROUTE 555-1212
##
adm>
LCR ROUTE FOR 555-1212
```

```
##
```

```
adm>m
exiting admin...
```

2. Press the HOLD button.

When all requested data has been sent to the printer confirmation tone will be heard.

SECTION 700

SYSTEM CHECKOUT

700.1 INTRODUCTION

Prior to actual power up and initialization, the Key System should be checked over to avoid start up delays or improper loading. A step-by-step checklist is provided for this purpose.

700.2 PRELIMINARY PROCEDURES

1. Verify that the DC output power cord from the EPH2 housing is plugged into the DC connector on the BKSU.
2. Make sure that the BKSU and EPH2 are properly grounded.
3. The DC/DC Converter must be installed in the KSU and firmly seated in its card connector position.
4. The ON/OFF switches of the EPH2 housing and the BKSU should be OFF. The breaker switch of the EPH2 should be ON.
5. Verify that all PCB's are firmly plugged into the correct color coded card slot positions. This can be done by comparing the color of the PCB ejector tabs with the colored labels on the KSU shelves.
6. The service switches on the PCB's should be in the NORMAL (up) position.
7. Inspect the MDF for shorted wiring and improper polarity that would affect the Key Telephone or DSS console.
8. All switches on the CPB should be ON so that default data can be loaded into memory when the system is powered up. Make certain that the lithium battery is connected to the battery (+) terminal.
9. Make sure that plug-ended MDF cables connected to the KSU are secure and are plugged into the correct position.

700.3 POWER UP SEQUENCE

The power up sequence involves the proper application of AC power to the System, monitoring DC/DC Converter and CPB LED's. A successful power up is assured if the installation checklist has been followed. When System power is turned on, default data is loaded into memory.

1. The eight white DIP switches on the front of the CPB should all be in the ON position.
2. Plug the AC power cord of the EPH2 housing into the dedicated 117V ac outlet. Turn the power switch on the EPH2 to on. The input and output LED's on the power supply should light. The AC and DC, LED's on the front of the EPH2 should light.
3. Turn the power switch of the BKSU to ON. The EPH2 ring LED will now flicker (If RG unit is installed).
4. The two red LED's on the DC/DC Converter should light immediately.
5. The CPB has eight red LED's located on the front of the card. If the power up is successful LED's one, two, and three will light steady and then go off. LED eight will light and remain lit. LED five will flicker. LED's two and three will flicker faintly.
6. Press the reset button on the CPB. The above CPB LED indications will repeat.
7. Check for +5V and +14V operation on the DC/DC Converter and adjust the +5V, if necessary. A digital volt meter is required to adjust the 5 volts.
8. Turn switch eight on the CPB to off to prevent accidental loading of default data in case of power outage.
9. The system is ready for programming. If any problems have occurred, Refer to Section 800, Maintenance and Troubleshooting.

96EX Power Supply Tests

DC/DC CONVERTER*			
VOLTAGE DESIGNATION	VOLTAGE READING	TEST POINT LOCATION	REMARKS
+5 VDC	+5 VDC \pm 1%	Front of DC/DC Converter	Adjustable on front cover of DC/DC Converter
+14 VDC	+14 VDC \pm 4%	Front of DC/DC Converter	

*The DC/DC Converter is pre-set at the time of manufacturing, but should be checked at system initialization with a digital volt meter having an accuracy of \pm 1%.

POWER SUPPLY			
VOLTAGE DESIGNATION	TEST POINT LOCATION	TEST POINT LOCATION	TEST POINT LOCATION
117 VAC	+117 VAC \pm 10%	Commercial Power Source	If 24V is below 22V or above 29V, check AC power for 117 \pm 10%. No adjustments
+24 VDC	+24 VDC \pm 5%	DC output terminals	

SECTION 800

MAINTENANCE AND TROUBLESHOOTING

800.1 PRINTED CIRCUIT BOARD (PCB) TROUBLESHOOTING CHARTS

Table 800-1 Central Processing Board (CPB)

KTU	FUNCTION	CONTROL	OPTIONS	FAULT OPTIONS
CPB Color Code: Yellow	1. Central Processor Board (CPB) to control system operation. 2. Read Only Memory (ROM) with factory set instructions. 3. Random Access Memory (RAM) protected by a lithium battery. 4. Hard Restart switch for manual system restart. 5. Provides RS-232C port for SMDR and Terminal/Remote Programming.	Contains 8 process running indicators (LEDs) which indicate various conditions of the system. LED 1 - Dependability/Recovery Flickers on/off in normal operation. LED 2 - Ringing Will flash steady when ring scan is functioning. LED 3 - Timers Will flicker when timers are operating. LED 4 - Monitor LED 5 - LCD LED 6 - Call Processing LED 7 - Administration LED 8 - Idle. If the system stops processing and LED 1 only is on, this indicates a ROM failure. If the system halts and LEDs 1 and 2 are on, this indicates a RAM failure.	Switch 1 - Write Memory OFF - Protects contents of database. ON - Allows update of the database from Station 100. Switch 2 - Clear to Send OFF - For terminal equipped to send CTS signal. ON - Is normal terminal operation. Switch 3 - Trace Mode. ON - Allows trace output OFF - No trace output. Switch 4 - Soft Restart OFF - No soft restart. ON - Allows soft restart. Switch 5 - SMDR. OFF - Disabled. ON - Enabled.	1. Complete system failure. 2. Erroneous call processing. 3. Inoperative features in system operation. 4. Partial failures in system operation. 5. Continual system restarts. 6. Failure of SMDR. 7. Loss of unique customer data-base programming.

Table 800-1 Central Processing Board (CPB) (Cont'd)

KTU	FUNCTION	CONTROL	OPTIONS	FAULT OPTIONS
CPB (Cont'd) Color Code: Yellow			Switch 6 - Printer Type: OFF- Normal type 29-Character. ON- Wide type 80-Character. Switch 7 - SMDR. OFF - SMDR goes to CPB port. ON - SMDR goes to APB port. Switch 8 - Initialization Protect. OFF - Database will not initialize. ON - Database will be initialized.	

Table 800-2 DC/DC Converter Unit (DC/DC)

KTU	FUNCTION	CONTROL	OPTIONS	FAULT OPTIONS
DC/DC Converter.	Provides 5-14V logic voltages from PS. Provides LED indications if voltages are present. Provides BGM1 connection.	1.Receives 24V DC from PS. 2.BGM Volume.		1.Total system failure - no LEDs or voice. 2.Loss of music on-hold and BGM.

Table 800-3 Battery Charging Board (BC)

KTU	FUNCTION	CONTROL	OPTIONS	FAULT OPTIONS
Battery Charging Board (BC) (Located in the EPH2).	Charges external battery package.	Contains relays and circuitry to charge batteries and to switch to battery when AC power fails.	The TEU switch turns on and off the audible alarm when in the battery mode.	1.Battery Backup failure.

Table 800-4 Key Station Interface Board (KIB)

KTU	FUNCTION	CONTROL	OPTIONS	FAULT OPTIONS
KIB Color Code: Green	Provides interface for 8 key telephones.	Busy state LED that monitors circuits for busy condition. Service switch with Normal/Service mode.	None	1.Unable to receive intercom dial tone. 2.Poor transmission characteristics. 3.Key telephone set inoperative. 4.Key telephone unable to invoke features 5.No LED indications.

Table 800-5 Central Office Interface Board (COB)

KTU	FUNCTION	CONTROL	OPTIONS	FAULT OPTIONS
COB Color Code: White	Provides interface for 8 CO/PBX lines.	Busy state LED that monitors circuits for busy condition. Service switch with Normal/Service mode.	None.	1.Unable to receive CO dial tone. 2.Unable to break CO dial tone. 3.CO line(s) not ringing.

Table 800-6 Single Line Interface Board (SIB)

KTU	FUNCTION	CONTROL	OPTIONS	FAULT OPTIONS
SIB Color Code: Green	Provides interface for 8 SLTs. Contains the matrix for CO and intercom paths. Also provides for SLTs with M/W lights.	Busy state LED that monitors circuits for busy condition. Service switch with Normal/Service mode.	None.	1.SLT can't receive dial tone. 2.Poor transmission characteristics.

Table 800-7 SLT Ring Generator (RG) and M/W Power Supply

KTU	FUNCTION	CONTROL	OPTIONS	FAULT OPTIONS
Single Line Ring Generator and M/W Power Supply. (RG). (Located in EPH2)	Mounted in the EPH2, the RG provides 90 VAC 20 Hz ring supply to support SLTs. Also provides voltage to light M/W lamps on SLTs equipped with M/W lamps.	None.	None.	1.SLTs won't ring. 2.M/W light will not function properly on all SLTs.

Table 800-8 Application Board (APL)

KTU	FUNCTION	CONTROL	OPTIONS	FAULT OPTIONS
Application Board Color Code: Red	Provides 2 DTMF receivers and 2 DTMF senders for SLTs and DISA. Matrix and control circuitry for DISA, unsupervised conference, 1 external page port and supports SLU module and additional RS232C module (RSM) 1 RAN port w/E&M type contacts for external recorded announcement devices.	None.	RSM Module. RS232C Module.	1.DISA circuit does not work. 2.Loss of external page. 3.SLT cannot receive intercom dial tone.

Table 800-9 Single Line Receiver/Sender Unit (SLU)

KTU	FUNCTION	CONTROL	OPTIONS	FAULT OPTIONS
Single Line. DTMF Module (SLU) Added to APB Board.	Used to expand the DTMF receivers and senders in system to support SLTs.	Adds 4 DTMF receivers and 1 DTMF sender.	None.	None.

Table 800-10 RS-232C Module (RSM)

KTU	FUNCTION	CONTROL	OPTIONS	FAULT OPTIONS
RS232C Module (RSM) Added to APB Board.	Provides 2nd RS232C port to system for deidcated SMDR port.	None.	Selection switches on RSM Module determine the Baud Rate of data sent through 2nd RS232C port.	1.Loss of SMDR data.

Table 800-11 Power Failure Transfer Unit (PFT)

KTU	FUNCTION	CONTROL	OPTIONS	FAULT OPTIONS
Power Failure Transfer Unit (PFT)	Provides relay transfer circuits for up to 6 CO lines in the event of a power or processor failure. Facilitates Loud Bell ringing AND CO Control Contacts	None.	Manual switch used for activating the PFT for testing purposes.	1.Power Failure Transfer does not function. 2.Loud Bells do not ring.

Table 800-12 Amplified Conference Board (COA)

KTU	FUNCTION	CONTROL	OPTIONS	FAULT OPTIONS
Amplified Central Office (COA) Color Code: White	Provides interface for 8 CO lines with the ability to add 3 db of gain on a per circuit basis.	Busy state LED that monitors each CO line for ringing, busy, and idle conditions. Service switch with Normal/Service mode.	8 jumper straps to set gain at 0 db or +3 db for use in conference calls and Trunk to Trunk DISA calls.	1.Unable to receive Co dial tone. 2.Unable to break CO dial tone. 3.CO line(s) not ringing. 4.Crosstalk/Noise.

Table 800-13 Off-Premise Extension Board (OPX)

KTU	FUNCTION	CONTROL	OPTIONS	FAULT OPTIONS
Off Premise Extension (OPX) Color Code: Green	Provides four (4) 48 volt loop to interface OPX circuits. Contains matrix for CO and ICM ports.	Busy state LED that monitors circuits for busy condition. Service switch with Normal/Service mode.	None.	1.SLT can't receive dial tone. 2.Poor transmission characteristics.

800.2 REMOTE MAINTENANCE

A. General Overview

The Remote Maintenance feature allows authorized personnel to survey system and slot configuration information. This can be done through a modem or data terminal connected to the system CPB via the RS-232C port. The commands are entered from a keyboard and are limited to those listed.

B. Overview of Maintenance Commands

There are four (4) basic commands available in the Remote Maintenance feature. All commands begin with a single character, followed by a space, another character and an optional digit or digits. All commands are terminated with a carriage return.

Basic format of the commands are shown in Figure 800-1:

C. Maintenance Password

The Remote Maintenance feature, like Remote Programming, is entered via a six-character alphanumeric string. The password prompt is given by entering a carriage return at the device connected to the CPB RS-232C port. After the prompt is printed out, the password should be entered followed by a carriage return. Proper entry of the password will result in the maintenance prompt. The Remote Maintenance password is: {BRANDY}

D. Exit Maintenance

The Exit command will terminate the current Remote Maintenance feature session. The Exit command format is: MAINT>X

```
maint>?  
command list:  
d s[nn] - dump system or slot configuration data  
          [nn] specifies an optional slot number parameter  
          no parameter indicates that the entire system will be dumped  
examples:  
          maint>d s      (dumps entire system configuration)  
          maint>d s2    (dumps slot 2 configuration, etc.)  
?  
x      - help menu  
      - exit maint  
maint>
```

Figure 800-1 Remote Maintenance Help Menu

E. System Configuration

Figure 800-2 is a configuration of the Starplus 96EX system with LCR and shows what is printed out when:

a. The installer enters **D<space>S** at the maint> prompt.

```

7S MONITOR Eng. Ver. X.XY
DATE: MM/DD/YY TIME: HH:MM:SS
ENTER PASSWORD:
Maint> s

```

SLOT	TYPE	FW VER.	BRD TYPE	BRD OPTS	SERV STAT
1	CPB		2.0f	96EX,LCR	INS
2	COL	1	COB	0	INS
3	COL	1	COB	0	INS
4	COL	#	UNPOPULATED	0	OOS
5	STA	3	KIB	0	INS
6	STA	#	UNPOPULATED	0	OOS
7	STA	#	UNPOPULATED	0	OOS
8	STA	#	UNPOPULATED	0	OOS
9	STA	1	SIB	0	INS
10	STA	1	SIB	0	INS
11	APB	0	APL	0	INS
12	STA	#	UNPOPULATED	0	OOS
13	STA	#	UNPOPULATED	0	OOS
14	STA	#	UNPOPULATED	0	OOS
15	STA	#	UNPOPULATED	0	OOS
16	STA	#	UNPOPULATED	0	OOS
17	STA	#	UNPOPULATED	0	OOS
18	COL	#	UNPOPULATED	0	OOS
19	COL	#	UNPOPULATED	0	OOS

```

maint>

```

Figure 800-2 Starplus 96EX Configuration with/LCR

where:

Column 1: lists the card slot.

Column 2: lists card type of that card slot.

Column 3: lists the firmware version of the card.

Column 4: lists card type and if that card is installed.

Column 5: lists card options:

KIB option 0 = standard KIB

APL option 0 = standard APL:

APL: option 1 = APL: + RSM

APL: option 2 = APL: + SIU Module

APL: option 3 = APL: + RSM + SIU

Column 6: lists card status:

OOS status can indicate the entire card is out of service or a specific station is not installed or installed but not operational

INS status can indicate a specific station is installed and operating correctly.

F. CO Line Configuration

Figure 800-3 is the CO Line Configuration and shows what is printed out when:

a. The installer enters **D<space>S4** at the maint> prompt.

```

maint>d s4
  SLOTT : 4
  Slot Type : COL
  Board Type: COB
  CO      STATUS      PULSE/DTMF      CO/PBX
  17     INS, Outgoing Enabled      DTMF           CO
  18     INS, Outgoing Enabled      DTMF           CO
  19     INS, Outgoing Enabled      DTMF           CO
  20     INS, Outgoing Enabled      DTMF           CO
  21     INS, Outgoing Enabled      DTMF           CO
  22     INS, Outgoing Enabled      DTMF           CO
  23     INS, Outgoing Enabled      DTMF           CO
  24     INS, Outgoing Enabled      DTMF           CO
maint>

```

Figure 800-3 CO Line Configuration Printout

where:

Column 1: lists the CO Line number.

Column 2: indicates status:

OOS status can indicate the entire card is out of service.

INS status can indicate a board station is installed and operating correctly. Outgoing enabled indicates the CO line is active in the system. Outgoing disabled indicates that the Attendant has disabled the CO line for outgoing access

Column 3: indicates whether the CO Line is Pulse or DTMF. (programmable option)

Column 4: indicates whether the CO Line is a CO Line or a PBX Line. programmable option)

G. Station Configuration

Figure 800-4 is the Station Configuration and shows what is printed out when:

a. The installer enters **D<space>S5** at the maint> prompt.

```

maint>d s5
  SLOT : 5
-----
  Slot Type : STA
  Board Type: KIB
-----
  STA      TYPE      STATUS      LCD
-----
  100     Keyset     INS         Y
  101     DLS         OOS         N
  102     Keyset     INS         Y
  103     Keyset     OOS         N
  104     Basic      INS         N
  105     Keyset     OOS         N
  106     DLS 2     OOS         N
  107     Door Box   INS         N

maint>

```

Figure 800-4 Station Configuration Printout

where:

Column 1: lists the station number.

Column 2: indicates station type (keyset, DSS, SLT, phone box).

Keyset - ID 0 = Key station

DLS - ID 1 = DSS Map 1

DSS - ID 2 = DSS Map 2

DSS/DLS - ID 3 = DSS Map 3

Door Box - ID 4 = Phone Box

SLT - ID 5 = SLT/OPX

SLT w/lamp - ID 6 = SLT w/Message Waiting

Keyset - ID 7 = Basic Keyset

DSS2 - ID 8 = DSS Map 4

DLS2 - ID 9 = DSS Map 5

Column 3: indicates status:

COS status can indicate the entire card is out of service or a specific station is not installed or installed but not operational.

INS status can indicate a specific station is installed and operating correctly.

Column 4: indicates whether the station has an LCD Display or doesn't have an LCD Display.

H. APL Configuration

Figure 800-5 is the APL Configuration shows what is printed out when:

a. The installer enters **D<space>S11** at the **maint>** prompt.

where:

Column 1: identifies the card slot type.

Column 2: shows any options associated with the board plugged into the option card slot.

RS-232 is shown as an option when the RS-232C Module (RSM) is installed on the AP: board.

DTMF is shown as an option when the Single Line DTMFRS unit (SLU) is installed on the AP: board.

```

maint>d s11
  SLOT : 11
-----
  Slot Type : APB
  Board Type: APL

      TYPE                OPTIONS
      -----            -----
      APB                  None

maint>

```

Figure 800-5 APL Configuration Printout

I. Event Trace Buffer

The Event Trace Buffer is used to store and dump event traces (up to 30) that occur just prior to a 96EX system soft or hard restart. These can then be reviewed by authorized personnel to aid in system troubleshooting..

The basic format for the commands are:

- T<space><return> - display the current status of the Event trace buffer
- T<space>0<return> - turns the Trace buffer OFF.
- T<space>1<return> - turns the Trace buffer ON to record events prior to a soft system reset.

- T<space>2<return> - turns the Trace buffer ON to record events prior to a hard system restart.
- T<space>3<return> - turns the Trace Buffer ON to record events prior to either a soft reset or a hard system restart.

d<space>E<return> - dumps Trace Events stored from last system reset. (soft or hard)

NOTE: Ctrl C will abort the Data Dump and return to the maint> prompt.

800.3 REMOTE SYSTEM MONITOR

A. General Overview

The Remote Monitor feature provides remote access to the installed system for diagnostic purposes. These capabilities benefit Service personnel enabling them to support the end user remotely. Different levels of access, via password, allows authorized personnel to trace, monitor and "up-load" critical information directly from the 96EX system. This provides a more accurate means of acquiring system information that leads to a quick resolution of problems that may occur. This is all done without interfering with ongoing call processing or normal system operation, and in many cases may be performed without a site visit. An external modem connected to the CPB RS232-C is required for remote access.

Capabilities allowed and reserved for this "High level troubleshooting" in addition are:

- Monitor Mode
- Enable & Disable Event "Trace"
- Dump "Trace Buffer" (up-load)

B. Monitor Password

The Remote Monitor feature, like Remote Maintenance, is entered via a six-character alphanumeric string. The password prompt is given by entering a carriage return at the device connected to the CPB RS232-C port. After the prompt is printed out, the password should be entered followed by a carriage return. Proper entry of the password will result in the MON>prompt. The Remote Maintenance password is: {JENNIE}

NOTE: The remote monitor feature is intended for use only under the guidance and instruction by authorized personnel from a Technical Assistance Center (TAC). Care and caution must be observed when using this feature as permanent damage to the software structure can occur.

C. Help Menu (?)

A convenient on screen Help Menu is provided by typing a "?" then pressing Enter. The following will appear on the screen:

```

7S MONITOR , Eng. Ver. 2.0d
DATE: 05/13/90 TIME: 11:29:31
ENTER PASSWORD:
mon?
command list:
c [c] - dump co data
s [s] - dump sta data
t [t] - set trace key
d [a][a] - dump memory
m a - modify memory
o rate - set baud rate
? - help menu
x - exit monitor
mon>

```

D. Dump Memory Data

Three options allow the memory structure to be "dumped" for viewing. The three options are entered as follows:

- c [c] - Dump CO Line memory structure
- s [s] - Dump Station memory Structure
- d [a][a] - Dump a memory address Structure

The data obtained from these commands is in hexadecimal format and is used primarily for manufacture level support.

NOTE: Ctrl C will abort the Data Dump and return to the mon> prompt.

E. Event Trace Mode

The "T" command enables and disables the 96EX system Trace mode. While the trace mode is enabled events for the trace desired will be displayed on the monitor, printer or PC connected to the 96EX system in an event record. To view the current status of the trace mode type "T"<return> at the MON> prompt then the following screen will be displayed:

```

mon>t
  Messages  Y/N
  -----  ---
BOARD EVT  -> N
MSC States -> N
PP          -> N
COL States -> N
Stn States -> N
Error Msg  -> N
Que Evt    -> N

mon>
    
```

- A. To enable an event trace type "t" <space> (space bar)
- B. Then type of trace desired [d], where d is determined as follows:
 - B= Board event trace (traces events associated with PCB's)
 - M= Miscellaneous State event trace
 - P= Peripheral Processor (PP) (traces events associated with a Peripheral processor command i.e. COB, KIB, APL: etc...)
 - C= CO Line (COL) States (traces events associated with CO Line activity)
 - S= Station (STA) States (traces events associated with Station activity)
 - E= Error Messages (traces error messages)
 - Q= Queue (QUE) Events (traces queuing events, i.e. DTMF receiver, UCD, LCR, etc...)

C. Then enter the specific board, CO line or Station number of the trace desired or type "all" if all board's, CO line's or Station's events are desired.

- 1-19 = Board KSU card slot position (CPB= 1)
- 01-40 = CO Line port
- 100-195 = Station location
- All= All Boards, CO lines or Stations

D. Then press Enter to enable the trace. A screen similar to the following will appear:

```

mon>t
  Messages  Y/N
  -----  ---
BOARD EVT  -> Y   Trace BRD 4
MSC States -> N
PP          -> N
COL States -> Y   Trace COL 8
Stn States -> Y   Trace ALL
Error Msg  -> N
Que Evt    -> N

mon>
    
```

E. To disable or turn off a particular trace mode do not enter a specific board, CO line or Station number (i.e. "t<space>s<return>" to disable station event trace).

To have event trace's displayed on the screen you must first exit the MONitor mode by typing "X" at the MON> prompt. After you exit the event(s), the trace will begin as shown in Table 800-6.

CAUTION

Unless instructed by personnel at a Technical Assistance Center (TAC) do not leave the trace mode enabled for extended periods of time. The system will "dump" the requested event(s) trace which may use up paper or fill memory buffers on the collecting device. It is recommended that the trace events be disabled (turned off) for all event(s) traces before leaving the system site.

```

Sta 105: State= WAIT_COL_SZ_RSP, Evt= Seize Ack (10), Data=0
Sta 105: State= COL_CONNECTED, Evt= Dial Pad (26), Data=9
Col 08: State= OUTPUTSING, Evt= outpulse_digit, Data=9
Col 08: State= OUTPUTSING, Evt= Digit Sent, Data=0
Sta 105: State= COL_CONNECTED, Evt= Dial Pad (26), Data=9
Col 08: State= OUTPUTSING, Evt= outpulse_digit, Data=9
Col 08: State= OUTPUTSING, Evt= Digit Sent, Data=0
Col 08: State= OUTPUTSING, Evt= Digit Sent, Data=0
Sta 105: State= COL_CONNECTED, Evt= Dial Pad (26), Data=9
Col 08: State= TALK, Evt= outpulse_digit, Data=9
Col 08: State= OUTPUTSING, Evt= Digit Sent, Data=0
Sta 105: State= COL_CONNECTED, Evt= Dial Pad (26), Data=8
Col 08: State= TALK, Evt= outpulse_digit, Data=8
Col 08: State= OUTPUTSING, Evt= Digit Sent, Data=0
Sta 105: State= COL_CONNECTED, Evt= Dial Pad (26), Data=6
Col 08: State= TALK, Evt= outpulse_digit, Data=6
Col 08: State= OUTPUTSING, Evt= Digit Sent, Data=0
Sta 105: State= COL_CONNECTED, Evt= Dial Pad (26), Data=6
Col 08: State= TALK, Evt= outpulse_digit, Data=6
Col 08: State= OUTPUTSING, Evt= Digit Sent, Data=0
Sta 105: State= COL_CONNECTED, Evt= Dial Pad (26), Data=5
Col 08: State= TALK, Evt= outpulse_digit, Data=5
Col 08: State= OUTPUTSING, Evt= Digit Sent, Data=0

```

Figure 800-6 Event Trace as it appears on Display

F. Modify Memory command

The Modify Memory Command is for Engineering Use only.

CAUTION

Use of this command can alter or damage the Starplus 96EX systems operating data base which can result in system malfunction. If this occurs it will be necessary to power the system down and re-initialize the data base, then completely re-program the customer programming data.

G. Baud Rate Command

This command provides a convenient means for changing the baud rate, for the RS232-C port located on the CPB, while in the Monitor mode. To change the baud rate type "B" plus the desired baud rate, then the enter key.

NOTE: After changing the Baud Rate via Baud Rate command, you must change your Baud Rate on your Receiver/Terminal.

H. Exit the Monitor mode

The Exit command will terminate the current Remote Monitor enable/disable session. If Event(s) Trace have been or are still enabled the event records will be displayed only after exiting the MONitor mode. The Exit command format is: MON X

CAUTION

Unless instructed by personnel at a Technical Assistance Center (TAC) do not leave the trace mode enabled for extended periods of time. The system will "dump" the requested event(s) trace which may use up paper or fill memory buffers on the collecting device. It is recommended that the event traces be disabled (turned off) for all event(s) before leaving the system site.

APPENDIX A

CUSTOMER DATABASE PROGRAMMING

Appendix A-1 System Parameters

PROG CODE	FLEX BTN	FUNCTION	FORMAT	DEFAULT	CUSTOMER DATA
FLASH 01		System Hold Recall	000-300 s	060 s	
FLASH 02		Exclusive Hold Recall	000-300 s	180 s	
FLASH 03		Transfer Recall	000-300 s	045 s	
FLASH 04		Preset Forward Timer	00-99 s	10 s	
FLASH 05		Pause Timer	1-9 s	2 s	
FLASH 06		Call Park Timer	000-600 s	180 s	
FLASH 07		Conference Timer	00-99 m	10 m	
FLASH 08		MSG Wait Reminder Tone	000-104 m	000 m	
FLASH 09		Paging Timeout Timer	00-60 s	15 m	
FLASH 10		CO Ring Detect Timer	200-900 msec	300 msec	
FLASH 11	1	Hold Preference	Sys/Excl	System	
FLASH 12		Automatic Privacy	Yes/No	Yes	
FLASH 12		Executive Warning Tone	Yes/No	Yes	
FLASH 13	1	External Night Ring	Yes/No	No	
FLASH 14	1	Attendant Override	Yes/No	No	
FLASH 15		Attendant Assignment	100-195	100	
FLASH 16		Loud Bell Control	Sta #, Sta #	None	
FLASH 17		PBX Dialing Codes	Five 2 digit	None	
FLASH 18	1	Exec/Secy Pair 1	Sta #, Sta #	None	
	2	Exec/Secy Pair 2	Sta #, Sta #	None	
	3	Exec/Secy Pair 3	Sta #, Sta #	None	
	4	Exec/Secy Pair 4	Sta #, Sta #	None	
FLASH 21	1	SMDR	Yes/No	No	
	2	Call Type	All/LD only	LD only	

Appendix A-1 System Parameters (Cont'd)

PROG CODE	FLEX BTN	FUNCTION	FORMAT	DEFAULT	CUSTOMER DATA
FLASH 21	3	Print Columns	80/29	80	
	4	Baud Rate	300/1200/4800	4800	
	5	Account Codes	Yes/No	No	
FLASH 21		Admin. Password	One 4 digit	2366	
FLASH 22	1	Dial Pulse	60/40, 66/33	60/40	
	2	Dialing Speed	10/20 pps	10 pps	
FLASH 23	1	LCR Enable	Yes/No	No	
FLASH 24		DISA Access Code	100-999	100	
FLASH 25		Phone Box Timer	00-60 s	20 s	
FLASH 26	1	Attendant Intercom	Yes/No	Yes	
FLASH 27	1	Background Music	Yes/No	Yes	
FLASH 28		Time/Date Format	12/24 HR:M/D	12 HR:M/D	
FLASH 29		Hookswitch Timer	05-20	10	
FLASH 30		Hookswitch Bounce	000-100	010	
FLASH 31	1	Page Warning Tone	Yes/No	Yes	
FLASH 32		Attendant Recall Timer	00-60	01	
FLASH 35		Call Forward No-Answer	000-600	015	
FLASH 39	1	Night Mode Operation	Auto/Manual	Manual	
	2	ANM Schedule - Monday	Off time	On time	0 /
				0800/1700	
		ANM Schedule - Tuesday	Off time	On time	1 /
				0800/1700	
		ANM Sch - Wednesday	Off time	On time	2 /
				0800/1700	
		ANM Schedule - Thursday	Off time	On time	3 /
				0800/1700	
		ANM Schedule - Friday	Off time	On time	4 /
				0800/1700	
		ANM Schedule - Saturday	Off time	On time	5 /
				#####	
		ANM Schedule - Sunday	Off time	On time	6 /
				#####	
FLASH 41		SLT Receiver Time-out	005-100	020	

Appendix A-2 UCD and Hunt Group Parameters

PROG CODE	FLEX BTN	FUNCTION	ALT	OVR	RAN	STATIONS (up to 8 Stations)
FLASH 19	1	UCD Group 0 (890)				
	2	UCD Group 1 (891)				
	3	UCD Group 2 (892)				
	4	UCD Group 3 (893)				
	5	UCD Group 4 (894)				
	6	UCD Group 5 (895)				
	7	UCD Group 6 (896)				
	8	UCD Group 7 (897)				

PROG CODE	FLEX BTN	FUNCTION	FORMAT	DEFAULT	CUSTOMER DATA
FLASH 33	1	UCD Ring Timer	000-300	060	
	2	UCD Message Timer	000-300	060	
	3	UCD Overflow Timer	000-300	060	
	4	UCD Wrap-up Timer	000-999	004	
FLASH 34		Announcement Table 1	NYXXMMM	None	
		Announcement Table 2	NYXXMMM	None	

PROG CODE	FLEX BTN	FUNCTION	ALT	PILOT or STATION	STATIONS (up to 8 Stations)
FLASH 38	1	Hunt Group 0 (590)			
	2	Hunt Group 1 (591)			
	3	Hunt Group 2 (592)			
	4	Hunt Group 3 (593)			
	5	Hunt Group 4 (594)			
	6	Hunt Group 5 (595)			
	7	Hunt Group 6 (596)			
	8	Hunt Group 7 (597)			

Appendix A-3 Voice Mail Group Parameters

PROG CODE	FLEX BTN	FUNCTION	ALT	L	R	STATIONS (Up to 8 Stations)
FLASH 36	1	Voice Mail Group 0 (690)				
	2	Voice Mail Group 1 (691)				
	3	Voice Mail Group 2 (692)				
	4	Voice Mail Group 3 (693)				
	5	Voice Mail Group 4 (694)				
	6	Voice Mail Group 5 (695)				
	7	Voice Mail Group 6 (696)				
	8	Voice Mail Group 7 (697)				

PROG CODE	FLEX BTN	FUNCTION	OUTPULSING DIGITS	L or R
FLASH 37	1	VM Outpulsing Table 1	Prefix	
			Suffix	
	2	VM Outpulsing Table 2	Prefix	
			Suffix	
	3	VM Outpulsing Table 3	Prefix	
			Suffix	
	4	VM Outpulsing Table 4	Prefix	
			Suffix	
	5	VM Outpulsing Table 5	Prefix	
			Suffix	
	6	VM Outpulsing Table 6	Prefix	
			Suffix	
	7	VM Outpulsing Table 7	Prefix	
			Suffix	
	8	VM Disconnect Table 8	Disconnect	

FLASH 42		Voice Mail ID digits for Incoming CO Calls	Yes or No
----------	--	--	-----------

Appendix A-4 CO Line Programming (Flash 40)

FLEX BTN		1	2	3	4	5	6	7	8	9	13	14	
CO I #1	LINE NO	TONE/ PULSE	CO/ PBX	UNA	LOOP SUPV	DISA	FLASH TIME	LINE GROUP	LINE COS	RING*	CONF Er/Dis	AUTO PRIVACY	REMARKS
		01											
	02												
	03												
	04												
	05												
	06												
	07												
	08												
	09												
	10												
	11												
	12												
	13												
	14												
	15												
	16												
	17												
	18												
	19												
	20												
	21												
	22												
	23												
	24												
DEFAULT		Tone	CO	Yes	No	No	10	1	1		Yes	Yes	

*Refer to CO Line Ringing Assignments

Appendix A-4 CO Line Programming (Flash 40) (Cont'd)

FLEX BTN	1	2	3	4	5	6	7	8	9	13	14	
LINE NO	TONE/ PULSE	CO/ PBX	UNA	LOOP SUPV	DISA	FLASH TIME	LINE GROUP	LINE COS	RING*	CONF Er/Dis	AUTO PRIVACY	REMARKS
C O I #												
C O I #												
C O I #												
DEFAULT	Tone	CO	Yes	No	No	10	1	1		Yes	Yes	

*Refer to CO Line Ringing Assignments

Appendix A-5 CO Line Ringing Assignment Chart

CO LINE	Day Ringing Assignments:	CO LINE	Day Ringing Assignments:
Type	Night Ringing Assignments:	Type	Night Ringing Assignments:
Number		Number	
CO LINE	Day Ringing Assignments:	CO LINE	Day Ringing Assignments:
Type	Night Ringing Assignments:	Type	Night Ringing Assignments:
Number		Number	
CO LINE	Day Ringing Assignments:	CO LINE	Day Ringing Assignments:
Type	Night Ringing Assignments:	Type	Night Ringing Assignments:
Number		Number	
CO LINE	Day Ringing Assignments:	CO LINE	Day Ringing Assignments:
Type	Night Ringing Assignments:	Type	Night Ringing Assignments:
Number		Number	

COI # _____

Button 1 = Enter Ringing Assignments
 Button 2 = Display Ringing Assignments

Ringing Assignments:
 0 = No Ring (Deletes Station from Ringing Assignment)
 1 = D (Day Ringing)
 2 = N (Night Ringing)
 3 = B (Both Day and Night Ringing)

Appendix A-6 Station Programming (Flash 50)

DATA FIELD	Page/ BTN	STATION NUMBER								DEFAULT
PAGE ACCESS	A/1									Yes
DO NOT DISTURB	A/2									Yes
SYSTEM SPEED	A/3									Yes
QUEUING	A/4									Yes
PREFERRED LINE ANSWER	A/5									No
EXECUTIVE OVERRIDE	A/6									No
CALL FWD	A/7									Yes
FORCED LCR	A/8									
LCR COS (0-6)	A/9									0
CONFERENCE Enable/Disable	A/13									Yes
STA ID (0-6)	B/1									0
COS (1-6)	B/2									1
SPEAKERPHONE (0-1)	B/3									0
PICKUP GROUP (0-4)	B/4									1
PAGING ZONE (0-4)	B/5									1
PRESET FORWARD	B/6									None
CO LINE GROUP (0-8)	B/7									1
BUTTON ASSIGN	B/8	See Button Assignment Chart								
AUTOMATIC PRIVACY	B/13									Yes
OFF-HOOK PREFERENCE	B/14									001

KIB # _____ Page A is selected by pressing Button 10 of the flexible buttons.

Page B is selected by pressing Button 11 of the flexible buttons.

Appendix A-7 Button Assignment Chart (Flash 50)

STA # _____ PORT # _____		1	2	3	4
		5	6	7	8
		9	10	11	12
		13	14	15	16
17	18	19	20	21	22

STA # _____ PORT # _____		1	2	3	4
		5	6	7	8
		9	10	11	12
		13	14	15	16
17	18	19	20	21	22

STA # _____ PORT # _____		1	2	3	4
		5	6	7	8
		9	10	11	12
		13	14	15	16
17	18	19	20	21	22

STA # _____ PORT # _____		1	2	3	4
		5	6	7	8
		9	10	11	12
		13	14	15	16
17	18	19	20	21	22

STA # _____ PORT # _____		1	2	3	4
		5	6	7	8
		9	10	11	12
		13	14	15	16
17	18	19	20	21	22

STA # _____ PORT # _____		1	2	3	4
		5	6	7	8
		9	10	11	12
		13	14	15	16
17	18	19	20	21	22

STA # _____ PORT # _____		1	2	3	4
		5	6	7	8
		9	10	11	12
		13	14	15	16
17	18	19	20	21	22

STA # _____ PORT # _____		1	2	3	4
		5	6	7	8
		9	10	11	12
		13	14	15	16
17	18	19	20	21	22

Appendix A-7 Button Assignment Chart (Flash 50) (Cont)

This chart is to be used to assign each flexible button a function. By default, Buttons 1 through 8 are assigned as Stations 100 through 107, Buttons 9 through 14 are assigned as CO Lines 01 through 06, Button 15 is a pooled group button for CO Line group 1, and Button 16 is a loop button.

WHERE:

BB = Button Number (01 through 22)
LL = CO Line Number (01 through 40)
G = Line Group (1 through 7)

1. To assign a button as a multi-function button (user programmable) enter:
BB [0] HOLD
2. To assign a button as a CO Line button, enter:
BB [1] LL HOLD
3. To assign a button as a loop button, enter:
BB [2] HOLD
4. To enter a button as a pooled group button (refer to Section 600.47 for CO Line Group numbers) enter:
BB [3] G HOLD
5. To unassign a button, rendering it inoperable, enter:
BB [#] HOLD
6. When an SLT is being assigned for Off-Hook Preference, enter:
00 [1] LL HOLD for a specific CO Line
or
00[3] G HOLD for CO Group Access.

Appendix A-8 System Speed Dial Numbers

Programmed from the first Attendant station.

Monitored by Toll Restriction (COS)

BIN #	Telephone Number
20	
21	
22	
23	
24	
25	
26	
27	
28	
29	
30	
31	
32	
33	
34	
35	
36	
37	
38	
39	

BIN #	Telephone Number
40	
41	
42	
43	
44	
45	
46	
47	
48	
49	
50	
51	
52	
53	
54	
55	
56	
57	
58	
59	

Appendix A-8 System Speed Dial (Cont'd)

Programmed from the first Attendant station.

Overrides Toll Restriction (COS)

BIN #	Telephone Number
60	
61	
62	
63	
64	
65	
66	
67	
68	
69	
70	
71	
72	
73	
74	
75	
76	
77	
78	
79	

BIN #	Telephone Number
80	
81	
82	
83	
84	
85	
86	
87	
88	
89	
90	
91	
92	
93	
94	
95	
96	
97	
98	
99	

Appendix A-9 Exception Tables (Flash 60)

Allow Table A

BIN 1	
BIN 2	
BIN 3	
BIN 4	
BIN 5	
BIN 6	
BIN 7	
BIN 8	
BIN 9	
BIN 10	
BIN 11	
BIN 12	
BIN 13	
BIN 14	
BIN 15	
BIN 16	
BIN 17	
BIN 18	
BIN 19	
BIN 20	

Allow Table B

BIN 1	
BIN 2	
BIN 3	
BIN 4	
BIN 5	
BIN 6	
BIN 7	
BIN 8	
BIN 9	
BIN 10	
BIN 11	
BIN 12	
BIN 13	
BIN 14	
BIN 15	
BIN 16	
BIN 17	
BIN 18	
BIN 19	
BIN 20	

Deny Table A

BIN 1	
BIN 2	
BIN 3	
BIN 4	
BIN 5	
BIN 6	
BIN 7	
BIN 8	
BIN 9	
BIN 10	

Deny Table B

BIN 1	
BIN 2	
BIN 3	
BIN 4	
BIN 5	
BIN 6	
BIN 7	
BIN 8	
BIN 9	
BIN 10	

Appendix A-10 Least Cost Routing (Flash 61)

CO LINE GROUPS (FLASH 30)

1	2	3	4	5	6	7

Enter what type lines are programmed in each group.

DAILY START TIME TABLE		
START TIME	DEFAULT TIME	CHANGED TIME
1	0800	
2	1700	
3	2300	
4	####	

WEEKLY SCHEDULE TABLE							
START TIME (From Daily Start Table)	TIME PERIOD ROUTE LIST						
	MON	TUE	WED	THU	FRI	SAT	SUN
1							
2							
3							
4							

TOLL INFORMATION ROUTE LIST TABLE	DEFAULT 00	
-----------------------------------	---------------	--

Appendix A-11 Route List Table

Route	Time	1st Group	Insert/ Delete	PRI/O	2nd Group	Insert/ Delete	PRI/O	3rd Group	Insert/ Delete	PRI/O	4th Group	Insert/ Delete	PRI/O	5th Group	Insert/ Delete	PRI/O	6th Group	Insert/ Delete	PRI/O	7th Group	Insert/ Delete	PRI/O		
00	1																							
	2																							
	3																							
	4																							
01	1																							
	2																							
	3																							
	4																							
02	1																							
	2																							
	3																							
	4																							
03	1																							
	2																							
	3																							
	4																							

Appendix A-11 Route List Table (Cont'd)

Route	Time	1st Group	Insert/ Delete	PRIO	2nd Group	Insert/ Delete	PRIO	3rd Group	Insert/ Delete	PRIO	4th Group	Insert/ Delete	PRIO	5th Group	Insert/ Delete	PRIO	6th Group	Insert/ Delete	PRIO	7th Group	Insert/ Delete	PRIO	
04	1																						
	2																						
	3																						
	4																						
05	1																						
	2																						
	3																						
	4																						
06	1																						
	2																						
	3																						
	4																						
07	1																						
	2																						
	3																						
	4																						

Appendix A-11 Route List Table (Cont'd)

Route	Time	1st Group	Insert/ Delete	PRIO	2nd Group	Insert/ Delete	PRIO	3rd Group	Insert/ Delete	PRIO	4th Group	Insert/ Delete	PRIO	5th Group	Insert/ Delete	PRIO	6th Group	Insert/ Delete	PRIO	7th Group	Insert/ Delete	PRIO		
08	1																							
	2																							
	3																							
	4																							
09	1																							
	2																							
	3																							
	4																							
10	1																							
	2																							
	3																							
	4																							
11	1																							
	2																							
	3																							
	4																							

Appendix A-11 Route List Table (Cont'd)

Route	Time	1st Group	Insert/ Delete	PRIO	2nd Group	Insert/ Delete	PRIO	3rd Group	Insert/ Delete	PRIO	4th Group	Insert/ Delete	PRIO	5th Group	Insert/ Delete	PRIO	6th Group	Insert/ Delete	PRIO	7th Group	Insert/ Delete	PRIO	
12	1																						
	2																						
	3																						
	4																						
13	1																						
	2																						
	3																						
	4																						
14	1																						
	2																						
	3																						
	4																						
15	1																						
	2																						
	3																						
	4																						

Appendix A-12 Insert/Delete Tables

TABLE	DIGITS DIALED	
00	INSERT	PRE
		POST
01	DELETE	(PRE)
02	INSERT	PRE
		POST
03	DELETE	(PRE)
04	INSERT	PRE
		POST
05	DELETE	(PRE)
06	INSERT	PRE
		POST
07	DELETE	(PRE)
08	INSERT	PRE
		POST
09	DELETE	(PRE)
10	INSERT	PRE
		POST
11	DELETE	(PRE)
12	INSERT	PRE
		POST
	DELETE	(PRE)

Appendix A-12 Insert/Delete Tables (Cont'd)

TABLE	DIGITS DIALED	
13	INSERT	PRE
		POST
	DELETE	(PRE)
14	INSERT	PRE
		POST
	DELETE	(PRE)
15	INSERT	PRE
		POST
	DELETE	(PRE)
16	INSERT	PRE
		POST
	DELETE	(PRE)
17	INSERT	PRE
		POST
	DELETE	(PRE)
18	INSERT	PRE
		POST
	DELETE	(PRE)
19	INSERT	PRE
		POST
	DELETE	(PRE)

APPENDIX B

STARPLUS 96EX PART NUMBERS

Appendix B-1 Starplus 96EX Component List

<u>Description</u>	<u>Part No.</u>
96EX Basic Key Service Unit (KSU)	SP4000-00
96EX Central Processor Board (CPB)	SP4030-00
DC/DC Converter (DC/DC)	SP4074-00
Key Station Interface Board (KIB)	SP4032-00
Central Office Interface Board (COB)	SP4031-00
Amplified Central Office Board (COA)	SP4031-00
Power Supply Unit (PS)	SP571-00
External Power Supply Housing 2 (EPH2)	SP4070-00
Basic Key Telephone	SP61610-XX
Enhanced Key Telephone	SP61612-00
Executive Key Telephone	SP61614-XX
Expansion Key Service Unit (EKSU)	SP4002-00
Direct Station/Line Selector (DSS/DLS)	SP2410-XX
Phone Box	SP61616-44
RS232C Module (RSM)	SP2437-00
Battery Charging Card (BC)	SP2472-00
Power Failure Transfer Unit (PFT)	SP2436-00
Applications Board (APL)	SP4035-00
Off-Premise Extension Board (OPX)	SP4033-10
Single Line Telephone Interface Board (SIB)	SP4033-00
Single Line Ring Generator (RG)	SP2473-00
Single Line DTMFRS Unit (SLU)	SP2434-00
96EX Desc, Install, and Oper Manual	SP4050-00
96EX Station Users Guide	SP4052-00
96EX Attendant Users Guide	SP4053-00
96EX SLT Users Guide	SP4054-00
ACT Ran Connector Cable	
AEC Messenger 212 Plus Ran Device	
SP Wall Mount Kit	SP61640-XX
SP Replacement Handset	SP61660-XX
SP Replacement 25 ft Handset Cord	P14108-XX
SP Replacement 12 ft Handset Cord	SP61666-XX
SP Blank Designation Tabs	SP61664-00
SP Button Caps	SP61662-00
SP Directory Window for Basic Key	SP61668-00
96EX DSS/DLS Numbered Designation Tabs	SP4062-00

APPENDIX C

AEC The Messenger™ 212 Plus

Description

AEC's The Messenger 212 Plus, Dual-Line Announcer can be used to provide the Recorded Announcement feature of the 96EX Uniform Call Distribution feature (UCD) that provides unanswered incoming CO Calls or calls in queue with a recorded message while waiting for an available UCD station.

The 96EX system provides a programmable option that allows the use of the APL RAN port, unused CO line positions, or SIB ports as the specified RAN output port(s). Each UCD group may be programmed to connect a waiting caller to either the first or second RAN port for the initial message, then select the other RAN port, if connected, for the second and subsequent messages.

Installation

The Messenger 212 Plus can be connected to the 96EX in the following configurations.

- One or Two SIB ports.
- One or Two CO line ports.
- The ABL RAN port and if needed one CO line port.

The connection of each type of port requires different installation practices and will be described separately.

SLT Ports

To install the 212 Plus using one or two SLT ports the following 96EX equipment is required and must be installed for proper operation.

- An SIB board with available ports. (SP4033-00)
- One APL Board. (SP4035-00)
- One RG/MW power supply (SP2473-00)
- One or two modular jacks (4 or 6 pin).

When connecting the Messenger 212 Plus using one or two SIB SLT ports the following options on the 212 Plus unit must be set;

1. Set the switches on the back of the unit as follows;

S1 - off
S2 - off
S3 - off
S4 - off

2. The internal jumper plug of the Messenger 212 Plus should be in its default line type setting of CO/PBX. This will match the SLT port(s) of the 96EX system and provide ring trip for the start of the message.

NOTE: When the jumper plug of the Messenger 212 Plus is set to CO/PBX for the line type then both lines of the Messenger must be connected to SLT ports of the 96EX system.

3. Connect the Voice Tip and Voice Ring from the "J" connector of the SLT port being used to a modular jack. Using the line cords provided plug in to the modular jack and one of the Line jacks in the back of the Messenger 212 Plus unit. (See figure 1)

APL RAN and CO Line Ports

For connection of the Messenger to either the APB RAN Port or to a CO line Port the Messenger 212 Plus must be configured as follows.

1. Set the switches on the back of the Messenger 212 Plus unit as follows;

S1 - off
S2 - off
S3 - off
S4 - on

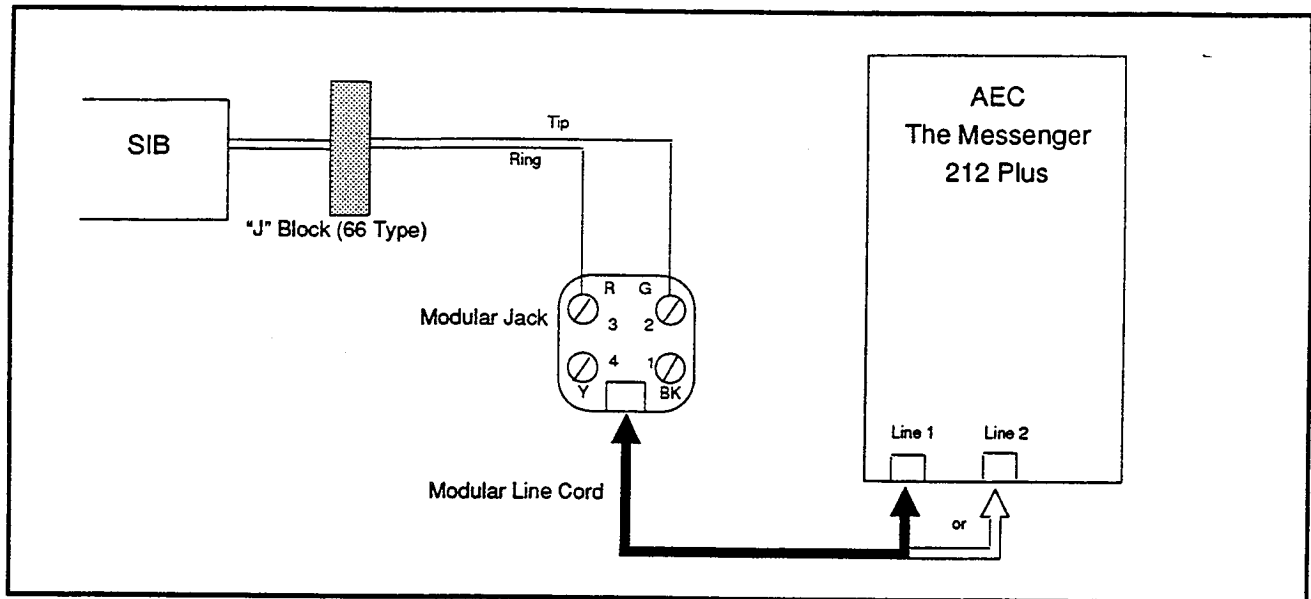

Figure C-1 SLT to AEC Connections

- The internal jumper plug of the Messenger 212 Plus unit should be set to the first alternative setting for a 600 ohm transformer coupled audio output. Check the Messenger 212 Plus Owners Manual for procedures on changing the internal jumper plug.

NOTE: Using the 600 ohm setting of the Messenger 212 Plus both lines of the Messenger must be connected to any combination of the APB RAN output port or one or two CO line port(s).

When installing the Messenger 212 Plus unit onto the 96EX System, both the APB RAN output port and a CO Line port can be used simultaneously. However connection of the Messenger to these ports is different. For this reason each type of installation will be described separately.

ABL RAN Port

When the Messenger 212 Plus unit is installed using the APL RAN port the following equipment will be required.

- An APL Board (SP404035-00)
 - An ACT 8 position to 6 position modular line cord. (98ACT462)
- To connect the Messenger 212 Plus to the APB RAN jack plug the 6 position end of the ACT modular line cord into the APL RAN Port (APL MOD 3 jack) then plug the 8 position end of the line cord into the line 1 or line 2

position on the back of the Messenger 212 Plus unit.

If an ACT 8 position to 6 position cord is not available use the wiring diagram in figure 2 as a guide to connect the Messenger 212 Plus unit to the APL RAN port.

CO Line as a RAN Port

To Install the Messenger 212 Plus using a CO Line port as the RAN output port the following equipment is necessary for a proper installation.

- Unused CO line ports on a COB or COA Board. (SP4031-00 or SP4031-10)
- Power Fail Transfer unit (SP2436-00) with Loud Bell Control for each CO port to be used.
- 24 volt DC power supply to provide a filtered talk path (less than 1 amp is required).
- Two (2) 300 ohm 1/4 watt resistors for each circuit.
- One or two 8 conductor modular jacks and 8 conductor line cords.

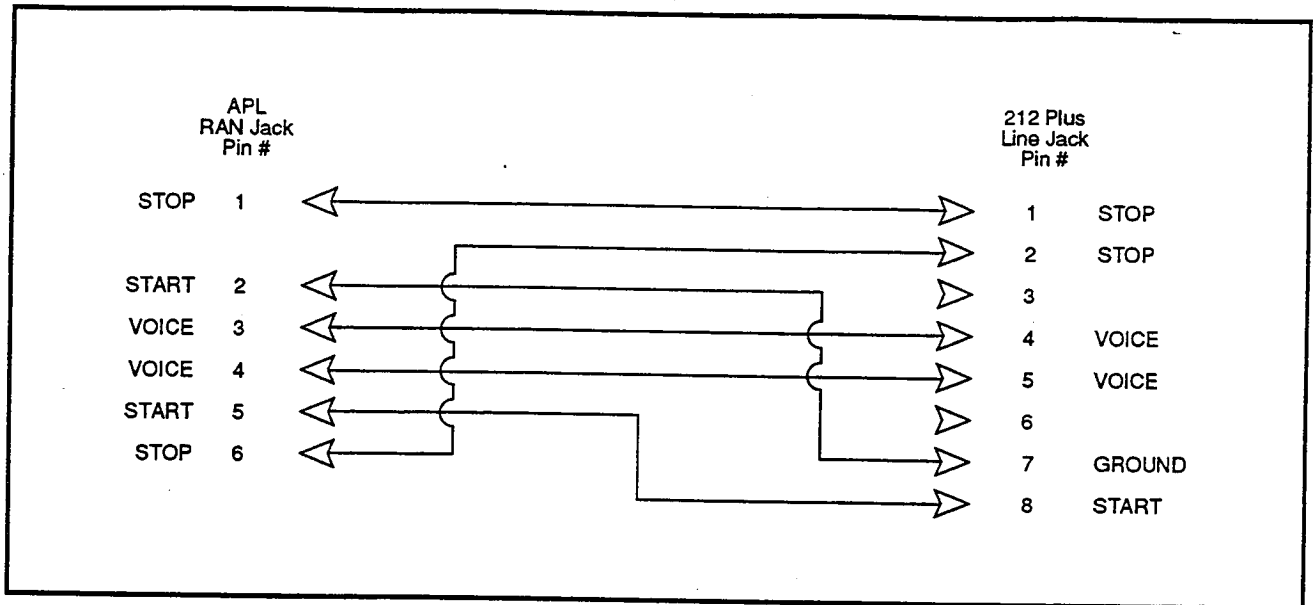

Figure C-2 ACT 8 Cond. to 6 Cond. RAN Line Cord

To install the Messenger 212 Plus using a CO circuit as the interface connect as described below. (see figure 3)

1. Connect the 300 ohm resistor in series with the - (negative) lead of the 24 volt DC power supply and the CO tip on the "P" connector.
2. Next connect the second 300 ohm resistor in series to the + (positive) lead of the power supply and the 8 position modular connector pin 5 (Tip / green).
3. Then wire the ring lead from the "P" connector of the CO port being used to pin 4 of the 8 pin modular jack (Ring / red).
4. Connect both of the LBC contact leads of the Power Fail Transfer unit to the START and GROUND leads of the 8 pin modular jack (pins 7 and 8).

Connection of the Messenger 212 Plus to the 96EX system is now complete. Proceed with applying power and recording your message(s) as described in the Messenger 212 Plus Owners manual.

Programming

It will be necessary to update the data base of the 96EX system to include the RAN options. Depending on the application the following program codes will need to be updated.

- a Universal Call Distribution (FLASH 19) It is necessary to specify which RAN table(s) will be used for each UCD group assigned. This is done by pressing button 12 while in UCD programming.
- b UCD Timers (FLASH 33) The Ring timer (button 1) determines how long an Incoming CO call will ring into the UCD group before being answered and presented to the first message.
 - The Message Interval Timer (MIT)(button 2) determines the duration of time the caller will be in queue and on hold between messages
 - The OVeRflow timer (button 3) determines the total time, starting from when the call was answered, a caller will be kept in queue before being routed to the overflow station.
- c Announcement Tables (FLASH 34) This determines the type, index (port) number and length for the two available Recorded announcements (RAN).

When defining SLT port(s) or CO Line port(s) as the RAN output port it is most important to set the TIME parameter (length of the message) in the Announcement Table so that it is approximately one second longer than the actual message.

- d When a CO line has been used it will be necessary to program an LBC contact to that particular line. This is accomplished in Loud Bell Control assignments (FLASH 16). Assign the CO port to be used for the RAN operation to one of the LBC contacts.

Refer to the Starplus 96EX Description, Installation and Operation manual for further instructions on how to enter the program mode and additional information on the above listed program options. Also reference The Messenger Owner's Manual for recording, battery operation and troubleshooting information.

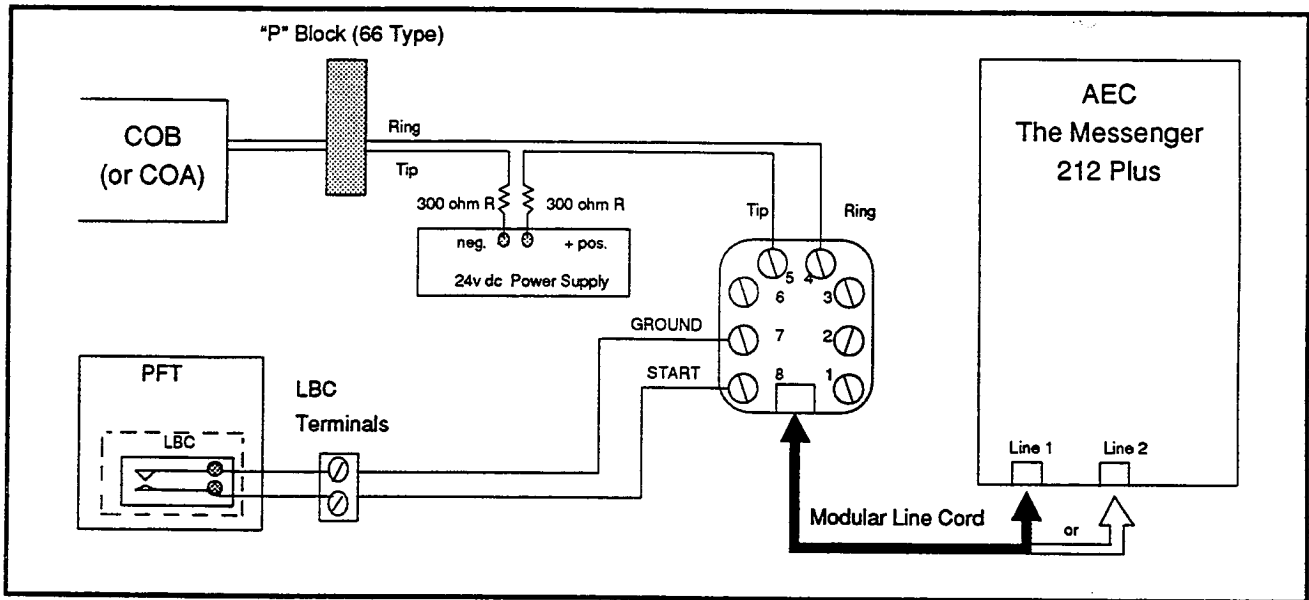

Figure C-3 COB to AEC Connections