



273 Branchport Avenue
 Long Branch, N.J. 07740
 (800) 631-2148
 www.wheelockinc.com

Thank you for using our products.

**INSTALLATION INSTRUCTIONS
 ADDRESSABLE PAGING SPLITTER
 (FOR SP40/2, SPB-160, SPB-80/4, and SPB-320)**

Use this product according to this instruction manual. Please keep this instruction manual for future reference.

MODEL NUMBER:

109920 SP4-APS

1.0 GENERAL:

The Addressable Paging Splitter module (SP4-APS) is designed to be used with Wheelock’s SP40/2 SAFEPATH4 panel and the SP4-TZC Zone Controller. The SP4-APS can also be mounted in SAFEPATH4 Audio Booster (SPB-160, SPB-80/4, and SPB-320) panels. The SP4-APS provides a means for expanding one supervised audio output zone to four Class B or two Class A supervised zones. The SP4-APS also provides two expansion outputs that can be used to add additional audio booster modules in Class A or B configuration. **The SP4-APS is UL Listed under Standard 864**, Control Units for Fire Protective Signaling Systems. It is for indoor use only.

One SP4-APS can be mounted inside the SP40/2 panel. The use of the Splitter Mounting Bracket (SPMB4Z) is required when mounting the SP4-APS splitter(s) inside the Audio Booster panels.

The Addressable Paging Splitter module (SP4-APS) is also used to expand and distribute supervised telephone paging and background music to selected zones when the SAFEPATH4 system is not in the alarm condition. When the SAFEPATH4 system is in the alarm condition all telephone paging and background music inputs are silenced and the emergency message is broadcast on all zones. The SP4-APS is used with the Telephone Zone Controller (SP4-TZC) and controls the distribution of the telephone paging and background music functions.

NOTE: Use of the Telephone Zone Controller (SP4-TZC) is supplementary.

The SP4-APS contains 16 LED indicators used to monitor and troubleshoot the module.

Refer to the Installation Instructions for the Telephone Zone Controller (SP4-TZC) P84567 when connecting the SP4-APS modules for telephone paging and background music operation.

NOTE: All **CAUTIONS** and **WARNINGS** are identified by the symbol . All warnings are printed in bold capital letters.

 WARNING: PLEASE READ THESE INSTRUCTIONS CAREFULLY BEFORE USING THIS PRODUCT. FAILURE TO COMPLY WITH ANY OF THE FOLLOWING INSTRUCTIONS, CAUTIONS AND WARNINGS COULD RESULT IN IMPROPER APPLICATION, INSTALLATION AND/OR OPERATION OF THESE PRODUCTS IN AN EMERGENCY SITUATION, WHICH COULD RESULT IN PROPERTY DAMAGE AND SERIOUS INJURY OR DEATH TO YOU AND/OR OTHERS.

2.0 SPECIFICATIONS:

The SP4-APS has a maximum power output per zone that cannot exceed what is listed in Table 1.

<i>Table 1: SP4-APS Specifications</i>			
Rated Voltage	Rated Current	Audio Input Voltage	Max Power Per Zone
24VDC	0.120A	25VRMS	40W
		70.7VRMS	40W

The total audio power output from all zones on the SP4-APS cannot exceed the audio input power.

Copyright 2005 Wheelock, Inc. All rights reserved.

2.1 WIRING SPECIFICATIONS:

Cable Size: All terminal blocks accept #12 - #18 American Wire Gauge (AWG) for single wire connection.

3.0 WIRING INSTRUCTIONS:

NOTE: The terminal blocks on the SP4-APS are removable. To remove a terminal block, pull the block straight up from the circuit board as shown in Figure 1. Attach wires to the desired connections, then plug the terminal block back on the board being careful to match and align the pins.

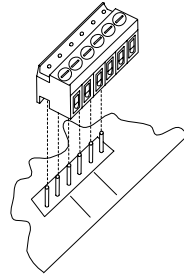

Figure 1: Removable Terminal Block

Figure 2 shows the PC board layout with the locations of all terminal blocks.

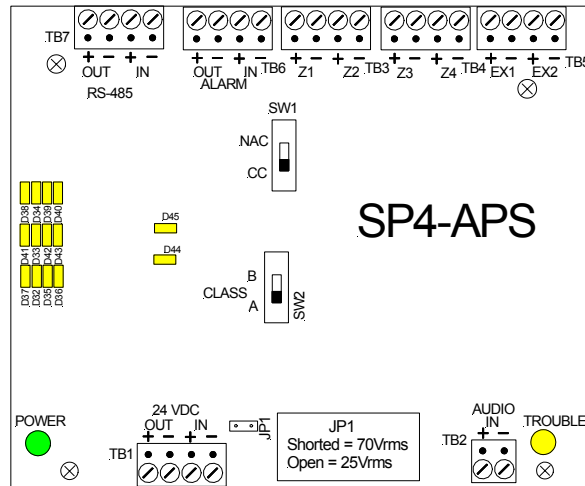

Figure 2: SP4-APS PC Board

Terminals for the RS-485 connections are used with the SP4-TZC and are explained in the SP4-TZC installation instructions.

3.1 Audio Zone Output Wiring

The SP4-APS can be configured for either “CLASS A” or “CLASS B”. It cannot do both at the same time. The maximum audio power output on any zone is 40 watts. Expansion (EX1, EX2) terminals follow the Class A or B setting that applies to all zones.

Instead of speakers, up to four SPB-160 or SPB-80/4 (or two SPB-320) Audio Boosters may be connected to an audio output zone, provided that nothing else is on that zone. The total number of Audio Boosters combined shall not exceed 33.

NOTE: Factory setting is for Class B Wiring.

3.1.1 “CLASS A” Audio Wiring:

When an installation requires “CLASS A” audio field wiring on the SP4-APS module, the Class Selector Switch (SW2) must be set for “CLASS A”. **Note that no end-of-line resistors (UL Listed 10K Ohm, EOLR) are used on any of the SP4-APS module audio output zones as shown in Figure 3.** Zones Z1 and Z2 are connected in Class A configuration as well as Z3 and Z4. Figure 3 shows the SP4-APS with SW2 and the audio field wiring set for “CLASS A”.

The audio zone outputs are either 25Vrms or 70.7Vrms matching the audio input voltage. Remember, the SP40/2 has a maximum audio output to the splitter of 40 watts, while the Audio Boosters have a maximum audio output to the splitter of 80 watts.

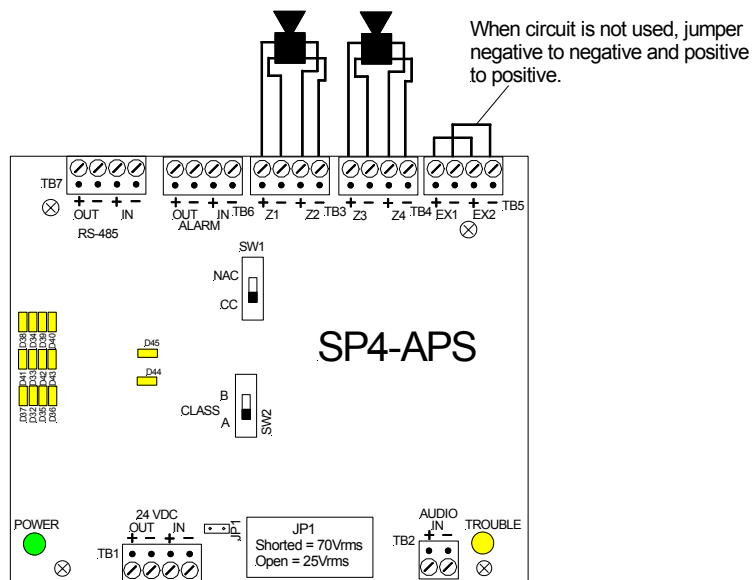

Figure 3: “CLASS A” Zone Connections

Any unused “CLASS A” zone must be jumpered negative to negative and positive to positive. If the Expansion (EX1, EX2) terminals are not used, jumpers **are required**. See Figure 3.

3.1.2 “CLASS B” Audio Wiring:

When an installation requires “CLASS B” audio field wiring, the Addressable Paging Splitter module’s Class Selector Switch (SW2) must be set for “CLASS B.” **Note that end-of-line resistors (UL Listed 10K Ohm, EOLR) are required at the end of each audio output zone even if no speakers are present on a zone.** End-of-line resistors **are required** on the EX1 and EX2 connections whether they are used or not. Figure 4 shows the SP4-APS set for CLASS B audio field wiring:

The audio zone outputs are either 25Vrms or 70.7Vrms matching the audio input voltage. Remember, the SP40/2 has a maximum audio output to the splitter of 40 watts, while the Audio Boosters have a maximum audio output to the SP4-APS of 80 watts.

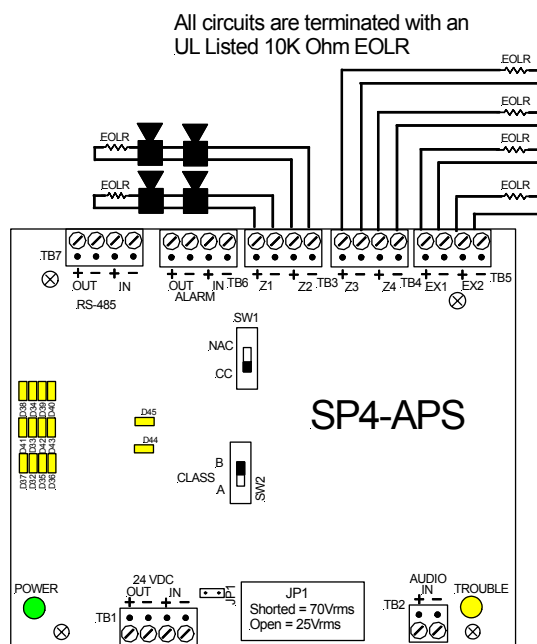

Figure 4: “CLASS B” Zone Connections

3.2 Other Wiring

3.2.1 Expansion Circuit Wiring

The Expansion Circuits (EX1, EX2) are used to link additional audio booster panels (SPB-160, SPB-80/4, and SPB-320) through the SP4-APS. The audio zone outputs are either 25Vrms or 70.7Vrms matching the audio input voltage. EX1 and EX2 are current limited outputs. If an over current condition is detected, the affected Expansion Zone(s) will disable their audio output. When the over current condition has been cleared and the affected Expansion Zone(s) go back to “Normal” condition, the audio output will be re-enabled. **To ensure that current limiting works properly, for 25Vrms JP1 must be open, for 70Vrms JP1 must be closed.** SPB-160 and SPB-80/4 enclosures contain one audio booster module, while the SPB-320 contains two. The SP40/2 has a maximum audio output to the splitter of 40 watts, while the Audio Boosters have a maximum audio output to the splitter of 80 watts. Each audio booster module connected to the expansion circuits uses 1.2 watts. There is a limit of 33 Audio Boosters that can be connected to an SP40/2 using SPB-160 or SPB-80/4 models. Each SPB-320 counts as two SPB-160 models.

The wiring of EX1 and EX2 for “CLASS A” or “CLASS B” is determined by the wiring of the zone outputs and switch SW2 setting. If SW2 is set for “CLASS A”, then all zone outputs and expansion outputs must be wired for “CLASS A”. When using the SP4-APS in “CLASS B” configuration, end-of-line resistors (UL Listed 10K Ohm, EOLR) must be used at the end of each expansion circuit.

3.2.2 24VDC Wiring

The SP4-APS requires 24VDC input in order to operate. Wire the 24VDC from +/- 24VDC connections on the SP40/2 or the DC OUT connections on the applicable audio booster to the +/- 24VDC IN connections on the splitter. If two SP4-APS are used on an SPB-160 or two are used with each SPB-160 in the SPB-320 audio booster enclosure, wire the 24VDC OUT connections on the first SP4-APS to the +/- 24VDC IN connection on the second splitter. Observe correct polarity. See Figure 5 for connection locations.

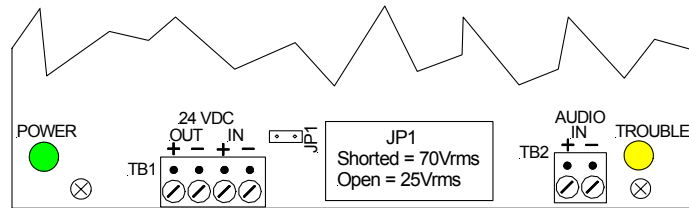

Figure 5: 24VDC Connections

3.2.3 AUDIO IN wiring

The SP4-APS AUDIO IN uses the Audio Out from the SP40/2 or an audio booster, which is either 25Vrms or 70.7Vrms. The total audio output from all zones on the SP4-APS must not exceed its audio input power. See Table 2. See Figure 2 for the location of the AUDIO IN. The SP4-APS uses 8 watts of audio power to operate (1.35 watts per zone.)

SafePath4 Product	Max number of SP4-APS	Requires SPMB4Z (Purchased Separately)	Max Audio Power for Each SP4-APS
SP40/2	1	No	40W
SPB-80/4	1	Yes (1)	80W
SPB-160	2	Yes (1)	80W
SPB-320	4	Yes (2)	80W

4.0 USING THE SP4-APS WITH THE SP40/2

One SP4-APS can be connected to the SP40/2 panel. It is to be mounted inside the panel enclosure onto the backplane in the upper right hand corner.

4.1 MOUNTING INSTRUCTIONS:(SP40/2)

Figure 6 shows the mounting location of the SP4-APS Splitter to the backplane of the SP40/2 panel. Figure 7 shows the correct mounting procedure.

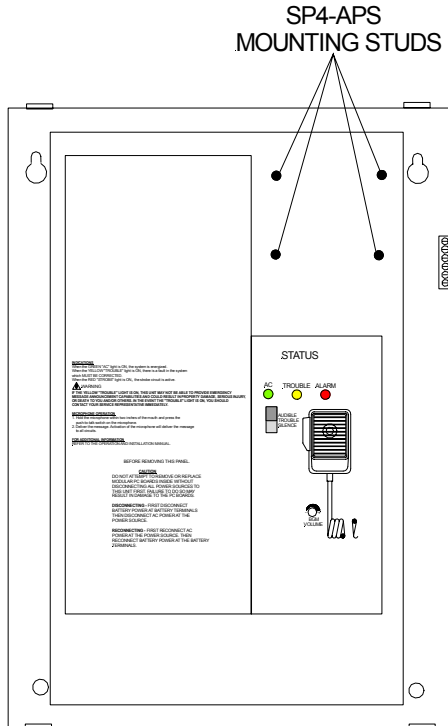

Figure 6:
SP4-APS Mounting Location in SP40/2 Enclosure

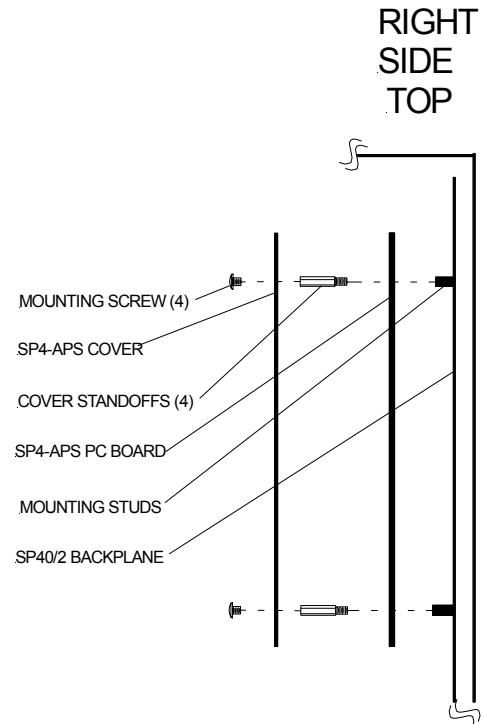

Figure 7:
SP4-APS Mounting in SP40/2 Enclosure

1. Position the SP4-APS PC board so that the side with most of the terminal blocks are pointing to the top of the SP40/2 enclosure and the writing on the PC board can be read. Align the mounting holes on the SP4-APS PC board with the backplane mounting studs.
2. Using the supplied screws, studs, and standoffs, screw the male end of the 4 cover standoffs through the SP4-APS PC board and to the 4 mounting studs on the SP40/2 backplane. Tighten all standoffs snug plus 1/4 turn.
3. Attach wiring in accordance with this section and Figure 7.
4. Align the SP4-APS cover with the holes in the cover standoffs and mount the cover using the 4 mounting screws. Tighten the screws hand tight.

The CC (Contact Closure) Mode Wiring is used when the SP40/2 and Audio boosters are used or when a single SP40/2 is used with one SP4-APS. The Alarm In and Out terminals on the SP4-APS are supervised. **If multiple splitters are used, ONLY the SP4-APS connected to the SP40/2 is configured for CC Multi-mode.**

Figure 8 shows an SP4-APS Splitter set for CC Mode and installed with the SP40/2. Figure 8 also shows the proper separation of Power Limited and Non-Power Limited wiring for the SP40/2.

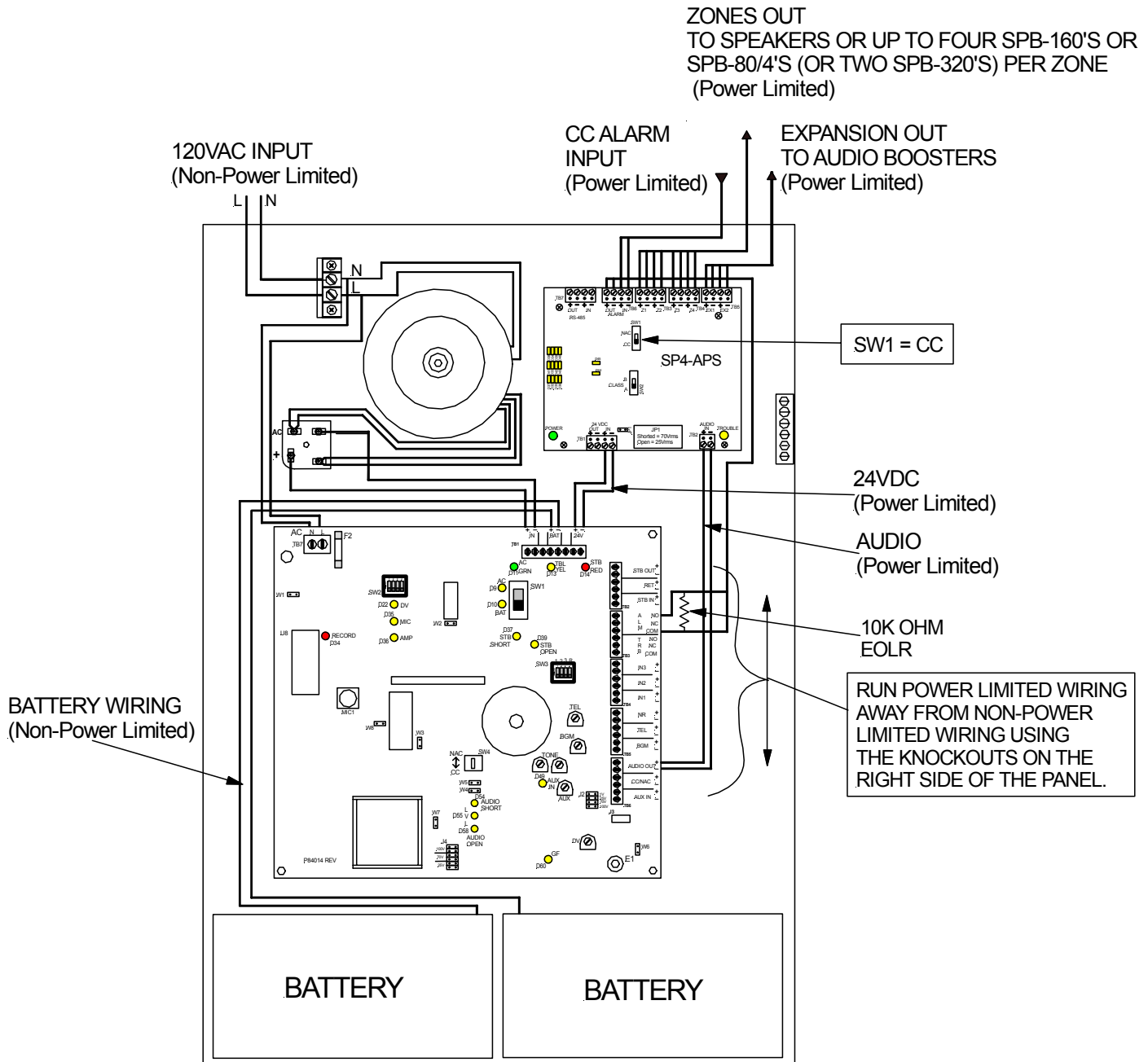

Figure 8:
Power Limited Wiring Diagram
For Connecting The SP4-APS To The SP40/2.

Refer to the SP4-TZC Installation manual for wiring multiple SP4-APS modules together for telephone paging and background music.

4.3 SP40/2 OPERATION

Refer to the SP40/2 Installation, Operation, Maintenance, and Troubleshooting Manual for proper operation instructions of the panel.

5.0 USING THE SP4-APS WITH THE AUDIO BOOSTER (SPB-80/4, SPB-160 and SPB-320)

5.1 MOUNTING INSTRUCTIONS: (SPB-80/4 and SPB-160)

The SP4-APS modules are mounted inside the SPB-80/4 and the SPB-160 enclosures using the Splitter Mounting Bracket (SPMB-4Z - purchased separately).

The Splitter Mounting Bracket can be used to mount two SP4-APS modules to the SPB-160 audio booster and one to the SPB-80/4. The bracket is to be mounted over the 24VDC Power Supply. Figure 9 shows the mounting location of the SP4-APS Splitter to the Splitter Mounting Bracket (SPMB4Z).

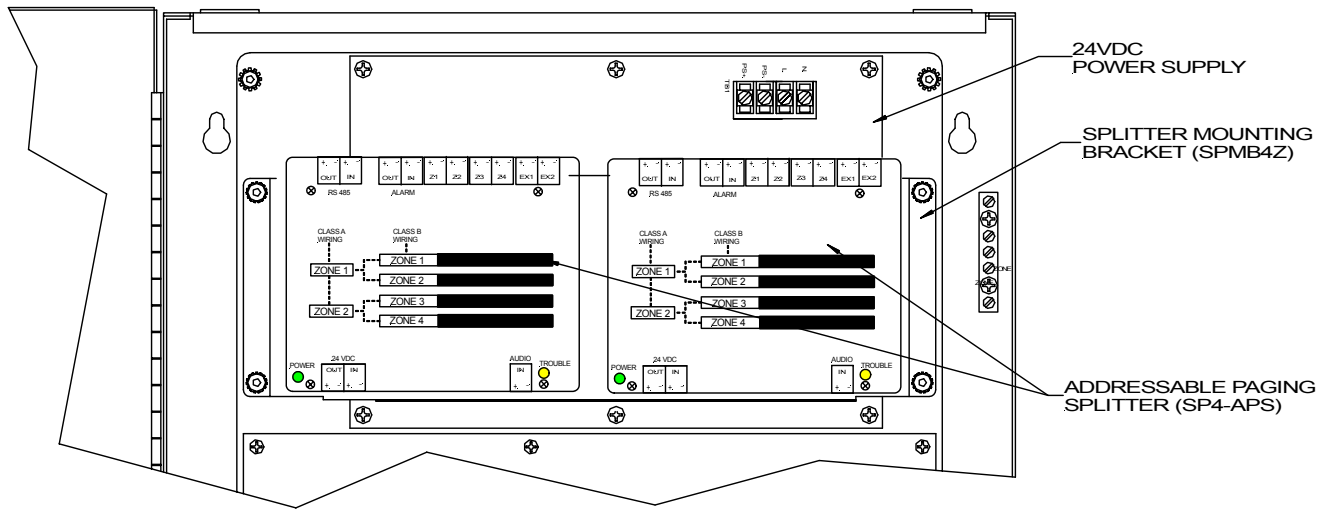

Figure 9:
SP4-APS Mounting Location for the SPB-80/4 and SPB-160

Figure 10 shows the correct mounting location.

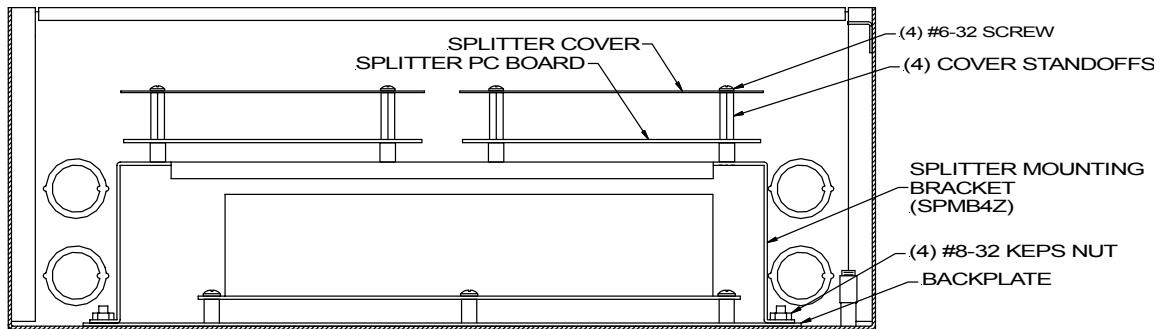

Figure 10:
Mounting Diagram for the SP4-APS Splitter and SPMB-4Z Mounting Bracket

1. Mount the Splitter Mounting Bracket (SPMB4Z) to the SPB-160 or SPB-80/4 according to the SPMB4Z installation instructions (P84252).
2. Position the SP4-APS PC board with the main terminal blocks pointing to the top of the Audio Booster enclosure. Align the mounting holes on the PC board with the mounting studs.
3. Screw the male end of the 4 cover standoffs through the SP4-APS PC board and to the 4 Locking Female Spacers on the SPMB-4Z. Tighten standoffs snug plus 1/4 turn.
4. Attach wiring and set switches in accordance with this installation instruction and the defined configuration.
5. Align the SP4-APS cover with the holes in the cover spacers and mount the cover using the 4 mounting screws. Tighten the screws hand tight.
6. Repeat Steps 2 through 5 when installing second splitter in the SPB-160 Audio Booster.

NOTE: One SPMB-4Z mounting bracket can support two SP4-APS splitters.

5.2 SPB 80/4 AND SPB-160 WIRING

Figure 11 shows the correct wiring of the splitter to the SPB-160. Wiring a single splitter to the SPB-80/4 uses the same procedure.

Figure 11 also shows the proper separation of Power Limited and Non-Power Limited wiring for the SPB-160 and SPB-80.

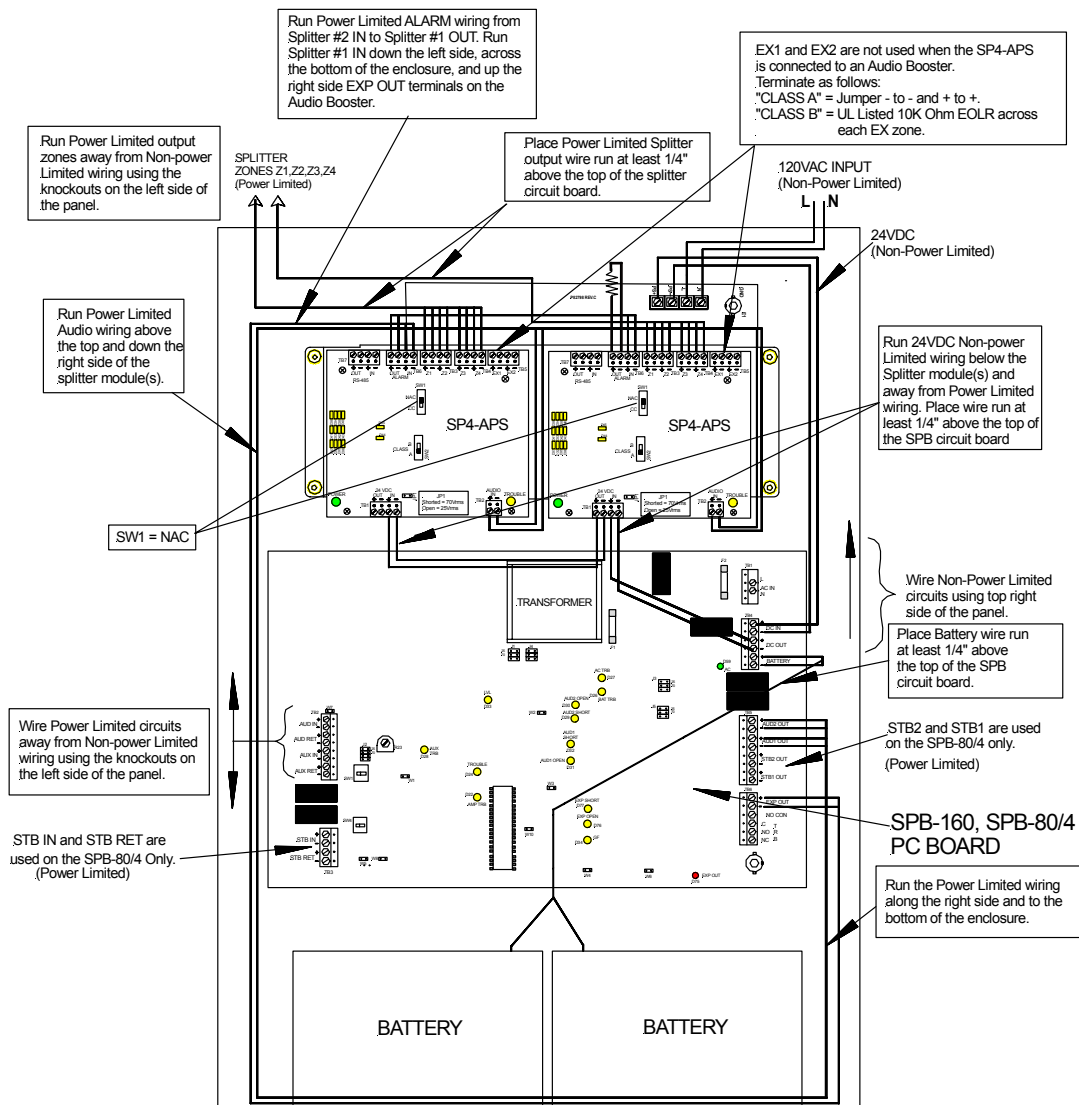

Figure 11:
Power Limited Wiring Diagram
For Connecting Two SP4-APS Splitters To An SPB-160 (Or One To An SPB-80/4).

5.3 MOUNTING INSTRUCTIONS: (SPB-320)

The SP4-APS modules are mounted inside SPB-320 enclosure using two Splitter Mounting Brackets (SPMB4Z - purchased separately). Each SPMB4Z is mounted above the corresponding SPB-160 module as shown in Figure 12.

1. Mount the Splitter Mounting Bracket (SPMB4Z) to the SPB-320 according to the SPMB4Z installation instructions (P84252).
2. Mount the splitters to the mounting bracket according to the mounting instructions in Section 5.1 Mounting Instruction (SPB-160 and SPB-80/4).

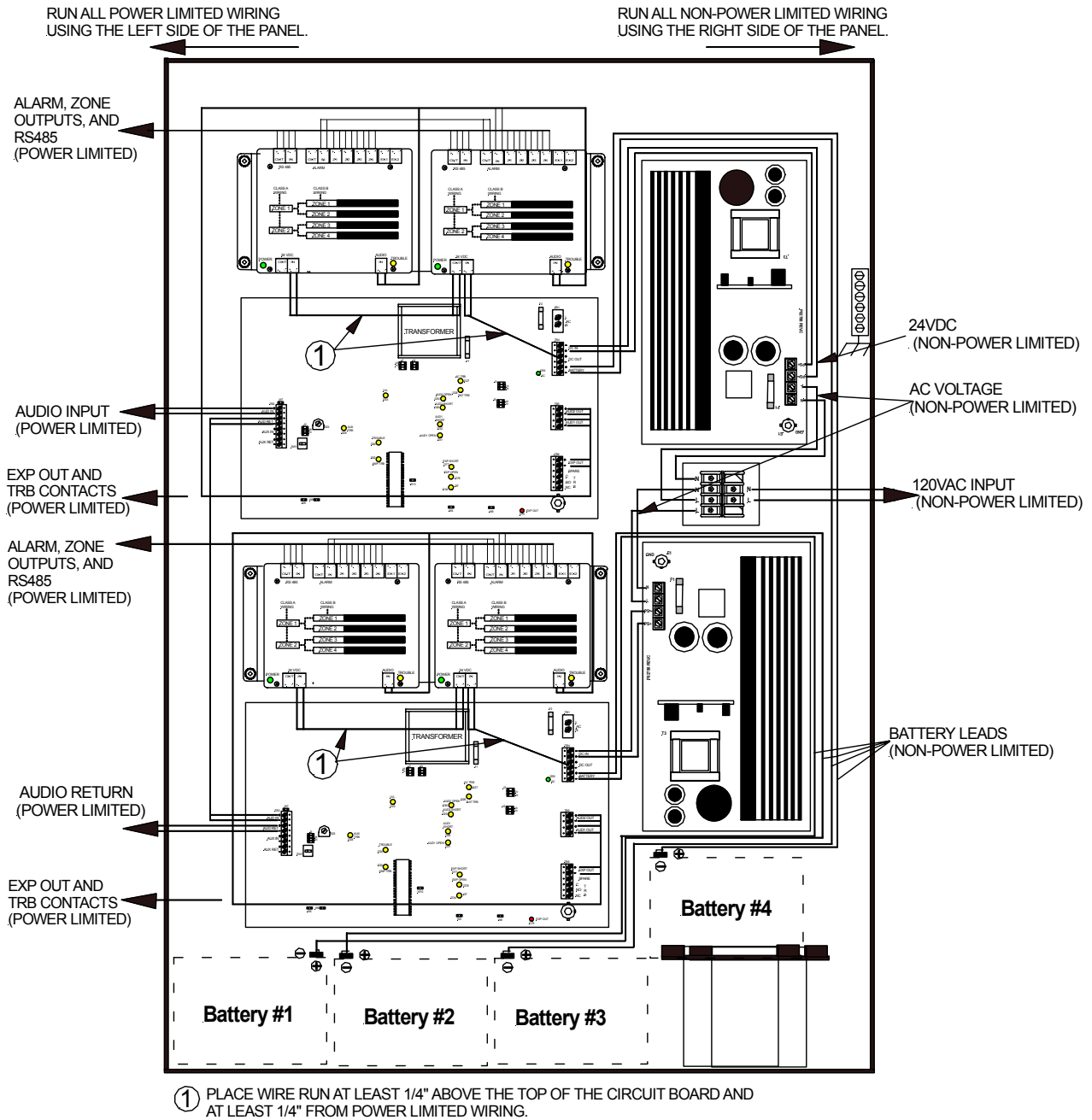

Figure 12:
Power Limited Diagram Showing Four SP4-APS Splitters In An SPB-320

Figure 12 shows the proper separation of Power Limited and Non-Power Limited wiring for the SPB-320 audio booster.

5.4 SPB-320 Wiring

Figure 13 shows the proper wiring for the two SP4-APS modules attached to the top SPB-160 module in the SPB-320. All other wiring for the lower SPB-160 module is done the same way as the top module.

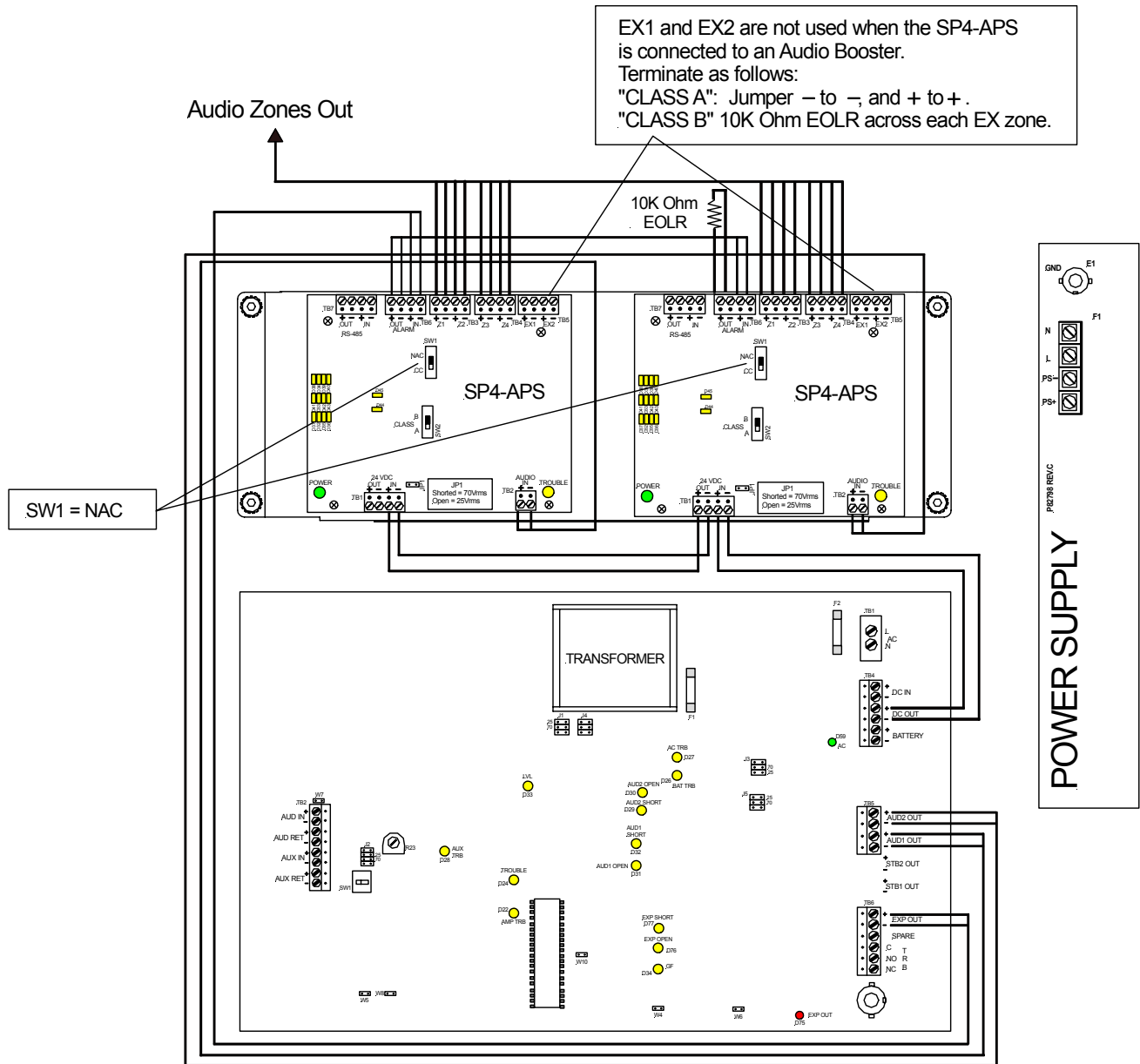

Figure 13:
Wiring Diagram
For Connecting Two SP4-APS Splitters To One Of The Two SPB-160 PC Boards IN An SPB-320.

6.0 OPERATING INSTRUCTIONS:

Figure 14 shows the SP4-APS PC board layout.

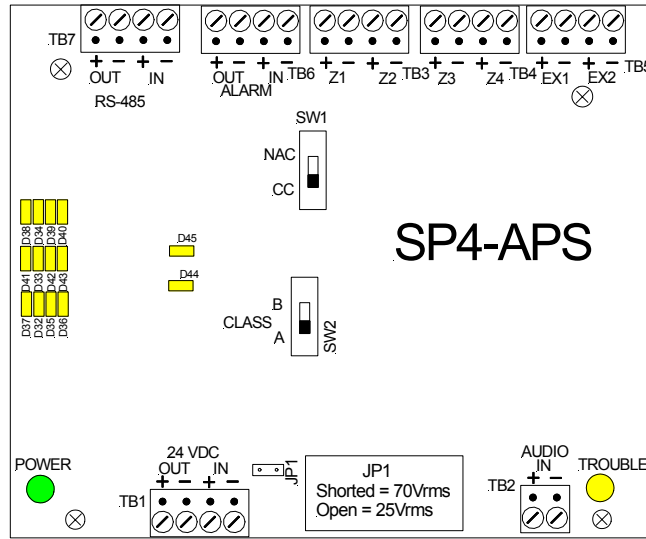

Figure 14:
SP4-APS PC Board Layout

6.1 MODES OF OPERATION:

6.1.1 STANDBY MODE:

Standby mode occurs when the Addressable Paging Splitter is not in ALARM and is not selected for BGM or a Telephone Page. Standby mode is indicated when only the GREEN power LED indicator is ON.

6.1.2 BACKGROUND MUSIC MODE:

Background Music Mode occurs when the SP4-TZC sends BGM commands to Addressable Paging Splitter Modules (s) via RS-485 digital control signals. By default, The SP4-TZC selects all available zones on all SP4-APS for BGM so that each SP4-APS enables its four available audio output zones. Zone specific BGM selection can be accomplished through the SP4-TZC module using the SP4 Telzone Programmer software. See the SP4-TZC installation sheet (P84567) for further information.

6.1.3 TELEPHONE PAGING MODE:

Paging Mode occurs when telephone-paging commands are sent from the SP4-TZC to the SP4-APS Splitter(s) via RS-485 digital control signals (See Figure 13 for location). See the SP4-TZC installation sheet (P84567) for further information on the RS485 connections. When the addressed SP4-APS receives the paging command, it enables the selected zones audio output relays to allow audio to pass. The SP4-TZC will send commands to all networked SP4-APS modules not selected for paging to turn off their audio output zones.

6.1.4 ALARM MODE:

Alarm Mode occurs when an alarm signal initiates the SP40/2 into an alarm condition, or when the SP4-APS ALARM input or output wiring is in trouble. When the SP4-APS module is in ALARM, it turns on all audio output zones and ignores any SP4-TZC paging and/or BGM commands. When the SP4-APS is installed with an SP-40/2 it must be set for "CC MODE" (Contact Closure). When the SP4-APS is installed with an Audio Booster product it must be set for "NAC MODE." The SP4-APS uses 3.0mA at 24VDC in the NAC mode. See Figure 14 for the location of the ALARM terminals.

7.0 TROUBLESHOOTING PROCEDURES:

The SP4-APS supervises all output zones and the module itself for trouble conditions. If a trouble condition is detected the yellow GENERAL TROUBLE LED indicator is “ON”.

- If the SP4-APS is connected to the SP40/2, the TROUBLE and the AUDIO SHORT LED indicators on the SP40/2 will also be “ON”.
- If the SP4-APS is connected to an Audio Booster (SPB-160, SPB-80/4, SPB-320), the TROUBLE and the AUDIO SHORT LED indicators on the Audio Booster will also be “ON”.

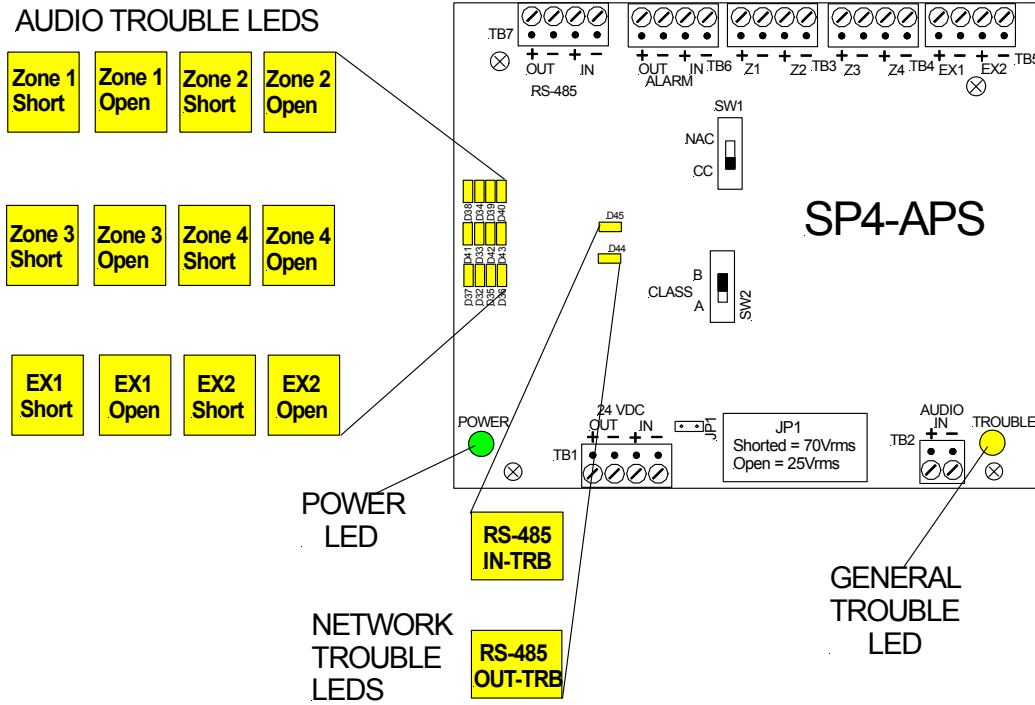

Figure 15:
SP4-APS Power and Trouble LED Indicators

Figure 15 shows the Power and Trouble LED indicators on the SP4-APS PC board.

1. Ensure that the green POWER LED is “ON”. If no LED's are lighted, check the 24VDC input power.
2. Verify that SW1 (NAC/CC) switch is set to the desired position.
3. Verify the SW2 (CLASS A or B) is set to the correct zone circuit configuration.
4. Verify wiring is correct.
5. If the yellow TROUBLE LED is “ON” an output circuit supervision trouble or module trouble is indicated. Remove the SP4-APS cover and observe the 12 yellow AUDIO TROUBLE LED's as shown in Figure 14 to determine the reason for the trouble using Table 3. (NETWORK TROUBLE LED's are used when the SP4-APS is used with the Telephone Zone Controller (SP4-TZC)).
6. For each SHORT LED “ON”, check the speaker output wiring for that zone for a short or a faulty speaker appliance.
7. For each OPEN LED “ON”, check the speaker wire run for that zone for an open or that the end of line resistor (if applicable) is missing.

Table 3 shows the SP4-APS trouble conditions, LED indicators, and a Remarks section in order to help diagnose the trouble.

Table 3: Troubleshooting

SP4-APS Trouble Conditions			Audio Zone LEDs		RS485 LEDs	Remarks
Trouble Name	Reports Trouble	General TROUBLE LED	Zone (X) SHORT LED	Zone (X) OPEN LED	RS 485 TRB LED	
Zone Audio Output Major Short	X	X	X			Shorted Wiring or Appliance on Audio Zone. Audio Zone disabled. See Note 1.
Zone Audio Output Minor Short	X	X	X			Shorted Wiring or Appliance on Audio Zone. Audio enabled. See Note 1
Zone Audio Output Open	X	X		X		Open wiring on Audio Zone or End of Line Resistor missing. Audio Zone enabled to the point of the open. See Note 1.
Alarm Short	X	X				Alarm wiring shorted together. See Note (“NAC Mode” Only)
Alarm Open	X	X				Alarm wiring open or not connected. See Note 1. (“NAC Mode” or “CC Mode”)
RS485 IN Short					X	RS485 IN wiring shorted together. Subsequent SP4-APS’s will have the RS485 IN LED ON .
RS485 IN Open					X	RS485 IN wiring open. No communication to SP4-APS and subsequent splitters. Subsequent SP4-APS’s will have the RS485 IN LED ON
RS485 OUT Short					X	RS485 OUT wiring shorted together. No communication to subsequent SP4-APS’s. Subsequent SP4-APS’s will have the RS485 IN LED ON .
RS485 OUT Open					X	RS485 OUT wiring open. No communication to subsequent SP4-APS’s. Subsequent SP4-APS’s will have the RS485 IN LED ON
24VDC Wiring Disconnected	X					All LED indicator will be OFF . See Note 2.
Ground Fault on any terminal except RS485	X					No indication on SP4-APS. Trouble LED and Ground Fault LED indicators will light on the SP40/2 or Audio Booster powering the SP4-APS.

NOTE 1: All SP4-APS trouble conditions, except RS485 trouble conditions, will cause a trouble condition on the SP40/2 or Audio Booster (SPB-160, SPB-80/4, SPB-320) that is powering the SP4-APS. The TROUBLE and AUDIO SHORT LED indicators will light on the corresponding SP40/2 or Audio Booster.

NOTE 2: If the 24VDC input wiring from the Audio Source (SP40/2 or Audio Booster) is not connected to the SP4-APS and the Audio Input is connected, the TROUBLE LED on the Audio Source will be **ON** as well as the AUDIO SHORT trouble LED. The SP4-APS will play audio out of all zones.

ANY MATERIAL EXTRAPOLATED FROM THIS DOCUMENT OR FROM WHELOCK MANUALS OR OTHER DOCUMENTS DESCRIBING THE PRODUCT FOR USE IN PROMOTIONAL OR ADVERTISING CLAIMS, OR FOR ANY OTHER USE, INCLUDING DESCRIPTION OF THE PRODUCT'S APPLICATION, OPERATION, INSTALLATION AND TESTING IS USED AT THE SOLE RISK OF THE USER AND WHELOCK WILL NOT HAVE ANY LIABILITY FOR SUCH USE.

Limited Warranty

Wheelock products must be used within their published specifications and must be PROPERLY specified, applied, installed, operated, maintained and operationally tested in accordance with these instructions at the time of installation and at least twice a year or more often and in accordance with local, state and federal codes, regulations and laws. Specification, application, installation, operation, maintenance and testing must be performed by qualified personnel for proper operation in accordance with all of the latest National Fire Protection Association (NFPA), Underwriters' Laboratories (UL), Underwriters' Laboratories of Canada (ULC), National Electrical Code (NEC), Occupational Safety and Health Administration (OSHA), local, state, county, province, district, federal and other applicable building and fire standards, guidelines, regulations, laws and codes including, but not limited to, all appendices and amendments and the requirements of the local authority having jurisdiction (AHJ). Wheelock products when properly specified, applied, installed, operated, maintained and operationally tested as provided above are warranted against mechanical and electrical defects for a period of three years from date of manufacture (as determined by date code). Correction of defects by repair or replacement shall be at Wheelock's sole discretion and shall constitute fulfillment of all obligations under this warranty. THE FOREGOING LIMITED WARRANTY SHALL IMMEDIATELY TERMINATE IN THE EVENT ANY PART NOT FURNISHED BY WHEELOCK IS INSTALLED IN THE PRODUCT. THE FOREGOING LIMITED WARRANTY SPECIFICALLY EXCLUDES ANY SOFTWARE REQUIRED FOR THE OPERATION OF OR INCLUDED IN A PRODUCT. WHEELOCK MAKES NO REPRESENTATION OR WARRANTY OF ANY OTHER KIND, EXPRESS, IMPLIED OR STATUTORY WHETHER AS TO MERCHANTABILITY, FITNESS FOR A PARTICULAR PURPOSE OR ANY OTHER MATTER.

USERS ARE SOLELY RESPONSIBLE FOR DETERMINING WHETHER A PRODUCT IS SUITABLE FOR THE USER'S PURPOSES, OR WHETHER IT WILL ACHIEVE THE USER'S INTENDED RESULTS. THERE IS NO WARRANTY AGAINST DAMAGE RESULTING FROM MISAPPLICATION, IMPROPER SPECIFICATION, ABUSE, ACCIDENT OR OTHER OPERATING CONDITIONS BEYOND WHEELOCK'S CONTROL.

SOME WHEELOCK PRODUCTS CONTAIN SOFTWARE. WITH RESPECT TO THOSE PRODUCTS, WHEELOCK DOES NOT WARRANTY THAT THE OPERATION OF THE SOFTWARE WILL BE UNINTERRUPTED OR ERROR-FREE OR THAT THE SOFTWARE WILL MEET ANY OTHER STANDARD OF PERFORMANCE, OR THAT THE FUNCTIONS OR PERFORMANCE OF THE SOFTWARE WILL MEET THE USER'S REQUIREMENTS. WHEELOCK SHALL NOT BE LIABLE FOR ANY DELAYS, BREAKDOWNS, INTERRUPTIONS, LOSS, DESTRUCTION, ALTERATION, OR OTHER PROBLEMS IN THE USE OF A PRODUCT ARISING OUT OF OR CAUSED BY THE SOFTWARE.

THE LIABILITY OF WHEELOCK ARISING OUT OF THE SUPPLYING OF A PRODUCT, OR ITS USE, WHETHER ON WARRANTIES, NEGLIGENCE, OR OTHERWISE, SHALL NOT IN ANY CASE EXCEED THE COST OF CORRECTING DEFECTS AS STATED IN THE LIMITED WARRANTY AND UPON EXPIRATION OF THE WARRANTY PERIOD ALL SUCH LIABILITY SHALL TERMINATE. WHEELOCK IS NOT LIABLE FOR LABOR COSTS INCURRED IN REMOVAL, REINSTALLATION OR REPAIR OF THE PRODUCT BY ANYONE OTHER THAN WHEELOCK OR FOR DAMAGE OF ANY TYPE WHATSOEVER, INCLUDING BUT NOT LIMITED TO, LOSS OF PROFIT OR INCIDENTAL OR CONSEQUENTIAL DAMAGES. THE FOREGOING SHALL CONSTITUTE THE SOLE REMEDY OF THE PURCHASER AND THE EXCLUSIVE LIABILITY OF WHEELOCK.

IN NO CASE WILL WHEELOCK'S LIABILITY EXCEED THE PURCHASE PRICE PAID FOR A PRODUCT.

Limitation of Liability

WHEELOCK'S LIABILITY ON ANY CLAIM OF ANY KIND, INCLUDING NEGLIGENCE AND BREACH OF WARRANTY, FOR ANY LOSS OR DAMAGE RESULTING FROM, ARISING OUT OF, OR CONNECTED WITH THIS CONTRACT, OR FROM THE MANUFACTURE, SALE, DELIVERY, RESALE, REPAIR OR USE OF ANY PRODUCT COVERED BY THIS ORDER SHALL BE LIMITED TO THE PRICE APPLICABLE TO THE PRODUCT OR PART THEREOF WHICH GIVES RISE TO THE CLAIM. WHEELOCK'S LIABILITY ON ANY CLAIM OF ANY KIND SHALL CEASE IMMEDIATELY UPON THE INSTALLATION IN THE PRODUCT OF ANY PART NOT FURNISHED BY WHEELOCK. IN NO EVENT SHALL WHEELOCK BE LIABLE FOR ANY CLAIM OF ANY KIND UNLESS IT IS PROVEN THAT OUR PRODUCT WAS A DIRECT CAUSE OF SUCH CLAIM. FURTHER, IN NO EVENT, INCLUDING IN THE CASE OF A CLAIM OF NEGLIGENCE, SHALL WHEELOCK BE LIABLE FOR INCIDENTAL OR CONSEQUENTIAL DAMAGES. SOME STATES DO NOT ALLOW THE EXCLUSION OR LIMITATION OF INCIDENTAL OR CONSEQUENTIAL DAMAGES, SO THE PRECEDING LIMITATION MAY NOT APPLY TO ALL PURCHASERS.