

SP40S
Multi-Function Facility
Communication System

**Installation, Testing,
Operation, and
Maintenance
Manual**

About Cooper Wheelock, Inc.: Cooper Wheelock, Inc. fulfills its mission of Helping People Take Action by providing high quality and advanced products and services for the life safety, communications, and security markets. Cooper Wheelock has served the needs of commercial, educational, industrial, health care, and government users for more than eighty-five years.

Today the company continues to focus on designing and manufacturing advanced technological products to meet the world's needs for Emergency Incident Management and Notification, Multi-Function Communications, and Mass Notification.

For more information, contact:

Cooper Wheelock, Inc.
273 Branchport Avenue
Long Branch, NJ 07740-6899
Telephone: (800) 631.2148
Fax: (732) 222.2588
Web Site: www.cooperwheelock.com
E-Mail: info@cooperwheelock.com

Table of Contents

Chapter: 1 Foreword	1
1.1 Intended Use.....	1
1.2 Design Change Disclaimer.....	1
1.3 User Operation Assistance	1
1.4 Typographical Notation Conventions	2
Chapter: 2 Safety Precautions	1
2.1 Read This Manual	1
2.2 Operational Safety.....	1
2.2.1 Expected Equipment Lifecycle	2
2.2.2 Periodic Testing	2
2.3 Compliance with Applicable Codes, Regulations, Laws, Standards, and Guidelines....	3
2.4 Insurance Recommendation	3
2.5 Audio Output Considerations.....	3
2.6 RF Interference.....	4
2.7 General	4
Chapter: 3 Overview	1
3.1 Compatibility with Existing Safepath4 Products	1
3.2 Standard Features	2
3.3 Enclosure and Configuration.....	5
3.4 Nominal Electrical Data	5
3.5 User Interface	6
3.5.1 Basic Operation of User Interface.....	6
3.6 Additional Drawings	8
3.7 User Settings	144
3.7.1 Switch Descriptions	144
3.7.2 Jumper Descriptions	177
3.7.3 LED Descriptions.....	188
Chapter: 4 Installation	1
4.1 Introduction	1
4.2 Fire Alarm Control Panel Wiring Applications	1
4.3 General Installation Instructions	2
4.4 Preparing the System Wiring Diagram	6
?<4.4.1 Unpacking and Taking Inventory	6
4.4.2 Locating the Panel	6
4.4.3 Installing Field Wiring Connections.....	9
4.4.4 Installing Strobe Connections.....	9
4.4.5 Installing Audio Output Connections	10
4.4.6 Installing Auxiliary Circuit Connections	11
4.4.7 Installing Audio Input Connections	11

4.4.8	Installing Digital Voice Initiating Connections	11
4.4.9	Installing Ancillary Audio Input Connections	12
4.4.10	Setting Adjustable Audio BGM Sources	13
4.4.11	Installing Alarm, System Trouble, and AC Trouble Output Connections	14
4.5	Wiring the System	15
4.5.1	Wiring Guidelines	15
4.5.2	Field Wiring Connections	15
4.5.3	Preparing a System Wiring Diagram	15
4.5.4	Visual Notification Appliance Output Wiring	16
4.5.5	Speaker Notification Appliance Output Wiring	16
4.5.6	Wiring Diagrams for Audio/Visual Notification Appliances	16
4.5.7	Wiring the Alarm Output Contact	17
4.5.8	Wiring the System Trouble Connections	18
4.6	Performing System Checkout	19
4.6.1	System Control Settings	19
4.6.2	Checkout Procedure	19
4.7	Ground Fault Detection	21
4.8	Battery Care and Backup Battery Calculations	22
4.8.1	Caring for Sealed Lead Acid Batteries	22
4.8.2	Storing Batteries	22
4.8.3	Calculating Backup Battery Requirements	22
4.9	Installing AC Power and Batteries	24
4.9.1	Installing AC Power	24
4.9.2	Installing Batteries	25
Chapter: 5 Operation		1
5.1	Introduction	1
5.2	User Interface	1
5.3	Supervision	1
5.3.1	Visual Notification Appliance Output Circuit Supervision	2
5.3.2	Audio Notification Appliance Output Circuit Supervision	2
5.3.3	Amplifier Supervision	2
5.3.4	Ground Fault Supervision	2
5.4	Actions that Initiate Audio Alarms	3
Chapter: 6 Operational Procedures		1
6.1	Making Live Announcements	1
6.2	Recording Digital Voice Messages	1
6.3	Recording Messages on the Digital Voice Section	2
6.4	Verifying Messages	3
Chapter: 7 Periodic Testing and Maintenance		1
7.1	Introduction	1
7.2	Periodic Testing	1
7.2.1	Test Frequency	1
7.2.2	Equipment	1
7.3	Faulty Equipment	1

7.4	Qualified Personnel.....	2
Chapter: 8	Troubleshooting	1
8.1	Introduction.....	1
8.2	General.....	2
8.2.1	Procedure A.....	5
8.2.2	Procedure B.....	5
8.2.3	Procedure C.....	6
8.2.4	Procedure D.....	6
8.2.5	Procedure E.....	7
8.2.6	Procedure F.....	7
8.2.7	Procedure G.....	7
8.2.8	Procedure H.....	8
8.2.9	Procedure I.....	8
8.2.10	Procedure J.....	9
8.2.11	Procedure K.....	9
8.2.12	Procedure L.....	9
8.2.13	Procedure M.....	10
8.2.14	Procedure N.....	10
8.2.15	Procedure O.....	10
8.2.16	Procedure P.....	11
8.2.17	Procedure Q.....	11
8.2.18	Procedure R.....	11
8.2.19	Procedure S.....	12
Chapter: 9	Technical Data	1
9.1	Mechanical.....	1
9.2	Environmental.....	1
9.3	Electrical.....	2
9.3.1	Input.....	2
9.3.2	Battery Current Calculations.....	2
9.3.3	Activation.....	2
9.3.4	Outputs.....	3
9.4	Wiring Connections.....	3
9.4.1	End of Line Resistor (EOLR).....	3
Chapter: 10	Warranty	1
10.1	Limited Warranty.....	1
10.2	Limitation of Liability.....	2
Chapter: 11	Battery Backup Calculation Worksheet	1

List of Figures

Figure 3-1	Basic Capabilities of the SP40S Panel	4
Figure 3-2	Layout of SP40S Panel	5
Figure 3-3	SP40S User Interface.....	6
Figure 3-4	SP40S Terminal Blocks.....	8
Figure 3-5	SP40S Jumpers	9
Figure 3-6	SP40S Switches	10
Figure 3-7	Diagnostic LEDs/Fuses	11
Figure 3-8	SP40S Potentiometers	12
Figure 3-9	Grounding Screws and grounding Standoff Locations	3-13
Figure 4-1	Location of Field Wiring Connections	2
Figure 4-2	SP40S Panel Mounting and Grounding Location.....	7
Figure 4-3	Removable Terminal Block.....	9
Figure 4-4	Strobe Connections.....	10
Figure 4-5	Audio Output Connections	11
Figure 4-6	Digital Voice Initiating Connections.....	11
Figure 4-7	Ancillary Audio Input Connections.....	12
Figure 4-8	Wiring Diagram for Visual Only Notification Appliances.....	16
Figure 4-9	Wiring Diagram for Combination Audio/ Visual Notification Appliances.....	17
Figure 4-10	Wiring Diagram for Audio Only Notification Appliance Output.....	17
Figure 4-11	Alarm Connections	18
Figure 4-12	System Trouble Connections (Trouble Status Relay Contact)	18
Figure 4-13	120VAC Input Connection.....	24
Figure 4-14	Battery Wire Connections	25
Figure 4-15	Battery Alignment and Jumper Connection	26
Figure 6-1	SP40S User Interface.....	3
Figure 8-1	Trouble LED and Fuse Locations.....	4

This page is left blank intentionally.

List of Tables

Table 3-1. SP40S User Interface Pushbuttons/Indicators.....	3-6
Table 4-1. Terminal Block Connection Definitions	4-3
Table 4-2. Digital Voice Message Tests.....	4-20
Table 5-1. Audio Alarm Conditions and Results	5-3
Table 8-1. Trouble LED Procedure Cross Reference.....	8-3

This page is left blank intentionally.

1 Foreword

1.1 Intended Use

This manual is designed to serve the installers and operators of the SP40S Multi-Function Facility Communication System. All operating instructions, product illustrations, troubleshooting/error messages, and other relevant information are contained in this manual. It is the user's responsibility to ensure that all instructions in this manual are applied strictly.

1.2 Design Change Disclaimer

Due to design changes and product improvements, information in this manual is subject to change without notice. Cooper Wheelock reserves the right to change product design, including illustrations and diagrams, at any time without notice to anyone, which may subsequently affect the contents of this manual.

Cooper Wheelock assumes no responsibility for any errors that may appear in this manual. Cooper Wheelock will make every reasonable effort to ensure that this manual is up to date and corresponds with the shipped Cooper Wheelock SP40S Multi-Function Facility Communication System.

1.3 User Operation Assistance

Should you experience any difficulty in installing or operating your SP40S Multi-Function Facility Communication System, please contact your Cooper Wheelock representative. The Troubleshooting chapter in this manual (Chapter 8) includes a list of common system problems, possible causes, and corrective operator actions. The information given here is general. Feel free to contact the Technical Support department of Cooper Wheelock at 1-800-631-2148. Hours are 8:00 a.m. - 7:00 p.m. (Eastern Time), Monday through Thursday and 8:00 a.m. – 5:00 p.m. (Eastern Time) on Friday.

1.4 Typographical Notation Conventions

Thank you for using our products. Use this product according to this instruction manual. Please keep this instruction manual for future reference.

Any material extrapolated from this document or from Cooper Wheelock manuals or other documents describing the product for use in promotional or advertising claims, or for any other use, including description of the product's application, operation, installation, and testing is used at the sole risk of the user and Cooper Wheelock will not have any liability for such use.

Certain information contained in this manual has been extracted from the NFPA 72 Manual and the Life Safety Code 101™ Manual.

WARNINGS

 **WARNING: A Warning indicates a potentially hazardous situation that, if not avoided, could result in serious personal injury or death to you or others. Warnings are set off in boldface type, within boxed rules, indented, and referenced to a warning symbol.**

CAUTIONS



CAUTIONS: Indicate a situation in which the equipment could be damaged or a situation in which not following the instructions correctly could result in the equipment not working properly. Cautions are set off with a stop sign symbol.

2 Safety Precautions

2.1 Read This Manual

1. Cooper Wheelock recommends that, before performing any actions to specify, apply, install, maintain, and operationally test the SP40S Multi-Function Facility Communication System, personnel properly qualified in the application and use of life safety equipment read this manual carefully.
2. Keep this manual with the SP40S Multi-Function Facility Communication System for reference during the life of the product. Make this manual available to all qualified personnel who operate, test, maintain, or service the SP40S Multi-Function Facility Communication System. It is strongly recommend that such personnel read and understand the entire manual.

2.2 Operational Safety

 **WARNING:** If safety precautions, installation, and testing instructions are not performed properly, the SP40S Multi-Function Facility Communication Systems may not operate in an emergency situation, which could result in serious injury or death to you and/or others.

 **WARNING:** If the protective signaling system sounds and/or flashes, it is a warning that a possible serious situation requires immediate attention.



CAUTION: A SP40S Multi-Function Facility Communication System printed circuit board is sensitive to static electricity and has delicate components mounted on it.

- (a) Before handling the board or any component on it, discharge any static electricity from your body by touching a grounded object, such as a metal screw, which is connected to earth ground.
- (b) Handle the board by its edges and be careful not to twist or flex it. Install the SP40S Multi-Function Facility Communication System in a static-free area.
- (c) Attach grounded wrist straps properly before touching any static sensitive areas.
- (d) After handling a SP40S Multi-Function Facility Communication System printed circuit board, test the panel as described in section 4.6 to verify that it is functioning properly.

NOTE: In areas prone to lighting strikes, using a surge protection device is recommended. Reference TESAN number S002-99 for recommended manufacturers of surge protection equipment.

This TESAN (Technical Engineering Support Application Notice) is available from the Cooper Wheelock website (www.cooperwheelock.com) and is found under the Technical Support tab.

*NOTE: This SP40S Multi-Function Facility Communication System **will not work** without power. The SP40S Multi-Function Facility Communication System is powered by 120VAC. 24VDC rechargeable batteries provide backup power, should be purchased separately. If both sources of power are cut off for any reason, the SP40S Multi-Function Facility Communication System **will not operate**.*

1. DO NOT assume any installation, operation, and testing details not shown in this manual.



CAUTION: DO NOT operate the SP40S Multi-Function Facility Communication System without the dead front panel being properly in place.

2.2.1 Expected Equipment Lifecycle

Notification equipment cannot last forever. Even though the SP40S Multi-Function Facility Communication System is expected to last up to ten years, any of its parts or components could fail before then.

2.2.2 Periodic Testing

1. Cooper Wheelock recommends testing of the entire protective signaling system, including the SP40S Multi-Function Facility Communication System, all notification equipment, as well as all messages and their output channel, and priority assignment, at least twice each year, or more often as required by local, state and federal codes, regulations and laws, by qualified personnel.
2. **If the notification equipment is not working properly, immediately contact the installer and have all/any problems corrected immediately.**
3. **Replace any malfunctioning components immediately; do not attempt to repair malfunctioning components.** Return malfunctioning components for factory repair or replacement. In the event you cannot contact the installer, contact the manufacturer.



WARNING: For proper operation in life safety applications, perform the following: (a) Connect the SP40S Multi-Function Facility Communication System to a listed compatible and properly operating control panel, which controls its activation. (b) Ensure that all equipment is properly interconnected and operating. (c) Make sure the installer checks the compatibility of all equipment prior to installation; otherwise, the SP40S Multi-Function Facility Communication System and/or the control panel may be damaged and/or fail to operate in an emergency situation.

 **WARNING:** Certain hardware functions on the SP40S Multi-Function Facility Communication System are not supervised. If any such hardware functions fail, the SP40S Multi-Function Facility Communication System may not provide the intended warning and/or not indicate a trouble condition.

2.3 Compliance with Applicable Codes, Regulations, Laws, Standards, and Guidelines

Comply with all of the latest applicable codes, regulations, laws, standards, and guidelines.

 **WARNING:** Ensure that for emergency, life safety applications using the SP40S Multi-Function Facility Communication System, installation, testing and maintenance always be performed by qualified personnel in accordance with all the latest National Fire Protection Association (NFPA), Underwriter's Laboratory (UL), National Electric Code (NEC), Occupational Safety and Health Administration (OSHA), state, county, local, province, district, federal, and other applicable building and fire standards, guidelines, regulations, laws, and codes including, but not limited to, all appendices and amendments and requirements of the Local Authority Having Jurisdiction (AHJ).

It is recommended that the local Authority Having Jurisdiction (AHJ) inspect and approve the proposed placement of all the notification appliances.

2.4 Insurance Recommendation

The SP40S Multi-Function Facility Communication System is not a substitute for insurance. Make sure that you have adequate levels of life and property insurance.

2.5 Audio Output Considerations

 **WARNING:** Audible signals may mask medical equipment monitoring alarms. Where medical equipment monitoring alarms are in use, do not use audible signals; provide visual notification appliances in highly visible locations.



CAUTION: The output of the audio system may not be heard in all cases. Sound can be blocked or reduced by walls, doors, carpeting, wall coverings, furniture, insulation, bed coverings, and other obstacles that may temporarily or permanently impede the output of the audio system. Sound is also reduced by distance and masked by background noise.

The output of the audio system may not be sufficient to alert all occupants, especially those who are asleep, those who are hearing-impaired, those who are wearing devices that plug or cover the ears, and those who have recently used drugs or alcohol.

The output of the audio system may not be heard by an alert person if the output device is placed in an area which is isolated by a closed door, or is located on a different floor from the person in a hazardous situation or is placed too far away to be heard over ambient noise such as, but not limited to, running water, traffic, air conditioners, machinery or musical appliances.

If live microphone announcements, audible tones and/or voice messages cannot be readily heard and understood clearly within the protected areas as intended, increase the number and/or sound output intensity of speakers within those areas so that they are heard and understood clearly when activated.

2.6 RF Interference

The SP40S Multi-Function Facility Communication System has been tested and found to comply with the limits for a Class A digital device, pursuant to Part 15 of the FCC Rules. These limits are designed to provide reasonable protection against harmful interference when the equipment is operated in a commercial environment. This equipment generates, uses, and can radiate radio frequency energy and, if not installed and used in accordance with the instruction manual, may cause harmful interference to radio communications. Operation of this equipment in a residential area is likely to cause harmful interference, in which case the user is required to correct the interference at his own expense.

2.7 General

Each manufacturer's panel and notification appliances operate differently and have different features. Before specifying, installing, operating, testing, maintaining, or servicing a system, carefully read the installation, operation, and testing manual for each piece of equipment and applicable codes.

Additional copies of this manual may be obtained from:

Cooper Wheelock, Inc.
273 Branchport Ave.
Long Branch, N.J. 07740
Tel: (800) 631-2148
Fax: (732) 222- 2588
E-mail: info@cooperwheelock.com

3 Overview

The SP40S Multi-Function Facility Communication System is capable of supplying the following:

- 40 Watts of audio power
- 2 Amps of strobe power
- There is an additional 0.5 Amps of auxiliary power at 28 Volts that can be used to power other Safepath Products.

The SP40S Multi-Function Facility Communication System is used for Alarm and Non-Alarm Announcements.

3.1 Compatibility with Existing Safepath4 Products

The SP40S Multi-Function Facility Communication System is fully compatible with the SP40S, all current Audio Splitters (SP4Z-A/B and SP4-APS), the Safepath Remote Microphone (SPRM), the Safepath Volume Control (SP-SVC), the Telephone Zone Controller (SP4-TZC), and the Safepath Remote Microphone Expander (SP4-RMX).

3.2 Standard Features

Feature	Description
One strobe NAC output section	<ul style="list-style-type: none"> • 24VDC @ 2 Amps Maximum. • Requires separate NAC Circuit (8 to 33VDC) input or can be programmed to operate when Digital Voice messages are played. • Microphone (MIC) is active. • Auxiliary (AUX) input is active and/or Digital Voice message are played. (Each message can be programmed individually to activate the strobe circuitry.) • Return allows pass-through for Cooper Wheelock synchronized strobes, remote SP40S panels, additional strobe appliances, or EOLR. • Synchronized output when using Cooper Wheelock’s synchronized strobe products. • Supervised with 10K Ohm end-of-line resistor (EOLR). • Trouble LEDs for Open and Short conditions. • Power limited to minimize overload condition.
40-Watt Audio Amplifier section	<ul style="list-style-type: none"> • Selection of 25V or 70V speaker output. • Supervised with 10K Ohm EOLR. • Trouble LEDs for Open and Short Conditions • Power limited to avoid overload condition.
Digital Voice Section	<ul style="list-style-type: none"> • Capable of playback and record (via 1/8” audio jack). • Digital Voice Message Chip contains the recording program and memory for eight message sections. • Memory in eight sections with corresponding inputs. <ul style="list-style-type: none"> ○ A total of four minutes of messages. ○ Each message is 30 seconds in duration. ○ Messages can be combined for longer durations. • Activated by one of eight contact closure inputs (IN1 – IN8) or manual activation on user interface. • Each CC input (contact closure) can be supervised for an OPEN. • Prealert tones can be chosen for each message (code 3, continuous, or no pre-tone). • Messages can be selected to have a post-tone that matches the pre-tone. • Capable of selecting the strobe NAC output for each input.

Feature	Description
Alarm Audio Processing Section	<ul style="list-style-type: none"> • Three Priority ordered audio inputs Hand-held, push-to-talk (PTT) microphone, and Priority 1. For live, emergency voice announcements and instructions. The microphone overrides (mutes) any voice message or tones in progress. • Auxiliary Input (AUX IN, CC/NAC), Priority 2. <ul style="list-style-type: none"> ○ CC or NAC initiates AUX IN audio ○ CC is supervised. NAC is not supervised. ○ For use with SAFEPATH4 – Remote Microphone Expander (SP4-RMX) or SAFEPATH4 – Remote Microphone (SPRM) • Digital Voice Section inputs (IN1, IN2, IN3, IN4, IN5, IN6, IN7, IN8). <ul style="list-style-type: none"> ○ IN1, IN2, IN3, IN4, IN5, IN6, IN7, IN8 have priorities 3, 4, 5, 6, 7, 8, 9, and 10 respectively. ○ IN1 – IN8 are initiated via Contact Closure. ○ IN1, IN2, IN3, IN4, IN5, IN6, IN7, IN8 are supervised for an OPEN. ○ Messages can also be initiated via user interface.
Non-Alarm Audio Processing Section	<ul style="list-style-type: none"> • Night Ring (NR), Priority 6. <ul style="list-style-type: none"> ○ Contact closure activated. ○ Non-alarm. ○ Does not operate if on Battery. • Telephone Page (TEL), Priority 7. <ul style="list-style-type: none"> ○ Accepts a Telephone Page Port Input. ○ Will not operate if the panel is on Battery. • Background Music (BGM), Priority 8. <ul style="list-style-type: none"> ○ Line Level Input. ○ Will mute when any other input is used. ○ Will not operate if the panel is on Battery.
Ground Fault Detection Section	Monitors inputs and outputs for 40K Ohms minimum in relation to ground.
A Dual-Tone Tone Generator with two field selectable sounds (Code 3 Tone, Slow Whoop) that sound when there is a Digital Voice Section Failure in alarm condition.	Provides Code 3 tone or Slow Whoop (user selectable) in the instance of a Digital Voice failure or system timeout.
Full supervision with on-board diagnostics and trouble reporting circuits for:	Audio NAC circuit wiring -- open and short conditions during standby AND active (Alarm and BGM) Ground Fault detection Strobe NAC circuit wiring -- open and short conditions PTT Microphone -- not installed or damaged Amplifier -- operation Digital Voice Section Input voltage/low battery Tone generator operation

Feature	Description
Form C relay trouble contacts for external notification.	Form C contact normally energized. Contacts transfer during a trouble, an alarm trouble, or an AC trouble: 2.0 amps at 24VDC max, resistive load. Non-Supervised.
Built-in Sounder	To indicate trouble, with a trouble silence switch to silence it. If the trouble is not corrected in 20 hours, the sounder reactivates. (Trouble Silence Switch does not change the state of the Form C Trouble relay.)
Remote reporting via output contacts for system trouble, alarm activation, and AC trouble.	AC trouble can be configured for report separately or as a system trouble.

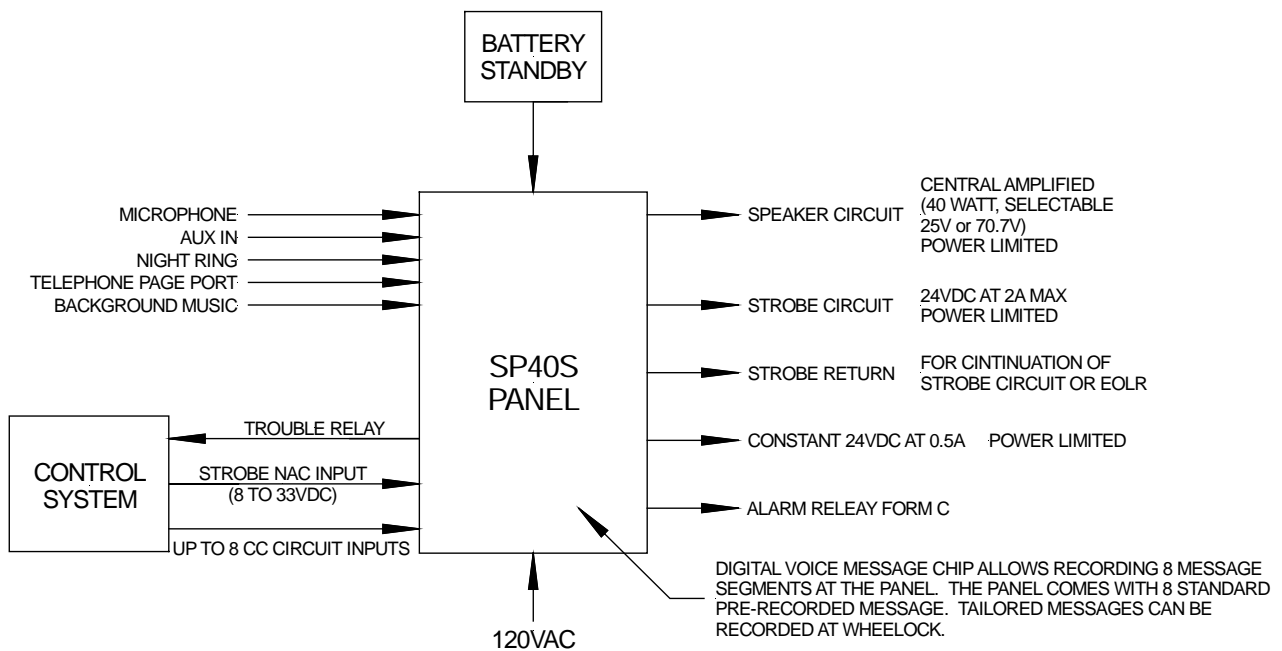

Figure 3-1 Basic Capabilities of the SP40S Panel

3.3 Enclosure and Configuration

For technical specifications, see Chapter 9.

3.4 Nominal Electrical Data

For technical specifications, see Chapter 9.

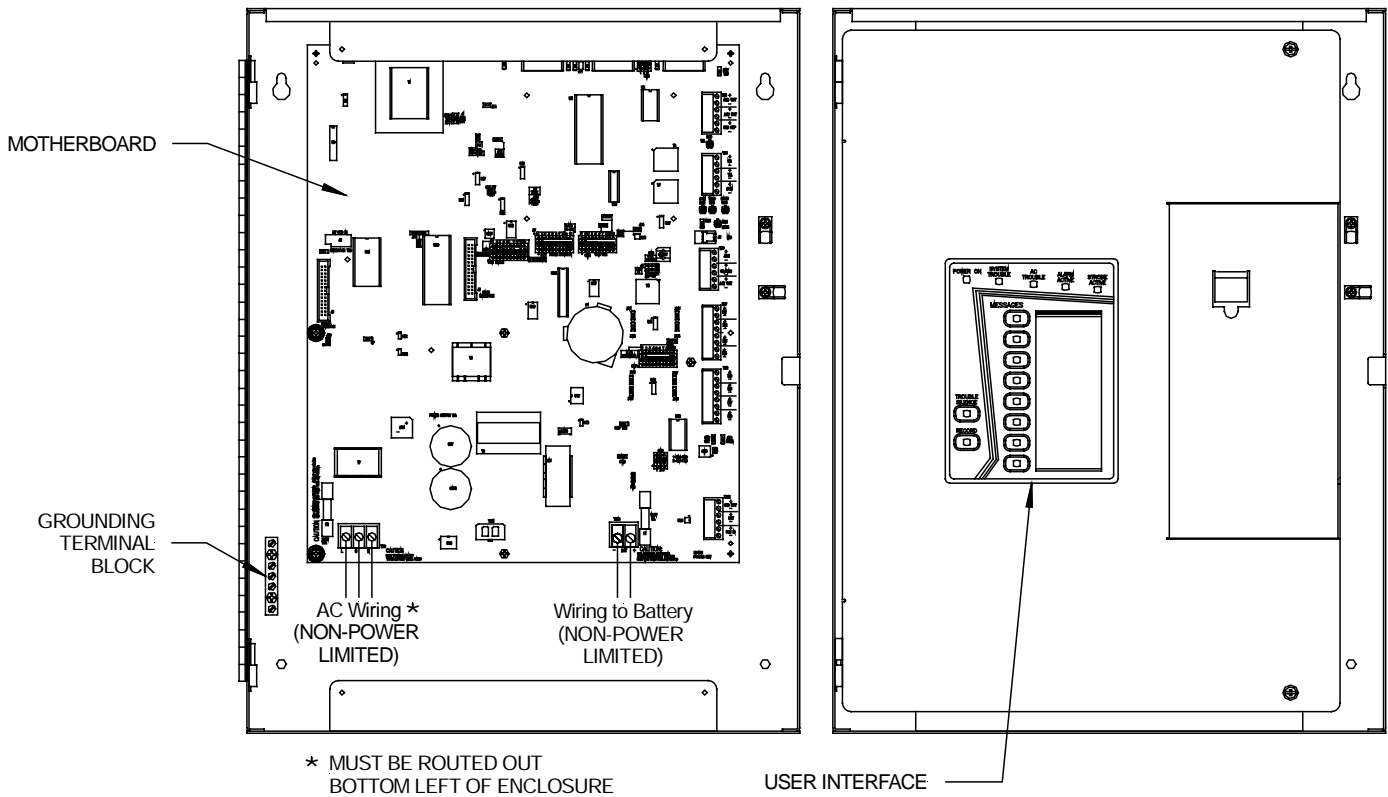

Figure 3-2 Layout of SP40S Panel

3.5 User Interface

- The User Interface of the SP40S Multi-Function Facility Communication System displays the basic status of the unit as well as allowing for a limited amount of user controls. Table 3-1 identifies the pushbuttons and indicators.

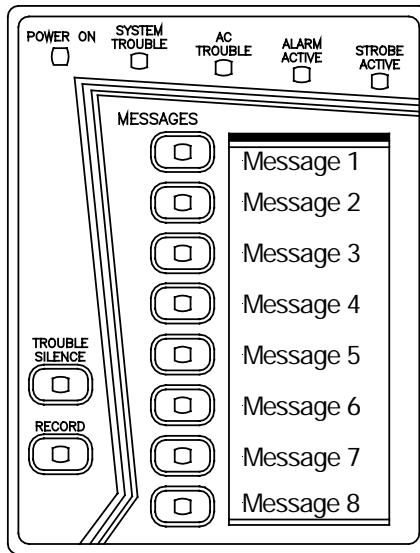

Figure 3-3 SP40S User Interface

Table 3-1. SP40S User Interface Pushbuttons/Indicators

Pushbutton or Indicator	Description/Function
Message 1 - 8 (there are 8 messages, 1 through 8)	Button manually activates Messages 1- 8. Illuminated steady means contact closure is on a DV input. Illuminated blinking means DV is activated via button push.
POWER ON indicator	If illuminated, indicates SP40S is powered by primary or secondary power.
SYSTEM TROUBLE indicator	If illuminated, indicates the SP40S has a trouble.
AC TROUBLE indicator	If illuminated, indicates primary power is low or has failed and SP40S is running on secondary power.
ALARM ACTIVE indicator	Indicates PTT MIC (push to talk microphone), AUX (auxiliary), or DV (digital voice) has been initiated.
STROBE ACTIVE indicator	Indicates the strobe circuit has been initiated.
TROUBLE SILENCE button	Temporarily silences the audible trouble indicator.
RECORD button and indicator	For message recording process, see section 6.3.

3.5.1 Basic Operation of User Interface

When a Message button is pressed, the user interface microcontroller processes the signal and outputs it to the Digital Voice microcontroller which plays the corresponding message. The user interface illuminates the corresponding message LED when a button is pressed or a message activation contact closure is received. The LED blinks if the activation was a button press and the LED remains ON constantly when a contact closure is present. If a button is pressed, the message LED remains blinking and the message remains active until the button is pressed again.

3.6 Additional Drawings

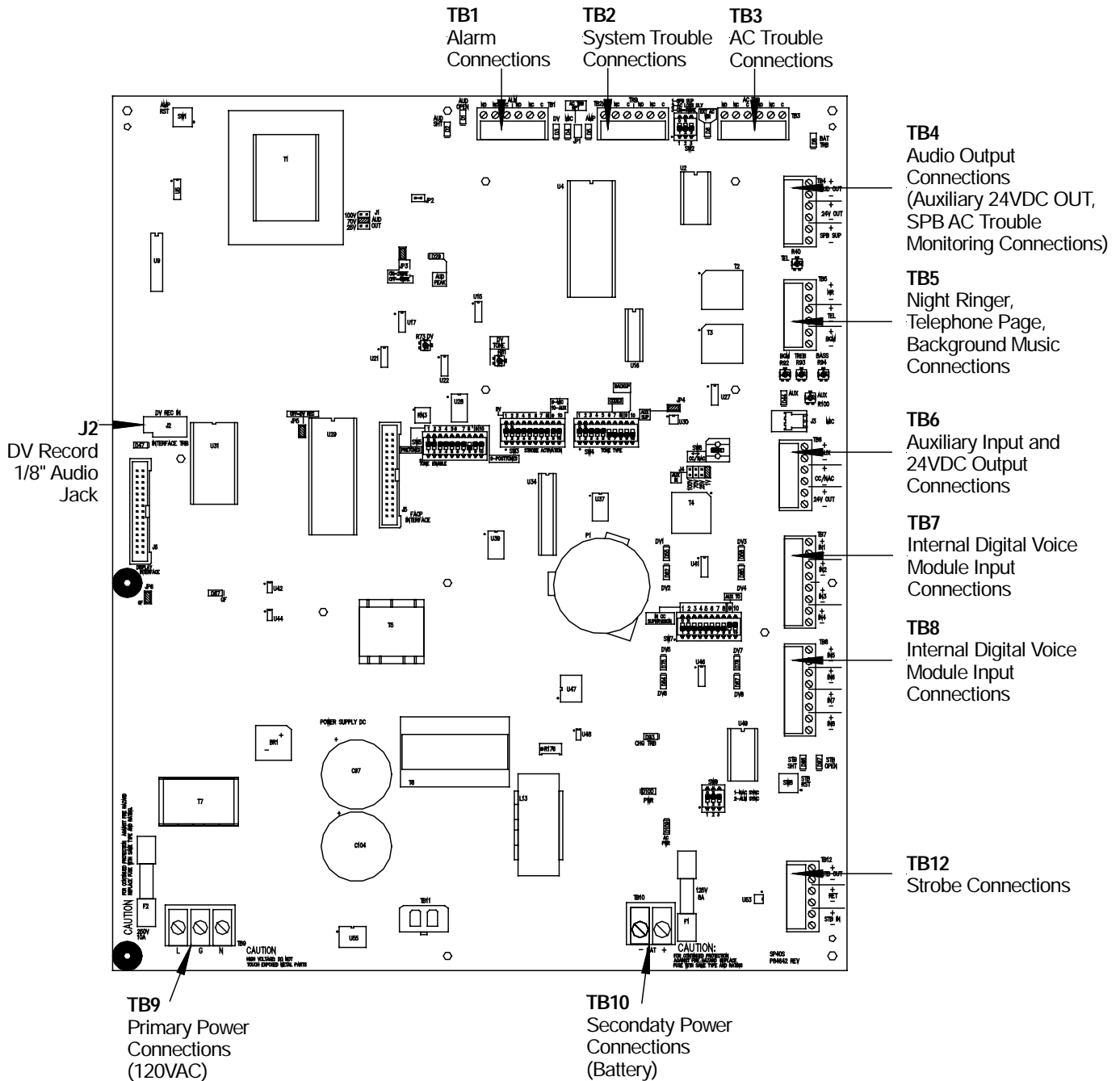

Figure 3-4 SP40S Terminal Blocks

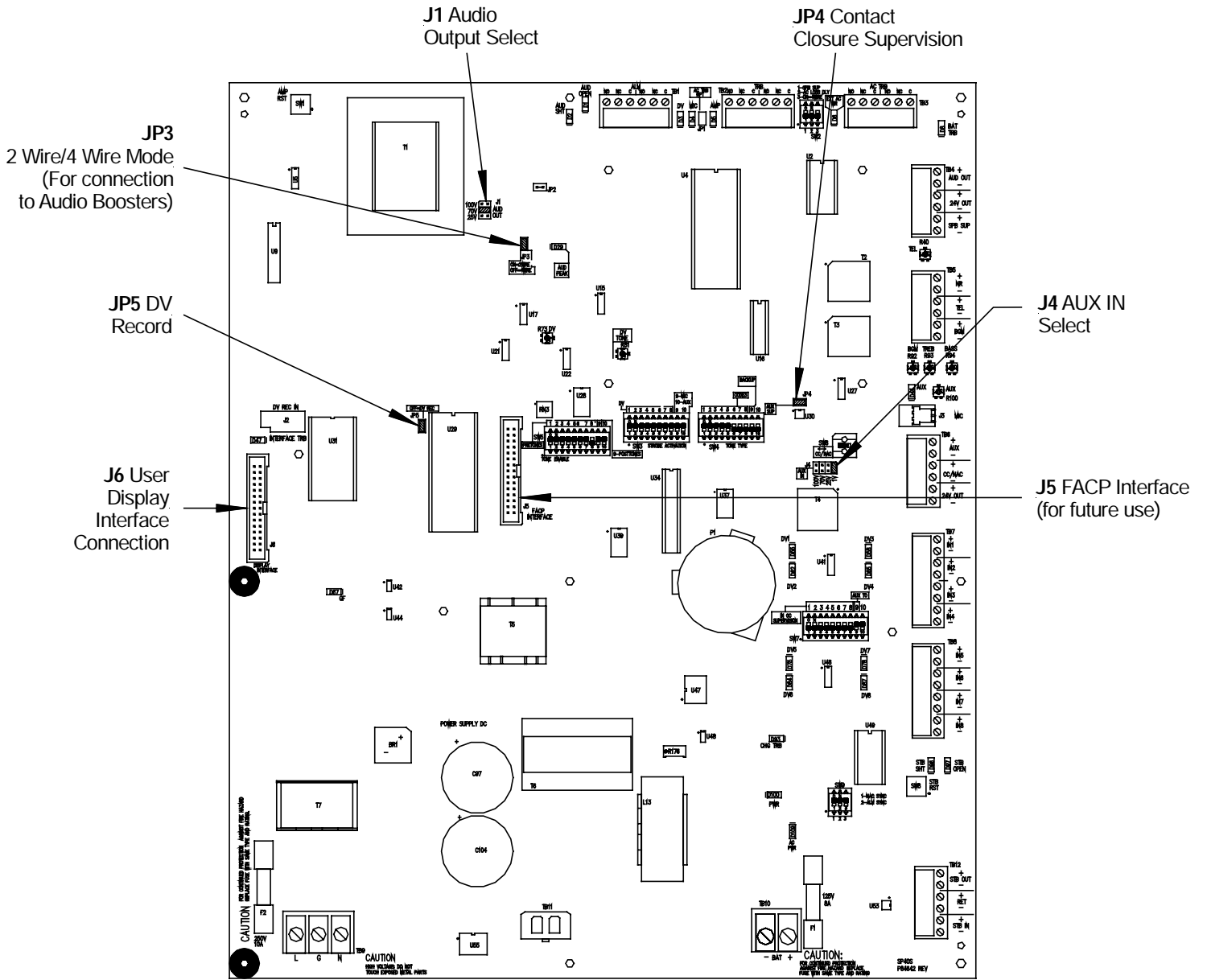

Figure 3-5 SP40S Jumpers

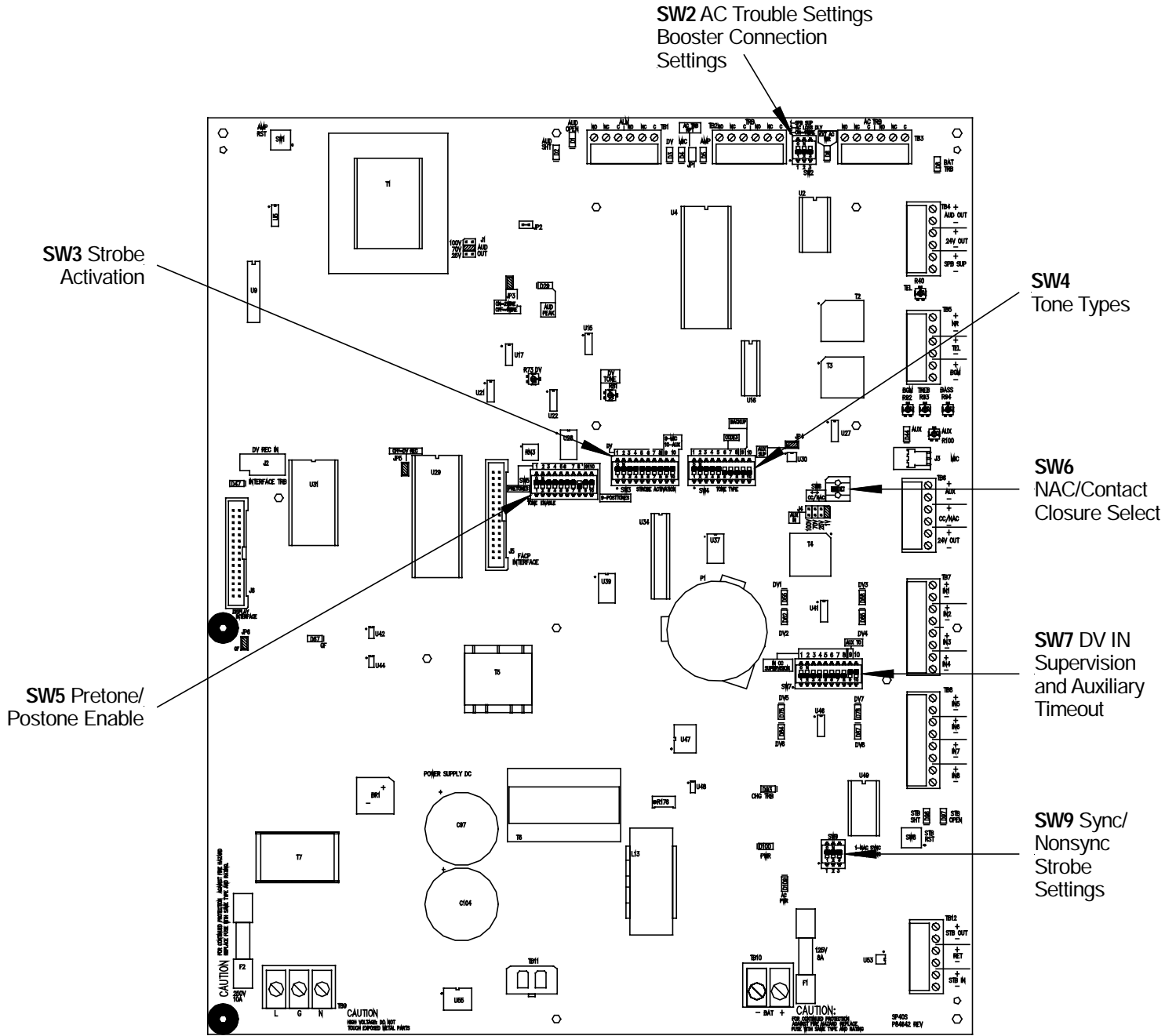

Figure 3-6 SP40S Switches

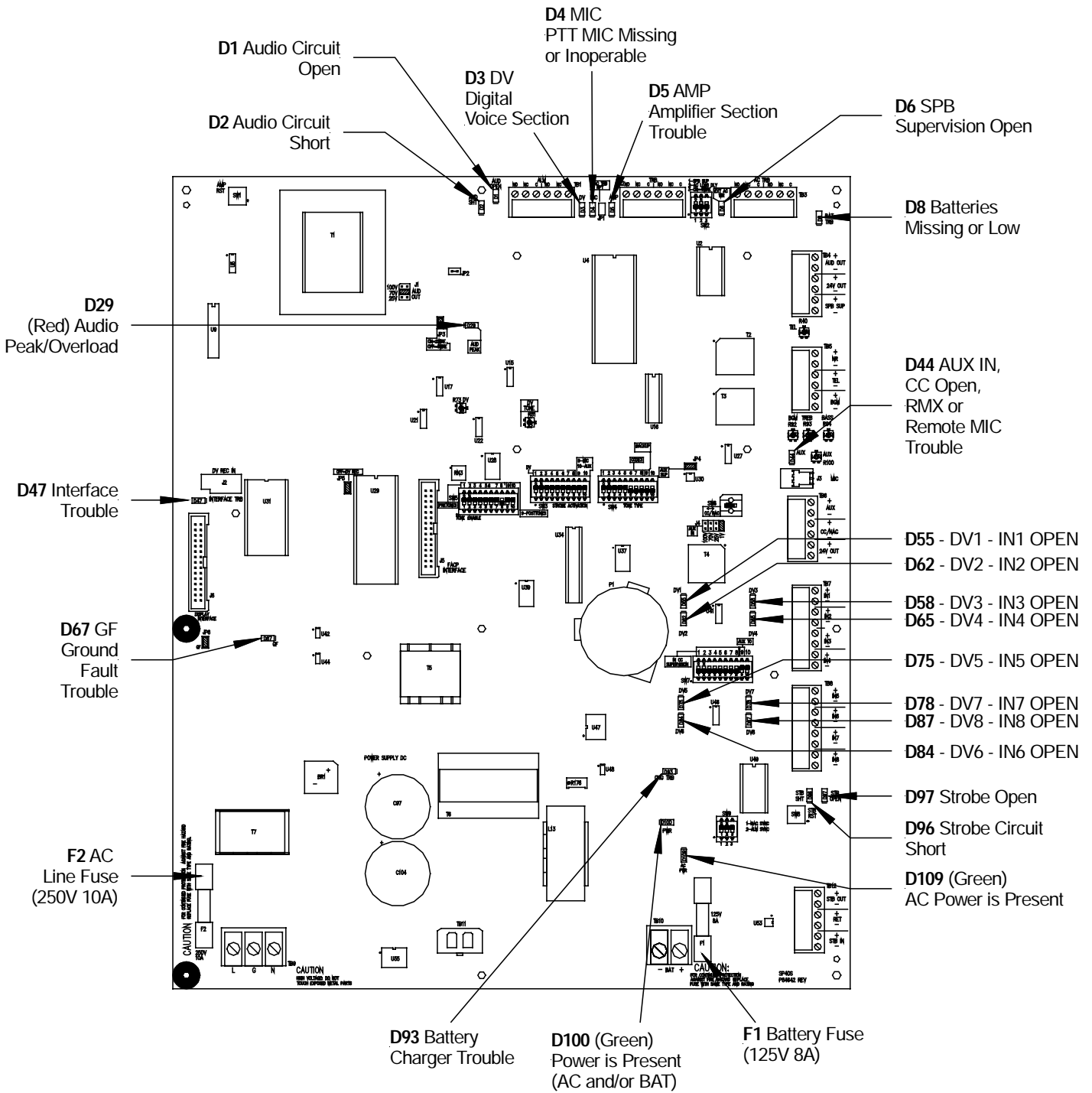

Figure 3-7 Diagnostic LEDs/Fuses

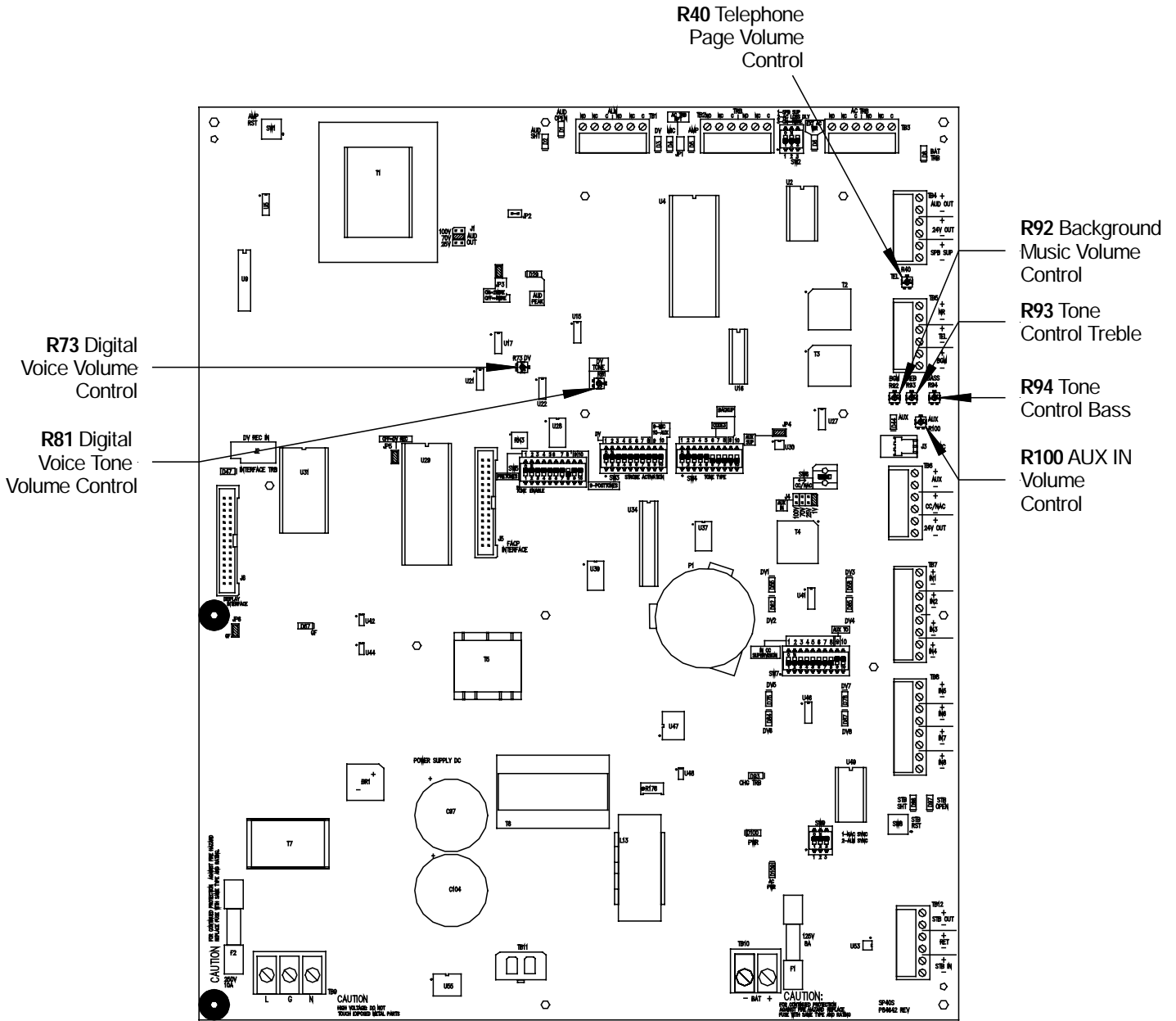

Figure 3-8 SP40S Potentiometers

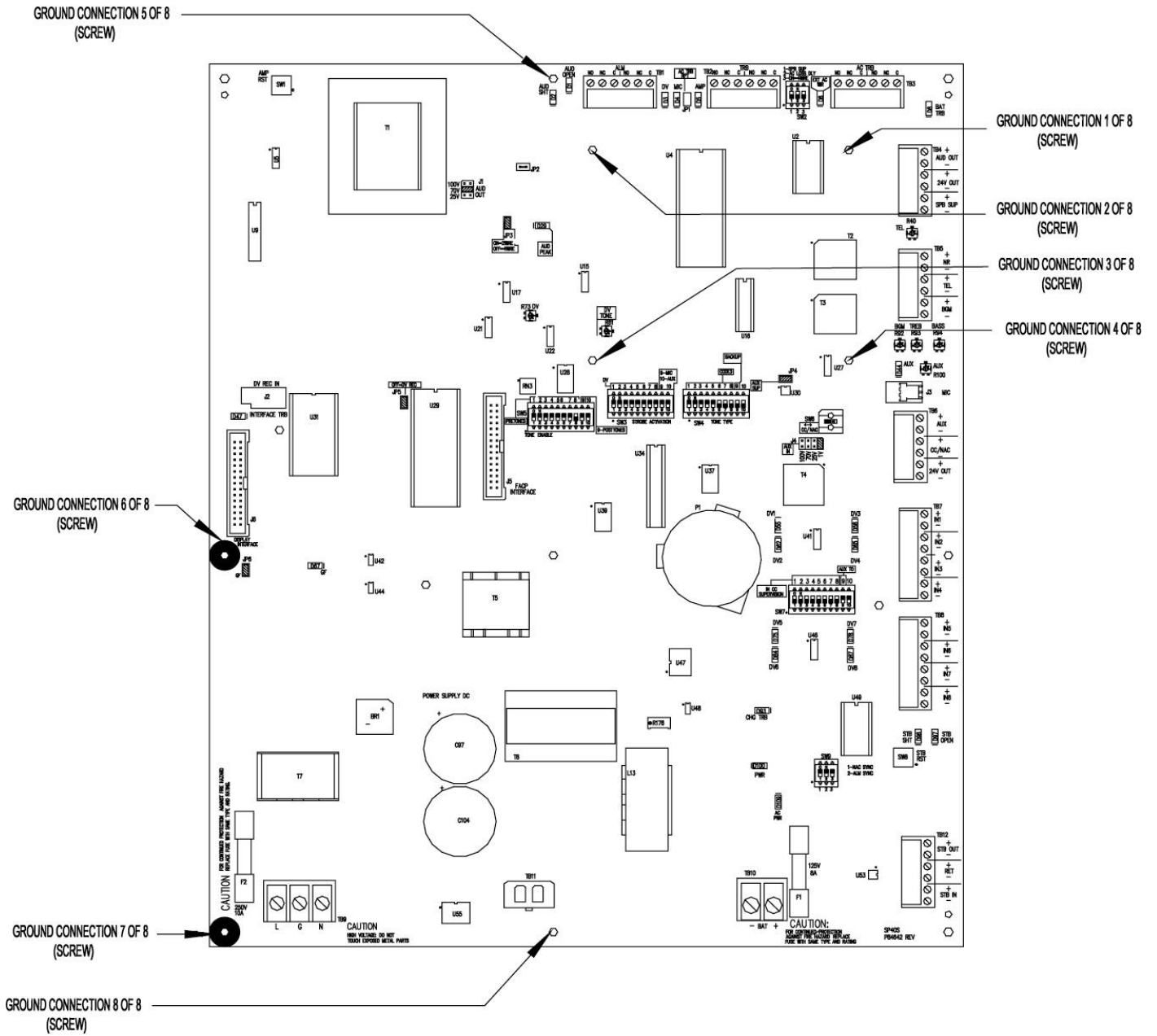

Figure 3-9 Grounding Screws and Grounding Standoff Locations

These 8 parts must be installed and securely fastened.

3.7 User Settings

3.7.1 Switch Descriptions

SW2 (AC Trouble Settings, Booster Connection Settings)		
PIN	FUNCTION	ON
1	Ext. AC Loss Sup.	10k EOLR supervision On For SPB SUP Contacts
2	AC Loss Delay	170 minute AC Loss Delay (For Off Premise AC Loss Reporting)
3	Ext AC TRB Mode	Audio Booster AC Trouble Reported To SP40S Separately

SW3 (Strobe Activation)		
PIN	FUNCTION	ON
1	DV1 Strobe	STB on when DV1 active
2	DV2 Strobe	STB on when DV2 active
3	DV3 Strobe	STB on when DV3 active
4	DV4 Strobe	STB on when DV4 active
5	DV5 Strobe	STB on when DV5 active
6	DV6 Strobe	STB on when DV6 active
7	DV7 Strobe	STB on when DV7 active
8	DV8 Strobe	STB on when DV8 active
9	MIC Strobe	STB on when MIC active
10	AUX Strobe	STB on when AUX active

SW4 (Tone Types)		
PIN	FUNCTION	ON
1	Tone Type - DV1	Code 3 (OFF = continuous)
2	Tone Type - DV2	Code 3 (OFF = continuous)
3	Tone Type - DV3	Code 3 (OFF = continuous)
4	Tone Type - DV4	Code 3 (OFF = continuous)
5	Tone Type - DV5	Code 3 (OFF = continuous)
6	Tone Type - DV6	Code 3 (OFF = continuous)
7	Tone Type - DV7	Code 3 (OFF = continuous)
8	Tone Type - DV8	Code 3 (OFF = continuous)
9	Backup tone	Code3 (OFF = slow whoop)
10	unused	--

SW5 (Pre-tone/Post-tone Enable)		
PIN	FUNCTION	ON
1	Pre-tone - DV1	Pre-tone ON for Message 1
2	Pre-tone - DV2	Pre-tone ON for Message 2
3	Pre-tone - DV3	Pre-tone ON for Message 3
4	Pre-tone - DV4	Pre-tone ON for Message 4
5	Pre-tone - DV5	Pre-tone ON for Message 5
6	Pre-tone - DV6	Pre-tone ON for Message 6
7	Pre-tone - DV7	Pre-tone ON for Message 7
8	Pre-tone - DV8	Pre-tone ON for Message 8
9	Post-tone - All	Post-tones enabled (Post-tone Matches Pre-tone)
10	Message Repeat	ON = Message plays a minimum of 3 times OFF = Message plays a minimum of 1 time*

***NOTICE TO USERS, INSTALLERS, AUTHORITIES HAVING JURISDICTIONS AND OTHER INVOLVED PARTIES:** In order for this product to comply with the requirements in the Standard for Control Units and Accessories for Fire Alarm Systems, UL 864, Position 10 of SW5 must be kept in the ON position. UL 864, 9th Edition, section 34.2.1.1 requires the alert tone/prerecorded message combination shall be repeated a minimum of 3 times.

SW6 (Initiation mode select for Aux IN)	
SETTING	DESCRIPTION
CC	Contact Closure Mode for use with RMX or SPRM
NAC	8 to 33VDC NAC Input

SW7 (DV IN Supervision and Auxiliary Timeout)		
PIN	FUNCTION	ON
1	DV MES 1 CC Supervision	10k EOLR supervision ON for IN1
2	DV MES 2 CC Supervision	10k EOLR supervision ON for IN2
3	DV MES 3 CC Supervision	10k EOLR supervision ON for IN3
4	DV MES 4 CC Supervision	10k EOLR supervision ON for IN4
5	DV MES 5 CC Supervision	10k EOLR supervision ON for IN5
6	DV MES 6 CC Supervision	10k EOLR supervision ON for IN6
7	DV MES 7 CC Supervision	10k EOLR supervision ON for IN7
8	DV MES 8 CC Supervision	10k EOLR supervision ON for IN8
9	AUX Input Timeout	Timeout active
10	unused	--

SW9		
PIN	FUNCTION	ON
1	Sync mode (NAC input)	Standard Sync (OFF = PASS THRU SYNC MODE)
2	Sync mode (Alarm)	Standard Sync (OFF = 28 volts)
3	unused	--

3.7.2 Jumper Descriptions

Jumper	Description	Additional
J1	Audio Output Level Select (25/70/100V)	
J4	AUX IN Select (1/25/70/100 V)	
J5	FACP Interface (for future use)	
J6	User Display Interface Connection	Trouble occurs if Interface is not connected
JP2	NOT USED	NOT USED
JP3	2-Wire / 4-Wire Mode	Removed = 4-Wire Mode
JP4	Contact Closure Supervision (AUX SUP)	REMOVED = CC input supervision active
JP5	DV Record	REMOVED = DV Record can be activated
JP6	NOT USED	NOT USED

3.7.3 LED Descriptions

Head	Description	Additional
D1	Audio Output Open	ON = Audio Output is open or missing EOLR
D2	Audio Output Short	ON = Audio Output is shorted
D3	DV, Digital Voice Section	ON = DV Audio is low or DV is damaged
D4	MIC, PTT MIC Missing or inoperable	ON = MIC missing or inoperable; Blinking = MIC preamp trouble
D5	AMP, Amplifier Section Trouble	ON = Amplifier trouble or audio current limiting; Blinking = AUX preamp trouble
D6	External AC Wiring trouble	ON = SPB SUP missing EOLR
D8	Battery Trouble	ON = BATT missing or low
D29	Audio Peak/Overload	ON = Audio level is too high
D44	AUX IN Trouble	ON = CC Open, RMX, or Remote MIC Trouble
D47	User Interface trouble	User Interface is improperly connected
D55	DV1 – IN1 OPEN	ON = IN1 open or missing EOLR
D58	DV3 – IN3 OPEN	ON = IN3 open or missing EOLR
D62	DV2 – IN2 OPEN	ON = IN2 open or missing EOLR
D65	DV4 – IN4 OPEN	ON = IN4 open or missing EOLR
D67	GF, Ground Fault Trouble	
D75	DV5 – IN5 OPEN	ON = IN5 open or missing EOLR
D78	DV7 – IN7 OPEN	ON = IN7 open or missing EOLR
D84	DV6 – IN6 OPEN	ON = IN6 open or missing EOLR
D87	DV8 – IN8 OPEN	ON = IN8 open or missing EOLR
D93	Battery Charger Trouble	ON = Battery charger circuit in trouble
D96	Strobe Short	ON = Short on strobe out
D97	Strobe Open	ON = Strobe out open or missing EOLR
D100	(Green) Power	ON = AC and or BAT Power is present
D109	(Green) AC Power	ON = AC Power is present

4 Installation

4.1 Introduction

Remember, the lives of people depend upon the safe and proper installation of the voice evacuation system and the SP40S Multi-Function Facility Communication System. Please read, understand, and follow the specific installation instructions set forth in this chapter carefully to avoid damage to the panel and equipment connected to it. Ensure that only qualified personnel in accordance with the procedures in this manual conduct the installation.

 **WARNING:** Shut off all power before starting the installation. Electrical shock can cause death or serious injury.

 **WARNING:** Do not connect AC power or battery backup power until system wiring has been connected, modules have been installed, and field wiring has been inspected.



CAUTION: The SP40S printed circuit board is sensitive to static electricity and has delicate components mounted on it. Before handling the board or any component on it, discharge any static electricity from your body by touching a grounded object such as a metal screw, which is connected to earth ground. Install the panel in a static-free area; properly attach grounded wrist straps before touching any static-sensitive areas.

- If you or the installer have any questions about the installation, consult with the authorities having jurisdiction (AHJ), prior to installation.

4.2 Fire Alarm Control Panel Wiring Applications

The SP40S Digital Voice Section inputs and the strobe input require an 8 to 33VDC. The Fire Alarm Control Panel (FACP) NAC Circuit of 12VDC or 24VDC initiates this circuit.

TROUBLE Form C relay terminals and an internal sounder are available for monitoring the condition of the SP40S Multi-Function Facility Communication System.

4.3 General Installation Instructions

For a view of the location of wiring connections used in the installation of the SP40S Multi-Function Facility Communication System, refer to Figure 4-1. Table 4-1 explains the functions of the different wiring connections.

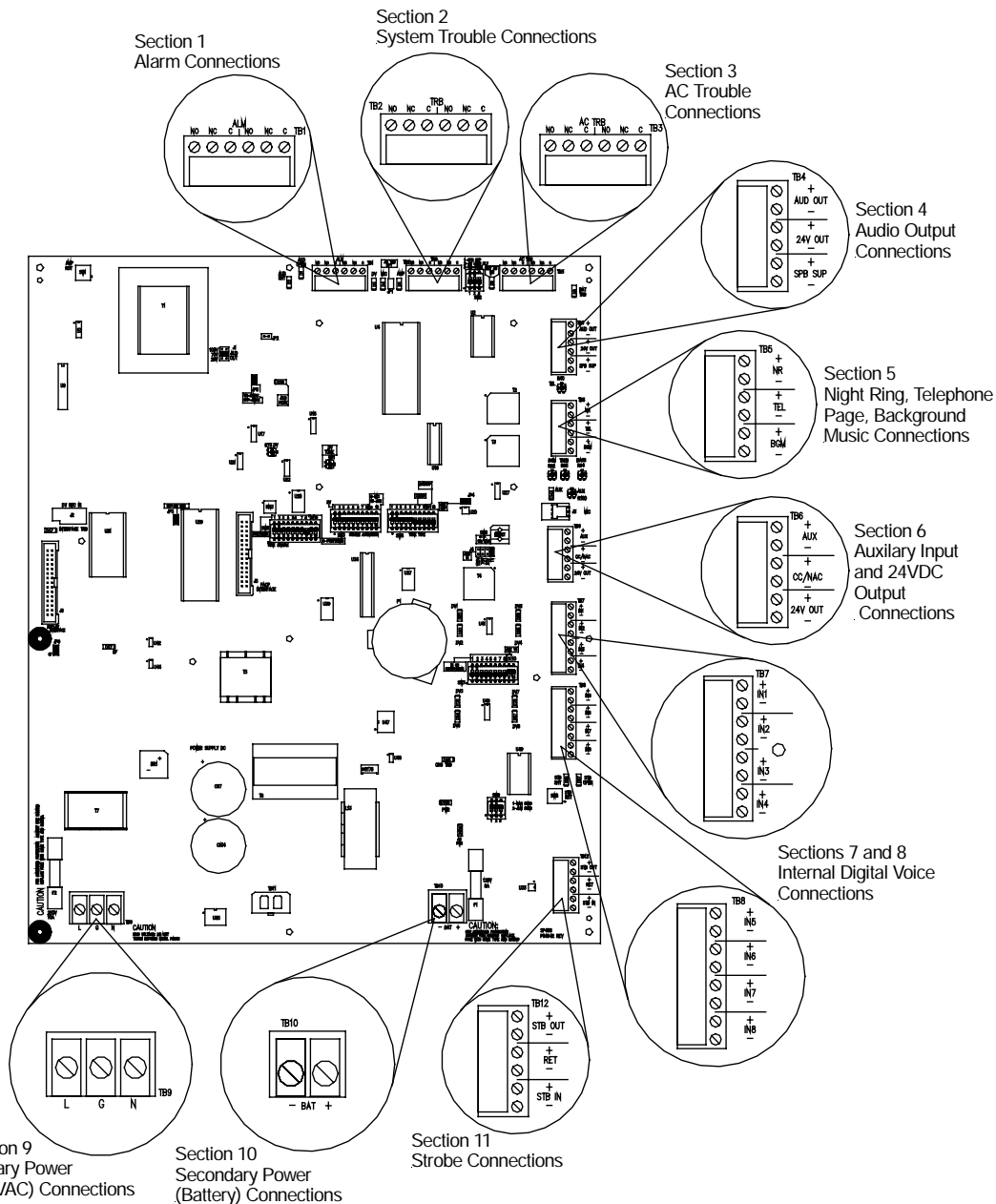

Figure 4-1 Location of Field Wiring Connections

Table 4-1. Terminal Block Connection Definitions

Terminal Block	Symbol	Alarm Connections	Definitions
TB1 Terminal Block 1 Section 1	Alarm Connections		
	ALM	Alarm connections	Alarm Form C relay changes state in Audio Alarm Conditions. These conditions are: Push-to-talk Button on MIC depressed. AUX initiated via CC or NAC, and IN1- IN8 inputs present. Contacts are rated at 24VDC, 2A. Resistive load.
	NO	Normally open	Alarm Relay contact open to Common (COM) in non-alarm condition.
	NC	Normally closed	Alarm Relay contact closed to Common (COM) in non-alarm condition.
	COM	Common	Alarm Relay Common (COM).
TB2 Terminal Block 2 Section 2	System Trouble Connections		
	TRB	System Trouble connections	Trouble Form C relay changes state in Trouble Conditions. Contacts are rated at 24VDC, 2A. Resistive load.
	NO	Normally open	Trouble Relay contact open to Common (COM) when a system trouble is NOT present.
	NC	Normally closed	Trouble Relay contact closed to Common (COM) when a system trouble is NOT present.
	COM	Common	Trouble Relay Common (COM).
TB3 Terminal Block 3 Section 3	AC Trouble Connections		
	AC TRB	AC Trouble connections	AC Trouble Form C relay changes state when primary power is missing or low. Contacts are rated at 24VDC, 2A. Resistive load.
	NO	Normally open	AC Trouble Relay contact open to common (COM) when primary power is sufficient.
	NC	Normally closed	AC Trouble Relay contact closed to common (COM) when primary power is sufficient.
	COM	Common	AC Trouble common (COM).

Terminal Block	Symbol	Alarm Connections	Definitions
TB4 Terminal Block 4 Section 4	Audio Output Connections		
	AUD OUT	Audio Output	Audio Output for 25V or 70V speakers. Supervised using UL Listed 10K Ohm, ½ W EOLR. Power Limited.
	24V OUT	24 VDC, 0.5A Output	24 VDC, 0.5A Continuous Output Connection, Power Limited auxiliary power source. NOTE: Two 24V outputs combine for 0.5A.
	SPB SUP	SAFEBAPTH4 Booster Supervision	Contact Closure indicates a primary power loss on the audio booster. Input is supervised using 10k Ohm EOLR. Used only when AC loss is reported separately from system trouble. Active only when SW2 Position 3 is ON.
TB5 Terminal Block 5 Section 5	Night Ringer, Telephone Page, Background Connections		
	NR	Night Ring	Contact Closure Input initiates chime sound for Night Ring. Non-supervised. Night Ring does not operate without 120VAC input and the Panel is operating on Battery.
	TEL	Telephone Page Input	Telephone Page Input from a telephone Page Port. Non-Supervised. Telephone Page does not operate without 120VAC input and the Panel is operating on Battery.
	BGM	Background Music Input	Line Level, 600 Ohm Background Music Input. Automatically mutes when any other input is in use. Non-Supervised. Background Music input does not operate without 120VAC input and the panel is operating on Battery
TB6 Terminal Block 6 Section 6,	Auxiliary Input and 24VDC Output Connections (For Connection To SPRM or SP4-RMX)		
	AUX	Auxiliary Input Audio	Line Level Audio Input, Remote MIC, or SP4-RMX Priority 2.
	CC/NAC	Contact Closure/NAC	Contact closure or NAC will initiate AUX IN Audio. CC is supervised. Connects to RMX or Remote MIC (CC Mode).
	24V Out	24VDC, 0.5A output	Regulated, 24 VDC, 0.5A Continuous Output Connection, Power Limited auxiliary power source. NOTE: Two 24V outputs combine for 0.5A. Connects to RMX or Remote MIC.

Terminal Block	Symbol	Alarm Connections	Definitions
TB7 Terminal Block 7 Section 7	Internal Digital Voice Module Input Connections		
	IN 1	Input 1	Digital Voice Initiating connection for message #1 (contact closure). Priority 3.
	IN 2	Input 2	Digital Voice Initiating connection for message #2 (contact closure). Priority 4.
	IN 3	Input 3	Digital Voice Initiating connection for message #3 (contact closure). Priority 5.
	IN 4	Input 4	Digital Voice Initiating connection for message #4 (contact closure). Priority 6.
TB8 Terminal Block 8 Section 8	Internal Digital Voice Module Input Connections		
	IN 5	Input 5	Digital Voice Initiating connection for message #5 (contact closure). Priority 7.
	IN 6	Input 6	Digital Voice Initiating connection for message #6 (contact closure). Priority 8.
	IN 7	Input 7	Digital Voice Initiating connection for message #7 (contact closure). Priority 9.
	IN 8	Input 8	Digital Voice Initiating connection for message #8 (contact closure). Priority 10.
TB9 Terminal Block 9 Section 9	Primary Power (120VAC) Connections		
	AC	Primary Power (AC)	AC Input Voltage. Make sure Line (L), Neutral (N), and Ground (G) are connected. Non-power limited. Make sure power cord is run properly (see wiring diagram Figure 4-13 in Section 4.9.1).
TB10 Terminal Block 10 Section 10	Secondary Power (Battery) Connections		
	BAT	Secondary Power (Battery)	24VDC, up to 33 Ah Battery input connection. The enclosure can accommodate up to 12 Ah. Batteries greater than 12 Amp-Hours (Ah) are required to be installed in a UL listed battery box. Non-power limited.
TB12 Terminal Block 12 Section 11	Strobe Connections. See Appendix E for strobe compatibility list.		
	STB OUT	Strobe Output	8-33 VDC, Regulated, 2A Maximum Strobe NAC Output Supervised with UL Listed 10k Ohm, ½ W EOLR. (Power limited).
	RET	Return	Strobe Input Return for connecting additional strobe circuits, or UL Listed 10k Ohm, ½ W EOLR.
	STB IN	Strobe Input	8-33 VDC, Strobe NAC Input. Triggers strobe in Alarm condition.

NOTE: All Outputs (Strobe Output, Audio Output, and 24VDC Auxiliary Power Source) are power limited circuits.

4.4 Preparing the System Wiring Diagram

- Keep a copy of the system-wiring diagram with the SP40S manual as a permanent record of the system wiring.

4.4.1 Unpacking and Taking Inventory

Carefully unpack the panel and make sure each item described on the packing slip is present and undamaged.

1. Check the exterior of the shipping container(s) for any exterior damage, then the interior of the container(s).
2. Notify both the carrier and Cooper Wheelock immediately on the straight bill of lading (supplied by the carrier) if any damage is found both verbally and in writing; you may also request an inspection by the carrier. Such requests must usually be made within a specified time period from date of shipment. Cooper Wheelock is not responsible for damage to equipment occurring during shipping, and only furnishes replacement parts against a written purchase order. It is the customer's responsibility to file a claim with the carrier.
3. Follow any instructions Cooper Wheelock and/or the carrier may supply about possible damage.
4. If no damage is found, compare the contents of the Inventory List against the contents of the shipping container(s), to ensure receipt of all components.
5. Save all shipping materials (any "bubble wrap" or plastic) for possible future use. Store in a safe, dry location.

4.4.2 Locating the Panel

Mount the panel in a location within the environmental limits specified in the latest UL Standard 864 for indoor/dry control panels. **DO NOT locate the panel in a hazardous area.**



CAUTION: To comply with the latest NFPA and UL requirements for interconnection of fire alarm control equipment, locate the SP40S Multi-Function Facility Communication System in the same room, and within 20 feet of, a listed compatible fire alarm control panel. Enclose the wiring in conduit and connect it properly to such control panel.

1. See Figure 4-2 for the panel mounting hole layout.
2. Mark and drill mounting holes for appropriate screws and anchors to ensure secure mounting to the type of surface at the selected location.
3. Prevent dust and dirt contamination of the SP40S Multi-Function Facility Communication System during installation. This contamination can interfere with the operation and reduce the life of the equipment.
4. Open the door and remove the dead front panel, then mount the SP40S Multi-Function Facility Communication System at the selected location. **Use care to avoid damage to the module during installation.** Do not apply excessive pressure to the PC board or its components, including field wiring terminals and connectors.

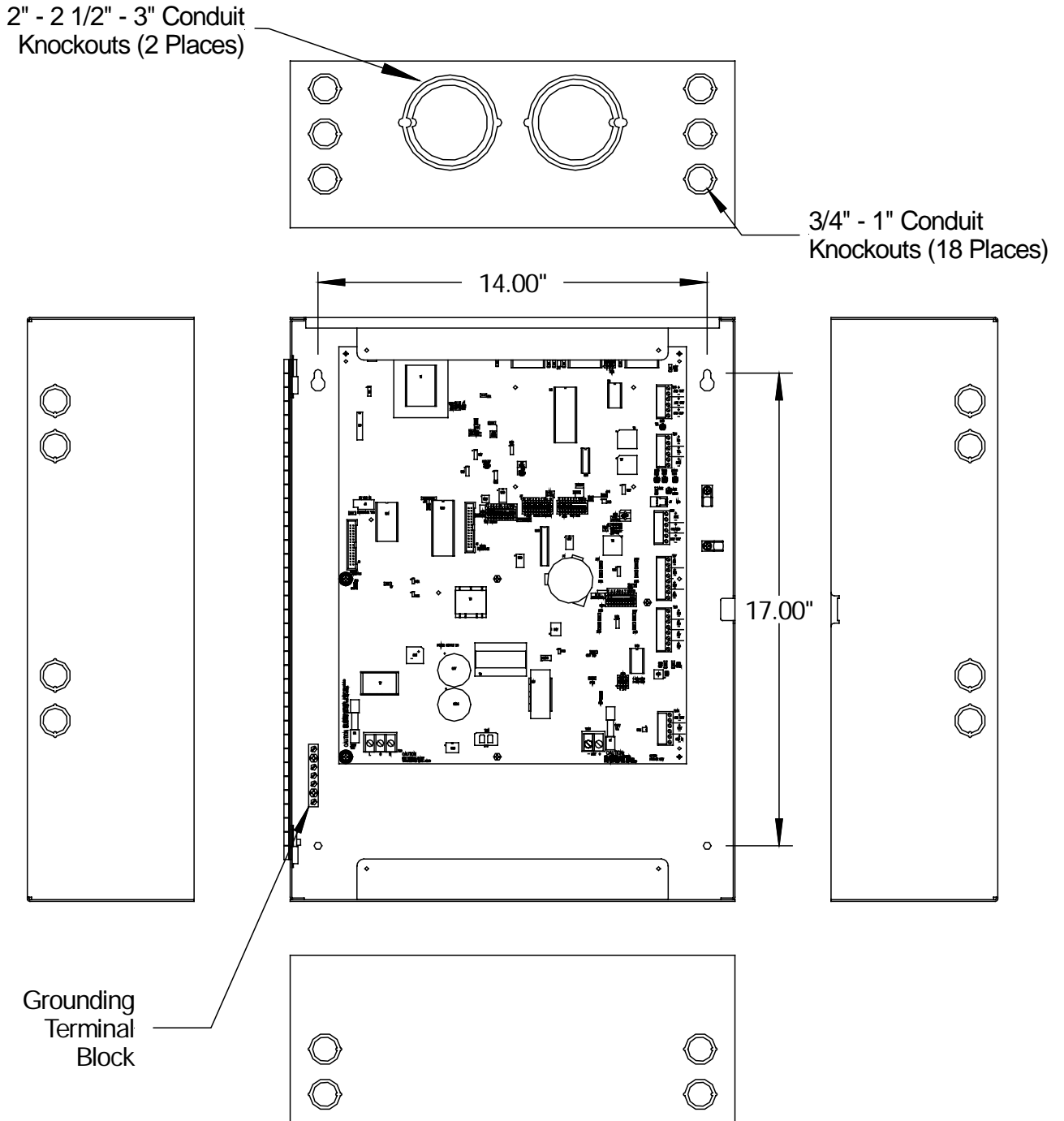

Figure 4-2 SP40S Panel Mounting and Grounding/Conduit Location



CAUTION: Use care when punching out knock-outs to avoid damage to internal components.

Wire Distance Chart For 25V Speaker Line in feet

Watts	12 AWG	14 AWG	16 AWG	18 AWG
5	2179	1374	865	543
10	1090	687	432	271
15	726	458	288	181
20	545	344	216	136
25	436	275	173	109
30	363	229	144	90
35	311	196	124	78
40	272	172	108	68

Wire Distance Chart For 70V Speaker Line in feet

Watts	12 AWG	14 AWG	16 AWG	18 AWG
5	17087	10775	6780	4256
10	8543	5387	3390	2128
15	5696	3592	2260	1419
20	4272	2694	1695	1064
25	3417	2155	1356	851
30	2848	1796	1130	709
35	2441	1539	969	608
40	2136	1347	847	532

4.4.3 Installing Field Wiring Connections

NOTE: The terminal blocks on the SP40S Multi-Function Facility Communication System are removable. To remove a terminal block, pull the block straight up from the circuit board, as shown in Figure 4-3. Attach wires to the desired connections, then plug the terminal block back on the board, being careful to match the pins.

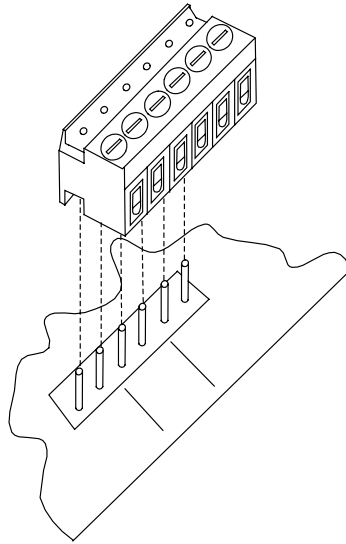

Figure 4-3 Removable Terminal Block

NOTE: For power limited circuits, make sure that all input power sources (Alarm and Trouble relay connections, NAC inputs, and auxiliary inputs) are power limited.

NOTE: The AC Power input wiring is non-power limited. Route it on the left side of the enclosure, using one of the knockouts on the left side of the enclosure. Route all power limited inputs and outputs on the right side and top of the enclosure.

Install field wiring in conduit when required, following the most current National Electrical Code (NFPA-70) and local codes for the type of system being installed. Make all necessary connections at any additional wiring or junction boxes.



CAUTION: Provide proper strain relief for all wiring not in conduit.

NOTE: Shielded wire is not required on any output circuits. If shielded wire is used, connect the shields to the ground terminal block as shown in Figure 4-2.

4.4.4 Installing Strobe Connections

The Strobe Appliance Circuit consists of a NAC (8 to 33VDC) input and supervised NAC (regulated 27VDC) output. The strobe output provides a synchronized output for compatible Cooper Wheelock, synchronized strobes. When a synchronized signal from a previous module is used, turn OFF SW9-position 1. This action also

allows for pass-through of the synchronized NAC Circuit on the RET connections. When connected with an SPB-80/4, strobe compatibility is system-wide.

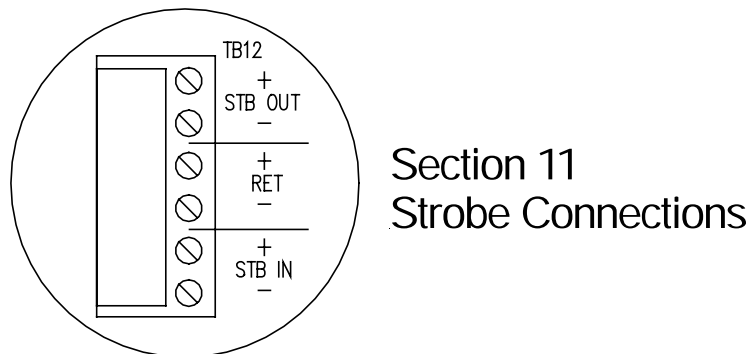

Figure 4-4 Strobe Connections

1. Connect the Strobe Appliance Circuit to the Strobe output STB OUT connection on TB12. Observe correct polarity. See Figure 4-1 for TB12's location. Figure 4-4 is an enlarged picture of the referred area. The Strobe Appliance Output Circuit is supervised. A UL Listed 10K Ohm, ½ W EOLR is required at the end of the circuit for proper supervision.

NOTE: The strobe output circuit can be activated four ways: (1) If the strobe output is to be activated during a live PTT MIC page, turn ON SW3-position 9. (2) If the strobe output is to be activated during an AUX activation, turn ON SW3-position 10. (3) If the strobe output is to be activated when one or all the digital voice messages are initiated, operate DIP switch SW9 as explained in Section 3.7.1. (4) The fourth way is to connect a NAC circuit input from an FACP to STB IN as described below.

2. Connect Strobe Circuit input (8 to 33VDC) from the FACP or other UL Listed control panels to the Strobe Input circuit (STB IN) connection on TB11. Observe correct polarity. The maximum line impedance of the strobe circuits is 40 ohms.
3. Connect the FACP EOLR, additional appliances or additional SP40S panels to RET connection on TB11.
 - The Digital Voice Initiating Connections (IN1, IN2, IN3, IN4, IN5, IN6, IN7, and IN8) can also initiate the strobe output circuit. Strobes can be initiated by the MIC, AUX, IN1, IN2, IN3, IN4, IN5, IN6, IN7, and IN8.
 - Positions 1, 2, 3, 4, 5, 6, 7, and 8 of SW3 control the strobe initiation for inputs IN1, IN2, IN3, IN4, IN5, IN6, IN7, and IN8, respectively. If positioned in the ON or UP position, the strobes operate during message playback.
 - Position 9 of SW3 in the ON position initiates the strobe circuit during a PTT MIC live announcement.
 - Position 10 of SW3 in the ON position initiates the strobe circuit during an AUX activation.
 - Position 2 (ON) of SW9 selects the Wheelock Sync Mode during an alarm strobe activation.

4.4.5 Installing Audio Output Connections

1. Connect the Audio Appliance Circuit to the Audio Output (AUDIO OUT) connection on TB4. See Figure 4-1 for TB4's location. Figure 4-5 is an enlarged picture of the referred area. The Audio Output is

supervised. A UL Listed 10K Ohm, ½ W EOLR is required at the end of the circuit for proper supervision.

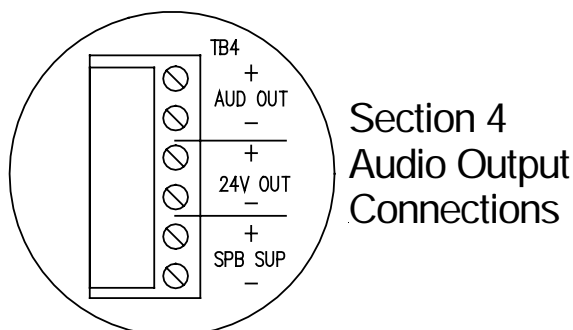

Figure 4-5 Audio Output Connections

2. Select the proper output voltage (25V or 70V) using the Audio Output Select Jumper J1.

4.4.6 Installing Auxiliary Circuit Connections

Refer to the Remote MIC or RMX Installation Manual for proper connections from 24V OUT, AUX IN, and CC/NAC to these products. All connections to these products are made from TB6.

4.4.7 Installing Audio Input Connections

The SP40S panel has thirteen inputs. The highest priority input is the on board Push-To-Talk Microphone; it overrides all other audio inputs. The second highest priority input is the AUX. This could be a Remote MIC or RMX. Next are the IN1, IN2, IN3, IN4, IN5, IN6, IN7, and IN8 respectively, followed by Night Ring (NR), Telephone Page (TEL), and Background Music (BGM). Background Music is muted when any other audio input is initiated. Night Ring (NR), Telephone Page (TEL), and Background Music (BGM) are considered non-alarm audio and operate only when the panel has 120VAC applied.

4.4.8 Installing Digital Voice Initiating Connections

The Digital Voice Initiating Connections (IN1, IN2, IN3, IN4, IN5, IN6, IN7, and IN8) provide the initiation of the stored messages in the Digital Voice Section of the SP40S panel. Each initiation circuit requires a Contact Closure input to trigger the respective voice message. Additionally, each initiating circuit is supervised for an open. A 10k Ohm, ½ W EOLR is required for each input that is supervised. If an input is not being used, supervision can be turned off via DIP switch (SW7, positions 1-8).

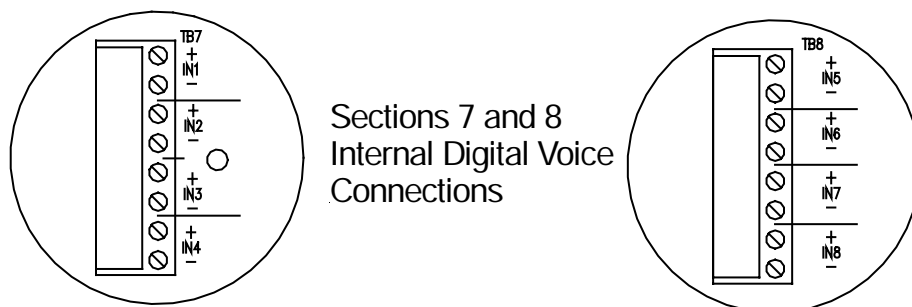

Figure 4-6 Digital Voice Initiating Connections

- While observing correct polarity, connect the Digital Voice Initiating connections (IN1, IN2, IN3, IN4, IN5, IN6, IN7, IN8) to the connections on TB7 or TB8 as desired. See Figure 4-1 for TB7 and TB8's locations. Figure 4-6 is an enlarged picture of the referred area.

4.4.9 Installing Ancillary Audio Input Connections

The SP40S panel has three ancillary audio inputs. Listed in order of priority, they are Night Ring (NR), Telephone Page (TEL), and Background Music (BGM). **These inputs do not operate when the SP40S panel is in the alarm condition or when the input voltage (120VAC) is not applied and the panel is on battery backup.** In addition, these inputs are not supervised.

The Telephone Page input requires input from a Telephone Page Port. The Night Ring input requires a dry contact closure. The Background Music input requires a line level, 600 Ohm, 1Vrms signal.

1. Connect Telephone Page Input (TEL) to TB5. See Figure 4-1 for TB5's location. Figure 4-7 is an enlarged picture of the referred area.
2. Connect Night Ring Input (NR) to TB5.

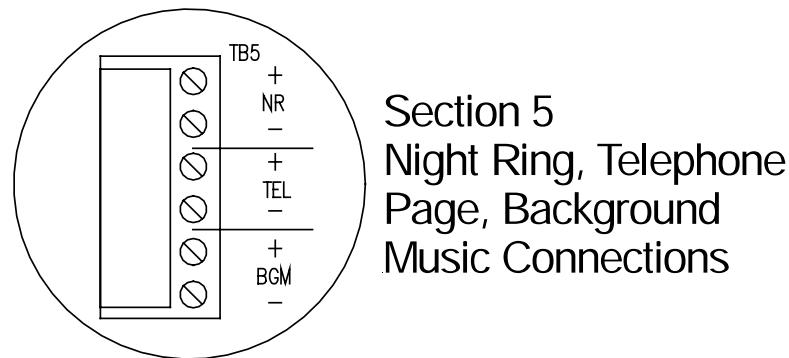



Figure 4-7 Ancillary Audio Input Connections

NOTE: The Night Ring (NR) input requires a contact closure from the phone system to activate. The NR ***must*** be connected to the phone line in the same room.

NOTE: When installed in New York City, the background music feature and telephone paging features are not permissible.

3. Connect Background Music Input (BGM) to TB5.

 **WARNING: Excessive BGM voltage input can cause amplifier failure. Make sure that the preferred audio source output for the BGM input of the SP40S panel (CD player, tuner, equalizer, etc.) is a fixed line level voltage less than 2.5v peak to peak or 300mv rms. Audio sources marked “line level output” are typically within this limit. Audio sources with other than fixed line level outputs (that is, adjustable speaker outputs, etc.) require that the audio source be adjusted using a multi-meter across the output of the signal source (see below).**

Once the level has been set properly, secure the adjustable audio source so that the level cannot be inadvertently changed. Failure to set adjustable audio sources appropriately or failure to secure audio adjustable sources can lead to failure of the amplifier section of the SP40S Panel. This failure, in turn, could result in serious injury or death to you and/or others.

4.4.10 Setting Adjustable Audio BGM Sources

NOTE: Use a good multi-meter that provides true RMS readings in the AC voltage scale and calculates the results through average sampling. Some multi-meters can select instant or average sampling readings. Always do this adjustment in the “averaging” mode. Most digital multi-meters use the average sampling method in the “AC Volts RMS” setting.

1. Ensure that power is disconnected from the SP40S panel.
2. Set the Audio Source volume control to the minimum setting.
3. Connect the Audio Source output to the BGM input terminals (TB5) on the panel.
4. Set the multi-meter to the AC Volts scale, which is capable of reading 300mV RMS.
5. Connect the multi-meter across the BGM terminals on the panel.
6. Adjust the output control of the audio source to obtain a reading of 300mV RMS on the multi-meter.
7. Secure the output control of the audio source so that it cannot be changed inadvertently.
8. Disconnect the multi-meter. The output of the Audio Source is now correctly set for the SP40S BGM input.

4.4.11 Installing Alarm, System Trouble, and AC Trouble Output Connections

The Alarm Form C relay contacts change state when a MIC, AUX, or a DV (Digital Voice) message is active. The AC Trouble Form C relay contacts change when primary power is missing or low. The System Trouble Form C relay contacts change state when the panel goes into any trouble condition. For additional information, see Table 4-1. An AC Loss can be delayed 170 minutes before it is reported as a system trouble (SW2 – Position 2 set to ON).

1. Connect the external alarm circuit to the proper Alarm (ALM) connections. See Figure 4-1, TB1, Section 1, for location.
2. Connect the external Trouble circuit to the proper Trouble (TRB) connections.
3. Connect the SP40S panel to earth ground, following the National Electrical Code and local codes for the type of system being installed. Wire gauge selection of the earth ground wiring involves consideration of all factors, including maximum allowable wire resistance and length. The panel is tied to earth ground by connecting the ground terminals to an earth ground. The location of the ground terminals within the panel is shown in Figure 4-2.



CAUTION: Do not connect input voltage to any equipment until the field wiring has been tested, inspected and approved.

4. Check the integrity of all field wiring. Confirm that the specified cable is installed, and that there is continuity between required points (no open circuits), with no unwanted shorts to other conductors, chassis, or earth ground.
 - a) Verify that the field wiring complies with the instructions of this manual and the detailed wiring diagram prepared for this installation.
 - b) Ensure that no unwanted voltages are present on circuit conductors and ground.
 - c) Test all ungrounded connectors for electrical isolation from ground.
 - d) Measure and record the resistance of each NAC circuit. Conduct this test reversing polarity.
5. Perform Ground Fault Installation procedure as described in Section 4.7.
6. Calculate and install properly sized backup batteries as described in Section 4.8.3. The SP40S panel is UL approved for 24VDC for a maximum of 33 Ah. Batteries greater than 12 Amp-Hour (Ah) are required to be installed in a UL listed battery box. The enclosure can accommodate up to 12 Ah.



WARNING: Two different sources of power should be connected to this unit. Disconnect both sources of power before servicing. Failure to disconnect both power sources before servicing could result in serious injury, or death to you and/or others.



WARNING: Always apply AC voltage before applying battery backup voltage. Failure to do so may cause damage to the SP40S panel.

7. Perform System Checkout procedures as described in Section 4.6.

4.5 Wiring the System

4.5.1 Wiring Guidelines

Although the SP40S panel incorporates signal verification and noise filtering circuitry on its inputs, induced voltages or noise on the input wiring can cause improper operation. Therefore, use shielded twisted pair wire for all dry contact input wiring.

- Connect the shield of each cable only at one end.
- Connect each shield of each cable that connects to the panel to the grounding points provided near the knockout locations on the chassis (see Figure 4-2).

The National Electrical Code defines two types of circuits for protective signaling systems: power limited circuits and non-power limited circuits. All outputs (STB OUT, AUDIO OUT, and ± 24 VDC auxiliary power source) are power-limited circuits.

 **WARNING: Route all SP40S Multi-Function Facility Communication System audio wiring away from any high voltage or high current wiring (such as AC or DC power wiring, audio power wiring, and motor or relay actuation wiring). Failure to do so may cause electrical shock, resulting in serious injury or death to you and/or others.**



CAUTION: The National Electric Code limits the maximum number of conductors that can be installed in conduit and wiring boxes depending on the size of the conduit, the volume of the boxes, and the gauge of the wire used. Make sure that wiring used for SP40S installation complies with the latest NEC, NFPA, Local, State, County, or Province requirements.

4.5.2 Field Wiring Connections

All SP40S wiring terminals are designed to accept #12 AWG through #18 AWG wiring for one wire per terminal or #16 AWG to #18 AWG for two wires per terminal. Proper wire gauge considerations for the Notification Circuit must take into account current requirements versus length of run.

NOTE: Only speakers with DC blocking capacitors provide for proper speaker supervision.

4.5.3 Preparing a System Wiring Diagram

Prepare a system-wiring diagram to include all Notification Appliances, and internal connections and power sources as required.

NOTE: Separate the AC input power wiring from the other input and output wiring. Wire the AC input power to the left side of the motherboard (Figure 4-13) and the other input and output wiring to the right.

4.5.4 Visual Notification Appliance Output Wiring

Wire gauge selection involves consideration of all factors including, wire loop length, maximum current draw of each appliance, number of appliances, and maximum voltage drop allowable.

- Strobe NAC has a regulated 24VDC, 2.0 Amps maximum output.
- Strobe NAC meets Class B supervision requirements for notification appliance circuits.
- For the strobe output circuit, install a UL Listed 10K Ohm, ½ W EOLR across the last visual notification appliance. If the output is unused, place a UL Listed 10K Ohm, ½ W EOLR across the output terminals.

4.5.5 Speaker Notification Appliance Output Wiring

Wire gauge may vary for each audio appliance output on the panel. When:

- Speaker (with transformer) appliances are used with supervised audio amplifier module. Wire gauge selection involves consideration of all factors including, wire length, appliance power ratings, and the number of appliances.
- The amplified output is either a selectable 25 or 70.7Vrms audio output, rated for 40 watts maximum.
- The output meets Class B supervision requirements for notification appliance circuits.
- To meet Class A requirements, a Cooper Wheelock splitter (SP4-A/B or SP4-APS) is required.
- For the audio output circuit, install a UL Listed 10K Ohm, ½ W EOLR installed across the last notification appliance. If the output is unused, place a UL Listed 10K Ohm, ½ W EOLR across the output terminals.

4.5.6 Wiring Diagrams for Audio/Visual Notification Appliances

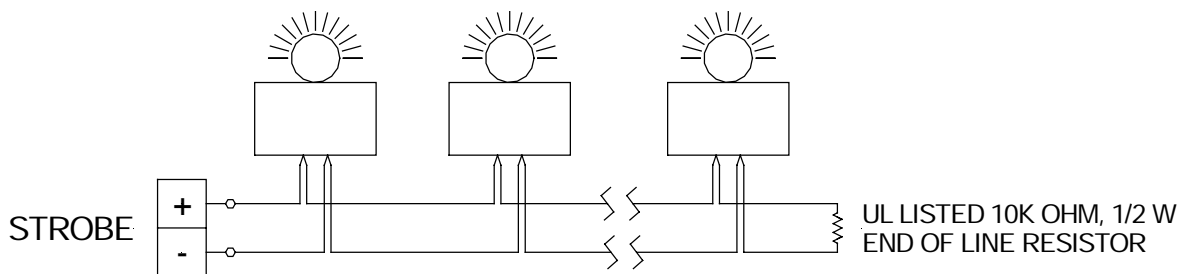

Figure 4-8 Wiring Diagram for Visual Only Notification Appliances



CAUTION: Do not loop wire under terminals. Break wire run to provide supervision of the connection.

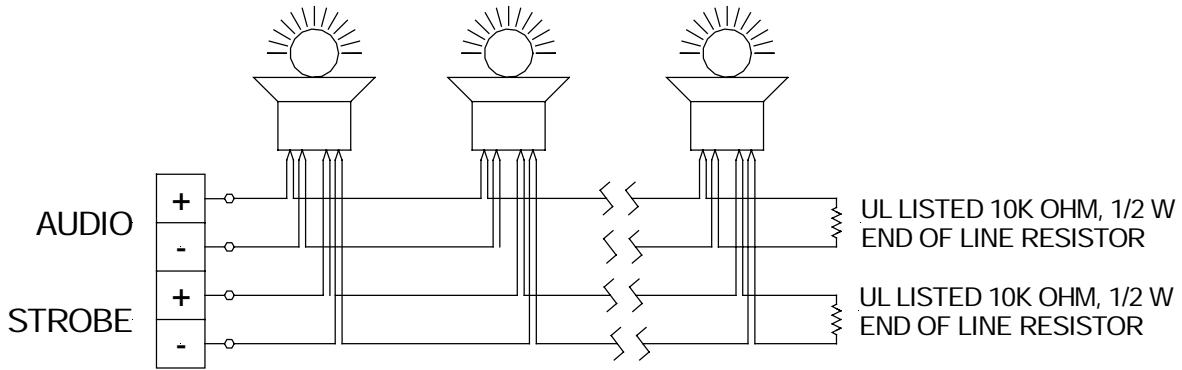

Figure 4-9 Wiring Diagram for Combination Audio/Visual Notification Appliances



CAUTION: Do not loop wire under terminals. Break wire run to provide supervision of the connection.

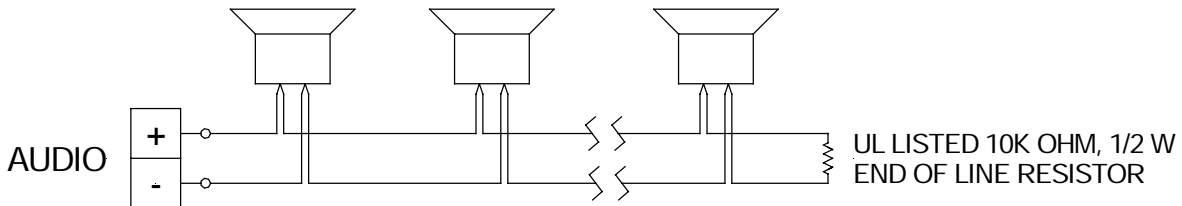

Figure 4-10 Wiring Diagram for Audio Only Notification Appliance Output



CAUTION: Do not loop wire under terminals. Break wire run to provide supervision of the connection.

4.5.7 Wiring the Alarm Output Contact

The location of the Alarm Output Connections (TB1) is shown in Figure 4-1. A magnified view of this area on the motherboard is shown in Figure 4-11.

- Wire gauge selection of the Alarm Status output contact wiring involves consideration of all factors including, wire loop length, maximum current capacity, and maximum voltage drop allowable.
- The Alarm Status output contact is Form C, rated for 2.0 amps at 24VDC, resistive load.
- For terminal connection details of the Alarm Status output contact (shown in the non-alarm mode), see Figure 4-11.
- Contacts are duplicated for ease of IN and OUT wiring.
- An external 24VDC or the internal 24VDC connection (TB1) can be used to power non-supervised Alarm appliances.

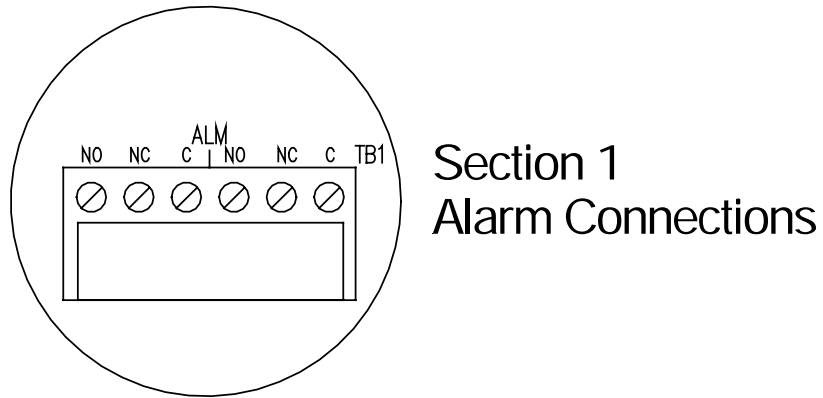

Section 1 Alarm Connections

Figure 4-11 Alarm Connections

4.5.8 Wiring the System Trouble Connections

The locations of the System Trouble (Trouble Status Output) Connections (TB2) are shown in Figure 4-1. A magnified view of this area on the motherboard is shown in Figure 4-12.

- Wire gauge selection of the system Trouble Status output contact wiring involves consideration of all factors including, wire length, maximum current capacity, and maximum voltage drop allowable.
- The system Trouble Status output contact is Form C, rated for 2.0 amps at 24VDC, resistive load.
- For a detail of the system Trouble Status output contact terminal connections (shown in the trouble position), see Figure 4-12 below.
- An external 24VDC or the internal 24VDC connection (TB1) can be used to power Trouble indicating appliances.

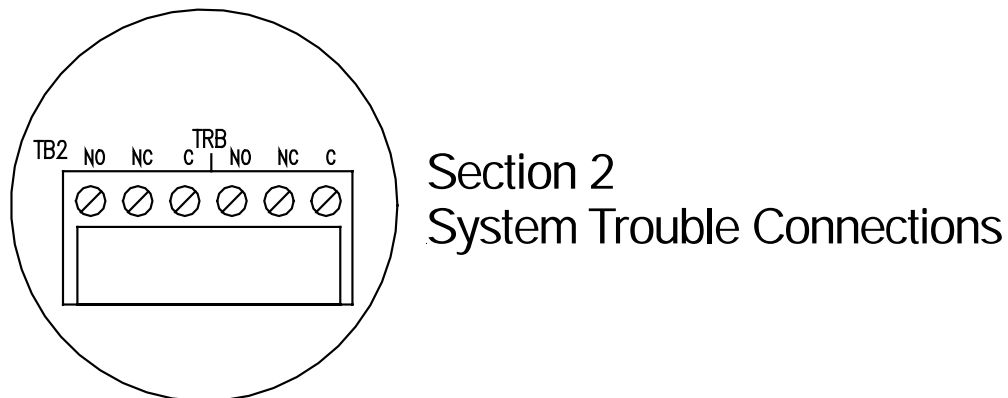

Section 2 System Trouble Connections

**Figure 4-12 System Trouble Connections
(Trouble Status Relay Contact)**

4.6 Performing System Checkout

For guidelines on testing notification systems, refer to the latest NFPA 72 code.

4.6.1 System Control Settings

Figures 3-4 thru 3-8 show the location of the controls used to configure the SP40S Multi-Function Facility Communication System. Table 4-1 identifies and explains the functions of the terminal blocks, Section 3.7 the other user settings. The following procedure is a basic setup for the panel.

1. Ensure that the AC and Battery Power are not connected.
2. Plug in the microphone.
3. Select the proper audio output (25V or 70V) on J1 Audio Output Select.
4. Connect the speaker circuit(s) to terminal block TB4 AUD OUT. Verify that the speaker circuit has a UL Listed 10K Ohm, ½ W EOLR.
5. If applicable, connect the strobe circuit to TB12 STB OUT. Verify that the strobe circuit has a UL Listed 10K Ohm, ½ W EOLR.
6. If Strobe synchronization is to be defeated, turn OFF positions 1 and 2 of SW9 Strobe Synchronization Defeat.

4.6.2 Checkout Procedure

⚠ WARNING: Always connect the AC power source before connecting the battery backup power. Always disconnect the AC power source before disconnecting the battery backup power.

NOTE: All terminal blocks, jumpers, switches, LEDs, Fuses, and Potentiometers are illustrated in Figures 3-4 thru 3-8.

- Connect the interface ribbon cable to J6.
- Connect AC power, then connect the batteries.

When the AC power source is applied to the panel, the battery voltage check circuitry is activated. If batteries are not connected within 20 seconds, the panel trouble circuit activates. The battery voltage check circuitry re-checks for batteries every two minutes. If the batteries are installed during the two-minute period, the panel remains in trouble mode until the next re-check.

- **D100 PWR LED and POWER ON (Interface) LED should be “ON” to indicate normal operation.**
- If SYSTEM TROUBLE (Interface) LED (Yellow) is “ON,” and the internal sounder is operating, a trouble condition is indicated.
- In such a case, STOP TESTING. Refer to Chapter 8 of this manual, then troubleshoot and correct the problem before you resume testing. See Figures 3-7 for location of LEDs.

- Perform the following tests:

4.6.2.A Microphone Test

1. Press the **push-to-talk** Button on the microphone and speak into the microphone.
2. Ensure your voice can be heard on the output speaker circuit.

4.6.2.B Auxiliary Test

1. If a Remote MIC or RMX is being used, initiate a Remote MIC and speak into the microphone.
2. Ensure your voice can be heard on the output speaker circuit.

4.6.2.C Digital Voice Message Test

Message 1

1. Press the top message button. The message should be heard on output speaker circuit. The top message button/LED on the interface should blink to indicate the button has been pressed.
2. Test the strobe circuit associated with the first message by switching DIP switch SW3 (DV/Strobe Select), position 1 “ON.” The STB LED on the interface (Red) turns “ON.” If the strobe circuit is attached to TB11, strobos flash.
3. Turn OFF message 1 by pressing the top message button again or removing contact closure from IN1. The message plays to completion at least three times. If DIP switch SW2 (DV/Strobe Select) position 1 is ON, the strobe circuit is ON until the message is complete.
4. Turn DIP switch SW3, position 1 OFF.
5. Apply contact closure activation to TB7 (IN1) connection (Figure 4-6). The message should be heard from output speaker circuit. The top message button/LED on the interface should illuminate steadily to indicate contact closure is present.
6. Test the strobe circuit associated with the first message switching DIP switch SW3 (DV/Strobe Select), position 1 “ON.” The STB LED (Red) turns “ON.” If the strobe circuit is attached to TB2, strobos flash.
7. Remove the contact closure from TB7 (IN1). The message plays to completion at least three times. If DIP switch SW3 (DV/Strobe Select) position 1 is “ON,” the strobe circuit is ON until the message is complete. The top message button/LED on the interface should turn OFF once the contact closure is removed.
8. Turn DIP switch SW3, position 1 OFF.
9. Perform Steps 3 through 10 on Messages 2 and 3. Use Table 4-2.

Table 4-2. Digital Voice Message Tests

Message Number	TB4	Interface Button	SW3 DV/Strobe Select
Message 1	IN1	Top	Position 1
Message 2	IN2	Second	Position 2
Message 3	IN3	Third	Position 3
Message 4	IN4	Fourth	Position 4
Message 5	IN5	Fifth	Position 5
Message 6	IN6	Sixth	Position 6
Message 7	IN7	Seventh	Position 7
Message 8	IN8	Eighth	Position 8

4.6.2.D Strobe Circuit Test

1. If the Strobe circuit is being used separately, apply 24VDC from TB4 or TB6 to STB IN connection TB12 (Figure 4-4). The Strobes on the Strobe Output Circuit should flash. Also, the SP40 interface Strobe Active LED should illuminate.
2. Remove the voltage.

4.6.2.E Night Ring Test

Test Night Ring by shorting NR connection TB5 (Figure 4-7). The chime sound should be heard from the output speaker circuit.

4.6.2.F Telephone Page Test

If the Telephone Page circuit is used, make a telephone page from the phone system. The page should be heard from the AUDIO OUT speaker circuit.

4.6.2.G Background Music Test

1. If the Background Music (BGM) circuit is used, energize the music source. The music source output should be heard from the output speaker circuit. The Installation and Checkout procedure is now complete.
2. Make and check final connections, then replace the dead front panel.

⚠ WARNING: Perform mandatory testing of all protective signaling systems as required. Test all protective signaling system equipment using qualified personnel at least twice a year for proper operation, or more often if required by codes, regulations, and laws. Failure to maintain and test protective signaling system equipment can result in not detecting equipment failure that can cause serious personal injury or death to you and/or others during an emergency situation.

4.7 Ground Fault Detection

Ground fault detection sensitivity is a minimum of 40K Ohms for Class B, Style Y connections.

4.8 Battery Care and Backup Battery Calculations

4.8.1 Caring for Sealed Lead Acid Batteries

Sealed lead acid batteries are designed to operate in standby service for approximately five years. This is based upon a normal service condition where there is an ambient temperature of 20 degrees C (68 degrees F) and batteries are completely discharged once every three months. **Length of service life is directly affected by the number of discharge cycles, depth of discharge, and ambient temperature.**

Use Guidelines

- Avoid installation and/or operation in close proximity to heat sources. While the operating temperature range is 0 to 49 degrees C (32-120 degrees F), battery life is maximized at an ambient temperature of 20 degrees C (68 degrees F).
- Batteries may generate ignitable gases. Because of this, install batteries in a well-ventilated location, away from spark producing equipment.
- DO NOT install batteries in an atmosphere where organic solvents or adhesives may be present. DO NOT clean the batteries with oils, thinners, or similar substances. The case and cover of the batteries are ABS plastic resin, which may suffer damage from these chemicals.
- DO NOT install batteries in a heavy vibration or shock location.
- ALWAYS wear insulated gloves when handling batteries.
- DO NOT use together batteries of different capacities, age, or manufacture.

 **WARNING: DO NOT crush, incinerate, or dismantle batteries. The electrolyte contains sulfuric acid, which can cause serious damage to eyes and skin. If contact does occur, flush with water and seek immediate medical attention.**

4.8.2 Storing Batteries

- For batteries that are to be stored for an extended period of time, give a supplemental charge monthly.
- NEVER store batteries in a discharged condition.
- The self-discharge rate of batteries is approximately 3% per month when the storage temperature is maintained at 20 degrees C (68 degrees F). The self-discharge rate varies depending upon temperature. Cooler temperatures cause the self-discharge rate to decrease. Warmer temperatures cause the self-discharge rate to increase.

4.8.3 Calculating Backup Battery Requirements

A Worksheet for assisting in calculating battery backup is available in Chapter 11.

Due to the current drain on the battery, the maximum battery size for the SP40S Multi-Function Facility Communication System is 33 Amp-Hours (Ah). The enclosure can accommodate up to 12 Ah. Batteries greater than 12 Amp-Hours (Ah) are required to be installed in a UL listed battery box.

It is necessary to calculate the current draw for battery backup requirement. The current requirement depends on the system configuration and the appliances connected to the Speaker output circuits. Battery Backup current has two separate calculations that are added together: Standby Current and Alarm Current.

4.8.3.A Standby Current

The Standby Current consumes the largest part of the storage battery capacity. The Standby Current of the SP40S Multi-Function Facility Communication System is 0.130 Amps. Multiply this value by the number of standby hours required. Normally this is 24 hours. This represents the total Standby current in Amp-Hours for the panel.

4.8.3.B Alarm Current

The maximum Alarm Current for the SP40S Multi-Function Facility Communication System is 4.70 Amps (1.6 Amps for audio, 2.0 Amps for strobe, and 0.5 Amps for auxiliary power).

1. Calculate the strobe output current by adding the current draw of all strobes. Current draw is in Amps.
2. Calculate speaker output current by totaling all the speaker wattage settings. Multiply the sum by 0.040. The result is the current draw in Amps.
3. Add the strobe current, the speaker current, and auxiliary current together. The result is the total Alarm Current in Amps.

Alarm circuits are required to operate for 15 minutes on battery power. Multiply Step 3 by 0.25 hrs. The result is the total Alarm Capacity Required in Amp-Hours.

4.8.3.C Battery Calculations

Good engineering practices recommend the total Amp-hours required for backup should not exceed 90% of the Backup Battery capacity. The SP40S Multi-Function Facility Communication System has been UL approved for a maximum of 33 Ah batteries. The enclosure can accommodate up to 12 Ah. Batteries greater than 12 Amp-Hours (Ah) are required to be installed in a UL listed battery box.

1. Add the total Standby Capacity Required to the total Alarm Capacity Required.
2. Multiply Step 1 by 1.25. This is the minimum Backup Battery requirement for this panel.
3. Record results on worksheet.

4.9 Installing AC Power and Batteries

NOTE: Power-limited and non-power limited wiring **must** be separated. Wire non-power limited wiring (AC power and battery) to the left of the motherboard. Wire power limited wiring to the right and top of the motherboard.

⚠ WARNING: Two different sources of power should be connected to this unit. Disconnect both sources of power before servicing. Failure to disconnect both power sources before servicing could result in serious injury or death to you and/or others.



CAUTION: Observe correct polarity requirements on all connections. Failure to do so may damage the equipment.



CAUTION: Always apply AC voltage before applying battery backup voltage. Failure to do so may cause damage to the SP40S Multi-Function Facility Communication System.

4.9.1 Installing AC Power

1. Refer to Figure 4-13) and connect the line and neutral 120VAC input wiring to the L (Line) and N (Neutral) terminals on the terminal block TB9 (see Figure 4-1 for location) in the lower left corner of the chassis.
2. Ensure that the ground input wiring is connected to the ground terminal (TB9) on the left side of the chassis.
3. Secure the wire with the caps nut located in the hardware package.

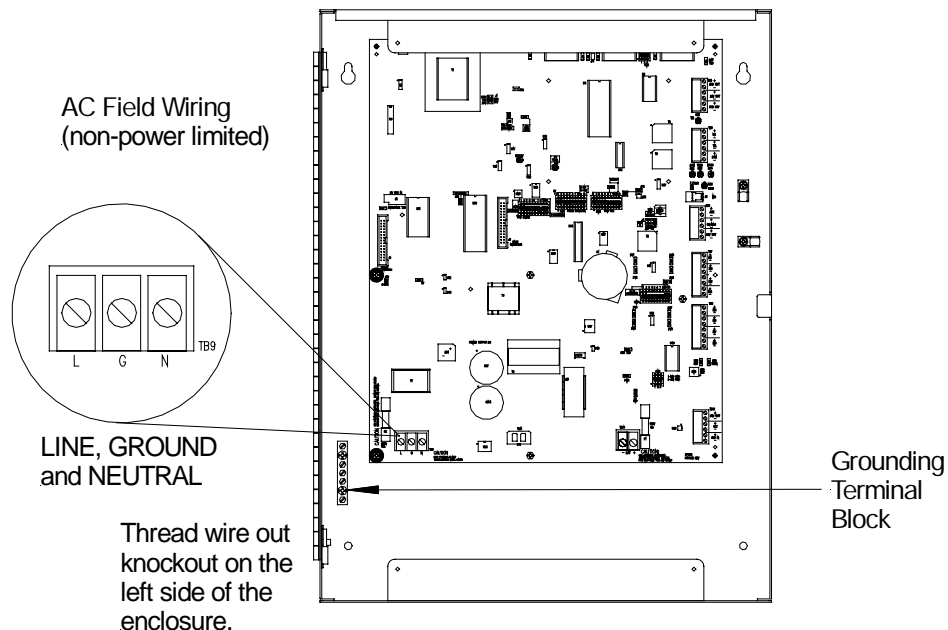

Figure 4-13 120VAC Input Connection

4.9.2 Installing Batteries

NOTE: Batteries are not supplied with the SP40S Multi-Function Facility Communication System and must be purchased separately.

1. Connect the supplied red battery wire to the (+) terminal and the supplied black battery wire to the (-) terminal of TB10 (see Figure 4-14).
2. Run jumpers along the bottom of the chassis in the battery compartment.

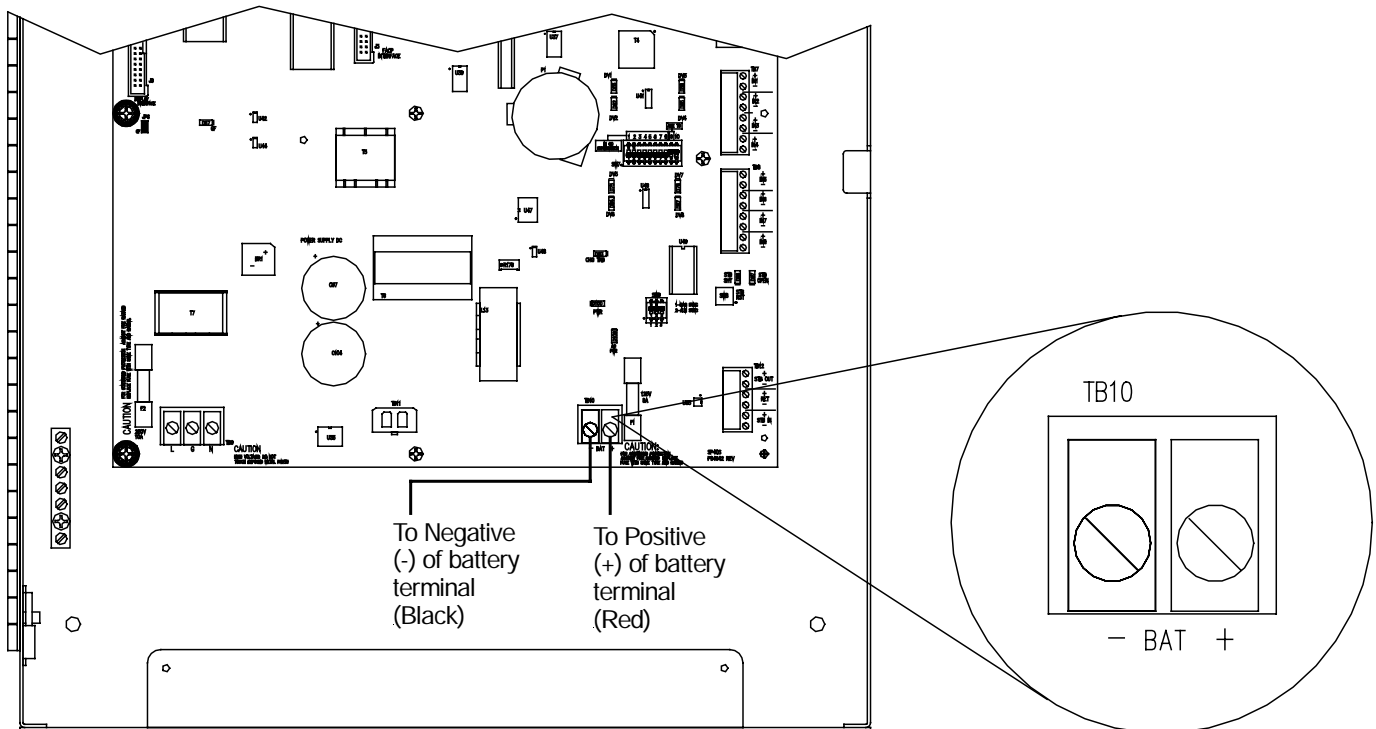

Figure 4-14 Battery Wire Connections

3. Refer to Figure 4-15 and place one 12-Volt battery with the battery terminals on top and to the right. Place the second battery to the right of the first battery with the battery terminals on top and to the left.



CAUTION: Always install the two batteries with the battery terminals pointing to the center and in the upright position as shown in Figure 4-15. Failure to do so may cause a short circuit which may damage the SP40S panel or batteries and cause the panel to fail to operate in an emergency condition.

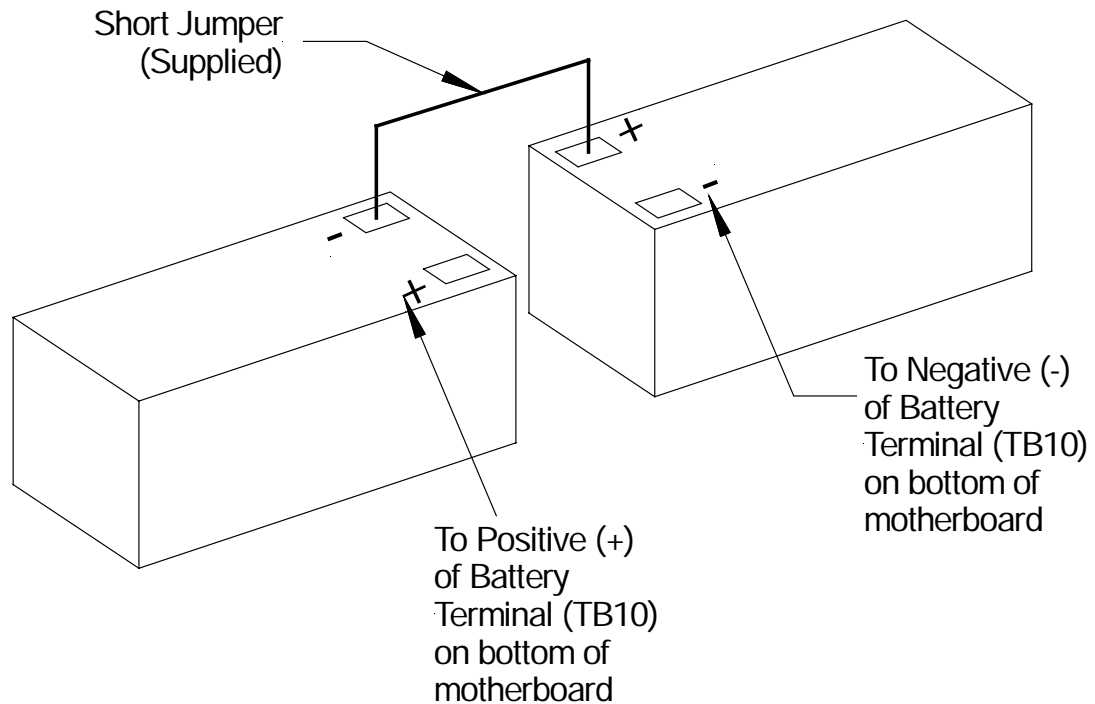

Figure 4-15 Battery Alignment and Jumper Connection

4. Connect the short jumper (included) to the back terminals (negative to positive) of the two batteries as shown in Figure 4-15. This connects the 12VDC batteries in series in order to produce 24VDC.
5. Place the batteries in the battery compartment with the battery terminals and jumper facing “UP” or toward the top of the SP40S panel. Make sure that the red and black battery jumpers are clear of the batteries.
6. Attach the red and black battery wires (red to (+), black to (-)) to the proper battery terminals.

5 Operation

5.1 Introduction

This chapter describes the operating characteristics of the SP40S Multi-Function Facility Communication System. Included is information about the following panel features:

- Supervision
- Audio Notification Appliance Output Circuit Supervision
- Amplifier Supervision
- Actions that Initiate Alarms

5.2 User Interface

The User Interface on the SP40S displays the basic status of the unit as well as providing a limited number of user controls. The User Interface includes a Microphone and the manual activation or recording of the eight messages. There is also a button to silence the audible trouble indicator. Status indicators include POWER ON, SYSTEM TROUBLE, AC TROUBLE, ALARM ACTIVE, and STROBE ACTIVE (see Figure 3-3).

5.3 Supervision

A SYSTEM TROUBLE LED indicates that the supervisory functions have detected a malfunction in the panel. When a trouble condition is detected, the panel may not be able to receive and/or broadcast messages from the control panel.

If a trouble condition is detected by any of the supervisory functions, the internal sounder operates the panel Form C TROUBLE relay (normally energized), changes state, and the yellow SYSTEM TROUBLE LED turns "ON." The Trouble Status Relay (TB2) must be properly connected to and used by the control panel to indicate a system trouble. At the same time, one of the yellow trouble location LEDs identifies the location of the trouble condition. The internal sounder can be silenced for 20 hours by depressing the "Trouble Acknowledge" Switch (SW1, on the User Interface). Any subsequent troubles cause the sounder to be re-activated. If a trouble condition is indicated, follow the procedures in Chapter 8 "Troubleshooting."

An AC Loss can be selected to be reported as a system trouble after 170 minutes (SW2-Position 2 = ON). This is desirable for off-premise trouble reporting. If SW2-Position 2 is OFF, AC Loss is reported as a system trouble after 30 seconds.

 **WARNING: Do not leave the SP40S panel in a trouble condition, as it may not play warning messages, which could result in serious injury or death to you and/or others. If the panel indicates a trouble condition: (1) provide UL required alternative signaling and (2) have qualified service persons immediately replace unit(s) that have malfunctioned.**

 **WARNING: Messages requested before and during a trouble condition may not be heard, which could result in serious injury or death to you and/or others. If messages requested before and during a trouble condition are still necessary, repeat them when the SP40S panel is returned to normal.**

5.3.1 Visual Notification Appliance Output Circuit Supervision

The Visual Notification Appliance Output Circuit uses Class B, Style Y wiring, and is supervised for open and short circuits when the output is de-energized. Output circuit supervision requires installation of UL Listed 10K Ohm, ½ W EOLR on the output circuit. A sensed strobe short circuit trouble illuminates D96 STB SHORT LED. A sensed strobe open circuit trouble illuminates D97 STB OPEN LED. See Figure 8-1 for LED location.

5.3.2 Audio Notification Appliance Output Circuit Supervision

The Audio Notification Appliance Output Circuit uses Class B, Style Y wiring, and is supervised for open and short circuits when the output is de-energized. Output circuit supervision requires installation of UL Listed 10K Ohm, ½ W EOLR on the output circuit. A sensed open circuit trouble illuminates D1 AUDIO OPEN LED. A sensed strobe short circuit trouble illuminates D2 AUDIO SHORT LED. See Figure 8-1 for LED location.

5.3.3 Amplifier Supervision

An inaudible supervisory tone plays through the Amplifier section during standby for supervision purpose. Any sensed trouble illuminates D5 “AMP” LED steadily. See Figure 8-1 for LED location.

5.3.4 Ground Fault Supervision

The SP40S Multi-Function Facility Communication System supervises for Ground Fault conditions on Class B, Style Y field wiring that is not electrically isolated. The supervised wiring includes contact inputs, visual NAC circuits, audio NAC circuits, amplified speaker NAC circuits, and trouble audible output circuits. All other wiring is electrically isolated. If a Ground Fault condition exists, D67 GF LED illuminates. See Figure 8-1 for LED locations.

5.4 Actions that Initiate Audio Alarms

Table 5-1 indicates what can initiate an alarm condition and the resulting SP40S Multi-Function Facility Communication System actions.

Table 5-1. Audio Alarm Conditions and Results

PRIORITY OF EVENT	INITIATING ACTION	RESULT
1	Panel microphone push-to-talk button, is depressed.	Panel microphone live voice broadcast enabled.
2	Remote Microphone push-to-talk button is depressed	Remote MIC live voice broadcast is enabled.
3, 4, 5, 6, 7, 8, 9, 10	Digital Voice circuit Contact Closure inputs. (IN1, IN2, IN3, IN4, IN5, IN6, IN7, IN8)	Selected Digital Voice enabled. If digital voice is non-operational, program tone broadcasts.

6 Operational Procedures

6.1 Making Live Announcements

1. Hold the on board or remote microphone within 2 inches from your mouth, press the Push-To-Talk (PTT) switch and begin speaking. (For best results, hold the microphone within a half inch from your mouth.)
2. When finished, release the PTT switch and return the microphone to its holder.

NOTE: If the on-board microphone push-to-talk button is depressed and remains depressed for two and a half minutes, the microphone circuit switches automatically to the selected supervision tone.

6.2 Recording Digital Voice Messages

The Digital Voice section of the SP40S panel contains a digital voice memory chip that contains the digital voice program and the voice messages. The memory chip comes with eight messages installed. The DV Memory Chip can be removed and the messages remain on the chip. If tailored messages (messages with tones) are required from Cooper Wheelock Inc., the new chip can be installed when received.

- The message chip memory is divided into eight segments. Each segment is prioritized 1 through 8, matching the inputs IN1 through IN8.
- If the IN8 message is playing and a higher priority message is initiated, the message on IN8 stops immediately and the higher priority message plays.
- As long as the contact closure voltage is applied to the input, the message repeats. When the voltage is removed, the message plays to the end and stops. The message plays a minimum of three times completely.
- Each message can be selected to have a code3 pre-alert tone, a 1khz continuous pre-alert tone, or no pre-alert tone. This is based on SW4 and SW5, positions 1-8 settings.
- Post-tones are also selectable via SW5, position 9. Post-tones match pre-tones on an individual message basis.
- When the Digital Voice Section is set up for record mode, field recording is limited to 30-second segments.

NOTE: If the Digital Voice Section fails, the SP40S panel plays the selected tone (Code 3 Tone or Slow Whoop). See Figure 3-6 for the location of SW3-position 9. .

6.3 Recording Messages on the Digital Voice Section



CAUTION: Recording of any new message permanently erases the previous message. If a Cooper Wheelock, Inc. factory prerecorded fire or emergency message or a tailored message is accidentally or intentionally erased, a new factory recorded message kit must be purchased to restore the message.

- Decide which message segment to make the recording on.
 - Read through this procedure carefully before attempting a recording.
 - Identify all components mentioned.
1. Remove the DV Record Jumper JP5 (see Figure 3-5). Place jumper in a secure place; this is replaced at the end of the recording procedure.
 2. Connect 1/8" line level audio to audio jack (J2) on the left side of the SP40S unit.
 3. Press and hold the **RECORD** button on the user interface.
 4. Determine which one of the eight messages you wish to record.
 5. Press the message button on the interface corresponding to the message you wish to record. The Record LED illuminates and recording begins. You may release the record button at this point.
 6. When the message concludes, press the illuminated message button again. Recording then stops.
 7. Check the recorded message by pressing the proper DV message button. The message plays in its entirety at least three times.
 8. For additional message recording, repeat steps 2 through 7.
 9. When recording is done, replace DV Record Jumper (JP5).

6.4 Verifying Messages

NOTE: Verify that DIP switch JP5 is in place. See Figure 3-5 for location.

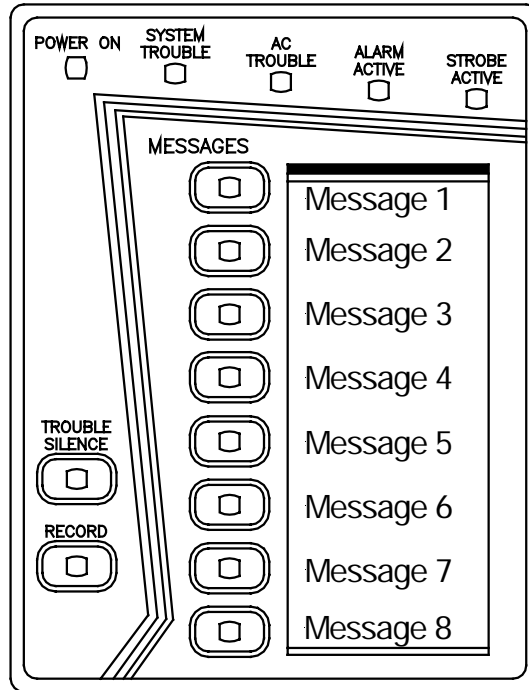

Figure 6-1 SP40S User Interface

1. Press the button of the desired DV message. The message will begin playback and the corresponding DV message LED will blink.
2. Press the blinking button again to deactivate the DV message. The message plays in its entirety a minimum of three times.

7 Periodic Testing and Maintenance

7.1 Introduction

- Conduct periodic testing and maintenance of the panel and all notification equipment frequently as required.
- Check local, state and federal codes, regulations and laws, for required tests.
- Make sure that only qualified personnel perform all tests and maintenance.

7.2 Periodic Testing

7.2.1 Test Frequency

- Perform mandatory testing of equipment at least twice each year, or more often as required by local, state and federal codes, regulations, and laws.

7.2.2 Equipment

The following equipment needs to be tested to ensure that equipment is operating properly:

- SP40S Multi-Function Facility Communication System
- All notification appliances

7.3 Faulty Equipment

- If the notification equipment is not working properly, contact the service representative and have problems corrected immediately.
- If the service representative is not available, contact the manufacturer.
- Replace any malfunctioning modules in the panel immediately. Do not attempt to repair them.
- Return any malfunctioning modules to the manufacturer for repair or replacement.

7.4 Qualified Personnel

“Qualified personnel” are those who can evaluate proper equipment functionality and ensure its proper operation and perform all testing procedures on the SP40S Multi-Function Facility Communication System.

 **WARNING: Provide alternative signaling means during periodic testing to assure adequate protection of people and property. Failure to provide alternative signaling may cause people to not be warned of an emergency condition which could result in serious injury or death to you and/or others.**

8 Troubleshooting

8.1 Introduction

 **WARNING:** Some electronic components store a high voltage charge, even though power is not connected, and can cause a dangerous shock if touched. Do not touch exposed circuitry on the SP40S Multi-Function Facility Communication System unless the circuitry has discharged for one hour and a safe discharge procedure is used.

 **WARNING:** Provide UL required alternative signaling means during trouble conditions and servicing to assure adequate protection of people and property. Ensure that qualified service persons immediately replace any modules that have malfunctioned.



CAUTION: Make sure that only qualified personnel in accordance with the procedures in this manual conduct troubleshooting and servicing. Do not attempt to make other adjustments, modifications, or repairs. Never use water, steam, cleaning liquids or sprays on the panel.



CAUTION: User servicing of the panel is limited to field-wiring changes, PC board replacement, and following the instructions in the Installation chapter (Chapter 4) and troubleshooting procedures in this chapter.

- After any troubleshooting procedure is completed, perform a complete system checkout as described in Section 4.6.

8.2 General

The SP40S Multi-Function Facility Communication System monitors system integrity. Items monitored for integrity are:

- Visual appliance circuit field wiring
- Audio appliance circuit field wiring
- Input voltage: AC (120VAC, 60 Hz), Backup Battery (24VDC)
- Battery voltage level
- Battery circuit field wiring
- Amplifier functionality
- Digital Voice Section functionality
- Battery charge voltage
- Tone generators
- Audio chain

System status is indicated to the visual indicators on the user interface, the internal Trouble Sounder, and the Trouble and AC Trouble Form "C" relay contacts. If the AC (primary power) is removed or low, the trouble the panel responds as follows:

- Turns "ON" the AC Trouble LED indicator on the user interface.
- Turns "ON" the System Trouble LED indicator on the user interface.
- Turns "ON" the internal sounder.
- Changes the state of the Form C AC Trouble contact to the TROUBLE position.
- Changes the state of the Form C General Trouble contact to the TROUBLE position. (After 170 minutes if SW2-Position 2=ON or after 30 seconds if SW2-Position 2=OFF)

Any other trouble detected by the panel is reported as follows:

- Turns "ON" the System Trouble LED indicator on the user interface.
- Turns "ON" the internal sounder.
- Changes the state of the Form C General Trouble contact to the TROUBLE position.

When there are no trouble conditions detected, the user interface has the POWER ON indicator illuminated while the SYSTEM TROUBLE and AC TROUBLE indicators are OFF. If the POWER ON indicator is not illuminated, check to see if D100 and/or D109 (on the PC board) are illuminated.

Figure 8-1 shows the location of all trouble location LED indicators within the SP40S. Table 8-1 cross-references the trouble location LED indicators on the PC board to the proper troubleshooting procedure.

***NOTE:** When the System Trouble indicator is ON, indicating a panel Trouble, at least one of the other yellow LED indicators is also ON, indicating the trouble location.*

Table 8-1. Trouble Procedure Cross Reference

Condition	Trouble Description	Troubleshooting Procedure
D109 (POWER ON LED) is OFF	AC and Battery power are missing or Low	Section 8.2.1 (A)
D96 AND D97 are ON	Strobe Overcurrent Protection is active	Section 8.2.2 (B)
D8 (BAT) is ON	Battery voltage is below 20.4 VDC or battery is missing	Section 8.2.3 (C)
AC TROUBLE (of display) is ON	AC input voltage missing or low	Section 8.2.4 (D)
D3 (DV) is ON	Digital Voice Signal is too low or missing	Section 8.2.5 (E)
D4 (MIC) is ON steady	Push-to-Talk Microphone inoperable or missing	Section 8.2.6 (F)
D5 (AMP) is ON steady	Audio Overcurrent Protection is active	Section 8.2.7 (G)
D96 (STB SHT) is ON	Strobe Notification Appliance Circuit is shorted	Section 8.2.8 (H)
D97 (STB OPEN) is ON	Strobe Notification Appliance Circuit is open	Section 8.2.9 (I)
D44 (AUX IN) is ON	Auxiliary input is open, RMX is in trouble, or remote MIC is in trouble	Section 8.2.10 (J)
D2 (AUD SHT) is ON	Audio Notification Appliance Circuit is Shorted, Splitter is in trouble, or Audio Booster is in trouble	Section 8.2.11(K)
D1 (AUD OPEN) is ON	Audio Notification Appliance Circuit is Open	Section 8.2.12 (L)
D67 (GF) is ON	Ground Fault Trouble	Section 8.2.13 (M)
D47 (INT TRB) is ON	User Interface is incorrectly connected or damaged	Section 8.2.14 (N)
D6 (EXT AC WIR) is ON	SPB SUP is open or Audio Booster has AC failure	Section 8.2.15 (O)
D5 (AMP) is blinking	Auxiliary preamp failure	Section 8.2.16 (P)
D4 (MIC) is blinking	Microphone preamp failure	Section 8.2.17 (Q)
D93 (CHG TRB) is ON	Battery voltage is below 18.5 VDC or battery is missing	Section 8.2.18 (R)
D55 (DV1) is ON	IN1 (DV input 1) is open	Section 8.2.19 (S)
D62 (DV2) is ON	IN2 (DV input 2) is open	Section 8.2.19 (S)
D58 (DV3) is ON	IN3 (DV input 3) is open	Section 8.2.19 (S)
D65 (DV4) is ON	IN4 (DV input 4) is open	Section 8.2.19 (S)
D75 (DV5) is ON	IN5 (DV input 5) is open	Section 8.2.19 (S)
D84 (DV6) is ON	IN6 (DV input 6) is open	Section 8.2.19 (S)
D78 (DV7) is ON	IN7 (DV input 7) is open	Section 8.2.19 (S)
D87 (DV8) is ON	IN8 (DV input 8) is open	Section 8.2.19 (S)
EXCESSIVE NOISE FROM SPEAKERS	MOTHERBOARD MAY NOT BE PROPERLY GROUNDED TO ENCLOSURE	Section 8.2.20(T)

Before performing any of the following troubleshooting procedures, make sure that you read, understand, and follow the preliminary troubleshooting information at the beginning of this “troubleshooting” chapter.

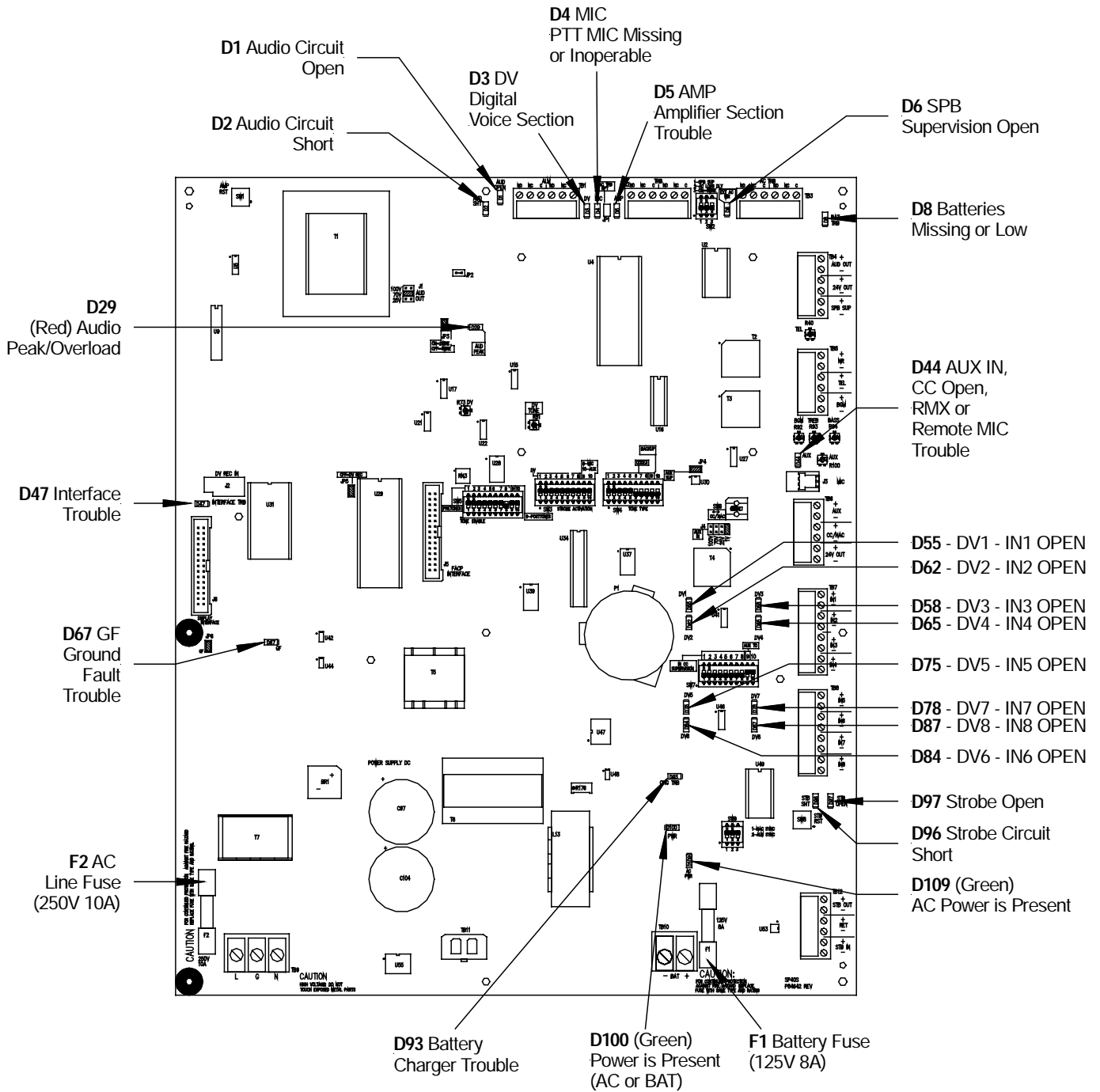

Figure 8-1 Trouble LED and Fuse Locations

8.2.1 Procedure A

If the green PWR LED is “OFF” and all other LEDs are “OFF,” a power loss condition has occurred. A power loss condition may be caused by:

- Loss of AC input voltage and battery back-up voltage.
- Faulty wiring of the AC power cord and batteries missing or low.
- Faulty motherboard.

Perform the following:

1. Check for 120 VDC at TB9 on the motherboard. If voltage is not present, check for AC input wiring. If AC voltage is present, check to see if fuse (F2) is blown. If F2 is blown, replace the fuse (250V, 10A)
2. Check for at least 18.5 VDC at TB10 (Battery terminals). If sufficient voltage is present, check to see if fuse (F1) is blown. If F1 is blown, replace the fuse (125V, 8A).
3. If the problem persists, replace the motherboard.

***NOTE:** Mark all wires before removing components. When the trouble is repaired, and before testing, replace all wires to the proper locations and replace all covers.*

8.2.2 Procedure B

If the green PWR LED is “ON,” the yellow SYSTEM TROUBLE LED is “ON,” and both D96 and D97 are ON, the SP40S panel is in an Overcurrent state.

- Check the strobe output for excessive current calculation. (2.0A for strobe circuit).

Perform the following:

1. If excessive current is calculated, remove appliances until the strobe current is below 2.0 Amps.
2. If excessive current does not exist, and strobe output is not operating, reset the SP40S by removing AC and battery power.
3. Wait 30 seconds and reapply power. AC first and then batteries.

8.2.3 Procedure C

If the green PWR LED is “ON,” the yellow SYSTEM TROUBLE LED is “ON,” and D8, BAT LED is “ON,” Battery Voltage is below 18.5 VDC or the battery is missing. A Battery Trouble condition might be caused by:

- Batteries are missing.
- Battery wiring is incorrect.
- Batteries are defective.
- Battery charging section of the motherboard is inoperable.

Perform the following:

1. Check the battery compartment for the presence of batteries. If batteries are not installed, install them.
2. Ensure that batteries are properly wired. See Figure 4-14 and 4-15 for reference.
3. With the batteries NOT connected to the SP40S measure the series voltage of the batteries. If the battery voltage is below 18.5VDC allow the SP40S more time to charge the batteries.
4. With the batteries NOT connected, check for 24VDC at (+, -) BAT connection at TB10 on the motherboard. If the voltage is below 18.5VDC, the battery charging section of the motherboard is inoperable. Replace the motherboard.
5. If Steps 1 through 4 are satisfied, replace the batteries.

NOTE: The Batteries could take up to 24 hours to charge to capacity.

8.2.4 Procedure D

If the green PWR LED is “ON,” the yellow SYSTEM TROUBLE LED is “ON,” the AC TROUBLE LED is “ON,” and the D93 CHG TRB LED is “ON” the AC is low or missing. An AC Trouble condition might be caused by:

- AC input missing or low.
- AC fuse (F2) is blown.
- A faulty motherboard.

Perform the following:

1. Check fuse F2 on the motherboard. Replace if necessary (250V, 10A).
2. Check for 120VAC at TB9
 - If voltage is not present, check the wiring and circuit breaker.
 - If voltage is present AND fuse F2 is not open, replace the motherboard.

8.2.5 Procedure E

If the green PWR LED is “ON,” the yellow SYSTEM TROUBLE LED is “ON,” D3 DV LED is “ON,” the Digital Voice messages are missing or the DV output voltage is too low. A DV Low Output Voltage condition might be caused by:

- Missing or incorrectly installed memory chip.
- Digital Voice volume control (R73) set too low.
- No messages recorded on memory chip.

Perform the following:

1. Check memory chip (U31) to ensure it is installed properly.
2. Verify that messages are recorded on the chip by activating them using the display buttons.
3. Check Digital Voice volume control (R73) for proper volume level.
4. If messages were field recorded, make sure the message(s) were recorded properly and at the proper volume.
5. Replace the motherboard.

8.2.6 Procedure F

If the green PWR LED is “ON,” the yellow SYSTEM TROUBLE LED is “ON,” D4 MIC LED is “ON” steadily, the push-to-talk microphone is missing, improperly plugged in, or defective.

Perform the following:

1. Install the microphone.
2. Remove the microphone plug and plug it back in.
3. Replace the microphone.
4. Replace the motherboard.

8.2.7 Procedure G

An Amplifier Trouble is present, if the green PWR LED is “ON,” the yellow SYSTEM TROUBLE LED is “ON,” and D5 AMP LED is “ON” steady. An Amplifier Trouble condition may be caused by:

- Short on the audio output.
- Overloaded audio output.
- Overcurrent circuit protection mode from improper power up.

Perform the following:

1. Check the TB4, Audio Out terminals and speaker wiring for shorts.
2. Check to ensure the speakers are tapped correctly.
3. Check to ensure the Output Select jumper (J1) is installed at the proper voltage level.
4. Reset the SP40S by removing AC and Battery power. Wait 30 seconds and reapply power. AC first and then batteries.
5. Replace the motherboard.

8.2.8 Procedure H

If the green PWR LED is “ON,” the yellow SYSTEM TROUBLE LED is “ON,” and D96, STB SHORT LED is “ON,” a short condition exists on the STB OUT NAC output circuit. A STB SHORT trouble condition might be caused by:

- Shorted appliance on STB OUT (TB12).
- Faulty wiring between STB OUT and strobe notification appliance circuit is causing a short.

Perform the following: Check the wiring and strobe notification appliances for a short circuit condition.

8.2.9 Procedure I

If the green PWR LED is “ON,” the yellow SYSTEM TROUBLE LED is “ON,” and D97 STB OPEN LED is “ON,” an open condition exists on the STB OUT NAC output circuit. A STB OPEN trouble condition might be caused by:

- Missing UL Listed 10K OHM, ½ W EOLR on the STB OUT circuit (TB12).
- Faulty wiring causing an open on the Strobe Notification Appliance Circuit.

Perform the following:

1. Check for proper EOLR.
2. Check the strobe notification appliance circuit wiring for an open condition.

8.2.10 Procedure J

If the green PWR LED is “ON,” the yellow SYSTEM TROUBLE LED is “ON,” and D44 AUX IN LED is “ON,” an open condition exists on the CC/NAC input circuit. An AUX IN trouble condition might be caused by:

- A Remote Microphone or RMX trouble being reported to the SP40S panel (if a remote MIC or RMX is connected).
- Faulty wiring is causing an open on the CC/NAC input circuit (TB6).
- Jumper JP2 being removed and missing a UL Listed 10K Ohm, ½ W EOLR on the CC/NAC circuit (TB6) (if a remote MIC is not connected).

Perform the following:

1. Check the Remote Microphone and/or RMX wiring for an open condition.
2. Check the jumper setting (JP4) if a Remote Microphone or RMX is not connected to the SP40S panel.
3. If the Remote Microphone or RMX is in a trouble condition, refer to that installation manual to troubleshoot that particular product.

8.2.11 Procedure K

If the green PWR LED is “ON,” the yellow SYSTEM TROUBLE LED is “ON,” and D2, AUDIO SHORT LED is “ON,” a short condition exists on the AUDIO OUT circuit. An AUDIO SHORT trouble condition might be caused by:

- Shorted speaker appliance on AUDIO OUT (TB4).
- Faulty wiring between AUDIO OUT and Speaker Notification Appliance Circuit is causing a short.
- A trouble being reported from an Audio Splitter or Audio Booster.

Perform the following:

- Check the wiring and Audio Notification Appliances for a short circuit condition.
- If a Splitter or Audio Booster is in a trouble condition, refer to that manual to troubleshoot that particular product.

8.2.12 Procedure L

If the green PWR LED is “ON,” the yellow SYSTEM TROUBLE LED is “ON,” and D1 AUDIO OPEN LED is “ON,” an open condition exists on the STB OUT NAC output circuit. A STB OPEN trouble condition might be caused by:

- Missing UL Listed 10K OHM, ½ W EOLR on the AUDIO OUT circuit (TB4).
- Faulty wiring is causing an open on the speaker notification appliance circuit.

Perform the following:

1. Check for proper EOLR.
2. Check the speaker notification appliance circuit wiring for an open condition.

8.2.13 Procedure M

If the green PWR LED is "ON," the yellow SYSTEM TROUBLE LED is "ON," and D67 GF LED is "ON," a ground fault condition exists on the output wiring. A GF trouble condition might be caused by:

- Appliance wiring touching conduit.
- Improper Installation of an appliance(s).

Perform the following:

1. Disconnect appliances from the strobe (TB12) and speaker (TB4) connection on the motherboard.
2. Troubleshoot the NAC circuits by checking for a resistance reading other than infinity between the appliance leads and the conduit.

8.2.14 Procedure N

If the green PWR LED is "ON," the yellow SYSTEM TROUBLE LED is "ON," and D47 INT TRB is "ON," an Interface Trouble exists. An Interface trouble might be caused by:

- The 30 pin ribbon cable being removed from the display or motherboard
- The 30 pin ribbon cable being connected to the wrong header.
- The 30 pin ribbon cable being damaged.

Perform the following:

1. Ensure that the ribbon cable is properly installed to the user interface and to the motherboard at J6 (Display Interface).
2. Check to see if the ribbon cable has been damaged in any way. If the ribbon cable is damaged, replace it.

8.2.15 Procedure O

If the green PWR LED is "ON," the yellow SYSTEM TROUBLE LED is "ON," and D6 EXT AC WIR is "ON," an open condition exists on the SPB SUP terminals (TB4). This trouble can be caused by:

- Switch SW2 position 1 is ON despite the SPB SUP terminals not being used.
- UL Listed 10k OHM ½ W EOLR not detected by the SUB SUP terminals.

Perform the following:

1. If AC is being reported separately from the Audio Booster, make sure that a 10k Ohm ½ W EOLR is properly installed at the Audio Booster and the Audio Booster is operating properly.
2. If AC is NOT being reported separately, make sure there is nothing on the SPB SUP terminals (TB4) AND Switch SW2 - position 1 (SPB SUP) is OFF.

8.2.16 Procedure P

If the green PWR LED is "ON," the yellow SYSTEM TROUBLE LED is "ON," and D5 AMP LED is blinking, an Auxiliary preamp trouble has occurred.

Perform the following:

1. Turn Aux Volume Pot (R100) fully clockwise.
2. Initiate the AUX input if it is being used (via Remote MIC).
3. Reset power to the SP40S board by turning it OFF and reenergizing it. Remove battery power first, then remove AC power. Wait 30 seconds. Apply AC Power first, then apply battery power.
4. Replace the motherboard.

8.2.17 Procedure Q

If the green PWR LED is "ON," the yellow SYSTEM TROUBLE LED is "ON," and D4 MIC LED is blinking, a Mic preamp trouble has occurred.

Perform the following:

1. Initiate the MIC input to verify its functionality.
2. Reset power to the SP40S board by turning it OFF and reenergizing it. Remove battery power first, then remove AC power. Wait 30 seconds. Apply AC Power first, then apply battery power.
3. Replace the motherboard.

8.2.18 Procedure R

If the green PWR LED is "ON," the yellow SYSTEM TROUBLE LED is "ON," and D93 BATT CHG TRB LED is "ON," a battery charger trouble has occurred.

***NOTE:** The CHG TRB LED turns ON during an AC TROUBLE. Restoring the AC Voltage turns OFF the CHG TRB LED.*

Perform the following:

1. Remove batteries and measure the voltage at the battery terminals (TB10). If voltage is present, above 20 Volts there is no problem with the battery charger.
2. If there is no voltage at the battery terminals (TB10) while the SP40S is running on AC power, then there is a problem with the battery charger. Replace the motherboard.

8.2.19 Procedure S

If the green PWR LED is "ON," the yellow SYSTEM TROUBLE LED is "ON," and one of the IN# LEDs (D55, D58, D62, D65, D75, D78, D84, or D87) are "ON," a DV Contact Closure Wiring Trouble exists.

Perform the following:

1. If a particular Contact Closure is not being used, make sure nothing is on the corresponding terminal block (TB7 or TB8) and the corresponding IN CC Supervision is turned OFF at switch SW7.
2. If a particular Contact Closure is being used, make sure that a UL approved 10k Ohm ½ W EOLR is installed on the proper terminals.

8.2.20 Procedure T

If the unit is in normal standby mode yet excessive noise is being heard from the speakers, the unit may not be properly grounded to the enclosure.

Perform the following:

1. Verify that the 4 metal standoffs are installed and securely fastened. Refer to figure 3-9 for location of the grounding standoffs.
2. Verify that the 4 screws are installed and securely fastened. Refer to figure 3-9 for location of the grounding screws.

9 Technical Data

9.1 Mechanical

Parameter	Description
Dimensions (H x W X D)	21 x 16 x 6 inches
Weight	36 lb
Finish	Red or Black
Enclosure	Enclosure Door: 16 Gauge (.060) CRS
Construction Type	Enclosure Backbox: 16 Gauge (.060) CRS
Mounting	Indoor surface mount
Wiring	Top, left, right, and bottom knockouts (3/4"-1") (18 total)
Entry	Top (2" - 2 ½" - 3") (2 total)
Door Lock	Standard Cooper Wheelock key-lock
PC Boards	1 Motherboard 1 Keypad board

9.2 Environmental

Parameter	Description
Operating Temperature	0 to 49 °C (32 to 120 °F)
Storage Temperature	-20 to 70 °C (-4 to 158 °F)
Humidity, Non-condensing	93% at 30 ± 2 °C (86 ± 4 °F)

9.3 Electrical

9.3.1 Input

Parameter	Description
Primary Input Voltage	120VAC, 2.4A, 60Hz
Secondary (Battery) Voltage	20.4-27.5VDC (33Ah)

9.3.2 Battery Current Calculations

The current draw of the SP40S Multi-Function Facility Communication System is determined by the configuration being used. Section 4.8, Battery Care and Battery Backup Calculation, will assist you in developing the current requirements.

9.3.3 Activation

There are nine ways to activate the SP40S panel. The table below lists these activation sources in order of priority.

Method of Activation	Description
Strobe	NAC 8-33VDC
Push-to-Talk Microphone	Connected to Mother Board
Auxiliary Input	Remote Microphone or RMX Initiation
IN1	Contact Closure. Activates Message 1 on Digital Voice Section.
IN2	Contact Closure. Activates Message 2 on Digital Voice Section.
IN3	Contact Closure. Activates Message 3 on Digital Voice Section.
IN4	Contact Closure. Activates Message 4 on Digital Voice Section.
IN5	Contact Closure. Activates Message 5 on Digital Voice Section.
IN6	Contact Closure. Activates Message 6 on Digital Voice Section.
IN7	Contact Closure. Activates Message 7 on Digital Voice Section.
IN8	Contact Closure. Activates Message 8 on Digital Voice Section.
Telephone Page	Telephone Page Port
Night Ring	Contact Closure
Background Music	Line Level Signal 2.5V P-P or 300mV RMS at 600 Ohms.

9.3.4 Outputs

Parameter	Description
Visual Notification Appliance Output	1 output circuit. 2.0 amps at 24VDC. Supervised.
Central Amplified Audio Output	1 output circuit. Selectable 25 or 70.7 Volt output at 40W max. Supervised.
Trouble Contact	Form C contact normally energized. Contacts transfer during trouble: 2.0 amps at 24VDC max, resistive load (see following warning). Non-Supervised.
Alarm Contact	Form C contact normally energized. Contacts transfer during alarm trouble: 2.0 amps at 24VDC max, resistive load (see following warning). Non-Supervised.
AC Trouble Contact	Form C contact normally energized. Contacts transfer during AC trouble: 2.0 amps at 24VDC max, resistive load (see following warning). Non-Supervised.

⚠ WARNING: Do not exceed the ratings of the status contacts. Exceeding this rating may cause the relay to fail and prevent a trouble condition from being indicated.

⚠ WARNING: Do not exceed the ratings of the alarm contacts. Exceeding this rating may cause the relay to fail and prevent the messages from being played.

9.4 Wiring Connections

Parameter	Description
Screw terminals	Accepts #12 to #18 AWG for single wire connection, or #16 to #18 AWG for double wire connection.

9.4.1 End of Line Resistor (EOLR)

Parameter	Description
Visual Notification Appliance Outputs	UL Listed 10K Ohm ½ W, EOLR
Audio Notification Appliance Outputs	UL Listed 10K Ohm ½ W, EOLR

10 Warranty

10.1 Limited Warranty

Cooper Wheelock products must be used within their published specifications and must be PROPERLY specified, applied, installed, operated, maintained, and operationally tested in accordance with these instructions at the time of installation and at least twice a year or more often and in accordance with local, state and federal codes, regulations and laws. Specification, application, installation, operation, maintenance, and testing must be performed by qualified personnel for proper operation in accordance with all of the latest National Fire Protection Association (NFPA), Underwriters' Laboratories (UL), Underwriters' Laboratories of Canada (ULC), National Electrical Code (NEC), Occupational Safety and Health Administration (OSHA), local, state, county, province, district, federal and other applicable building and fire standards, guidelines, regulations, laws and codes including, but not limited to, all appendices and amendments and the requirements of the local authority having jurisdiction (AHJ). Cooper Wheelock products when properly specified, applied, installed, operated, maintained, and operationally tested as provided above are warranted against mechanical and electrical defects for a period of three years from date of manufacture (as determined by date code). Correction of defects by repair or replacement shall be at Cooper Wheelock's sole discretion and shall constitute fulfillment of all obligations under this warranty.

The foregoing limited warranty shall immediately terminate in the event any part not furnished by Cooper Wheelock is installed in the product. The foregoing limited warranty specifically excludes any software required for the operation of or included in a product. **COOPER WHEELOCK MAKES NO REPRESENTATION OR WARRANTY OF ANY OTHER KIND, EXPRESS, IMPLIED OR STATUTORY WHETHER AS TO MERCHANTABILITY, FITNESS FOR A PARTICULAR PURPOSE OR ANY OTHER MATTER.**

Users are solely responsible for determining whether a product is suitable for the user's purposes, or whether it will achieve the user's intended results. There is no warranty against damage resulting from misapplication, improper specification, abuse, accident, or other operating conditions beyond Cooper Wheelock's control.

Some Cooper Wheelock products contain software. With respect to those products, Cooper Wheelock does not warranty that the operation of the software will be uninterrupted or error-free or that the software will meet any other standard of performance, or that the functions or performance of the software will meet the user's requirements. Cooper Wheelock shall not be liable for any delays, breakdowns, interruptions, loss, destruction, alteration, or other problems in the use of a product arising out of or caused by the software.

The liability of Cooper Wheelock arising out of the supplying of a product, or its use, whether on warranties, negligence, or otherwise, shall not in any case exceed the cost of correcting defects as stated in the limited warranty and upon expiration of the warranty period all such liability shall

terminate. Cooper Wheelock is not liable for labor costs incurred in removal, reinstallation, or for damage of any type whatsoever, including but not limited to, loss of profit or incidental or consequential damages. The foregoing shall constitute the sole remedy of the purchaser and the exclusive liability of Cooper Wheelock.

In no case will Cooper Wheelock's liability exceed the purchase price paid for a product.

10.2 Limitation of Liability

Cooper Wheelock's liability on any claim of any kind, including negligence and breach of warranty, for any loss or damage resulting from, arising out of, or connected with this contract, or from the manufacture, sale, delivery, resale, repair or use of any product covered by this order shall be limited to the price applicable to the product or part thereof which gives rise to the claim. Cooper Wheelock's liability on any claim of any kind shall cease immediately upon the installation in the product of any part not furnished by Cooper Wheelock. In no event shall Cooper Wheelock be liable for any claim of any kind unless it is proven that our product was a direct cause of such claim. **FURTHER, IN NO EVENT, INCLUDING IN THE CASE OF A CLAIM OF NEGLIGENCE, SHALL COOPER WHEELOCK BE LIABLE FOR INCIDENTAL, INDIRECT, SPECIAL OR CONSEQUENTIAL DAMAGES.** Some states do not allow the exclusion or limitation of incidental or consequential damages, so the preceding limitation may not apply to all purchasers.

11 Battery Backup Calculation Worksheet

SP40S BATTERY CALCULATION SHEET
STANDBY CURRENT CALCULATIONS

1. The Standby Current for the SP40S is 0.130 Amps. _____ Amps
2. Enter Auxiliary Current (If Applicable) _____ Amps
3. Add Steps 1 and 2. Multiply by the number of hours required.
 24 Hours – Multiply by 24 _____ Hrs

TOTAL STANDBY CAPACITY IN AMP HOURS _____ Ah

ALARM CURRENT CALCULATIONS

NOTE: DO NOT EXCEED 40 WATTS.

Good engineering practices call for amplifier to operate at 85% Max wattage.

1. List the speaker and strobe requirements.

NOTIFICATION APPLIANCE	SPEAKER WATTAGE	STROBE CURRENT

2. Calculate total Strobe current. (2. Amps Max.) _____ Amps
3. Calculate total speaker wattage. (40 Watts Max.) _____
4. Multiply the total speaker wattage on line 3 by 0.054. _____ Amps
5. Add Auxiliary Current (if applicable) _____ Amps
6. Add Steps 2,4 and 5 together. (4.66 Amps Max.) _____ Amps
7. Multiply Step 6 by 0.25 (This represents 15 minutes of alarm.) _____ Hrs
8. Total Alarm Capacity in Amps-Hours. _____ Ah

BACKUP BATTERY REQUIREMENTS

1. Enter Standby Capacity. _____ Ah
 2. Enter Alarm Capacity. _____ Ah
 3. Add Steps 1 and 2 together. _____ Ah
- Multiply Step 3 by 1.1 for minimum Backup Battery Requirements _____ Ah

NOTE: THE UL LISTED BACKUP BATTERIES FOR THIS PANEL ARE TWO 12 VOLT, 12 Ah.

-----Appendix E

Compatible Signaling Appliances

The following Wheelock products are LISTED compatible with the audio notification appliance output and the visual notification output circuits for the *SP40S* Panel. When connected to the SPB-80/4, strobe synchronization is system-wide. All strobe products can be fully synchronized.

Speakers

ET-1010-R	E50	STH-15SR
ET-1080	E60	STH-4R
ET70-R	E70	STH-3R
ET80	E90	STH-2R
ET90	S8-70/25	STH-2G

Strobes

RSS-24MCW	RSS-24MCC	RSSP-24MCW
RSS-24MCWH	RSS-24MCCH	RSSP-241575W
RSS-241575W	RSS-24MCCHR	DC-MAXS
RSSWP-2475W	RSSP-24MCWH	
ZRS-MCW		
ZRS-MCWH		

Speaker/Strobe Combination

ET-1080-IS-24	ET70-24MCW	S8-25/70MCC
ET-1080-LS-24	ET70-24MCWH	S8-25/70MCCH
ET-1080-LSM-24	ET70-241575W	STH-2MSR
ET-1080-MS-24	ET80-24MCW	STH-3MSR
ET-1080-SLM-24	ET80-24MCWH	STH-4MSR
E50-24MCW	ET80-241575W	STH-2R24MCCH
E50-24MCWH	ET90-24MCC	STH-3R24MCCH
E50-241575W	ET90-24MCCH	STH-4R24MCCH
E60-24MCC	E70-24MCW	STH-4M30WC
E60-24MCCH	E70-24MCCH	STH-90-R24MCCH
E60-24MCW	E70-241575W	

The following Wheelock products are LISTED compatible with the trouble audible output.

Bells:

MB-G6-24

MB-G10-24

