

MT-16H INSTALLATION MANUAL

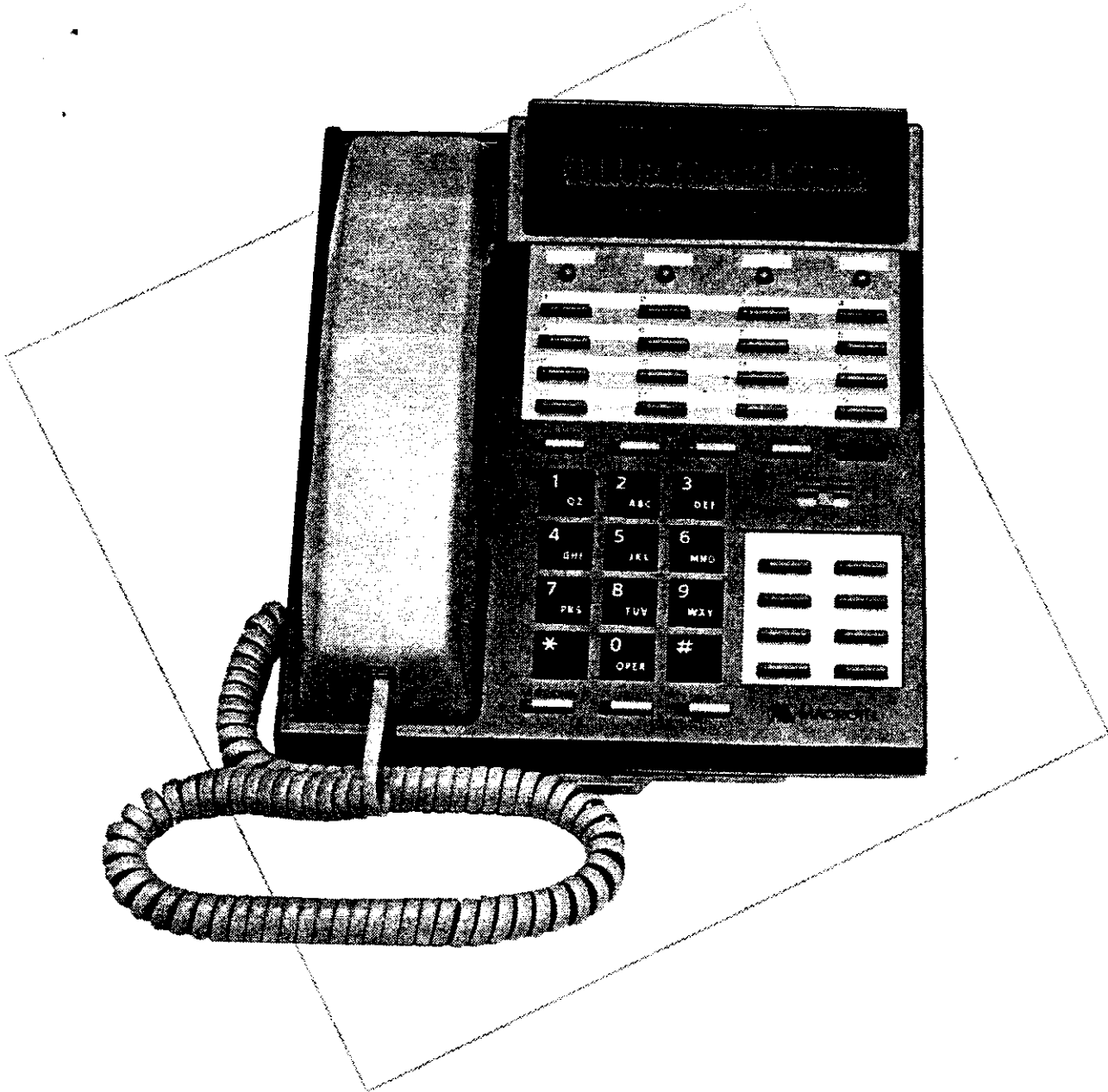

MACROTEL

P/N: 2609997
#176 Rev. 3.2
January, 1996



MACROTEL INTERNATIONAL CORPORATION
6001 Park of Commerce Boulevard
Boca Raton, FL 33487
Tel. (407) 997-5500
Fax. (407) 997-9922

MACROTEL INTERNATIONAL CORPORATION

MacroTel International Corporation reserves the right, without prior notice, to revise this information publication for any reason, including, but not limited to, utilization of new advances in the state of technical arts or to simply change the design of this document.

Further, MacroTel International Corporation also reserves the right, without prior notice, to make such changes in equipment design or components as engineering or manufacturing methods may warrant.

WARRANTY

MacroTel International Corporation warrants that this equipment (except for fuses, lamps and other consumables) will, upon delivery by an authorized MacroTel dealer to a retail customer in new condition, be free from defects in material and workmanship for twelve (12) months after purchase order from MacroTel. This warranty is void (a) if the equipment is used under other than normal use and maintenance conditions, (b) if the equipment is modified or altered, unless the modification or alteration is expressly authorized by MacroTel (c) if the equipment is subject to abuse, neglect, lightning, electrical fault or accident, (d) if the equipment is defaced or missing, or (f) if the equipment is installed or used in combination or in assembly with products not supplied by MacroTel and which are incompatible or of inferior quality, design or performance.

The sole obligation of MacroTel International Corporation under this warranty, or under any other legal obligation with respect to the equipment, is the repair or replacement by an authorized MacroTel dealer, with new or refurbished parts (at their option) of such defective or missing parts causing the malfunction. If MacroTel or one of its authorized dealers does not replace or repair such parts, the retail customer's sole remedy will be a refund of the price charged by MacroTel to its dealers for such parts as are proven to be defective, and which are returned to MacroTel through one of its authorized dealers within the warranty period and no later than thirty (30) days after such malfunction, whichever first occurs.

Under no circumstances will the retail customer or any user or dealer or other person be entitled to any direct, special, indirect, consequential or exemplary damages, for breach of contract, tort, or otherwise. Under no circumstances will any such person be entitled to any sum greater than the purchase price paid to MacroTel for the item of equipment that is malfunctioning.

To obtain service under this warranty, the retail customer must bring the malfunction of the machine to the attention of MacroTel's authorized dealer within the twelve (12) month period and no later than thirty (30) days after such malfunction, whichever first occurs. Failure to bring the malfunction to the attention of an authorized MacroTel dealer within the prescribed time, results in the customer being not entitled to warranty service.

THERE ARE NO OTHER WARRANTIES FROM MACROTEL INTERNATIONAL CORPORATION WHICH EXTEND BEYOND THE FACE OF THIS WARRANTY. ALL OTHER WARRANTIES, EXPRESS OR IMPLIED, INCLUDING THE WARRANTIES OF MERCHANTABILITY, FITNESS FOR A PARTICULAR PURPOSE, AND FITNESS FOR USE, ARE EXCLUDED.

No MacroTel dealer and no person other than an officer of MacroTel may extend or modify this warranty. No such modification or extension is effective unless it is in writing.



Copyright © 1993, MacroTel International Corporation. All Rights Reserved Worldwide. This publication has been provided pursuant to an agreement containing restrictions on its use. This publication is also protected by federal copyright laws. No part of this publication may be copied or distributed, transmitted, stored in a retrieval system or translated into any human or computer language, in any form or by any means, electronic, mechanical, magnetic, manual or otherwise, or disclosed to third parties without the express written permission of MacroTel International Corporation, 6001 Park of Commerce Blvd., Boca Raton, Florida 33487.

MacroTel International Corporation reserves the right to revise this manual and to make changes from time to time in the content hereof without obligation to notify any person or organization of such revision or changes. Due to ever-changing nature of the high tech environment as well as the complexity of this product, MacroTel International Corporation assumes no responsibility for any errors or omissions that may appear in this publication.

CUSTOMER INFORMATION SHEET

CUSTOMER NAME: _____

MAIN TELEPHONE NUMBER OF CUSTOMER: () _____

MANUFACTURER: MacroTel International Corporation

MODEL: MT-16H

FCC: #E4KUSA-61239-KF-E
#E4KUSA-61228-MF-E

REN: 1.3B

FACILITY INTERFACE CODES: E&M Tie Line - TL11E

SERVICE ORDER CODE: 9.0F

REQUIRED NETWORK INTERFACE JACK: C.O. Lines - RJ14C
E&M Tie Lines - RJ2EX

MODEL #: _____

SERIAL #: _____



TABLE OF CONTENTS

1.0	PURPOSE OF MANUAL	
	General Description	1
	Installation	1
	Programming	1
	Troubleshooting	1
2.0	FCC REQUIREMENTS	1
3.0	GENERAL DESCRIPTION	
	Overview	2
	KSU	2
	CPU Processor Unit(Figure 1)	2
	Network Control (Figure 2)	3
	Power Supply	3
	System Components	3
	Power Supplies	4
	Doorphone	4
	Expansion Cards	4
	SMDR Card	4
	LCD Display Kit	4
	Wall Mount Kit	4
	Battery Backup	4
	Single Line Telephones	4
	Electronic Telephone Sets	5
	MT-16T Telephone Set (Figure 3)	5
	Maximum System Capacities	6
	Electrical Specifications	6
	KSU Physical Characteristics	7
	Environmental Specifications	7
	Ventilation	7
	Electronic Key Phone Audible & Visual Indications	7
	System Tones	8
	Single Line Telephone Audible Indications	8
	System Connection Layout (Figure 5)	9
4.0	FEATURE DESCRIPTIONS	10
5.0	INSTALLATION	
	Overview	15
	Precautions	15
	Equipment Verification	16
	Installation Location Checklist	16
	Tools Checklist	17
	Facilities Location (Figure 6)	17
	Main Distribution Frame (MDF)	18
	Station Cables	18
	Terminating Station Cables at the MDF	18
	Terminating Station Cables at Keypad/SLT Locations	18
	Central Office Lines	18
	Before Mounting KSU	18
	Mounting the KSU (Figure 7)	19
	Frame Ground Connections (Figure 8)	19
	Installing the Keypads/SLT	20
	Dip Switch Settings for Stations 7&8 (Figure 9)	20
	Station Cabling for Single Line Telephone	21
	Connection of Keypad and SLT (Figure 10)	21
	Connecting Central Office Lines	22
	Connection of C.O./E & M Tie Lines (Figure 11)	22
	Expansion Cards	23
	Switch Settings for MT-STU/C (Figure 12)	23
	Installing Expansion Cards	23
	Installation of Expansion Cards (Figure 13)	24
	Connecting External Paging Speakers	24
	Connecting Doorphone and Door Lock Control	24
	External Page and Doorphone Connections (Figure 14)	25
	Internal Music Source	25
	Changing Internal Music Source (Figure 15)	25
	Connecting External Music Source	26
	Music on Hold/BGM Connections (Figure 16)	26
	Connecting Printer or Terminal (SMDR)	27
	Wiring and Dip Switch Settings for SMDR (Figure 17)	27
	SMDR Format	27
	Power Failure Transfer (TTC Connector, Figure 18)	28
	Battery Backup (Figure 20)	28
	LCD Display Kit Installation	29
	LCD Installation Diagrams (Figure 21)	29
	Memory Battery Initialization (Figure 22)	30
6.0	CUSTOMER DATABASE PROGRAMMING SHEETS	33
7.0	SYSTEM PROGRAMMING (See Index provided)	40
8.0	TROUBLE SHOOTING	61
	Dip Switches	61

IMPORTANT SAFETY INSTRUCTIONS

1. Read and understand all instructions.
2. Follow all warnings and instructions marked on the product.
3. Unplug this product from the wall outlet before cleaning. Do not use liquid cleaners or aerosol cleaner. Use a damp cloth for cleaning.
4. Do not use this product near water, for example, near a bath tub, wash bowl, kitchen sink, or laundry tub, in a wet basement,
5. Do not place this product on an unstable cart, stand, or table. The product may fall causing serious damage to the product.
6. Slots and openings in the cabinet and the back or bottom are provided for ventilation, to protect it from overheating, these openings must not be blocked or covered. The openings should never be blocked by placing the product on the bed, sofa, rug or similar surface. This product should never be placed near or over a radiator or heat register. This product should not be placed in a built-in installation unless proper ventilation is provided.
7. This product should be operated only from the type of power source indicated on the marking label. If you are not sure of the type of power supply to your home, consult your dealer or local power company.
8. (If provided with a grounded type attachment plug) This product is equipped with a three-wire grounding type plug, a plug having a third (grounding) pin. This plug will only fit into a grounding type power outlet. This is a safety feature. If you are unable to insert the plug into the outlet, contact your electrician to replace your obsolete outlet. Do not defeat the safety purposes of the grounding type plug. (If provided with a polarized attachment plug) This product is equipped with a polarized line plug (a plug having one blade wider than the other). This plug will fit into the power outlet only one way. This is a safety feature. If you are unable to insert the plug fully into the outlet try reversing the plug. If the plug should still not fit, contact your electrician to replace your obsolete outlet. Do not defeat the safety purposes of the polarized plug.
9. Do not allow anything to rest on the power cord. Do not locate this product where the cord will be abused by persons walking on it.
10. Do not overload wall outlets and extension cords as this can result in the risk of fire or electric shock.
11. Never push objects of any kind into this product through cabinet slots as they may touch dangerous voltage points or short out parts that could result in a risk of fire or electric shock. Never spill liquid of any kind on the product.
12. To reduce the risk of electric shock, do not disassemble this product, but take it to a qualified serviceman when some service or repair work is required. Opening or removing covers may expose you to dangerous voltages or other risks. In correct reassembly can cause electric shock when the appliance is subsequently used.
13. Unplug this product from the wall outlet and refer servicing to qualified service personnel under the following conditions.
 - A. When the power supply cord or plug is damaged or frayed.
 - B. If liquid has been spilled into the product.
 - C. If the product has been exposed to rain or water.
 - D. If the product does not operate normally by following the operating instructions. Adjust only those controls, that are covered by the operating instructions because improper adjustment of other controls may result in damage and will often require extensive work by a qualified technician to restore the product to normal operation.
 - E. If the product has been dropped or the cabinet has been damaged.
 - F. If the product exhibits a distinct change in performance.
14. Avoid using a telephone (other than a cordless type) during an electrical storm. There may be a remote risk of electric shock from lightning.
15. Do not use the telephone to report a gas leak in the vicinity of the leak.
16. Never install telephone wiring during a lightning storm.
17. Never install telephone jacks in wet locations unless the jack is specifically designed for wet locations.
18. Never touch uninsulated telephone wires or terminals unless the telephone line has been disconnected at the network interface.
19. Use caution when installing or modifying telephone lines. The exclamation point within an equilateral triangle is intended to alert the user to the presence of important operating and maintenance (servicing) instructions in the literature accompanying the product. The installation instructions provided with equipment intended to be locally powered over telecommunications wiring systems shall include all of the following.
 - A. The current limitations and maximum overcurrent protection for Level C circuits.
 - B. Reference to the specific power supply or current limiting device provided with the product and,
 - C. Detailed instructions showing the proper method of installation and connections to the telecommunications wiring system.

To reduce the risk of fire or injury to persons, read and follow these instructions

1. Use only the MacroTel provided battery back-up kit.
2. Do not dispose of the battery(ies) in a fire. The cell may explode. Check with local codes for possible special disposal instructions.
3. Do not open or mutilate the battery(ies). Released electrolyte is corrosive and may cause damage to the eyes or skin. It may be toxic if swallowed.
4. Exercise care in handling batteries in order not to short the battery with conducting materials such as rings, bracelets, and keys. The battery or conductor may overheat and cause burns.
5. Charge the battery(ies) provided with or identified for use with this product only in accordance with instructions and limitations specified in this manual.
6. Observe proper polarity orientation between the battery(ies) and battery chargers.
7. Do not mix old and new batteries in this product (applies to products employing more than one user replaceable secondary battery).
8. Do not mix batteries of different sizes or from different manufacturers in this product (applies to products employing more than one user replaceable secondary battery).

1.0 PURPOSE OF MANUAL

This manual details the instructions and procedures required to install, program and maintain the MT-16H Electronic Key Telephone System. For convenience, the manual has been written in separate sections. They are as follows:

GENERAL DESCRIPTION: Provides an overview of system operation, capacities and physical characteristics.

INSTALLATION: Detailed installation instructions to enable the installer to complete the installation of the KSU and associated equipment.

PROGRAMMING: Step by step procedures are provided that allow the installer to program the customer database. Programming sheets can be left on site.

TROUBLESHOOTING: The last section covers troubleshooting procedures to be followed should the installer encounter any difficulties.

2.0 TELEPHONE COMPANY AND F.C.C. REQUIREMENTS AND RESPONSIBILITIES

In compliance with the requirements of Part 68 of the F.C.C. Rules and Regulations for connection of terminal system (this device is classified as a terminal system) to the telephone network and for your convenience, the following information is presented:

1. Notification to the Telephone Company

Customers connecting terminal equipment to the telephone network shall, upon request of the Telephone Company, inform the Telephone Company of the particular line(s) to which such connection is made, the F.C.C. registration number (see label on side of unit) and ringer equivalence number (REN) of the registered terminal equipment.

The REN is useful to determine the quantity of devices you may connect to your telephone line and still have all of those devices ring when your telephone number is called. In most, but not all areas, the sum of the REN's of all devices connected to one line should not exceed five (5.0). To be certain of the number of devices you may connect to your line, as determined by the REN, you should contact your local telephone company to determine the maximum REN for your calling area.

2. Direct Connection to a Party-Line or Coin-Operated Telephone Line is Prohibited.

3. Incidence of Harm to the Telephone Lines

Should terminal equipment cause harm to the Telephone Network, the Telephone Company shall, where practical, notify the customer that service may be temporarily discontinued. However, where prior notice is not practical, the Telephone Company may temporarily discontinue service forthwith, if such action is reasonable in the circumstances. In case of such un-notified temporary discontinuance of service, the Telephone Company shall:

- (a) Promptly notify the customer of such temporary discontinuance of service.
- (b) Afford the customer the opportunity to correct the situation which gave rise to the temporary discontinuance.
- (c) Inform the customer of the right to bring a complaint to the Commission pursuant to the procedures set out in Subpart E of Part 68 of FCC Telephone Equipment Rules.

4. Compatibility of the Telephone Network and Terminal Equipment

- (a) Availability of telephone interface information.
Technical information concerning interface parameters and specifications not specified in FCC Rules, including the number of Ringers which may be connected to a particular line, which is needed to permit Terminal Equipment to operate in a manner compatible with Telephone Company communications facilities, shall be provided by the Telephone Company upon customer's request.

- (b) Changes in Telephone Company Communications Facilities, Equipment, Operations and Procedures.

The Telephone Company may make changes in its communications facilities, equipment, operations or procedures, where such action is reasonably required in the operation of its business and is not inconsistent with the rules and regulations in FCC Part 68 of the FCC Rules and Regulations. If such changes can be reasonably expected to render any customer Terminal Equipment incompatible with Telephone Company Communications Facilities, or require modification or alteration of such Terminal Equipment, or otherwise materially affect its use or performance, the customer shall be given adequate notice in writing to allow the customer an opportunity to maintain uninterrupted service.

5. Dual Registration Notification

When the MT-16H is installed and programmed to have manual and automatic selection of outgoing lines, it is considered to be a hybrid system. Therefore, it must be registered as such. Because of this duality, the F.C.C. has granted the MT-16H system a dual registration. The installer is required to notify the telephone operating company of the correct registration number that reflects the configuration of the installation. The installer may be required to certify in writing to the telephone company how the system is configured.

RADIO FREQUENCY INTERFERENCE

This equipment generates and uses radio frequency energy and if not installed and used properly, that is in strict accordance with the manufacturer's instructions, may cause interference to radio and television reception. It has been type-tested and found to comply with the limits for a Class A computing device in accordance with the specifications in Subpart J of Part 15 of FCC Rules, which are designed to provide reasonable protection against such interference in a residential installation. However, there is no guarantee that interference will not occur in a particular installation. If this equipment does cause interference to radio or television reception, which can be determined by turning the equipment off and on, the user is encouraged to try to correct the interference by one or more of the following measures:

-Reorient the receiving antenna
-Relocate the equipment with respect to the receiver
-Move the equipment away from the receiver
-Plug the equipment into a different outlet so that equipment and receiver area are on different branch circuits

3.0 GENERAL DESCRIPTION

OVERVIEW

The general description section provides detailed information of the operation of the MT-16H Electronic Key Telephone System. The CPU, network interface and system components are described in order to provide a working knowledge of the equipment and its operation.

GENERAL DESCRIPTION OF KSU

The system architecture of the MT-16H is designed with "state of the art" components and high quality design criteria. The system is organized into three major sections: The Central Processing Unit, the Speech Path Network and Interface, and the Power Supply section.

CPU PROCESSOR UNIT

The heart of the system is controlled by a Z80-A Microprocessor. When the AC power is turned on, the power-on reset initializes the CPU. The CPU, in turn, requests instructions from the ROM to start call detection and processing. Temporary data is stored in the RAM along side user programmed data.

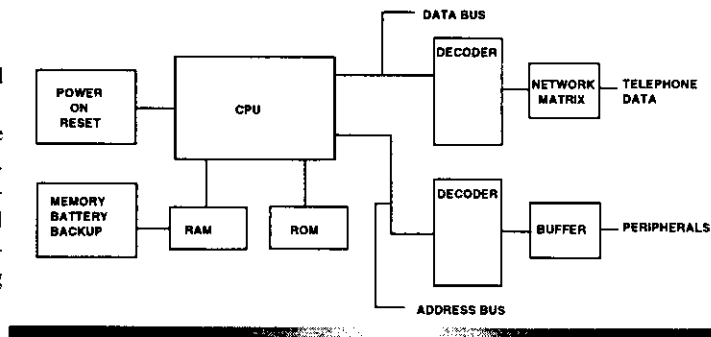

FIGURE 1

The user programmed data is backed up by a 3.7 volt NICAD battery that is under constant trickle charged by the KSU power supply. The NICAD is also used to provide backup voltage for the real time clock. The NICAD battery will protect the speed dial numbers and customer database until the power outage exceeds approximately 40 hours. When the AC power is turned ON, the NICAD recharges.

Memory power backup circuitry is monitored by voltage detecting circuitry controlled by the CPU and, in turn, works with the power supply circuitry, which monitors the DC output of the power supply.

NETWORK CONTROL

The network is designed using solid state, space division architecture to insure low loss and channel flexibility.

Audio Channels

Common Path	10
Doorphone	1
DTMF	1
MOH	1
Internal Tones	1
External Page	1

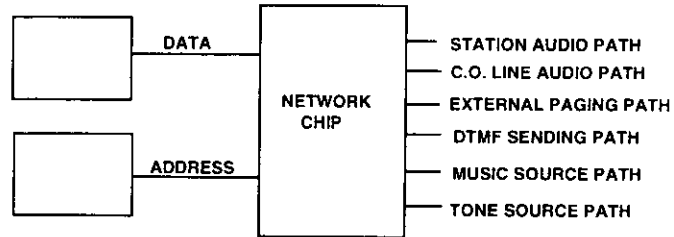

FIGURE 2

The 12 x 8 cross point supports common audio channels, DTMF sending channel, music source channel, and the external paging source channel. In the event that all common channels are busy and an incoming call is ringing, the system will select the external page channel and ring the appropriate phone(s). If that channel is busy, the system will notify the system operator via the alarm tone. When the power-on sequence takes place, the matrix is instructed to connect all stations with a tone. This checks the data connection showing the digital communication is working between the KSU microprocessor and the telephone microprocessor. It also checks that the audio path from the KSU network is communicating with the telephone network.

POWER SUPPLY

The power supply section consists of components which change 110/220 AC voltage into DC voltage which the integrated circuits use. Working in conjunction with this circuitry, the MT-16H employs an on-line monitoring circuit which detects under voltage and over voltage.

In the event the system loses the AC voltage and the system battery backup has been installed, the system detects when the batteries have discharged to such a rate that the KSU is no longer usable. Instead of allowing the batteries to completely discharge which may damage the batteries, the system disconnects the batteries.

When the AC voltage is restored to the KSU, the circuitry also monitors the charging of the batteries. Charging will take place until the monitor circuit detects the batteries are in a charged state; which, in turn, turns off the charging circuit thereby preventing the batteries from being overcharged.

SYSTEM COMPONENTS

The basic MT-16H cabinet is a 408 configuration expandable to a 612 and 816 configuration. The 408 cabinet provides for 4 central office lines, 1 doorphone and 8 electronic telephones. Two (2) of the 8 telephones are optionally selectable as keyphones or single line telephones. Included in the cabinet is a ring generator for single line telephones, power supply PCB and the main PCB. The following are also contained on the main PCB:

- Z80-A Microprocessor
- Associated Logic and Memory Circuitry
- Real Time Clock
- RAM Battery Backup
- System Timer
- Speech Path Network Circuit
- External Paging Circuitry
- Music on Hold Circuitry

POWER SUPPLIES

- AC to DC rectification
- External system battery backup monitoring and control
- DC battery input fuse
- Battery backup
- Ring generator for single line telephones

DOORPHONE

The MT-16H main PCB contains circuitry for 1 Doorphone. Calling to and from the KSU is standard and also a door lock relay contact is provided. The user, after answering the call, may depress the door key (or dial 3) which, in turn, activates the relay. Programming in the database activates the hardware.

EXPANSION CARDS

The MT-16H KSU supports the following three expansion cards:

MT-STU/A

Provides additional capacity of 2 C.O. lines and 4 keysets. Programming activates the additional C.O. lines and keysets.

MT-STU/B

Provides additional capacity of 2 C.O. lines and 4 single line telephone circuits. Programming activates the additional C.O. lines and single line telephones.

MT-STU/C

Provides additional capacity of 2 C.O. lines or 2 E&M tie lines and 4 keysets. Programming activates the additional C.O. or E&M lines and keysets.

SMDR CARD

This card is used to record details for calls made to the public switched network. A printer or monitor is required.

LCD DISPLAY KIT

The LCD Display Kit is field installed and allows the user to upgrade to a display telephone without having to replace the original telephone. No programming is needed to enable this feature.

WALL MOUNT KIT

The WMK is a dual function kit which allows the phone to be attached to a wall in a vertical manner or by reversing the unit, provides a 28 degree elevation to the telephone.

BATTERY BACKUP

MacroTel provides an optional backup kit (PN #2208037) for the MT-16H. This is to be used when commercial power has failed. When fully charged, the batteries will provide power for 6 to 8 hours, depending on usage.

SINGLE LINE TELEPHONES

Any industrial standard single line telephone may be installed on the MT-16H. The total ringer equivalency should not exceed 5.0B per single line port or damage to the system might result.

ELECTRONIC TELEPHONE SETS

The MT-16T telephones support 8 C.O. lines and 16 stations. It has a built-in speakerphone and an optional LCD unit may be installed at a later date. Any phone location may be used to program the system database as long as the correct security code is entered. All phones support dual color LEDs to distinguish active lines and utilize separate volume controls for C.O. line ringing and hands-free conversation. All phones are equipped with magnetic receiver transducers compatible with most hearing aid pickup coils.

MT-16T TELEPHONE SET

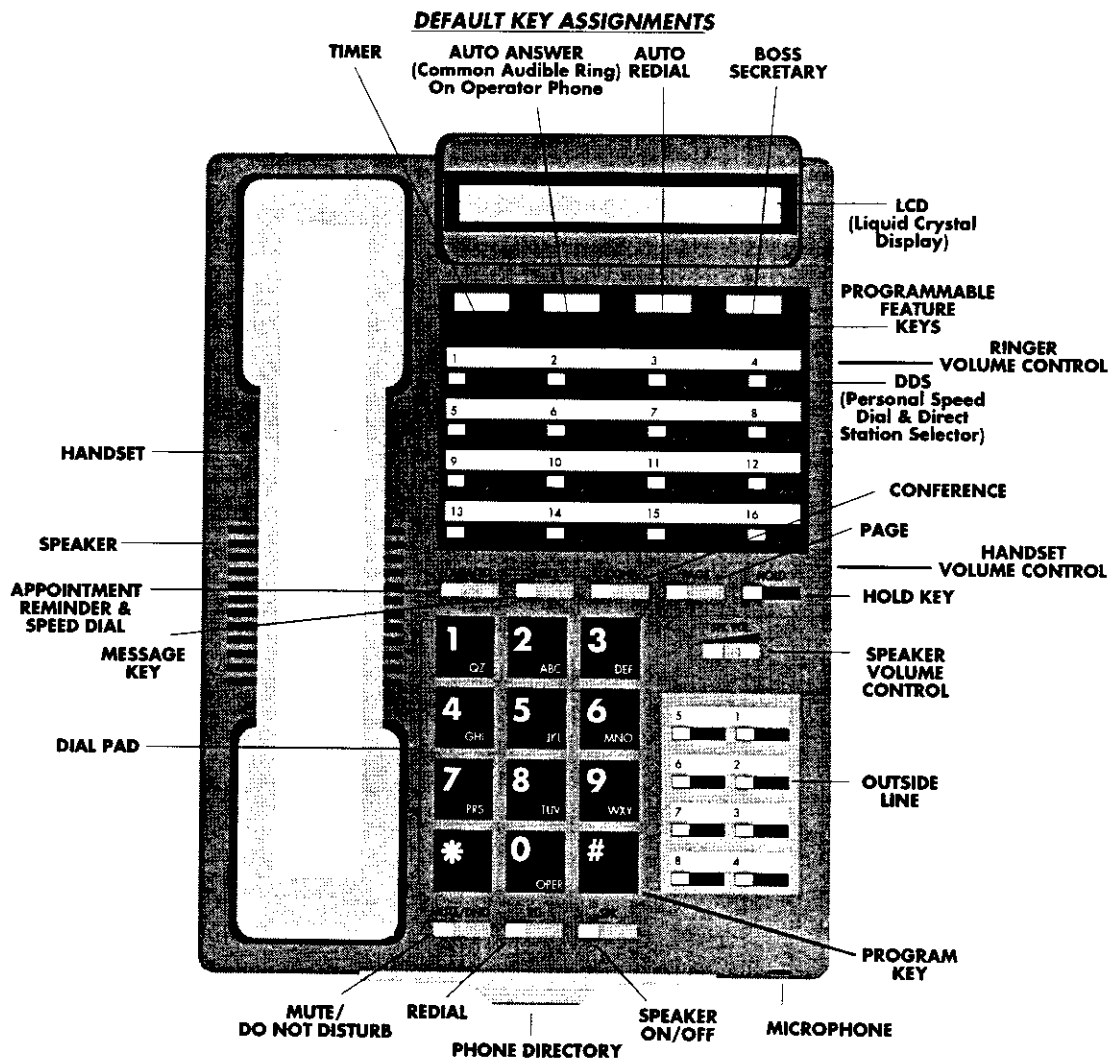

FIGURE 3

MAXIMUM SYSTEM CAPACITIES

	MT-16H
• Key Stations	16
• Single Line Telephones (Rotary or DTMF)	10
• Central Office Lines	8
• Tie Lines (2 wire E&M Type 1)	4
• Speed Dial Numbers (up to 30 digits)	
System	90
Station	16
• Doorphone	1
• Conference	
Simultaneous parties	5
Simultaneous conferences	6
• Simultaneous Call Forwards	16
• Station Status Messages	20
• Toll Restriction (5 classes)	
Class 0 is unrestricted	
Class 1 follows a programmable allow/deny table	
Class 2 follows another programmable allow/deny table	
Class 3 follows an allow table	
Class 4 restricts station to internal calls only	
Digits monitored: Up to 10	
• Page Zones	
External	1
Internal	4
• Boss/Secretary Station Assignment	1
• Ringing Stations	
Day	8
Night	8
• Automatic Power Failure Transfer Circuits	6
• DTMF Receiver	6
• DTMF Sender	1

ELECTRICAL SPECIFICATIONS

INPUT

AC Input	115/220 VAC at 60/50Hz
Power Consumption	60.5 watts maximum
Current Draw	1.0 AMP maximum

ALLOWABLE VARIANCES

115 VAC	110~130 VAC
220 VAC	210~230 VAC
60Hz	50~65Hz

OUTPUTS

Main Power Supply	5V ± 5% @ 1.0A DC
	12V ± 10% @ 1.0A DC
	-12V ± 10% @ 0.2A DC
	30V max @ 1.0A DC
	24V min @ 1.0A DC
Ring Generator	80V ± 10% @ 0.06A AC (20 Hz)

MUSIC ON HOLD SPECIFICATIONS

Input Level	600 OHMS
Input Voltage Maximum	250 mV (Nominal) @ -10dbm
Output Maximum	1 Volt RMS
Use Johnson Plug	Miniature 1/8" (3.5mm)

EXTERNAL PAGING SPECIFICATIONS

Output Level
Output Maximum

250 mV (Nominal) @ -10dbm
400 mVRMS

HANDSET

Dynamic Transducers

KSU PHYSICAL CHARACTERISTICS

<u>Weight</u>	<u>Dimensions</u>
22.5 lbs (10.2Kg)	20.75" (527mm)H x 13.56" (344.4mm)W x 3.44" (87.4mm)D

ENVIRONMENTAL SPECIFICATIONS

To provide optimal performance of the equipment, the following guidelines should be followed:

- **KSU - operating range**
41°F (5°C) - 104°F (40°C)
- **Relative humidity**
Not more than 90% non condensing

VENTILATION

This equipment uses state-of-the-art components which generate very little heat. Although it does not require strict environmental conditions, it is strongly suggested that the equipment (mainly the KSU) be in a controlled environmental area. Places such as garages, cleaning rooms, etc., have high heat, dust and/or corrosive air which reduces the life of any equipment.

ELECTRONIC KEY PHONE AUDIBLE AND VISUAL INDICATIONS		
LED	STATUS	LINE STATUS
INTERCOM LED	OFF 360 IPM 0.5 sec ON/0.5 sec OFF ON	- Idle - Placing an ICM Call - Station is on HOLD - Busy
C.O. LINE LED	OFF 360 IPM (GREEN) 0.5 sec ON/0.5 sec OFF (GREEN) ON (RED)	- Idle - Receiving an outside line call - Outside Line is on Hold - Other station is using the outside line
PRIVACY RELEASE	3 Flashes @ 360 IPM/0.5 ON	- Outside line is available for other user to join in conversation.

TONE	STATUS	LINE STATUS
DIAL TONE	Steady	When the handset is lifted or SPK button is pressed - HOLD button is pressed while talking to station or C.O. line
BUSY TONE	0.5 sec ON/0.5 sec OFF	-Selected outside line or ICM is busy
RING BACK TONE	1 sec ON/2 sec OFF	-When calling another station on intercom
TRANSFER TONE CONFERENCE TONE	0.25 sec ON/.25 sec OFF	-Conference button is pressed
CONFIRMATION TONE		-When a feature is confirmed
NOT USED TONE	0.5 sec ON/2.5 sec OFF	-When DSS key to which no keyset is connected is pressed -When outside line key to which no outside line is connected is pressed

RING TONE	STATUS	
INCOMING LINE RING	1 sec ON/2 sec OFF	-When an outside line is ringing
STATION LINE RING	0.4 sec ON/0.2 sec OFF/ 0.4 sec ON/2 sec OFF	-When a station is receiving an ICM call
DOORPHONE RING (ALARM RING)	0.5 sec ON/0.5 sec OFF	-When a doorphone is ringing a station

SINGLE LINE TELEPHONE AUDIBLE INDICATIONS

TONE	STATUS	
DIAL TONE	Steady	When the handset is lifted or when call is put on hold.
BUSY TONE	0.5 sec ON/0.5 sec OFF	When selected outside line or ICM is busy.
RING BACK	1 sec ON/2 sec OFF	When calling another station on ICM.
TRANSFER TONE	0.25 sec ON/0.25 sec OFF	When station hook flashes to transfer a call.
NOT USED TONE	0.5 sec ON/2.5 sec OFF	When station or outside line selected is not connected to the system.
INCOMING LINE RING	1 sec ON/3 sec OFF	When an outside line is ringing.
STATION LINE RING	1 sec ON/1 sec OFF	When a station is receiving an ICM call.
DOORPHONE RING	0.5 sec ON/0.5 sec OFF	When a doorphone is ringing a station.

SYSTEM CONNECTION LAYOUT

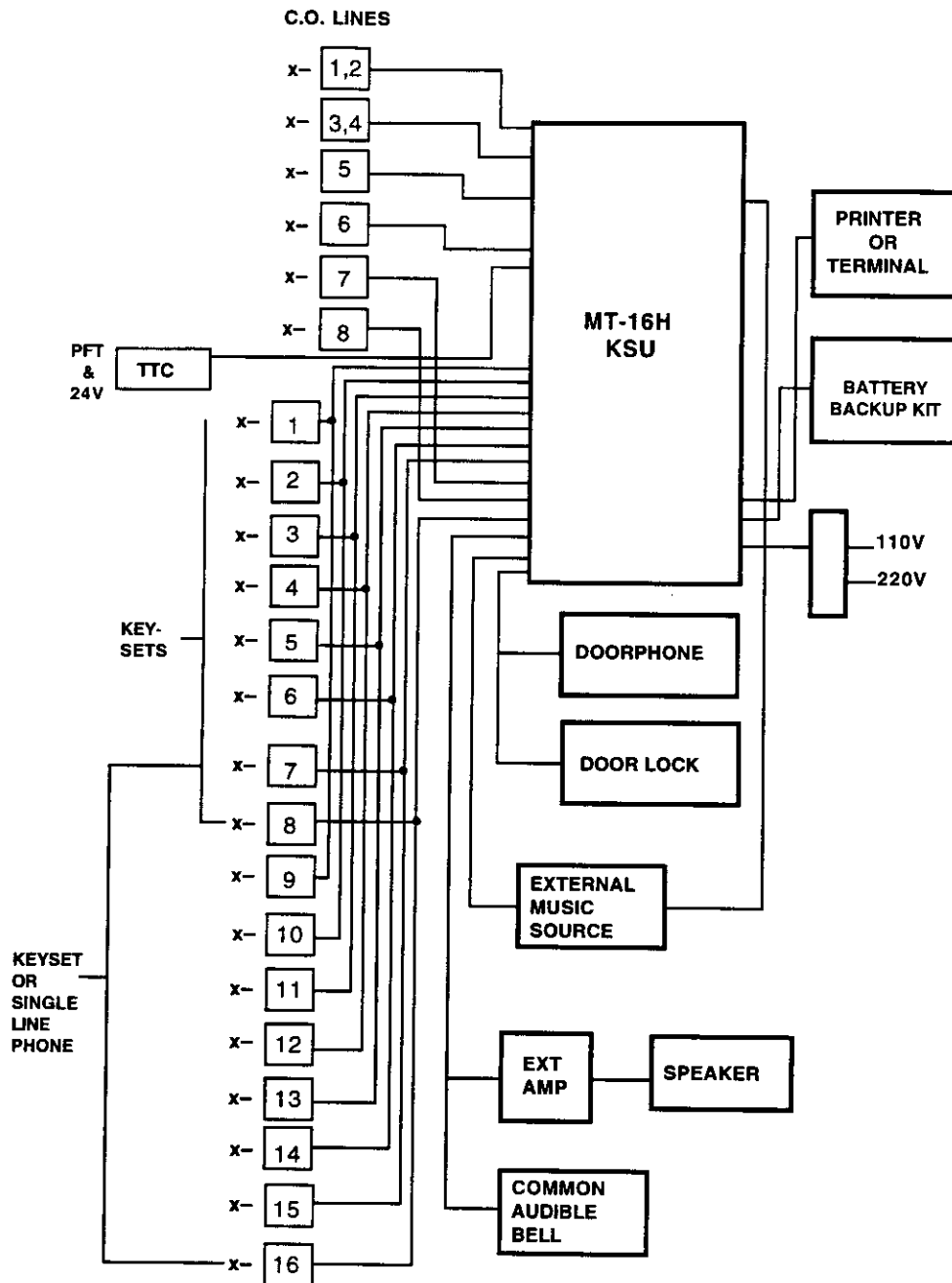

FIGURE 5

4.0 MT-16H FEATURE DESCRIPTIONS

Account Code ***	Non verifiable account codes can be entered while on an outside call. 7 digit maximum including [*] and [#]
All Call Paging	A station user can page all stations simultaneously by depressing his or her own DSS key.
Alphanumeric Display	An LCD kit is available to be installed on a phone. The display is 16 characters.
Appointment Alert	The user can program his or her own phone to remind them with a series of tones at a predetermined time.
Assignable DND***	The Do Not Disturb feature can be allowed or denied on a per station basis.
Attendant Camp-On	The attendant can camp a call on to a busy station.
Attendant Direct Access	Station users have direct access to the attendant simply by depressing a DSS key or dialing [0].
Attendant Recall**	When the hold/exclusive recall timer expires, the attendant recall timer will start and the user's phone will recall for 30 seconds before recalling to the operator.
Automatic Hold	While on an outside line, the user places it on hold automatically by pressing a DSS or the PAGE key.
Automatic Pause Insertion	A pause is automatically inserted when using the redial feature to ensure that dial tone is present before the system dials the telephone number.
Automatic Privacy	All outside line calls are private.
Automatic Recall	A transferred call automatically recalls the originating station after a period of time.
Automatic Redial	The system will automatically redial a busy telephone number up to 3 times at 45 second intervals (up to 99 attempts**).
Automatic Trunk Queuing	The system will automatically call a user's station when the line he or she has queued on becomes free.
Background Music	Music can be played through the speaker of a user's phone while it's not in use.
Battery Backup, Memory	System and user programming is safe even during an extended power failure.
Battery Backup, System	The system can continue processing calls during a power failure (optional).
Boss/Secretary Hotline	A hotline can be setup between a boss and secretary. If the boss activates the Do Not Disturb feature, all intercom calls are forwarded to the secretary.
Built-In Directory	A directory holder comes with each phone to display important numbers to the user.
Busy Lamp Field	A user can tell when another user is busy by observing the status of the LED on the DSS keys of his or her telephone.
Busy Station Callback	A user can queue onto a busy station and be called back when the station becomes available.
Call Forwarding	Users can forward their intercom calls to another station (ICM, outside line or both**).

Call Pickup, ICM and CO	A call can be picked up from your phone even though it may be ringing on someone else's phone.
Call Offering	Allows you to notify a busy station of another call.
Call Offering Alert**	After Call Offering has been activated, a repeated tone is provided to the called party each time the DSS key is depressed.
Camp-On Busy/No Answer	A station user can camp a call onto a station that's busy or does not answer. The user can also camp-on to the busy station so that when the called party hangs up or returns to his phone the calling station is alerted.
CO Flash Capability	The system is capable of sending an adjustable flash for PBX and CENTREX features.
CO Line Pickup	An outside line can be picked up with a dial code, even if it doesn't appear on your phone.
Common Audible Ring**	This feature allows the system to direct incoming calls to an external bell, in addition to their normal day/night ring assignments.
Conference Calls, 5 Party	Up to 5 parties can be conferenced together in any combination of outside lines and inside parties.
Conference Rejoin ***	The originator of an unsupervised conference can rejoin the conference.
Date/Time Display*	The optional LCD kit displays time and date when the phone is not in use.
Dial Pulse or DTMF Selection	The system will operate with dial pulse or DTMF lines.
Dial 9 Group	Outside lines to be accessed by dialing 9 can be specified.
Dial 7 Group**	Outside lines to be accessed by dialing 7 can be specified.
Display Dialing Number*	The LCD displays the telephone number you've dialed, even speed dial numbers.
Display Calling Intercom*	The LCD displays the intercom number and name of the station that is calling you.
Display Message Wait Caller Number*	The LCD will display the station number that left you a message waiting indication.
Direct Station Selection	You may place an intercom call with the touch of one button (DSS).
DISA***	An outside caller can talk to an internal party or, with a password, access an outside line to place a call.
Disconnect Warning Tone ***	During external call forward, unsupervised conference and DISA calls, a warning tone is heard 15 seconds before the line is disconnected. At that time, the user can override the disconnection.
Discriminating Ringing	Intercom ringing and outside line ringing are different for ease of identification.
Doorphone	The MT-16H system has 1 doorphone circuit. (Standard on main PCB).
Door Release Relay	Allows the user to open a door lock.
Do Not Disturb	A user may stop intercom calls to his or her station with the do not disturb feature.
DTMF Muting	The system can be programmed so the user does not have to hear the DTMF tones.
DTMF on Transfer**	Keypad users may now perform a screened transfer into a voice messaging system and enter required digits for personal greeting of a specific mailbox before hanging up.

DTMF Over Page ***	DTMF tone can be sent over the page circuit for special paging applications.
Dual Color CO LED's	Dual color LEDs help the user keep track of calls.
Dual Level Passwords ***	Two passwords are available, one for system programming and one for user programming.
E&M Trunks	The system supports 2-wire E&M Type 1 Tie lines (up to 4 max.).
Exclusive Hold	A call can be put on exclusive hold so that only the station that put the call on hold can retrieve it.
Executive Priority (Override)	Specially classed stations are able to intrude into existing telephone conversations.
External Call Forwarding	The system can be programmed to forward incoming calls to another outside location.
Flexible Ringing Assignment	Outside lines can be programmed to ring at different phones in the system.
Group Listening ***	While on an outside call, the outside parties voice can be heard from the speaker of the telephone.
Handsfree Answer Back	A user can respond to an intercom call without touching his phone.
Headset Hookswitch Control	Through programming, the speaker key operates hookswitch control when a headset is installed.
I-Hold and I-Use Indications	Distinctive LED flash rates make it easy to see what lines are in use and which ones are holding.
Incoming Call Distribution	Multiple stations arranged to receive incoming ringing may be programmed to allow the distribution of inbound calls in a circular hunt fashion.
Interface for External Music Source	A music source may be installed for music on hold and background music. Internal music source is standard. External music requires customer supplied source.
Interface for External Paging	An external page network can be setup for areas like large warehouses.
Internal Page Zones ***	A station can be a member of one of three page zones and all call page.
Last Number Redial, One Button	The last number dialed may be redialed with the press of one button.
Line Queuing Callback	A user can queue onto a busy outside line and then be called back when it becomes available.
MacroVoice MVX Compatibility	The MT-16H was designed to work with the MacroVoice MVX Series.
Meet Me Page ***	The paged party may answer the caller from any phone by dialing a code. An outside line may be processed with the meet me page feature.
Message Waiting	A station may leave an indication on another station's phone to alert the user that they need to speak with them.
Music On Hold (Internal)	An internal music source is provided for music on hold.
Music on Hold (External)	With an external music source, callers placed on hold can listen to radio or taped music.

Microphone Mute	The speakerphone microphone can be muted so the calling party cannot hear the user.
Night/Day Ringing Assignment	Different stations can be programmed to ring in day and night mode.
Night Transfer	The attendant can redirect ringing assignments by activating night transfer.
Non Private Line Application ***	The MT-16H can be configured with or without privacy on the C.O. lines to meet the customer's needs.
Off-Hook Signalling	While busy on another call, a tone alerts the user of another call ringing in.
Optional Class of Service	After normal business hours, the operator may set a master instruction which reassigns all stations into a toll-restricted class of service. (Exception stations are unaffected**)
Outgoing Call Restriction by Station Class	Various levels of outgoing call restriction are programmable on a per station basis.
Pre-Selection	A user may select an outgoing line before lifting the handset and the speaker turns on automatically.
Prime Line	The user can choose between automatic outside line or ICM when the handset is lifted.
Privacy Release	Privacy on outside lines may be released to allow other users to join your conversation.
Private CO Line	An outside line can be made private by denying all other users access to it.
Processing Second Call**	This feature allows a station to more efficiently process calls by eliminating the need to go on hook to complete a transfer.
Programmable Function Keys	Many features may be programmed under the DSS keys.
Programmable Timing Parameters	Many timers, such as hold recall time, are programmable to meet the users particular needs.
Recall Identification*	From a display set, any returning calls from the transfer condition will indicate the type of call and station involved in the original transfer such as hold recall and transfer recall.
Ringin Line Preference ***	A user can choose between having to press the line key to answer a ringing line or answer simply by lifting the handset.
Rotary Dialing to DTMF Tone Sender Changeover	This feature enables the user to change from pulse dialing to DTMF tone sending while dialing a telephone number. (Very important for voice mail applications).
Save Last Number Dial	This feature enables the user to store a number, which may be frequently dialed within the course of a day, and retrieve this number for dialing at any time.
Single Line Station Compatibility	Up to 10 single line telephones may be installed on the MT-16H. (DTMF of Rotary).

Single Line Transfer (Recall to Operator)**	When a single line station user transfers a C.O. line to an unanswered destination, after the transfer recall timer, the call will return to the originator or operator (programmable).
Speakerphone	All telephones incorporate standard speakerphones for both inside and outside calls.
Speakerphone Volume Control	The volume of the voice emitting from the speakerphone is changeable with a slide control located on the face of the telephone.
Speed Dial Privacy	Ten bins of the system speed dial and 2 bins of a users personal speed dial will not display the number programmed. This prevents users from seeing the programmed number.
Splash Tone	The user is warned with a splash tone when an intercom call arrives.
Speed Dial, Station and System	The system has 90 system speed dial numbers and each user has up to 16 personal speed dial numbers.
Speed Dial, Chain Dialing	You may dial an additional telephone number manually after a speed dial. You may also access more than 1 speed dial number.
SMDR	Station Message Detail Reporting is standard.
Station Hunt Group ***	Three Station Hunt Groups can be created. A Hunt group can have a maximum of 8 stations. A station can be in only one group.
Status Message Display*	A user leaving their telephone may select a message to be displayed to a calling intercom user. Ten (10) messages are preprogrammed and 10 more are programmable.
Station Name Display*	The user's name can be displayed on the LCD.
Stop Watch Timer*	The LCD may be used as a stop watch on an idle phone.
System Hold	A call placed on system hold may be retrieved from any phone.
System Programming with Password	For security, a password is required to enter into system programming.
Timer *	The call timer will automatically begin in a predetermined amount of time after the outside line is seized. The timer information can be displayed on your phone.
Tone Ringer Control	A 3-position switch is located on the base of the telephone to control the volume of all tones emitted from the phone.
Toll Restriction	Multi-level toll restriction is programmable on a per station basis.
Traveling Class of Services	The system will permit override of toll restriction for a toll-barred phone through the use of a special security code. (Single line phones included**)
Unsupervised Trunk Conference	A conference established with one or more trunks will be permitted to remain engaged without the presence of an internal station on the circuit.
Voice Signaling	A voice announcement may be made to an idle station.

*Display Telephone
**MV2
*** MV3

5.0 INSTALLATION

OVERVIEW

To complete the installation of the MT-16H and associated equipment in a timely and efficient manner, it is essential to establish a complete installation plan. Be sure to complete the customer data programming sheets before getting started.

The following sections offer a detailed documentary and pictorial view on installation of the equipment with notes, as needed.

Please completely read through the Installation and Programming Sections before attempting to install the equipment.

INSTALLATION PRECAUTIONS

- DO NOT run cables parallel to fluorescent light fixtures or AC lines. If unavoidable, run the cable across at 90 degree (right) angles.
- DO NOT run station cables inside electrical conduit already occupied by an AC power cable. This will induce AC voltage into the cable and also is in violation of the National Electrical Code.
- DO NOT exceed 66 OHMS or 1310' (400M) with AWG 24 cable on keysets. For single line telephones, DO NOT exceed 480 OHMS, including the telephone, or 5000' (1525M) with AWG 24 cable.
Note: See page 16 for more information.
- Avoid installing in the following places. (Doing so may result in malfunction, noise, or discoloration)
 - A. In direct sunlight and hot, cold, or humid places.
(Temperature range: 41°F (5°C) - 104°F (40°C))
 - B. Due to sulfuric gases produced in areas where there are thermal springs, etc., damage to the equipment or contacts may occur.
 - C. Places in which shock or vibration are frequent or strong.
 - D. Dusty places, or areas where water or oil may come into contact with the unit.
 - E. Near high-frequency sewing machines, electric welders, copy machines or motors.
 - F. On or near computer, telexes, or other office equipment, as well as microwave ovens or air conditioners. (It is advisable not to install the system in the same room with the above equipment)
 - G. Near radio broadcast antennas (including short wave).
 - H. Install at least 5 feet from radios and televisions.
- DO NOT OBSTRUCT THE AREA AROUND THE KSU FOR REASONS OF MAINTENANCE AND INSPECTION. (BE ESPECIALLY CAREFUL TO ALLOW SPACE FOR COOLING ABOVE AND AT THE SIDE OF THE KSU)

EQUIPMENT VERIFICATION

Verify that all components on the packing slip are included in the boxes. For reference, utilize the chart below to assure that all components have been received. Any damaged material should immediately be reported to the carrier. Report any discrepancies of required equipment to MacroTel International Corporation.

SYSTEM COMPONENTS MT-16H		
UNIT	PART NUMBER	DESCRIPTION
408 KSU	2609100	Electronic Switching System
MT-16T	2609102	8 Line/16 Station Speakerphone
LCD Display	2609105	LCD Display Module
WMK	2609113	Wall Mount Kit
Battery Backup Kit	2208037	Wall Mount Kit, associated cables
MT-STU/A	2609106	2 C.O./4 keyphone expansion card
MT-STU/B	2609107	2 C.O./4 SLT expansion card
MT-STU/C	2609108	2 C.O. or /2 E&M/4 keyphone expansion card
SMDR	2609109	SMDR PCB
Doorphone	2609110	Doorphone Unit

INSTALLATION LOCATION CHECKLIST

1. Select the KSU location to minimize station cable run lengths. DO NOT exceed measurements of 66 OHMS or 1310' (400M) using 24 AWG wire for keysets. Single line telephones should not exceed 480 OHMS, including the telephone, or 5000' (1525M) using 24 AWG wire. The OHM value is the loop measurement. The length is the maximum one way measurement from the KSU.
2. Select a wall that is strong enough to support twice the weight of the equipment and plywood to be mounted.
3. The main distribution frame (MDF) requires a maximum 3x4 foot, 3/4 inch plywood backboard. The KSU is mounted on this backboard, along with connecting block(s) and modular jack assemblies. Allow room near the KSU for the paging amplifier, battery backup equipment and the external music source, if used. To avoid interference, the music source should be placed a minimum of 5 feet away from the KSU.

Place the KSU within 9 feet of an isolated, dedicated, 110/220 VAC, single-phase, commercial power source. DO NOT use an extension cord. This MUST be an isolated, dedicated, AC circuit for proper operation. The ground wire must be dedicated to this outlet. Run the power, neutral and ground wires directly from a separate circuit in the breaker box to the KSU outlet. DO NOT plug any other equipment into this outlet. Make sure there are AC outlets for a music source and a paging amplifier, if they are to be installed. These outlets MUST NOT be on the same circuit as the outlet for the KSU.

Prepare a floor plan for the keysets/slt locations using a star (home-run) configuration. Include each keyset's intercom number 1-16. Intercom number 4 is assigned to the system attendant in default software programming.

The system location should not be exposed to direct sunlight, high humidity, heat, dust or strong magnetic fields (such as heavy motors or large copy machines).

Simple air space should be provided for the KSU since the power supply is convection cooled. DO NOT block the cooling vents located on the KSU. Never place anything on top of the KSU.

TOOLS CHECKLIST

1. A high-impedance, digital multimeter is required to ensure the correct wiring and voltage on the keyset modular jack assembly.
2. Standard telephone hand tools.
3. 2-pair (4 conductor) twisted cable to run from the MDF to each keyset/slt location.
4. 4-conductor modular jack assemblies for terminating the station cables at keyset/slt location.
5. Punch down tool, Phillips head screwdriver, flat head screwdrivers, and drill and bit set.

MT-16H FACILITIES LOCATION

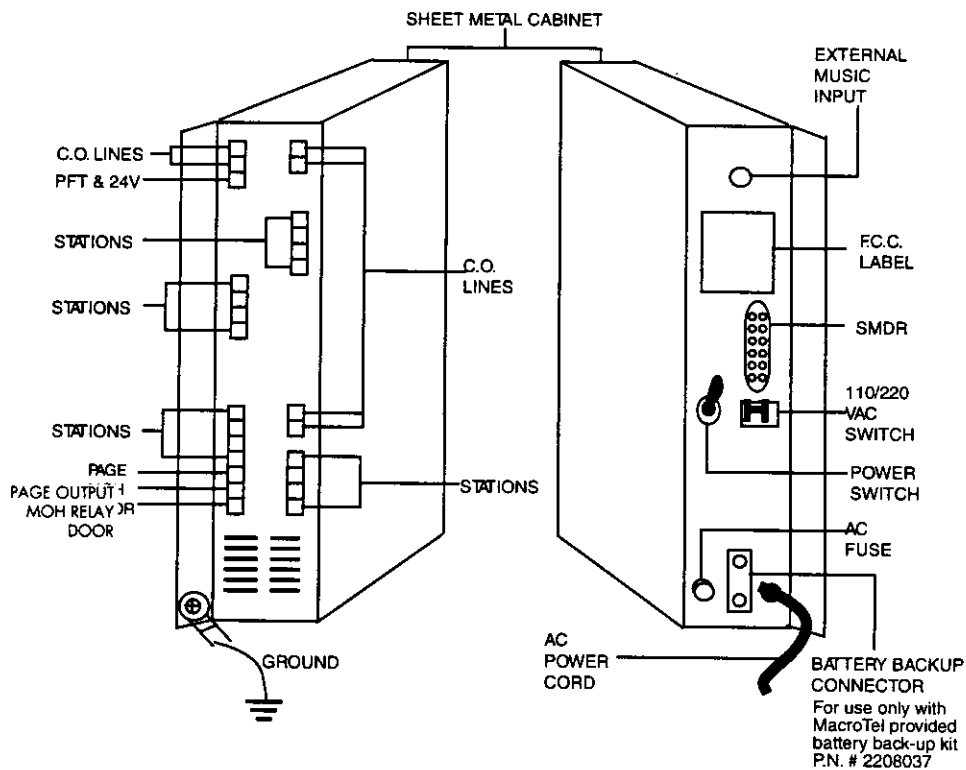

FIGURE 6

MAIN DISTRIBUTION FRAME (MDF)

Plan the location for the 66 blocks, central office connectors, KSU and any other assemblies included in the installation. **BE SURE TO CONNECT THE FRAME GROUND**

STATION CABLES

Using the floor plan developed in pre-installed planning, run 2-pair twisted cable (3 pair if installing off hook voice announce unit) from the MDF to each keyset/slt location. Label both ends of every cable with the keyset/slt intercom number (1~16).

Avoid cable runs parallel to fluorescent light fixtures or AC lines not in conduit. If these obstacles are unavoidable, run the cable across them at right angles.

DO NOT run station cables inside electrical conduit already occupied by the AC power cable. To do so is a violation of the National Electrical Code.

DO NOT run station cables near equipment with electronic motors or past strong magnetic fields (copy machines, heavy motors, welding equipment, etc.).

DO NOT place station cables where they can be rolled over by office furniture or stepped on.

DO NOT allow the station cable length to exceed 66 OHMS or 1310' (400M) using 24 AWG wire. For single line telephone do not exceed 480 OHMS, including the telephone, or 5000' (1525M) using 24 AWG wire. The OHM value is the loop measurement; the foot (meter) length is the maximum one-way measurement from the KSU.

TERMINATING STATION CABLES AT THE MDF

Terminate each station cable at the MDF as described below:

1. Mount the station 66 block assembly on the MDF backboard.
2. Ensure that each station cable is correctly labeled with the keyset/slt intercom number.
3. Using the punch down tool, terminate the cables for each set.

TERMINATING STATION CABLES AT KEYSSET/SLT LOCATIONS

Terminate the keyset/slt end of each station cable on a 4-conductor modular jack assembly as shown in Figure 10.

CENTRAL OFFICE LINE

Assure that the central office lines have been installed on the backboard. These lines will be connected to the KSU with modular cords supplied with the KSU. Follow the diagram on Figure 11.

KEY SERVICE UNIT

BEFORE MOUNTING THE KSU

Unpack the KSU and lay it on a flat surface with the cover facing up. Open it by removing the four retaining screws and lifting off the cover. The PCBs contain static-sensitive components. Lift them only by the edges and carefully handle the components while inspecting them in the next step. Always use a static wrist strap for protection.

Inspect the fuses for the correct voltage and current rating. The AC fuse (1A, 250V, fast-acting) is accessible from the outer right side of the KSU.

Ensure that the ROM integrated circuits are properly seated in their sockets.

If the KSU or any of its components are damaged, contact MacroTel International Corporation.

******IMPORTANT******

You **MUST** activate the NICAD battery by setting the **BACKUP** switch (Dip Switch 2) to the "ON" position. Otherwise, the database memory will not be protected during a power outage. Refer to Figure 22 for location of backup switch.

MOUNT THE KSU

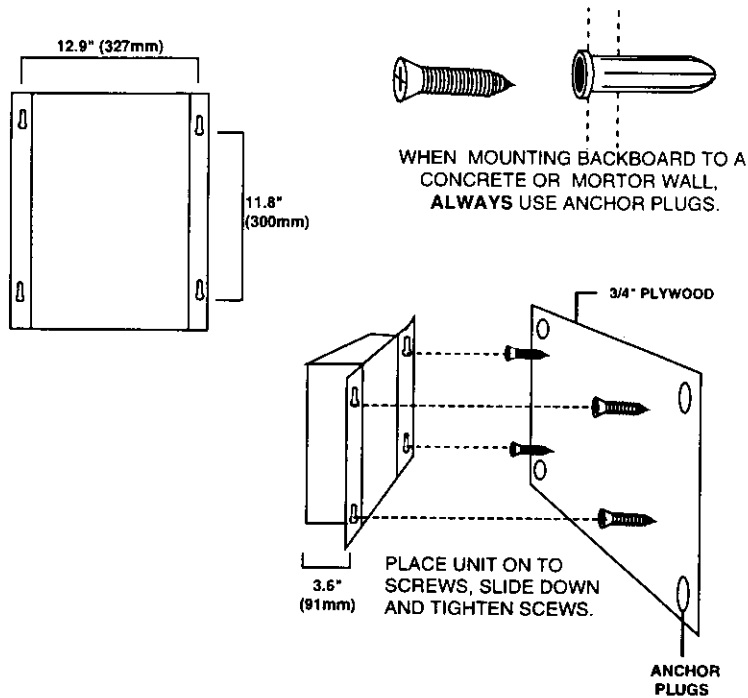
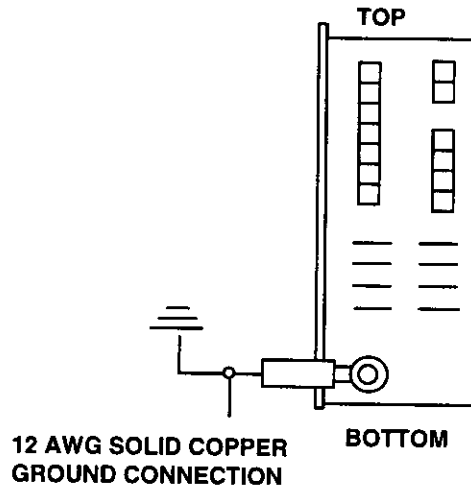

FIGURE 7

FRAME GROUND CONNECTIONS



FIGURES 8

110/220 VOLTAGE CONNECTION:

1. Determine the proper voltage of the AC wall receptacle using a meter, if necessary.
2. Move the switch on the side of the KSU to the proper voltage selection.

INSTALLING THE KEYSETS/SLT

Unpack and inspect each keyset for damage. Along with the keyset, the box should contain a 6-foot line cord, a coiled handset cord, a handset, and a plastic bag of key designation labels.

With the KSU AC power "ON", check the voltage on each modular jack assembly as follows:

Keyphone

- a. Measure the voltage on the YELLOW (+24) terminal with respect to the RED (GND) terminal. Place the common probe of the voltmeter on the RED terminal. It must measure +24V, ± 5 VDC. If -24VDC is measured, check the cabling for a reversed pair.
- b. Check the voltage on the BLACK (+24) and GREEN (GND). The voltage condition is the same.

Single Line Telephone

- a. Check the voltage on the RED and GREEN. The voltage should be +24VDC, ± 5 VDC. If -24VDC is measured, check the cabling for a reversed pair.

Connect all keysets to their respective connectors with the provided modular cord.

TO CONNECT EACH STATION TO KSU

1. Plug the modular cord supplied with the KSU into the modular plug labeled Station Number 1.
2. Connect the wires at the other end of the cord to a connecting block. See Figure 10.
3. Use the same procedure as described above for connection of Station Numbers 2 through 16.
4. As Station Number 7 and 8 are available for keyset/slt, make sure that the DIP switches located on the main PCB are set as shown in Figure 9.
5. In order to connect Station Numbers 9 through 16, expansion cards MT-STU-A, B or C must be installed. See Figure 13.

Note: Program Item 38 is also required to activate single line telephones.

DIP SWITCH SETTING FOR STATIONS 7 & 8

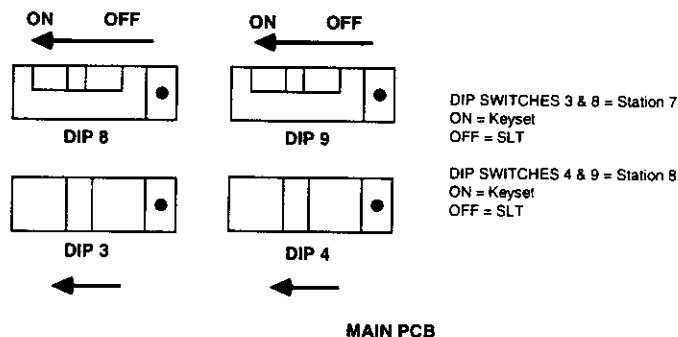

FIGURE 9

STATION CABLING FOR SINGLE LINE PHONE

Single line telephones should be wired exactly like the keysets to allow for easy upgrading to keysets.

CONNECTION OF KEYSETS AND SINGLE LINE TELEPHONES

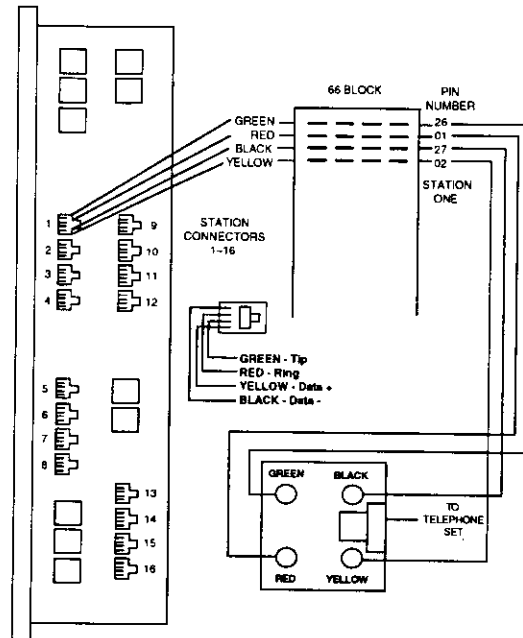

FIGURE 10

Note:

1. Use 2 or 3 pair twisted wire to prevent the possibility of crosstalk.
2. Review Installation Precautions as listed on Page 15.
3. Stations 9-16 require the installation of MT-STU/A, B or C. See Page 23-24.
4. Single line telephones require only tip and ring but it is recommended to wire single lines just like keyphones so that future upgrading is easier for the installer.

CONNECTING CENTRAL OFFICE LINES 1, 2, 3 AND 4

1. Plug the modular jack at one end of the 2-pair cable supplied with the KSU into the connector for lines 1 and 2.
2. Connect the other end to the outside lines through the connecting block according to Figure 11.
3. Use the same procedure for connection of C.O. lines 3 and 4.

TO CONNECT C.O./E&M TIE LINES 5, 6, 7 AND 8 (Expansion Card Required)

See installation expansion cards, pages 23~24.

1. Plug the modular jack at one end of the 2-pair cable supplied with the expansion card into the connector for Line 5.
2. Connect the other end to outside line through the connecting block according to Figure 11.
3. Use the same procedure for connection of C.O. Lines 6,7 and 8 respectively.

CONNECTION OF CENTRAL OFFICE LINES/ E&M TIE LINES

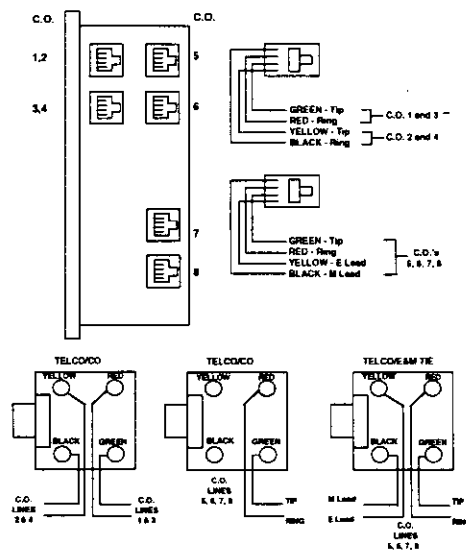

FIGURE 11

Notes:

1. For Central Office lines in positions 5,6, 7 or 8, MT-STU/A, B or C must be installed. For E&M Tie lines in positions 5,6,7 or 8, MT-STY/C must be installed.
2. Incorrect wiring of C.O. may cause malfunction. If so, refer to Troubleshooting Section. MT-STU/A provides 2 C.O. lines and 4 key telephone circuits.

MT-STU/A provides 2 C.O. lines and 4 key telephone circuits.

MT-STU/B provides 2 C.O. lines and 4 single line telephone circuits.

MT-STU/C provides 2 C.O. lines or 2 E&M tie lines and 4 key telephone circuits.

SWITCH SETTINGS FOR MT-STU-C

DIP SWITCH	11	12	13	14	15		DIP SWITCH	21	22	23	24	25
C.O.	0	1	0	0	ON	} 5 or 7	C.O.	0	1	0	0	ON
E&M	1	0	1	1	OFF		E&M	1	0	1	1	OFF

FIGURE 12

TO INSTALL EXPANSION CARDS

1. Remove the 4 screws from the main PCB and replace them with the standoffs supplied with the expansion board.
2. Position the expansion card so that the modular jacks appear on the left side of the KSU.
3. Plug the ribbon cable into the proper connector on the main PCB.
4. Secure the expansion card with the 4 screws previously removed.
5. When installing the expansion card towards the top of the main PCB, C.O. lines 5, 6 and Stations 9, 10, 11 and 12 are added. When installing the expansion card towards the bottom of the main PCB, C.O. lines 7, 8 and Stations 13, 14, 15 and 16 are added.

INSTALLATION OF EXPANSION CARDS

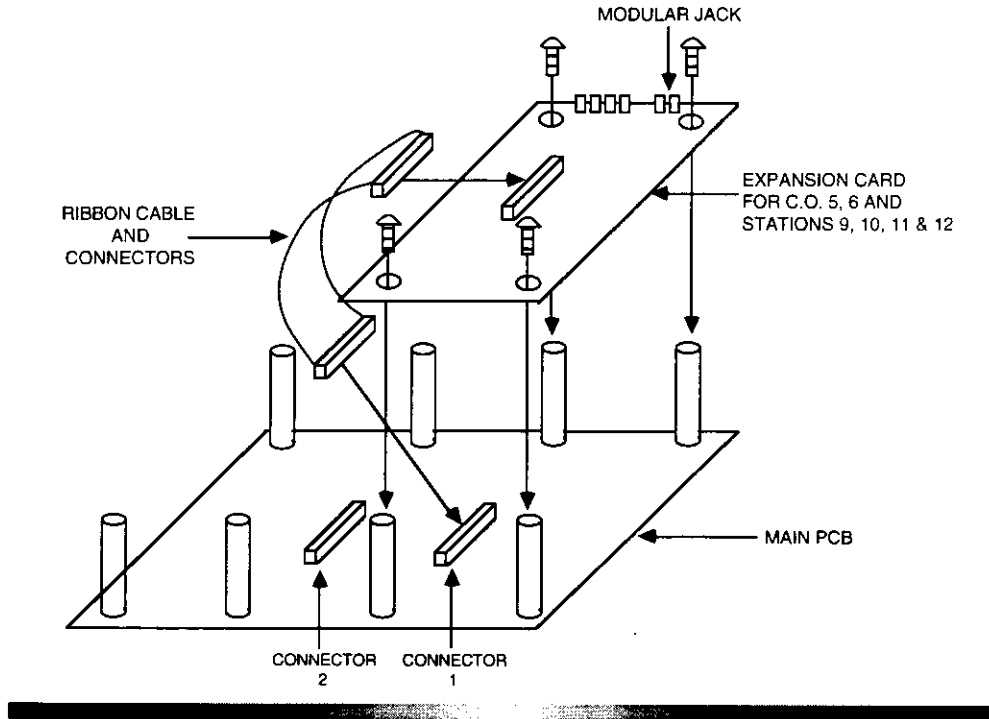

FIGURE 13

CONNECTING EXTERNAL PAGING SPEAKERS

1. Plug the modular cord supplied with the KSU into the modular plug labeled PAGE.
2. Connect the Voice pair (blue & yellow wires) to the 600Ω input of the amplifier.
3. The black and white wires are dry contact points that can be used, for example, to mute background music over page. Connect the black and white wires to the mute terminals of the amplifier. (The relay can also be used to ring a bell during Common Audible Ring**)

Note: Connect only DC voltage to the black and white wires. KSU relay rating is 24 vdc, .5 amp.

CONNECTING THE DOORPHONE AND DOOR LOCK CONTROL

1. Plug the 3-pair modular cord supplied with the KSU into the modular plug labeled DOOR.
2. Connect the Voice pair (blue & yellow wires) and the power pair (green & red wires) to the back of the doorphone.
3. The black and white wires are dry contacts used to operate a customer provided electric door lock unit.

Note: Connect only DC voltage to the black and white wires. Use a slave relay if the door lock unit requires AC. KSU relay rating is 24 vdc, .5 amp. 330 (100m) with 24 AWG. See Figure 14.

** = MV2

EXTERNAL PAGE AND DOORPHONE CONNECTIONS

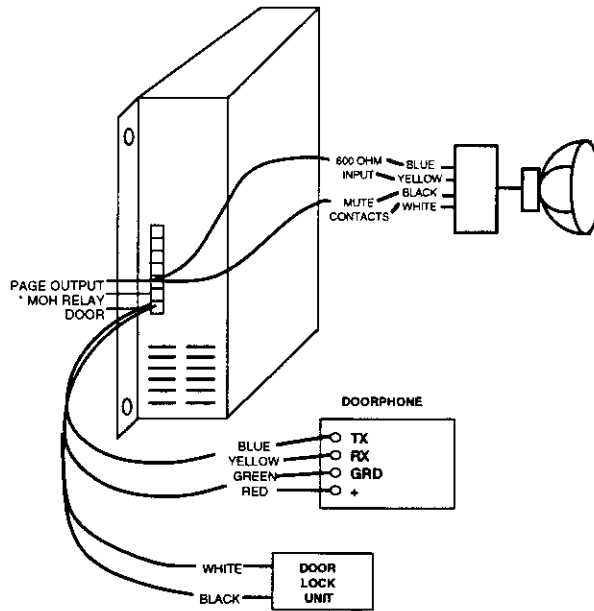

FIGURE 14

Note: This Music on Hold connection is used to turn the external source audio output on and off. When no calls are on hold, the source is turned off. The yellow/black wires perform this function. Apply no AC voltage to the contacts. Use only DC voltage and a slave relay.

The black and white wires on the Page circuit can also be used to operate a bell or some other device during Common Audible Ring Mode. KSU relay rating is 24 vdc, .5 amp.**

** = MV2

INTERNAL MUSIC SOURCE

The internal music source of MT-16H has two selections.

TO CHANGE INTERNAL MUSIC SOURCE

1. Refer to Figure 15.

CHANGE INTERNAL MUSIC SOURCE

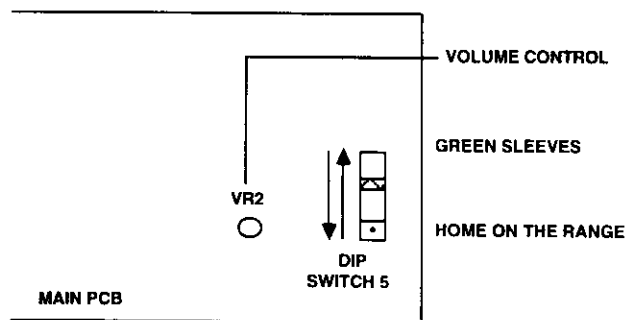

FIGURE 15

EXTERNAL MUSIC SOURCE

Although the MT-16H is provided with an internal music source, an external music source such as a radio or tape player can be connected to the system.

TO CONNECT AN EXTERNAL MUSIC SOURCE

1. Connect the external music source to the external music jack using a 1/8 in. (3.5mm) mini phono plug. See Figure 16.
2. Impedance 600 OHMS. 250 mvolts maximum. Caution: Over voltage may cause damage to MOH circuit.

MUSIC ON HOLD CONNECTIONS

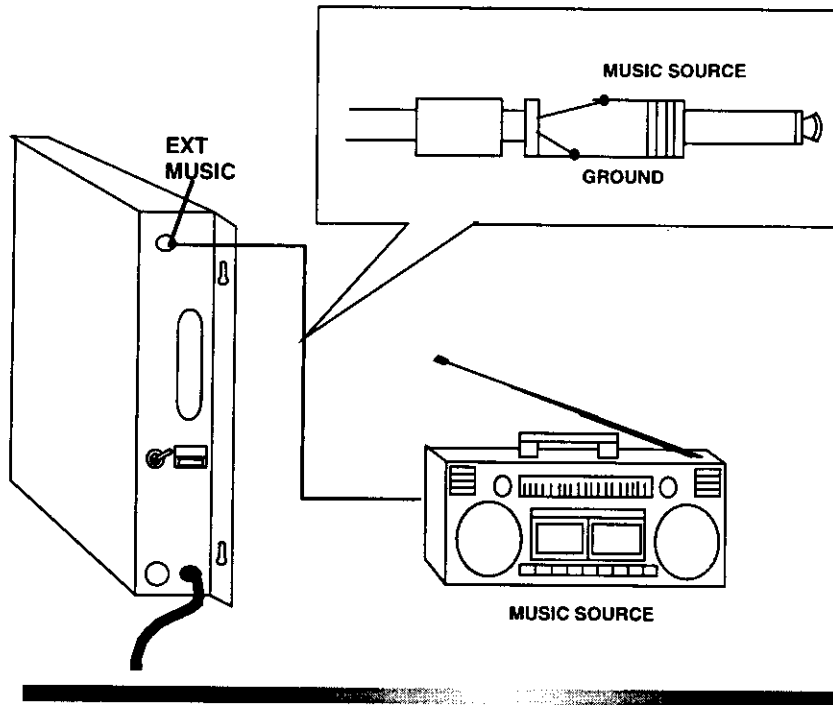

FIGURE 16

Note:

1. The MOH plug between the page and the doorphone modular plug (Figure 14) is used to turn the external music audio output on and off. The yellow/black wires perform this function. When no calls are on hold, the source is turned off. No AC voltage. DC voltage only with slave relay! KSU relay rating 24 vdc, .5 amp.
2. Always used shielded cable.
3. Do not connect radio source to same AC outlet as KSU.
4. Locate music source a minimum of five (5) feet away from KSU to prevent RFI interference.
5. For no music on hold or background music disconnect connector 5 from main PCB.

CONNECTING A PRINTER OR TERMINAL (SMDR)

A printer or terminal for the purpose of station message detailed recording can be connected to the MT-16H. To enable this feature, the optional SMDR card must be installed into the system. An RS-232C connector and cable are required for connection of the printer or terminal.

- A. Install the two plastic standoffs provided with the SMDR card into the KSU base.
- B. Insert the RS-232C connector through the hole in the KSU labeled SMDR.
- C. Align the SMDR card with the connector on the main PCB and the standoffs. Press card into place.

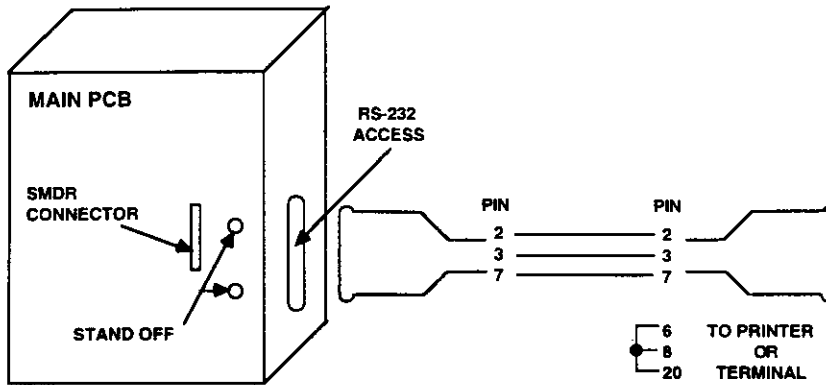

DIP SWITCH SETTING

		4800 bps	2400 bps	1200 bps	600 bps
DIP 1	2	ON	OFF	OFF	OFF
	1	OFF	ON	OFF	OFF
DIP 2	2	OFF	OFF	ON	ON
	1	OFF	OFF	OFF	ON

Serial collection device settings:

- * Even Parity
- * 8 bits
- * No start or stop bit

SMDR FORMAT

STN XX	CO X	MM/DD XX:XX	STT.TIME HH:MM:SS	DURATION HH:MM:SS	DIAL NUMBER 18 Digits Max.	ACCOUNT CODE
-----------	---------	----------------	----------------------	----------------------	-------------------------------	-----------------

FIGURE 17

POWER FAILURE TRANSFER

The MT-16H provides up to 6 PFT circuits. On the main PCB, station 7 and 8 can be configured as PFT circuits.

- If stations 7 and 8 are being used as single line stations on the system, they will automatically be connected to C.O. lines 1 and 2 respectively if dip switches 6 and 7 are set as follows:

Dip 6 - ON = C.O. 1 to SLT 7
 Dip 7 - ON = C.O. 2 to SLT 8

- If stations 7 and 8 are being used as key telephones on the system, C.O. lines 1 and 2 will be automatically connected to 2 single line telephones connected to the TTC plug on the left side of the KSU. For this scenario to operate, dip switches 6 and 7 are set as follows:

Dip 6 - OFF = C.O. 1 to Tip 1, Ring 1
 Dip 7 - OFF = C.O. 2 to Tip 2, Ring 2

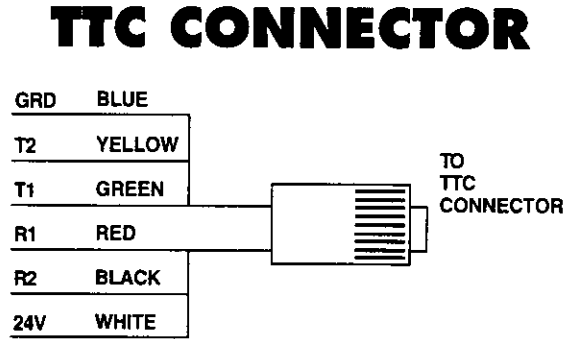

FIGURE 18

Note: In scenario 2 the SLT's do not operate until power has failed. Any device connected to the 24V power source must draw no more than 12.5 mA.

- When using the MT-STU/B, the first 2 single line circuits are automatically connected to the C.O. lines served by the MT-STU/B. For example:

MT-STU/B #1	MT-STU/B #2
C.O. 5 goes to SLT 9	C.O. 7 goes to SLT 13
C.O. 6 goes to SLT 10	C.O. 8 goes to SLT 14

*No dip switch settings are required for scenario 3.

BATTERY BACKUP

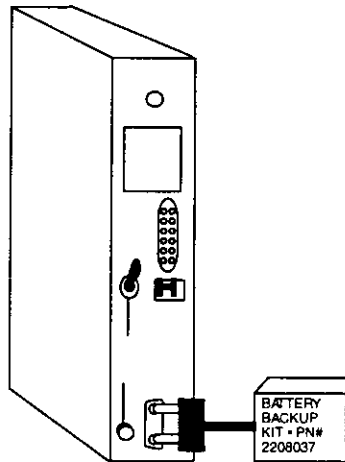

FIGURE 20

LCD DISPLAY KIT INSTALLATION

CAUTION - USE A STATIC WRIST STRAP WHEN PERFORMING THIS INSTALLATION.

1. WITH THUMBS ON FRONT OF COVER PLATE, PRESS FINGERS GENTLY ON BACK OF COVER PLATE AND LIFT.
2. LOCATE RIBBON CABLE INSIDE PHONE.
3. BEING CAREFUL NOT TO PULL ON RIBBON CABLE, INSERT CABLE INTO THE CONNECTOR OF THE DISPLAY KIT. ENSURE THAT THE RIBBON CABLE CONDUCTORS ARE TOUCHING THE CONNECTORS CONDUCTORS.
4. GENTLY "SNAP" THE DISPLAY KIT INTO THE PHONE FRONT PART FIRST, THEN BACK.

MT-16T TELEPHONE LCD INSTALLATION DIAGRAMS

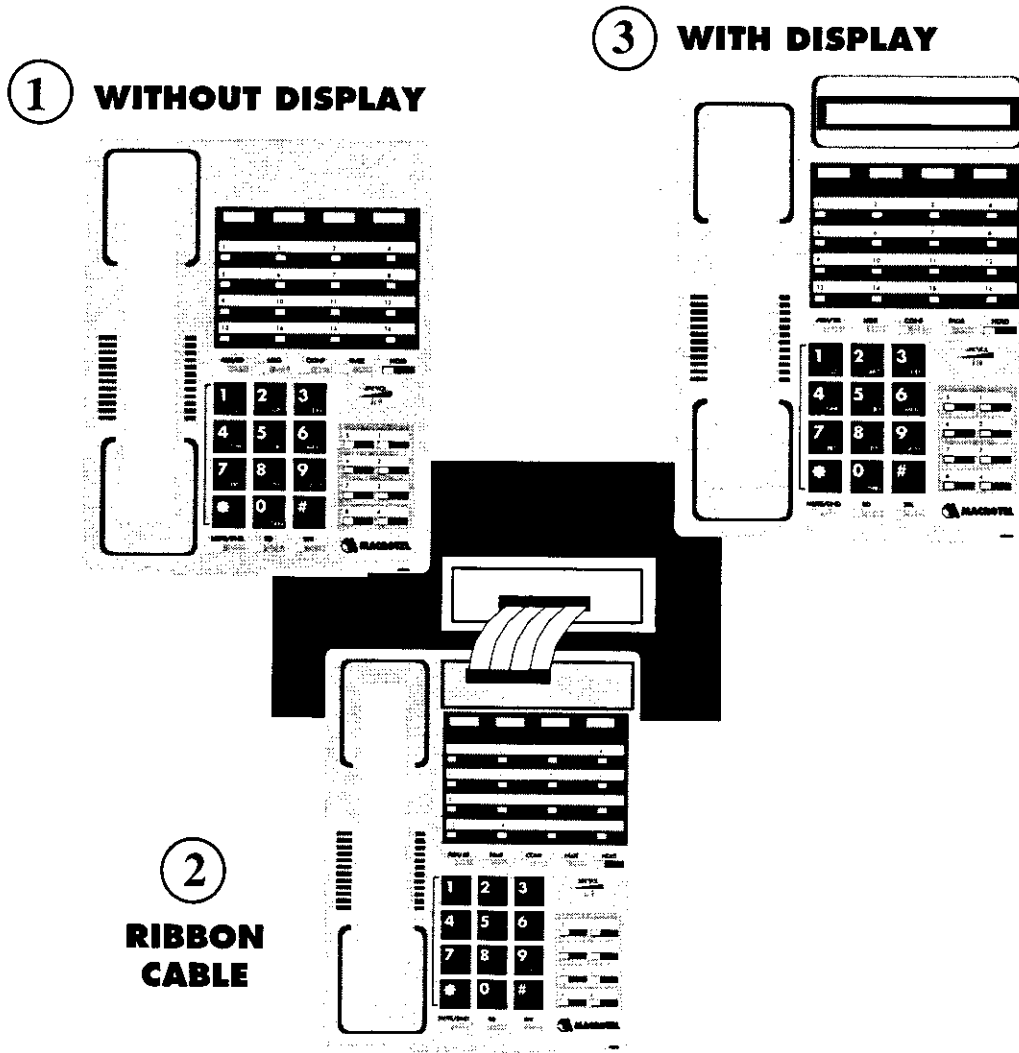

FIGURE 21

MEMORY BATTERY INITIALIZE

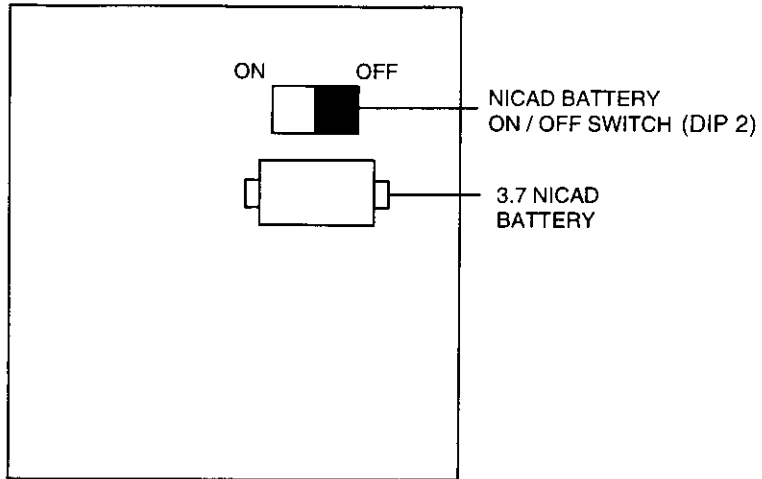

FIGURE 22

NOTE:

1. Remove the cover from the unit.
2. Locate the battery ON/OFF switch and turn the switch "ON". (Dip 2)
3. The battery will normally last approximately 40 hours during power outage, if it is fully charged.