

ST4 Single Line Telephone User Guide

To place a call:

Lift handset + hear dial tone + dial number

To answer a call:

Lift handset when telephone rings

Message Waiting Lamp (Optional)

Lights when you have messages waiting (if your phone system can send them). Also flashes when your ST4 rings.

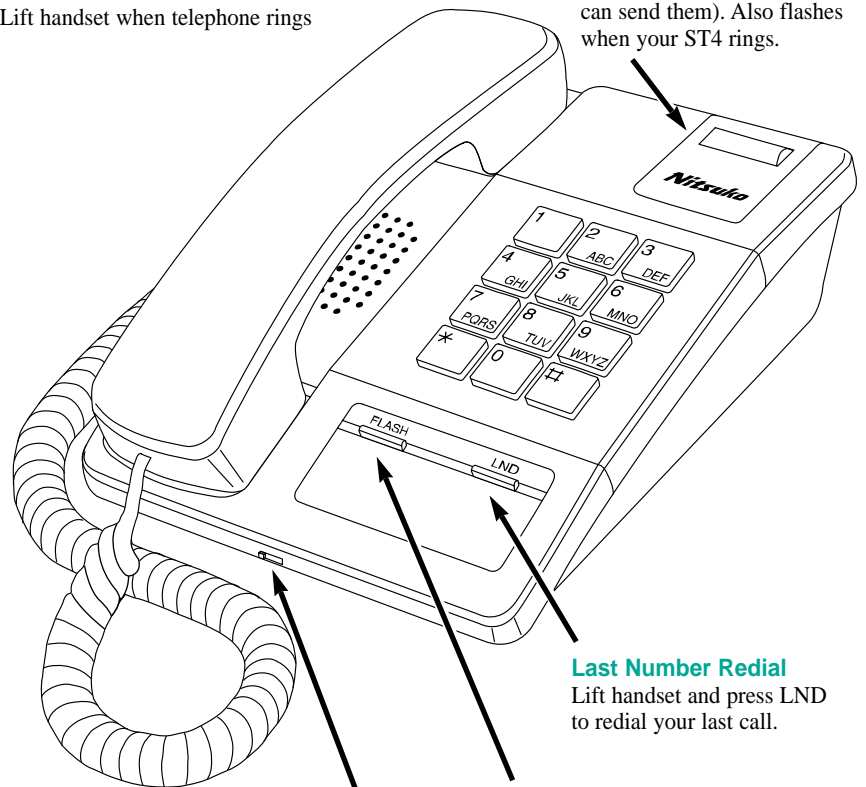

Last Number Redial

Lift handset and press LND to redial your last call.

Dial Mode Switch

[On bottom of phone.]

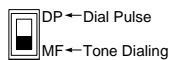

When placing a call in DP mode, you can dial * to change to Tone Dialing.

Flash

While on a call, press Flash for outside line or PBX features.

Volume Control

Use the three-position volume control to set the loudness of ringing.

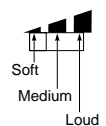

← Wall Mounting Instructions on back.

Installing the Wall Mount Kit

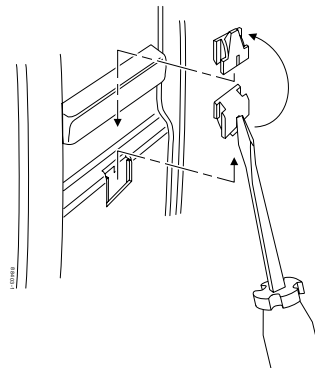

To install the handset hanger:

1. Use a small flat-blade screwdriver to push the hanger out of the phone.
2. Invert the hanger and push it back into the phone.

To wall-mount the phone:

1. Using the two screws provided (or other suitable fasteners), attach the wall-mount bracket to the wall.
2. Push the phone onto the mounting tabs and slide down until it clicks in place.

To store the handset without hanging up:

1. Hang the handset on the handset holder.

To remove the phone from the wall:

1. Push in the two retaining tabs on the bottom of the phone.
2. Slide the phone up off of the wall-mount bracket.

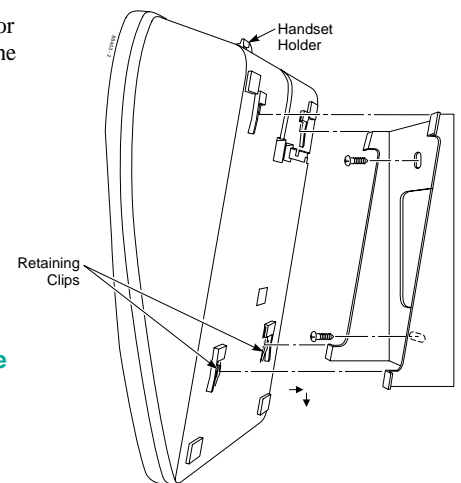

Federal Communications Commission (FCC) Note

1. Your ST4 complies with Part 68 of the FCC rules. The label located on the bottom of the phone contains the FCC registration number and Ringer Equivalence Number (REN) for this equipment. This information must be provided to the telephone company if requested.
2. The ST4 is designed to connect to the telephone line by means of standard 625 type modular jacks.
3. Your ST4 incorporates FCC compliant telephone cords, plugs and jacks and is designed to be connected to the telephone network using a compatible modular jack which is FCC Part 68 compliant.
4. The REN of this equipment is to be used to determine the quantity of devices which may be connected to a telephone line. Exceeding the maximum allowed REN of the telephone line may result in telephones not ringing in response to an incoming call. In most areas, but not all, the sum of the RENs must not exceed 5.0. To determine the maximum allowed in your specific area, contact your local telephone company.
5. If it is determined that this equipment causes harm to the telephone network, the telephone company will notify you in advance that temporary discontinuance of the service is required. But if advance notice is not practical, the telephone company will notify you as soon as possible. You may file a complaint with the FCC if you believe it is necessary.
6. The telephone company may make changes in its facilities, equipment, operations or procedures that could affect the operation of this equipment. If this happens the telephone company will provide advance notice in order for you to make the necessary modifications to maintain uninterrupted service.
7. If this equipment is not operating properly, you should immediately remove it from your telephone line, to prevent harm to the network, and contact Nitsuko America (or an authorized repair facility of Nitsuko America). You should not attempt to make any repairs on your own. For information, please contact:
Nitsuko America, Telecom Division
4 Forest Parkway
Shelton, CT 06484
Tel: 203-926-5400
8. This equipment cannot be used on coin service provided by the telephone company. Connection to party line service is subject to state tariffs. Contact the state public utility commission or corporation commission for information.
9. This equipment utilizes a telephone receiver that is **Hearing Aid Compatible**.

Industry Science Canada Note

Notice

The Canadian Department of Communications label identifies certified equipment. This certification means that the equipment meets certain telecommunications network protective, operational and safety requirements. The Department does not guarantee the equipment will operate to the user's satisfaction.

Before installing this equipment, users should ensure that it is permissible to be connected to the facilities of the local telecommunications company. The equipment must also be installed using an acceptable method of connection. In some cases, the company's inside wiring, associated with a single line individual service, may be extended by means of a certified connector assembly (telephone extension cord). The customer should be aware that compliance with the above conditions may not prevent degradation of service in some situations.

Repairs to certified equipment should be made by an authorized Canadian maintenance facility designated by the supplier. Any repairs or alterations made by the user to this equipment, or equipment malfunctions, may give the telecommunications company cause to request the user to disconnect the equipment.

Users should ensure, for their own protection, that the electrical ground connections of the power utility, telephone lines and internal metallic water pipe system, if present, are connected together. This precaution may be particularly important in rural areas.

CAUTION:

Users should not attempt to make such connections themselves, but should contact the appropriate electric inspection authority, or electrician, as appropriate.

Load Number

The Load Number (LN) assigned to each terminal device denotes the percentage of the total load to be connected to a telephone loop, which is used by the device to prevent overloading. The termination on a loop may consist of any combination of devices subject only to the requirement that the total of the Load Numbers of all the devices does *not exceed 100*.