

V-CTSQPK INSTALLATION INSTRUCTIONS

INTRODUCTION

The interior speaker, the V-CTSQPK, is capable of reproducing paging as well as back ground music. The volume may be adjusted by connecting various combinations on the input screw terminals. The enclosure is made of steel with a durable powder coated finish. The color of the enclosure can easily be changed to match any décor. The unit contains an 8" full range speakers.

DIMENSION/ WEIGHT

11.5" L x 11.5" W x 3.0" D
(29.2cm L x 29.2cm W x 7.62cm D)
2.6 lbs. (1.18kg)

INSTALLATION

- See Figure 1 To Set Volume Level
- See Figure 2 For Ceiling Mounting
- See Figure 3,4 For Wall Mounting

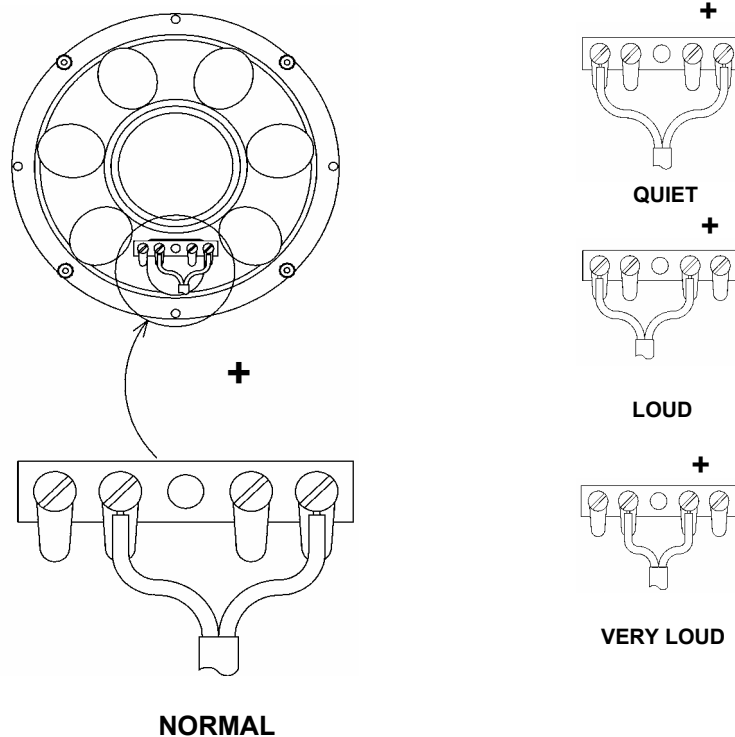

Figure 1

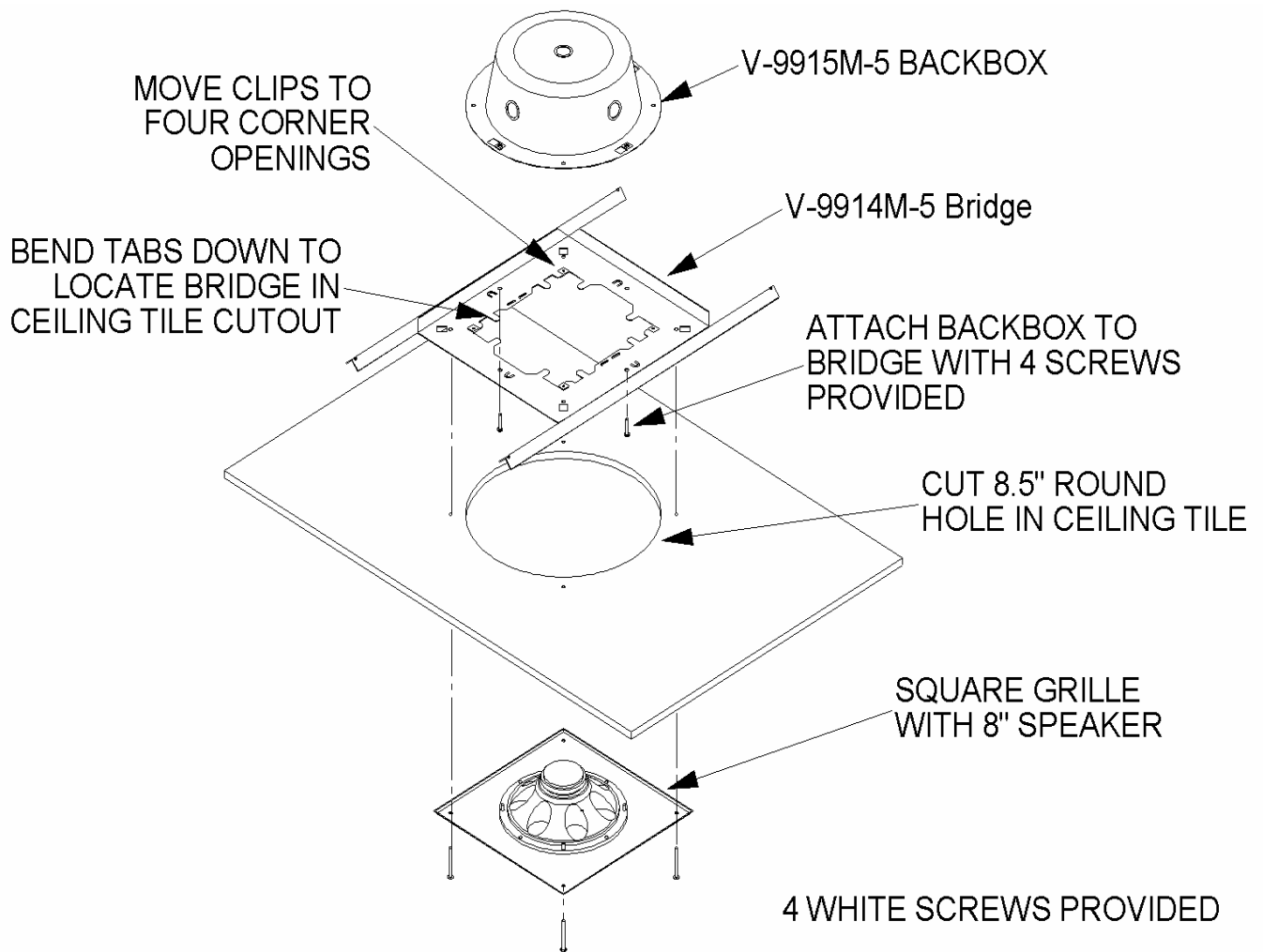

Figure 2: CEILING INSTALLATION INSTRUCTIONS

FIGURE 3: SURFACE MOUNT INSTALLATION INSTRUCTIONS

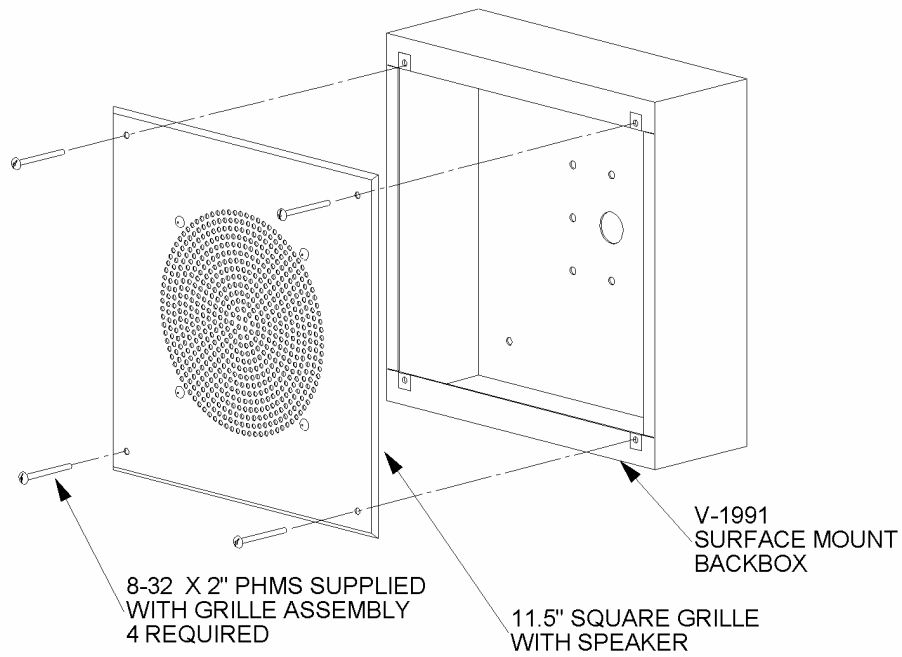

FIGURE 4A,B: FLUSH MOUNT INSTALLATION INSTRUCTIONS

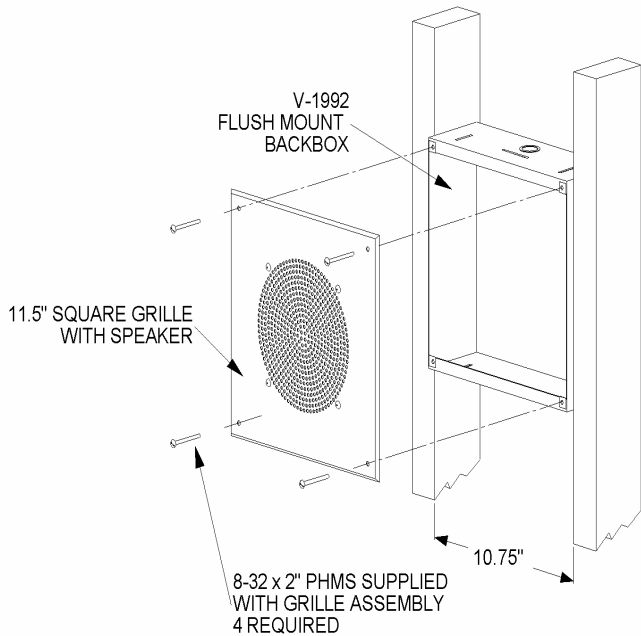

FIGURE 4A

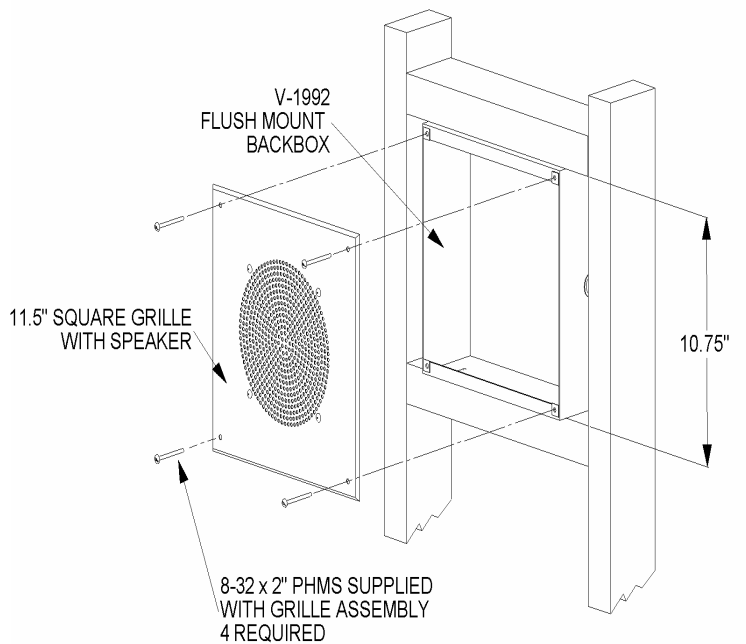

FIGURE 4B

ROUGH DIMENSIONS

TECHNICAL ASSISTANCE

Assistance in troubleshooting is available from the factory. When calling, you should have a VOM, a telephone test set and call from the job site. Call (540) 563-2000 and press 1 for Technical Support or visit our website at <http://www.valcom.com>.

Valcom equipment is not field repairable. Valcom, Inc. maintains service facilities in Roanoke, VA. Should repairs be necessary, attach a tag to the unit clearly stating company name, address, phone number, contact person and the nature of the problem. Send the unit to:

**Valcom, Inc.
Repair and Return Dept.
5614 Hollins Road
ROANOKE, VA 24019**

VALCOM LIMITED WARRANTY

Valcom, Inc. warrants its products to be free from defects in materials and workmanship under conditions of normal use and service for a period of one year from the date of shipment. The obligation under this warranty shall be limited to the replacement, repair or refund of any such defective device within the warranty period, provided that:

1. inspection by Valcom, Inc. indicates the validity of the claim;
2. the defect is not the result of damage, misuse or negligence after the original shipment;
3. the product has not been altered in any way or repaired by others and that factory sealed units are unopened (a service charge plus parts and labor will be applied to units defaced or physically damaged);
4. freight charges for the return of products to Valcom are prepaid;
5. all units 'out of warranty' are subject to a service charge. The service charge will cover minor repairs (major repairs will be subject to addition charges for parts and labor).

This warranty is in lieu of and excludes all other warranties, expressed or implied, and in no event shall Valcom, Inc. be liable for any anticipated profits, consequential damages, loss of time or other losses incurred by the buyer in connection with the purchase, operation or use of the product. This warranty specifically excludes damage incurred in shipment. In the event a product is received in damaged condition, the carrier should be notified immediately. Claims for such damage should be filed with the carrier involved in accordance with the F.O.B. point.

Headquarters:
Valcom, Inc.
5614 Hollins Road
Roanoke, VA 24019-5056
Phone: (540) 563-2000
FAX: (540) 362-9800

In Canada
CMX Corporation
35 Van Kirk Drive #11 an
Brampton, Ontario L7A 1A5
Phone: (905) 456-1072
FAX: (905) 456-2269