

Panasonic[®]

Video Intercom System
Door Station

Installation and Operation Guide

Model No. **VL-GC002A**

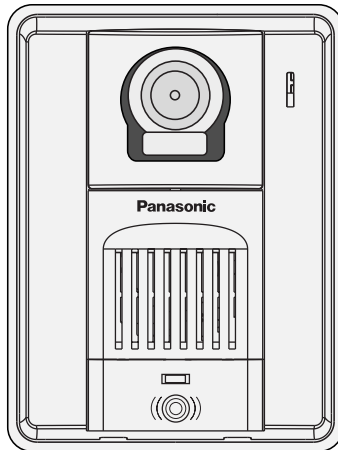

Thank you for purchasing a Panasonic Door Station.

Please read this Installation and Operation Guide before using the unit and save for future reference.

Important Information

| | |
|-------------------------------------|---|
| FCC and Other Information | 2 |
| Important safety instructions | 3 |
| Additional safety information | 4 |
| For best performance | 4 |

Introduction and Installation

| | |
|-----------------------------------|---|
| Included items | 5 |
| Location of controls | 6 |
| Before installation | 7 |
| Installing the door station | 8 |

Help

| | |
|----------------|----|
| Cleaning | 12 |
|----------------|----|

General Information

| | |
|---|----|
| Technical data about this product | 13 |
|---|----|

FCC and Other Information

This device complies with Part 15 of the FCC Rules. Operation is subject to the following two conditions:

- (1) This device may not cause harmful interference.
- (2) This device must accept any interference received, including interference that may cause undesired operation.

CAUTION:

Any changes or modifications not expressly approved by the party responsible for compliance could void the user's authority to operate this equipment.

NOTE:

This equipment has been tested and found to comply with the limits for a Class B digital device, pursuant to Part 15 of the FCC Rules. These limits are designed to provide reasonable protection against harmful interference in a residential installation. This equipment generates, uses, and can radiate radio frequency energy and, if not installed and used in accordance with the instructions, may cause harmful interference to radio communications.

However, there is no guarantee that interference will not occur in a particular installation.

If this equipment does cause harmful interference to radio or television reception, which can be determined by turning the equipment off and on, the user is encouraged to try to correct the interference by one or more of the following measures:

- Reorient or relocate the receiving antenna.
- Increase the separation between the equipment and receiver.
- Connect the equipment into an outlet on a circuit different from that to which the receiver is connected.
- Consult the dealer or an experienced radio/TV technician for help.

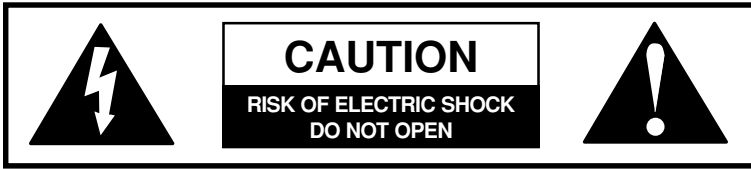

The lightning flash with arrow head within a triangle is intended to tell the user that parts inside the product are a risk of electric shock to persons.



The exclamation point within a triangle is intended to tell the user that important operating and servicing instructions are in the papers with the appliance.

Important safety instructions

- 1) Read these instructions.
All the safety and operating instructions should be read before the appliance is operated.
- 2) Keep these instructions.
The safety and operating instructions should be retained for future reference.
- 3) Heed all warnings.
All warnings on the appliance and in the operating instructions should be adhered to.
- 4) Follow all instructions.
All operating and use instructions should be followed.
- 5) Do not use this apparatus near water.
For example, near a bathtub, wash bowl, kitchen sink, or laundry tub, in a wet basement, or near a swimming pool, and the like.
- 6) Clean only with dry cloth.
Do not use liquid cleaners or aerosol cleaners. Use a dry cloth for cleaning.
- 7) Do not block any ventilation openings.
Install in accordance with the manufacturer's instructions.
Slots and Openings in the cabinet are provided for ventilation and to ensure reliable operation of the product and to protect it from overheating. The openings should never be blocked by placing the product on a bed, sofa, rug, or other similar surface.
- 8) Do not install near any heat sources such as radiators, heat registers, stoves, or other apparatus (including amplifiers) that produce heat.
This product should not be placed in a built-in installation such as a bookcase or rack unless proper ventilation is provided or the manufacturer's instructions have been adhered to.
- 9) Only use attachments / accessories specified by the manufacturer.
- 10) Refer all servicing to qualified service personnel. Servicing is required when the apparatus has been damaged in any way, such as power- supply cord or plug is damaged, liquid has been spilled or objects have fallen into the apparatus, the apparatus has been exposed to rain or moisture, does not operate normally, or has been dropped.

Additional safety information

1. Use only the power source marked on the unit. If you are not sure of the type of power supplied to your home, consult your dealer or local power company.
2. Use only the specified AC adaptor.
3. Do not tamper with the plug.
4. Make sure the plug is securely inserted.
5. Do not touch the plug with wet hands.
6. Do not place objects on the power cord. Install the unit where no one can step or trip on the cord.
7. To reduce the risk of electric shock, do not disassemble this unit. Take the unit to an authorized service center when service is required. Opening or removing covers may expose you to dangerous voltages or other risks. Incorrect reassembly can cause electric shock when the unit is subsequently used.
8. Unplug the monitor station from power outlets and refer servicing to an authorized service center when the following conditions occur:
 - A. If smoke rises, or an unaccustomed noise or smell is discharged from the unit.
 - B. If metal objects have been dropped inside the monitor station.
9. Do not put your ear(s) near the speaker, as loud sounds emitted from the speaker may cause hearing impairment.
10. Only a qualified technician is allowed to connect a power cable to the unit. Contact an authorized service center.
11. Do not make any wiring connections when the power supply is turned on.
12. Never install wiring during a lightning storm.
13. When existing chime wires are used, it is possible that they contain AC voltage. Electric shock or unit damage could result. Contact an authorized service center.
14. Be sure to install the unit as specified to endure the mass.
15. If the wiring is outdoors, use a protection tube or a surge protector.
16. If the wiring is underground, do not make any connections underground.
17. **WARNING** – Unplug this unit from power outlets if it emits smoke, an abnormal smell or makes unusual noise. These conditions can cause fire or electric shock. Confirm that smoke has stopped and contact an authorized service center.

For best performance

- If a power failure occurs, the unit will not function.

Included items

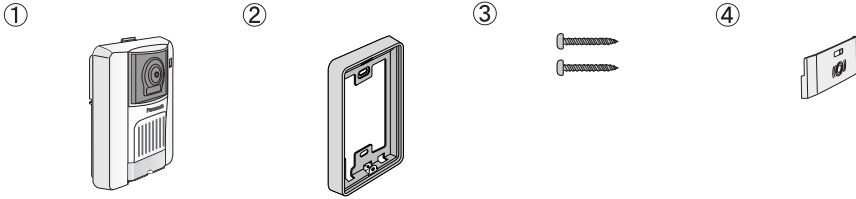

- The Mounting base comes preattached to the Door station.

| No. | Item | Quantity | Notes |
|-----|---------------|----------|---|
| ① | Door station | 1 | ----- |
| ② | Mounting base | 1 | ----- |
| ③ | Wood screws | 2 | 4 mm x 20 mm ($\frac{3}{16}$ " x $\frac{13}{16}$ ") |
| ④ | Button cover | 1 | ----- |

Location of controls

Front view

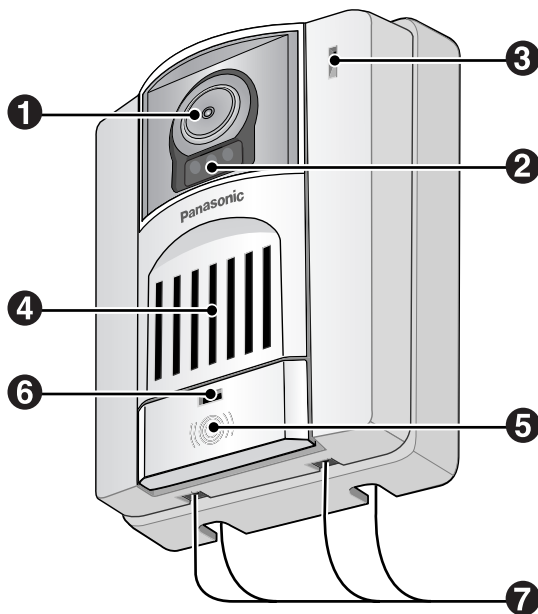

1 Camera

- When a visitor presses the Call Button, the camera will turn on and an image of the visitor will be shown on the display of the monitor station and sub monitor station.
- The camera angle can be adjusted when installing the door station (page 9).

2 Infrared light

3 Microphone

4 Speaker

5 Call Button*

- A visitor can press this button to call the monitor station and sub monitor station.

6 Position indicator (Green)

- The Position indicator is lighted with a green LED light while the power is on.

7 Water drain holes (4 places)

- These holes allow rainwater to drain away. Do not cover them.

* Be sure to attach the accessory button cover to the Call Button before using it. (The diagram shows the button cover installed.) (Page 11.)

Before installation

To avoid malfunction or communication disturbance, do not install the door station in the following locations:

- Places where vibration or any other kind of impact occurs.
 - Places where echoing is frequent.
 - Places where a high concentration of dust, hydrogen sulfide, phosphorus, ammonia, sulfur, carbon, acid, or noxious fumes occur.
 - Within 2 m (6'7") of a TV, microwave, personal computer, air conditioner or any other electrical device.
-

Note:

- Be sure to install the monitor station and sub monitor station more than 5 m (16'5") away from the door station.

Installing the door station

1 Loosen the mounting screw, and then remove the mounting base.

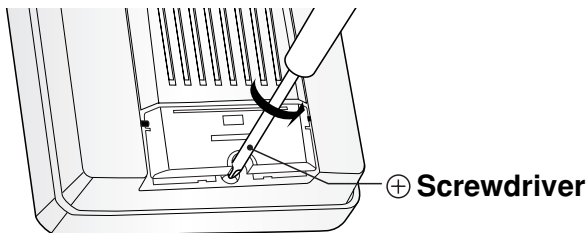

2 Install the mounting base to a wall using the attached wood screws.
(4 mm x 20 mm, $\frac{3}{16}$ " x $\frac{13}{16}$ ".)

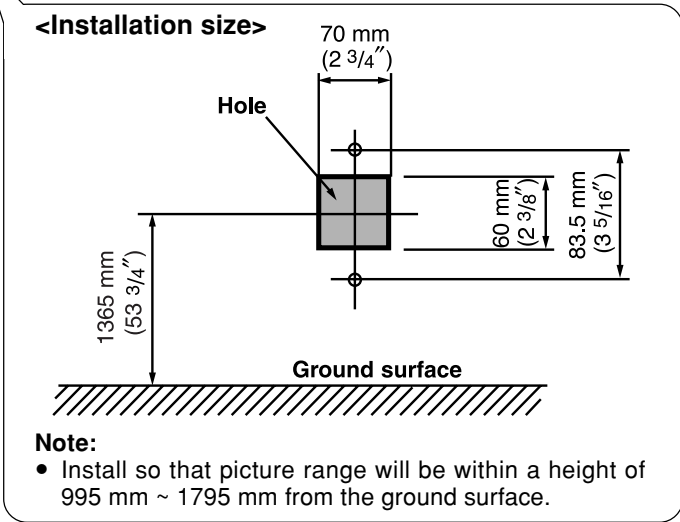
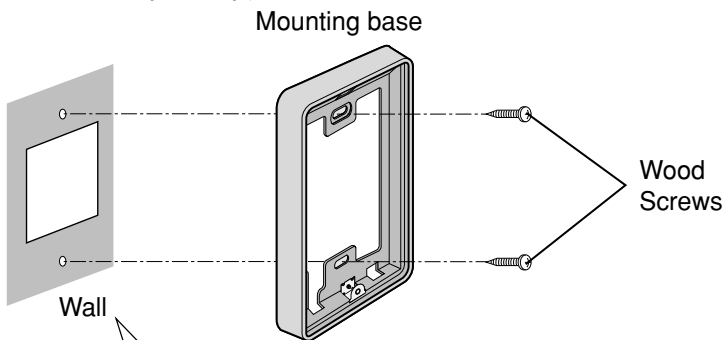

Important information:

On the bottom surface of the door station, there are holes to allow water to drain. Do not cover it up when installing.

3 Remove the adjustment cover, and then adjust the angle of the camera lens.

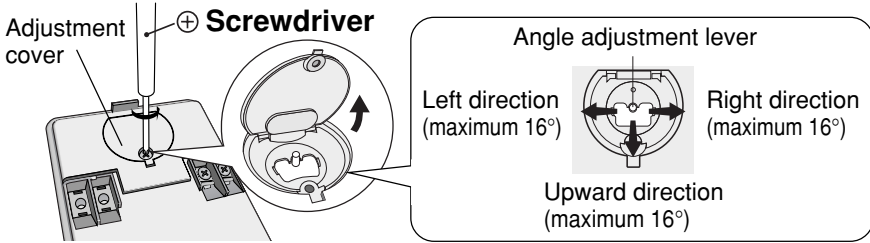

* Be sure to install the adjustment cover after adjusting the angle of the camera lens.

Standard installation height and filming range

Adjust the angle of the camera lens when carrying out installation.

● Vertical direction (facing the front)

● Horizontal direction (facing the front)

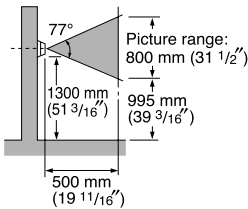

(16° upward)

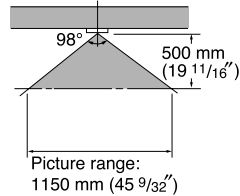
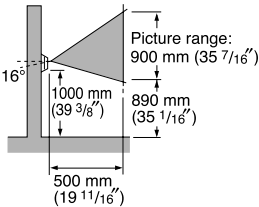

(16° to the right)

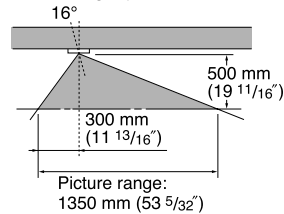

● The angle can also be adjusted 16° to the left.

Note:

- The measurements and angles are for reference purposes and may vary depending on the environment.
- If a strong light is against the door station, the visitor's face may not be distinguishable. Do not place the door station in the following locations.
 - Where most of the background is the sky.
 - Where the background is a white wall, and direct sunlight will reflect off it.
 - Where direct sunlight will shine on the door station.
 - Depending on where this unit is installed, surrounding noises will cause howling (beeping sound) to occur. Please avoid installing the unit in such a place.
- Make sure the back of the door station is not subject to water.

Wire type and distance

- Wire (between the monitor station and the door station):
Type: General cable CAT-3 24 AWG.
Distance: Maximum 100 m (about 328 feet).

Introduction and Installation

4 Attach the wire to the terminal.

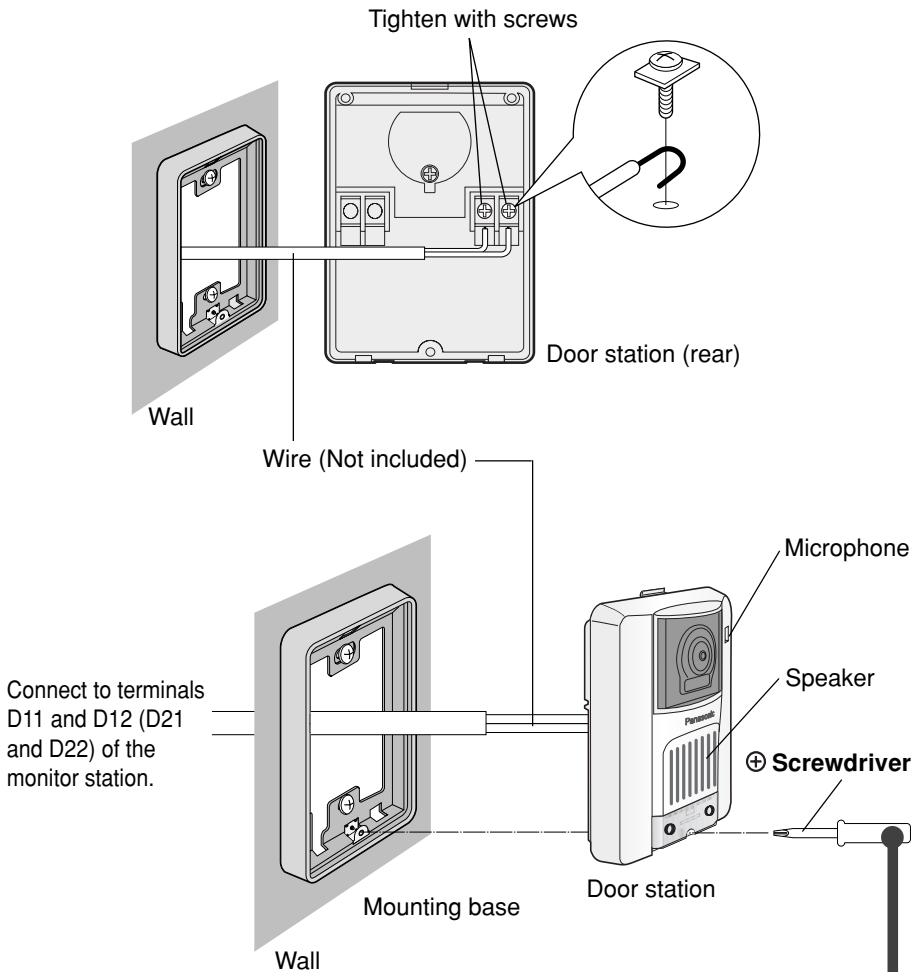

5 Secure the door station to the mounting base.

- Tighten the mounting screws.

6 Attach the button cover.

- Align the inside of the button cover base with the bottom of the call button, and then push the top of the button cover to fit it into place.

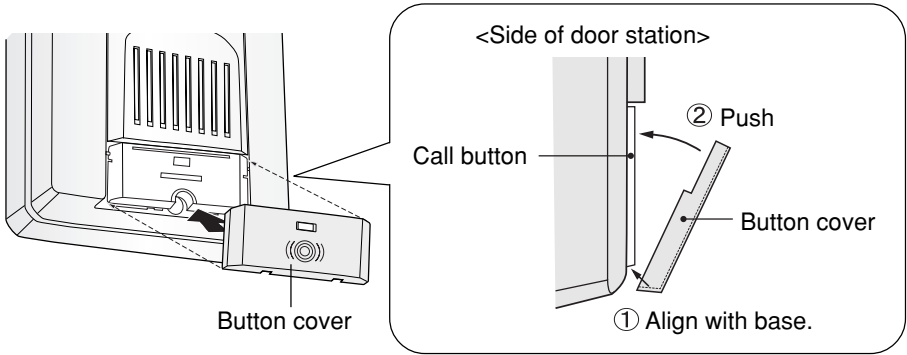

■ Removing the button cover

- Insert a flat-tipped screwdriver as far as it will go into the slot in the base of the button cover, and then turn the flat-tipped screwdriver to remove the button cover.

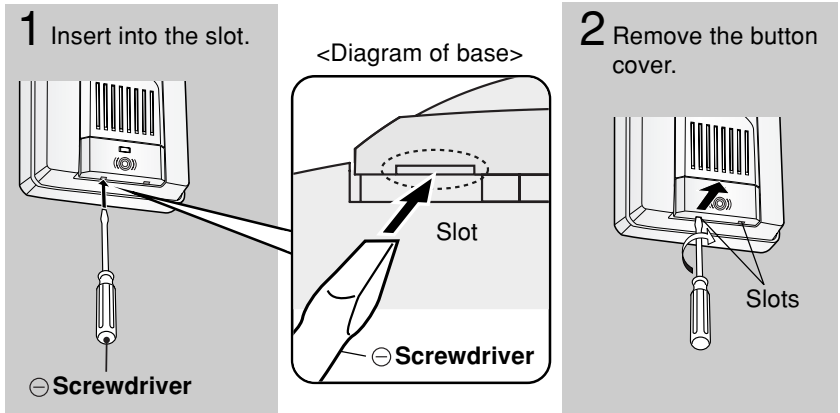

* Press against the button cover gently with a finger when removing it, to stop it from falling down.

Cleaning

Clean the unit with a soft, dry cloth when cleaning. For excessive dirt, wipe the unit with a slightly damp cloth.

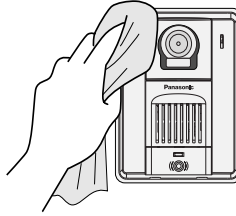

Important information:

- Do not use anything containing alcohol, polish powder, powder soap, benzene, thinner, wax, petroleum, or boiling water. Also do not spray with insecticide, glass cleaner, or hair spray. This could cause a change in color or quality.

Technical data about this product

| | |
|-------------------------------|---|
| Power supply *1: | Standby: Approximately 5 V DC (2 mA) At operation: Approximately 20 V DC (190 mA) |
| Dimensions: | Approximately height 130 mm x width 98 mm x depth 43 mm (5 1/8" x 3 7/8" x 1 3/4") |
| Mass (Weight): | Approximately 300 g (0.7 lb.) |
| Operating environment: | -10 °C to 50 °C (14 °F – 122 °F), Up to 90 % RH (Relative Humidity) non condensing |
| Installation method: | Wall mount (Wall mounting base included) |
| External material: | Flame retardant ABS resin (panel: acrylic resin) |

*1 Supplied from the monitor station.

Note:

- Design and specifications are subject to change without notice.
- The pictures and illustrations in these instructions may vary slightly from the actual product.

