

Roland®

LPK-1 / STK-1

Diagram Manual

\$
 \$
 \$ GR Guitar Controller Assembly \$
 \$ LPK-1 \$
 \$ STK-1 \$
 \$ Assembly Manual \$
 \$ OCT. 6 1984 \$
 \$

The Guitar Controller Assembly(LPK-1, STK-1) includes the Pickup and Pre-amplifier of the GR Guitar, Parts for fixing, Assembly Manual, etc. Using this Kit, you can convert an ordinary electric guitar to the GR Guitar Controller. The LPK-1 is for a Set-neck guitar and STK-1 for a Detachable guitar. Please note that this GR Guitar kit is designed specifically for professional guitar craftsmen, therefore, the manual does not include any information on basic modifying methods or tools.

	☆☆☆☆☆☆☆☆☆☆☆☆☆☆☆☆
Contents ☆	☆☆☆☆☆☆☆☆☆☆☆☆☆☆☆☆
[1] Parts List	☆ Please check your guitar ☆
	☆ before starting installation. ☆
[2] Notes	☆ If you find any dead point or ☆
	☆ note without enough sustain, ☆
[3] Modification(Set-neck Guitar LPK-1)	☆ please do not use it for GR ☆
A Disassembly	☆ Modification.(Refer to P.19 ☆
B Body Modification	☆ for the details.) ☆
C Assembly	☆☆☆☆☆☆☆☆☆☆☆☆☆☆☆☆
D Adjustment	☆☆☆☆☆☆☆☆☆☆☆☆☆☆☆☆
[4] Modificaion(Detachable Guitar STK-1)	
A Disassembly	
B Pick-Guard Modification	
C Body Modification	
D Pick-Guard Assembly	
E Assembly	
F Adjustment	

[1] Parts List

LPK

Divided Pickup #610	1		
Pre-Amp Board LPK	1		
Connector Holder	1		
Rear Cover	1		
Knob (Large)	4		
Knob (Small)	2		
Touch Plate (with vinyl wire)	2		
Bushing nut(Bushing M3)	2		
24P Connector 2324M-K	1		
Lock Shell 24 L1	1		
Jack SG-7713	1		
Binding screw M3 x 10	2		
Oval-headed screw 3 x 20mm	2		
Soft-tapping screw(Flat-headed)	2.	6 x 10mm	10
Flat-headed screw 3 x 10mm	4		
Washer M3	4		
Lock nut M3	4		
Volume Washer	6		
Volume Nut	6		
Spring 0. 6 x 3. 2 x 16mm	2		
Jack Washer	1		
Shielded wire	2		
Vinyl wire(Black)	1		
Templet LPK-T1	1		
LPK-T2	1		

STK

Divided Pickup #610	1	
Pre-Amp Board STK	1	
Back Panel STK	1	
Knob (Large)	3	
Knob (Small)	3	
Touch Plate(with vinyl wire)	2	
Pickup base	1	
24P Connector 2324M-K	1	
Lock Shell 24 L1	1	
Jack SG-7713	1	
Binding screw M3 x 10	2	
Oval-headed screw 3 x 20mm	2	
Soft-tapping screw(Flat-headed)	2. 6 x 10mm	9
Washer M3	4	
Lock nut M3	4	
Volume Washer	6	
Volume Nut	6	
Spring 0. 6 x 3. 2 x 16mm	2	
Shielded wire	1	
Vinyl wire(Black)	1	
Jack Washer	1	
Templet STK-T1	1	
STK-T2	1	
STK-T3	1	

[2] Notes

The Templet can be easily peeled and stuck to the guitar body. The holes to be bored and the hollow to be cut away or scraped are shown on it, and the normal holes positions before modification are also shown for you to refer to in sticking the templet to the guitar.

The measurement are all shown in metric system(mm).

$$1 \text{ mm} = 0.0394 \text{ in}$$

$$1 \text{ in} = 25.4 \text{ mm}$$

[3] Modification (Set-neck guitar LPK-1)

A Disassembly

Remove the strings and obstructive or unnecessary parts.

B Body Modification

1) Stick the Templet LPK-T1 onto the surface of the guitar body, then modify its surface according to the templet.

* If the guitar has an arched-top, the templet may not fit on the body so well, but what is essential here is that you can roughly see the hole positions.

* Before actually boring the two 6mm holes near the Bridge, place the Bridge Pickup #610 and the Hum-backing Pickup on the body to make sure that they will not collide with each other. If they happen to touch each other, slightly move the Hum-backing Pickup away from the Bridge. Also, make sure that the distance between the two holes is exactly 78mm and symmetrical to the center line.

* Use a boring machine and make the holes vertical to the body.

2) Stick the Templet LPK-T2 onto the back of the body and modify the surface according to the templet.

* Please do not cut the Ground wire of the Talepiece.

3) Scrape the wooden part of the back body around the Pot-shaft hole (about 18mm radius) leaving 5mm depth. Please do this job cautiously.

Fig 1-1

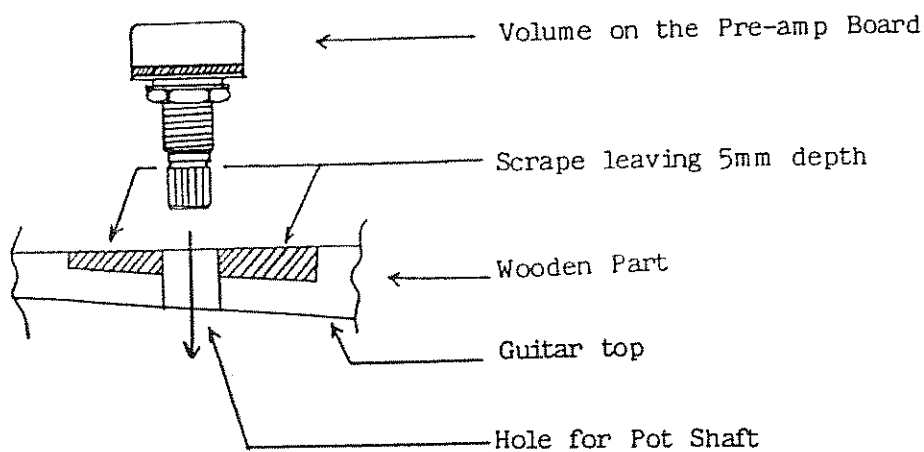

C Assembly

1) Bore 3. 2mm holes on the Escutcheon of the Ham-backing Pickup on the Bridge side to fix the Touchplate.

Fig 1-2

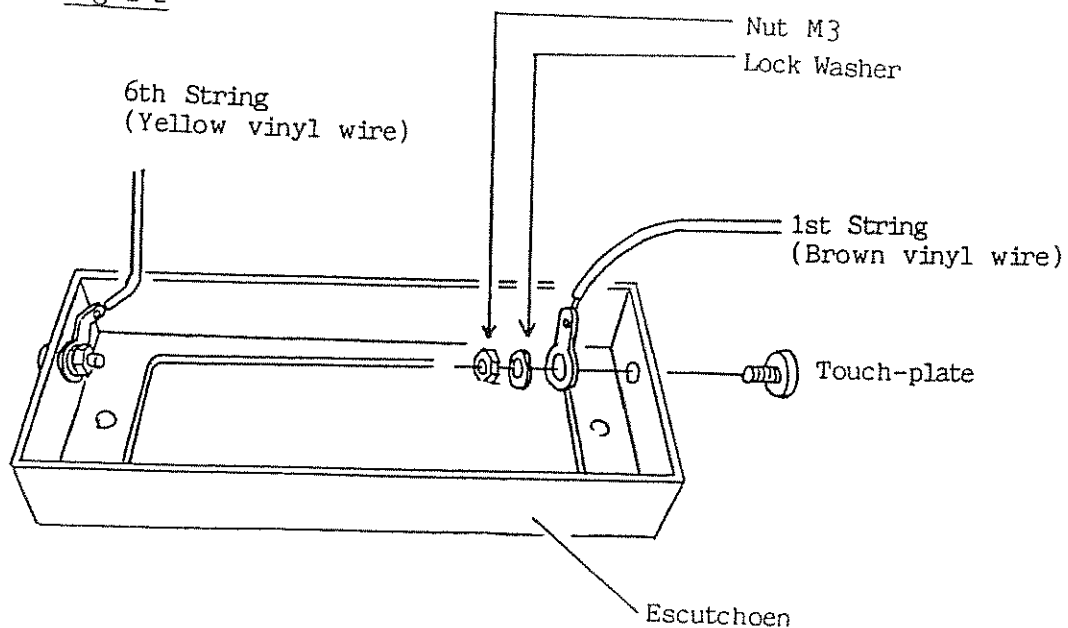

2) Strike the Bushing nut M3 into the 6mm holes on the body, then fix the Divided Pickup #610. The lead wire of the Pickup(Flexible PCB) should be passed through the holes and go to the back side of the body. (Fig 1-3)

Fig 1-3

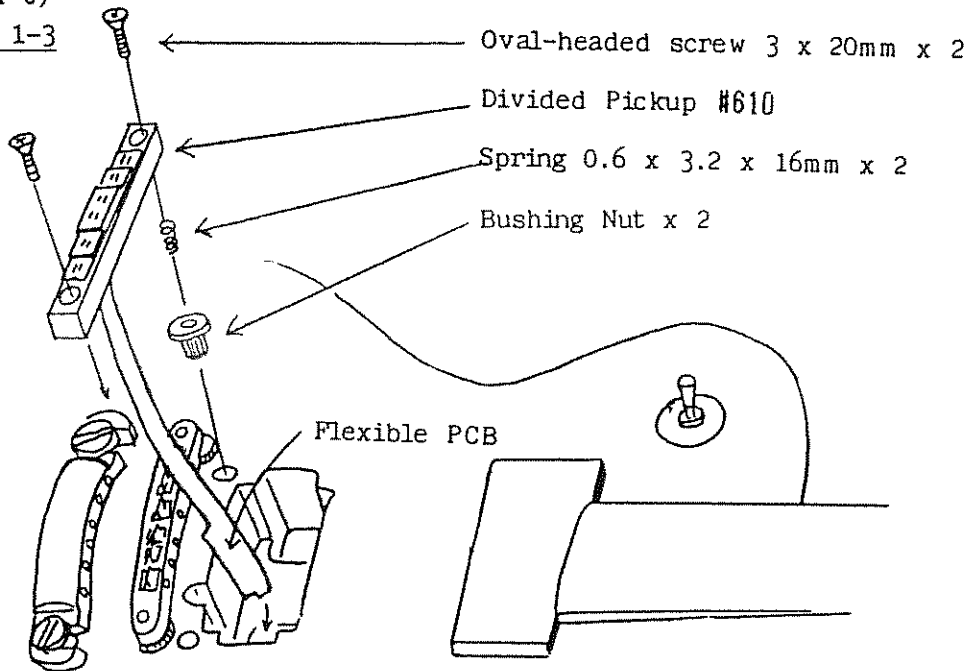

3) Distribute the wires as shown in the supplied diagram. Use the supplied shielded wire connecting to the Pickup Selector. After wiring, fix the Pickup to the body. (Refer to the Diagram.)
 4) Solder the lead wires to the Flexible PCB of the Pickup #610. (Fig 1-4)

Fig 1-4 (Fig 2-3)

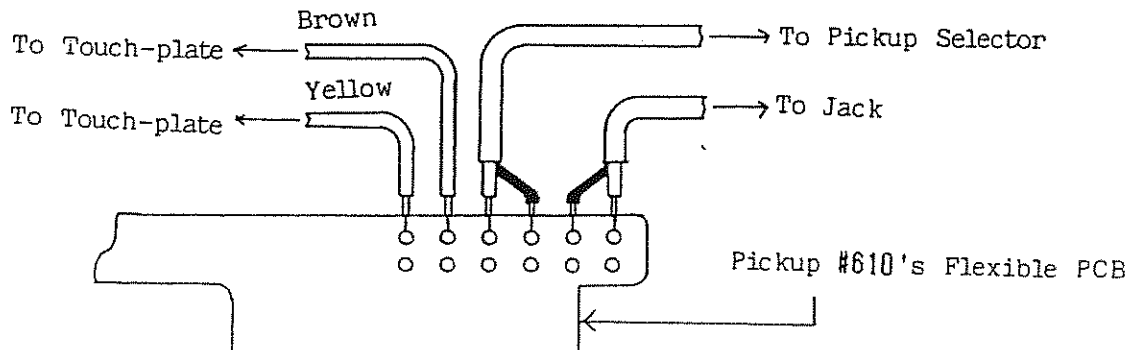

5) Fix the VR and SW on the Pre-amp Board to the body. (Fig 1-5)

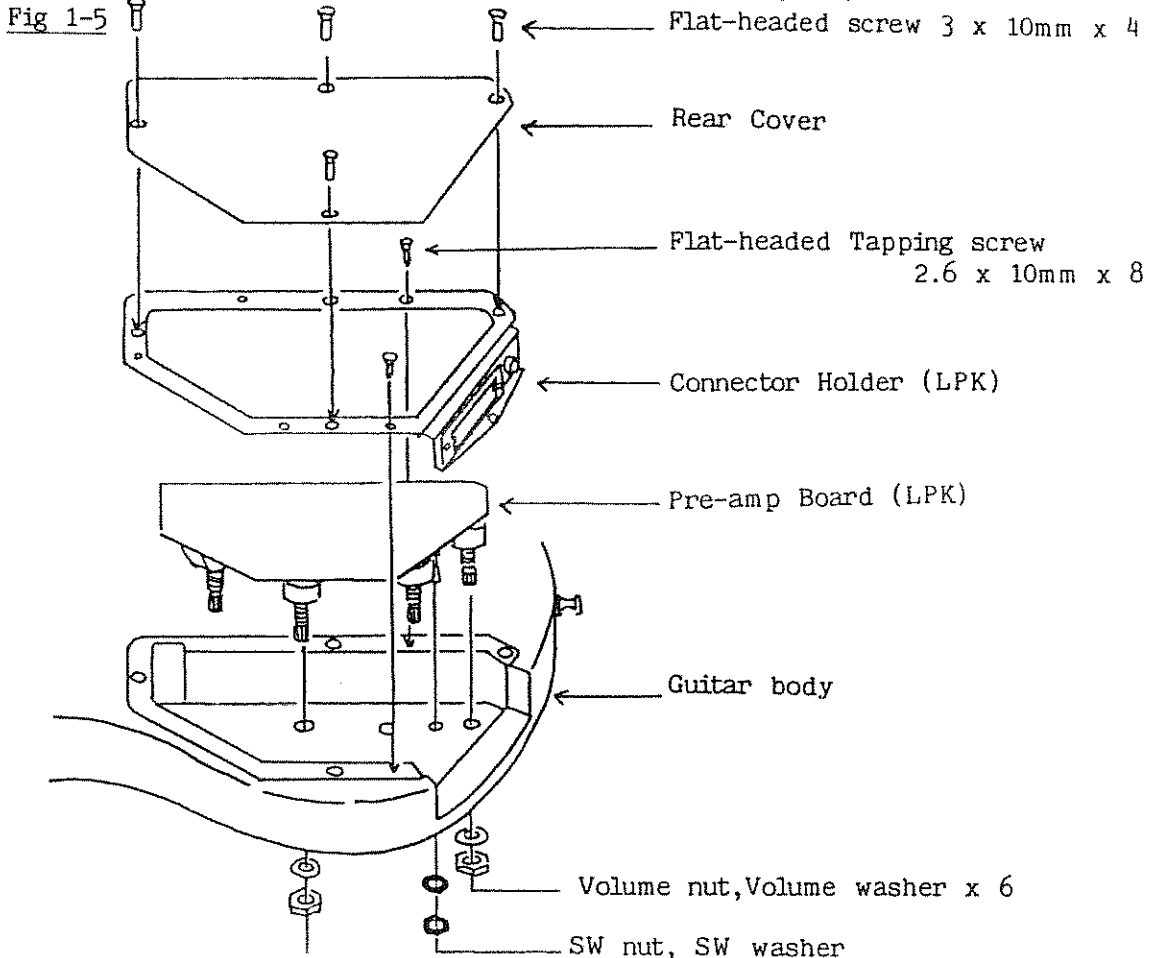

6) Set the board where the VR and SW jacks do not touch it. Then attach the board to the guitar body with the tapping screws.

Fig 1-6

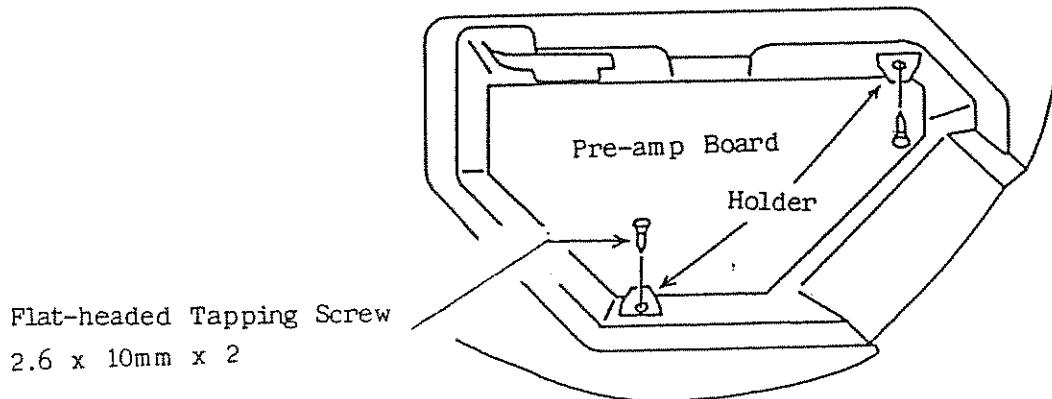

7) Fix the 24P Connector(2324M-K) and the Jack to the Connector Holder.

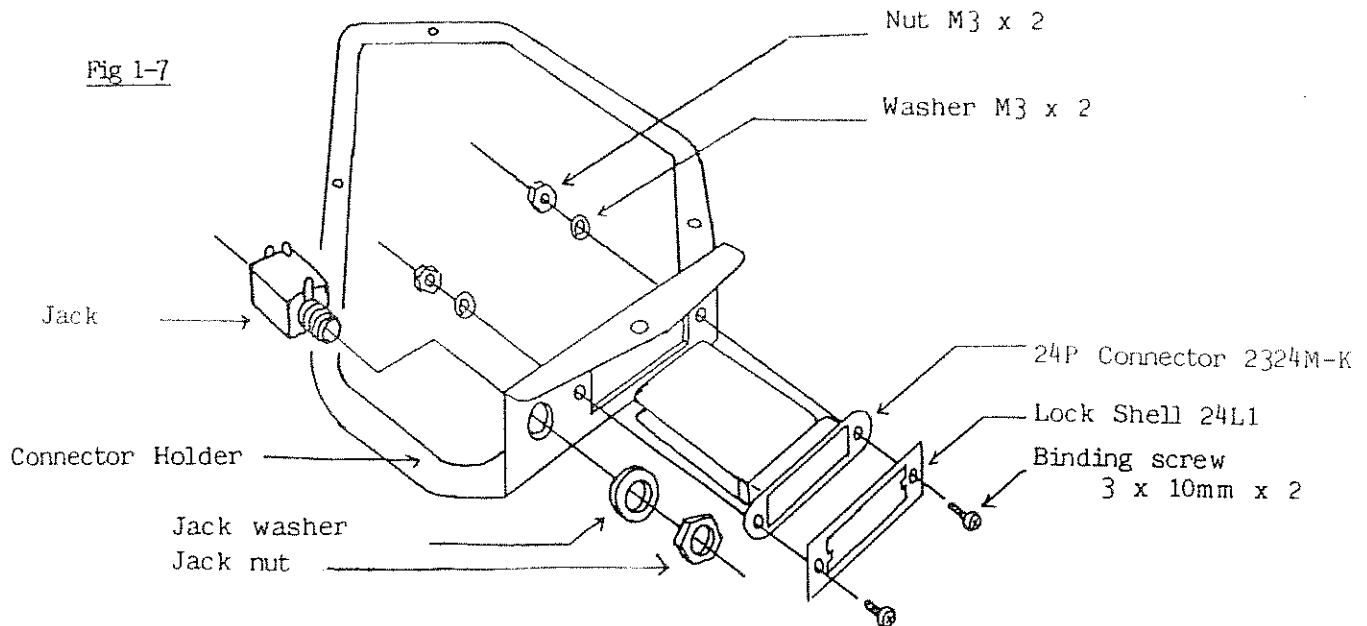

8) Solder the other end of the shielded wire attached to the Flexible PCB of the Pickup #610 and the Talepiece ground wire to the Jack of the Connector Holder. If the ground wire is too short, extend it using the supplied wire(black vinyl one).

Fig 1-8 (Fig 2-5)

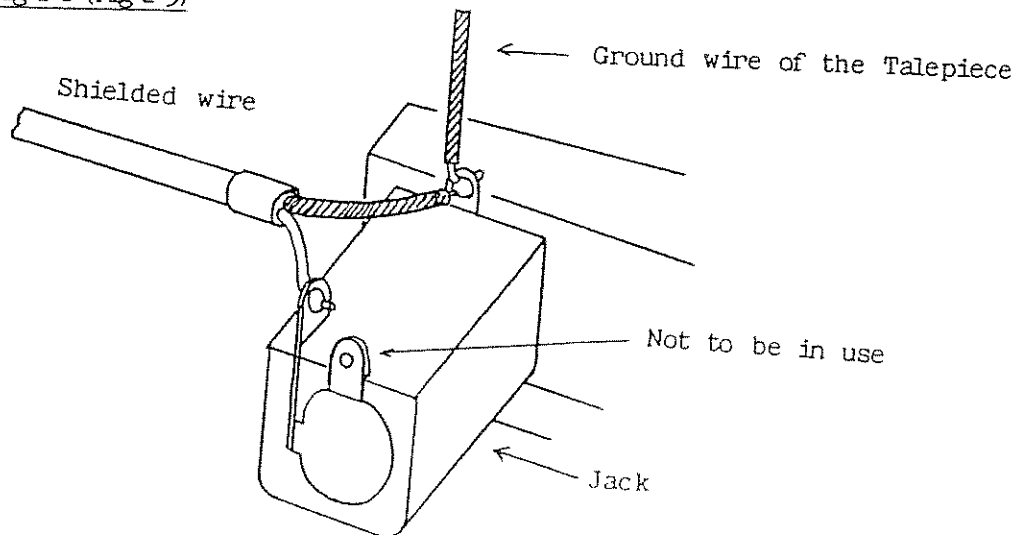

9) Fix the Connector Holder to the body by using the screws. (Fig 1-5)

10) Plug the Flexible PCB of the Pickup #610 and that of the 24P Connector on the Connector Holder into the socket on the Pre-amp Board.

D Adjustment

1) Set the strings.

2) Press the 20th fret of each string, then set the height of the Pickup #610 as shown below by changing the distance between the strings and the polepiece.

First String	0.5mm
Sixth String	0.7mm

3) Set up the GR-300 to the Guitar and see if there is any trouble as follows.

a) Does normal guitar signal come out?

b) Does Hexa distortion sound come out ?

c) Does VCO of each string work properly?

d) Are each CV, the Master Volume, Balance, Cutoff Frequency, Resonance and Touch-Vibrato working all right?

4) Adjust the divided signal of each string. First, set the GR-300 so as to produce only the VCO sound. Then turn all the Foot Switches off, and set the Cutoff Frequency to 10 and Resonance to zero. Adjust the Trimmer so that the all six strings give the same volumes when they are played at a sort of medium strength. If the second to fifth strings give such small levels that adjusting turns out difficult, scrape their bridges to lower them.

5) Fix the rear panel to the body with the screws. (Fig 1-5)

[4] Modification (Detachable Guitar STK-1)

A Disassembly

Remove the strings and obstructive or unnecessary parts.

B Pick-Guard Modification

Stick the Templet STK-T1 to the plastic board and cut it away to make a Pick-Guard.

C Body Modification

- 1) Stick the Templet STK-T2 to the body top and modify its surface.
- 2) Stick the Templet STK-T3 onto the rear body and modify its surface.

D Pick-Guard Assembly

- 1) Attach the Pickup, switches, Touchplate, and Pre-amp Board to the Pick-Guard you have just made. (Fig 2-1)

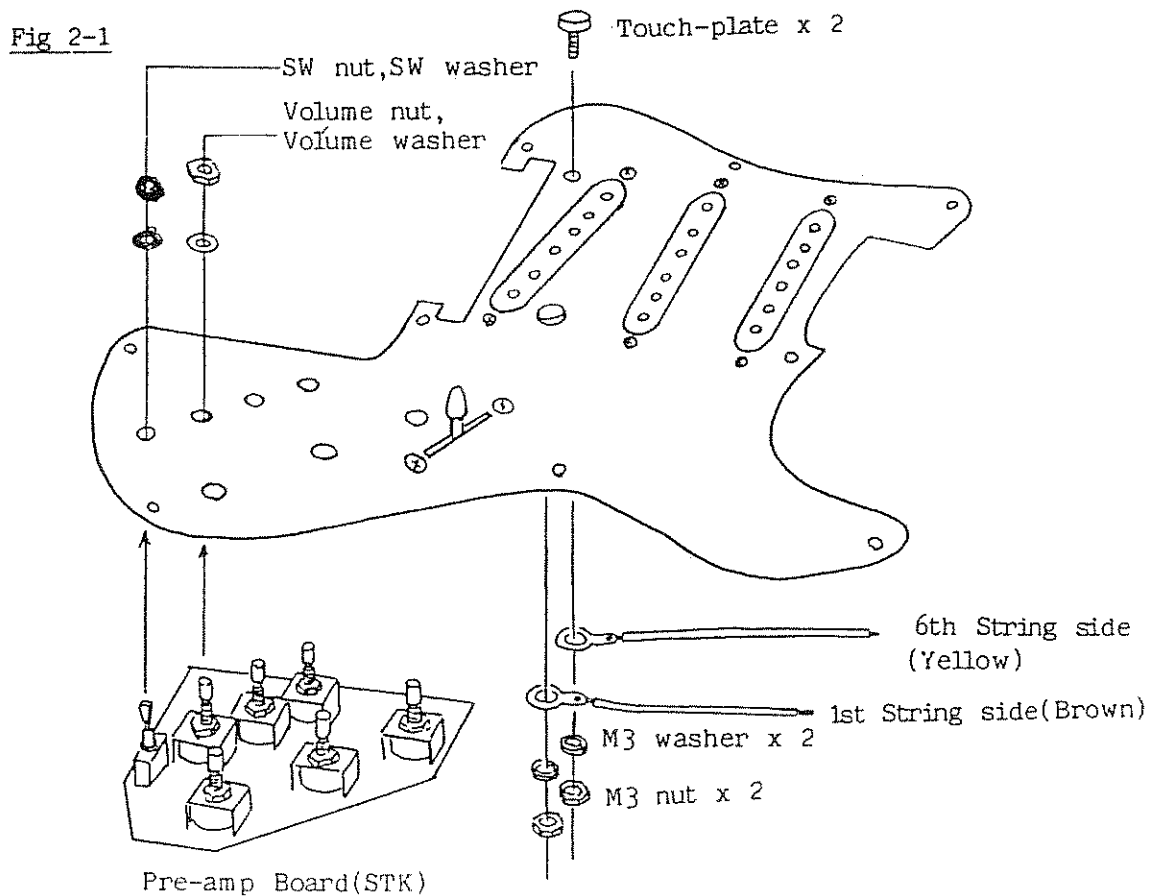

2) Distribute the wires in the normal guitar section. (Refer to the diagram.)

E Assembly

1) Fix the Divided Pickup Base to the body. (Fig 2-2)

Fig 2-2

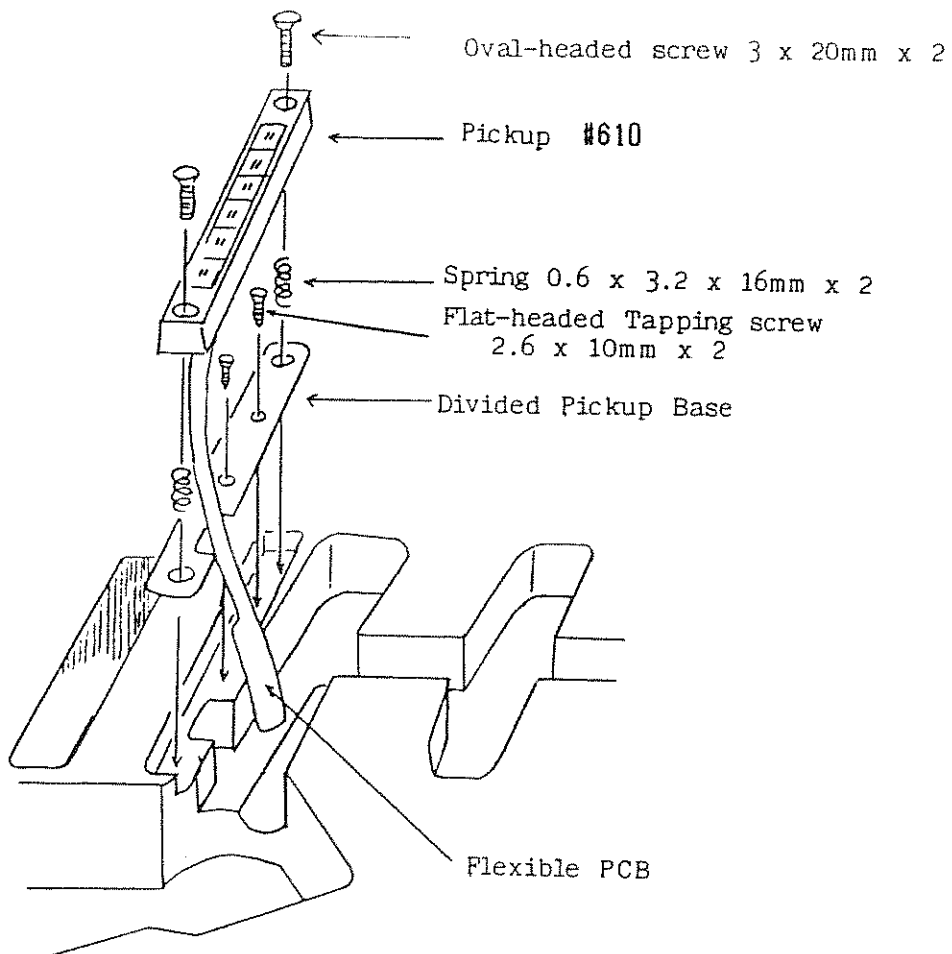

2) Solder the lead wires to the Flexible PCB of the Divided Pickup #610.
(Fig 2-3 on P 6)

3) Pass the Ground wire of the Talepiece and the shielded wires attached to the Flexible PCB of the Pickup #610 through the hole made on the guitar body.

4) Insert the Flexible PCB of the Pickup #610 to the Socket 1 of the Pre-amp Board attached to the Pick-Guard.

5) Fix the Pick-Guard to the body with the screws.

6) Fix the Divided Pickup #610 to the Pickup Base. (Fig 2-2 on P 11)

7) Attach the 24P Connector(2324M-K) and the Jack to the Back Panel.
(Fig 2-4)

Fig 2-4

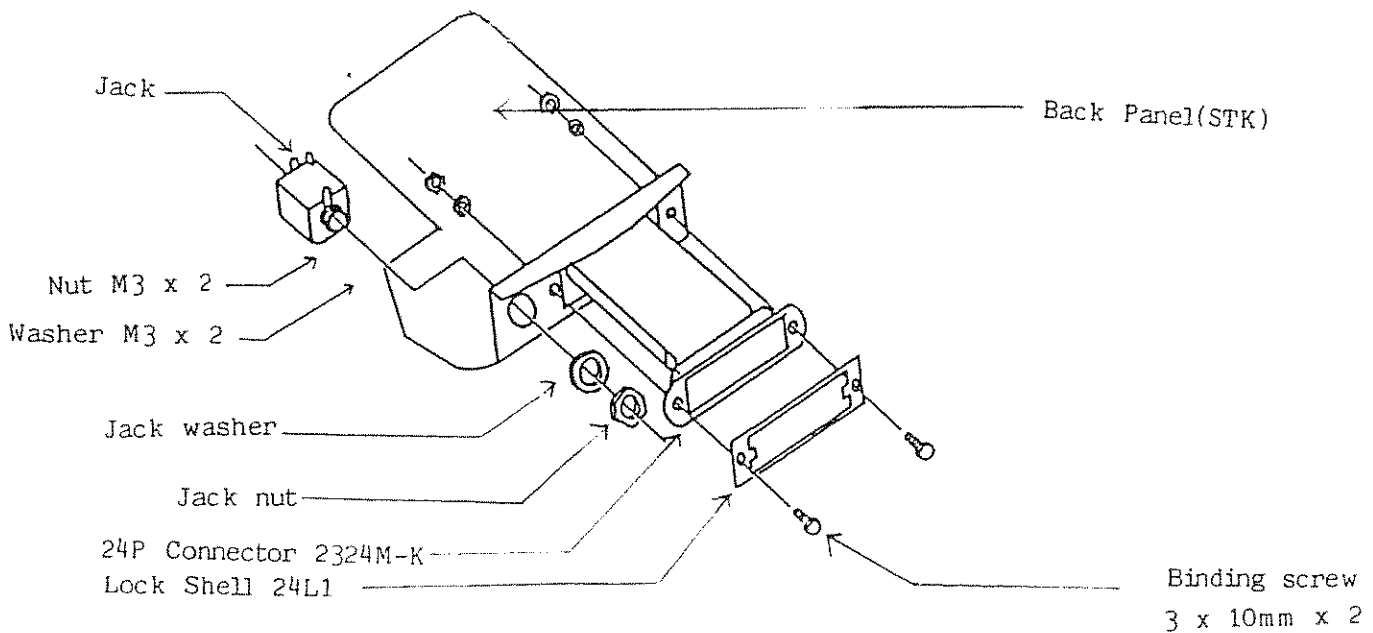

8) Solder the Ground wire and the shielded wires to the Jack attached to the Back Panel. (Fig 2-5 on P 8)

9) Insert the Flexible PCB attached to the Connector on the Back Panel into the Sockets 2 and 3 which are visible from the holes on the back body. Then fix the Back Panel to the body with the screws. Here, be sure that the six small holes on the Back Panel properly fit on the six holes on the body. (2-6)

Fig 2-6

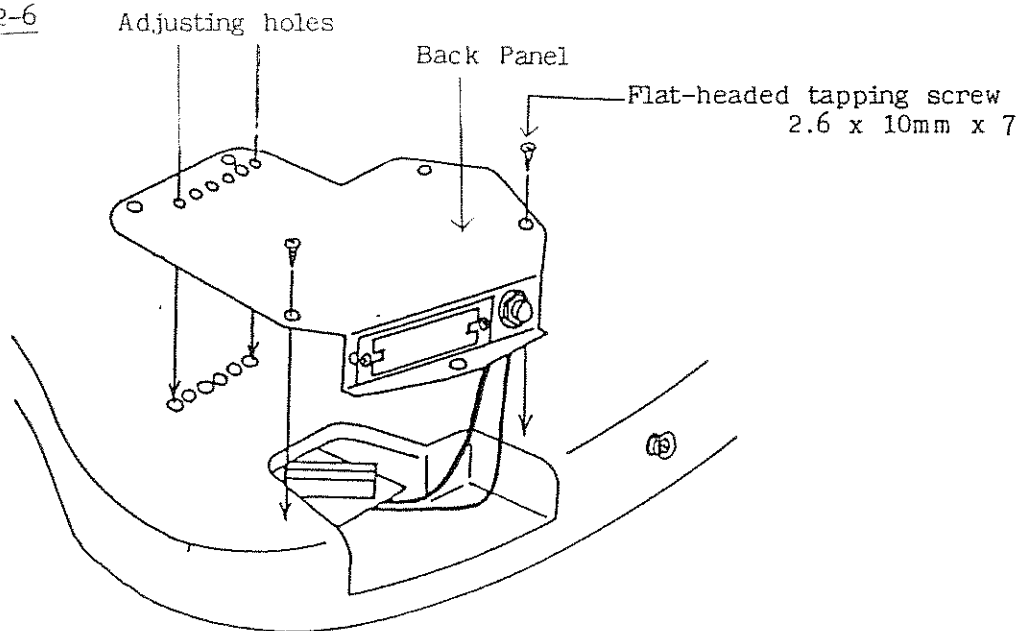

F Adjustment

2) Press the 20th fret of each string, then set the height of the Pickup #610 as shown below by changing the distance between the strings and the polepiece.

First String	0.5mm
Sixth String	0.7mm

3) Set up the GR-300 to the Guitar and see if there is any trouble as follows.

a) Does normal guitar signal come out?

b) Does VCO of each string work properly?

c) Are each CV, the Master Volume, Balance, Cutoff Frequency, Resonance and Touch-Vibrato working all right?

* Please note that Hexa distortion of this STK-1 will not function.

4) Adjust the divided signal of each string. First, set the GR-300 so as to produce only the VCO sound. Then turn all the Foot Switches off, and set the Cutoff Frequency to 10 and Resonance to zero. Adjust the trimmer so that the all six strings give the same volumes when they are played at a sort of midium strength. The Trimmer can be rotated through the holes on the Back Panel with a small slot-headed screwdriver. If the second to fifth strings give such small levels that adjusting turns out difficult, lower the bridges of second to fifth strings.

[5] Diagram(LPK-1, STK-1)

A. LPK-1

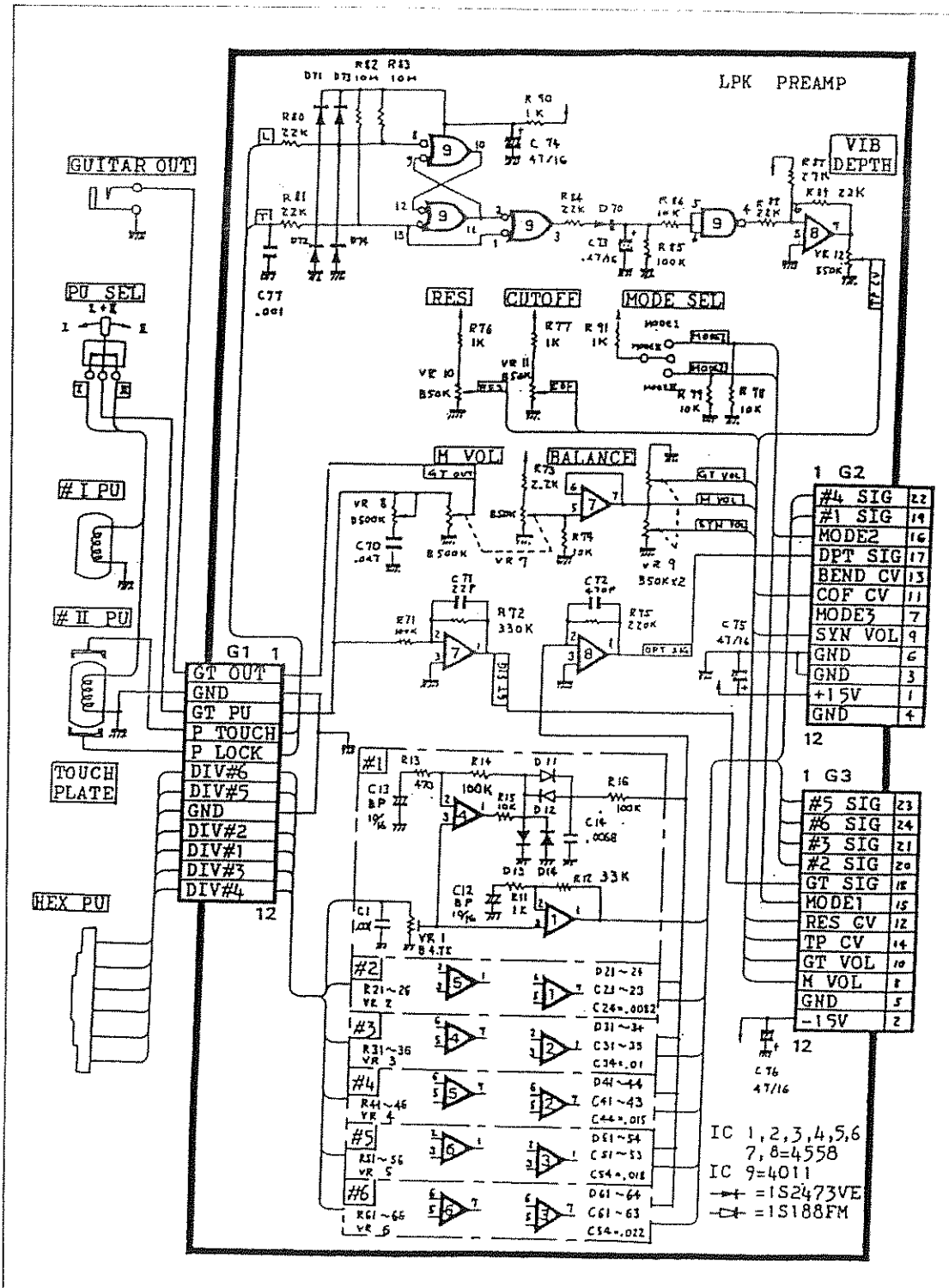

B. STK-1

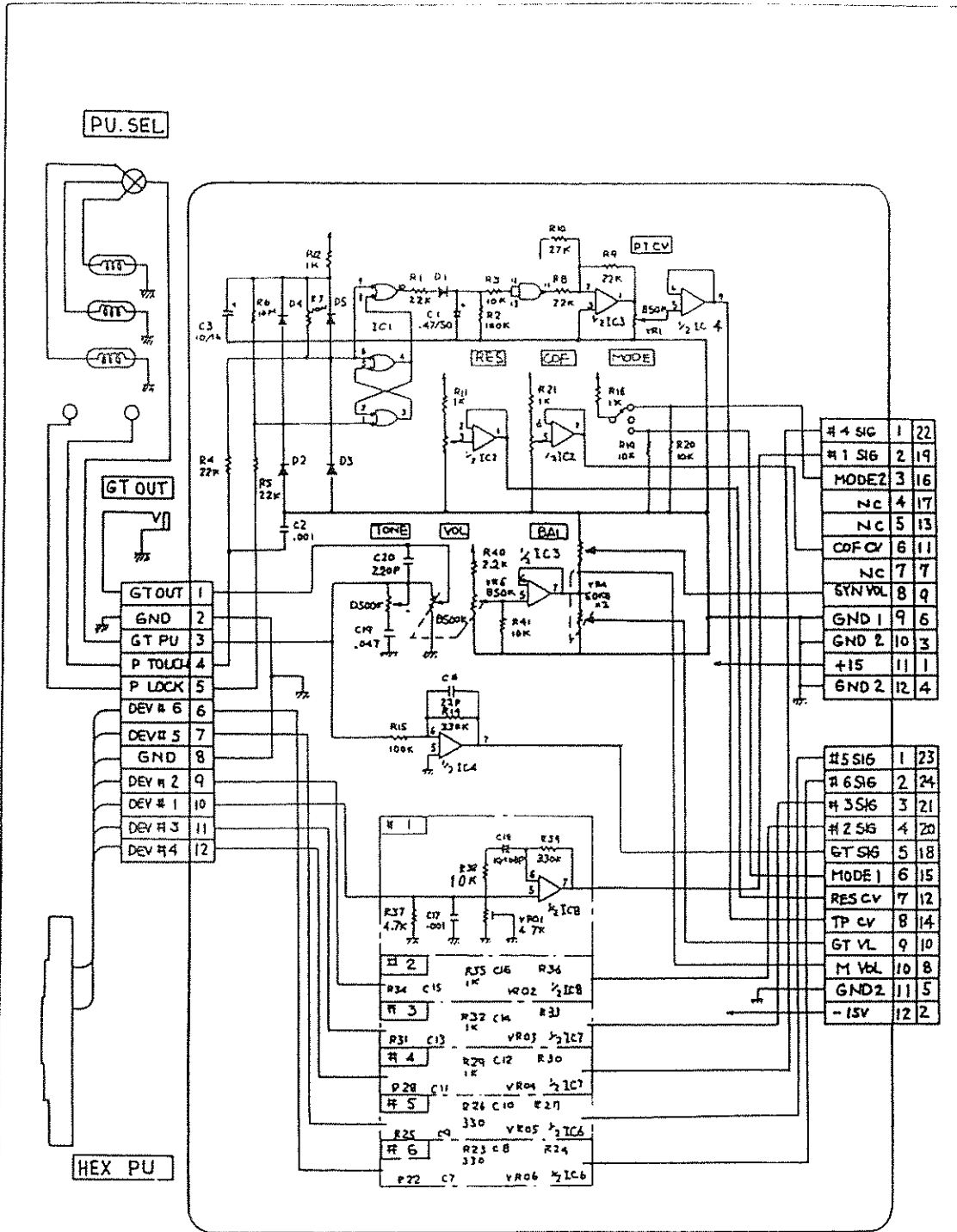

D1 ~ D5 ; 1S2473
 IC1 ; TC4011
 IC2 ~ IC8 ; MS218L

< How to find the dead point and octave jump >

★ Dead Point

1 Set up a distortion unit with the guitar, then an amplifier.

* You may use the distortion built in the amplifier.

2 Feedback will obstruct this test, so adjust the distortion level and volume.

3 Play each fret of all the strings one by one. Please do not touch the next fret until each note completes its envelope shape.

Please make sure that the other string is not resonating. Also, hand vibrato technique should be refrained.

Dead Point is where a sound fades out quickly without sustain.

★ Octave Jump Point

1 Set up a distortion unit with the guitar, then an amplifier. Adjust the controls of the distortion unit to obtain the strong feedback effect.

2 Play each fret of all the strings one by one. Please do not touch the next fret until the currently played note completes its envelope shape.

If the pitch of one note does not change during sustain, the guitar is proved to have no problem. Octave Jump is one octave pitch raise during a sustained note.

☆☆☆☆☆☆☆☆☆☆☆☆☆☆☆☆☆☆☆☆☆☆☆☆☆☆☆☆☆☆☆☆
☆
☆ The STK-1 dose not feature ☆
☆ the Hexa Distortion function. ☆
☆ Therefore, even if the GR-300 ☆
☆ is used and The Mode Switch ☆
☆ is set to the I or II position, ☆
☆ Hexa Distortion sound cannot ☆
☆ be obtained. ☆
☆
☆☆☆☆☆☆☆☆☆☆☆☆☆☆☆☆☆☆☆☆☆☆☆☆☆☆☆☆☆☆☆☆

 Roland®

10180

UPC 10180



10180

 Roland®