

Speaker Layout

Figure 1

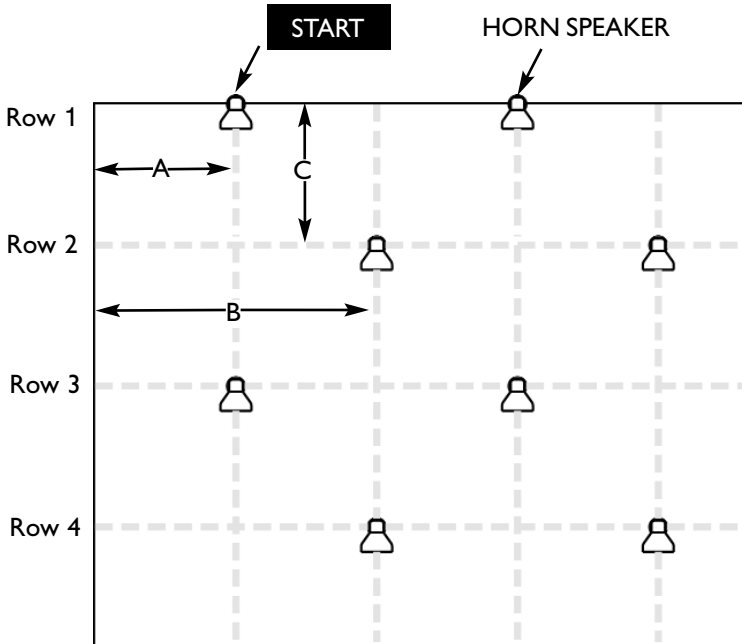

The layout of the speakers should be planned prior to installation. Desired mounting height, barring obstructions, is 15 to 20 feet, with the speakers angled downward toward the listening area and facing in the same direction.

Layout starts in one corner of the area. The first speaker in Row 1 should be positioned 45 feet from the corner. The next speaker in Row 1 should be 90 feet from the first speaker (see Figure 1). Each additional speaker in the row should use this same spacing.

Row 2 starts 55 feet from Row 1 and, like Row 1, each speaker in Row 2 should be 90 feet apart.

Row 3 starts 55 feet from Row 2. Continue this pattern of alternating rows until the area is covered.

For areas that include high shelving or corridors, speakers should be installed so that they project down the aisles between the shelves or down through the corridors.

The spacing of the speakers can be adjusted so that the speakers are evenly spaced in a row.

NOTE: Each environment is unique. This layout plan is general in nature and may not be applicable for every installation.

Figure 2

	PLACEMENT			Volume Setting
	A	B	C	
Very High Noise (85dB-95dB)	45 ft.	90 ft.	55 ft.	Full Clockwise

Speaker Installation

STEP 1 - For easier installation, remove the flange (base) from the speaker by unscrewing the wing nut while at the same time pressing inwardly on the wing nut. Place the flange flush with the mounting surface and mark the location of the three holes with either a marker or chisel. It is important that the three holes be exactly aligned with the flange, otherwise you might stress the base or make the connection unsteady. Drill the necessary holes and screw the flange to the surface (see Figure 3). (Use appropriate hardware for your specific mounting surface.)

NOTE: The speaker may also be strap-mounted using standard 1/2-inch industrial strapping.

STEP 2 - After mounting the flange, reattach the speaker to the flange and aim the speaker for the desired coverage. A 45° downward angle is recommended, but this may vary depending upon speaker layout and floor plan.

STEP 3 - Remove the plastic cover to make the electrical connection and set the volume control (see Figure 4). The suggested amplifier connections are:

Amplifier Outputs	Speaker Connections
70V	Terminal 1
COM	Terminal 2

NOTE: The speaker will also work perfectly well with these connections reversed. However, it is important to be consistent in the wiring of the speakers in the system.

STEP 4 - Adjust the volume control to the desired setting. See Figure 2 for the suggested initial settings based on the ambient noise level of the environment. Place the protective cover back over the exposed area.

NOTE: The two furthestmost clockwise settings on the volume control will produce the same volume.

Figure 3

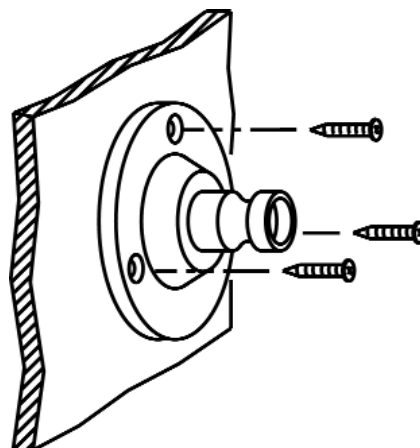
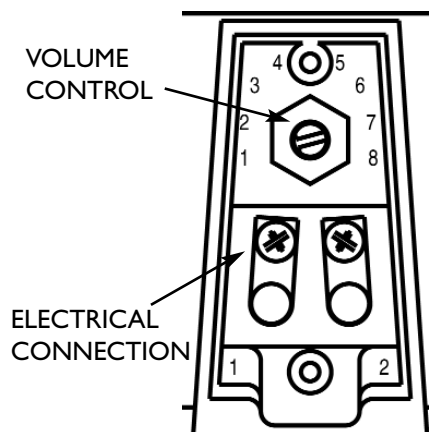

Figure 4



BOGEN
COMMUNICATIONS, INC.

50 Spring Street, Ramsey NJ 07446
Tel. 201-934-8500, Fax: 201-934-9832
www.bogen.com