



TECHNICAL Practice

TELECOM SOLUTIONS FOR THE 21ST CENTURY

BLK-1A

**Line Status
Strobe Light Kit**

December 26, 2001

Provide Strobe Light Indication of Line Status



The **BLK-1A** provides high visibility indication of analog line status through a high powered one million candle power strobe light. The **BLK-1A** is the ideal solution for the hearing impaired and can be used equally well in loud warehouses or factories, where ringing phones can not be heard. Alternatively, the **BLK-1A** can be used to add emergency notification to pre-existing emergency phones by turning on the strobe light when the emergency phone is in use.

The kit includes: (1) control module, (1) blue strobe light, (1) 12V DC power adapter, (1) single gang weatherproof mounting box with gaskets and hardware, (2) wire nuts, and 20 feet of wire.

The control module can be installed on any standard telephone line or analog PABX/KSU station. The 1 million candle power strobe can be interfaced to flash on ringing or a combination of ringing and off-hook (line in-use).

The **LDB-2** ring/loop detect control module is also available separately.

? Need More Information on the LDB-2?
Call (715) 386-4345 and select 408.

Features

- Vandal resistant polycarbonate lens
- Strobe and control module may be installed separately
- Long life 1 million candle power blue strobe light
- **Flush mount or surface mount with weather proof single gang box (included)**
- **3/4" knockouts for connecting conduit, etc.**
- Easy terminal screw installation
- Can be configured to signal ringing or a combination of both ringing and off-hook (line in-use)
- Auxiliary relay contact output provided

Phone... 715.386.8861

info@vikingelectronics.com

http://www.vikingelectronics.com

Applications

- Ringing Phone or TTY indication for the hearing impaired
- Ringing phone indication in loud warehouses and factories
- Emergency illumination for emergency phones in elevators, campuses, hallways, parking ramps, etc.
- Alarm indication for security systems or alarm panels with phone dialers

Specifications

Power: 120V AC to 12V DC adapter provided
Strobe Dimensions: 111mm diameter x 69mm (4.38" x 2.75")
Control Module Dimensions: 74mm x 53mm x 25mm (2.9" x 2.1" x 1.0")
Shipping Weight: 1.5 kg (3.3 lbs)
Operating Temperature: -26° to 54°C (-15° to 130° F)
Contact Rating: .5A @ 125V AC/1A @ 30V DC
Minimum Loop Current: 15 mA
Minimum Ring Voltage: 40 V RMS
Strobe Output: 1 million candle power @ 1 second flash rate
Ringer Equivalence: 0.5 A REN
Connections: 10 pin screw terminal block and (2) wire nuts
Control Module Mounting: (2) screws (not included) or foam tape (included)
Strobe Mounting: Fasten to wall, post, etc. with complete surface mounting hardware included

Installation

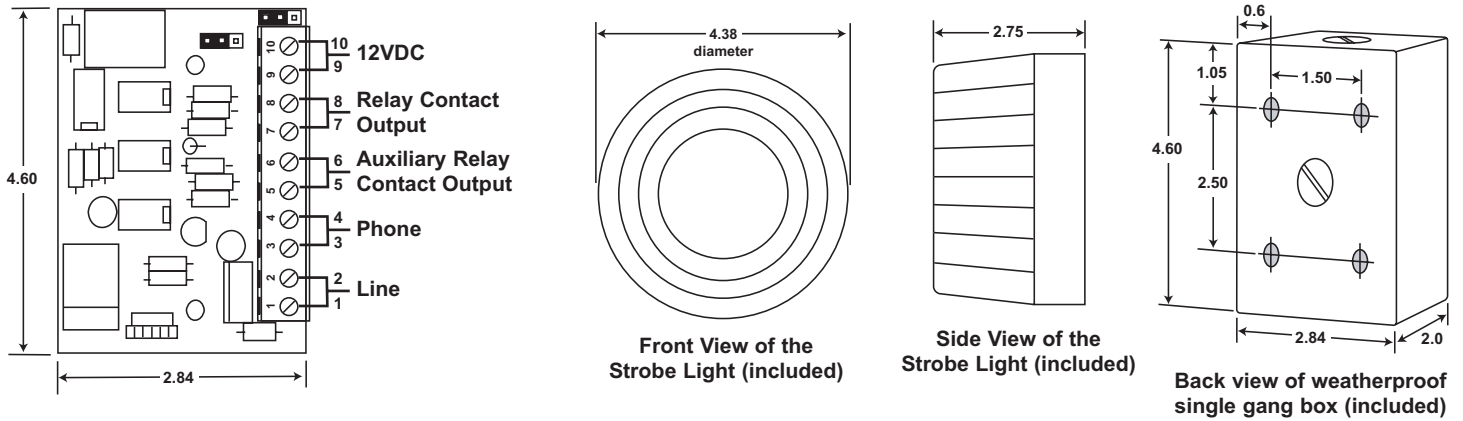

! **IMPORTANT:** Electronic devices are susceptible to lightning and power station electrical surges from both the AC outlet and the telephone line. It is recommended that a surge protector be installed to protect against such surges. Contact Panamax at (800) 472-5555 or Electronic Specialists Inc. at (800) 225-4876.

A. Installing the Strobe Light

1. Using the Included Weatherproof Box

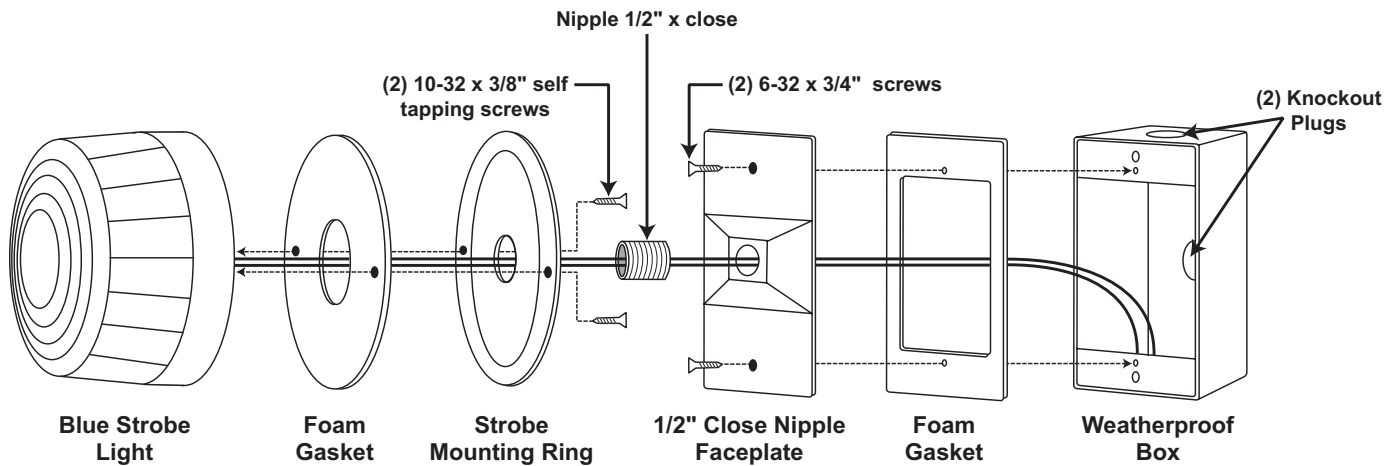

2. Front Mounting Without the Weatherproof Box

The BLK-1A Strobe Light Kit may be mounted without using the included weatherproof box. To mount the strobe light from the front, use the diagram below.

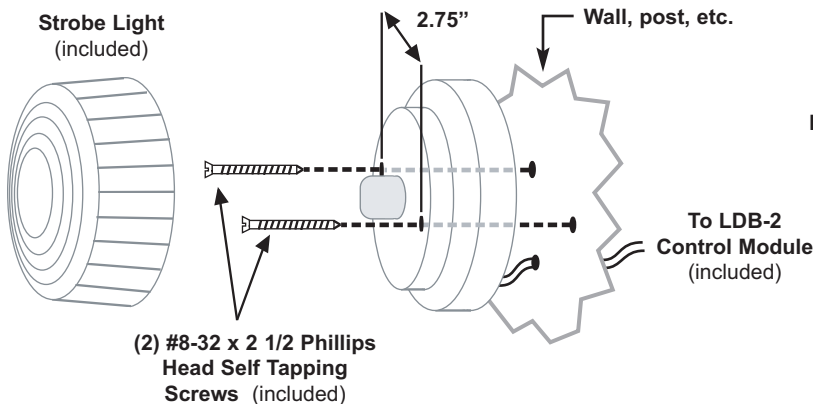

3. Rear Mounting Without the Weatherproof Box

To mount the strobe light from the rear, use the diagram below.

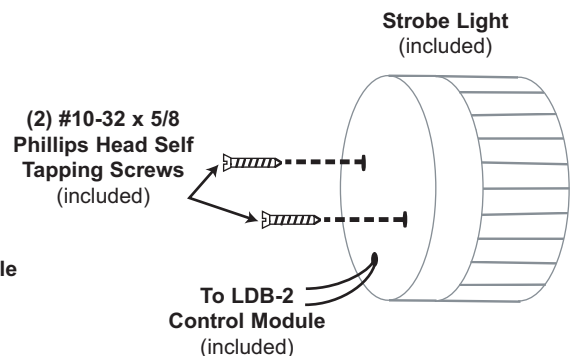

B. Mounting the LDB-2 Control Module

The control module is designed to be wall mounted using either screws or the included foam tape.

Step 1.	Remove the cover from the control module.
Step 2.	Mount the unit on a wall, using either screws or the included foam tape. Make sure there is easy access to the internal terminal block. The internal board of the control module can be rotated exposing the two mounting holes in the chassis.
Step 3.	Once mounted, swing the board back into position and attach wires.
Step 4.	Replace cover making sure wires protrude through rectangular wire pass-through.

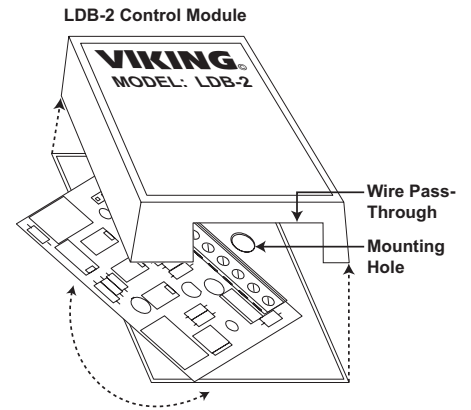

Note: For information on installing the **BLK-1A** with the **E-1600-20A** see **Other Applications**.

C. Configuring the BLK-1A for Ring Indication Only

Turns on the strobe light and provides an auxiliary contact closure during ringing only.

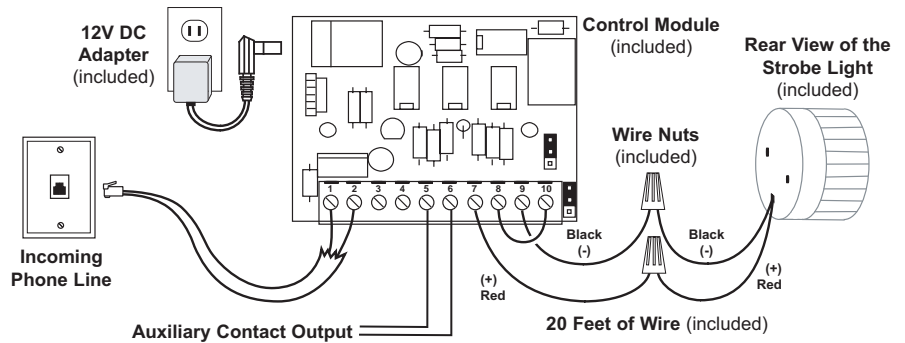

D. Configuring the BLK-1A for Both Ring and Loop Indication

Turns on the strobe light and provides an auxiliary contact closure during ringing and when the phone is in use.

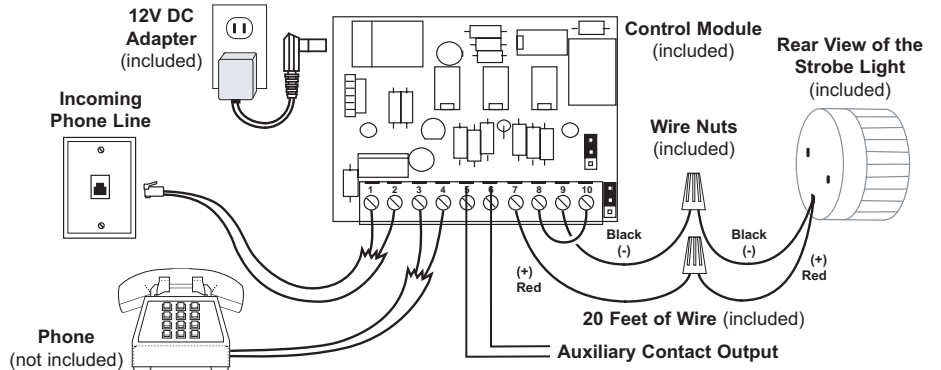

Programming

A. Adjustable Relay Closure Time Out

The time out POT (see diagram to the right) can be adjusted from 2 to 6 seconds. Turn the time out POT counter clockwise to decrease the closure time. Turn it clockwise to increase the closure time. When monitoring for ring, turning the time out POT fully clockwise will allow the relay closure to be maintained (strobe will continue flashing) during the entire off time of the ring signal. When monitoring for loop, the relay closure will be maintained while off-hook and will time out following an on-hook (strobe will continue to flash until time-out occurs).

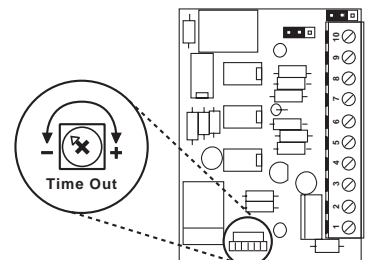

B. Relay Contact Selections

The auxiliary relay contact located at terminal pins 5 & 6 can be used to control other equipment. It can be set for normally open (N/O) or normally closed (N/C) by repositioning **JP1** (see diagram to the right). **Note:** **JP2** should be left in the normally open position (N/O) for controlling the strobe light.

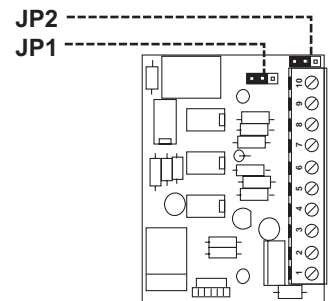

<input type="checkbox"/> <input type="checkbox"/>	Auxiliary relay contact set to normally open (N/O).
<input type="checkbox"/> <input checked="" type="checkbox"/>	Auxiliary relay contact set to normally closed (N/C).

Operation

A. Ring Indication

When the **LDB-2** detects an incoming ring signal, it activates a relay opening or closing the contacts across terminals 5 & 6 and 7 & 8 (depending on placement of **JP1** and **JP2**). When wired as shown in **Installation** section **C**, and the time-out POT is in the maximum position, the blue strobe light will flash during the entire ring cadence (on and off cycles) and will stop flashing approximately 6 seconds after ringing has stopped.

B. Off-Hook Indication

When the **LDB-2** detects an off-hook condition (loop current) on terminals 3 & 4, it activates a relay opening or closing the contacts across terminals 5 & 6 and 7 & 8 (depending on placement of **JP1** and **JP2**). When wired as shown in **Installation** section **D**, and the time-out POT is set to minimum, the blue strobe light will flash during the entire off-hook condition and will stop flashing approximately 2 seconds after the phone on terminals 3 & 4 has gone back on hook.

Other Applications

A. Mounting the LDB-2 with the E-1600-20A

The **BLK-1A** Strobe Kit can be used in conjunction with the **E-1600-20A** Two-Button Phone as shown to the far right, however, special installation and mounting is required. Please follow the steps below when using the **BLK-1A** in conjunction with a surface-mounted **E-1600-20A**.

Step 1.	Drill or use a knockout punch to provide a .875" diameter hole in top of the VE-5x5 .
Step 2.	Make all conduit connections.
Step 3.	Remove the LDB-2 circuit board from chassis.
Step 4.	Make all wire connections to the LDB-2 circuit board.
Step 5.	Using the double-backed tape provided, adhere the LDB-2 circuit board (no chassis) to the inside right hand wall of the VE-5x5 with the power connector closest to the back wall as shown right.
Step 6.	Install the E-1600-20A as explained in its Technical Practice.

? Need More Information on the E-1600-20A? Call (715) 386-4345 and select 215.

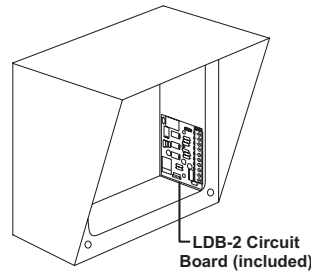

Front View of Optional VE-5x5 (not included)

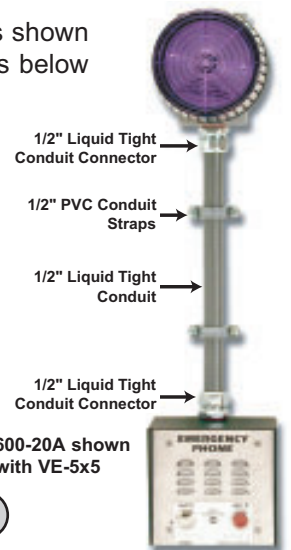

E-1600-20A shown with VE-5x5

? Need More Information on the VE-5x5? Call (715) 386-4345 and select 424.

B. Controlling (4) Separate Strobe Lights

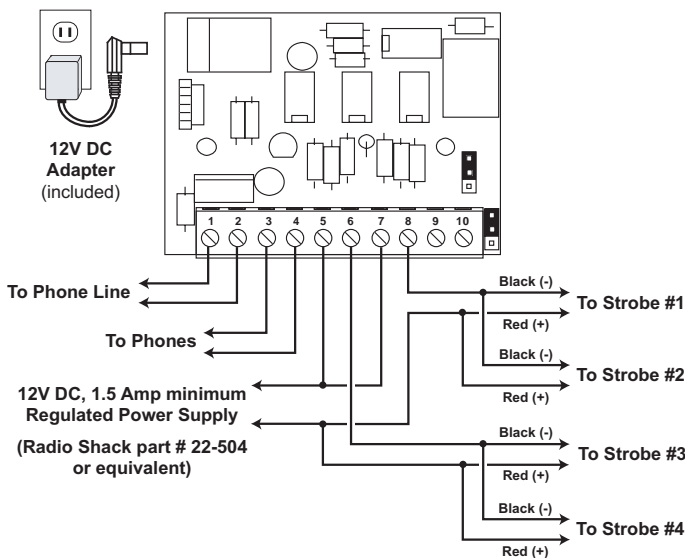

C. Operating a BLK-1A with a Contact Closure

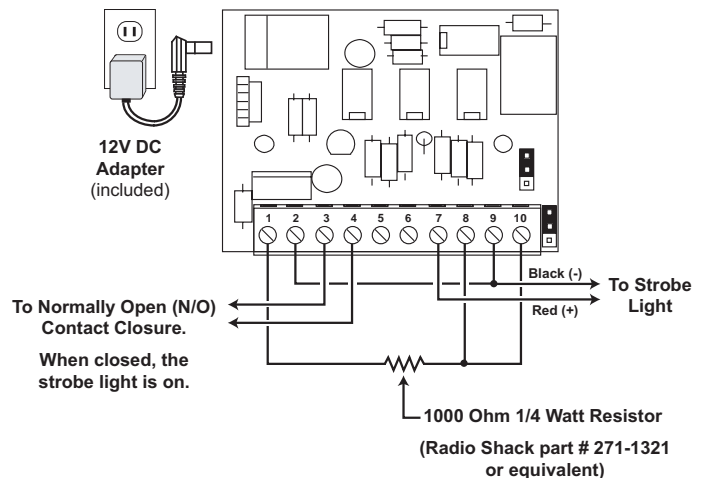

Product Support Line...715.386.8666

Fax Back Line...715.386.4345

Due to the dynamic nature of the product design, the information contained in this document is subject to change without notice. Viking Electronics, and its affiliates and/or subsidiaries assume no responsibility for errors and omissions contained in this information. Revisions of this document or new editions of it may be issued to incorporate such changes.